

TECHNOLOGIEVORSPRUNG IST HORN

HORN - LEADERS IN GROOVING TECHNOLOGY



NEU
NEW

Nutstoßen auf CNC-Maschinen mit S117 ab Ø 14 mm

Zur Direktaufnahme in der Maschine und für angetriebene
Nutstoßgeräte der Firmen Benz, EWS und Schwarzer



Broaching on CNC machines with inserts S117 from Ø 14 mm

For direct mounting in the machine as well as mounting in a live
broaching attachment from the companies Benz, EWS and Schwarzer

- **EINSTECHEN**
 - GROOVING
- **ABSTECHEN**
 - PARTING OFF
- **NUTFRÄSEN**
 - GROOVE MILLING
- **NUTSTOSSEN**
 - BROACHING
- **KOPIERFRÄSEN**
 - PROFILE MILLING
- **BOHREN**
 - DRILLING
- **REIBEN**
 - REAMING



Hartmetall-Werkzeugfabrik
Paul Horn GmbH
Unter dem Holz 33-35
72072 Tübingen
Tel.: +49 (0)7071 / 7004-0
Fax: +49 (0)7071 / 7 28 93
info@phorn.de
www.phorn.de



KLEMMHALTER Typ

TOOLHOLDER Type

SH117

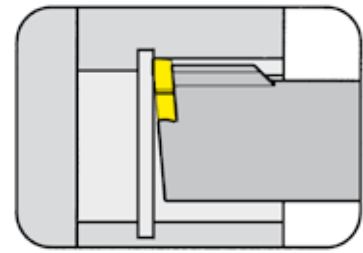

Bohrungs-Ø ab Bore Ø from 14,0 mm

für Schneidplatte
for use with Insert

Typ S117
Type

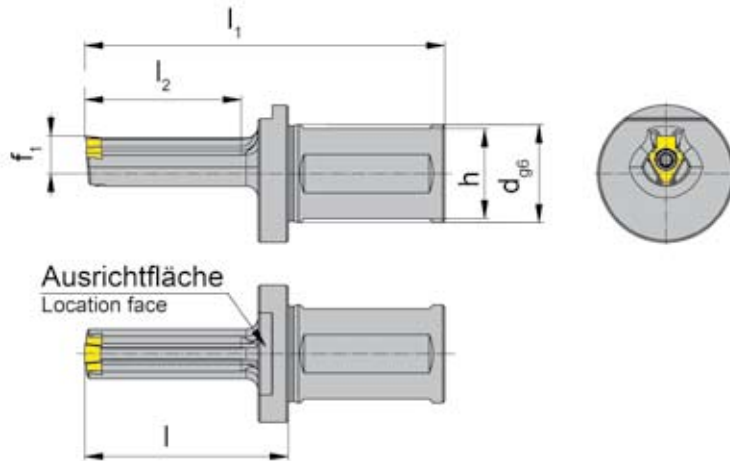

Bestellnummer Part number	d	h	l	l ₁	l ₂	D _{min}	f ₁	Form Form
SH117.1425.1.3.08	25	23	32	72	20	14	9,6	G
SH117.1425.1.08	25	23	42	82	30	14	9,6	F
SH117.1425.2.08	25	23	52	92	40	14	9,6	F

Weitere Abmessungen auf Anfrage
Further sizes upon request

Abmessungen in mm
Dimensions in mm

Ersatzteile

Spare parts

Klemmhalter Toolholder	Spannschraube Screw	TORX PLUS®-Schlüssel TORX PLUS® Wrench
SH117.1425....	030.3509.T15P	T15PQ

NUTSTOSSEN

BROACHING



KLEMMHALTER Typ

TOOLHOLDER Type

SHM117

mit innerer Kühlmittelzufuhr
with through coolant supply

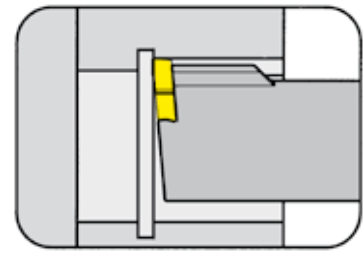

Bohrungs-Ø ab	Bore Ø from	14,0 mm
---------------	-------------	---------

Schaftmaterial: Hartmetall (schwingungsarm)
Material of shank: Carbide - Giving a good vibration resistance

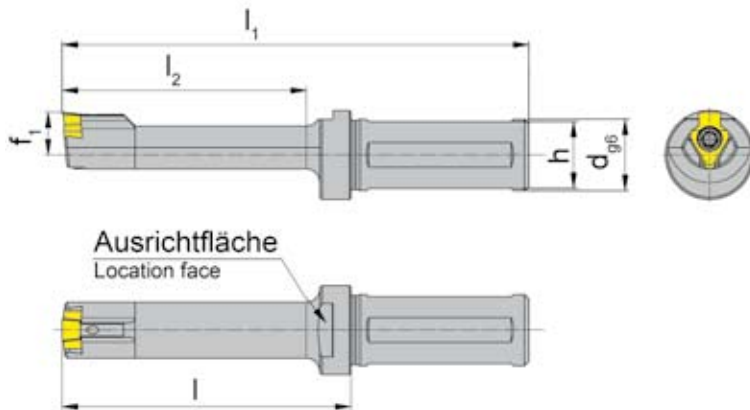

für Schneidplatte
for use with Insert

Typ S117
Type

mit innerer Kühlmittelzufuhr
with through coolant supply

Bestellnummer Part number	d	h	l	l ₁	l ₂	D _{min}	f ₁	Form Form
SHM117.1425.3.08	25	23	65	105	55	14	9,6	F

Weitere Abmessungen auf Anfrage
Further sizes upon request

Abmessungen in mm
Dimensions in mm

Ersatzteile

Spare parts

Klemmhalter Toolholder	Spannschraube Screw	TORX PLUS®-Schlüssel TORX PLUS® Wrench
SHM117.1425.3.08	030.3509.T15P	T15PQ

KLEMMHALTER Typ

TOOLHOLDER Type

SH117

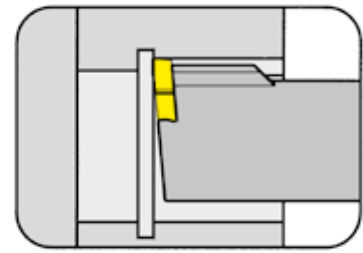

Bohrungs-Ø ab Bore Ø from 14,0 mm

nur für Nutstoßgeräte EWS-Slot und BENZ LinA
only usable for broaching devices EWS-Slot and BENZ LinA

für Schneidplatte
for use with Insert

Typ S117
Type

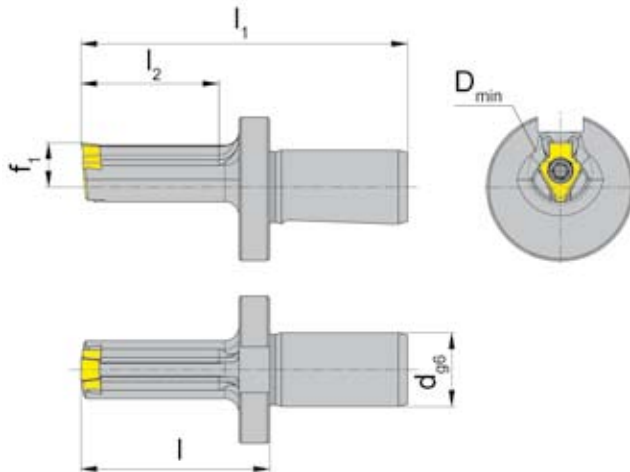

Bestellnummer Part number	d	l	l ₁	l ₂	D _{min}	f ₁	Form Form
SH117.1416.E1.08	16	41	71	30	14	9,6	F

Ausführungen für weitere Geräteschnittstellen auf Anfrage
Further sizes for other device interfaces upon request

Abmessungen in mm
Dimensions in mm

Ersatzteile

Spare parts

Klemmhalter Toolholder	Spannschraube Screw	TORX PLUS®-Schlüssel TORX PLUS® Wrench
SH117.1416.E1.08	030.3509.T15P	T15PQ

KLEMMHALTER Typ

TOOLHOLDER Type

SH117

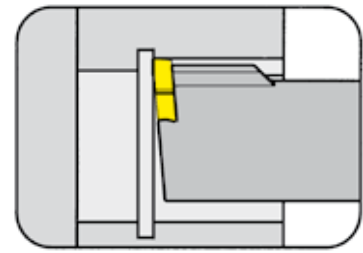

Bohrungs-Ø ab Bore Ø from 14,0 mm

für Nutstoßgerät Firma Schwarzer
for broaching device Schwarzer

für Schneidplatte
for use with Insert

Typ S117
Type

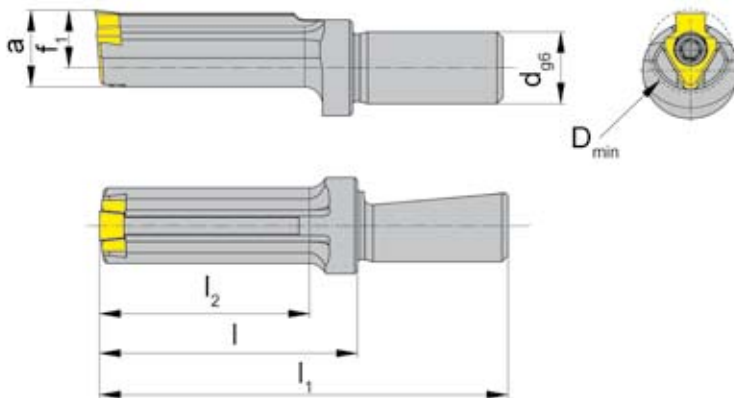

Bestellnummer Part number	d	l	l ₁	l ₂	D _{min}	f ₁	a	Form Form
SH117.1412.S1.08	12	33	58	25	14	9,6	12,8	F
SH117.1412.S2.08		43	68	35				

Ausführungen für weitere Geräteschnittstellen auf Anfrage
Further sizes for other device interfaces upon request

Abmessungen in mm
Dimensions in mm

Ersatzteile

Spare parts

Klemmhalter Toolholder	Spannschraube Screw	TORX PLUS®-Schlüssel TORX PLUS® Wrench
SH117.1412.S...	030.3509.T15P	T15PQ

NUTSTOSSEN

BROACHING



KLEMMHALTER Typ

TOOLHOLDER Type

SH117

mit innerer Kühlmittelzufuhr
with through coolant supply

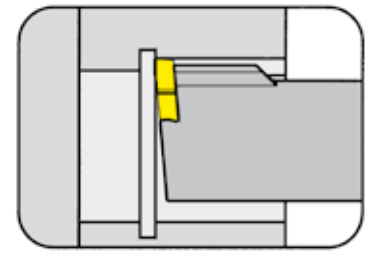

Bohrungs-Ø ab Bore Ø from 14,0 mm

für Nutstoßgerät Firma Schwarzer "2in1"
for broaching device Schwarzer "2in1"

für Schneidplatte
for use with Insert

Typ S117
Type

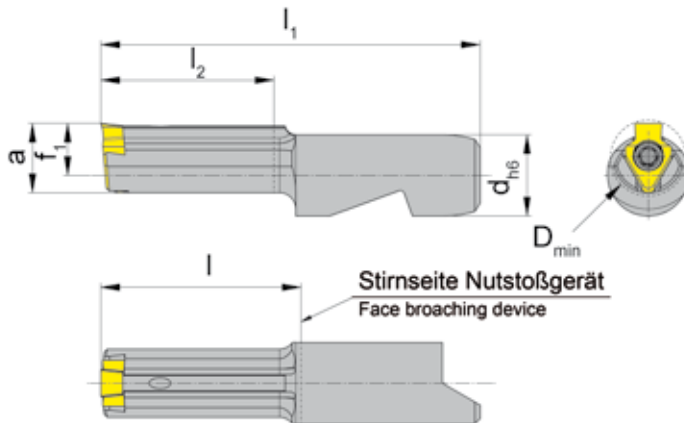

Bestellnummer Part number	d	l	l ₁	l ₂	D _{min}	f ₁	a	Form Form
SH117.0932.S.08	15	37	70	32	14	9,6	12,8	F

Ausführungen für weitere Geräteschnittstellen auf Anfrage
Further sizes for other device interfaces upon request

Abmessungen in mm
Dimensions in mm

Ersatzteile

Spare parts

Klemmhalter Toolholder	Spannschraube Screw	TORX PLUS®-Schlüssel TORX PLUS® Wrench
SH117.0932.S.08	030.3509.T15P	T15PQ

NUTSTOSSEN BROACHING



SCHNEIDPLATTE Typ

INSERT Type

S117

Toleranzklasse P9
Tolerance grade P9

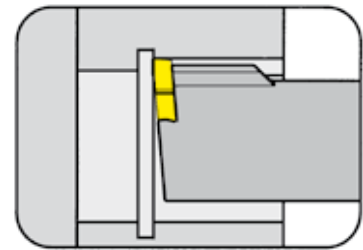

Bohrungs-Ø ab	Bore Ø from	14,0 mm
Nuttiefe bis	Depth of groove up to	2,7 mm

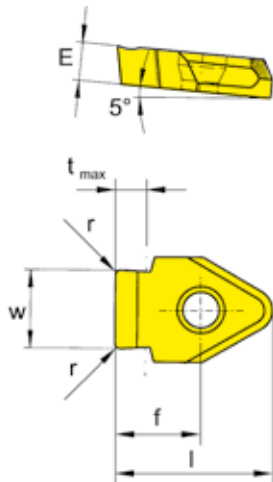

für Klemmhalter
for use with Toolholder

Typ SH117
Type SHM117

Längsnuten nach
DIN6885
Keyways according to DIN6885

Bestellnummer Part number	Nw	w	r	E	l	t _{max}	D _{min}	f	Form Form	HM-Sorten / Carbide grades			
										MG12	TA45	TN35	TI25
S117.0298.01.08	3	2,99	0,12	4	13	2,0	14	6	G		▲		
S117.0397.01.08	4	3,98	0,12	4	13	2,1	14	6	F		▲		
S117.0497.02.08	5	4,98	0,20	4	13	2,7	14	6	F		▲		
										P	•		
										M	•		
										K	•		
										S	•		
										N	•		
										H			

- ▲ ab Lager / on stock Δ 4 Wochen / 4 weeks
- Haupteinsatzbereich / main recommendation
- o bedingt einsetzbar / alternative recommendation
- unbeschichtete HM-Sorten / uncoated grades
- beschichtete HM-Sorten / coated grades
- bestückt/Cermet / brazed/Cermet

Abmessungen in mm
Dimensions in mm

Hinweis:
Die Form der Schneidplatte muss der Halterform entsprechen.
Bsp.: Klemmhalter Form A = Schneidplatte Form A

Note:
The insert form must correspond to the holder form.
E.g.: Form A Toolholder = Form A Insert

HM-Sorten
Carbide grades

NUTSTOSSEN

BROACHING



SCHNEIDPLATTE Typ

INSERT Type

S117

Toleranzklasse JS9
Tolerance grade JS9

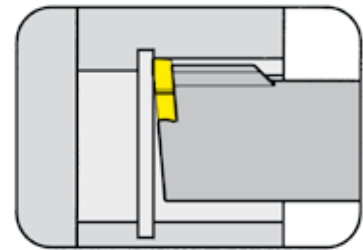

Bohrungs-Ø ab	Bore Ø from	14,0 mm
Nuttiefe bis	Depth of groove up to	2,7 mm

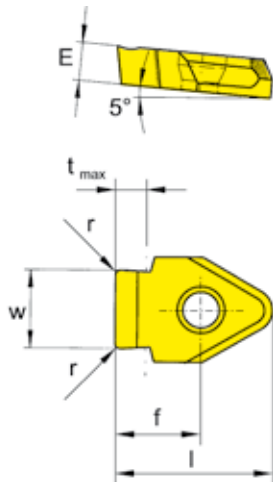

für Klemmhalter
for use with Toolholder

Typ SH117
Type SHM117

Längsnuten nach
DIN6885
Keyways according to DIN6885

Bestellnummer Part number	Nw	w	r	E	l	t _{max}	D _{min}	f	Form Form	HM-Sorten / Carbide grades			
										MG12	TA45	TN35	TI25
S117.0300.01.08	3	3,01	0,12	4	13	2,0	14	6	G		▲		
S117.0400.01.08	4	4,01	0,12	4	13	2,1	14	6	F		▲		
S117.0500.02.08	5	5,01	0,20	4	13	2,7	14	6	F		▲		
										P	•		
										M	•		
										K	•		
										S	•		
										N	•		
										H			

- ▲ ab Lager / on stock Δ 4 Wochen / 4 weeks
- Haupteinsatzbereich / main recommendation
- o bedingt einsetzbar / alternative recommendation
- unbeschichtete HM-Sorten / uncoated grades
- beschichtete HM-Sorten / coated grades
- bestückt/Cermet / brazed/Cermet

Abmessungen in mm
Dimensions in mm

Hinweis:

Note:
Die Form der Schneidplatte muss der Halterform entsprechen.
Bsp.: Klemmhalter Form A = Schneidplatte Form A
The insert form must correspond to the holder form.
E.g.: Form A Toolholder = Form A Insert

HM-Sorten
Carbide grades

NUTSTOSSEN

BROACHING



SCHNEIDPLATTE Typ

INSERT Type

S117

Toleranzklasse C11

Tolerance grade C11

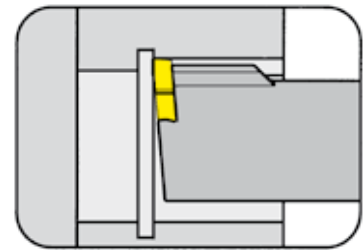

Bohrungs-Ø ab	Bore Ø from	14,0 mm
Nuttiefe bis	Depth of groove up to	2,1 mm

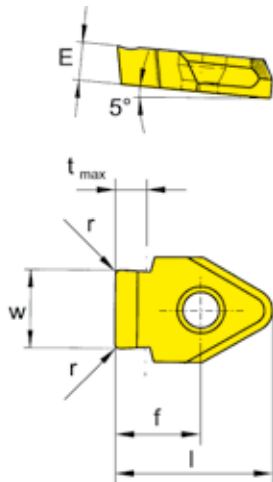

für Klemmhalter
for use with Toolholder

Typ SH117
Type SHM117

Längsnuten nach DIN138
Keyways according to DIN138

Bestellnummer Part number	Nw	w	r	E	l	t _{max}	D _{min}	f	Form Form	MG12	TA45	TN35	TI25
S117.0310.04.08	3	3,10	0,35	4	13	2,0	14	6	G		▲		
S117.0410.05.08	4	4,12	0,50	4	13	2,1	14	6	F		▲		
										P	•		
										M	•		
										K	•		
										S	•		
										N	•		
										H			

- ▲ ab Lager / on stock Δ 4 Wochen / 4 weeks
- Haupteinsatzbereich / main recommendation
- o bedingt einsetzbar / alternative recommendation
- unbeschichtete HM-Sorten / uncoated grades
- beschichtete HM-Sorten / coated grades
- bestückt/Cermet / brazed/Cermet

Abmessungen in mm
Dimensions in mm

Hinweis:

Die Form der Schneidplatte muss der Halterform entsprechen.
Bsp.: Klemmhalter Form A = Schneidplatte Form A

Note:

The insert form must correspond to the holder form.
E.g.: Form A Toolholder = Form A Insert

HM-Sorten
Carbide grades

NUTSTOSSEN-FASEN

BROACHING-CHAMFERING



SCHNEIDPLATTE Typ
INSERT Type

S117

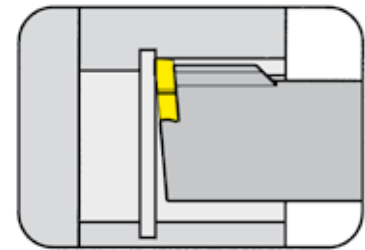

Bohrungs-Ø ab Bore Ø from 14,0 mm

für Klemmhalter
for use with Toolholder

Typ SH117
Type SHM117

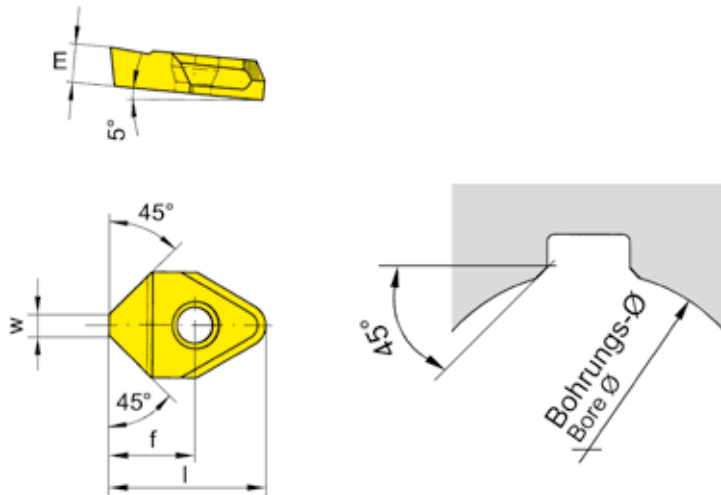

Fasen
Chamfering

Bestellnummer Part number	w	l	D _{min}	f	Form Form	MG12	TA45	TN35	TI25
S117.2445.08	2,4	13	14	6	F		▲		
▲ ab Lager / on stock Δ 4 Wochen / 4 weeks						P	•		
● Haupteinsatzbereich / main recommendation						M	•		
o bedingt einsetzbar / alternative recommendation						K	•		
■ unbeschichtete HM-Sorten / uncoated grades						S	•		
■ beschichtete HM-Sorten / coated grades						N	•		
■ bestückt/Cermet / brazed/Cermet						H			

Abmessungen in mm
Dimensions in mm

HM-Sorten
Carbide grades

Hinweis:

Die Form der Schneidplatte muss der Halterform entsprechen.
Bsp.: Klemmhalter Form A = Schneidplatte Form A

Note:

The insert form must correspond to the holder form.
E.g.: Form A Toolholder = Form A Insert



TECHNOLOGIEVORSPRUNG IST HORN
HORN - LEADERS IN GROOVING TECHNOLOGY

www.phorn.de

■ EINSTECHEN

■ GROOVING

■ ABSTECHEN

■ PARTING OFF

■ NUTFRÄSEN

■ GROOVE MILLING

■ NUTSTOSSEN

■ BROACHING

■ KOPIERFRÄSEN

■ PROFILE MILLING

■ BOHREN

■ DRILLING

■ REIBEN

■ REAMING



HARTMETALL WERKZEUGFABRIK

PAUL HORN GmbH

Unter dem Holz 33-35 Tel.: +49 (0)7071-7004 0
D-72072 Tübingen Fax: +49 (0)7071-7 28 93

E-Mail: info@phorn.de
www.phorn.de

HORN CUTTING TOOLS Ltd.

32 New Street Tel.: +44 (0)1 425 481 800
Ringwood Fax: +44 (0)1 425 481 888
Hampshire
BH24 3AD

E-Mail: info@phorn.co.uk
www.phorn.co.uk

HORN S.A.S

665, av. Blaise Pascal Tel.: +33 (0)1 64 88 5958
Zone Industrielle Fax: +33 (0)1 64 88 6049
77127 Lieusaint

E-Mail: infos@horn.fr
www.horn.fr

HORN USA, Inc.

320 Premier Court Tel.: +1 (888)818-HORN
Suite 205 Fax: +1 (615)771-4101
Franklin, TN 37067

E-Mail: sales@hornusa.com
www.hornusa.com

HORN Magyarország Kft.

H-9027 Győr Tel.: +36 96 55 05 31
Gesztenyefa u. 4. Fax: +36 96 55 05 32

E-Mail: technik@phorn.hu
www.phorn.hu

INFO13.11DE

11/2011

Printed in Germany