



NEW
MultiDRILL Micro &
8xD SteelDrill



EMUGE
SOLID CARBIDE DRILLS

Solid Carbide Drill Program

EMUGE-FRANKEN recognizes that one style of tool does not fit all industries, operations and applications, so we have developed new drill designs with more choices, grouped into three performance classes to ideally fit your needs.

★ **MultiDRILL** — affordable, top quality carbide drills for high mix/low volume operations and a wide range of materials. MultiDRILL provides longer tool life and productivity — an ideal high-penetration rate drill for everyday use. A line of **NC Spot Drills** are also available for tight hole locations.

★★ **SteelDrill and InoxDrill, in addition to EF-Drill**, are higher performance tools with specialized geometries for specific material groups or applications where cycle time is critical. **EF-C Step Drills** are another example — high performance carbide drills available from stock in various step lengths for pre-drilling tapped holes with chamfers in one operation. EMUGE **Micro Drills** also produce high-performance results in demanding materials at high feed rates.

★★★★ **PunchDrill** — another EMUGE-FRANKEN innovation that dramatically reduces cycle time in high volume production, the result of continuous efforts to develop cutting edge designs and technologies that push the boundaries of machining.

The EMUGE Difference:

- **Unique Carbide Grades** developed specifically for drilling applications
- **PVD Applied Cutting Tool Coatings** tailored to increase tool performance and tool life
- **Cutting Edge Honing** applied with state-of-the-art technology for consistent results
- **Flute Forms and Point Geometries** adjusted to fit the application. Extensive research and testing, yields unique, high efficiency designs

All tools manufactured to exceed the highest quality standards in the industry, assuring maximum, reliable performance.



Performance Classes of EMUGE Drills

The performance classifications indicated by stars make it easier to find the right tool for the specific performance and application requirements.

- ★ **General Performance**
 Drills for standard requirements and versatile use
- ★★ **High Performance**
 Drills for more demanding materials or applications
- ★★★ **Innovative Design / Performance**
 Unique tool technology for unprecedented speed/performance

	Table of Contents	Pages		
		EMUGE Drill Program		
		Product Finder	4 - 5	
★	NC Spot Drills	Product Pages Cutting Data	6-9 57	
	MultiDRILL 3 x D	Product Pages Cutting Data	10-14 52-53	
	MultiDRILL 5 x D	Product Pages Cutting Data	15-17 52-53	
	MultiDRILL 8 x D	Product Pages Cutting Data	18-20 52-53	
	MultiDRILL 6 x D Micro	Product Pages Cutting Data	21 61	 NEW
★★	SteelDrill 3 x D	Product Pages Cutting Data	22-26 54-55	
	SteelDrill 5 x D	Product Pages Cutting Data	27-29 54-55	
	SteelDrill 8 x D	Product Pages Cutting Data	30-33 54-55	 NEW
	EF-Drill 12 x D	Product Pages Cutting Data	34-37 56	
	InoxDrill 3 x D	Product Pages Cutting Data	38-42 58-59	
	InoxDrill 5 x D	Product Pages Cutting Data	43-45 58-59	
	Micro Drills 6 x D	Product Pages Cutting Data	46-47 60-61	
	EF-C Step Drill	Product Pages Cutting Data	48-49 52-53	
★★★	PunchDrill	PunchDrill Overview	50-51	
		Cutting Data	52-61	
		Technical Information	62-67	
		Reconditioning Services	Back Cover	

Product Finder / Range of Applications

Please note:

Suitability of drills are marked in the respective columns as follows:

- = very suitable
- = suitable

Appropriate cutting speeds v_c [SFM] and feed per revolution values f [in/rev.] are on pages 52-61

Applications – Materials		Hardness Range			Material Examples	Coolant-lubricant recommendation			
		HRC	BHN	N/mm ²		Emulsion	Oil	Minimum quantity lubrication (MQL)	Dry / Pressurized air
P	Steel materials								
	1.1 Cold-extrusion steels, Construction steels, Free-cutting steels, etc.		≤ 180	≤ 600	1010 / 1018 / 1020 / 12L14 / 12L15 / A36 / T1	■	■	□	
	2.1 Construction steels, Cementation steels, Steel castings, etc.	≤ 22	≤ 235	≤ 800	A36 / T1 / 1030-1095 / 4140 / 4340 / 8620	■	■	□	
	3.1 Cementation steels, Heat-treatable steels, Cold work steels, etc.	≤ 31	≤ 295	≤ 1000	4140 / 4340 / 8620 / P20 / H13 / D2 / A2 / S7 / H1150	■	■	□	
	4.1 Heat-treatable steels, Cold work steels, Nitriding steels, etc.	≤ 38	≤ 355	≤ 1200	4140 / 4340 / 8620 / P20 / H13 / D2 / 300M / 52100 / M1-M42	■	■	□	
5.1 High-alloyed steels, Cold work steels, Hot work steels, etc.	≤ 44	≤ 415	≤ 1400	4140 / 4340 / 8620 / P20 / H13 / D2 / 300M / 52100	■	■	□		
M	Stainless steel materials								
	1.1 Ferritic, martensitic	≤ 29	≤ 280	≤ 950	410 / 440 / 440C / 17-4 PH	■	■		
	2.1 Austenitic	≤ 29	≤ 280	≤ 950	303 / 304 / 316 / 316L / 321	■	■		
	3.1 Austenitic-ferritic (Duplex)	≤ 35	≤ 325	≤ 1100		■	■		
4.1 Austenitic-ferritic heat-resistant (Super Duplex)	≤ 39	≤ 370	≤ 1250		■	■			
K	Cast materials								
	1.1 Cast iron with lamellar graphite (GJL)		30 - 75	100 - 250	Grey cast irons G10-GG40	■		□	□
	1.2		75 - 135	250 - 450		■		□	□
	2.1 Cast iron with nodular graphite (GJS)		105 - 150	350 - 500	Nodular GGG40-GGG70	■		□	□
	2.2		150 - 265	500 - 900		■		□	□
	3.1 Cast iron with vermicular graphite (GJV)		90 - 120	300 - 400	Compact graphite iron (CGI)	■		□	□
3.2		120 - 150	400 - 500		■		□	□	
4.1 Malleable cast iron (GTMW, GTMB)		70 - 145	250 - 500		■		□	□	
4.2		150 - 235	500 - 800	White iron	■		□	□	
N	Non-ferrous materials								
	Aluminum alloys								
	1.1		≤ 60	≤ 200	7075	■	■		
	1.2 Aluminum wrought alloys		≤ 105	≤ 350	6061-T6 / 2024-T4	■	■		
	1.3		≤ 165	≤ 550		■	■		
	1.4 Aluminum cast alloys Si ≤ 7%					■	■		
	1.5 Aluminum cast alloys 7% < Si ≤ 12%					■	■		
	1.6 Aluminum cast alloys 12% < Si ≤ 17%					■	■		
	Copper alloys								
	2.1 Pure copper, low-alloyed copper		≤ 120	≤ 400		■	■		
	2.2 Copper-zinc alloys (brass, long-chipping)		≤ 165	≤ 550		■	■		
	2.3 Copper-zinc alloys (brass, short-chipping)		≤ 165	≤ 550		■	■		
	2.4 Copper-aluminum alloys (alu bronze, long-chipping)		≤ 235	≤ 800		■	■		
	2.5 Copper-tin alloys (tin bronze, long-chipping)		≤ 205	≤ 700		■	■		
	2.6 Copper-tin alloys (tin bronze, short-chipping)		≤ 120	≤ 400		■	■		
	2.7 Special copper alloys		≤ 180	≤ 600		■	■		
	2.8	≤ 44	≤ 415	≤ 1400		■	■		
	Magnesium alloys								
	3.1 Magnesium wrought alloys		≤ 150	≤ 500					
	3.2 Magnesium cast alloys		≤ 150	≤ 500					
Synthetics									
4.1 Duroplastics (short-chipping)									
4.2 Thermoplastics (long-chipping)									
4.3 Fiber-reinforced synthetics (fiber content ≤ 30%)									
4.4 Fiber-reinforced synthetics (fiber content > 30%)									
Special materials									
5.1 Graphite								■	
5.2 Tungsten-copper alloys									
5.3 Composite materials									
S	Special materials								
	Titanium alloys								
	1.1 Pure titanium		≤ 135	≤ 450	CP1 / CP2				
	1.2 Titanium alloys	≤ 27	≤ 265	≤ 900	6AL4V	■	■		
	1.3	≤ 39	≤ 370	≤ 1250		■	■		
	Nickel alloys, cobalt alloys and iron alloys								
	2.1 Pure nickel		≤ 180	≤ 600					
	2.2 Nickel-based alloys	≤ 31	≤ 295	≤ 1000	Monel 500, 718 Inconel annealed	■			
	2.3	≤ 49	≤ 475	≤ 1600	718 Inconel	■			
	2.4 Cobalt-based alloys	≤ 31	≤ 295	≤ 1000					
2.5	≤ 49	≤ 475	≤ 1600	Haynes 25					
2.6 Iron-base alloys	≤ 46	≤ 445	≤ 1500	Incoloy 925					
H	Hard materials								
	1.1	44 - 50				■	■	□	□
	1.2	50 - 55				■	■	□	□
	1.3 High strength steels, hardened steels, hard castings	55 - 60							
	1.4	60 - 63							
	1.5	63 - 66							

★						★★★								
NC SPOT DRILL		MultiDRILL	MultiDRILL	MultiDRILL	MultiDRILL MICRO	STEELDRILL	STEELDRILL	STEELDRILL	EF-DRILL	INOXDRILL	INOXDRILL	MICRO DRILL	EF-C STEP DRILL	Type
142°	90° and 120°	3 x D	5 x D	8 x D	6 x D	3 x D	5 x D	8 x D	12 x D	3 x D	5 x D	6 x D	2 x D-3.5 x D	Drill depth
7	8	12-14	15-17	18-20	21	24-26	27-29	30-33	35-36	40-42	43-45	47	49	Page Nos.
■	■	■	■	■	■	■	■	■	■	■		■	■	1.1
■	■	■	■	■	■	■	■	■	■	■		■	■	2.1
■	□	■	■	■	■	■	■	■	■	■		■	■	3.1
■		■	■	■	■	■	■	■	■	■		■	■	4.1
■		■	■	■	■	■	■	■	■	■		■	■	5.1
□	□	■	■	■	■	■	■	■	■	■	■	■	■	1.1
□	□	■	■	■	■	■	■	■	■	■	■	□	■	2.1
□		■	■	■	■	■	■	■	■	■	■	□	■	3.1
		■	■	■	■	■	■	■	■	■	■	□	■	4.1
■	■	■	■	■	■	■	■	■	■	■		□	□	1.1
■	■	■	■	■	■	■	■	■	■	■		□	□	1.2
□	□	■	■	■	■	■	■	■	■	■		□	□	2.1
□	□	■	■	■	■	■	■	■	■	■		□	□	2.2
□	□	■	■	■	■	■	■	■	■	■		□	□	3.1
□	□	■	■	■	■	■	■	■	■	■		□	□	3.2
□	□	■	■	■	■	■	■	■	■	■		□	□	4.1
□	□	■	■	■	■	■	■	■	■	■		□	□	4.2
□	□	■	■	■	■	■	■	■	■	■	■	□	□	1.1
□	□	■	■	■	■	■	■	■	■	■	■	□	□	1.2
□	□	■	■	■	■	■	■	■	■	■	■	□	□	1.3
□	□	■	■	■	■	■	■	■	■	■	■	□	□	1.4
□	□	■	■	■	■	■	■	■	■	■	■	□	□	1.5
□	□	■	■	■	■	■	■	■	■	■	■	□	□	1.6
□	□	■	■	■	■	■	■	■	■	■	■	■	■	2.1
□	□	■	■	■	■	■	■	■	■	■	■	■	■	2.2
□	□	■	■	■	■	■	■	■	■	■	■	■	■	2.3
□	□	■	■	■	■	■	■	■	■	■	■	■	■	2.4
□	□	■	■	■	■	■	■	■	■	■	■	■	■	2.5
□	□	■	■	■	■	■	■	■	■	■	■	■	■	2.6
□	□	■	■	■	■	■	■	■	■	■	■	■	■	2.7
□	□	■	■	■	■	■	■	■	■	■	■	■	■	2.8
□	□													3.1
□	□													3.2
□	□													4.1
□	□													4.2
														4.3
														4.4
□														5.1
														5.2
														5.3
□	□	■	■	■	■	■	■	■	■	■	■	□	■	1.1
		■	■	■	■	■	■	■	■	■	■	□	■	1.2
		■	■	■	■	■	■	■	■	■	■	□	■	1.3
		■	■	■	■	■	■	■	■	■	■	■	■	2.1
□	□	■	■	■	■	■	■	■	■	■	■	■	■	2.2
□	□	■	■	■	■	■	■	■	■	■	■	■	■	2.3
□	□	■	■	■	■	■	■	■	■	■	■	■	■	2.4
□	□	■	■	■	■	■	■	■	■	■	■	■	■	2.5
□	□	■	■	■	■	■	■	■	■	■	■	■	■	2.6
□		■	■	■	■	■	■	■	■	■	■	■	■	1.1
		■	■	■	■	■	■	■	■	■	■	■	□	1.2
		■	■	■	■	■	■	■	■	■	■	■	■	1.3
		■	■	■	■	■	■	■	■	■	■	■	■	1.4
		■	■	■	■	■	■	■	■	■	■	■	■	1.5



NC Spot Drill



EMUGE-FRANKEN offers a full line of NC Spot Drills

for applications that have tight hole location requirements. All drills are made of premium sub-micro grain carbide and are held to exacting EMUGE-FRANKEN standards.

The 142° offering of NC Spot Drills are designed as a pre-drill operation for carbide drills with 135° or 140° point angles. They are also web-thinned to help eliminate chipping at the center point.

Both the 90° and 120° style NC Spot Drills incorporate a unique web-thinning grind that dramatically increases tool life, especially in steel and stainless steel alloys. EMUGE-FRANKEN developed a double angle design which uses a 142° web thin at the very center point. This reduces axial force during the drilling operation, but it is small enough to not affect the finished angle of the spotting feature.

NOTE: NC Spot Drills are not designed to drill beyond the point angle. They do not have margins on the outer diameter so they should not be used to drill complete holes.



142° Spot Drill

- Single angle 142° point design
- Pre-drill for 135° or 140° point carbide drill
- Premium sub-micro grain carbide substrate
- Tightly held point dimension tolerances
- Cylindrical shanks are ground to h6 tolerances
- PVD applied TiAlN-T14 coating for heat and wear resistance

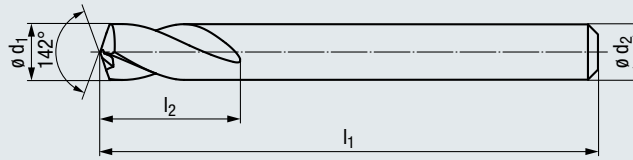

Applications - Materials

P	1.1-5.1
M	1.1-3.1
K	1.1-4.2
N	1.1-1.5, 2.1-4.2, 5.1
S	1.1, 2.2, 2.4, 2.6
H	1.1

Product Finder / Range of Applications and Material Descriptions (see pages 4-5)

Cutting Data (see page 57)

Inch		in		EDP No. HA SHANK
ϕd_1	ϕd_2 h6	l_1	l_2	
1/8	1/8	2.00	0.75	EFUT3300.0317
1/4	1/4	2.50	0.75	EFUT3300.0635
3/8	3/8	3.00	1.00	EFUT3300.0952
1/2	1/2	3.00	1.00	EFUT3300.1270
5/8	5/8	4.00	1.25	EFUT3300.1587
3/4	3/4	4.00	1.75	EFUT3300.1905

Metric		in		EDP No. HA SHANK
ϕd_1	ϕd_2 h6	l_1	l_2	
3	3.00	2.00	0.50	EFUT3300.0300
4	4.00	2.25	0.75	EFUT3300.0400
5	5.00	2.25	0.75	EFUT3300.0500
6	6.00	2.25	0.75	EFUT3300.0600
8	8.00	2.75	1.00	EFUT3300.0800
10	10.00	2.88	1.00	EFUT3300.1000
12	12.00	2.92	1.00	EFUT3300.1200
16	16.00	4.00	1.00	EFUT3300.1600

Calculation of the drilling depth t_z based on the desired spot drilling diameter d_z

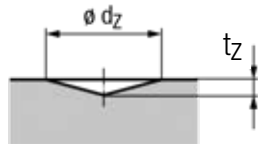

$$t_z = \tan \left(90 - \frac{142}{2} \right) \times \frac{d_z}{2}$$



90° and 120° Spot Drills

- Double tip angle with short chisel edge reduces axial force requirement
- 142° entry point angle creates better chip flow
- Secondary 90° or 120° angle creates desired chamfer
- Unique geometry for significant longer tool life
- Cylindrical shanks are ground to h6 tolerances



90°



120°

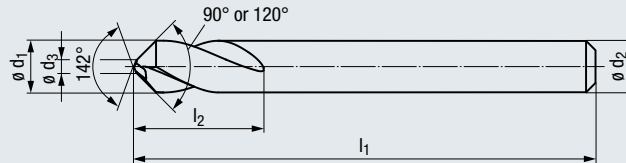

Applications - Materials

P	1.1-3.1
M	1.1-2.1
K	1.1-3.1, 4.1-4.2
N	1.1-5, 2.1-2.6, 3.1-4.2
S	1.1, 2.2

Product Finder / Range of Applications and Material Descriptions (see pages 4-5)

Cutting Data (see page 57)

90° NC SPOT DRILLS

Inch	in				EDP No. HA SHANK	
	ϕd_1	ϕd_3	ϕd_2 h6	l_1		l_2
1/8		0.034	1/8	2.00	0.75	EFUT3100.0317
1/4		0.068	1/4	2.50	0.75	EFUT3100.0635
3/8		0.101	3/8	3.00	1.00	EFUT3100.0952
1/2		0.135	1/2	3.00	1.00	EFUT3100.1270
5/8		0.169	5/8	4.00	1.25	EFUT3100.1587
3/4		0.203	3/4	4.00	1.75	EFUT3100.1905

Metric	mm		in		EDP No. HA SHANK	
	ϕd_1	ϕd_3	ϕd_2 h6	l_1		l_2
3.0		0.81	3.0	2.00	0.50	EFUT3100.0300
4.0		1.08	4.0	2.25	0.75	EFUT3100.0400
5.0		1.35	5.0	2.25	0.75	EFUT3100.0500
6.0		1.62	6.0	2.25	0.75	EFUT3100.0600
8.0		2.16	8.0	2.75	1.00	EFUT3100.0800
10.0		2.70	10.0	2.88	1.00	EFUT3100.1000
12.0		3.25	12.0	2.92	1.00	EFUT3100.1200
16.0		4.33	16.0	4.00	1.00	EFUT3100.1600

120° NC SPOT DRILLS

Inch	in				EDP No. HA SHANK	
	ϕd_1	ϕd_3	ϕd_2 h6	l_1		l_2
1/8		0.029	1/8	2.00	0.75	EFUT3200.0317
1/4		0.059	1/4	2.50	0.75	EFUT3200.0635
3/8		0.089	3/8	3.00	1.00	EFUT3200.0952
1/2		0.118	1/2	3.00	1.00	EFUT3200.1270
5/8		0.148	5/8	4.00	1.25	EFUT3200.1587
3/4		0.177	3/4	4.00	1.75	EFUT3200.1905

Metric	mm		in		EDP No. HA SHANK	
	ϕd_1	ϕd_3	ϕd_2 h6	l_1		l_2
3.0		0.71	3.0	2.00	0.50	EFUT3200.0300
4.0		0.95	4.0	2.25	0.75	EFUT3200.0400
5.0		1.18	5.0	2.25	0.75	EFUT3200.0500
6.0		1.42	6.0	2.25	0.75	EFUT3200.0600
8.0		1.89	8.0	2.75	1.00	EFUT3200.0800
10.0		2.36	10.0	2.88	1.00	EFUT3200.1000
12.0		2.84	12.0	2.92	1.00	EFUT3200.1200
16.0		3.78	16.0	4.00	1.00	EFUT3200.1600



MultiDRILL™



The EMUGE MultiDRILL program offers affordable high quality carbide drills for manufacturers that have limited quantity production runs or operate in a job shop environment with many

materials. MultiDRILL can be used successfully in a wide range of materials, providing longer tool life and productivity — a truly “multi-purpose” high-penetration rate drill for everyday use.



Extensive EMUGE-FRANKEN research and testing has resulted in a completely new drill design that is sure to complement any tool kit:

● **MultiDRILL is made of a unique sub-micro grain carbide** with an ultra-fine grain size. This grade is harder than conventional carbide grades used for drilling, yet it retains the ability to withstand shock and chipping.

● **Advanced TIALN-T63 Coating** on 3 x D, 5 x D and 8 x D lengths uses nano-laying technology to create a multi-layer substrate with a surface hardness that exceeds standard TIALN based coatings and an increased oxidation temperature. This enables top performance at elevated temperatures.

● **Double-Margin Design** helps stabilize the drill within the cut and also allows rounder, more accurate hole location. The drill web construction is also unique to MultiDRILL, and the flute form is wide open to allow for maximum chip evacuation.

Concave Cutting Edges

● for higher chip shearing ability, while a tightly controlled edge preparation process allows for consistent tool life on every drill produced. MultiDRILLS are “one-shot” tools that do not require peck cycles. In fact, drill peck feed rates are highly discouraged.

Self-centering

● does not require pre-spot drilling applications.

● **Coolant-thru capability**



MultiDRILL™

3 x D - Coolant Fed

- Double margin design for rounder and straighter holes
- Advanced flute profile designed to enhance chip evacuation of varying materials
- Radius cutting edge for high shearing action
- Unique TiAlN-T63 coating resists heat and wear
- 140° drill point angle

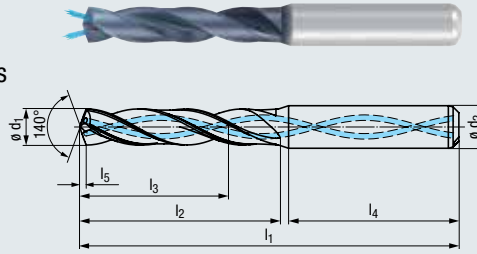

Applications - Materials

P	1.1-5.1
M	1.1-3.1
K	1.1-4.2
N	1.1-1.6, 2.1-2.3
S	1.2-1.3, 2.2-2.3
H	1.1-1.3

Product Finder / Material Descriptions (see pages 4-5)
Cutting Data (see pages 52-53)

Nominal Size Ø d ₁ m7 Tolerance				Taps	Roll Form Taps	mm					EDP No. HA SHANK	
Inch	Fraction	Wire letter	mm			l ₁	l ₂	l ₃	l ₄	l ₅	Ø d ₂ h6 Tol.	
0.1181			3.000	#6-40 UNF		62	20	14	36	0.6	6	TA209744.0300
0.1220			3.100	STI-#4-40		62	20	14	36	0.6	6	TA209744.0310
0.1240			3.150	M3.5x0.35	#6-32 UNC	62	20	14	36	0.7	6	TA209744.0315
0.1250	1/8"		3.175			62	20	14	36	0.7	6	TA209744.0318
0.1260			3.200	BSW 5/32-32	#6-40 UNF	62	20	14	36	0.7	6	TA209744.0320
0.1268			3.220			62	20	14	36	0.7	6	TA209744.0322
0.1280			3.250		M3.5	62	20	14	36	0.7	6	TA209744.0325
0.1299			3.300	M4		62	20	14	36	0.7	6	TA209744.0330
0.1319			3.350			62	20	14	36	0.7	6	TA209744.0335
0.1331			3.380		M3.5x0.35	62	20	14	36	0.7	6	TA209744.0338
0.1339			3.400	MJ4x0.7		62	20	14	36	0.7	6	TA209744.0340
0.1378			3.500	#8-32 UNC		62	20	14	36	0.7	6	TA209744.0350
0.1406	9/64"	#28	3.571			62	20	14	36	0.7	6	TA209744.0357
0.1417			3.600	#8-36 UNJF		62	20	14	36	0.7	6	TA209744.0360
0.1437			3.650			62	20	14	36	0.7	6	TA209744.0365
0.1457			3.700	M4.5	M4	62	20	14	36	0.8	6	TA209744.0370
0.1496		#25	3.800	STI-#6-32	#8-32 UNC	66	24	17	36	0.8	6	TA209744.0380
0.1516			3.850		#8-36 UNF	66	24	17	36	0.8	6	TA209744.0385
0.1528			3.880			66	24	17	36	0.8	6	TA209744.0388
0.1535			3.900	#10-24 UNC		66	24	17	36	0.8	6	TA209744.0390
0.1563	5/32"		3.970			66	24	17	36	0.8	6	TA209744.0397
0.1575			4.000	M4.5x0.5		66	24	17	36	0.8	6	TA209744.0400
0.1590		#21	4.038			66	24	17	36	0.8	6	TA209744.0404
0.1614			4.100	#10-32 UNF		66	24	17	36	0.8	6	TA209744.0410
0.1634			4.150			66	24	17	36	0.8	6	TA209744.0415
0.1654			4.200	M5 / STI-M4	M4.5	66	24	17	36	0.9	6	TA209744.0420
0.1693		#18	4.300	MJ5x0.8		66	24	17	36	0.9	6	TA209744.0430
0.1713			4.350		#10-24 UNC	66	24	17	36	0.9	6	TA209744.0435
0.1719	11/64"		4.366			66	24	17	36	0.9	6	TA209744.0437
0.1732			4.400	M5x0.75		66	24	17	36	0.9	6	TA209744.0440
0.1752			4.450		#10-32 UNF	66	24	17	36	0.9	6	TA209744.0445
0.1772			4.500	#12-24 UNC		66	24	17	36	0.9	6	TA209744.0450
0.1811			4.600	#12-28 UNF		66	24	17	36	0.9	6	TA209744.0460
0.1831			4.650	#12-24 UNJC	M5	66	24	17	36	0.9	6	TA209744.0465
0.1850		#13	4.700	LK-UNC#12-24		66	24	17	36	1.0	6	TA209744.0470
0.1875	3/16"		4.763	#12-28 UNJF		66	28	20	36	1.0	6	TA209744.0476
0.1890		#12	4.800	#12-32 UNEF	M5x0.5 / STI-M5	66	28	20	36	1.0	6	TA209744.0480
0.1929			4.900			66	28	20	36	1.0	6	TA209744.0490
0.1969			5.000	M6	#12-24 UNC	66	28	20	36	1.0	6	TA209744.0500
0.2008			5.100	MJ6x1	#12-28 UNF	66	28	20	36	1.0	6	TA209744.0510
0.2010		#7	5.106			66	28	20	36	1.0	6	TA209744.0511
0.2031	13/64"		5.159			66	28	20	36	1.0	6	TA209744.0516
0.2047			5.200	1/4-20 UNC		66	28	20	36	1.0	6	TA209744.0520
0.2087			5.300	1/4-20 UNJC		66	28	20	36	1.1	6	TA209744.0530
0.2126			5.400			66	28	20	36	1.1	6	TA209744.0540
0.2130		#3	5.410			66	28	20	36	1.1	6	TA209744.0541
0.2165			5.500	1/4-28 UNF		66	28	20	36	1.1	6	TA209744.0550
0.2187	7/32"		5.556	1/4-28 UNJF		66	28	20	36	1.1	6	TA209744.0556
0.2205			5.600	1/4-32 UNEF	M6	66	28	20	36	1.1	6	TA209744.0560
0.2244			5.700			66	28	20	36	1.1	6	TA209744.0570
0.2264			5.750		1/4-20 UNC	66	28	20	36	1.1	6	TA209744.0575
0.2283			5.800		M6x0.5	66	28	20	36	1.2	6	TA209744.0580
0.2323			5.900			66	28	20	36	1.2	6	TA209744.0590
0.2344	15/64"		5.954		1/4-28 UNF	66	28	20	36	1.2	6	TA209744.0595
0.2362			6.000	M7 / Rd8x1/10		66	28	20	36	1.2	6	TA209744.0600
0.2402			6.100	MJ7x1		79	34	24	36	1.2	8	TA209744.0610
0.2441			6.200	M7x0.75		79	34	24	36	1.2	8	TA209744.0620
0.2480			6.300	M7x0.5, STI-M6		79	34	24	36	1.3	8	TA209744.0630
0.2500	1/4"	E	6.350	1/16-27 NPSF		79	34	24	36	1.3	8	TA209744.0635
0.2520			6.400			79	34	24	36	1.3	8	TA209744.0640
0.2559			6.500	BSW 5/16-18		79	34	24	36	1.3	8	TA209744.0650
0.2570		F	6.528			79	34	24	36	1.3	8	TA209744.0653
0.2598			6.600	5/16-18 UNC	M7	79	34	24	36	1.3	8	TA209744.0660
0.2638			6.700	5/16-18 UNJC	M7x0.75	79	34	24	36	1.3	8	TA209744.0670



MultidRILL™

3 x D - Coolant Fed (continued)

- Double margin design for rounder and straighter holes
- Advanced flute profile designed to enhance chip evacuation of varying materials
- Radius cutting edge for high shearing action
- Unique TIALN-T63 coating resists heat and wear
- 140° drill point angle

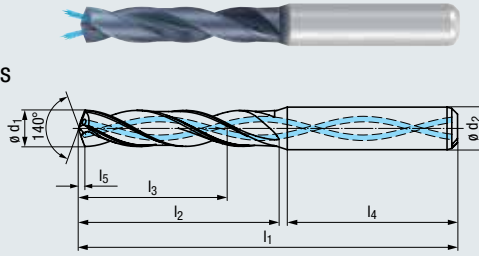

Applications - Materials

P	1.1-5.1
M	1.1-3.1
K	1.1-4.2
N	1.1-1.6, 2.1-2.3
S	1.2-1.3, 2.2-2.3
H	1.1-1.3

Product Finder / Material Descriptions (see pages 4-5)
Cutting Data (see pages 52-53)

Nominal Size ϕd_1 m7 Tolerance				Taps	Roll Form Taps	mm					EDP No. HA SHANK	
Inch	Fraction	Wire letter	mm			l_1	l_2	l_3	l_4	l_5		ϕd_2 h6 Tol.
0.2656	17/64"		6.746			79	34	24	36	1.4	8	TA209744.0675
0.2677			6.800	M8 / G 1/16		79	34	24	36	1.4	8	TA209744.0680
0.2717			6.900	5/16-24 UNF		79	34	24	36	1.4	8	TA209744.0690
0.2756			7.000	5/16-24 UNJF		79	34	24	36	1.4	8	TA209744.0700
0.2795			7.100	MJ8x1		79	41	29	36	1.4	8	TA209744.0710
0.2813	9/32"	K	7.145			79	41	29	36	1.4	8	TA209744.0715
0.2835			7.200	5/16-32 UNEF		79	41	29	36	1.5	8	TA209744.0720
0.2854			7.250		5/16-18 UNC	79	41	29	36	1.5	8	TA209744.0725
0.2874			7.300			79	41	29	36	1.5	8	TA209744.0730
0.2913			7.400			79	41	29	36	1.5	8	TA209744.0740
0.2933			7.450		5/16-24 UNF / M8	79	41	29	36	1.5	8	TA209744.0745
0.2953			7.500	M8x0.5		79	41	29	36	1.5	8	TA209744.0750
0.2969	19/64"		7.541			79	41	29	36	1.5	8	TA209744.0754
0.2992			7.600	Tr9x1.5	M8x1 / STI-M8	79	41	29	36	1.5	8	TA209744.0760
0.3031			7.700		M8x0.75	79	41	29	36	1.5	8	TA209744.0770
0.3071			7.800	M9		79	41	29	36	1.5	8	TA209744.0780
0.3110			7.900	BSW 3/8-16		79	41	29	36	1.6	8	TA209744.0790
0.3125	5/16"		7.938			79	41	29	36	1.6	8	TA209744.0794
0.3150			8.000	3/8-16 UNC		79	41	29	36	1.6	8	TA209744.0800
0.3189			8.100	3/8-16 UNJC		89	47	35	40	1.6	10	TA209744.0810
0.3228			8.200	M9x0.75		89	47	35	40	1.6	10	TA209744.0820
0.3268			8.300	LK-UNC 3/8-16		89	47	35	40	1.6	10	TA209744.0830
0.3281	21/64"		8.334			89	47	35	40	1.6	10	TA209744.0833
0.3307			8.400	STI 5/16-18		89	47	35	40	1.7	10	TA209744.0840
0.3327			8.450			89	47	35	40	1.7	10	TA209744.0845
0.3346			8.500	3/8-24 UNF / M10		89	47	35	40	1.7	10	TA209744.0850
0.3386			8.600	3/8-24 UNJF	M9x1	89	47	35	40	1.7	10	TA209744.0860
0.3425			8.700	3/8-32 UNEF	M9x0.75	89	47	35	40	1.7	10	TA209744.0870
0.3438	11/32"		8.733	1/8-27 NPSC		89	47	35	40	1.7	10	TA209744.0873
0.3465			8.800	M10x1.25	3/8-16 UNC	89	47	35	40	1.7	10	TA209744.0880
0.3504			8.900	MJ10x1.25		89	47	35	40	1.8	10	TA209744.0890
0.3543			9.000	M10x1		89	47	35	40	1.8	10	TA209744.0900
0.3563			9.050		3/8-24 UNF	89	47	35	40	1.8	10	TA209744.0905
0.3583			9.100	1/8-27 NPSM		89	47	35	40	1.8	10	TA209744.0910
0.3594	23/64"		9.129			89	47	35	40	1.8	10	TA209744.0913
0.3622			9.200	M10x0.75		89	47	35	40	1.8	10	TA209744.0920
0.3661			9.300			89	47	35	40	1.8	10	TA209744.0930
0.3681			9.350		M10	89	47	35	40	1.8	10	TA209744.0935
0.3701			9.400	7/16-14 UNC		89	47	35	40	1.9	10	TA209744.0940
0.3720			9.450			89	47	35	40	1.9	10	TA209744.0945
0.3740			9.500	7/16-14 UNJC	STI-M10	89	47	35	40	1.9	10	TA209744.0950
0.3750	3/8"		9.525			89	47	35	40	1.9	10	TA209744.0953
0.3780			9.600		M10x1	89	47	35	40	1.9	10	TA209744.0960
0.3819			9.700	LK-UNC 7/16-14	M10x0.75	89	47	35	40	1.9	10	TA209744.0970
0.3858			9.800	STI 3/8-24		89	47	35	40	1.9	10	TA209744.0980
0.3898			9.900	7/16-20 UNF		89	47	35	40	2.0	10	TA209744.0990
0.3906	25/64"		9.921			89	47	35	40	2.0	10	TA209744.0992
0.3937			10.000	7/16-20 UNJF		89	47	35	40	2.0	10	TA209744.1000
0.3976			10.100			102	55	40	45	2.0	12	TA209744.1010
0.4016			10.200	7/16-28 UNEF		102	55	40	45	2.0	12	TA209744.1020
0.4035			10.250		7/16-14 UNC	102	55	40	45	2.0	12	TA209744.1025
0.4055			10.300			102	55	40	45	2.0	12	TA209744.1030
0.4063	13/32"		10.320			102	55	40	45	2.0	12	TA209744.1032
0.4075			10.350			102	55	40	45	2.0	12	TA209744.1035
0.4094			10.400			102	55	40	45	2.0	12	TA209744.1040
0.4134			10.500	M12x1.5		102	55	40	45	2.1	12	TA209744.1050
0.4154			10.550		7/16-20 UNF	102	55	40	45	2.1	12	TA209744.1055
0.4173			10.600			102	55	40	45	2.1	12	TA209744.1060
0.4213			10.700	LK-M12		102	55	40	45	2.1	12	TA209744.1070
0.4219	27/64"		10.716	1/2-13 UNC		102	55	40	45	2.1	12	TA209744.1072
0.4252			10.800	M12x1.25		102	55	40	45	2.1	12	TA209744.1080
0.4291			10.900	1/2-13 UNJC		102	55	40	45	2.1	12	TA209744.1090
0.4331			11.000	M12x1		102	55	40	45	2.2	12	TA209744.1100
0.4370			11.100	BSF 1/2-16		102	55	40	45	2.2	12	TA209744.1110



MultiDRILL™

3 x D - Coolant Fed (continued)

- Double margin design for rounder and straighter holes
- Advanced flute profile designed to enhance chip evacuation of varying materials
- Radius cutting edge for high shearing action
- Unique TiAlN-T63 coating resists heat and wear
- 140° drill point angle

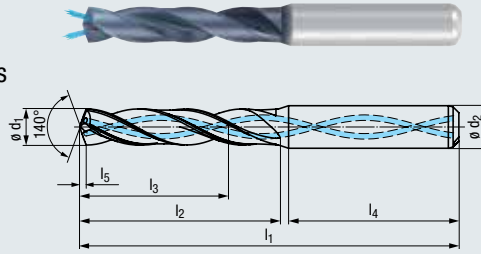

Applications - Materials

P	1.1-5.1
M	1.1-3.1
K	1.1-4.2
N	1.1-1.6, 2.1-2.3
S	1.2-1.3, 2.2-2.3
H	1.1-1.3

Product Finder / Material Descriptions (see pages 4-5)
Cutting Data (see pages 52-53)

Nominal Size Ø d ₁ m7 Tolerance				Taps	Roll Form Taps	mm						EDP No. HA SHANK
Inch	Fraction	Wire letter	mm			l ₁	l ₂	l ₃	l ₄	l ₅	Ø d ₂ h6 Tol.	
0.4375	7/16"		11.113	LK-UNC 1/2-13		102	55	40	45	2.2	12	TA209744.1111
0.4409			11.200			102	55	40	45	2.2	12	TA209744.1120
0.4429			11.250	M12x0.75	M12	102	55	40	45	2.2	12	TA209744.1125
0.4449			11.300			102	55	40	45	2.2	12	TA209744.1130
0.4469			11.350		M12x1.5	102	55	40	45	2.2	12	TA209744.1135
0.4488			11.400	1/4-18 NPSC		102	55	40	45	2.2	12	TA209744.1140
0.4508			11.450		M12x1.25	102	55	40	45	2.2	12	TA209744.1145
0.4528			11.500	1/2-20 UNF		102	55	40	45	2.3	12	TA209744.1150
0.4531	29/64"		11.509			102	55	40	45	2.3	12	TA209744.1151
0.4567			11.600	1/2-20 UNJF	M12x1	102	55	40	45	2.3	12	TA209744.1160
0.4606			11.700			102	55	40	45	2.3	12	TA209744.1170
0.4646			11.800	1/2-28 UNEF	1/2-13 UNC	102	55	40	45	2.3	12	TA209744.1180
0.4685			11.900			102	55	40	45	2.3	12	TA209744.1190
0.4688	15/32"		11.908			102	55	40	45	2.3	12	TA209744.1191
0.4724			12.000	M14		102	55	40	45	2.4	12	TA209744.1200
0.4783			12.150		1/2-20 UNF	107	60	43	45	2.4	14	TA209744.1215
0.4803			12.200	Tr 14x2		107	60	43	45	2.4	14	TA209744.1220
0.4844	31/64"		12.304	9/16-12 UNC		107	60	43	45	2.4	14	TA209744.1230
0.4921			12.500	M14x1.5		107	60	43	45	2.4	14	TA209744.1250
0.4941			12.550		G 1/4-19	107	60	43	45	2.4	14	TA209744.1255
0.4961			12.600			107	60	43	45	2.5	14	TA209744.1260
0.5000	1/2"		12.700	LK-UNC 9/16-12		107	60	43	45	2.5	14	TA209744.1270
0.5039			12.800	M14x1.25		107	60	43	45	2.5	14	TA209744.1280
0.5118			13.000	9/16-18 UNJF		107	60	43	45	2.5	14	TA209744.1300
0.5157			13.100	STI-UNF 1/2-20	M14	107	60	43	45	2.6	14	TA209744.1310
0.5236			13.300	9/16-24 UNEF	9/16-12 UNC	107	60	43	45	2.6	14	TA209744.1330
0.5256			13.350		M14x1.5	107	60	43	45	2.6	14	TA209744.1335
0.5295			13.450		M14x1.25	107	60	43	45	2.6	14	TA209744.1345
0.5313	17/32"		13.495	5/8-11 UNC		107	60	43	45	2.6	14	TA209744.1349
0.5315			13.500			107	60	43	45	2.6	14	TA209744.1350
0.5354			13.600			107	60	43	45	2.6	14	TA209744.1360
0.5374			13.650	5/8-11 UNJC	9/16-18 UNF	107	60	43	45	2.7	14	TA209744.1365
0.5394			13.700			107	60	43	45	2.7	14	TA209744.1370
0.5433			13.800			107	60	43	45	2.7	14	TA209744.1380
0.5469	35/64"		13.891			107	60	43	45	2.7	14	TA209744.1389
0.5512			14.000	M16 / M15x1		107	60	43	45	2.7	14	TA209744.1400
0.5551			14.100			115	65	45	48	2.8	16	TA209744.1410
0.5625	9/16"		14.290			115	65	45	48	2.8	16	TA209744.1429
0.5709			14.500	5/8-18 UNF		115	65	45	48	2.8	16	TA209744.1450
0.5748			14.600	5/8-18 UNJF	M15x1	115	65	45	48	2.9	16	TA209744.1460
0.5781	37/64"		14.684	3/8-18 NPSC		115	65	45	48	2.9	16	TA209744.1468
0.5827			14.800		5/8-11 UNC	115	65	45	48	2.9	16	TA209744.1480
0.5906			15.000	M16x1		115	65	45	48	2.9	16	TA209744.1500
0.5938	19/32"		15.083			115	65	45	48	2.9	16	TA209744.1508
0.5945			15.100		M16	115	65	45	48	2.9	16	TA209744.1510
0.6043			15.350			115	65	45	48	2.9	16	TA209744.1535
0.6102			15.500	M18		115	65	45	48	3.0	16	TA209744.1550
0.6142			15.600		M16x1	115	65	45	48	3.0	16	TA209744.1560
0.6250	5/8"		15.875			115	65	45	48	3.1	16	TA209744.1588
0.6299			16.000	M18x2		115	65	45	48	3.1	16	TA209744.1600
0.6406	41/64"		16.272			123	73	51	48	3.1	18	TA209744.1627
0.6496			16.500	STI-UNC 5/8-11		123	73	51	48	3.2	18	TA209744.1650
0.6563	21/32"		16.669	3/4-10 UNC		123	73	51	48	3.2	18	TA209744.1667
0.6693			17.000	M18x1		123	73	51	48	3.3	18	TA209744.1700
0.6875	11/16"		17.460			123	73	51	48	3.3	18	TA209744.1746
0.6890			17.500	3/4-16 UNF / M20		123	73	51	48	3.4	18	TA209744.1750
0.7087			18.000	M20x2 / LK-M16		123	73	51	48	3.5	18	TA209744.1800
0.7500	3/4"		19.050			131	79	55	50	3.7	20	TA209744.1905



MultidRILL™

5 x D - Coolant Fed

- Double margin design for rounder and straighter holes
- Advanced flute profile designed to enhance chip evacuation of varying materials
- Radius cutting edge for high shearing action
- Unique TIALN-T63 coating resists heat and wear
- 140° drill point angle

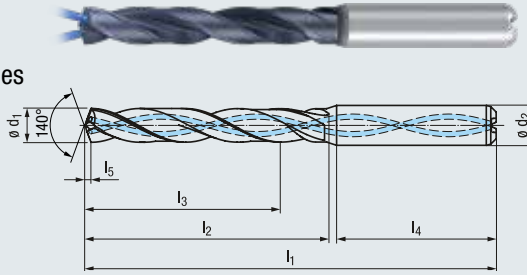

Applications - Materials

P	1.1-5.1
M	1.1-3.1
K	1.1-4.2
N	1.1-1.6, 2.1-2.3
S	1.2-1.3, 2.2-2.3
H	1.1-1.3

Product Finder / Material Descriptions (see pages 4-5)
Cutting Data (see pages 52-53)

Nominal Size Ø d ₁ m7 Tolerance				Taps	Roll Form Taps	mm					EDP No. HA SHANK	
Inch	Fraction	Wire letter	mm			l ₁	l ₂	l ₃	l ₄	l ₅	Ø d ₂ h6 Tol.	
0.1181			3.000	#6-40 UNF		66	28	23	36	0.6	6	TA219744.0300
0.1220			3.100	STI-#4-40		66	28	23	36	0.6	6	TA219744.0310
0.1240			3.150	M3.5x0.35	#6-32 UNC	66	28	23	36	0.6	6	TA219744.0315
0.1250	1/8"		3.175			66	28	23	36	0.6	6	TA219744.0318
0.1260			3.200	BSW ⁵ / ₃₂ -32	#6-40 UNF	66	28	23	36	0.6	6	TA219744.0320
0.1268			3.220			66	28	23	36	0.7	6	TA219744.0322
0.1280			3.250		M3.5	66	28	23	36	0.7	6	TA219744.0325
0.1299			3.300	M4		66	28	23	36	0.7	6	TA219744.0330
0.1319			3.350			66	28	23	36	0.7	6	TA219744.0335
0.1331			3.380		M3.5x0.35	66	28	23	36	0.7	6	TA219744.0338
0.1339			3.400	MJ4x0.7		66	28	23	36	0.7	6	TA219744.0340
0.1378			3.500	#8-32 UNC		66	28	23	36	0.7	6	TA219744.0350
0.1406	9/64"	#28	3.571			66	28	23	36	0.7	6	TA219744.0357
0.1417			3.600	#8-36 UNJF		66	28	23	36	0.7	6	TA219744.0360
0.1437			3.650			66	28	23	36	0.7	6	TA219744.0365
0.1457			3.700	M4.5	M4	66	28	23	36	0.8	6	TA219744.0370
0.1496		#25	3.800	STI-#6-32	#8-32 UNC	74	36	29	36	0.8	6	TA219744.0380
0.1516			3.850		#8-36 UNF	74	36	29	36	0.8	6	TA219744.0385
0.1528			3.880			74	36	29	36	0.8	6	TA219744.0388
0.1535			3.900	#10-24 UNC		74	36	29	36	0.8	6	TA219744.0390
0.1563	5/32"		3.970			74	36	29	36	0.8	6	TA219744.0397
0.1575			4.000	M4.5x0.5		74	36	29	36	0.8	6	TA219744.0400
0.1590		#21	4.038			74	36	29	36	0.8	6	TA219744.0404
0.1614			4.100	#10-32 UNF		74	36	29	36	0.8	6	TA219744.0410
0.1634			4.150			74	36	29	36	0.8	6	TA219744.0415
0.1654			4.200	M5 / STI-M4	M4.5	74	36	29	36	0.8	6	TA219744.0420
0.1693		#18	4.300	MJ5x0.8		74	36	29	36	0.8	6	TA219744.0430
0.1713			4.350		#10-24 UNC	74	36	29	36	0.8	6	TA219744.0435
0.1719	11/64"		4.366			74	36	29	36	0.8	6	TA219744.0437
0.1732			4.400	M5x0.75		74	36	29	36	0.8	6	TA219744.0440
0.1752			4.450		#10-32 UNF	74	36	29	36	0.9	6	TA219744.0445
0.1772			4.500	#12-24 UNC		74	36	29	36	0.9	6	TA219744.0450
0.1811			4.600	#12-28 UNF		74	36	29	36	0.9	6	TA219744.0460
0.1831			4.650	#12-24 UNJC	M5	74	36	29	36	0.9	6	TA219744.0465
0.1850		#13	4.700	LK-UNC#12-24		74	36	29	36	0.9	6	TA219744.0470
0.1875	3/16"		4.763	#12-28 UNJF		82	44	35	36	1.0	6	TA219744.0476
0.1890		#12	4.800	#12-32 UNEF	M5x0.5 / STI-M5	82	44	35	36	1.0	6	TA219744.0480
0.1929			4.900			82	44	35	36	1.0	6	TA219744.0490
0.1969			5.000	M6	#12-24 UNC	82	44	35	36	1.0	6	TA219744.0500
0.2008			5.100	MJ6x1	#12-28 UNF	82	44	35	36	1.0	6	TA219744.0510
0.2010		#7	5.106			82	44	35	36	1.0	6	TA219744.0511
0.2031	13/64"		5.159			82	44	35	36	1.0	6	TA219744.0516
0.2047			5.200	1/4-20 UNC		82	44	35	36	1.0	6	TA219744.0520
0.2087			5.300	1/4-20 UNJC		82	44	35	36	1.1	6	TA219744.0530
0.2126			5.400			82	44	35	36	1.1	6	TA219744.0540
0.2130		#3	5.410			82	44	35	36	1.1	6	TA219744.0541
0.2165			5.500	1/4-28 UNF		82	44	35	36	1.1	6	TA219744.0550
0.2187	7/32"		5.556	1/4-28 UNJF		82	44	35	36	1.1	6	TA219744.0556
0.2205			5.600	1/4-32 UNEF	M6	82	44	35	36	1.1	6	TA219744.0560
0.2244			5.700			82	44	35	36	1.1	6	TA219744.0570
0.2264			5.750		1/4-20 UNC	82	44	35	36	1.2	6	TA219744.0575
0.2283			5.800		M6x0.5	82	44	35	36	1.2	6	TA219744.0580
0.2323			5.900			82	44	35	36	1.2	6	TA219744.0590
0.2344	15/64"		5.954		1/4-28 UNF	82	44	35	36	1.2	6	TA219744.0595
0.2362			6.000	M7 / Rd8x ¹ / ₁₀		82	44	35	36	1.2	6	TA219744.0600
0.2402			6.100	MJ7x1		91	53	43	36	1.2	8	TA219744.0610
0.2441			6.200	M7x0.75		91	53	43	36	1.2	8	TA219744.0620
0.2480			6.300	M7x0.5, STI-M6		91	53	43	36	1.3	8	TA219744.0630
0.2500	1/4"	E	6.350	1/16-27 NPSF		91	53	43	36	1.3	8	TA219744.0635
0.2520			6.400			91	53	43	36	1.3	8	TA219744.0640
0.2559			6.500	BSW ⁵ / ₁₆ -18		91	53	43	36	1.3	8	TA219744.0650
0.2570		F	6.528			91	53	43	36	1.3	8	TA219744.0653
0.2598			6.600	5/16-18 UNC	M7	91	53	43	36	1.3	8	TA219744.0660
0.2638			6.700	5/16-18 UNJC	M7x0.75	91	53	43	36	1.3	8	TA219744.0670



MultiDRILL™

5 x D - Coolant Fed (continued)

- Double margin design for rounder and straighter holes
- Advanced flute profile designed to enhance chip evacuation of varying materials
- Radius cutting edge for high shearing action
- Unique TiAlN-T63 coating resists heat and wear
- 140° drill point angle

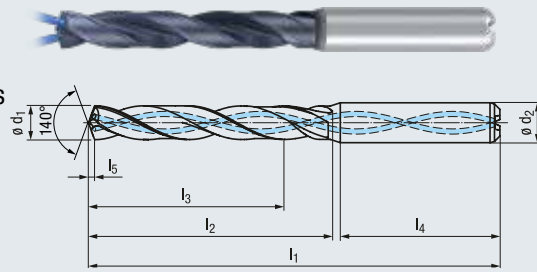

Applications - Materials

P	1.1-5.1
M	1.1-3.1
K	1.1-4.2
N	1.1-1.6, 2.1-2.3
S	1.2-1.3, 2.2-2.3
H	1.1-1.3

Product Finder / Material Descriptions (see pages 4-5)
Cutting Data (see pages 52-53)

Nominal Size Ø d ₁ m7 Tolerance			Taps	Roll Form Taps	mm						EDP No. HA SHANK
Inch	Fraction	Wire letter			l ₁	l ₂	l ₃	l ₄	l ₅	Ø d ₂ h6 Tol.	
0.2656	17/64"				91	53	43	36	1.3	8	TA219744.0675
0.2677			M8 / G 1/16		91	53	43	36	1.4	8	TA219744.0680
0.2717			5/16-24 UNF		91	53	43	36	1.4	8	TA219744.0690
0.2756			5/16-24 UNJF		91	53	43	36	1.4	8	TA219744.0700
0.2795			MJ8x1		91	53	43	36	1.4	8	TA219744.0710
0.2813	9/32"	K			91	53	43	36	1.4	8	TA219744.0715
0.2835			5/16-32 UNEF		91	53	43	36	1.4	8	TA219744.0720
0.2854				5/16-18 UNC	91	53	43	36	1.5	8	TA219744.0725
0.2874					91	53	43	36	1.5	8	TA219744.0730
0.2913					91	53	43	36	1.5	8	TA219744.0740
0.2933				5/16-24 UNF / M8	91	53	43	36	1.5	8	TA219744.0745
0.2953			M8x0.5		91	53	43	36	1.5	8	TA219744.0750
0.2969	19/64"				91	53	43	36	1.5	8	TA219744.0754
0.2992			Tr9x1.5	M8x1 / STI-M8	91	53	43	36	1.5	8	TA219744.0760
0.3031				M8x0.75	91	53	43	36	1.5	8	TA219744.0770
0.3071			M9		91	53	43	36	1.6	8	TA219744.0780
0.3110			BSW 3/8-16		91	53	43	36	1.6	8	TA219744.0790
0.3125	5/16"				91	53	43	36	1.6	8	TA219744.0794
0.3150			3/8-16 UNC		91	53	43	36	1.6	8	TA219744.0800
0.3189			3/8-16 UNJC		103	61	49	40	1.6	10	TA219744.0810
0.3228			M9x0.75		103	61	49	40	1.6	10	TA219744.0820
0.3268			LK-UNC 3/8-16		103	61	49	40	1.7	10	TA219744.0830
0.3281	21/64"				103	61	49	40	1.7	10	TA219744.0833
0.3307			STI 5/16-18		103	61	49	40	1.7	10	TA219744.0840
0.3327					103	61	49	40	1.7	10	TA219744.0845
0.3346			3/8-24 UNF / M10		103	61	49	40	1.7	10	TA219744.0850
0.3386			3/8-24 UNJF	M9x1	103	61	49	40	1.7	10	TA219744.0860
0.3425			3/8-32 UNEF	M9x0.75	103	61	49	40	1.7	10	TA219744.0870
0.3438	11/32"		1/8-27 NPSC		103	61	49	40	1.7	10	TA219744.0873
0.3465			M10x1.25	3/8-16 UNC	103	61	49	40	1.8	10	TA219744.0880
0.3504			MJ10x1.25		103	61	49	40	1.8	10	TA219744.0890
0.3543			M10x1		103	61	49	40	1.8	10	TA219744.0900
0.3563				3/8-24 UNF	103	61	49	40	1.8	10	TA219744.0905
0.3583			1/8-27 NPSM		103	61	49	40	1.8	10	TA219744.0910
0.3594	23/64"				103	61	49	40	1.8	10	TA219744.0913
0.3622			M10x0.75		103	61	49	40	1.8	10	TA219744.0920
0.3661					103	61	49	40	1.9	10	TA219744.0930
0.3681				M10	103	61	49	40	1.9	10	TA219744.0935
0.3701			7/16-14 UNC		103	61	49	40	1.9	10	TA219744.0940
0.3720					103	61	49	40	1.9	10	TA219744.0945
0.3740			7/16-14 UNJC	STI-M10	103	61	49	40	1.9	10	TA219744.0950
0.3750	3/8"				103	61	49	40	1.9	10	TA219744.0953
0.3780				M10x1	103	61	49	40	1.9	10	TA219744.0960
0.3819			LK-UNC 7/16-14	M10x0.75	103	61	49	40	1.9	10	TA219744.0970
0.3858			STI 3/8-24		103	61	49	40	2.0	10	TA219744.0980
0.3898			7/16-20 UNF		103	61	49	40	2.0	10	TA219744.0990
0.3906	25/64"				103	61	49	40	2.0	10	TA219744.0992
0.3937			7/16-20 UNJF		103	61	49	40	2.0	10	TA219744.1000
0.3976					118	71	56	45	2.0	12	TA219744.1010
0.4016			7/16-28 UNEF		118	71	56	45	2.0	12	TA219744.1020
0.4035				7/16-14 UNC	118	71	56	45	2.1	12	TA219744.1025
0.4055					118	71	56	45	2.1	12	TA219744.1030
0.4063	13/32"				118	71	56	45	2.1	12	TA219744.1032
0.4075					118	71	56	45	2.1	12	TA219744.1035
0.4094					118	71	56	45	2.1	12	TA219744.1040
0.4134			M12x1.5		118	71	56	45	2.1	12	TA219744.1050
0.4154				7/16-20 UNF	118	71	56	45	2.1	12	TA219744.1055
0.4173					118	71	56	45	2.1	12	TA219744.1060
0.4213			LK-M12		118	71	56	45	2.1	12	TA219744.1070
0.4219	27/64"		1/2-13 UNC		118	71	56	45	2.1	12	TA219744.1072
0.4252			M12x1.25		118	71	56	45	2.1	12	TA219744.1080
0.4291			1/2-13 UNJC		118	71	56	45	2.1	12	TA219744.1090
0.4331			M12x1		118	71	56	45	2.2	12	TA219744.1100
0.4370			BSF 1/2-16		118	71	56	45	2.2	12	TA219744.1110



MultidRILL™

5 x D - Coolant Fed (continued)

- Double margin design for rounder and straighter holes
- Advanced flute profile designed to enhance chip evacuation of varying materials
- Radius cutting edge for high shearing action
- Unique TIALN-T63 coating resists heat and wear
- 140° drill point angle

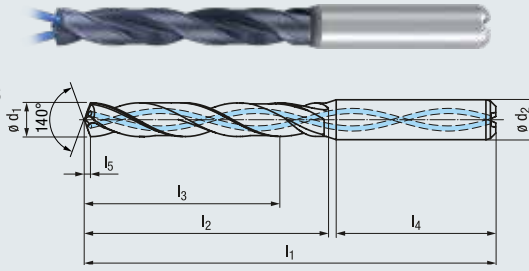

Applications - Materials

P	1.1-5.1
M	1.1-3.1
K	1.1-4.2
N	1.1-1.6, 2.1-2.3
S	1.2-1.3, 2.2-2.3
H	1.1-1.3

Product Finder / Material Descriptions (see pages 4-5)
Cutting Data (see pages 52-53)

Nominal Size Ø d ₁ m7 Tolerance				Taps	Roll Form Taps	mm					EDP No. HA SHANK	
Inch	Fraction	Wire letter	mm			l ₁	l ₂	l ₃	l ₄	l ₅	Ø d ₂ h6 Tol.	
0.4375	7/16"		11.113	LK-UNC 1/2-13		118	71	56	45	2.2	12	TA219744.1111
0.4409			11.200			118	71	56	45	2.2	12	TA219744.1120
0.4429			11.250	M12x0.75	M12	118	71	56	45	2.3	12	TA219744.1125
0.4449			11.300			118	71	56	45	2.3	12	TA219744.1130
0.4469			11.350		M12x1.5	118	71	56	45	2.3	12	TA219744.1135
0.4488			11.400	1/4-18 NPSC		118	71	56	45	2.3	12	TA219744.1140
0.4508			11.450		M12x1.25	118	71	56	45	2.2	12	TA219744.1145
0.4528			11.500	1/2-20 UNF		118	71	56	45	2.3	12	TA219744.1150
0.4531	29/64"		11.509			118	71	56	45	2.3	12	TA219744.1151
0.4567			11.600	1/2-20 UNJF	M12x1	118	71	56	45	2.3	12	TA219744.1160
0.4606			11.700			118	71	56	45	2.3	12	TA219744.1170
0.4646			11.800	1/2-28 UNEF	1/2-13 UNC	118	71	56	45	2.4	12	TA219744.1180
0.4685			11.900			118	71	56	45	2.4	12	TA219744.1190
0.4688	15/32"		11.908			118	71	56	45	2.4	12	TA219744.1191
0.4724			12.000	M14		118	71	56	45	2.4	12	TA219744.1200
0.4783			12.150		1/2-20 UNF	124	77	56	45	2.4	14	TA219744.1215
0.4803			12.200	Tr 14x2		124	77	56	45	2.4	14	TA219744.1220
0.4844	31/64"		12.304	9/16-12 UNC		124	77	60	45	2.4	14	TA219744.1230
0.4921			12.500	M14x1.5		124	77	60	45	2.5	14	TA219744.1250
0.4941			12.550		G 1/4-19	124	77	60	45	2.5	14	TA219744.1255
0.4961			12.600			124	77	60	45	2.5	14	TA219744.1260
0.5000	1/2"		12.700	LK-UNC 9/16-12		124	77	60	45	2.5	14	TA219744.1270
0.5039			12.800	M14x1.25		124	77	60	45	2.6	14	TA219744.1280
0.5118			13.000	9/16-18 UNJF		124	77	60	45	2.6	14	TA219744.1300
0.5157			13.100	STI-UNF 1/2-20	M14	124	77	60	45	2.6	14	TA219744.1310
0.5236			13.300	9/16-24 UNEF	9/16-12 UNC	124	77	60	45	2.7	14	TA219744.1330
0.5256			13.350		M14x1.5	124	77	60	45	2.7	14	TA219744.1335
0.5295			13.450		M14x1.25	124	77	60	45	2.7	14	TA219744.1345
0.5313	17/32"		13.495	5/8-11 UNC		124	77	60	45	2.7	14	TA219744.1349
0.5315			13.500			124	77	60	45	2.7	14	TA219744.1350
0.5354			13.600			124	77	60	45	2.7	14	TA219744.1360
0.5374			13.650	5/8-11 UNJC	9/16-18 UNF	124	77	60	45	2.7	14	TA219744.1365
0.5394			13.700			124	77	60	45	2.7	14	TA219744.1370
0.5433			13.800			124	77	60	45	2.7	14	TA219744.1380
0.5469	35/64"		13.891			124	77	60	45	2.7	14	TA219744.1389
0.5512			14.000	M16 / M15x1		124	77	60	45	2.7	14	TA219744.1400
0.5551			14.100			133	83	60	45	2.8	16	TA219744.1410
0.5625	9/16"		14.290			133	83	63	48	2.8	16	TA219744.1429
0.5709			14.500	5/8-18 UNF		133	83	63	48	2.9	16	TA219744.1450
0.5748			14.600	5/8-18 UNJF	M15x1	133	83	63	48	2.9	16	TA219744.1460
0.5781	37/64"		14.684	5/8-18 NPSC		133	83	63	48	2.9	16	TA219744.1468
0.5827			14.800		5/8-11 UNC	133	83	63	48	2.9	16	TA219744.1480
0.5906			15.000	M16x1		133	83	63	48	3.0	16	TA219744.1500
0.5938	19/32"		15.083			133	83	63	48	3.0	16	TA219744.1508
0.5945			15.100			133	83	63	48	3.0	16	TA219744.1510
0.6043			15.350		M16	133	83	63	48	3.0	16	TA219744.1535
0.6102			15.500	M18		133	83	63	48	3.1	16	TA219744.1550
0.6142			15.600		M16x1	133	83	63	48	3.1	16	TA219744.1560
0.6250	5/8"		15.875			133	83	63	48	3.1	16	TA219744.1588
0.6299			16.000	M18x2		133	83	63	48	3.2	16	TA219744.1600
0.6406	41/64"		16.272			143	93	71	48	3.3	18	TA219744.1627
0.6496			16.500	STI-UNC 5/8-11		143	93	71	48	3.4	18	TA219744.1650
0.6563	21/32"		16.669	3/4-10 UNC		143	93	71	48	3.4	18	TA219744.1667
0.6693			17.000	M18x1		143	93	71	48	3.5	18	TA219744.1700
0.6875	11/16"		17.463			143	93	71	48	3.5	18	TA219744.1746
0.6890			17.500	3/4-16 UNF / M20		143	93	71	48	3.5	18	TA219744.1750
0.7087			18.000	M20x2 / LK-M16		143	93	71	48	3.6	18	TA219744.1800
0.7500	3/4"		19.050			153	101	77	50	3.8	20	TA219744.1905



MultiDRILL™

8 x D - Coolant Fed

- Double margin design for rounder and straighter holes
- Unique TiAlN-T63 coating for heat and wear resistance
- 135° drill point angle
- Preparatory center drilling recommended with 142° NC Spot drill

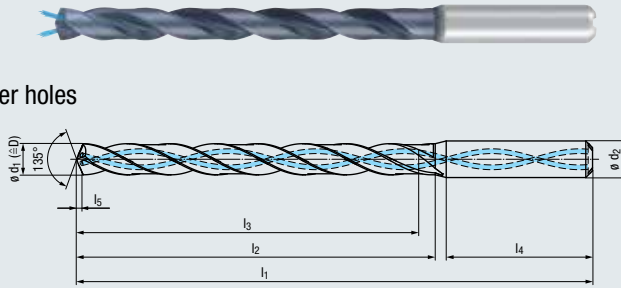

Applications - Materials

P	1.1-5.1
M	1.1-3.1
K	1.1-4.2
N	1.1-1.6, 2.1-2.8
S	1.2-1.3, 2.2-2.3
H	1.1-1.3

Product Finder / Material Descriptions (see pages 4-5)
Cutting Data (see pages 52-53)

Nominal Size ø d ₁ m7 Tolerance				Taps	Roll Form Taps	mm					EDP No. HA SHANK	
Inch	Fraction	Wire letter	mm			l ₁	l ₂	l ₃	l ₄	l ₅	ø d ₂ h6 Tol.	
0.1181			3.000	#6-40 UNF		78	38	30	36	0.6	6	TA229744.0300
0.1220			3.100	STI-#4-40		78	38	30	36	0.6	6	TA229744.0310
0.1240			3.150	M3.5x0.35	#6-32 UNC	78	38	30	36	0.7	6	TA229744.0315
0.1250	1/8"		3.175			78	38	30	36	0.7	6	TA229744.0318
0.1260			3.200	BSW 5/32-32	#6-40 UNF	78	38	30	36	0.7	6	TA229744.0320
0.1268			3.220			78	38	30	36	0.7	6	TA229744.0322
0.1280			3.250		M3.5	78	38	30	36	0.7	6	TA229744.0325
0.1299			3.300	M4		78	38	30	36	0.7	6	TA229744.0330
0.1319			3.350			78	38	30	36	0.7	6	TA229744.0335
0.1331			3.380		M3.5x0.35	78	38	30	36	0.7	6	TA229744.0338
0.1339			3.400	MJ4x0.7		78	38	30	36	0.7	6	TA229744.0340
0.1378			3.500	#8-32 UNC		78	38	30	36	0.7	6	TA229744.0350
0.1406	9/64"	#28	3.571			78	38	30	36	0.7	6	TA229744.0357
0.1417			3.600	#8-36 UNJF		78	38	30	36	0.7	6	TA229744.0360
0.1437			3.650			78	38	30	36	0.7	6	TA229744.0365
0.1457			3.700	M4.5	M4	78	38	30	36	0.8	6	TA229744.0370
0.1496		#25	3.800	STI-#6-32	#8-32 UNC	88	48	38	36	0.8	6	TA229744.0380
0.1516			3.850		#8-36 UNF	88	48	38	36	0.8	6	TA229744.0385
0.1528			3.880			88	48	38	36	0.8	6	TA229744.0388
0.1535			3.900	#10-24 UNC		88	48	38	36	0.8	6	TA229744.0390
0.1563	5/32"		3.970			88	48	38	36	0.8	6	TA229744.0397
0.1575			4.000	M4.5x0.5		88	48	38	36	0.8	6	TA229744.0400
0.1590		#21	4.038			88	48	38	36	0.8	6	TA229744.0404
0.1614			4.100	#10-32 UNF		88	48	38	36	0.8	6	TA229744.0410
0.1634			4.150			88	48	38	36	0.8	6	TA229744.0415
0.1654			4.200	M5 / STI-M4	M4.5	88	48	38	36	0.9	6	TA229744.0420
0.1693		#18	4.300	MJ5x0.8		88	48	38	36	0.9	6	TA229744.0430
0.1713			4.350		#10-24 UNC	88	48	38	36	0.9	6	TA229744.0435
0.1719	11/64"		4.366			88	48	38	36	0.9	6	TA229744.0437
0.1732			4.400	M5x0.75		88	48	38	36	0.9	6	TA229744.0440
0.1752			4.450		#10-32 UNF	88	48	38	36	0.9	6	TA229744.0445
0.1772			4.500	#12-24 UNC		88	48	38	36	0.9	6	TA229744.0450
0.1811			4.600	#12-28 UNF		88	48	38	36	1.0	6	TA229744.0460
0.1831			4.650	#12-24 UNJC	M5	88	48	38	36	1.0	6	TA229744.0465
0.1850		#13	4.700	LK-UNC#12-24		88	48	38	36	1.0	6	TA229744.0470
0.1875	3/16"		4.763	#12-28 UNJF		97	60	48	36	1.0	6	TA229744.0476
0.1890		#12	4.800	#12-32 UNEF	M5x0.5 / STI-M5	97	60	48	36	1.0	6	TA229744.0480
0.1929			4.900			97	60	48	36	1.0	6	TA229744.0490
0.1969			5.000	M6	#12-24 UNC	97	60	48	36	1.0	6	TA229744.0500
0.2008			5.100	MJ6x1	#12-28 UNF	97	60	48	36	1.1	6	TA229744.0510
0.2010		#7	5.106			97	60	48	36	1.1	6	TA229744.0511
0.2031	13/64"		5.159			97	60	48	36	1.1	6	TA229744.0516
0.2047			5.200	1/4-20 UNC		97	60	48	36	1.1	6	TA229744.0520
0.2087			5.300	1/4-20 UNJC		97	60	48	36	1.1	6	TA229744.0530
0.2126			5.400			97	60	48	36	1.1	6	TA229744.0540
0.2130		#3	5.410			97	60	48	36	1.1	6	TA229744.0541
0.2165			5.500	1/4-28 UNF		97	60	48	36	1.1	6	TA229744.0550
0.2187	7/32"		5.556	1/4-28 UNJF		97	60	48	36	1.1	6	TA229744.0556
0.2205			5.600	1/4-32 UNEF	M6	97	60	48	36	1.2	6	TA229744.0560
0.2244			5.700			97	60	48	36	1.2	6	TA229744.0570
0.2264			5.750		1/4-20 UNC	97	60	48	36	1.2	6	TA229744.0575
0.2283			5.800		M6x0.5	97	60	48	36	1.2	6	TA229744.0580
0.2323			5.900			97	60	48	36	1.2	6	TA229744.0590
0.2344	15/64"		5.954		1/4-28 UNF	97	60	48	36	1.2	6	TA229744.0595
0.2362			6.000	M7 / Rd8x1/10		97	60	48	36	1.2	6	TA229744.0600
0.2402			6.100	MJ7x1		107	70	56	36	1.3	8	TA229744.0610
0.2441			6.200	M7x0.75		107	70	56	36	1.3	8	TA229744.0620
0.2480			6.300	M7x0.5, STI-M6		107	70	56	36	1.3	8	TA229744.0630
0.2500	1/4"	E	6.350	1/16-27 NPSF		107	70	56	36	1.3	8	TA229744.0635
0.2520			6.400			107	70	56	36	1.3	8	TA229744.0640
0.2559			6.500	BSW 5/16-18		107	70	56	36	1.3	8	TA229744.0650
0.2570		F	6.528			107	70	56	36	1.3	8	TA229744.0653
0.2598			6.600	5/16-18 UNC	M7	107	70	56	36	1.4	8	TA229744.0660
0.2638			6.700	5/16-18 UNJC	M7x0.75	107	70	56	36	1.4	8	TA229744.0670



MultidRILL™

8 x D - Coolant Fed (continued)

- Double margin design for rounder and straighter holes
- Unique TIALN-T63 coating for heat and wear resistance
- 135° drill point angle
- Preparatory center drilling recommended with 142° NC Spot drill

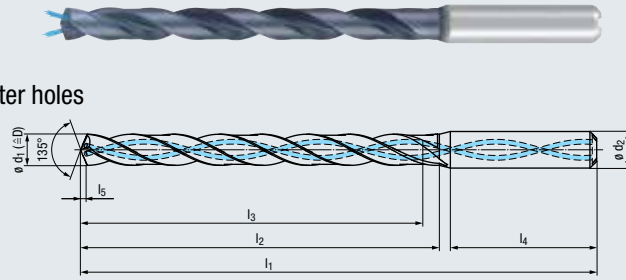

Applications - Materials

P	1.1-5.1
M	1.1-3.1
K	1.1-4.2
N	1.1-1.6, 2.1-2.8
S	1.2-1.3, 2.2-2.3
H	1.1-1.3

Product Finder / Material Descriptions (see pages 4-5)
Cutting Data (see pages 52-53)

Nominal Size Ø d ₁ m7 Tolerance				Taps	Roll Form Taps	mm						EDP No. HA SHANK
Inch	Fraction	Wire letter	mm			l ₁	l ₂	l ₃	l ₄	l ₅	Ø d ₂ h6 Tol.	
0.2656	17/64"		6.746			107	70	56	36	1.4	8	TA229744.0675
0.2677			6.800	M8 / G 1/16		107	70	56	36	1.4	8	TA229744.0680
0.2717			6.900	5/16-24 UNF		107	70	56	36	1.4	8	TA229744.0690
0.2756			7.000	5/16-24 UNJF		107	70	56	36	1.4	8	TA229744.0700
0.2795			7.100	MJ8x1		117	80	64	36	1.5	8	TA229744.0710
0.2813	9/32"	K	7.145			117	80	64	36	1.5	8	TA229744.0715
0.2835			7.200	5/16-32 UNEF		117	80	64	36	1.5	8	TA229744.0720
0.2854			7.250		5/16-18 UNC	117	80	64	36	1.5	8	TA229744.0725
0.2874			7.300			117	80	64	36	1.5	8	TA229744.0730
0.2913			7.400			117	80	64	36	1.5	8	TA229744.0740
0.2933			7.450		5/16-24 UNF / M8	117	80	64	36	1.5	8	TA229744.0745
0.2953			7.500	M8x0.5		117	80	64	36	1.6	8	TA229744.0750
0.2969	19/64"		7.541			117	80	64	36	1.6	8	TA229744.0754
0.2992			7.600	Tr9x1.5	M8x1 / STI-M8	117	80	64	36	1.6	8	TA229744.0760
0.3031			7.700		M8x0.75	117	80	64	36	1.6	8	TA229744.0770
0.3071			7.800	M9		117	80	64	36	1.6	8	TA229744.0780
0.3110			7.900	BSW 3/8-16		117	80	64	36	1.6	8	TA229744.0790
0.3125	5/16"		7.938			117	80	64	36	1.6	8	TA229744.0794
0.3150			8.000	3/8-16 UNC		117	80	64	36	1.7	8	TA229744.0800
0.3189			8.100	3/8-16 UNJC		141	100	80	40	1.7	10	TA229744.0810
0.3228			8.200	M9x0.75		141	100	80	40	1.7	10	TA229744.0820
0.3268			8.300	LK-UNC 3/8-16		141	100	80	40	1.7	10	TA229744.0830
0.3281	21/64"		8.334			141	100	80	40	1.7	10	TA229744.0833
0.3307			8.400	STI 5/16-18		141	100	80	40	1.7	10	TA229744.0840
0.3327			8.450			141	100	80	40	1.7	10	TA229744.0845
0.3346			8.500	3/8-24 UNF / M10		141	100	80	40	1.8	10	TA229744.0850
0.3386			8.600	3/8-24 UNJF	M9x1	141	100	80	40	1.8	10	TA229744.0860
0.3425			8.700	3/8-32 UNEF	M9x0.75	141	100	80	40	1.8	10	TA229744.0870
0.3438	11/32"		8.733	1/8-27 NPSC		141	100	80	40	1.8	10	TA229744.0873
0.3465			8.800	M10x1.25	3/8-16 UNC	141	100	80	40	1.8	10	TA229744.0880
0.3504			8.900	MJ10x1.25		141	100	80	40	1.8	10	TA229744.0890
0.3543			9.000	M10x1		141	100	80	40	1.9	10	TA229744.0900
0.3563			9.050		3/8-24 UNF	141	100	80	40	1.9	10	TA229744.0905
0.3583			9.100	1/8-27 NPSM		141	100	80	40	1.9	10	TA229744.0910
0.3594	23/64"		9.129			141	100	80	40	1.9	10	TA229744.0913
0.3622			9.200	M10x0.75		141	100	80	40	1.9	10	TA229744.0920
0.3661			9.300			141	100	80	40	1.9	10	TA229744.0930
0.3681			9.350		M10	141	100	80	40	1.9	10	TA229744.0935
0.3701			9.400	7/16-14 UNC		141	100	80	40	1.9	10	TA229744.0940
0.3720			9.450			141	100	80	40	1.9	10	TA229744.0945
0.3740			9.500	7/16-14 UNJC	STI-M10	141	100	80	40	2.0	10	TA229744.0950
0.3750	3/8"		9.525			141	100	80	40	2.0	10	TA229744.0953
0.3780			9.600		M10x1	141	100	80	40	2.0	10	TA229744.0960
0.3819			9.700	LK-UNC 7/16-14	M10x0.75	141	100	80	40	2.0	10	TA229744.0970
0.3858			9.800	STI 3/8-24		141	100	80	40	2.0	10	TA229744.0980
0.3898			9.900	7/16-20 UNF		141	100	80	40	2.1	10	TA229744.0990
0.3906	25/64"		9.921			141	100	80	40	2.1	10	TA229744.0992
0.3937			10.000	7/16-20 UNJF		141	100	80	40	2.1	10	TA229744.1000
0.3976			10.100			166	120	96	45	2.1	12	TA229744.1010
0.4016			10.200	7/16-28 UNEF		166	120	96	45	2.1	12	TA229744.1020
0.4035			10.250		7/16-14 UNC	166	120	96	45	2.1	12	TA229744.1025
0.4055			10.300			166	120	96	45	2.1	12	TA229744.1030
0.4063	13/32"		10.320			166	120	96	45	2.1	12	TA229744.1032
0.4075			10.350			166	120	96	45	2.1	12	TA229744.1035
0.4094			10.400			166	120	96	45	2.1	12	TA229744.1040
0.4134			10.500	M12x1.5		166	120	96	45	2.2	12	TA229744.1050
0.4154			10.550		7/16-20 UNF	166	120	96	45	2.2	12	TA229744.1055
0.4173			10.600			166	120	96	45	2.2	12	TA229744.1060
0.4213			10.700	LK-M12		166	120	96	45	2.2	12	TA229744.1070
0.4219	27/64"		10.716	1/2-13 UNC		166	120	96	45	2.2	12	TA229744.1072
0.4252			10.800	M12x1.25		166	120	96	45	2.2	12	TA229744.1080
0.4291			10.900	1/2-13 UNJC		166	120	96	45	2.3	12	TA229744.1090
0.4331			11.000	M12x1		166	120	96	45	2.3	12	TA229744.1100
0.4370			11.100	BSF 1/2-16		166	120	96	45	2.3	12	TA229744.1110



MultiDRILL™

8 x D - Coolant Fed (continued)

- Double margin design for rounder and straighter holes
- Unique TiAlN-T63 coating for heat and wear resistance
- 135° drill point angle
- Preparatory center drilling recommended with 142° NC Spot drill

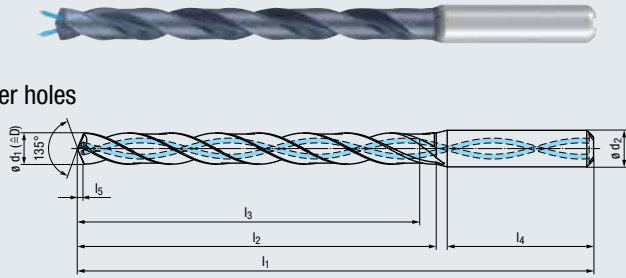

Applications - Materials

P	1.1-5.1
M	1.1-3.1
K	1.1-4.2
N	1.1-1.6, 2.1-2.8
S	1.2-1.3, 2.2-2.3
H	1.1-1.3

Product Finder / Material Descriptions (see pages 4-5)
Cutting Data (see pages 52-53)

Nominal Size ø d ₁ m7 Tolerance				Taps	Roll Form Taps	mm					EDP No. HA SHANK	
Inch	Fraction	Wire letter	mm			l ₁	l ₂	l ₃	l ₄	l ₅		ø d ₂ h6 Tol.
0.4375	7/16"		11.113	LK-UNC 1/2-13		166	120	96	45	2.3	12	TA229744.1111
0.4409			11.200			166	120	96	45	2.3	12	TA229744.1120
0.4429			11.250	M12x0.75	M12	166	120	96	45	2.3	12	TA229744.1125
0.4449			11.300			166	120	96	45	2.3	12	TA229744.1130
0.4469			11.350		M12x1.5	166	120	96	45	2.4	12	TA229744.1135
0.4488			11.400	1/4-18 NPSC		166	120	96	45	2.4	12	TA229744.1140
0.4508			11.450		M12x1.25	166	120	96	45	2.4	12	TA229744.1145
0.4528			11.500	1/2-20 UNF		166	120	96	45	2.4	12	TA229744.1150
0.4531	29/64"		11.509			166	120	96	45	2.4	12	TA229744.1151
0.4567			11.600	1/2-20 UNJF	M12x1	166	120	96	45	2.4	12	TA229744.1160
0.4606			11.700			166	120	96	45	2.4	12	TA229744.1170
0.4646			11.800	1/2-28 UNEF	1/2-13 UNC	166	120	96	45	2.4	12	TA229744.1180
0.4685			11.900			166	120	96	45	2.5	12	TA229744.1190
0.4688	15/32"		11.908			166	120	96	45	2.5	12	TA229744.1191
0.4724			12.000	M14		166	120	96	45	2.5	12	TA229744.1200
0.4783			12.150		1/2-20 UNF	186	140	112	45	2.5	14	TA229744.1215
0.4803			12.200	Tr 14x2		186	140	112	45	2.5	14	TA229744.1220
0.4844	31/64"		12.304	9/16-12 UNC		186	140	112	45	2.5	14	TA229744.1230
0.4921			12.500	M14x1.5		186	140	112	45	2.6	14	TA229744.1250
0.4941			12.550		G 1/4-19	186	140	112	45	2.6	14	TA229744.1255
0.4961			12.600			186	140	112	45	2.6	14	TA229744.1260
0.5000	1/2"		12.700	LK-UNC 9/16-12		186	140	112	45	2.6	14	TA229744.1270
0.5039			12.800	M14x1.25		186	140	112	45	2.7	14	TA229744.1280
0.5118			13.000	9/16-18 UNJF		186	140	112	45	2.7	14	TA229744.1300
0.5157			13.100	STI-UNF 1/2-20	M14	186	140	112	45	2.7	14	TA229744.1310
0.5236			13.300	9/16-24 UNEF	9/16-12 UNC	186	140	112	45	2.8	14	TA229744.1330
0.5256			13.350		M14x1.5	186	140	112	45	2.8	14	TA229744.1335
0.5295			13.450		M14x1.25	186	140	112	45	2.8	14	TA229744.1345
0.5313	17/32"		13.495	5/8-11 UNC		186	140	112	45	2.8	14	TA229744.1349
0.5315			13.500			186	140	112	45	2.8	14	TA229744.1350
0.5354			13.600			186	140	112	45	2.8	14	TA229744.1360
0.5374			13.650	5/8-11 UNJC	9/16-18 UNF	186	140	112	45	2.8	14	TA229744.1365
0.5394			13.700			186	140	112	45	2.8	14	TA229744.1370
0.5433			13.800			186	140	112	45	2.8	14	TA229744.1380
0.5469	35/64"		13.891			186	140	112	45	2.8	14	TA229744.1389
0.5512			14.000	M16 / M15x1		186	140	112	45	2.9	14	TA229744.1400
0.5551			14.100			209	160	128	45	2.9	16	TA229744.1410
0.5625	9/16"		14.290			209	160	128	45	2.9	16	TA229744.1429
0.5709			14.500	5/8-18 UNF		209	160	128	48	3.0	16	TA229744.1450
0.5748			14.600	5/8-18 UNJF	M15x1	209	160	128	48	3.0	16	TA229744.1460
0.5781	37/64"		14.684	3/8-18 NPSC		209	160	128	48	3.0	16	TA229744.1468
0.5827			14.800		5/8-11 UNC	209	160	128	48	3.0	16	TA229744.1480
0.5906			15.000	M16x1		209	160	128	48	3.1	16	TA229744.1500
0.5938	19/32"		15.083			209	160	128	48	3.1	16	TA229744.1508
0.5945			15.100		M16	209	160	128	48	3.1	16	TA229744.1510
0.6043			15.350			209	160	128	48	3.1	16	TA229744.1535
0.6102			15.500	M18		209	160	128	48	3.2	16	TA229744.1550
0.6142			15.600		M16x1	209	160	128	48	3.2	16	TA229744.1560
0.6250	5/8"		15.875			209	160	128	48	3.2	16	TA229744.1588
0.6299			16.000	M18x2		209	160	128	48	3.3	16	TA229744.1600



MultiDRILL™

6 x D Micro - Coolant Fed

- Advanced flute profile designed to enhance chip evacuation of varying materials
- Radius cutting edge for high shearing action
- Specialized point geometry generates short chips and guarantees optimum performance
- ALCR-99 coating for heat and wear resistance
- 130° drill point angle

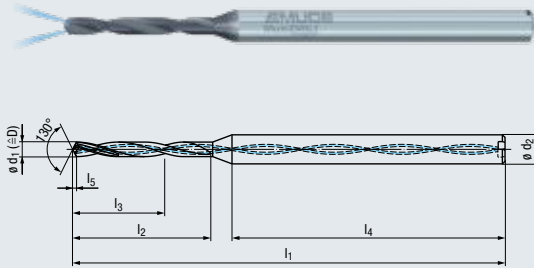

Applications - Materials

P	1.1-5.1
M	1.1-4.1
K	1.1-3.2
N	1.1-1.6, 2.1-2.3
S	1.1-1.3, 2.2-2.3
H	1.1-1.2

Product Finder / Range of Applications and Material Descriptions (see pages 4-5)

Cutting Data (see page 61)

Coolant Pressure / Flow Rate Recommendations (see page 66)

Nominal Size ø d ₁ k5 Tolerance		Taps	Roll Form Taps	mm					ø d ₂ h6 Tol.	EDP No. HA SHANK
Inch	mm			l ₁	l ₂	l ₃	l ₄	l ₅		
0.0394	1.00	M1.2x0.2	M1.1	50	9.30	6.00	38.00	0.20	3	TE219744.0100
0.0413	1.05			50	9.80	6.30	37.50	0.20	3	TE219744.0105
0.0433	1.10	M1.4	M1.2	50	10.25	6.60	37.10	0.20	3	TE219744.0110
0.0453	1.15			50	10.70	6.90	36.70	0.20	3	TE219744.0115
0.0472	1.20	M1.4x0.2		50	11.20	7.20	36.30	0.20	3	TE219744.0120
0.0492	1.25	M1.6 / #0-80		50	11.65	7.50	35.90	0.20	3	TE219744.0125
0.0512	1.30	MJ1.6x0.35		52	12.10	7.80	37.60	0.25	3	TE219744.0130
0.0531	1.35	M1.7		52	12.60	8.10	37.10	0.25	3	TE219744.0135
0.0551	1.40	M1.6x0.2	#0-80	52	13.05	8.40	36.80	0.25	3	TE219744.0140
0.0571	1.45	M1.8		52	13.50	8.70	36.40	0.25	3	TE219744.0145
0.0579	1.47		M1.6	52	13.65	8.82	36.20	0.25	3	TE219744.0147
0.0591	1.50			52	13.95	9.00	36.00	0.25	3	TE219744.0150
0.0610	1.55			55	14.45	9.30	38.50	0.30	3	TE219744.0155
0.0630	1.60	M2 / M1.8x0.2		55	14.90	9.60	38.20	0.30	3	TE219744.0160
0.0650	1.65			55	15.35	9.90	37.80	0.30	3	TE219744.0165
0.0669	1.70		#1-64 / #1-72	55	15.85	10.20	37.40	0.30	3	TE219744.0170
0.0689	1.75	M2.2 / M2x0.25		55	16.30	10.50	37.00	0.30	3	TE219744.0175
0.0709	1.80			57	16.75	10.80	38.60	0.30	3	TE219744.0180
0.0728	1.85	#2-56 / #2-64	M2	57	17.25	11.10	38.20	0.35	3	TE219744.0185
0.0748	1.90	M2.3	M2x0.25	57	17.70	11.40	37.80	0.35	3	TE219744.0190
0.0768	1.95	M2.2x0.25 / M2.3x0.35		57	18.15	11.70	37.40	0.35	3	TE219744.0195
0.0787	2.00		#2-56	57	18.60	12.00	35.60	0.35	4	TE219744.0200
0.0799	2.03		M2.2 / #2-64	57	18.87	12.18	35.40	0.35	4	TE219744.0203
0.0807	2.05	M2.5 / M2.3x0.25		60	19.10	12.30	38.20	0.35	4	TE219744.0205
0.0827	2.10	MJ2.5x0.45 / #3-48	M2.2x0.25	60	19.55	12.60	37.80	0.40	4	TE219744.0210
0.0846	2.15	M2.6 / M2.5x0.35 / #3-56	M2.3	60	20.00	12.90	37.40	0.40	4	TE219744.0215
0.0866	2.20		M2.3x0.25	60	20.50	13.20	37.00	0.40	4	TE219744.0220
0.0886	2.25			60	20.95	13.50	36.60	0.40	4	TE219744.0225
0.0906	2.30		#3-48	62	21.40	13.80	38.30	0.40	4	TE219744.0230
0.0917	2.33		M2.5 / #3-56	62	21.65	13.98	38.00	0.40	4	TE219744.0233
0.0925	2.35			62	21.90	14.10	37.80	0.40	4	TE219744.0235
0.0945	2.40	#4-48	M2.5x0.25	62	22.35	14.40	37.50	0.45	4	TE219744.0240
0.0965	2.45			62	22.80	14.70	37.10	0.45	4	TE219744.0245
0.0984	2.50	M3	M2.6x0.25	62	23.25	15.00	36.70	0.45	4	TE219744.0250
0.1003	2.55		#4-40	65	23.75	15.30	39.20	0.45	4	TE219744.0255
0.1024	2.60	MJ3x0.5		65	24.20	15.60	38.90	0.45	4	TE219744.0260
0.1043	2.65	M3x0.35 / #5-40	#4-48	65	24.65	15.90	38.50	0.45	4	TE219744.0265
0.1063	2.70	#5-44		65	25.15	16.20	38.10	0.50	4	TE219744.0270
0.1083	2.75			65	25.60	16.50	37.70	0.50	4	TE219744.0275
0.1102	2.80	#6-32	M3	67	26.05	16.80	39.30	0.50	4	TE219744.0280
0.1122	2.85			67	26.55	17.10	38.90	0.50	4	TE219744.0285
0.1142	2.90	M3.5	M3x0.25 / #5-40	67	27.00	17.40	38.50	0.50	4	TE219744.0290
0.1160	2.95		#5-44	67	27.45	17.70	38.10	0.55	4	TE219744.0295

SteelDrill

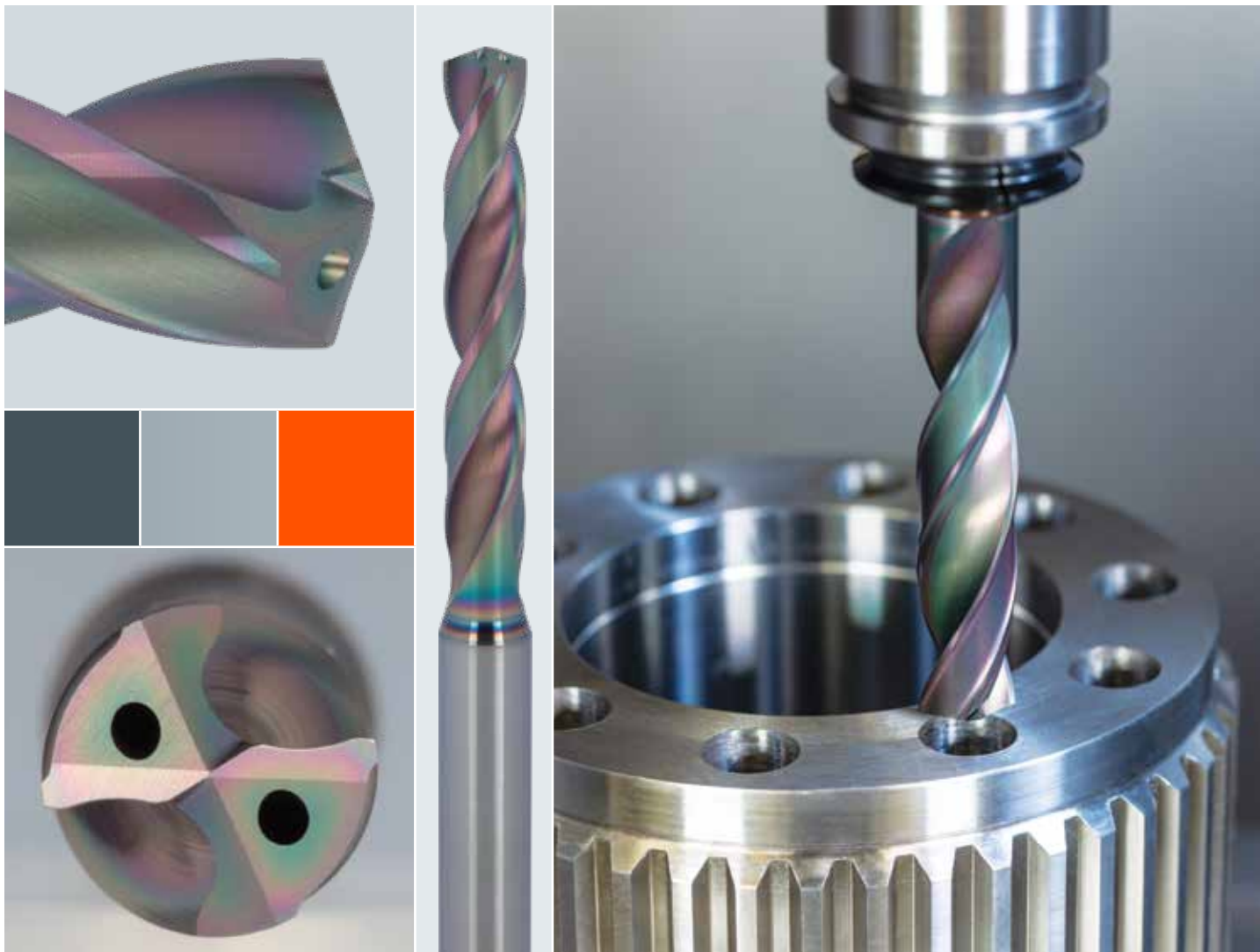

High-Performance SteelDrill

The EMUGE SteelDrill line is ideal for machining steel and cast materials and also for achieving good results in hard and non-ferrous materials. Drills are available in diameters from .1181 to .7500 (3.00 to 19.05 mm) and available in 3 x D, 5 x D and 8 x D sizes.

- Double-margin design for maximum stabilization and rounder, more accurate hole quality
- Internal cooling channels
- High-performance coating for high process reliability

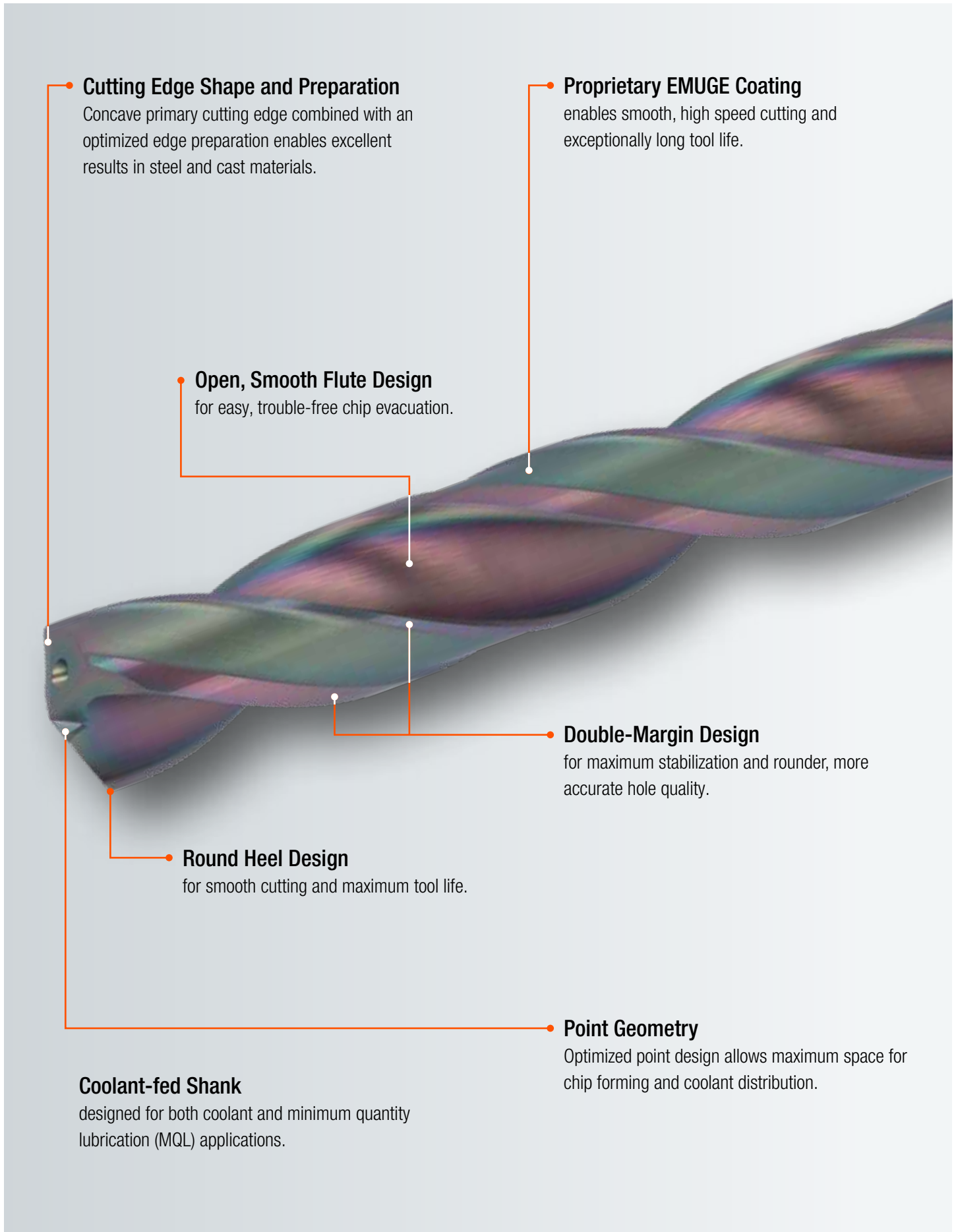

● **Cutting Edge Shape and Preparation**

Concave primary cutting edge combined with an optimized edge preparation enables excellent results in steel and cast materials.

● **Proprietary EMUGE Coating**

enables smooth, high speed cutting and exceptionally long tool life.

● **Open, Smooth Flute Design**

for easy, trouble-free chip evacuation.

● **Double-Margin Design**

for maximum stabilization and rounder, more accurate hole quality.

● **Round Heel Design**

for smooth cutting and maximum tool life.

● **Point Geometry**

Optimized point design allows maximum space for chip forming and coolant distribution.

Coolant-fed Shank

designed for both coolant and minimum quantity lubrication (MQL) applications.



3 x D - Axial Coolant

- High performance carbide drill for reduced cycle times
- Sub-micro grain carbide
- ALTIN-112 Coating
- Double-margin flute design
- 2 Flutes with 30° Helix angle
- 140° drill point angle

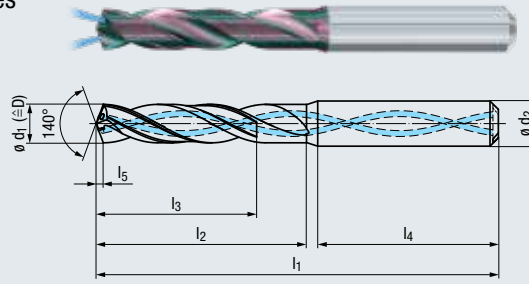

Applications - Materials

P	1.1-5.1
K	1.1-4.2
S	1.2-1.3, 2.2-2.3
H	1.1-1.3

Product Finder / Range of Applications and Material Descriptions (see pages 4-5)
Cutting Data (see pages 54-55)

Nominal Size ø d ₁ m7 Tolerance				Taps	Roll Form Taps	mm					EDP No. HA SHANK	
Inch	Fraction	Wire letter	mm			l ₁	l ₂	l ₃	l ₄	l ₅	ø d ₂ h6 Tol.	
0.1181			3.000	#6-40 UNF		62	20	14	36	0.6	6	TA201544.0300
0.1220			3.100	STI-#4-40		62	20	14	36	0.6	6	TA201544.0310
0.1240			3.150	M3.5x0.35	#6-32 UNC	62	20	14	36	0.6	6	TA201544.0315
0.1250	1/8"		3.175			62	20	14	36	0.6	6	TA201544.0318
0.1260			3.200	BSW ⁵ /32-32	#6-40 UNF	62	20	14	36	0.6	6	TA201544.0320
0.1268			3.220			62	20	14	36	0.6	6	TA201544.0322
0.1280			3.250		M3.5	62	20	14	36	0.6	6	TA201544.0325
0.1299			3.300	M4		62	20	14	36	0.7	6	TA201544.0330
0.1319			3.350			62	20	14	36	0.7	6	TA201544.0335
0.1331			3.380		M3.5x0.35	62	20	14	36	0.7	6	TA201544.0338
0.1339			3.400	MJ4x0.7		62	20	14	36	0.7	6	TA201544.0340
0.1378			3.500	#8-32 UNC		62	20	14	36	0.7	6	TA201544.0350
0.1406	9/64	#28	3.571			62	20	14	36	0.7	6	TA201544.0357
0.1417			3.600	#8-36 UNF		62	20	14	36	0.7	6	TA201544.0360
0.1437			3.650			62	20	14	36	0.7	6	TA201544.0365
0.1457			3.700	M4.5	M4	62	20	14	36	0.7	6	TA201544.0370
0.1496		#25	3.800	STI-#6-32	#8-32 UNC	66	24	17	36	0.7	6	TA201544.0380
0.1516			3.850		#8-36 UNF	66	24	17	36	0.8	6	TA201544.0385
0.1528			3.880			66	24	17	36	0.8	6	TA201544.0388
0.1535			3.900	#10-24 UNC		66	24	17	36	0.8	6	TA201544.0390
0.1563	5/32"		3.970			66	24	17	36	0.8	6	TA201544.0397
0.1575			4.000	M4.5x0.5		66	24	17	36	0.8	6	TA201544.0400
0.1590		#21	4.038			66	24	17	36	0.8	6	TA201544.0404
0.1614			4.100	#10-32 UNF		66	24	17	36	0.8	6	TA201544.0410
0.1634			4.150			66	24	17	36	0.8	6	TA201544.0415
0.1654			4.200	M5, STI-M4	M4.5	66	24	17	36	0.8	6	TA201544.0420
0.1693		#18	4.300	MJ5x0.8		66	24	17	36	0.8	6	TA201544.0430
0.1713			4.350		#10-24 UNC	66	24	17	36	0.8	6	TA201544.0435
0.1719	11/64"		4.366			66	24	17	36	0.8	6	TA201544.0437
0.1732			4.400	M5x0.75		66	24	17	36	0.9	6	TA201544.0440
0.1752			4.450		#10-32 UNF	66	24	17	36	0.9	6	TA201544.0445
0.1772			4.500	#12-24 UNC		66	24	17	36	0.9	6	TA201544.0450
0.1811			4.600	#12-28 UNF		66	24	17	36	0.9	6	TA201544.0460
0.1831			4.650	#12-24 UNJC	M5	66	24	17	36	0.9	6	TA201544.0465
0.1850		#13	4.700	LK-UNC #12-24		66	24	17	36	0.9	6	TA201544.0470
0.1875	3/16"		4.763	#12-28 UNJF		66	28	17	36	0.9	6	TA201544.0476
0.1890		#12	4.800	#12-32 UNEF	M5x0.5, STI-M5	66	28	20	36	0.9	6	TA201544.0480
0.1929			4.900			66	28	20	36	0.9	6	TA201544.0490
0.1969			5.000	M6	#12-24 UNC	66	28	20	36	1.0	6	TA201544.0500
0.2008			5.100	MJ6x1	#12-28 UNF	66	28	20	36	1.0	6	TA201544.0510
0.2010		#7	5.106			66	28	20	36	1.0	6	TA201544.0511
0.2031	13/64"		5.159			66	28	20	36	1.0	6	TA201544.0516
0.2047			5.200	1/4-20 UNC		66	28	20	36	1.0	6	TA201544.0520
0.2087			5.300	1/4-20 UNJC		66	28	20	36	1.0	6	TA201544.0530
0.2126			5.400			66	28	20	36	1.0	6	TA201544.0540
0.2130		#3	5.410			66	28	20	36	1.0	6	TA201544.0541
0.2165			5.500	1/4-28 UNF		66	28	20	36	1.1	6	TA201544.0550
0.2187	7/32"		5.556	1/4-28 UNJF		66	28	20	36	1.1	6	TA201544.0556
0.2205			5.600	1/4-32 UNEF	M6	66	28	20	36	1.1	6	TA201544.0560
0.2244			5.700			66	28	20	36	1.1	6	TA201544.0570
0.2264			5.750		1/4-20 UNC	66	28	20	36	1.1	6	TA201544.0575
0.2283			5.800		M6x0.5	66	28	20	36	1.1	6	TA201544.0580
0.2323			5.900			66	28	20	36	1.1	6	TA201544.0590
0.2344	15/64"		5.954		1/4-28 UNF	66	28	20	36	1.1	6	TA201544.0595
0.2362			6.000	M7, Rd 8x1/10		66	28	20	36	1.1	6	TA201544.0600
0.2402			6.100	MJ7x1		79	34	24	36	1.2	8	TA201544.0610
0.2441			6.200	M7x0.75		79	34	24	36	1.2	8	TA201544.0620
0.2480			6.300	M7x0.5, STI-M6		79	34	24	36	1.2	8	TA201544.0630
0.2500	1/4	E	6.350	1/16-27 NPSF		79	34	24	36	1.2	8	TA201544.0635
0.2520			6.400			79	34	24	36	1.2	8	TA201544.0640
0.2559			6.500	BSW ⁵ /16-18		79	34	24	36	1.2	8	TA201544.0650
0.2570		F	6.528			79	34	24	36	1.3	8	TA201544.0653
0.2598			6.600	5/16-18 UNC	M7	79	34	24	36	1.3	8	TA201544.0660
0.2638			6.700	5/16-18 UNJC	M7x0.75	79	34	24	36	1.3	8	TA201544.0670



3 x D - Axial Coolant (continued)

- High performance carbide drill for reduced cycle times
- Sub-micro grain carbide
- ALTiN-112 Coating
- Double-margin flute design
- 2 Flutes with 30° Helix angle
- 140° drill point angle

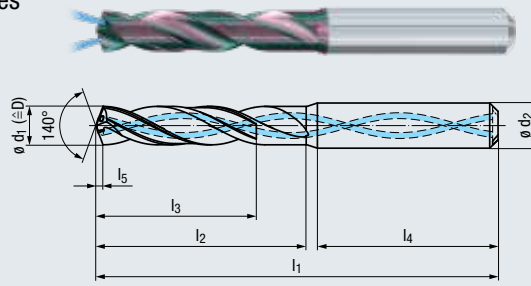

Applications - Materials

P	1.1-5.1
K	1.1-4.2
S	1.2-1.3, 2.2-2.3
H	1.1-1.3

Product Finder / Range of Applications and Material Descriptions (see pages 4-5)
Cutting Data (see pages 54-55)

Nominal Size ø d ₁ m7 Tolerance				Taps	Roll Form Taps	mm					EDP No. HA SHANK	
Inch	Fraction	Wire letter	mm			l ₁	l ₂	l ₃	l ₄	l ₅	ø d ₂ h6 Tol.	
0.2656	17/64"		6.746			79	34	24	36	1.3	8	TA201544.0675
0.2677			6.800	M8, G 1/16		79	34	24	36	1.3	8	TA201544.0680
0.2717			6.900	5/16-24 UNF		79	34	24	36	1.3	8	TA201544.0690
0.2756			7.000	5/16-24 UNJF		79	34	24	36	1.3	8	TA201544.0700
0.2795			7.100	MJ8x1		79	41	29	36	1.3	8	TA201544.0710
0.2813	9/32"	K	7.145			79	41	29	36	1.3	8	TA201544.0715
0.2835			7.200	5/16-32 UNEF		79	41	29	36	1.4	8	TA201544.0720
0.2854			7.250		5/16-18 UNC	79	41	29	36	1.4	8	TA201544.0725
0.2874			7.300			79	41	29	36	1.4	8	TA201544.0730
0.2913			7.400			79	41	29	36	1.4	8	TA201544.0740
0.2933			7.450		5/16-24 UNF, M8	79	41	29	36	1.4	8	TA201544.0745
0.2953			7.500	M8x0.5		79	41	29	36	1.4	8	TA201544.0750
0.2969	19/64"		7.541			79	41	29	36	1.4	8	TA201544.0754
0.2992			7.600	Tr9x1.5	M8x1, STI-M8	79	41	29	36	1.4	8	TA201544.0760
0.3031			7.700		M8x0.75	79	41	29	36	1.5	8	TA201544.0770
0.3071			7.800	M9		79	41	29	36	1.5	8	TA201544.0780
0.3110			7.900	BSW 3/8-16		79	41	29	36	1.5	8	TA201544.0790
0.3125	5/16"		7.938			79	41	29	36	1.5	8	TA201544.0794
0.3150			8.000	3/8-16 UNC		79	41	29	36	1.5	8	TA201544.0800
0.3189			8.100	3/8-16 UNJC		89	47	35	40	1.5	10	TA201544.0810
0.3228			8.200	M9x0.75		89	47	35	40	1.5	10	TA201544.0820
0.3268			8.300	LK-UNC 3/8-16		89	47	35	40	1.6	10	TA201544.0830
0.3281	21/64"		8.334			89	47	35	40	1.6	10	TA201544.0833
0.3307			8.400	STI-5/16-18		89	47	35	40	1.6	10	TA201544.0840
0.3327			8.450			89	47	35	40	1.6	10	TA201544.0845
0.3346			8.500	3/8-24 UNF, M10		89	47	35	40	1.6	10	TA201544.0850
0.3386			8.600	3/8-24 UNJF	M9x1	89	47	35	40	1.6	10	TA201544.0860
0.3425			8.700	3/8-32 UNEF	M9x0.75	89	47	35	40	1.6	10	TA201544.0870
0.3438	11/32"		8.733	1/8-27 NPSC		89	47	35	40	1.6	10	TA201544.0873
0.3465			8.800	M10x1.25	3/8-16 UNC	89	47	35	40	1.7	10	TA201544.0880
0.3504			8.900	MJ10x1.25		89	47	35	40	1.7	10	TA201544.0890
0.3543			9.000	M10x1		89	47	35	40	1.7	10	TA201544.0900
0.3563			9.050		3/8-24 UNF	89	47	35	40	1.7	10	TA201544.0905
0.3583			9.100	1/8-27 NPSM		89	47	35	40	1.7	10	TA201544.0910
0.3594	23/64"		9.129			89	47	35	40	1.7	10	TA201544.0913
0.3622			9.200	M10x0.75		89	47	35	40	1.7	10	TA201544.0920
0.3661			9.300			89	47	35	40	1.7	10	TA201544.0930
0.3681			9.350		M10	89	47	35	40	1.8	10	TA201544.0935
0.3701			9.400	7/16-14 UNC		89	47	35	40	1.8	10	TA201544.0940
0.3720			9.450			89	47	35	40	1.8	10	TA201544.0945
0.3740			9.500	7/16-14 UNJC	STI-M10	89	47	35	40	1.8	10	TA201544.0950
0.3750	3/8"		9.525			89	47	35	40	1.8	10	TA201544.0953
0.3780			9.600		M10x1	89	47	35	40	1.8	10	TA201544.0960
0.3819			9.700	LK-UNC 7/16-14	M10x0.75	89	47	35	40	1.8	10	TA201544.0970
0.3858			9.800	STI-3/8-24		89	47	35	40	1.8	10	TA201544.0980
0.3898			9.900	7/16-20 UNF		89	47	35	40	1.9	10	TA201544.0990
0.3906	25/64"		9.921			89	47	35	40	1.9	10	TA201544.0992
0.3937			10.000	7/16-20 UNJF		89	47	35	40	1.9	10	TA201544.1000
0.3976			10.100			102	55	40	45	1.9	12	TA201544.1010
0.4016			10.200	7/16-28 UNEF		102	55	40	45	1.9	12	TA201544.1020
0.4035			10.250		7/16-14 UNC	102	55	40	45	1.9	12	TA201544.1025
0.4055			10.300			102	55	40	45	1.9	12	TA201544.1030
0.4063	13/32"		10.320			102	55	40	45	1.9	12	TA201544.1032
0.4075			10.350			102	55	40	45	1.9	12	TA201544.1035
0.4094			10.400			102	55	40	45	1.9	12	TA201544.1040
0.4134			10.500	M12x1.5		102	55	40	45	2.0	12	TA201544.1050
0.4154			10.550		7/16-20 UNF	102	55	40	45	2.0	12	TA201544.1055
0.4173			10.600			102	55	40	45	2.0	12	TA201544.1060
0.4213			10.700	LK-M12		102	55	40	45	2.0	12	TA201544.1070
0.4219	27/64"		10.716	1/2-13 UNC		102	55	40	45	2.0	12	TA201544.1072
0.4252			10.800	M12x1.25		102	55	40	45	2.0	12	TA201544.1080
0.4291			10.900	1/2-13 UNJC		102	55	40	45	2.0	12	TA201544.1090
0.4331			11.000	M12x1		102	55	40	45	2.1	12	TA201544.1100
0.4370			11.100	BSF 1/2-16		102	55	40	45	2.1	12	TA201544.1110



3 x D - Axial Coolant (continued)

- High performance carbide drill for reduced cycle times
- Sub-micro grain carbide
- ALTIN-112 Coating
- Double-margin flute design
- 2 Flutes with 30° Helix angle
- 140° drill point angle

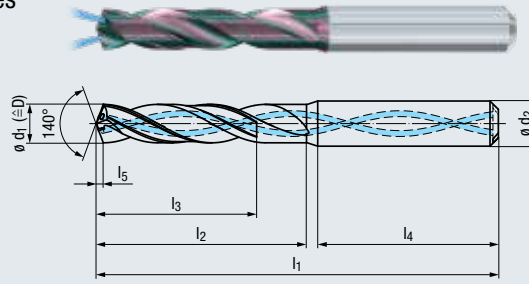

Applications - Materials

P	1.1-5.1
K	1.1-4.2
S	1.2-1.3, 2.2-2.3
H	1.1-1.3

Product Finder / Range of Applications and Material Descriptions (see pages 4-5)
Cutting Data (see pages 54-55)

Nominal Size ϕd_1 m7 Tolerance				Taps	Roll Form Taps	mm					EDP No. HA SHANK	
Inch	Fraction	Wire letter	mm			l_1	l_2	l_3	l_4	l_5	ϕd_2 h6 Tol.	
0.4375	7/16"		11.113	LK-UNC 1/2-13		102	55	40	45	2.1	12	TA201544.1111
0.4409			11.200			102	55	40	45	2.1	12	TA201544.1120
0.4429			11.250	M12x0.75	M12	102	55	40	45	2.1	12	TA201544.1125
0.4449			11.300			102	55	40	45	2.1	12	TA201544.1130
0.4469			11.350		M12x1.5	102	55	40	45	2.1	12	TA201544.1135
0.4488			11.400	1/4-18 NPSC		102	55	40	45	2.1	12	TA201544.1140
0.4508			11.450		M12x1.25	102	55	40	45	2.1	12	TA201544.1145
0.4528			11.500	1/2-20 UNF		102	55	40	45	2.1	12	TA201544.1150
0.4531	29/64"		11.509			102	55	40	45	2.1	12	TA201544.1151
0.4567			11.600	1/2-20 UNJF	M12x1	102	55	40	45	2.2	12	TA201544.1160
0.4606			11.700			102	55	40	45	2.2	12	TA201544.1170
0.4646			11.800	1/2-28 UNEF	1/2-13 UNC	102	55	40	45	2.2	12	TA201544.1180
0.4685			11.900			102	55	40	45	2.2	12	TA201544.1190
0.4688	15/32"		11.908			102	55	40	45	2.2	12	TA201544.1191
0.4724			12.000	M14		107	55	40	45	2.2	12	TA201544.1200
0.4783			12.150		1/2-20 UNF	107	60	43	45	2.2	14	TA201544.1215
0.4803			12.200	Tr 14x2		107	60	43	45	2.3	14	TA201544.1220
0.4844	31/64"		12.304	9/16-12 UNC		107	60	43	45	2.3	14	TA201544.1230
0.4921			12.500	M14x1.5		107	60	43	45	2.3	14	TA201544.1250
0.4941			12.550		G 1/4-19	107	60	43	45	2.3	14	TA201544.1255
0.4961			12.600			107	60	43	45	2.3	14	TA201544.1260
0.5000	1/2"		12.700	LK-UNC 9/16-12		107	60	43	45	2.4	14	TA201544.1270
0.5039			12.800	M14x1.25		107	60	43	45	2.4	14	TA201544.1280
0.5118			13.000	9/16-18 UNJF		107	60	43	45	2.4	14	TA201544.1300
0.5157			13.100	STI-1/2-20	M14	107	60	43	45	2.4	14	TA201544.1310
0.5236			13.300	9/16-24 UNEF	9/16-12 UNC	107	60	43	45	2.5	14	TA201544.1330
0.5256			13.350		M14x1.5	107	60	43	45	2.5	14	TA201544.1335
0.5295			13.450		M14x1.25	107	60	43	45	2.5	14	TA201544.1345
0.5313	17/32"		13.495	5/8-11 UNC		107	60	43	45	2.5	14	TA201544.1349
0.5315			13.500			107	60	43	45	2.5	14	TA201544.1350
0.5354			13.600			107	60	43	45	2.5	14	TA201544.1360
0.5374			13.650	5/8-11 UNJC	9/16-18 UNF	107	60	43	45	2.5	14	TA201544.1365
0.5394			13.700			107	60	43	45	2.5	14	TA201544.1370
0.5433			13.800			107	60	43	45	2.6	14	TA201544.1380
0.5469	35/64"		13.891			107	60	43	45	2.6	14	TA201544.1389
0.5512			14.000	M16, M15x1		107	60	43	45	2.6	14	TA201544.1400
0.5551			14.100			115	65	45	48	2.6	16	TA201544.1410
0.5625	9/16"		14.290			115	65	45	48	2.6	16	TA201544.1429
0.5709			14.500	5/8-18 UNF		115	65	45	48	2.7	16	TA201544.1450
0.5748			14.600	5/8-18 UNJF	M15x1	115	65	45	48	2.7	16	TA201544.1460
0.5781	37/64"		14.684	3/8-18 NPSC		115	65	45	48	2.7	16	TA201544.1468
0.5827			14.800		5/8-11 UNC	115	65	45	48	2.7	16	TA201544.1480
0.5906			15.000	M16x1		115	65	45	48	2.8	16	TA201544.1500
0.5938	19/32"		15.083			115	65	45	48	2.8	16	TA201544.1508
0.5945			15.100		M16	115	65	45	48	2.8	16	TA201544.1510
0.6043			15.350			115	65	45	48	2.8	16	TA201544.1535
0.6102			15.500	M18		115	65	45	48	2.9	16	TA201544.1550
0.6142			15.600		M16x1	115	65	45	48	2.9	16	TA201544.1560
0.6250	5/8"		15.875			115	65	45	48	2.9	16	TA201544.1588
0.6299			16.000	M18x2		115	65	45	48	3.0	16	TA201544.1600
0.6406	41/64"		16.272			123	73	51	48	3.0	18	TA201544.1627
0.6496			16.500	STI-5/8-11		123	73	51	48	3.1	18	TA201544.1650
0.6563	21/32"		16.669	3/4-10 UNC		123	73	51	48	3.1	18	TA201544.1667
0.6693			17.000	M18x1		123	73	51	48	3.1	18	TA201544.1700
0.6875	11/16"		17.463			123	73	51	48	3.1	18	TA201544.1746
0.6890			17.500	3/4-16 UNF, M20		123	73	51	48	3.2	18	TA201544.1750
0.7087			18.000	M20x2, LK-M16		123	73	51	48	3.3	18	TA201544.1800
0.7500	3/4"		19.050			131	79	55	50	3.6	20	TA201544.1905



5 x D - Axial Coolant

- High performance carbide drill for reduced cycle times
- Sub-micro grain carbide
- ALTiN-112 Coating
- Double-margin flute design
- 2 Flutes with 30° Helix angle
- 140° drill point angle

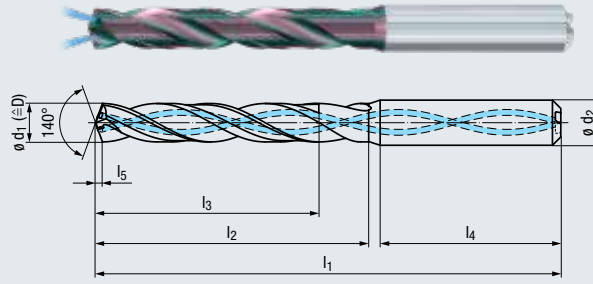

Applications - Materials

P	1.1-5.1
K	1.1-4.2
S	1.2-1.3, 2.2-2.3
H	1.1-1.3

Product Finder / Range of Applications and Material Descriptions (see pages 4-5)
Cutting Data (see pages 54-55)

Nominal Size ø d ₁ m7 Tolerance				Taps	Roll Form Taps	mm					EDP No. HA SHANK	
Inch	Fraction	Wire letter	mm			l ₁	l ₂	l ₃	l ₄	l ₅	ø d ₂ h6 Tol.	
0.1181			3.000	#6-40 UNF		66	28	23	36	0.6	6	TA211544.0300
0.1220			3.100	STI-#4-40		66	28	23	36	0.6	6	TA211544.0310
0.1240			3.150	M3.5x0.35	#6-32 UNC	66	28	23	36	0.6	6	TA211544.0315
0.1250	1/8"		3.175			66	28	23	36	0.6	6	TA211544.0318
0.1260			3.200	BSW ⁵ /32-32	#6-40 UNF	66	28	23	36	0.6	6	TA211544.0320
0.1268			3.220			66	28	23	36	0.6	6	TA211544.0322
0.1280			3.250		M3.5	66	28	23	36	0.6	6	TA211544.0325
0.1299			3.300	M4		66	28	23	36	0.7	6	TA211544.0330
0.1319			3.350			66	28	23	36	0.7	6	TA211544.0335
0.1331			3.380		M3.5x0.35	66	28	23	36	0.7	6	TA211544.0338
0.1339			3.400	MJ4x0.7		66	28	23	36	0.7	6	TA211544.0340
0.1378			3.500	#8-32 UNC		66	28	23	36	0.7	6	TA211544.0350
0.1406	9/64	#28	3.571			66	28	23	36	0.7	6	TA211544.0357
0.1417			3.600	#8-36 UNJF		66	28	23	36	0.7	6	TA211544.0360
0.1437			3.650			66	28	23	36	0.7	6	TA211544.0365
0.1457			3.700	M4.5	M4	66	28	23	36	0.7	6	TA211544.0370
0.1496		#25	3.800	STI-#6-32	#8-32 UNC	74	36	29	36	0.7	6	TA211544.0380
0.1516			3.850		#8-36 UNF	74	36	29	36	0.8	6	TA211544.0385
0.1528			3.880			74	36	29	36	0.8	6	TA211544.0388
0.1535			3.900	#10-24 UNC		74	36	29	36	0.8	6	TA211544.0390
0.1563	5/32"		3.970			74	36	29	36	0.8	6	TA211544.0397
0.1575			4.000	M4.5x0.5		74	36	29	36	0.8	6	TA211544.0400
0.1590		#21	4.038			74	36	29	36	0.8	6	TA211544.0404
0.1614			4.100	#10-32 UNF		74	36	29	36	0.8	6	TA211544.0410
0.1634			4.150			74	36	29	36	0.8	6	TA211544.0415
0.1654			4.200	M5, STI-M4	M4.5	74	36	29	36	0.8	6	TA211544.0420
0.1693		#18	4.300	MJ5x0.8		74	36	29	36	0.8	6	TA211544.0430
0.1713			4.350		#10-24 UNC	74	36	29	36	0.8	6	TA211544.0435
0.1719	11/64"		4.366			74	36	29	36	0.9	6	TA211544.0437
0.1732			4.400	M5x0.75		74	36	29	36	0.9	6	TA211544.0440
0.1752			4.450		#10-32 UNF	74	36	29	36	0.9	6	TA211544.0445
0.1772			4.500	#12-24 UNC		74	36	29	36	0.9	6	TA211544.0450
0.1811			4.600	#12-28 UNF		74	36	29	36	0.9	6	TA211544.0460
0.1831			4.650	#12-24 UNJC	M5	74	36	29	36	0.9	6	TA211544.0465
0.1850		#13	4.700	LK-UNC#12-24		74	36	29	36	0.9	6	TA211544.0470
0.1875	3/16"		4.763	#12-28 UNJF		82	44	35	36	0.9	6	TA211544.0476
0.1890		#12	4.800	#12-32 UNEF	M5x0.5, STI-M5	82	44	35	36	0.9	6	TA211544.0480
0.1929			4.900			82	44	35	36	0.9	6	TA211544.0490
0.1969			5.000	M6	#12-24 UNC	82	44	35	36	1.0	6	TA211544.0500
0.2008			5.100	MJ6x1	#12-28 UNF	82	44	35	36	1.0	6	TA211544.0510
0.2010		#7	5.106			82	44	35	36	1.0	6	TA211544.0511
0.2031	13/64"		5.159			82	44	35	36	1.0	6	TA211544.0516
0.2047			5.200	1/4-20 UNC		82	44	35	36	1.0	6	TA211544.0520
0.2087			5.300	1/4-20 UNJC		82	44	35	36	1.0	6	TA211544.0530
0.2126			5.400			82	44	35	36	1.0	6	TA211544.0540
0.2130		#3	5.410			82	44	35	36	1.0	6	TA211544.0541
0.2165			5.500	1/4-28 UNF		82	44	35	36	1.1	6	TA211544.0550
0.2187	7/32"		5.556	1/4-28 UNJF		82	44	35	36	1.1	6	TA211544.0556
0.2205			5.600	1/4-32 UNEF	M6	82	44	35	36	1.1	6	TA211544.0560
0.2244			5.700			82	44	35	36	1.1	6	TA211544.0570
0.2264			5.750		1/4-20 UNC	82	44	35	36	1.1	6	TA211544.0575
0.2283			5.800		M6x0.5	82	44	35	36	1.1	6	TA211544.0580
0.2323			5.900			82	44	35	36	1.1	6	TA211544.0590
0.2344	15/64"		5.954		1/4-28 UNF	82	44	35	36	1.1	6	TA211544.0595
0.2362			6.000	M7, Rd 8x1/10		82	44	35	36	1.1	6	TA211544.0600
0.2402			6.100	MJ7x1		91	53	43	36	1.2	8	TA211544.0610
0.2441			6.200	M7x0.75		91	53	43	36	1.2	8	TA211544.0620
0.2480			6.300	M7x0.5, STI-M6		91	53	43	36	1.2	8	TA211544.0630
0.2500	1/4"	E	6.350	1/16-27 NPSF		91	53	43	36	1.2	8	TA211544.0635
0.2520			6.400			91	53	43	36	1.2	8	TA211544.0640
0.2559			6.500	BSW ⁵ /16-18		91	53	43	36	1.2	8	TA211544.0650
0.2570		F	6.528			91	53	43	36	1.2	8	TA211544.0653
0.2598			6.600	5/16-18 UNC	M7	91	53	43	36	1.3	8	TA211544.0660
0.2638			6.700	5/16-18 UNJC	M7x0.75	91	53	43	36	1.3	8	TA211544.0670



5 x D - Axial Coolant (continued)

- High performance carbide drill for reduced cycle times
- Sub-micro grain carbide
- ALTiN-112 Coating
- Double-margin flute design
- 2 Flutes with 30° Helix angle
- 140° drill point angle

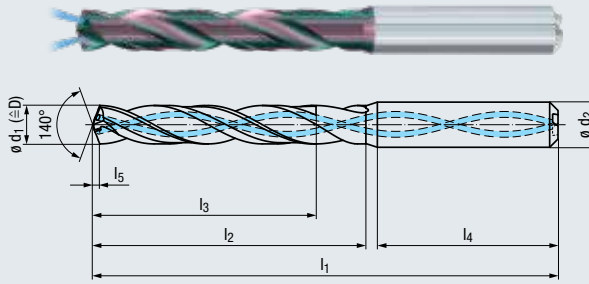

Applications - Materials

P	1.1-5.1
K	1.1-4.2
S	1.2-1.3, 2.2-2.3
H	1.1-1.3

Product Finder / Range of Applications and Material Descriptions (see pages 4-5)
Cutting Data (see pages 54-55)

Nominal Size				Taps	Roll Form Taps	mm					EDP No. HA SHANK	
ϕd_1 m7 Tolerance						l_1	l_2	l_3	l_4	l_5		ϕd_2 h6 Tol.
Inch	Fraction	Wire letter	mm									
0.2656	17/64"		6.746			91	53	43	36	1.3	8	TA211544.0675
0.2677			6.800	M8, G 1/16		91	53	43	36	1.3	8	TA211544.0680
0.2717			6.900	5/16-24 UNF		91	53	43	36	1.3	8	TA211544.0690
0.2756			7.000	5/16-24 UNJF		91	53	43	36	1.3	8	TA211544.0700
0.2795			7.100	MJ8x1		91	53	43	36	1.3	8	TA211544.0710
0.2813	9/32	K	7.145			91	53	43	36	1.3	8	TA211544.0715
0.2835			7.200	5/16-32 UNEF		91	53	43	36	1.4	8	TA211544.0720
0.2854			7.250		5/16-18 UNC	91	53	43	36	1.4	8	TA211544.0725
0.2874			7.300			91	53	43	36	1.4	8	TA211544.0730
0.2913			7.400			91	53	43	36	1.4	8	TA211544.0740
0.2933			7.450		5/16-24 UNF, M8	91	53	43	36	1.4	8	TA211544.0745
0.2953			7.500	M8x0.5		91	53	43	36	1.4	8	TA211544.0750
0.2969	19/64"		7.541			91	53	43	36	1.4	8	TA211544.0754
0.2992			7.600	Tr9x1.5	M8x1, STI-M8	91	53	43	36	1.4	8	TA211544.0760
0.3031			7.700		M8x0.75	91	53	43	36	1.5	8	TA211544.0770
0.3071			7.800	M9		91	53	43	36	1.5	8	TA211544.0780
0.3110			7.900	BSW 3/8-16		91	53	43	36	1.5	8	TA211544.0790
0.3125	5/16"		7.938			91	53	43	36	1.5	8	TA211544.0794
0.3150			8.000	3/8-16 UNC		91	53	43	36	1.5	8	TA211544.0800
0.3189			8.100	3/8-16 UNJC		103	61	49	40	1.5	10	TA211544.0810
0.3228			8.200	M9x0.75		103	61	49	40	1.5	10	TA211544.0820
0.3268			8.300	LK-UNC 3/8-16		103	61	49	40	1.6	10	TA211544.0830
0.3281	21/64"		8.334			103	61	49	40	1.6	10	TA211544.0833
0.3307			8.400	STI 5/16-18		103	61	49	40	1.6	10	TA211544.0840
0.3327			8.450			103	61	49	40	1.6	10	TA211544.0845
0.3346			8.500	3/8-24 UNF, M10		103	61	49	40	1.6	10	TA211544.0850
0.3386			8.600	3/8-24 UNJF	M9x1	103	61	49	40	1.6	10	TA211544.0860
0.3425			8.700	3/8-32 UNEF	M9x0.75	103	61	49	40	1.6	10	TA211544.0870
0.3438	11/32"		8.733	1/8-27 NPSC		103	61	49	40	1.6	10	TA211544.0873
0.3465			8.800	M10x1.25	3/8-16 UNC	103	61	49	40	1.7	10	TA211544.0880
0.3504			8.900	MJ10x1.25		103	61	49	40	1.7	10	TA211544.0890
0.3543			9.000	M10x1		103	61	49	40	1.7	10	TA211544.0900
0.3563			9.050		3/8-24 UNF	103	61	49	40	1.7	10	TA211544.0905
0.3583			9.100	1/8-27 NPSM		103	61	49	40	1.7	10	TA211544.0910
0.3594	23/64"		9.129			103	61	49	40	1.7	10	TA211544.0913
0.3622			9.200	M10x0.75		103	61	49	40	1.7	10	TA211544.0920
0.3661			9.300			103	61	49	40	1.7	10	TA211544.0930
0.3681			9.350		M10	103	61	49	40	1.8	10	TA211544.0935
0.3701			9.400	7/16-14 UNC		103	61	49	40	1.8	10	TA211544.0940
0.3720			9.450			103	61	49	40	1.8	10	TA211544.0945
0.3740			9.500	7/16-14 UNJC	STI-M10	103	61	49	40	1.8	10	TA211544.0950
0.3750	3/8"		9.525			103	61	49	40	1.8	10	TA211544.0953
0.3780			9.600		M10x1	103	61	49	40	1.8	10	TA211544.0960
0.3819			9.700	LK-UNC 7/16-14	M10x0.75	103	61	49	40	1.8	10	TA211544.0970
0.3858			9.800	STI 3/8-24		103	61	49	40	1.8	10	TA211544.0980
0.3898			9.900	7/16-20 UNF		103	61	49	40	1.9	10	TA211544.0990
0.3906	25/64"		9.921			103	61	49	40	1.9	10	TA211544.0992
0.3937			10.000	7/16-20 UNJF		103	61	49	40	1.9	10	TA211544.1000
0.3976			10.100			118	71	56	45	1.9	12	TA211544.1010
0.4016			10.200	7/16-28 UNEF		118	71	56	45	1.9	12	TA211544.1020
0.4035			10.250		7/16-14 UNC	118	71	56	45	1.9	12	TA211544.1025
0.4055			10.300			118	71	56	45	1.9	12	TA211544.1030
0.4063	13/32"		10.320			118	71	56	45	1.9	12	TA211544.1032
0.4075			10.350			118	71	56	45	1.9	12	TA211544.1035
0.4094			10.400			118	71	56	45	1.9	12	TA211544.1040
0.4134			10.500	M12x1.5		118	71	56	45	2.0	12	TA211544.1050
0.4154			10.550		7/16-20 UNF	118	71	56	45	2.0	12	TA211544.1055
0.4173			10.600			118	71	55	45	2.0	12	TA211544.1060
0.4213			10.700	LK-M12		118	71	56	45	2.0	12	TA211544.1070
0.4219	27/64"		10.716	1/2-13 UNC		118	71	56	45	2.0	12	TA211544.1072
0.4252			10.800	M12x1.25		118	71	56	45	2.0	12	TA211544.1080
0.4291			10.900	1/2-13 UNJC		118	71	56	45	2.0	12	TA211544.1090
0.4331			11.000	M12x1		118	71	56	45	2.1	12	TA211544.1100
0.4370			11.100	BSF 1/2-16		118	71	56	45	2.1	12	TA211544.1110



5 x D - Axial Coolant (continued)

- High performance carbide drill for reduced cycle times
- Sub-micro grain carbide
- ALTiN-112 Coating
- Double-margin flute design
- 2 Flutes with 30° Helix angle
- 140° drill point angle

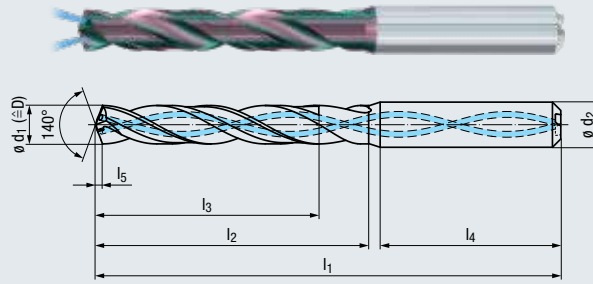

Applications - Materials

P	1.1-5.1
K	1.1-4.2
S	1.2-1.3, 2.2-2.3
H	1.1-1.3

Product Finder / Range of Applications and Material Descriptions (see pages 4-5)
Cutting Data (see pages 54-55)

Nominal Size ø d ₁ m7 Tolerance				Taps	Roll Form Taps	mm					EDP No. HA SHANK	
Inch	Fraction	Wire letter	mm			l ₁	l ₂	l ₃	l ₄	l ₅	ø d ₂ h6 Tol.	
0.4375	7/16"		11.113	LK-UNC 1/2-13		118	71	56	45	2.1	12	TA211544.1111
0.4409			11.200			118	71	56	45	2.1	12	TA211544.1120
0.4429			11.250	M12x0.75	M12	118	71	56	45	2.1	12	TA211544.1125
0.4449			11.300			118	71	56	45	2.1	12	TA211544.1130
0.4469			11.350		M12x1.5	118	71	56	45	2.1	12	TA211544.1135
0.4488			11.400	1/4-18 NPSC		118	71	56	45	2.1	12	TA211544.1140
0.4508			11.450		M12x1.25	118	71	56	45	2.1	12	TA211544.1145
0.4528			11.500	1/2-20 UNF		118	71	56	45	2.1	12	TA211544.1150
0.4531	29/64"		11.509			118	71	56	45	2.1	12	TA211544.1151
0.4567			11.600	1/2-20 UNJF	M12x1	118	71	56	45	2.2	12	TA211544.1160
0.4606			11.700			118	71	56	45	2.2	12	TA211544.1170
0.4646			11.800	1/2-28 UNEF	1/2-13 UNC	118	71	56	45	2.2	12	TA211544.1180
0.4685			11.900			118	71	56	45	2.2	12	TA211544.1190
0.4688	15/32"		11.908			118	71	56	45	2.2	12	TA211544.1191
0.4724			12.000	M14		118	71	56	45	2.2	12	TA211544.1200
0.4783			12.150		1/2-20 UNF	124	77	60	45	2.2	14	TA211544.1215
0.4803			12.200	Tr 14x2		124	77	60	45	2.3	14	TA211544.1220
0.4844	31/64"		12.304	9/16-12 UNC		124	77	60	45	2.3	14	TA211544.1230
0.4921			12.500	M14x1.5		124	77	60	45	2.3	14	TA211544.1250
0.4941			12.550		G 1/4-19	124	77	60	45	2.3	14	TA211544.1255
0.4961			12.600			124	77	60	45	2.3	14	TA211544.1260
0.5000	1/2"		12.700	LK-UNC 9/16-12		124	77	60	45	2.4	14	TA211544.1270
0.5039			12.800	M14x1.25		124	77	60	45	2.4	14	TA211544.1280
0.5118			13.000	9/16-18 UNJF		124	77	60	45	2.4	14	TA211544.1300
0.5157			13.100	STI-1/2-20	M14	124	77	60	45	2.4	14	TA211544.1310
0.5236			13.300	9/16-24 UNEF	9/16-12 UNC	124	77	60	45	2.5	14	TA211544.1330
0.5256			13.350		M14x1.5	124	77	60	45	2.5	14	TA211544.1335
0.5295			13.450		M14x1.25	124	77	60	45	2.5	14	TA211544.1345
0.5313	17/32"		13.495	5/8-11 UNC		124	77	60	45	2.5	14	TA211544.1349
0.5315			13.500			124	77	60	45	2.5	14	TA211544.1350
0.5354			13.600			124	77	60	45	2.5	14	TA211544.1360
0.5374			13.650	5/8-11 UNJC	9/16-18 UNF	124	77	60	45	2.5	14	TA211544.1365
0.5394			13.700			124	77	60	45	2.5	14	TA211544.1370
0.5433			13.800			124	77	60	45	2.6	14	TA211544.1380
0.5469	35/64"		13.891			124	77	60	45	2.6	14	TA211544.1389
0.5512			14.000	M16, M15x1		124	77	60	45	2.6	14	TA211544.1400
0.5551			14.100			133	83	63	48	2.6	16	TA211544.1410
0.5625	9/16"		14.290			133	83	63	48	2.6	16	TA211544.1429
0.5709			14.500	5/8-18 UNF		133	83	63	48	2.7	16	TA211544.1450
0.5748			14.600	5/8-18 UNJF	M15x1	133	83	63	48	2.7	16	TA211544.1460
0.5781	37/64"		14.684	9/8-18 NPSC		133	83	63	48	2.7	16	TA211544.1468
0.5827			14.800		5/8-11 UNC	133	83	63	48	2.7	16	TA211544.1480
0.5906			15.000	M16x1		133	83	63	48	2.8	16	TA211544.1500
0.5938	19/32"		15.083			133	83	63	48	2.8	16	TA211544.1508
0.5945			15.100		M16	133	83	63	48	2.8	16	TA211544.1510
0.6043			15.350			133	83	63	48	2.8	16	TA211544.1535
0.6102			15.500	M18		133	83	63	48	2.9	16	TA211544.1550
0.6142			15.600		M16x1	133	83	63	48	2.9	16	TA211544.1560
0.6250	5/8"		15.875			133	83	63	48	2.9	16	TA211544.1588
0.6299			16.000	M18x2		133	83	63	48	3.0	16	TA211544.1600
0.6406	41/64"		16.272			143	93	71	48	3.0	18	TA211544.1627
0.6496			16.500	STI-5/8-11		143	93	71	48	3.1	18	TA211544.1650
0.6563	21/32"		16.669	3/4-10 UNC		143	93	71	48	3.1	18	TA211544.1667
0.6693			17.000	M18x1		143	93	71	48	3.1	18	TA211544.1700
0.6875	11/16"		17.463			143	93	71	48	3.1	18	TA211544.1746
0.6890			17.500	3/4-16 UNF, M20		143	93	71	48	3.2	18	TA211544.1750
0.7087			18.000	M20x2, LK-M16		143	93	71	48	3.3	18	TA211544.1800
0.7500	3/4"		19.050			153	101	77	50	3.3	20	TA211544.1905



8 x D - Coolant Fed

- Advanced sub-micro grain carbide substrate
- ALTiN-112 flute coating up to 3 x D for better chip formation and cutting edge protection
- Concave cutting edge
- Slightly adapted drill point but still with 135° drill point angle
- Four-margin design up to 4 x D for superb accuracy
- Beyond 4 x D bright polished flutes with clearance relief to maximize chip evacuation and reduce contact with the workpiece

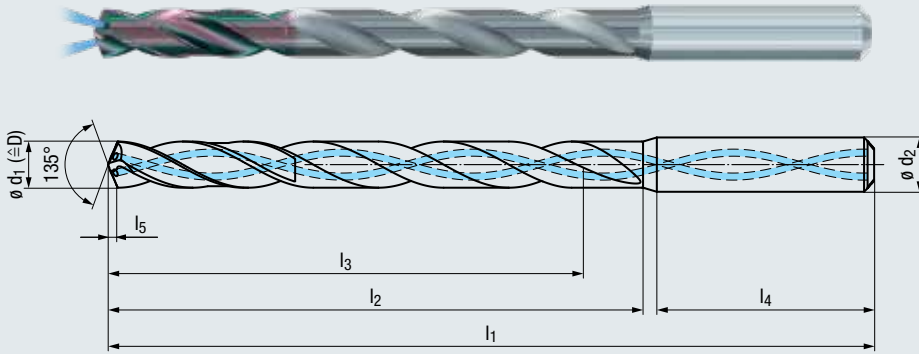

Applications - Materials

P	1.1-5.1
K	1.1-4.2
N	1.1-1.6, 2.1-2.8
S	1.2-1.3, 2.2-2.3
H	1.1-1.3

Product Finder / Range of Applications and Material Descriptions (see pages 4-5)
Cutting Data (see pages 54-55)

Nominal Size ø d ₁ m7 Tolerance				Taps	Roll Form Taps	mm					EDP No. HA SHANK	
Inch	Fraction	Wire letter	mm			l ₁	l ₂	l ₃	l ₄	l ₅	ø d ₂ h6 Tol.	
0.1102			2.800	#6-32UNC	M3	70	30	24	36	0.6	6	TA223344.0280
0.1142			2.900	#6-32UNJC	#5-40UNC	70	30	24	36	0.6	6	TA223344.0290
0.1150			2.920		#5-44UNF	70	30	24	36	0.6	6	TA223344.0292
0.1181			3.000	#6-40UNF		78	38	30	36	0.6	6	TA223344.0300
0.1220			3.100	STI-#4-40		78	38	30	36	0.6	6	TA223344.0310
0.1240			3.150	M3.5x0.35	#6-32UNC	78	38	30	36	0.7	6	TA223344.0315
0.1250	1/8"		3.175			78	38	30	36	0.7	6	TA223344.0318
0.1260			3.200	BSW ⁵ /32-32	#6-40UNF	78	38	30	36	0.7	6	TA223344.0320
0.1280			3.250		M3.5	78	38	30	36	0.7	6	TA223344.0325
0.1299			3.300		M4	78	38	30	36	0.7	6	TA223344.0330
0.1331			3.380		M3.5x0.35	78	38	30	36	0.7	6	TA223344.0338
0.1339			3.400	MJ4x0.7		78	38	30	36	0.7	6	TA223344.0340
0.1378			3.500	#8-32UNC		78	38	30	36	0.7	6	TA223344.0350
0.1406	9/64"	#28	3.571			78	38	30	36	0.7	6	TA223344.0357
0.1417			3.600	#8-36UNJF		78	38	30	36	0.7	6	TA223344.0360
0.1457			3.700	M4.5	M4	78	38	30	36	0.8	6	TA223344.0370
0.1496		#25	3.800	STI-#6-32	#8-32UNC	88	48	38	36	0.8	6	TA223344.0380
0.1516			3.850		#8-36UNF	88	48	38	36	0.8	6	TA223344.0385
0.1535			3.900	#10-24UNC		88	48	38	36	0.8	6	TA223344.0390
0.1563	5/32"		3.970			88	48	38	36	0.8	6	TA223344.0397
0.1575			4.000	M4.5x0.5		88	48	38	36	0.8	6	TA223344.0400
0.1590		#21	4.038			88	48	38	36	0.8	6	TA223344.0404
0.1614			4.100	#10-32UNF		88	48	38	36	0.8	6	TA223344.0410
0.1654			4.200	M5, STI-M4	M4.5	88	48	38	36	0.9	6	TA223344.0420
0.1693		#18	4.300	MJ5x0.8		88	48	38	36	0.9	6	TA223344.0430
0.1713			4.350		#10-24UNC	88	48	38	36	0.9	6	TA223344.0435
0.1719	11/64"		4.366			88	48	38	36	0.9	6	TA223344.0437
0.1732			4.400	M5x0.75		88	48	38	36	0.9	6	TA223344.0440
0.1752			4.450		#10-32UNF	88	48	38	36	0.9	6	TA223344.0445
0.1772			4.500	#12-24UNC		88	48	38	36	0.9	6	TA223344.0450
0.1811			4.600	#12-28UNF		88	48	38	36	1.0	6	TA223344.0460
0.1831			4.650	#12-24UNJC	M5	88	48	38	36	1.0	6	TA223344.0465
0.1850		#13	4.700	LK-UNC#12-24		88	48	38	36	1.0	6	TA223344.0470
0.1875	3/16"		4.763	#12-28UNJF		97	60	48	36	1.0	6	TA223344.0476
0.1890		#12	4.800	#12-32UNEF	M5x0.5, STI-M5	97	60	48	36	1.0	6	TA223344.0480
0.1929			4.900			97	60	48	36	1.0	6	TA223344.0490
0.1969			5.000	M6	#12-24UNC	97	60	48	36	1.0	6	TA223344.0500
0.2008			5.100	MJ6x1	#12-28UNF	97	60	48	36	1.1	6	TA223344.0510
0.2010		#7	5.106			97	60	48	36	1.1	6	TA223344.0511
0.2031	13/64"		5.159			97	60	48	36	1.1	6	TA223344.0516
0.2047			5.200	1/4-20UNC		97	60	48	36	1.1	6	TA223344.0520
0.2087			5.300	1/4-20UNJC		97	60	48	36	1.1	6	TA223344.0530
0.2126			5.400			97	60	48	36	1.1	6	TA223344.0540
0.2130		#3	5.410			97	60	48	36	1.1	6	TA223344.0541



8 x D - Coolant Fed (continued)

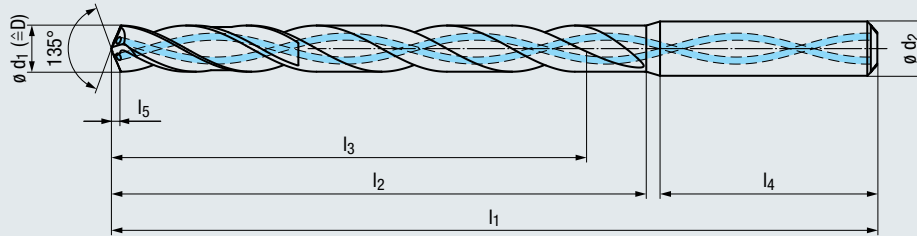

- Advanced sub-micro grain carbide substrate
- ALTiN-112 flute coating up to 3 x D for better chip formation and cutting edge protection
- Concave cutting edge
- Slightly adapted drill point but still with 135° drill point angle
- Four-margin design up to 4 x D for superb accuracy
- Beyond 4 x D bright polished flutes with clearance relief to maximize chip evacuation and reduce contact with the workpiece



Applications - Materials

P	1.1-5.1
K	1.1-4.2
N	1.1-1.6, 2.1-2.8
S	1.2-1.3, 2.2-2.3
H	1.1-1.3

Product Finder / Range of Applications and Material Descriptions (see pages 4-5)
Cutting Data (see pages 54-55)

Nominal Size ϕd_1 m7 Tolerance				Taps	Roll Form Taps	mm					EDP No. HA SHANK	
Inch	Fraction	Wire letter	mm			l_1	l_2	l_3	l_4	l_5		ϕd_2 h6 Tol.
0.2165			5.500	1/4-28 UNF		97	60	48	36	1.1	6	TA223344.0550
0.2187	7/32"		5.556	1/4-28 UNJF		97	60	48	36	1.1	6	TA223344.0556
0.2205			5.600	1/4-32 UNEF	M6	97	60	48	36	1.2	6	TA223344.0560
0.2264			5.750		1/4-20 UNC	97	60	48	36	1.2	6	TA223344.0575
0.2283			5.800		M6x0.5	97	60	48	36	1.2	6	TA223344.0580
0.2323			5.900			97	60	48	36	1.2	6	TA223344.0590
0.2344	15/64"		5.954		1/4-28 UNF	97	60	48	36	1.2	6	TA223344.0595
0.2362			6.000	M7, Rd 8x1/10		97	60	48	36	1.2	6	TA223344.0600
0.2402			6.100	MJ7x1		107	70	56	36	1.3	8	TA223344.0610
0.2441			6.200	M7x0.75		107	70	56	36	1.3	8	TA223344.0620
0.2480			6.300	M7x0.5, STI-M6		107	70	56	36	1.3	8	TA223344.0630
0.2500	1/4"	E	6.350	1/16-27 NPSF		107	70	56	36	1.3	8	TA223344.0635
0.2520			6.400			107	70	56	36	1.3	8	TA223344.0640
0.2559			6.500	BSW 5/16-18		107	70	56	36	1.3	8	TA223344.0650
0.2570		F	6.528			107	70	56	36	1.3	8	TA223344.0653
0.2598			6.600	5/16-18 UNC	M7	107	70	56	36	1.4	8	TA223344.0660
0.2638			6.700	5/16-18 UNJC	M7x0.75	107	70	56	36	1.4	8	TA223344.0670
0.2656	17/64"		6.746			107	70	56	36	1.4	8	TA223344.0675
0.2677			6.800	M8, G 1/16		107	70	56	36	1.4	8	TA223344.0680
0.2717			6.900	5/16-24 UNF		107	70	56	36	1.4	8	TA223344.0690
0.2756			7.000	5/16-24 UNJF		107	70	56	36	1.4	8	TA223344.0700
0.2795			7.100	MJ8x1		117	80	64	36	1.5	8	TA223344.0710
0.2813	9/32"	K	7.145			117	80	64	36	1.5	8	TA223344.0715
0.2835			7.200	5/16-32 UNEF		117	80	64	36	1.5	8	TA223344.0720
0.2854			7.250		5/16-18 UNC	117	80	64	36	1.5	8	TA223344.0725
0.2874			7.300			117	80	64	36	1.5	8	TA223344.0730
0.2913			7.400			117	80	64	36	1.5	8	TA223344.0740
0.2933			7.450		5/16-24 UNF, M8	117	80	64	36	1.5	8	TA223344.0745
0.2953			7.500	M8x0.5		117	80	64	36	1.6	8	TA223344.0750
0.2969	19/64"		7.541			117	80	64	36	1.6	8	TA223344.0754
0.2992			7.600	Tr9x1.5	M8x1, STI-M8	117	80	64	36	1.6	8	TA223344.0760
0.3031			7.700		M8x0.75	117	80	64	36	1.6	8	TA223344.0770
0.3071			7.800	M9		117	80	64	36	1.6	8	TA223344.0780
0.3110			7.900	BSW 3/8-16		117	80	64	36	1.6	8	TA223344.0790
0.3125	5/16"		7.938			117	80	64	36	1.6	8	TA223344.0794
0.3150			8.000	3/8-16 UNC		117	80	64	36	1.7	8	TA223344.0800
0.3189			8.100	3/8-16 UNJC		141	100	80	40	1.7	10	TA223344.0810
0.3228			8.200		M9x0.75	141	100	80	40	1.7	10	TA223344.0820
0.3268			8.300	LK-UNC 3/8-16		141	100	80	40	1.7	10	TA223344.0830
0.3281	21/64"		8.334			141	100	80	40	1.7	10	TA223344.0833
0.3307			8.400	STI-5/16-18		141	100	80	40	1.7	10	TA223344.0840
0.3346			8.500	3/8-24 UNF, M10		141	100	80	40	1.8	10	TA223344.0850
0.3386			8.600	3/8-24 UNJF	M9x1	141	100	80	40	1.8	10	TA223344.0860
0.3425			8.700	3/8-32 UNEF	M9x0.75	141	100	80	40	1.8	10	TA223344.0870

8 x D - Coolant Fed (continued)

- Advanced sub-micro grain carbide substrate
- ALTiN-112 flute coating up to 3 x D for better chip formation and cutting edge protection
- Concave cutting edge
- Slightly adapted drill point but still with 135° drill point angle
- Four-margin design up to 4 x D for superb accuracy
- Beyond 4 x D bright polished flutes with clearance relief to maximize chip evacuation and reduce contact with the workpiece

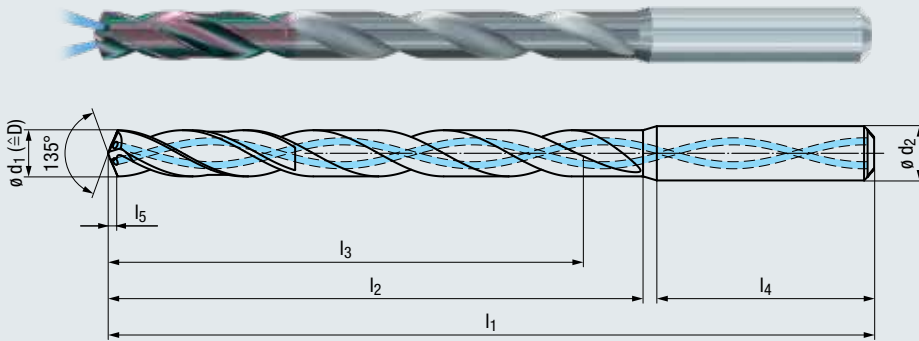

Applications - Materials

P	1.1-5.1
K	1.1-4.2
N	1.1-1.6, 2.1-2.8
S	1.2-1.3, 2.2-2.3
H	1.1-1.3

Product Finder / Range of Applications and Material Descriptions (see pages 4-5)
Cutting Data (see pages 54-55)

Nominal Size ϕd_1 m7 Tolerance				Taps	Roll Form Taps	mm					EDP No. HA SHANK	
Inch	Fraction	Wire letter	mm			l_1	l_2	l_3	l_4	l_5	ϕd_2 h6 Tol.	
0.3438	11/32"		8.733	1/8-27 NPSC		141	100	80	40	1.8	10	TA223344.0873
0.3465			8.800	M10x1.25	3/8-16 UNC	141	100	80	40	1.8	10	TA223344.0880
0.3504			8.900	MJ10x1.25		141	100	80	40	1.8	10	TA223344.0890
0.3543			9.000	M10x1		141	100	80	40	1.9	10	TA223344.0900
0.3563			9.050		3/8-24 UNF	141	100	80	40	1.9	10	TA223344.0905
0.3583			9.100	1/8-27 NPSM		141	100	80	40	1.9	10	TA223344.0910
0.3594	23/64"		9.129			141	100	80	40	1.9	10	TA223344.0913
0.3622			9.200	M10x0.75		141	100	80	40	1.9	10	TA223344.0920
0.3642			9.250			141	100	80	40	1.9	10	TA223344.0925
0.3661			9.300			141	100	80	40	1.9	10	TA223344.0930
0.3681			9.350		M10	141	100	80	40	1.9	10	TA223344.0935
0.3701			9.400	7/16-14 UNC		141	100	80	40	1.9	10	TA223344.0940
0.3740			9.500	7/16-14 UNJC	STI-M10	141	100	80	40	2.0	10	TA223344.0950
0.3750	3/8"		9.525			141	100	80	40	2.0	10	TA223344.0953
0.3780			9.600		M10x1	141	100	80	40	2.0	10	TA223344.0960
0.3819			9.700	LK-UNC7/16-14	M10x0.75	141	100	80	40	2.0	10	TA223344.0970
0.3858			9.800	STI-3/8-24		141	100	80	40	2.0	10	TA223344.0980
0.3898			9.900	7/16-20 UNF		141	100	80	40	2.1	10	TA223344.0990
0.3906	25/64"		9.921			141	100	80	40	2.1	10	TA223344.0992
0.3937			10.000	7/16-20 UNJF		141	100	80	40	2.1	10	TA223344.1000
0.3976			10.100			166	120	96	45	2.1	12	TA223344.1010
0.4016			10.200	7/16-28 UNEF		166	120	96	45	2.1	12	TA223344.1020
0.4035			10.250		7/16-14 UNC	166	120	96	45	2.1	12	TA223344.1025
0.4055			10.300			166	120	96	45	2.1	12	TA223344.1030
0.4063	13/32"		10.320			166	120	96	45	2.1	12	TA223344.1032
0.4134			10.500	M12x1.5		166	120	96	45	2.2	12	TA223344.1050
0.4154			10.550		7/16-20 UNF	166	120	96	45	2.2	12	TA223344.1055
0.4213			10.700	LK-M12		166	120	96	45	2.2	12	TA223344.1070
0.4219	27/64"		10.716	1/2-13 UNC		166	120	96	45	2.2	12	TA223344.1072
0.4252			10.800	M12x1.25		166	120	96	45	2.2	12	TA223344.1080
0.4291			10.900	1/2-13 UNJC		166	120	96	45	2.3	12	TA223344.1090
0.4331			11.000	M12x1		166	120	96	45	2.3	12	TA223344.1100
0.4370			11.100	BSF 1/2-16		166	120	96	45	2.3	12	TA223344.1110
0.4375	7/16"		11.113	LK-UNC 1/2-13		166	120	96	45	2.3	12	TA223344.1111
0.4409			11.200			166	120	96	45	2.3	12	TA223344.1120
0.4429			11.250	M12x0.75	M12	166	120	96	45	2.3	12	TA223344.1125
0.4469			11.350		M12x1.5	166	120	96	45	2.4	12	TA223344.1135
0.4488			11.400	1/4-18 NPSC		166	120	96	45	2.4	12	TA223344.1140
0.4508			11.450		M12x1.25	166	120	96	45	2.4	12	TA223344.1145
0.4528			11.500	1/2-20 UNF		166	120	96	45	2.4	12	TA223344.1150
0.4531	29/64"		11.509			166	120	96	45	2.4	12	TA223344.1151
0.4567			11.600	1/2-20 UNJF	M12x1	166	120	96	45	2.4	12	TA223344.1160
0.4606			11.700			166	120	96	45	2.4	12	TA223344.1170
0.4646			11.800	1/2-28 UNEF	1/2-13 UNC	166	120	96	45	2.4	12	TA223344.1180



8 x D - Coolant Fed (continued)

- Advanced sub-micro grain carbide substrate
- ALTiN-112 flute coating up to 3 x D for better chip formation and cutting edge protection
- Concave cutting edge
- Slightly adapted drill point but still with 135° drill point angle
- Four-margin design up to 4 x D for superb accuracy
- Beyond 4 x D bright polished flutes with clearance relief to maximize chip evacuation and reduce contact with the workpiece

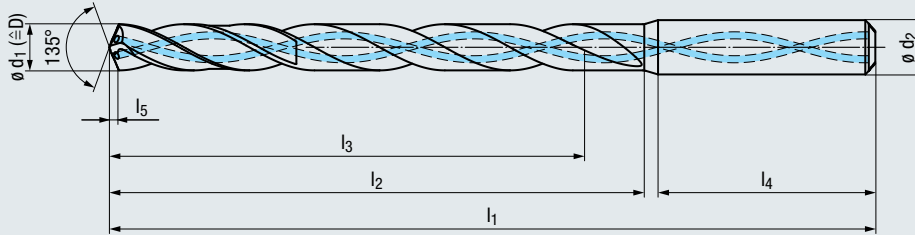

Applications - Materials

P	1.1-5.1
K	1.1-4.2
N	1.1-1.6, 2.1-2.8
S	1.2-1.3, 2.2-2.3
H	1.1-1.3

Product Finder / Range of Applications and Material Descriptions (see pages 4-5)
Cutting Data (see pages 54-55)

Nominal Size ø d ₁ m7 Tolerance				Taps	Roll Form Taps	mm					EDP No. HA SHANK	
Inch	Fraction	Wire letter	mm			l ₁	l ₂	l ₃	l ₄	l ₅		ø d ₂ h6 Tol.
0.4685			11.900			166	120	96	45	2.5	12	TA223344.1190
0.4688	15/32"		11.908			166	120	96	45	2.5	12	TA223344.1191
0.4724			12.000	M14		166	120	96	45	2.5	12	TA223344.1200
0.4783			12.150		1/2-20 UNF	186	140	112	45	2.5	14	TA223344.1215
0.4803			12.200	Tr 14x2		186	140	112	45	2.5	14	TA223344.1220
0.4844	31/64"		12.304	9/16-12 UNC		186	140	112	45	2.5	14	TA223344.1230
0.4921			12.500	M14x1.5		186	140	112	45	2.6	14	TA223344.1250
0.4941			12.550		G 1/4-19	186	140	112	45	2.6	14	TA223344.1255
0.5000	1/2"		12.700	LK-UNC 9/16-12		186	140	112	45	2.6	14	TA223344.1270
0.5039			12.800	M14x1.25		186	140	112	45	2.7	14	TA223344.1280
0.5118			13.000	9/16-18 UNJF		186	140	112	45	2.7	14	TA223344.1300
0.5157			13.100	STI-1/2-20	M14	186	140	112	45	2.7	14	TA223344.1310
0.5236			13.300	9/16-24 UNEF	9/16-12 UNC	186	140	112	45	2.8	14	TA223344.1330
0.5256			13.350		M14x1.5	186	140	112	45	2.8	14	TA223344.1335
0.5295			13.450		M14x1.25	186	140	112	45	2.8	14	TA223344.1345
0.5313	17/32"		13.495	5/8-11 UNC		186	140	112	45	2.8	14	TA223344.1349
0.5315			13.500			186	140	112	45	2.8	14	TA223344.1350
0.5374			13.650	5/8-11 UNJC	9/16-18 UNF	186	140	112	45	2.8	14	TA223344.1365
0.5394			13.700			186	140	112	45	2.8	14	TA223344.1370
0.5469	35/64"		13.891			186	140	112	45	2.8	14	TA223344.1389
0.5512			14.000	M16, M15x1		186	140	112	45	2.9	14	TA223344.1400
0.5551			14.100			209	160	128	45	2.9	16	TA223344.1410
0.5625	9/16"		14.288			209	160	128	45	2.9	16	TA223344.1429
0.5709			14.500	5/8-18 UNF		209	160	128	48	3.0	16	TA223344.1450
0.5748			14.600	5/8-18 UNJF	M15x1	209	160	128	48	3.0	16	TA223344.1460
0.5781	37/64"		14.684	3/8-18 NPSC		209	160	128	48	3.0	16	TA223344.1468
0.5827			14.800		5/8-11 UNC	209	160	128	48	3.0	16	TA223344.1480
0.5906			15.000	M16x1		209	160	128	48	3.1	16	TA223344.1500
0.5938	19/32"		15.083			209	160	128	48	3.1	16	TA223344.1508
0.5945			15.100		M16	209	160	128	48	3.1	16	TA223344.1510
0.6102			15.500	M18		209	160	128	48	3.2	16	TA223344.1550
0.6142			15.600		M16x1	209	160	128	48	3.2	16	TA223344.1560
0.6250	5/8"		15.875			209	160	128	48	3.2	16	TA223344.1588
0.6299			16.000	M18x2		209	160	128	48	3.3	16	TA223344.1600
0.6406	41/64"		16.272			229	180	144	48	3.4	18	TA223344.1627
0.6496			16.500	STI-5/8-11		229	180	144	48	3.4	18	TA223344.1650
0.6563	21/32"		16.669	3/4-10 UNC		229	180	144	48	3.5	18	TA223344.1667
0.6693			17.000	M18x1		229	180	144	48	3.5	18	TA223344.1700
0.6875	11/16"		17.463			229	180	144	48	3.6	18	TA223344.1746
0.6890			17.500	3/4-16 UNF, M20		229	180	144	48	3.6	18	TA223344.1750
0.7087			18.000	M20x2, LK-M16		229	180	144	48	3.7	18	TA223344.1800
0.7480			19.000	M20x1		251	200	160	50	3.9	20	TA223344.1900
0.7500	3/4"		19.050			251	200	160	50	3.9	20	TA223344.1905
0.7874			20.000	M22x2	G 1/2-14	251	200	160	50	4.0	20	TA223344.2000

EF-Drills



High-Performance EF-Drills

Unlike EMUGE MultiDRILLS which are general purpose drills that perform well across a wide range of materials and applications, EF-Drills are designed specifically for premium performance in demanding applications and materials.

EMUGE EF style drills are primarily designed for steel, alloyed steel, martensitic stainless steel and nickel alloys common in aerospace. Although these drills can be used in other materials, they are best suited for ferrous and aerospace materials.

EMUGE EF-Drills are offered in a 12 x D length drilling depth, provide optimized chip evacuation, and are ideal for deep hole applications requiring straightness and surface quality beyond a standard high speed steel drill.

EMUGE EF-Drills feature a double-margin design, reverse web taper and coolant hole channels that prevent chip packing and premature tool failure. Drills are designed to operate without peck cycles to reduce cycle times. EF-Drills feature TiAlN based multi-layer coatings, are post-polished and specifically formulated for deep hole drilling.

12 x D - Coolant Fed

- Double-margins for better guidance and hole quality
- Internal cooling channels for high process reliability
- Special TiAlN coating for excellent wear resistance and drilling performance
- Specialized web construction allows optimized chip evacuation
- 135° drill point angle
- Preparatory spot drill may be required using a 142° degree point angle.

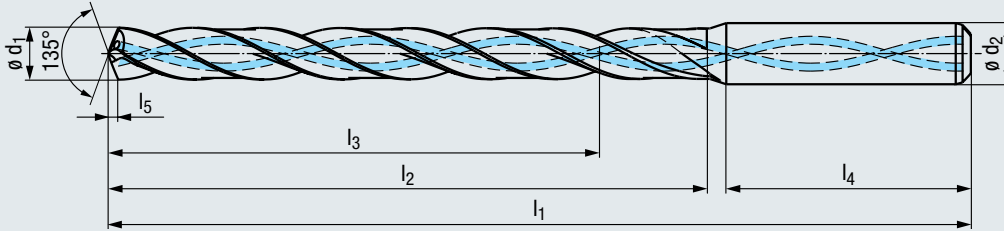

Applications - Materials

P	1.1-5.1
M	1.1
K	1.1-3.2
H	1.1

Product Finder / Range of Applications and Material Descriptions (see pages 4-5)
Cutting Data (see page 56)

Nominal Size θd_1 m7 Tolerance				Taps	Roll Form Taps	mm					EDP No. HA SHANK	
Inch	Fraction	Wire letter	mm			l_1	l_2	l_3	l_4	l_5	θd_2 h6 Tol.	
0.1181			3.000	UNJF 6-40, MJ3.5x0.6		92	54	48	36	0.6	6	TA233344.0300
0.1220			3.100			92	54	48	36	0.6	6	TA233344.0310
0.1248	1/8"		3.175			92	54	48	36	0.6	6	TA233344.0318
0.1260			3.200			92	54	48	36	0.6	6	TA233344.0320
0.1299			3.300	M4	M3.5x0.5	92	54	48	36	0.6	6	TA233344.0330
0.1339			3.400	MJ4x0.7		92	54	48	36	0.6	6	TA233344.0340
0.1378			3.500	UNC 8-32, UNF 8-36, UNJC 8-32, M4x0.5		92	54	48	36	0.6	6	TA233344.0350
0.1406	9/64"	#28	3.571			92	54	48	36	0.6	6	TA233344.0357
0.1417			3.600			92	54	48	36	0.7	6	TA233344.0360
0.1457			3.700	M4.5	M4, MJ4x0.7	92	54	48	36	0.7	6	TA233344.0370
0.1496		#25	3.800		UNC 8-32, M4x0.5	102	64	58	36	0.7	6	TA233344.0380
0.1535			3.900	UNJC 10-24, UNC 10-24,		102	64	58	36	0.7	6	TA233344.0390
0.1563	5/32"		3.970			102	64	58	36	0.7	6	TA233344.0397
0.1575			4.000	M4,5x0,5		102	64	58	36	0.7	6	TA233344.0400
0.1590		#21	4.038			102	64	58	36	0.7	6	TA233344.0404
0.1614			4.100	UNF 10-32,		102	64	58	36	0.8	6	TA233344.0410
0.1654			4.200	M5	M4,5	102	64	58	36	0.8	6	TA233344.0420
0.1693		#18	4.300	MJ5x0.8	M4.5x0.5	102	64	58	36	0.8	6	TA233344.0430
0.1719	11/64"		4.366			102	64	58	36	0.8	6	TA233344.0437
0.1732			4.400	M5x0.75		102	64	58	36	0.8	6	TA233344.0440
0.1772			4.500	UNC 12-24, M5x0.5	UNF 10-32	102	64	58	36	0.8	6	TA233344.0450
0.1811			4.600	UNF 12-28,		102	64	58	36	0.8	6	TA233344.0460
0.1850		#13	4.700		M5x0.75	102	64	58	36	0.9	6	TA233344.0470
0.1875	3/16"		4.763	12-28 UNJF		116	78	70	36	0.9	6	TA233344.0476
0.1890		#12	4.800		M5x0,5	116	78	70	36	0.9	6	TA233344.0480
0.1969			5.000	M6		116	78	70	36	0.9	6	TA233344.0500
0.2008			5.100	MJ6x1	UNF 12-28	116	78	70	36	0.9	6	TA233344.0510
0.2010		#7	5.106	1/4 -28 UNJF		116	78	70	36	0.9	6	TA233344.0511
0.2031	13/64"		5.159			116	78	70	36	0.9	6	TA233344.0516
0.2047			5.200	M6x0.75		116	78	70	36	1.0	6	TA233344.0520
0.2126			5.400			116	78	70	36	1.0	6	TA233344.0540
0.2130		#3	5.410			116	78	70	36	1.0	6	TA233344.0541
0.2165			5.500	UNF 1/4-28, M6x0.5		116	78	70	36	1.0	6	TA233344.0550
0.2187	7/32"		5.556			116	78	70	36	1.0	6	TA233344.0556
0.2205			5.600		M6	116	78	70	36	1.0	6	TA233344.0560
0.2283			5.800		M6x0.5	116	78	70	36	1.1	6	TA233344.0580
0.2323			5.900			116	78	70	36	1.1	6	TA233344.0590
0.2344	15/64"		5.954			116	78	70	36	1.1	6	TA233344.0595
0.2362			6.000	M7		116	78	70	36	1.1	6	TA233344.0600
0.2402			6.100	MJ7x1		146	108	94	36	1.1	8	TA233344.0610
0.2441			6.200	M7x0.75		146	108	94	36	1.1	8	TA233344.0620
0.2480			6.300			146	108	94	36	1.2	8	TA233344.0630
0.2500	1/4"	E	6.350	1/16 -27 NPSF		146	108	94	36	1.2	8	TA233344.0635
0.2559			6.500	M7x0.5		146	108	94	36	1.2	8	TA233344.0650
0.2570		F	6.528			146	108	94	36	1.2	8	TA233344.0653
0.2656	17/64"		6.746			146	108	94	36	1.2	8	TA233344.0675
0.2677			6.800	G1/16, M8	M7x0.5	146	108	94	36	1.2	8	TA233344.0680
0.2756			7.000	UNJF 5/16-24, M8x1		146	108	94	36	1.3	8	TA233344.0700
0.2813	9/32"	K	7.145			146	108	94	36	1.3	8	TA233344.0715



12 x D - Coolant Fed (continued)

- Double-margins for better guidance and hole quality
- Internal cooling channels for high process reliability
- Special TiAlN coating for excellent wear resistance and drilling performance
- Specialized web construction allows optimized chip evacuation
- 135° drill point angle
- Preparatory spot drill may be required using a 142° degree point angle.

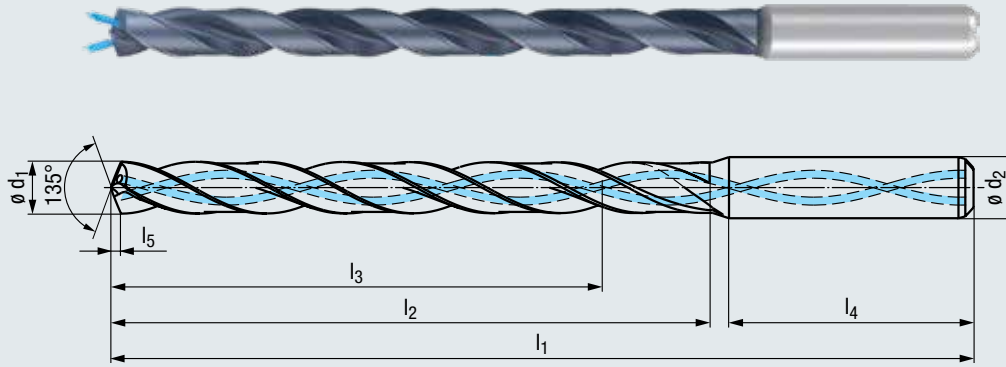

Applications - Materials

P	1.1-5.1
M	1.1
K	1.1-3.2
H	1.1

Product Finder / Range of Applications and Material Descriptions (see pages 4-5)

Cutting Data (see page 56)

Nominal Size ϕd_1 , m7 Tolerance				Taps	Roll Form Taps	mm					EDP No. HA SHANK	
Inch	Fraction	Wire letter	mm			l_1	l_2	l_3	l_4	l_5	ϕd_2 h6 Tol.	
0.2835			7.200	M8x0.75		146	108	94	36	1.3	8	TA233344.0720
0.2874			7.300		UNC 5/16-18	146	108	94	36	1.3	8	TA233344.0730
0.2953			7.500	M8x0.5		146	108	94	36	1.4	8	TA233344.0750
0.2969	19/64"		7.541			146	108	94	36	1.4	8	TA233344.0754
0.3071			7.800	M9	M8x0.5	146	108	94	36	1.4	8	TA233344.0780
0.3110			7.900			146	108	94	36	1.4	8	TA233344.0790
0.3125	5/16"		7.938			146	108	94	36	1.4	8	TA233344.0794
0.3150			8.000	UNC 3/8-16, M9x1		146	108	94	36	1.5	8	TA233344.0800
0.3189			8.100	UNJC 3/8-16		162	120	110	40	1.5	10	TA233344.0810
0.3268			8.300			162	120	110	40	1.5	10	TA233344.0830
0.3281	21/64"		8.334			162	120	110	40	1.5	10	TA233344.0833
0.3346			8.500	UNF 3/8-24, M10		162	120	110	40	1.5	10	TA233344.0850
0.3386			8.600	UNJF 3/8-24, MJ10x1.5	M9x1	162	120	110	40	1.5	10	TA233344.0860
0.3425			8.700	UNEF 3/8-32	M9x0.75	162	120	110	40	1.5	10	TA233344.0870
0.3438	11/32"		8.733	1/8-27 NPSC		162	120	110	40	1.5	10	TA233344.0873
0.3465			8.800	G1/8, M10x1.25	UNC 3/8-16, M9x0.5	162	120	110	40	1.5	10	TA233344.0880
0.3543			9.000	M10x1		162	120	110	40	1.6	10	TA233344.0900
0.3583			9.100			162	120	110	40	1.7	10	TA233344.0910
0.3594	23/64"		9.129			162	120	110	40	1.7	10	TA233344.0913
0.3701			9.400	UNC 7/16-14, M10x0.5, M11		162	120	110	40	1.7	10	TA233344.0940
0.3740			9.500			162	120	110	40	1.7	10	TA233344.0950
0.3750	3/8"		9.525			162	120	110	40	1.7	10	TA233344.0953
0.3780			9.600		M10x1	162	120	110	40	1.7	10	TA233344.0960
0.3819			9.700		M10x0.75	162	120	110	40	1.8	10	TA233344.0970
0.3858			9.800		M10x0.5	162	120	110	40	1.8	10	TA233344.0980
0.3898			9.900	UNF 7/16-20		162	120	110	40	1.8	10	TA233344.0990
0.3906	25/64"		9.921			162	120	110	40	1.8	10	TA233344.0992
0.3937			10.000	M11x1		162	120	110	40	1.8	10	TA233344.1000
0.3976			10.100			204	156	142	45	1.8	12	TA233344.1010
0.4016			10.200	UNEF 7/16-28, M11x0.75, M12		204	156	142	45	1.9	12	TA233344.1020
0.4063	13/32"		10.320			204	156	142	45	1.9	12	TA233344.1032
0.4134			10.500	M12x1.5		204	156	142	45	1.9	12	TA233344.1050
0.4219	27/64"		10.716	1/2 -13 UNC		204	156	142	45	1.9	12	TA233344.1072
0.4331			11.000	M12x1		204	156	142	45	1.9	12	TA233344.1100
0.4375	7/16"		11.113			204	156	142	45	1.9	12	TA233344.1111
0.4528			11.500	UNF 1/2-20		204	156	142	45	1.9	12	TA233344.1150
0.4531	29/64"		11.509			204	156	142	45	1.9	12	TA233344.1151
0.4688	15/32"		11.908			204	156	142	45	1.9	12	TA233344.1191
0.4724			12.000	M13x1, M14		204	156	142	45	1.9	12	TA233344.1200
0.4844	31/64"		12.304	9/16 -12 UNC		230	182	166	45	2.3	14	TA233344.1230
0.4921			12.500	M14x1.5		230	182	166	45	2.3	14	TA233344.1250
0.5000	1/2"		12.700	LK-UNC 9/16 -12		230	182	166	45	2.3	14	TA233344.1270
0.5118			13.000	M14x1		230	182	166	45	2.3	14	TA233344.1300
0.5313	17/32"		13.495	5/8 -11 UNC		230	182	166	45	2.3	14	TA233344.1349
0.5315			13.500	UNC 5/8-11		230	182	166	45	2.3	14	TA233344.1350
0.5469	35/64"		13.891			230	182	166	45	2.3	14	TA233344.1389
0.5512			14.000	M15x1, M16		230	182	166	45	2.3	14	TA233344.1400



InoxDrill

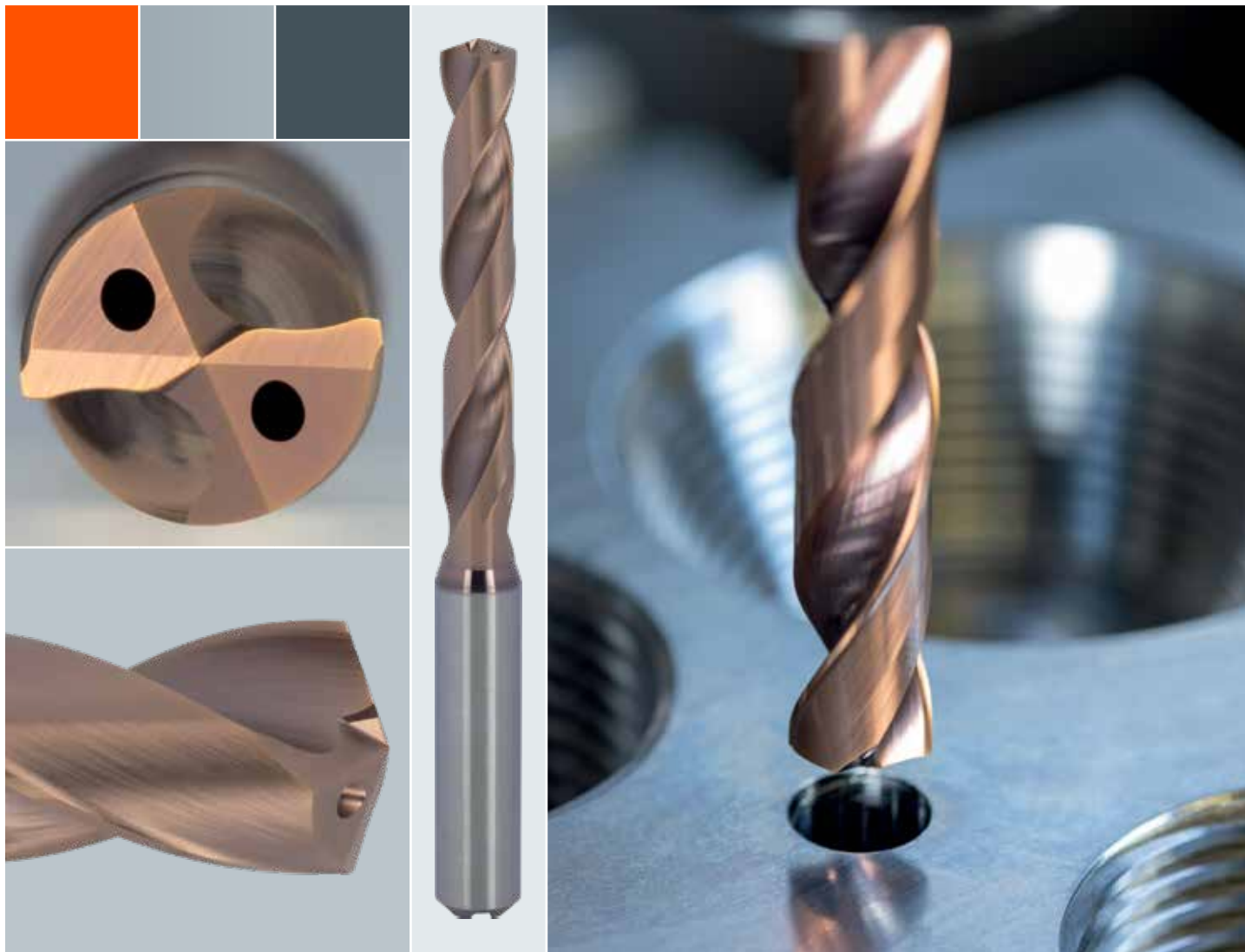

High-Performance InoxDrill

The InoxDrill line is ideal for machining stainless steel and materials that are prone to adhere to cutting tools and are available in diameters from .1181 to .7500 (3.00 to 19.05 mm).

InoxDrills also achieve good results in non-ferrous materials. Drills are available in 3 x D and 5 x D sizes.

- Single-margin design for reduced material adhesion and excellent hole guidance
- Internal cooling design
- High-performance coating and polishing for high process reliability

Cutting Edge Shape and Preparation

Concave primary cutting edge combined with an optimized edge preparation enables excellent results in stainless steel and other demanding materials at very high feed rates.

Custom EMUGE Coating and Polishing Process

enables superb, high speed cutting and exceptionally long tool life.

Open, Smooth Flute Design

for easy, trouble-free chip evacuation.

Single-Margin Design

reduces material adhesion while providing excellent guidance in the hole. Ideal for materials that can jam a drill.

Point Geometry

Optimized point design allows maximum space for chip forming and coolant distribution.

Coolant-fed Shank

designed for both coolant and minimum quantity lubrication (MQL) applications.



3 x D - Axial Coolant

- Special EMUGE coating and polishing process for high speed / long tool life
- Sub-micro grain carbide
- ALCR-89 Coating
- 2 Flutes with 30° Helix angle
- 140° drill point angle

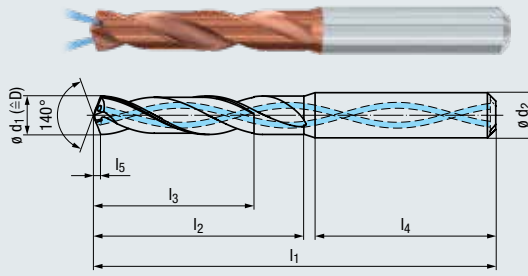

Applications - Materials

M	1.1-4.1
N	1.1-2.3
S	1.2-1.3, 2.2-2.3

Product Finder / Range of Applications and Material Descriptions (see pages 4-5)
Cutting Data (see pages 58-59)

Nominal Size Ø d ₁ m7 Tolerance				Taps	Roll Form Taps	mm					EDP No. HA SHANK	
Inch	Fraction	Wire letter	mm			l ₁	l ₂	l ₃	l ₄	l ₅	Ø d ₂ h6 Tol.	
0.1181			3.000	#6-40 UNF		62	20	14	36	0.6	6	TA201724.0300
0.1220			3.100	STI-#4-40		62	20	14	36	0.6	6	TA201724.0310
0.1240			3.150	M3.5x0.35	#6-32 UNC	62	20	14	36	0.6	6	TA201724.0315
0.1250	1/8"		3.175			62	20	14	36	0.6	6	TA201724.0318
0.1260			3.200	BSW ⁵ /32-32	#6-40 UNF	62	20	14	36	0.6	6	TA201724.0320
0.1268			3.220			62	20	14	36	0.6	6	TA201724.0322
0.1280			3.250		M3.5	62	20	14	36	0.6	6	TA201724.0325
0.1299			3.300	M4		62	20	14	36	0.7	6	TA201724.0330
0.1319			3.350			62	20	14	36	0.7	6	TA201724.0335
0.1331			3.380		M3.5x0.35	62	20	14	36	0.7	6	TA201724.0338
0.1339			3.400	MJ4x0.7		62	20	14	36	0.7	6	TA201724.0340
0.1378			3.500	#8-32 UNC		62	20	14	36	0.7	6	TA201724.0350
0.1406	9/64	#28	3.571			62	20	14	36	0.7	6	TA201724.0357
0.1417			3.600	#8-36 UNJF		62	20	14	36	0.7	6	TA201724.0360
0.1437			3.650			62	20	14	36	0.7	6	TA201724.0365
0.1457			3.700	M4.5	M4	62	20	14	36	0.7	6	TA201724.0370
0.1496		#25	3.800	STI-#6-32	#8-32 UNC	66	24	17	36	0.7	6	TA201724.0380
0.1516			3.850		#8-36 UNF	66	24	17	36	0.8	6	TA201724.0385
0.1528			3.880			66	24	17	36	0.8	6	TA201724.0388
0.1535			3.900	#10-24 UNC		66	24	17	36	0.8	6	TA201724.0390
0.1563	5/32"		3.970			66	24	17	36	0.8	6	TA201724.0397
0.1575			4.000	M4.5x0.5		66	24	17	36	0.8	6	TA201724.0400
0.1590		#21	4.038			66	24	17	36	0.8	6	TA201724.0404
0.1614			4.100	#10-32 UNF		66	24	17	36	0.8	6	TA201724.0410
0.1634			4.150			66	24	17	36	0.8	6	TA201724.0415
0.1654			4.200	M5, STI-M4	M4.5	66	24	17	36	0.8	6	TA201724.0420
0.1693		#18	4.300	MJ5x0.8		66	24	17	36	0.8	6	TA201724.0430
0.1713			4.350		#10-24 UNC	66	24	17	36	0.8	6	TA201724.0435
0.1719	11/64"		4.366			66	24	17	36	0.8	6	TA201724.0437
0.1732			4.400	M5x0.75		66	24	17	36	0.9	6	TA201724.0440
0.1752			4.450		#10-32 UNF	66	24	17	36	0.9	6	TA201724.0445
0.1772			4.500	#12-24 UNC		66	24	17	36	0.9	6	TA201724.0450
0.1811			4.600	#12-28 UNF		66	24	17	36	0.9	6	TA201724.0460
0.1831			4.650	#12-24 UNJC	M5	66	24	17	36	0.9	6	TA201724.0465
0.1850		#13	4.700	LK-UNC #12-24		66	24	17	36	0.9	6	TA201724.0470
0.1875	3/16"		4.763	#12-28 UNJF		66	28	17	36	0.9	6	TA201724.0476
0.1890		#12	4.800	#12-32 UNEF	M5x0.5, STI-M5	66	28	20	36	0.9	6	TA201724.0480
0.1929			4.900			66	28	20	36	0.9	6	TA201724.0490
0.1969			5.000	M6	#12-24 UNC	66	28	20	36	1.0	6	TA201724.0500
0.2008			5.100	MJ6x1	#12-28 UNF	66	28	20	36	1.0	6	TA201724.0510
0.2010		#7	5.106			66	28	20	36	1.0	6	TA201724.0511
0.2031	13/64"		5.159			66	28	20	36	1.0	6	TA201724.0516
0.2047			5.200	1/4-20 UNC		66	28	20	36	1.0	6	TA201724.0520
0.2087			5.300	1/4-20 UNJC		66	28	20	36	1.0	6	TA201724.0530
0.2126			5.400			66	28	20	36	1.0	6	TA201724.0540
0.2130		#3	5.410			66	28	20	36	1.0	6	TA201724.0541
0.2165			5.500	1/4-28 UNF		66	28	20	36	1.1	6	TA201724.0550
0.2187	7/32"		5.556	1/4-28 UNJF		66	28	20	36	1.1	6	TA201724.0556
0.2205			5.600	1/4-32 UNEF	M6	66	28	20	36	1.1	6	TA201724.0560
0.2244			5.700			66	28	20	36	1.1	6	TA201724.0570
0.2264			5.750		1/4-20 UNC	66	28	20	36	1.1	6	TA201724.0575
0.2283			5.800		M6x0.5	66	28	20	36	1.1	6	TA201724.0580
0.2323			5.900			66	28	20	36	1.1	6	TA201724.0590
0.2344	15/64"		5.954		1/4-28 UNF	66	28	20	36	1.1	6	TA201724.0595
0.2362			6.000	M7, Rd 8x1/10		66	28	20	36	1.1	6	TA201724.0600
0.2402			6.100	MJ7x1		79	34	24	36	1.2	8	TA201724.0610
0.2441			6.200	M7x0.75		79	34	24	36	1.2	8	TA201724.0620
0.2480			6.300	M7x0.5, STI-M6		79	34	24	36	1.2	8	TA201724.0630
0.2500	1/4	E	6.350	1/16-27 NPSF		79	34	24	36	1.2	8	TA201724.0635
0.2520			6.400			79	34	24	36	1.2	8	TA201724.0640
0.2559			6.500	BSW ⁵ /16-18		79	34	24	36	1.2	8	TA201724.0650
0.2570		F	6.528			79	34	24	36	1.3	8	TA201724.0653
0.2598			6.600	5/16-18 UNC	M7	79	34	24	36	1.3	8	TA201724.0660
0.2638			6.700	5/16-18 UNJC	M7x0.75	79	34	24	36	1.3	8	TA201724.0670

3 x D - Axial Coolant (continued)

- Special EMUGE coating and polishing process for high speed / long tool life
- Sub-micro grain carbide
- ALCR-89 Coating
- 2 Flutes with 30° Helix angle
- 140° drill point angle

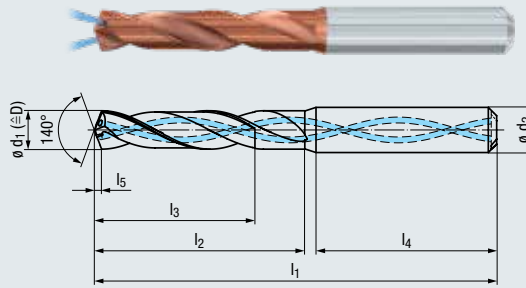

Applications - Materials

M	1.1-4.1
N	1.1-2.3
S	1.2-1.3, 2.2-2.3

Product Finder / Range of Applications and Material Descriptions (see pages 4-5)
Cutting Data (see pages 58-59)

Nominal Size ø d ₁ m7 Tolerance				Taps	Roll Form Taps	mm					EDP No. HA SHANK	
Inch	Fraction	Wire letter	mm			l ₁	l ₂	l ₃	l ₄	l ₅		ø d ₂ h6 Tol.
0.2656	17/64"		6.746			79	34	24	36	1.3	8	TA201724.0675
0.2677			6.800	M8, G 1/16		79	34	24	36	1.3	8	TA201724.0680
0.2717			6.900	5/16-24 UNF		79	34	24	36	1.3	8	TA201724.0690
0.2756			7.000	5/16-24 UNJF		79	34	24	36	1.3	8	TA201724.0700
0.2795			7.100	MJ8x1		79	41	29	36	1.3	8	TA201724.0710
0.2813	9/32"	K	7.145			79	41	29	36	1.4	8	TA201724.0715
0.2835			7.200	5/16-32 UNEF		79	41	29	36	1.4	8	TA201724.0720
0.2854			7.250		5/16-18 UNC	79	41	29	36	1.4	8	TA201724.0725
0.2874			7.300			79	41	29	36	1.4	8	TA201724.0730
0.2913			7.400			79	41	29	36	1.4	8	TA201724.0740
0.2933			7.450		5/16-24 UNF, M8	79	41	29	36	1.4	8	TA201724.0745
0.2953			7.500	M8x0.5		79	41	29	36	1.4	8	TA201724.0750
0.2969	19/64"		7.541			79	41	29	36	1.4	8	TA201724.0754
0.2992			7.600	Tr9x1.5	M8x1, STI-M8	79	41	29	36	1.4	8	TA201724.0760
0.3031			7.700		M8x0.75	79	41	29	36	1.5	8	TA201724.0770
0.3071			7.800	M9		79	41	29	36	1.5	8	TA201724.0780
0.3110			7.900	BSW 3/8-16		79	41	29	36	1.5	8	TA201724.0790
0.3125	5/16"		7.938			79	41	29	36	1.5	8	TA201724.0794
0.3150			8.000	3/8-16 UNC		79	41	29	36	1.5	8	TA201724.0800
0.3189			8.100	3/8-16 UNJC		89	47	35	40	1.5	10	TA201724.0810
0.3228			8.200	M9x0.75		89	47	35	40	1.5	10	TA201724.0820
0.3268			8.300	LK-UNC 3/8-16		89	47	35	40	1.6	10	TA201724.0830
0.3281	21/64"		8.334			89	47	35	40	1.6	10	TA201724.0833
0.3307			8.400	STI-5/16-18		89	47	35	40	1.6	10	TA201724.0840
0.3327			8.450			89	47	35	40	1.6	10	TA201724.0845
0.3346			8.500	3/8-24 UNF, M10		89	47	35	40	1.6	10	TA201724.0850
0.3386			8.600	3/8-24 UNJF	M9x1	89	47	35	40	1.6	10	TA201724.0860
0.3425			8.700	3/8-32 UNEF	M9x0.75	89	47	35	40	1.6	10	TA201724.0870
0.3438	11/32"		8.733	1/8-27 NPSC		89	47	35	40	1.7	10	TA201724.0873
0.3465			8.800	M10x1.25	3/8-16 UNC	89	47	35	40	1.7	10	TA201724.0880
0.3504			8.900	MJ10x1.25		89	47	35	40	1.7	10	TA201724.0890
0.3543			9.000	M10x1		89	47	35	40	1.7	10	TA201724.0900
0.3563			9.050		3/8-24 UNF	89	47	35	40	1.7	10	TA201724.0905
0.3583			9.100	1/8-27 NPSM		89	47	35	40	1.7	10	TA201724.0910
0.3594	23/64"		9.129			89	47	35	40	1.7	10	TA201724.0913
0.3622			9.200	M10x0.75		89	47	35	40	1.7	10	TA201724.0920
0.3661			9.300			89	47	35	40	1.7	10	TA201724.0930
0.3681			9.350		M10	89	47	35	40	1.8	10	TA201724.0935
0.3701			9.400	7/16-14 UNC		89	47	35	40	1.8	10	TA201724.0940
0.3720			9.450			89	47	35	40	1.8	10	TA201724.0945
0.3740			9.500	7/16-14 UNJC	STI-M10	89	47	35	40	1.8	10	TA201724.0950
0.3750	3/8"		9.525			89	47	35	40	1.8	10	TA201724.0953
0.3780			9.600		M10x1	89	47	35	40	1.8	10	TA201724.0960
0.3819			9.700	LK-UNC 7/16-14	M10x0.75	89	47	35	40	1.8	10	TA201724.0970
0.3858			9.800	STI-3/8-24		89	47	35	40	1.8	10	TA201724.0980
0.3898			9.900	7/16-20 UNF		89	47	35	40	1.9	10	TA201724.0990
0.3906	25/64"		9.921			89	47	35	40	1.9	10	TA201724.0992
0.3937			10.000	7/16-20 UNJF		89	47	35	40	1.9	10	TA201724.1000
0.3976			10.100			102	55	40	45	1.9	12	TA201724.1010
0.4016			10.200	7/16-28 UNEF		102	55	40	45	1.9	12	TA201724.1020
0.4035			10.250		7/16-14 UNC	102	55	40	45	1.9	12	TA201724.1025
0.4055			10.300			102	55	40	45	1.9	12	TA201724.1030
0.4063	13/32"		10.320			102	55	40	45	1.9	12	TA201724.1032
0.4075			10.350			102	55	40	45	1.9	12	TA201724.1035
0.4094			10.400			102	55	40	45	1.9	12	TA201724.1040
0.4134			10.500	M12x1.5		102	55	40	45	2.0	12	TA201724.1050
0.4154			10.550		7/16-20 UNF	102	55	40	45	2.0	12	TA201724.1055
0.4173			10.600			102	55	40	45	2.0	12	TA201724.1060
0.4213			10.700	LK-M12		102	55	40	45	2.0	12	TA201724.1070
0.4219	27/64"		10.716	1/2-13 UNC		102	55	40	45	2.0	12	TA201724.1072
0.4252			10.800	M12x1.25		102	55	40	45	2.0	12	TA201724.1080
0.4291			10.900	1/2-13 UNJC		102	55	40	45	2.0	12	TA201724.1090
0.4331			11.000	M12x1		102	55	40	45	2.1	12	TA201724.1100
0.4370			11.100	BSF 1/2-16		102	55	40	45	2.1	12	TA201724.1110



3 x D - Axial Coolant (continued)

- Special EMUGE coating and polishing process for high speed / long tool life
- Sub-micro grain carbide
- ALCR-89 Coating
- 2 Flutes with 30° Helix angle
- 140° drill point angle

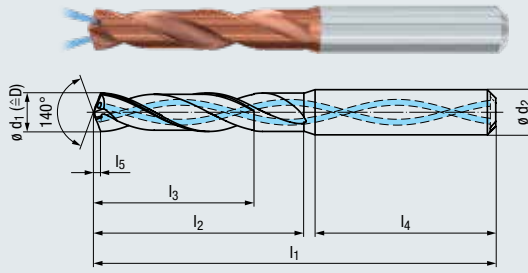

Applications - Materials

M	1.1-4.1
N	1.1-2.3
S	1.2-1.3, 2.2-2.3

Product Finder / Range of Applications and Material Descriptions (see pages 4-5)
Cutting Data (see pages 58-59)

Nominal Size ϕd_1 m7 Tolerance				Taps	Roll Form Taps	mm					EDP No. HA SHANK	
Inch	Fraction	Wire letter	mm			l_1	l_2	l_3	l_4	l_5	ϕd_2 h6 Tol.	
0.4375			11.113	LK-UNC 1/2-13		102	55	40	45	2.1	12	TA201724.1111
0.4409			11.200			102	55	40	45	2.1	12	TA201724.1120
0.4429			11.250	M12x0.75	M12	102	55	40	45	2.1	12	TA201724.1125
0.4449			11.300			102	55	40	45	2.1	12	TA201724.1130
0.4469			11.350		M12x1.5	102	55	40	45	2.1	12	TA201724.1135
0.4488			11.400	1/4-18 NPSC		102	55	40	45	2.1	12	TA201724.1140
0.4508			11.450		M12x1.25	102	55	40	45	2.1	12	TA201724.1145
0.4528			11.500	1/2-20 UNF		102	55	40	45	2.1	12	TA201724.1150
0.4531	29/64"		11.509			102	55	40	45	2.1	12	TA201724.1151
0.4567			11.600	1/2-20 UNJF	M12x1	102	55	40	45	2.2	12	TA201724.1160
0.4606			11.700			102	55	40	45	2.2	12	TA201724.1170
0.4646			11.800	1/2-28 UNEF	1/2-13 UNC	102	55	40	45	2.2	12	TA201724.1180
0.4685			11.900			102	55	40	45	2.2	12	TA201724.1190
0.4688	15/32"		11.908			102	55	40	45	2.2	12	TA201724.1191
0.4724			12.000	M14		102	55	40	45	2.2	12	TA201724.1200
0.4783			12.150		1/2-20 UNF	107	60	43	45	2.2	14	TA201724.1215
0.4803			12.200	Tr 14x2		107	60	43	45	2.3	14	TA201724.1220
0.4844	31/64"		12.304	9/16-12 UNC		107	60	43	45	2.3	14	TA201724.1230
0.4921			12.500	M14x1.5		107	60	43	45	2.3	14	TA201724.1250
0.4941			12.550		G 1/4-19	107	60	43	45	2.3	14	TA201724.1255
0.4961			12.600			107	60	43	45	2.3	14	TA201724.1260
0.5000	1/2"		12.700	LK-UNC 9/16-12		107	60	43	45	2.4	14	TA201724.1270
0.5039			12.800	M14x1.25		107	60	43	45	2.4	14	TA201724.1280
0.5118			13.000	9/16-18 UNJF		107	60	43	45	2.4	14	TA201724.1300
0.5157			13.100	STI-1/2-20	M14	107	60	43	45	2.4	14	TA201724.1310
0.5236			13.300	9/16-24 UNEF	9/16-12 UNC	107	60	43	45	2.5	14	TA201724.1330
0.5256			13.350		M14x1.5	107	60	43	45	2.5	14	TA201724.1335
0.5295			13.450		M14x1.25	107	60	43	45	2.5	14	TA201724.1345
0.5313	17/32"		13.495	5/8-11 UNC		107	60	43	45	2.5	14	TA201724.1349
0.5315			13.500			107	60	43	45	2.5	14	TA201724.1350
0.5354			13.600			107	60	43	45	2.5	14	TA201724.1360
0.5374			13.650	5/8-11 UNJC	9/16-18 UNF	107	60	43	45	2.5	14	TA201724.1365
0.5394			13.700			107	60	43	45	2.5	14	TA201724.1370
0.5433			13.800			107	60	43	45	2.6	14	TA201724.1380
0.5469	35/64"		13.891			107	60	43	45	2.6	14	TA201724.1389
0.5512			14.000	M16, M15x1		107	60	43	45	2.6	14	TA201724.1400
0.5551			14.100			115	65	45	48	2.6	16	TA201724.1410
0.5625	9/16"		14.290			115	65	45	48	2.6	16	TA201724.1429
0.5709			14.500	5/8-18 UNF		115	65	45	48	2.7	16	TA201724.1450
0.5748			14.600	5/8-18 UNJF	M15x1	115	65	45	48	2.7	16	TA201724.1460
0.5781	37/64"		14.684	3/8-18 NPSC		115	65	45	48	2.7	16	TA201724.1468
0.5827			14.800		5/8-11 UNC	115	65	45	48	2.7	16	TA201724.1480
0.5906			15.000	M16x1		115	65	45	48	2.8	16	TA201724.1500
0.5938	19/32"		15.083			115	65	45	48	2.8	16	TA201724.1508
0.5945			15.100			115	65	45	48	2.8	16	TA201724.1510
0.6043			15.350			115	65	45	48	2.8	16	TA201724.1535
0.6102			15.500	M18		115	65	45	48	2.9	16	TA201724.1550
0.6142			15.600		M16x1	115	65	45	48	2.9	16	TA201724.1560
0.6250	5/8"		15.875			115	65	45	48	2.9	16	TA201724.1588
0.6299			16.000	M18x2		115	65	45	48	3.0	16	TA201724.1600
0.6406	41/64"		16.272			123	73	51	48	3.0	18	TA201724.1627
0.6496			16.500	STI-5/8-11		123	73	51	48	3.1	18	TA201724.1650
0.6563	21/32"		16.669	3/4-10 UNC		123	73	51	48	3.1	18	TA201724.1667
0.6693			17.000	M18x1		123	73	51	48	3.1	18	TA201724.1700
0.6875	11/16"		17.463			123	73	51	48	3.1	18	TA201724.1746
0.6890			17.500	3/4-16 UNF, M20		123	73	51	48	3.2	18	TA201724.1750
0.7087			18.000	M20x2, LK-M16		123	73	51	48	3.3	18	TA201724.1800
0.7500	3/4"		19.050			131	79	55	50	3.6	20	TA201724.1905

5 x D - Axial Coolant

- Special EMUGE coating and polishing process for high speed / long tool life
- Sub-micro grain carbide
- ALCR-89 Coating
- 2 Flutes with 30° Helix angle
- 140° drill point angle

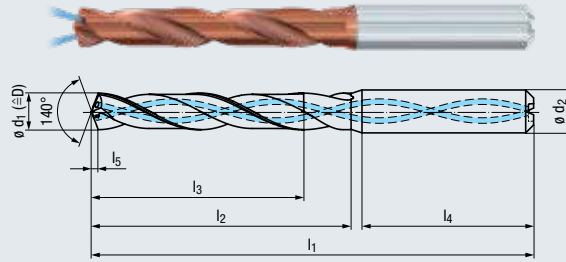

Applications - Materials

M	1.1-4.1
N	1.1-2.3
S	1.2-1.3, 2.2-2.3

Product Finder / Range of Applications and Material Descriptions (see pages 4-5)
Cutting Data (see pages 58-59)

Nominal Size Ø d ₁ m7 Tolerance				Taps	Roll Form Taps	mm					EDP No. HA SHANK	
Inch	Fraction	Wire letter	mm			l ₁	l ₂	l ₃	l ₄	l ₅	Ø d ₂ h6 Tol.	
0.1181			3.000	#6-40 UNF		66	28	23	36	0,6	6	TA211724.0300
0.1220			3.100	STI-#4-40		66	28	23	36	0,6	6	TA211724.0310
0.1240			3.150	M3.5x0.35	#6-32UNC	66	28	23	36	0,6	6	TA211724.0315
0.1250	1/8"		3.175			66	28	23	36	0,6	6	TA211724.0318
0.1260			3.200	BSW ⁵ /32-32	#6-40 UNF	66	28	23	36	0,6	6	TA211724.0320
0.1268			3.220			66	28	23	36	0,6	6	TA211724.0322
0.1280			3.250		M3.5	66	28	23	36	0,6	6	TA211724.0325
0.1299			3.300	M4		66	28	23	36	0,7	6	TA211724.0330
0.1319			3.350			66	28	23	36	0,7	6	TA211724.0335
0.1331			3.380		M3.5x0.35	66	28	23	36	0,7	6	TA211724.0338
0.1339			3.400	MJ4x0.7		66	28	23	36	0,7	6	TA211724.0340
0.1378			3.500	#8-32 UNC		66	28	23	36	0,7	6	TA211724.0350
0.1406	9/64	#28	3.571			66	28	23	36	0,7	6	TA211724.0357
0.1417			3.600	#8-36 UNJF		66	28	23	36	0,7	6	TA211724.0360
0.1437			3.650			66	28	23	36	0,7	6	TA211724.0365
0.1457			3.700	M4.5	M4	66	28	23	36	0,7	6	TA211724.0370
0.1496		#25	3.800	STI-#6-32	#8-32UNC	74	36	29	36	0,7	6	TA211724.0380
0.1516			3.850		#8-36 UNF	74	36	29	36	0,8	6	TA211724.0385
0.1528			3.880			74	36	29	36	0,8	6	TA211724.0388
0.1535			3.900	#10-24 UNC		74	36	29	36	0,8	6	TA211724.0390
0.1563	5/32"		3.970			74	36	29	36	0,8	6	TA211724.0397
0.1575			4.000	M4.5x0.5		74	36	29	36	0,8	6	TA211724.0400
0.1590		#21	4.038			74	36	29	36	0,8	6	TA211724.0404
0.1614			4.100	#10-32 UNF		74	36	29	36	0,8	6	TA211724.0410
0.1634			4.150			74	36	29	36	0,8	6	TA211724.0415
0.1654			4.200	M5, STI-M4	M4.5	74	36	29	36	0,8	6	TA211724.0420
0.1693		#18	4.300	MJ5x0.8		74	36	29	36	0,8	6	TA211724.0430
0.1713			4.350		#10-24 UNC	74	36	29	36	0,8	6	TA211724.0435
0.1719	11/64"		4.366			74	36	29	36	0,9	6	TA211724.0437
0.1732			4.400	M5x0.75		74	36	29	36	0,9	6	TA211724.0440
0.1752			4.450		#10-32 UNF	74	36	29	36	0,9	6	TA211724.0445
0.1772			4.500	#12-24 UNC		74	36	29	36	0,9	6	TA211724.0450
0.1811			4.600	#12-28 UNF		74	36	29	36	0,9	6	TA211724.0460
0.1831			4.650	#12-24 UNJC	M5	74	36	29	36	0,9	6	TA211724.0465
0.1850		#13	4.700	LK-UNC#12-24		74	36	29	36	0,9	6	TA211724.0470
0.1875	3/16"		4.763	#12-28 UNJF		82	44	35	36	0,9	6	TA211724.0476
0.1890		#12	4.800	#12-32 UNEF	M5x0.5, STI-M5	82	44	35	36	0,9	6	TA211724.0480
0.1929			4.900			82	44	35	36	0,9	6	TA211724.0490
0.1969			5.000	M6	#12-24 UNC	82	44	35	36	1,0	6	TA211724.0500
0.2008			5.100	MJ6x1	#12-28 UNF	82	44	35	36	1,0	6	TA211724.0510
0.2010		#7	5.106			82	44	35	36	1,0	6	TA211724.0511
0.2031	13/64"		5.159			82	44	35	36	1,0	6	TA211724.0516
0.2047			5.200	1/4-20 UNC		82	44	35	36	1,0	6	TA211724.0520
0.2087			5.300	1/4-20 UNJC		82	44	35	36	1,0	6	TA211724.0530
0.2126			5.400			82	44	35	36	1,0	6	TA211724.0540
0.2130		#3	5.410			82	44	35	36	1,0	6	TA211724.0541
0.2165			5.500	1/4-28 UNF		82	44	35	36	1,1	6	TA211724.0550
0.2187	7/32"		5.556	1/4-28 UNJF		82	44	35	36	1,1	6	TA211724.0556
0.2205			5.600	1/4-32 UNEF	M6	82	44	35	36	1,1	6	TA211724.0560
0.2244			5.700			82	44	35	36	1,1	6	TA211724.0570
0.2264			5.750		1/4-20 UNC	82	44	35	36	1,1	6	TA211724.0575
0.2283			5.800		M6x0.5	82	44	35	36	1,1	6	TA211724.0580
0.2323			5.900			82	44	35	36	1,1	6	TA211724.0590
0.2344	15/64"		5.954		1/4-28 UNF	82	44	35	36	1,1	6	TA211724.0595
0.2362			6.000	M7, Rd 8x1/10		82	44	35	36	1,1	6	TA211724.0600
0.2402			6.100	MJ7x1		91	53	43	36	1,2	8	TA211724.0610
0.2441			6.200	M7x0.75		91	53	43	36	1,2	8	TA211724.0620
0.2480			6.300	M7x0.5, STI-M6		91	53	43	36	1,2	8	TA211724.0630
0.2500	1/4	E	6.350	1/16-27 NPSF		91	53	43	36	1,2	8	TA211724.0635
0.2520			6.400			91	53	43	36	1,2	8	TA211724.0640
0.2559			6.500	BSW ⁵ /16-18		91	53	43	36	1,2	8	TA211724.0650
0.2570		F	6.528			91	53	43	36	1,2	8	TA211724.0653
0.2598			6.600	5/16-18 UNC	M7	91	53	43	36	1,3	8	TA211724.0660
0.2638			6.700	5/16-18 UNJC	M7x0.75	91	53	43	36	1,3	8	TA211724.0670



5 x D - Axial Coolant (continued)

- Special EMUGE coating and polishing process for high speed / long tool life
- Sub-micro grain carbide
- ALCR-89 Coating
- 2 Flutes with 30° Helix angle
- 140° drill point angle

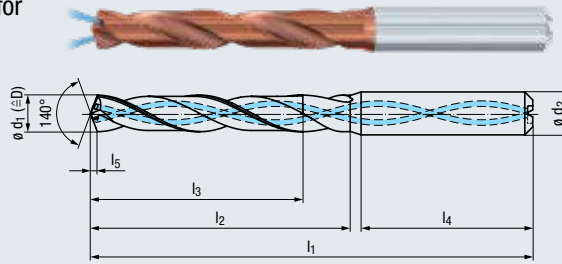

Applications - Materials

M	1.1-4.1
N	1.1-2.3
S	1.2-1.3, 2.2-2.3

Product Finder / Range of Applications and Material Descriptions (see pages 4-5)
Cutting Data (see pages 58-59)

Nominal Size ϕd_1 m7 Tolerance				Taps	Roll Form Taps	mm					EDP No. HA SHANK	
Inch	Fraction	Wire letter	mm			l_1	l_2	l_3	l_4	l_5	ϕd_2 h6 Tol.	
0.2656	17/64"		6.746			91	53	43	36	1.3	8	TA211724.0675
0.2677			6.800	M8, G 1/16		91	53	43	36	1.3	8	TA211724.0680
0.2717			6.900	5/16-24 UNF		91	53	43	36	1.3	8	TA211724.0690
0.2756			7.000	5/16-24 UNJF		91	53	43	36	1.3	8	TA211724.0700
0.2795			7.100	MJ8x1		91	53	43	36	1.3	8	TA211724.0710
0.2813	9/32	K	7.145			91	53	43	36	1.4	8	TA211724.0715
0.2835			7.200	5/16-32 UNEF		91	53	43	36	1.4	8	TA211724.0720
0.2854			7.250		5/16-18 UNC	91	53	43	36	1.4	8	TA211724.0725
0.2874			7.300			91	53	43	36	1.4	8	TA211724.0730
0.2913			7.400			91	53	43	36	1.4	8	TA211724.0740
0.2933			7.450		5/16-24 UNF, M8	91	53	43	36	1.4	8	TA211724.0745
0.2953			7.500	M8x0.5		91	53	43	36	1.4	8	TA211724.0750
0.2969	19/64"		7.541			91	53	43	36	1.4	8	TA211724.0754
0.2992			7.600	Tr9x1.5	M8x1, STI-M8	91	53	43	36	1.4	8	TA211724.0760
0.3031			7.700		M8x0.75	91	53	43	36	1.5	8	TA211724.0770
0.3071			7.800	M9		91	53	43	36	1.5	8	TA211724.0780
0.3110			7.900	BSW 3/8-16		91	53	43	36	1.5	8	TA211724.0790
0.3125	5/16"		7.938			91	53	43	36	1.5	8	TA211724.0794
0.3150			8.000	3/8-16 UNC		91	53	43	36	1.5	8	TA211724.0800
0.3189			8.100	3/8-16 UNJC		103	61	49	40	1.5	10	TA211724.0810
0.3228			8.200	M9x0.75		103	61	49	40	1.5	10	TA211724.0820
0.3268			8.300	LK-UNC 3/8-16		103	61	49	40	1.6	10	TA211724.0830
0.3281	21/64"		8.334			103	61	49	40	1.6	10	TA211724.0833
0.3307			8.400	STI 5/16-18		103	61	49	40	1.6	10	TA211724.0840
0.3327			8.450			103	61	49	40	1.6	10	TA211724.0845
0.3346			8.500	3/8-24 UNF, M10		103	61	49	40	1.6	10	TA211724.0850
0.3386			8.600	3/8-24 UNJF	M9x1	103	61	49	40	1.6	10	TA211724.0860
0.3425			8.700	3/8-32 UNEF	M9x0.75	103	61	49	40	1.6	10	TA211724.0870
0.3438	11/32"		8.733	1/8-27 NPSC		103	61	49	40	1.7	10	TA211724.0873
0.3465			8.800	M10x1.25	3/8-16 UNC	103	61	49	40	1.7	10	TA211724.0880
0.3504			8.900	MJ10x1.25		103	61	49	40	1.7	10	TA211724.0890
0.3543			9.000	M10x1		103	61	49	40	1.7	10	TA211724.0900
0.3563			9.050		3/8-24 UNF	103	61	49	40	1.7	10	TA211724.0905
0.3583			9.100	1/8-27 NPSM		103	61	49	40	1.7	10	TA211724.0910
0.3594	23/64"		9.129			103	61	49	40	1.7	10	TA211724.0913
0.3622			9.200	M10x0.75		103	61	49	40	1.7	10	TA211724.0920
0.3661			9.300			103	61	49	40	1.7	10	TA211724.0930
0.3681			9.350		M10	103	61	49	40	1.8	10	TA211724.0935
0.3701			9.400	7/16-14 UNC		103	61	49	40	1.8	10	TA211724.0940
0.3720			9.450			103	61	49	40	1.8	10	TA211724.0945
0.3740			9.500	7/16-14 UNJC	STI-M10	103	61	49	40	1.8	10	TA211724.0950
0.3750	3/8"		9.525			103	61	49	40	1.8	10	TA211724.0953
0.3780			9.600		M10x1	103	61	49	40	1.8	10	TA211724.0960
0.3819			9.700	LK-UNC 7/16-14	M10x0.75	103	61	49	40	1.8	10	TA211724.0970
0.3858			9.800	STI 3/8-24		103	61	49	40	1.8	10	TA211724.0980
0.3898			9.900	7/16-20 UNF		103	61	49	40	1.9	10	TA211724.0990
0.3906	25/64"		9.921			103	61	49	40	1.9	10	TA211724.0992
0.3937			10.000	7/16-20 UNJF		103	61	49	40	1.9	10	TA211724.1000
0.3976			10.100			118	71	56	45	1.9	12	TA211724.1010
0.4016			10.200	7/16-28 UNEF		118	71	56	45	1.9	12	TA211724.1020
0.4035			10.250		7/16-14 UNC	118	71	56	45	1.9	12	TA211724.1025
0.4055			10.300			118	71	56	45	1.9	12	TA211724.1030
0.4063	13/32"		10.320			118	71	56	45	1.9	12	TA211724.1032
0.4075			10.350			118	71	56	45	1.9	12	TA211724.1035
0.4094			10.400			118	71	56	45	1.9	12	TA211724.1040
0.4134			10.500	M12x1.5		118	71	56	45	2.0	12	TA211724.1050
0.4154			10.550		7/16-20 UNF	118	71	56	45	2.0	12	TA211724.1055
0.4173			10.600			118	71	55	45	2.0	12	TA211724.1060
0.4213			10.700	LK-M12		118	71	56	45	2.0	12	TA211724.1070
0.4219	27/64"		10.716	1/2-13 UNC		118	71	56	45	2.0	12	TA211724.1072
0.4252			10.800	M12x1.25		118	71	56	45	2.0	12	TA211724.1080
0.4291			10.900	1/2-13 UNJC		118	71	56	45	2.0	12	TA211724.1090
0.4331			11.000	M12x1		118	71	56	45	2.1	12	TA211724.1100
0.4370			11.100	BSF 1/2-16		118	71	56	45	2.1	12	TA211724.1110



5 x D - Axial Coolant (continued)

- Special EMUGE coating and polishing process for high speed/long tool life
- Sub-micro grain carbide
- ALCR-89 Coating
- 2 Flutes with 30° Helix angle
- 140° drill point angle

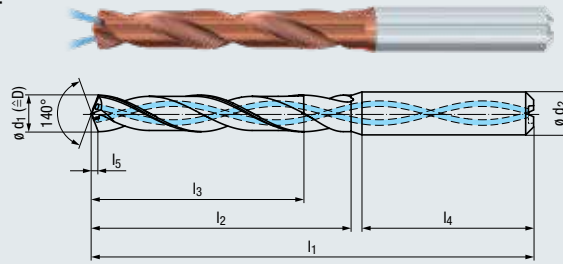

Applications - Materials

M	1.1-4.1
N	1.1-2.3
S	1.2-1.3, 2.2-2.3

Product Finder / Range of Applications and Material Descriptions (see pages 4-5)
Cutting Data (see pages 58-59)

Nominal Size Ø d ₁ m7 Tolerance				Taps	Roll Form Taps	mm					EDP No. HA SHANK	
Inch	Fraction	Wire letter	mm			l ₁	l ₂	l ₃	l ₄	l ₅		Ø d ₂ h6 Tol.
0.4375			11.113	LK-UNC 1/2-13		118	71	56	45	2.1	12	TA211724.1111
0.4409			11.200			118	71	56	45	2.1	12	TA211724.1120
0.4429			11.250	M12x0.75	M12	118	71	56	45	2.1	12	TA211724.1125
0.4449			11.300			118	71	56	45	2.1	12	TA211724.1130
0.4469			11.350		M12x1.5	118	71	56	45	2.1	12	TA211724.1135
0.4488			11.400	1/4-18 NPSC		118	71	56	45	2.1	12	TA211724.1140
0.4508			11.450		M12x1.25	118	71	56	45	2.1	12	TA211724.1145
0.4528			11.500	1/2-20 UNF		118	71	56	45	2.1	12	TA211724.1150
0.4531	29/64"		11.509			118	71	56	45	2.1	12	TA211724.1151
0.4567			11.600	1/2-20 UNJF	M12x1	118	71	56	45	2.2	12	TA211724.1160
0.4606			11.700			118	71	56	45	2.2	12	TA211724.1170
0.4646			11.800	1/2-28 UNEF	1/2-13 UNC	118	71	56	45	2.2	12	TA211724.1180
0.4685			11.900			118	71	56	45	2.2	12	TA211724.1190
0.4688	15/32"		11.908			118	71	56	45	2.2	12	TA211724.1191
0.4724			12.000	M14		118	71	56	45	2.2	12	TA211724.1200
0.4783			12.150		1/2-20 UNF	124	77	60	45	2.2	14	TA211724.1215
0.4803			12.200	Tr14x2		124	77	60	45	2.3	14	TA211724.1220
0.4844	31/64"		12.304	9/16-12 UNC		124	77	60	45	2.3	14	TA211724.1230
0.4921			12.500	M14x1.5		124	77	60	45	2.3	14	TA211724.1250
0.4941			12.550		G 1/4-19	124	77	60	45	2.3	14	TA211724.1255
0.4961			12.600			124	77	60	45	2.3	14	TA211724.1260
0.5000	1/2"		12.700	LK-UNC 9/16-12		124	77	60	45	2.4	14	TA211724.1270
0.5039			12.800	M14x1.25		124	77	60	45	2.4	14	TA211724.1280
0.5118			13.000	9/16-18 UNJF		124	77	60	45	2.4	14	TA211724.1300
0.5157			13.100	STI-1/2-20	M14	124	77	60	45	2.4	14	TA211724.1310
0.5236			13.300	9/16-24 UNEF	9/16-12 UNC	124	77	60	45	2.5	14	TA211724.1330
0.5256			13.350		M14x1.5	124	77	60	45	2.5	14	TA211724.1335
0.5295			13.450		M14x1.25	124	77	60	45	2.5	14	TA211724.1345
0.5313	17/32"		13.495	5/8-11 UNC		124	77	60	45	2.5	14	TA211724.1349
0.5315			13.500			124	77	60	45	2.5	14	TA211724.1350
0.5354			13.600			124	77	60	45	2.5	14	TA211724.1360
0.5374			13.650	5/8-11 UNJC	9/16-18 UNF	124	77	60	45	2.5	14	TA211724.1365
0.5394			13.700			124	77	60	45	2.5	14	TA211724.1370
0.5433			13.800			124	77	60	45	2.6	14	TA211724.1380
0.5469	35/64"		13.891			124	77	60	45	2.6	14	TA211724.1389
0.5512			14.000	M16, M15x1		124	77	60	45	2.6	14	TA211724.1400
0.5551			14.100			133	83	63	48	2.6	16	TA211724.1410
0.5625	9/16"		14.290			133	83	63	48	2.6	16	TA211724.1429
0.5709			14.500	5/8-18 UNF		133	83	63	48	2.7	16	TA211724.1450
0.5748			14.600	5/8-18 UNJF	M15x1	133	83	63	48	2.7	16	TA211724.1460
0.5781	37/64"		14.684	3/8-18 NPSC		133	83	63	48	2.7	16	TA211724.1468
0.5827			14.800		5/8-11 UNC	133	83	63	48	2.7	16	TA211724.1480
0.5906			15.000	M16x1		133	83	63	48	2.8	16	TA211724.1500
0.5938	19/32"		15.083			133	83	63	48	2.8	16	TA211724.1508
0.5945			15.100		M16	133	83	63	48	2.8	16	TA211724.1510
0.6043			15.350			133	83	63	48	2.8	16	TA211724.1535
0.6102			15.500	M18		133	83	63	48	2.9	16	TA211724.1550
0.6142			15.600		M16x1	133	83	63	48	2.9	16	TA211724.1560
0.6250	5/8"		15.875			133	83	63	48	2.9	16	TA211724.1588
0.6299			16.000	M18x2		133	83	63	48	3.0	16	TA211724.1600
0.6406	41/64"		16.272			143	93	71	48	3.0	18	TA211724.1627
0.6496			16.500	STI-5/8-11		143	93	71	48	3.1	18	TA211724.1650
0.6563	21/32"		16.669	3/4-10 UNC		143	93	71	48	3.1	18	TA211724.1667
0.6693			17.000	M18x1		143	93	71	48	3.1	18	TA211724.1700
0.6875	11/16"		17.463			143	93	71	48	3.1	18	TA211724.1746
0.6890			17.500	3/4-16 UNF, M20		143	93	71	48	3.2	18	TA211724.1750
0.7087			18.000	M20x2, LK-M16		143	93	71	48	3.3	18	TA211724.1800
0.7500	3/4"		19.050			153	101	77	50	3.3	20	TA211724.1905

Micro Drill



EMUGE Solid Carbide Micro Drills achieve ideal results when machining challenging materials such as alloyed steel, stainless steel, cast iron and nickel. These drills are self-centering and operate at top end cutting speeds and the highest feed rates to ensure the best hole quality. A unique flute and point geometry combination ensures outstanding surface quality and excellent tool life.

EMUGE Micro Drills are coated with an ultra-thin TiAlN-T99 PVD applied surface coating that withstands high heat applications and promotes smooth chip evacuation, guaranteeing optimal cost-effectiveness when drilling small diameter holes.



6 x D Micro - Coolant Fed

- Specialized point geometry generates short chips and guarantees optimum performance
- Rolled heel flute design for maximum chip evacuation
- Multi-Layer TiAlN-T99 PVD coating for heat and wear resistance
- 140° drill point angle

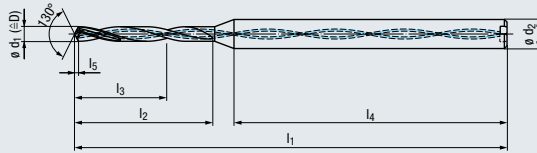

Applications - Materials

P	1.1-5.1
M	1.1-4.1
K	1.1-4.2
N	1.1-1.6, 2.2-2.3
S	1.2-1.3

Product Finder / Range of Applications and Material Descriptions (see pages 4-5)
 Cutting Data (see pages 60-61)
 Coolant Pressure / Flow Rate Recommendations (see page 66)

Nominal Size ø d ₁ k5 Tolerance		Taps	Roll Form Taps	mm					ø d ₂ h6 Tol.	EDP No. HA SHANK
Inch	mm			l ₁	l ₂	l ₃	l ₄	l ₅		
0.0295	0.75	M1		51.5	6.8	4.5	28	0.105	3	TE213324.0075
0.0315	0.80	M1x0.2		51.5	7.2	4.8	28	0.112	3	TE213324.0080
0.0335	0.85	M1.1		51.5	7.7	5.1	28	0.119	3	TE213324.0085
0.0354	0.90	M1.1x.2	M1	51.5	8.1	5.4	28	0.126	3	TE213324.0090
0.0374	0.95	M1.2		51.5	8.6	5.7	28	0.132	3	TE213324.0095
0.0394	1.00	M1.2x0.2	M1.1	55	9	6	28	0.139	4	TE213324.0100
0.0433	1.10	M1.4	M1.2	55	9.9	6.6	28	0.153	4	TE213324.0110
0.0472	1.20	M1.4x0.2		55	10.8	7.2	28	0.167	4	TE213324.0120
0.0492	1.25	M1.6		55	11.3	7.5	28	0.174	4	TE213324.0125
0.0504	1.28		M1.4	55	11.3	7.7	28	0.178	4	TE213324.0128
0.0512	1.30	MJ1.6x0.35		57	11.7	7.8	28	0.181	4	TE213324.0130
0.0531	1.35	M1.7		57	12.2	8.1	28	0.188	4	TE213324.0135
0.0551	1.40	M1.6x0.2		57	12.6	8.4	28	0.195	4	TE213324.0140
0.0571	1.45	M1.8		57	13	8.7	28	0.202	4	TE213324.0145
0.0579	1.47		M1.6	57	13	8.8	28	0.202	4	TE213324.0147
0.0591	1.50			57	13.5	9	28	0.209	4	TE213324.0150
0.0618	1.57		M1.7	59	14	9.4	28	0.219	4	TE213324.0157
0.0630	1.60	M2 / M1.8x0.2		59	14.4	9.6	28	0.223	4	TE213324.0160
0.0657	1.67		M1.8	59	14.9	10	28	0.233	4	TE213324.0167
0.0669	1.70			59	15.3	10.2	28	0.237	4	TE213324.0170
0.0689	1.75	M2.2 / M2x0.25		59	15.8	10.5	28	0.244	4	TE213324.0175
0.0709	1.80			61	16.2	10.8	28	0.251	4	TE213324.0180
0.0728	1.85		M2	61	16.7	11.1	28	0.258	4	TE213324.0185
0.0748	1.90	M2.3	M2x0.25	61	17.1	11.4	28	0.265	4	TE213324.0190
0.0768	1.95	M2.2x0.25 / M2.3x0.35		61	17.6	11.7	28	0.272	4	TE213324.0195
0.0787	2.00			63	18	12	28	0.279	4	TE213324.0200
0.0799	2.03		M2.2	63	18	12.2	28	0.283	4	TE213324.0203
0.0807	2.05	M2.5 / M2.3x0.25		63	18.5	12.3	28	0.286	4	TE213324.0205
0.0827	2.10	MJ2.5x0.45	M2.2x0.25	63	18.9	12.6	28	0.293	4	TE213324.0210
0.0846	2.15	M2.6 / M2.5x0.35	M2.3	63	19.4	12.9	28	0.300	4	TE213324.0215
0.0866	2.20		M2.3x0.25	63	19.8	13.2	28	0.307	4	TE213324.0220
0.0906	2.30			65	20.7	13.8	28	0.321	4	TE213324.0230
0.0917	2.33		M2.5	65	21.2	14	28	0.325	4	TE213324.0233
0.0945	2.40		M2.5x0.25	65	21.6	14.4	28	0.335	4	TE213324.0240
0.0957	2.43		M2.6	65	21.6	14.6	28	0.339	4	TE213324.0243
0.0984	2.50	M3	M2.6x0.25	65	22.5	15	28	0.349	4	TE213324.0250
0.1003	2.55			65	20	15.3	28	0.356	4	TE213324.0255
0.1024	2.60	MJ3x0.5		66.5	23.4	15.6	28	0.363	4	TE213324.0260
0.1043	2.65	M3x0.35		66.5	23.9	15.9	28	0.370	4	TE213324.0265
0.1063	2.70			66.5	24.3	16.2	28	0.377	4	TE213324.0270
0.1102	2.80	#6-32	M3	68.5	25.2	16.8	28	0.390	4	TE213324.0280
0.1142	2.90	M3.5	M3x0.25	68.5	26.1	17.4	28	0.404	4	TE213324.0290
0.1181	3.00	M3.5x0.5 / MJ3.5x0.6		73	27	18	36	0.418	4	TE213324.0300

EF-C Step Drill



EMUGE EF-C Step Drills are high performance carbide step drills that are available **from stock** in various step lengths and with the exact diameter required for pre-drilling tapped holes. These tools are designed specifically for users to produce drilled holes with a 90° chamfer in one operation. The EF-C Step Drill is a high penetration rate drill that creates short, consistent chip formations in a wide range of materials.

The unique characteristic of these coolant-fed, double-margin drills is that the stocked minor diameter on the step is available in industry standard sizes for both cut and formed tapped threads in UNC / UNF / Metric / and Metric-Fine profiles.

Most drills sizes are offered with 4 to 5 different step lengths, from stock, or are available in less than 4 weeks from the receipt of the order. Drills can be purchased in quantities from 1 to 20 at the same price and there is no need to purchase months of inventory to attain best pricing. Use the easy on-line stock check feature on the following page to see what is available from stock and ready to ship today!

EF-C Step Drill - Coolant Fed

Variable step length in millimeter steps

- Sub-micro grain carbide
- Axial coolant fed design
- TIALN-T14 coated for additional tool life
- 140° drill point angle
- Double-margin flute design on minor step diameter
- 90° included chamfer angle

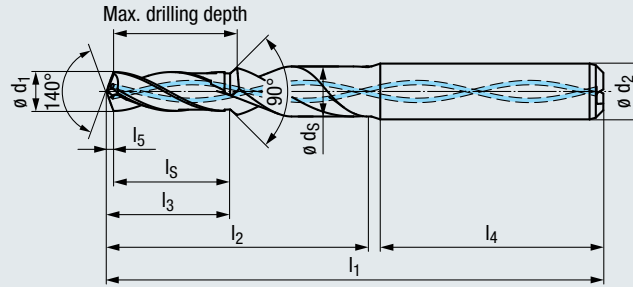

Applications - Materials

P	1.1-5.1
M	1.1
K	1.1-4.2
N	1.1-1.5, 2.1-2.8
S	2.2-2.3
H	1.1-1.2

Product Finder / Range of Applications and Material Descriptions (see pages 4-5)

Cutting Data (see pages 52-53)

Drill diameter ø d ₁ m7 Tolerance	Taps	Roll Form Taps	mm							Step length l _s		ø d ₂ h6 Tol.	EDP Nos. Ranges HA SHANK ** See below for example for how to create a part number.	
			ø d _s	l ₁	l ₂	l ₃		l ₄	l ₅	2 x D min.	3.5 x D max.			
0.1102	2.80	#6-32 UNC	M3	4	57	17	6.6 - 10.6		36	0.6	6 - 10		6	TG203344.028006 - TG203344.028010
0.1142	2.90	#6-32 UNJC	#5-40 UNC	4	57	18	6.6 - 10.6		36	0.6	6 - 10		6	TG203344.029006 - TG203344.029010
0.1280	3.25		M3.5	5	62	24	7.7 - 11.7		36	0.6	7 - 11		6	TG203344.032507 - TG203344.032511
0.1299	3.30	M4		5	62	24	7.7 - 12.7		36	0.7	7 - 12		6	TG203344.033007 - TG203344.033012
0.1457	3.70	M4.5	M4	5	62	24	7.8 - 13.8		36	0.7	7 - 13		6	TG203344.037007 - TG203344.037013
0.1654	4.20	M5 / STI-M4	M4.5	6	66	29	8.9 - 15.9		36	0.8	8 - 15		6	TG203344.042008 - TG203344.042015
0.1831	4.65	#12-24 UNJC	M5	6	66	29	9.9 - 16.9		36	0.9	9 - 16		6	TG203344.046509 - TG203344.046516
0.1969	5.00	M6	#12-24 UNC	7	79	40	11.0 - 19.0		36	1.0	10 - 18		8	TG203344.050010 - TG203344.050018
0.2205	5.60	7/4-32 UNEF	M6	7	79	40	12.1 - 21.1		36	1.1	11 - 20		8	TG203344.056011 - TG203344.056020
0.2362	6.00	M7 / Rd8x1/10		8	79	42	13.2 - 22.2		36	1.1	12 - 21		8	TG203344.060012 - TG203344.060021
0.2598	6.60	5/16-18 UNC	M7	8	89	45	14.3 - 24.3		40	1.3	13 - 23		10	TG203344.066013 - TG203344.066023
0.2677	6.80	M8 / G 7/16		9	89	46	15.4 - 25.4		40	1.3	14 - 24		10	TG203344.068014 - TG203344.068024
0.2756	7.00	5/16-24 UNJF		9	89	46	15.4 - 26.4		40	1.3	14 - 25		10	TG203344.070014 - TG203344.070025
0.2933	7.45		5/16-24 UNF / M8	9	89	46	16.5 - 27.5		40	1.4	15 - 26		10	TG203344.074515 - TG203344.074526
0.2992	7.60	Tr9x1.5	M8x1 / STI-M8	9	89	46	16.5 - 28.5		40	1.4	15 - 27		10	TG203344.076015 - TG203344.076027
0.3071	7.80	M9		10	89	48	17.5 - 28.5		40	1.5	16 - 27		10	TG203344.078016 - TG203344.078027
0.3327	8.45		M9	12	102	56	18.7 - 31.7		45	1.6	17 - 30		12	TG203344.084517 - TG203344.084530
0.3346	8.50	3/8-24 UNF / M10		12	102	56	18.7 - 31.7		45	1.6	17 - 30		12	TG203344.085017 - TG203344.085030
0.3543	9.00	M10x1		12	102	56	19.8 - 33.8		45	1.7	18 - 32		12	TG203344.090018 - TG203344.090032
0.3681	9.35		M10	12	102	56	20.8 - 34.8		45	1.8	19 - 33		12	TG203344.093519 - TG203344.093533
0.3740	9.50	7/16-14 UNJC	STI-M10	12	102	56	20.9 - 34.9		45	1.8	19 - 33		12	TG203344.095019 - TG203344.095033
0.3780	9.60		M10x1	12	102	56	20.9 - 35.9		45	1.8	19 - 34		12	TG203344.096019 - TG203344.096034
0.4016	10.20	7/16-28 UNEF		14	107	61	22.0 - 38.0		45	1.9	20 - 36		14	TG203344.102020 - TG203344.102036
0.4075	10.35			14	107	61	23.0 - 38.0		45	1.9	21 - 36		14	TG203344.103521 - TG203344.103536
0.4134	10.50	M12x1.5		14	107	61	23.1 - 39.1		45	2.0	21 - 37		14	TG203344.105021 - TG203344.105037
0.4429	11.25	M12x0.75	M12	14	107	61	25.2 - 41.2		45	2.1	23 - 39		14	TG203344.112523 - TG203344.112539
0.4469	11.35	Pg7	M12x1.5	14	107	61	25.2 - 42.2		45	2.1	23 - 40		14	TG203344.113523 - TG203344.113540
0.4724	12.00	M14		16	115	66	26.4 - 44.4		48	2.2	24 - 42		16	TG203344.120024 - TG203344.120042
0.4921	12.50	M14x1.5		16	115	66	27.4 - 46.4		48	2.3	25 - 44		16	TG203344.125025 - TG203344.125044
0.5157	13.10	STI-UNF 1/2-20	M14	16	115	66	28.6 - 48.6		48	2.4	26 - 46		16	TG203344.131026 - TG203344.131046
0.5256	13.35		M14x1.5	16	115	66	29.6 - 49.6		48	2.5	27 - 47		16	TG203344.133527 - TG203344.133547
0.5512	14.00	M16 / M15x1		18	123	74	30.7 - 51.7		48	2.6	28 - 49		18	TG203344.140028 - TG203344.140049
0.5709	14.50	5/8-18 UNF		18	123	74	31.8 - 53.8		48	2.7	29 - 51		18	TG203344.145029 - TG203344.145051
0.5945	15.10		M16	18	123	74	32.9 - 55.9		48	2.8	30 - 53		18	TG203344.151030 - TG203344.151053
0.6043	15.35			18	123	74	34.0 - 57.0		48	2.8	31 - 54		18	TG203344.153531 - TG203344.153554
0.6102	15.50	M18		20	131	80	34.0 - 57.0		50	2.9	31 - 54		20	TG203344.155031 - TG203344.155054



Scan code for:

Emuge's simple, fast, online step drill selection tool.

** Ordering Example: TG203344.0280 07

Drill diameter: d₁ = 2.80 mm

Step length l_s = 7mm

PunchDrill

Reduce Machining Forces and Optimize Chip-breaking

Time savings of 50% or more are possible with the new **EMUGE PunchDrill**, which offers high feed drilling that doubles the feed rate compared to standard drills without increasing the axial force or spindle speed. Suitable for machining cast aluminum alloys with at least 7% Si content, the EMUGE Punch Drill is available in drilling depth ranges up to approx. 8 x D, the nominal diameter range from 0.098" to 0.472" (2.5 mm to 12mm). Machining is done with a normal drilling cycle on CNC machines and cutting speeds and coolant pressures are similar to conventional drilling.



An **innovative chip breaker** enables short chips to control machining forces. **Newly developed surface treatments and a hard diamond-like coating (DLC)** specially designed for this application provide reliable chip removal and increase process reliability. When this high-feed tool is used at the recommended feed and speed of the series tool, machining time is halved (see example on opposite page). The increase of the feed at the same rotational speed results in a significant reduction of



machining time with less machine wear. The reduced power consumption of the machine saves money and also supports sustainability.

The primary advantages of PunchDrill are shorter machining times, fewer tool changes, and high

metal removal rates, in addition to higher productivity and saved resources. Despite the higher feed rate, tool life is comparable to conventional drills. The exceptional self-centering capability of the drill tip enables the best possible positioning accuracy on the holes. The EMUGE PunchDrill is also available as a step tool.

FEATURES:

- Machining of aluminium cast alloys with at least 7% Si content and magnesium alloys
- Drilling depth up to approx. 8 x D
- Nominal diameter range from 0.098" to 0.472" (2.5 mm to 12mm)
- Tool life comparable to conventional drills
- Step drilling is also possible
- Excellent centering capability leads to high positioning accuracy
- Machine with normal drilling cycles on CNC machines
- Patent-pending drill geometry
- Minimum quantity lubrication possible
- Cutting speeds and coolant pressures similar to conventional drills
- Unstable parts and work with unstable clamping can be drilled with greater process reliability.

*German engineered
EMUGE-FRANKEN quality*

Cutting data																
Diameter D ₁	in	0.113	0.158	0.165	0.236	0.197	0.220	0.236	0.268	0.276	0.291	0.315	0.335	0.366	0.441	0.472
	mm	3.3	4	4.2	4.6	5	5.6	6	6.8	7	7.4	8	8.5	9.3	11.2	12
Feed per revolution f	in/rev.	0.018	0.020	0.022	0.024	0.028	0.031	0.033	0.035	0.037	0.393	0.433	0.472	0.492	0.512	0.531
	mm/rev.	0.45	0.50	0.55	0.60	0.70	0.80	0.85	0.90	0.95	1.00	1.10	1.20	1.25	1.3	1.35
Cutting speed v _c	ft/min	656 - 984														
	m/min	200 - 300														
in the material groups N 1.5-1.6, 3.1-3.2 (Aluminum)																

Values are recommendations and can be increased if necessary depending on the application.



Scan
for more information
and video

Application example in aluminium cast alloys

Conventional HP Carbide Drill	
Diameter D_1	0.219" (5.55 mm)
Feed per revolution f	0.0158"/rev. (0.4 mm/rev.)
Speed n	15,000 rpm

PunchDrill	
Diameter D_1	0.219" (5.55 mm)
Feed per revolution f	0.0315"/rev. (0.8 mm/rev.)
Speed n	15,000 rpm

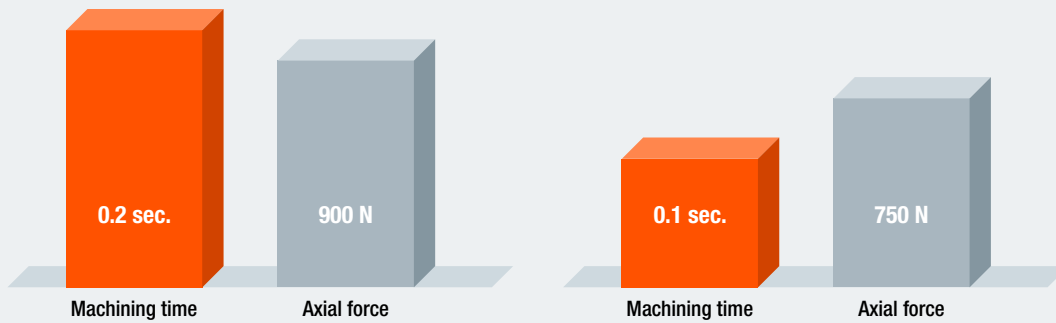

3 x D MultiDRILL

5 x D MultiDRILL

8 x D MultiDRILL

EF-C Step Drill



MultiDRILL
3 x D

MultiDRILL
5 x D

MultiDRILL
8 x D

EF-C Step Drill
2 X D - 3.5 x D

Cutting speed v_c [SFM]

min. rec. max. min. rec. max. min. rec. max. min. rec. max.

Steel materials													
P	1.1	328	459	591	328	459	591	328	459	591	459	525	656
	2.1	262	394	525	262	394	525	262	394	525	394	476	558
	3.1	262	328	394	262	328	394	197	262	394	328	394	459
	4.1	164	230	328	164	230	328	164	230	328	262	328	394
	5.1	164	213	295	164	213	295	164	213	295	197	230	262
Stainless Steel materials													
M	1.1	131	197	262	131	197	262	131	197	262	197	262	328
	2.1	131	180	246	131	180	246	131	180	246			
	3.1	131	164	230	131	164	230	131	164	230			
	4.1												
Cast materials													
K	1.1	394	459	525	394	459	525	394	459	525	427	525	623
	1.2	361	427	492	361	427	492	361	427	492	361	459	525
	2.1	459	525	591	459	525	591	459	525	591	361	459	558
	2.2	328	394	459	328	394	459	328	394	459	394	459	525
	3.1	262	328	394	262	328	394	262	328	394	230	295	328
	3.2	197	262	328	197	262	328	197	262	328	230	295	328
	4.1	328	394	459	328	394	459	328	394	459	394	459	525
	4.2	295	361	427	295	361	427	295	361	427	328	394	459
Non-ferrous materials													
Aluminum alloys													
N	1.1	525	591	787	525	591	787	525	591	787	722	853	919
	1.2	525	591	787	525	591	787	525	591	787	722	853	919
	1.3	525	591	787	525	591	787	525	591	787	656	755	853
	1.4	525	591	787	525	591	787	525	591	787	656	755	853
	1.5	525	591	787	525	591	787	525	591	787	541	607	656
	1.6	525	591	787	525	591	787	525	591	787			
Copper, Copper alloys, Bronze, Brass													
N	2.1	394	459	591	394	459	591	394	459	591	377	443	558
	2.2	394	459	591	394	459	591	394	459	591	525	574	623
	2.3	394	459	591	394	459	591	394	459	591	623	722	820
	2.4										312	295	361
	2.5										394	525	591
	2.6										377	377	427
	2.7										197	213	230
	2.8										213	230	246
Magnesium alloys													
3.1													
3.2													
Synthetics													
4.1													
4.2													
4.3													
4.4													
Special materials													
5.1													
5.2													
5.3													
Special materials													
Titanium alloys													
S	1.1	131	164	197	131	164	197	131	164	197			
	1.2	98	131	164	98	131	164	98	131	164			
	1.3												
Nickel alloys, cobalt alloys and iron alloys													
S	2.1												
	2.2	66	131	197	66	131	197	66	131	197	60	80	100
	2.3	33	82	131	33	82	131	33	82	131	50	65	80
	2.4												
	2.5												
	2.6												
Hard materials													
H	1.1	66	131	164	66	131	164	66	131	164	115	131	148
	1.2	66	98	164	66	98	164	66	98	164	98	115	131
	1.3	66	98	164	66	98	164	66	98	164			
	1.4												
	1.5												

3 x D, 5 x D, 8 x D MultiDRILL and EF-C Step Drill Cutting Data (Continued)

Please note that these data are standard values only.

- We recommend the standard values in bold print (**rec.**) for stable work conditions and for high-performance machine tools with sufficient speed capability.
- Correspondingly, the lower cutting speeds (**min.**) in connection with higher feed values (up to **max.**) should be used for machine tools with lower spindle speeds.
- For optimum workpiece conditions, and for machine tools with extremely high performance and high spindle speeds, the high cutting speeds (**max.**) in connection with possibly reduced feed values can be applied.

Formulas:

$$\text{RPM} = (\text{SFM}/\text{Dia. In.}) \times 3.82$$

$$\text{IPM} = \text{IPR} \times \text{RPM}$$

$$\text{m/min} = \text{SFM} \div 3.28$$

$$\text{mm/rev} = \text{IPR} \times 25.4$$

D = 3 mm			D = 5 mm			D = 8 mm			D = 10 mm			D = 12 mm			D = 16 mm			D = 18 mm				
D = 0.118 inch			D = 0.197 inch			D = 0.315 inch			D = 0.394 inch			D = 0.472 inch			D = 0.630 inch			D = 0.708 inch				
Feed per revolution f [inch/rev.]																						
min.	rec.	max.	min.	rec.	max.	min.	rec.	max.	min.	rec.	max.	min.	rec.	max.	min.	rec.	max.	min.	rec.	max.		
.0043	.0063	.0098	.0063	.0079	.0110	.0079	.0098	.0138	.0091	.0110	.0157	.0098	.0122	.0169	.0106	.0134	.0185	.0114	.0138	.0209	1.1	
.0043	.0063	.0098	.0063	.0079	.0110	.0079	.0098	.0138	.0091	.0110	.0157	.0098	.0122	.0169	.0106	.0134	.0185	.0114	.0138	.0209	2.1	
.0043	.0059	.0094	.0063	.0071	.0094	.0079	.0094	.0118	.0091	.0102	.0134	.0098	.0114	.0146	.0106	.0126	.0161	.0114	.0130	.0177	3.1	
.0043	.0059	.0094	.0063	.0071	.0094	.0079	.0094	.0118	.0091	.0102	.0134	.0098	.0114	.0146	.0106	.0126	.0161	.0114	.0130	.0177	4.1	
.0039	.0051	.0083	.0051	.0067	.0094	.0067	.0083	.0118	.0075	.0094	.0134	.0083	.0102	.0146	.0106	.0110	.0154	.0091	.0114	.0173	5.1	
.0016	.0024	.0035	.0035	.0047	.0075	.0043	.0067	.0102	.0055	.0075	.0118	.0059	.0083	.0130	.0063	.0091	.0142	.0067	.0094	.0146	1.1	
.0016	.0020	.0035	.0031	.0043	.0063	.0039	.0059	.0079	.0055	.0071	.0106	.0059	.0079	.0118	.0063	.0087	.0126	.0067	.0091	.0134	2.1	
.0016	.0020	.0031	.0031	.0043	.0063	.0039	.0059	.0079	.0055	.0071	.0106	.0059	.0079	.0118	.0063	.0087	.0126	.0067	.0091	.0134	3.1	
.0016	.0020	.0031	.0031	.0043	.0063	.0039	.0059	.0079	.0055	.0071	.0106	.0059	.0079	.0118	.0063	.0087	.0126	.0067	.0091	.0134	4.1	
.0043	.0063	.0098	.0063	.0079	.0110	.0079	.0098	.0138	.0091	.0110	.0157	.0098	.0122	.0169	.0106	.0134	.0185	.0114	.0138	.0197	1.1	
.0043	.0063	.0098	.0063	.0079	.0110	.0079	.0098	.0138	.0091	.0110	.0157	.0098	.0122	.0169	.0106	.0134	.0185	.0114	.0138	.0197	1.2	
.0043	.0063	.0098	.0063	.0079	.0110	.0079	.0098	.0138	.0091	.0110	.0157	.0098	.0122	.0169	.0106	.0134	.0185	.0114	.0138	.0213	2.1	
.0043	.0059	.0094	.0063	.0071	.0094	.0079	.0094	.0118	.0091	.0102	.0134	.0098	.0114	.0146	.0106	.0126	.0161	.0114	.0130	.0169	2.2	
.0043	.0063	.0098	.0063	.0079	.0110	.0079	.0098	.0138	.0091	.0110	.0157	.0098	.0122	.0169	.0106	.0134	.0185	.0114	.0138	.0197	3.1	
.0039	.0055	.0087	.0055	.0071	.0098	.0071	.0091	.0126	.0079	.0098	.0142	.0087	.0110	.0154	.0094	.0118	.0169	.0102	.0126	.0177	3.2	
.0043	.0063	.0098	.0063	.0079	.0110	.0079	.0098	.0138	.0091	.0110	.0157	.0098	.0122	.0169	.0106	.0134	.0185	.0114	.0138	.0197	4.1	
.0043	.0059	.0094	.0063	.0071	.0094	.0079	.0094	.0118	.0091	.0102	.0134	.0098	.0114	.0146	.0106	.0126	.0161	.0114	.0130	.0169	4.2	
.0055	.0075	.0122	.0075	.0110	.0150	.0094	.0130	.0165	.0106	.0146	.0185	.0118	.0161	.0205	.0126	.0177	.0224	.0130	.0181	.0228	1.1	
.0055	.0075	.0122	.0075	.0110	.0150	.0094	.0130	.0165	.0106	.0146	.0185	.0118	.0161	.0205	.0126	.0177	.0224	.0130	.0181	.0228	1.2	
.0055	.0075	.0122	.0075	.0110	.0150	.0094	.0130	.0165	.0106	.0146	.0185	.0118	.0161	.0205	.0126	.0177	.0224	.0130	.0181	.0228	1.3	
.0055	.0075	.0122	.0075	.0110	.0150	.0094	.0130	.0165	.0106	.0146	.0185	.0118	.0161	.0205	.0126	.0177	.0224	.0130	.0181	.0228	1.4	
.0055	.0075	.0122	.0075	.0110	.0150	.0094	.0130	.0165	.0106	.0146	.0185	.0118	.0161	.0205	.0126	.0177	.0224	.0130	.0181	.0228	1.5	
.0055	.0075	.0122	.0075	.0110	.0150	.0094	.0130	.0165	.0106	.0146	.0185	.0118	.0161	.0205	.0126	.0177	.0224	.0130	.0181	.0228	1.6	
.0012	.0020	.0028	.0016	.0024	.0031	.0020	.0039	.0051	.0024	.0047	.0055	.0024	.0055	.0063	.0028	.0059	.0067	.0028	.0063	.0067	2.1	
.0012	.0020	.0028	.0016	.0024	.0031	.0020	.0039	.0051	.0024	.0047	.0055	.0024	.0055	.0063	.0028	.0059	.0067	.0028	.0063	.0067	2.2	
.0043	.0055	.0075	.0067	.0087	.0118	.0087	.0110	.0154	.0098	.0122	.0165	.0106	.0130	.0173	.0118	.0142	.0189	.0122	.0146	.0197	2.3	
.0016	.0024	.0028	.0024	.0031	.0035	.0039	.0047	.0055	.0047	.0055	.0067	.0055	.0059	.0075	.0059	.0067	.0083	.0075	.0079	.0098	2.4	
.0020	.0028	.0035	.0028	.0039	.0047	.0047	.0059	.0067	.0055	.0067	.0079	.0067	.0079	.0087	.0075	.0083	.0102	.0087	.0098	.0114	2.5	
.0024	.0031	.0035	.0031	.0035	.0043	.0051	.0055	.0067	.0059	.0071	.0079	.0071	.0079	.0091	.0079	.0094	.0106	.0094	.0106	.0122	2.6	
.0012	.0012	.0016	.0012	.0016	.0024	.0028	.0031	.0035	.0031	.0035	.0039	.0035	.0039	.0047	.0039	.0047	.0055	.0055	.0059	.0067	2.7	
.0012	.0012	.0016	.0012	.0016	.0024	.0028	.0031	.0035	.0031	.0035	.0039	.0035	.0039	.0047	.0039	.0047	.0055	.0055	.0059	.0067	2.8	
																					3.1	
																						3.2
																						4.1
																						4.2
																						4.3
																						4.4
																						5.1
																						5.2
																						5.3
.0016	.0020	.0024	.0024	.0031	.0039	.0039	.0047	.0059	.0043	.0051	.0067	.0047	.0055	.0075	.0055	.0063	.0079	.0059	.0067	.0083	1.1	
.0016	.0020	.0024	.0024	.0031	.0039	.0039	.0047	.0059	.0043	.0051	.0067	.0047	.0055	.0075	.0055	.0063	.0079	.0059	.0067	.0083	1.2	
.0016	.0020	.0024	.0024	.0031	.0039	.0039	.0047	.0059	.0043	.0051	.0067	.0047	.0055	.0075	.0055	.0063	.0079	.0059	.0067	.0083	1.3	
.0016	.0020	.0024	.0016	.0031	.0043	.0039	.0051	.0079	.0043	.0059	.0091	.0047	.0067	.0098	.0055	.0071	.0106	.0059	.0075	.0110	2.1	
.0016	.0020	.0024	.0016	.0031	.0039	.0039	.0047	.0059	.0043	.0051	.0067	.0047	.0055	.0075	.0055	.0063	.0079	.0059	.0067	.0083	2.2	
																						2.3
																						2.4
																						2.5
																						2.6
.0020	.0024	.0043	.0031	.0043	.0063	.0039	.0063	.0098	.0043	.0071	.0110	.0047	.0075	.0122	.0055	.0079	.0134	.0059	.0083	.0138	1.1	
.0020	.0024	.0043	.0031	.0043	.0063	.0039	.0063	.0098	.0043	.0071	.0110	.0047	.0075	.0122	.0055	.0079	.0134	.0059	.0083	.0138	1.2	
.0020	.0024	.0043	.0031	.0043	.0063	.0039	.0063	.0098	.0043	.0071	.0110	.0047	.0075	.0122	.0055	.0079	.0134	.0059	.0083	.0138	1.3	
																						1.4
																						1.5

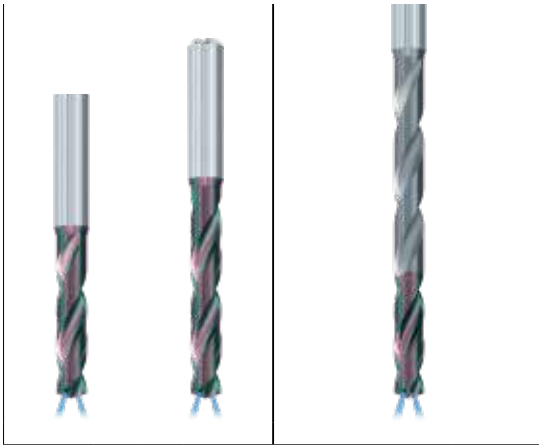

3 x D, 5 x D and 8 x D SteelDrill

Please note that these data are standard values only.

- We recommend the standard values in bold print (**rec.**) for stable work conditions and for high-performance machine tools with sufficient speed capability.
- Correspondingly, the lower cutting speeds (**min.**) in connection with higher feed values (up to **max.**) should be used for machine tools with lower spindle speeds.
- For optimum workpiece conditions, and for machine tools with extremely high performance and high spindle speeds, the high cutting speeds (**max.**) in connection with possibly reduced feed values can be applied.

	SteelDrill 3 x D			SteelDrill 5 x D			SteelDrill 8 x D			D = 3 mm D = 0.118 inch			D = 5 mm D = 0.197 inch			D = 8 mm D = 0.315 inch		
	Vc [SFM]						Feed per revolution f [inch/rev.]											
	min.	rec.	max.	min.	rec.	max.	min.	rec.	max.	min.	rec.	max.	min.	rec.	max.			
Steel materials																		
P	1.1	328	459	591	328	459	591	.0043	.0063	.0098	.0063	.0079	.0110	.0079	.0098	.0138		
	2.1	262	394	525	262	394	525	.0043	.0063	.0098	.0063	.0079	.0110	.0079	.0098	.0138		
	3.1	197	262	394	197	262	394	.0043	.0059	.0094	.0063	.0071	.0094	.0079	.0094	.0118		
	4.1	164	262	328	164	230	328	.0043	.0059	.0094	.0063	.0071	.0094	.0079	.0094	.0118		
	5.1	164	246	295	164	213	295	.0039	.0051	.0083	.0051	.0067	.0094	.0067	.0083	.0118		
Stainless Steel materials																		
M	1.1																	
	2.1																	
	3.1																	
	4.1																	
Cast materials																		
K	1.1	443	509	574	394	459	525	.0043	.0063	.0098	.0063	.0079	.0110	.0079	.0098	.0138		
	1.2	410	476	541	361	427	492	.0043	.0063	.0098	.0063	.0079	.0110	.0079	.0098	.0138		
	2.1	509	574	640	459	525	591	.0043	.0063	.0098	.0063	.0079	.0110	.0079	.0098	.0138		
	2.2	377	443	509	328	394	459	.0043	.0059	.0094	.0063	.0071	.0094	.0079	.0094	.0118		
	3.1	312	377	443	262	328	394	.0043	.0063	.0098	.0063	.0079	.0110	.0079	.0098	.0138		
	3.2	246	312	377	197	262	328	.0039	.0055	.0087	.0055	.0071	.0098	.0071	.0091	.0126		
	4.1	377	443	509	328	394	459	.0043	.0059	.0094	.0063	.0071	.0094	.0079	.0094	.0118		
4.2	345	410	476	295	361	427	.0039	.0055	.0087	.0055	.0071	.0098	.0071	.0091	.0126			
Non-ferrous materials																		
Aluminum alloys																		
N	1.1			525	591	787	.0055	.0075	.0122	.0075	.0110	.0150	.0094	.0130	.0165			
	1.2			525	591	787	.0055	.0075	.0122	.0075	.0110	.0150	.0094	.0130	.0165			
	1.3			525	591	787	.0055	.0075	.0122	.0075	.0110	.0150	.0094	.0130	.0165			
	1.4			525	591	787	.0055	.0075	.0122	.0075	.0110	.0150	.0094	.0130	.0165			
	1.5			525	591	787	.0055	.0075	.0122	.0075	.0110	.0150	.0094	.0130	.0165			
	1.6			525	591	787	.0055	.0075	.0122	.0075	.0110	.0150	.0094	.0130	.0165			
Copper, Copper alloys, Bronze, Brass																		
N	2.1			394	459	591	.0012	.0020	.0028	.0016	.0024	.0031	.0020	.0039	.0051			
	2.2			394	459	591	.0012	.0020	.0028	.0016	.0024	.0031	.0020	.0039	.0051			
	2.3			394	459	591	.0043	.0055	.0075	.0067	.0087	.0118	.0087	.0110	.0154			
	2.4			197	262	312	.0016	.0024	.0028	.0024	.0031	.0035	.0039	.0047	.0055			
	2.5			361	459	525	.0020	.0028	.0035	.0028	.0039	.0047	.0047	.0059	.0067			
	2.6			295	328	377	.0024	.0031	.0035	.0031	.0035	.0043	.0051	.0055	.0067			
	2.7			164	180	197	.0012	.0012	.0016	.0012	.0016	.0024	.0028	.0031	.0035			
	2.8			180	197	213	.0012	.0012	.0016	.0012	.0016	.0024	.0028	.0031	.0035			
Magnesium alloys																		
3.1																		
3.2																		
Synthetics																		
4.1																		
4.2																		
4.3																		
4.4																		
Special materials																		
5.1																		
5.2																		
5.3																		
Special materials																		
Titanium alloys																		
S	1.1	131	164	197	131	164	197	.0016	.0020	.0024	.0024	.0031	.0039	.0039	.0047	.0059		
	1.2	98	131	164	98	131	164	.0016	.0020	.0024	.0024	.0031	.0039	.0039	.0047	.0059		
	1.3																	
Nickel alloys, cobalt alloys and iron alloys																		
S	2.1																	
	2.2	66	131	197	66	131	197	.0016	.0020	.0024	.0016	.0031	.0043	.0039	.0051	.0079		
	2.3	33	82	131	33	82	131	.0016	.0020	.0024	.0016	.0031	.0039	.0039	.0047	.0059		
	2.4																	
	2.5																	
	2.6																	
Hard materials																		
H	1.1	66	131	164	66	131	164	.0020	.0024	.0043	.0031	.0043	.0063	.0039	.0063	.0098		
	1.2	66	98	164	66	98	164	.0020	.0024	.0043	.0031	.0043	.0063	.0039	.0063	.0098		
	1.3	66	98	164	66	98	164	.0020	.0024	.0043	.0031	.0043	.0063	.0039	.0063	.0098		
	1.4																	
	1.5																	

3 x D, 5 x D and 8 x D SteelDrill (Continued)

Please note:

The cutting values listed in the respective columns are standard values which have to be adjusted to individual work conditions (material, lubrication, machine etc.).

Formulas:

RPM = (SFM/Dia. In.) x 3.82

IPM = IPR x RPM

m/min = SFM ÷ 3.28

mm/rev = IPR x 25.4

D = 10 mm D = 0.394 inch			D = 12 mm D = 0.472 inch			D = 16 mm D = 0.630 inch			D = 20 mm D = 0.787 inch			
Feed per revolution f [inch/rev.]												
min.	rec.	max.	min.	rec.	max.	min.	rec.	max.	min.	rec.	max.	
.0091	.0110	.0157	.0098	.0122	.0169	.0106	.0134	.0185	.0118	.0150	.0209	1.1
.0091	.0110	.0157	.0098	.0122	.0169	.0106	.0134	.0185	.0118	.0150	.0209	2.1
.0091	.0102	.0134	.0098	.0114	.0146	.0106	.0126	.0161	.0118	.0138	.0177	3.1
.0091	.0102	.0134	.0098	.0114	.0146	.0106	.0126	.0161	.0118	.0138	.0177	4.1
.0075	.0094	.0134	.0083	.0102	.0146	.0106	.0110	.0154	.0098	.0122	.0173	5.1
												1.1
												2.1
												3.1
												4.1
.0091	.0110	.0157	.0098	.0122	.0169	.0106	.0134	.0185	.0118	.0150	.0209	1.1
.0091	.0110	.0157	.0098	.0122	.0169	.0106	.0134	.0185	.0118	.0150	.0209	1.2
.0091	.0110	.0157	.0098	.0122	.0169	.0106	.0134	.0185	.0118	.0150	.0209	2.1
.0091	.0102	.0134	.0098	.0114	.0146	.0106	.0126	.0161	.0118	.0138	.0177	2.2
.0091	.0110	.0157	.0098	.0122	.0169	.0106	.0134	.0185	.0118	.0150	.0209	3.1
.0079	.0098	.0142	.0087	.0110	.0154	.0094	.0118	.0169	.0106	.0134	.0185	3.2
.0091	.0102	.0134	.0098	.0114	.0146	.0106	.0126	.0161	.0118	.0126	.0161	4.1
.0079	.0098	.0142	.0087	.0110	.0154	.0094	.0118	.0169	.0106	.0118	.0169	4.2
.0106	.0146	.0185	.0118	.0161	.0205	.0126	.0177	.0224	.0130	.0181	.0228	1.1
.0106	.0146	.0185	.0118	.0161	.0205	.0126	.0177	.0224	.0130	.0181	.0228	1.2
.0106	.0146	.0185	.0118	.0161	.0205	.0126	.0177	.0224	.0130	.0181	.0228	1.3
.0106	.0146	.0185	.0118	.0161	.0205	.0126	.0177	.0224	.0130	.0181	.0228	1.4
.0106	.0146	.0185	.0118	.0161	.0205	.0126	.0177	.0224	.0130	.0181	.0228	1.5
.0106	.0146	.0185	.0118	.0161	.0205	.0126	.0177	.0224	.0130	.0181	.0228	1.6
.0024	.0047	.0055	.0024	.0055	.0063	.0028	.0059	.0067	.0028	.0063	.0067	2.1
.0024	.0047	.0055	.0024	.0055	.0063	.0028	.0059	.0067	.0028	.0063	.0067	2.2
.0098	.0122	.0165	.0106	.0130	.0173	.0118	.0142	.0189	.0122	.0146	.0197	2.3
.0047	.0055	.0067	.0055	.0059	.0075	.0059	.0067	.0083	.0075	.0079	.0098	2.4
.0055	.0067	.0079	.0067	.0079	.0087	.0075	.0083	.0102	.0087	.0098	.0114	2.5
.0059	.0071	.0079	.0071	.0079	.0091	.0079	.0094	.0106	.0094	.0106	.0122	2.6
.0031	.0035	.0039	.0035	.0039	.0047	.0039	.0047	.0055	.0055	.0059	.0067	2.7
.0031	.0035	.0039	.0035	.0039	.0047	.0039	.0047	.0055	.0055	.0059	.0067	2.8
												3.1
												3.2
												4.1
												4.2
												4.3
												4.4
												5.1
												5.2
												5.3
.0043	.0051	.0067	.0047	.0055	.0075	.0055	.0063	.0079	.0063	.0071	.0087	1.1
.0043	.0051	.0067	.0047	.0055	.0075	.0055	.0063	.0079	.0063	.0071	.0087	1.2
												1.3
.0043	.0059	.0091	.0047	.0067	.0098	.0055	.0071	.0106	.0063	.0079	.0114	2.1
.0043	.0051	.0067	.0047	.0055	.0075	.0055	.0063	.0079	.0063	.0071	.0087	2.2
												2.3
												2.4
												2.5
												2.6
.0043	.0071	.0110	.0047	.0075	.0122	.0055	.0079	.0134	.0063	.0087	.0173	1.1
.0043	.0071	.0110	.0047	.0075	.0122	.0055	.0079	.0134	.0063	.0087	.0173	1.2
.0043	.0071	.0110	.0047	.0075	.0122	.0055	.0079	.0134	.0063	.0087	.0173	1.3
												1.4
												1.5



12 x D EF-Drill

Please note:

The cutting values listed in the respective columns are standard values which have to be adjusted to individual work conditions (material, lubrication, machine etc.).

Formulas:

$$\text{RPM} = (\text{SFM}/\text{Dia. In.}) \times 3.82$$

$$\text{IPM} = \text{IPR} \times \text{RPM}$$

$$\text{m/min} = \text{SFM} \div 3.28$$

$$\text{mm/rev} = \text{IPR} \times 25.4$$

EF-Drill 12 x D		D = 3 mm D = 0.118 inch			D = 5 mm D = 0.197 inch			D = 8 mm D = 0.315 inch			D = 10 mm D = 0.394 inch			D = 12 mm D = 0.472 inch			D = 16 mm D = 0.630 inch					
		Cutting speed v _c [SFM]			Feed per revolution f [inch/rev.]																	
		min.	rec.	max.	min.	rec.	max.	min.	rec.	max.	min.	rec.	max.	min.	rec.	max.	min.	rec.	max.			
Steel materials																						
P	1.1	262	230	394	.0028	.0035	.0043	.0047	.0055	.0063	.0063	.0071	.0079	.0071	.0079	.0087	.0079	.0087	.0094	.0091	.0098	.0106
	2.1	230	295	361	.0028	.0035	.0043	.0047	.0055	.0063	.0063	.0071	.0079	.0071	.0079	.0087	.0079	.0087	.0094	.0091	.0098	.0106
	3.1	197	262	328	.0031	.0039	.0047	.0043	.0051	.0059	.0071	.0079	.0087	.0075	.0083	.0091	.0083	.0091	.0098	.0102	.0110	.0118
	4.1	180	246	312	.0023	.0031	.0039	.0035	.0043	.0051	.0063	.0071	.0079	.0071	.0079	.0087	.0079	.0087	.0094	.0094	.0102	.0110
	5.1	1487	180	213	.0016	.0023	.0031	.0028	.0035	.0043	.0055	.0063	.0071	.0063	.0071	.0079	.0071	.0079	.0087	.0083	.0091	.0098
Stainless Steel materials																						
M	1.1	131	197	262	.0016	.0023	.0031	.0028	.0035	.0043	.0039	.0047	.0055	.0051	.0059	.0067	.0055	.0063	.0071	.0063	.0071	.0079
	2.1																					
	3.1																					
	4.1																					
Cast materials																						
K	1.1	377	459	541	.0039	.0047	.0055	.0067	.0075	.0083	.0102	.0110	.0118	.0121	.0130	.0138	.0134	.0142	.0150	.0161	.0169	.0177
	1.2	312	410	459	.0039	.0047	.0055	.0063	.0071	.0079	.0106	.0114	.0121	.0118	.0126	.0134	.0130	.0138	.0146	.0154	.0161	.0169
	2.1	312	410	492	.0043	.0051	.0059	.0067	.0075	.0083	.0098	.0106	.0114	.0114	.0121	.0130	.0126	.0134	.0142	.0150	.0157	.0165
	2.2	344	410	459	.0035	.0043	.0051	.0059	.0067	.0075	.0083	.0091	.0098	.0094	.0102	.0110	.0102	.0110	.0118	.0126	.0134	.0142
	3.1	230	295	361	.0039	.0047	.0055	.0063	.0071	.0079	.0094	.0102	.0110	.0102	.0110	.0118	.0114	.0121	.0130	.0138	.0146	.0154
	3.2	197	262	328	.0035	.0043	.0051	.0047	.0055	.0063	.0075	.0083	.0091	.0083	.0091	.0098	.0091	.0098	.0106	.0110	.0118	.0126
	4.1																					
4.2																						
Non-ferrous materials																						
Aluminum alloys																						
N	1.1																					
	1.2																					
	1.3																					
	1.4																					
	1.5																					
	1.6																					
	Copper, Copper alloys, Bronze, Brass																					
	2.1																					
	2.2																					
	2.3																					
	2.4																					
	2.5																					
	2.6																					
	2.7																					
	2.8																					
	Magnesium alloys																					
3.1																						
3.2																						
Synthetics																						
4.1																						
4.2																						
4.3																						
4.4																						
Special materials																						
5.1																						
5.2																						
5.3																						
Special materials																						
Titanium alloys																						
S	1.1																					
	1.2																					
	1.3																					
	Nickel alloys, cobalt alloys and iron alloys																					
	2.1																					
	2.2																					
	2.3																					
2.4																						
2.5																						
2.6																						
Hard materials																						
H	1.1	49	82	115	.0008	.0016	.0023	.0020	.0028	.0035	.0028	.0035	.0043	.0028	.0035	.0043	.0035	.0043	.0051	.0043	.0051	.0059
	1.2																					
	1.3																					
	1.4																					
	1.5																					



NC Spot Drills

Please note that these data are standard values only.

- We recommend the standard values in bold print (**rec.**) for stable work conditions and for high-performance machine tools with sufficient speed capability.
- Correspondingly, the lower cutting speeds (**min.**) in connection with higher feed values (up to **max.**) should be used for machine tools with lower spindle speeds.
- For optimum workpiece conditions, and for machine tools with extremely high performance and high spindle speeds, the high cutting speeds (**max.**) in connection with possibly reduced feed values can be applied.

		NC Spot / 90° / 120°					NC Spot / 142°					D ≤ 6 mm			D > 6 mm				
												D ≤ 1/4			D > 1/4				
		Cutting speed v _c [SFM]						Feed per revolution f [inch/rev.]											
		min.	rec.	max.	min.	rec.	max.	min.	rec.	max.	min.	rec.	max.	min.	rec.	max.	min.	rec.	max.
P	Steel materials																		
	1.1	197	230	279	328	394	459	.0020	.0028	.0035	.0031	.0039	.0047						
	2.1	164	197	230	279	328	377	.0020	.0028	.0035	.0031	.0039	.0047						
	3.1	131	164	197	230	279	328	.0020	.0028	.0035	.0031	.0039	.0047						
	4.1				197	230	262	.0020	.0024	.0028	.0031	.0035	.0039						
5.1				148	180	213	.0020	.0024	.0028	.0031	.0035	.0039							
M	Stainless Steel materials																		
	1.1	115	164	197	197	262	328	.0020	.0024	.0028	.0031	.0035	.0039						
	2.1	82	98	115	131	164	197	.0020	.0024	.0028	.0031	.0035	.0039						
	3.1				115	131	148	.0020	.0024	.0028	.0031	.0035	.0039						
	4.1																		
K	Cast materials																		
	1.1	230	295	361	394	492	591	.0020	.0039	.0059	.0031	.0047	.0063						
	1.2	197	262	295	328	427	492	.0020	.0039	.0059	.0031	.0047	.0063						
	2.1	197	262	312	328	427	525	.0020	.0031	.0043	.0031	.0043	.0055						
	2.2	197	230	279	328	394	459	.0020	.0031	.0043	.0031	.0043	.0055						
	3.1	131	164	180	230	262	295	.0020	.0028	.0035	.0031	.0039	.0047						
	3.2				230	262	295	.0020	.0028	.0035	.0031	.0039	.0047						
	4.1	213	262	295	361	427	492	.0020	.0031	.0043	.0031	.0043	.0055						
	4.2	180	213	262	295	361	427	.0020	.0031	.0043	.0031	.0043	.0055						
	N	Non-ferrous materials																	
Aluminum alloys																			
1.1		410	476	525	689	787	886	.0031	.0047	.0063	.0043	.0059	.0071						
1.2		410	476	525	689	787	886	.0031	.0047	.0063	.0043	.0059	.0071						
1.3		361	394	427	591	656	722	.0024	.0039	.0055	.0035	.0051	.0063						
1.4		361	394	427	591	656	722	.0031	.0047	.0063	.0043	.0059	.0071						
1.5		295	328	361	492	558	591	.0031	.0047	.0063	.0043	.0059	.0071						
1.6																			
Copper, Copper alloys, Bronze, Brass																			
2.1		213	262	312	361	427	525	.0024	.0031	.0039	.0035	.0043	.0051						
2.2		295	312	328	492	525	558	.0024	.0031	.0039	.0035	.0043	.0051						
2.3		361	410	476	591	689	787	.0031	.0039	.0047	.0043	.0051	.0059						
2.4		115	164	180	197	262	295	.0020	.0028	.0035	.0031	.0039	.0047						
2.5		180	213	279	295	361	459	.0020	.0028	.0035	.0031	.0039	.0047						
2.6		180	197	213	295	328	361	.0031	.0039	.0047	.0043	.0051	.0059						
2.7					164	180	197	.0020	.0028	.0035	.0031	.0039	.0047						
2.8					164	180	197	.0020	.0028	.0035	.0031	.0039	.0047						
Magnesium alloys																			
3.1		180	213	279	295	361	459	.0020	.0028	.0035	.0031	.0039	.0047						
3.2		115	164	180	197	262	295	.0020	.0028	.0035	.0031	.0039	.0047						
Synthetics																			
4.1	262	279	295	427	459	492	.0016	.0024	.0031	.0028	.0035	.0043							
4.2	295	312	328	492	525	558	.0016	.0024	.0031	.0028	.0035	.0043							
4.3																			
4.4																			
Special materials																			
5.1				230	295	394	.0024	.0031	.0039	.0035	.0043	.0051							
5.2																			
5.3																			
S	Special materials																		
	Titanium alloys																		
	1.1	82	98	115	131	164	197	.0020	.0024	.0028	.0031	.0035	.0039						
	1.2				82	131	164	.0020	.0024	.0028	.0031	.0035	.0039						
	1.3																		
	Nickel alloys, cobalt alloys and iron alloys																		
	2.1																		
	2.2	16	33	66	33	66	98	.0020	.0024	.0028	.0031	.0035	.0039						
	2.3																		
	2.4				98	148	180	.0020	.0024	.0028	.0031	.0035	.0039						
2.5																			
2.6				98	115	131	.0020	.0024	.0028	.0031	.0035	.0039							
H	Hard materials																		
	1.1				98	115	131	.0020	.0024	.0028	.0031	.0035	.0039						
	1.2																		
	1.3																		
	1.4																		
	1.5																		



3 x D and 5 x D InoxDrill

Please note that these data are standard values only.

- We recommend the standard values in bold print (**rec.**) for stable work conditions and for high-performance machine tools with sufficient speed capability.
- Correspondingly, the lower cutting speeds (**min.**) in connection with higher feed values (up to **max.**) should be used for machine tools with lower spindle speeds.
- For optimum workpiece conditions, and for machine tools with extremely high performance and high spindle speeds, the high cutting speeds (**max.**) in connection with possibly reduced feed values can be applied.

		InoxDrill 3 x D		InoxDrill 5 x D		D = 3 mm D = 0.118 inch			D = 5 mm D = 0.197 inch			D = 8 mm D = 0.315 inch		
		Vc [SFM]						Feed per revolution f [inch/rev.]						
		min.	rec.	max.	min.	rec.	max.	min.	rec.	max.	min.	rec.	max.	
Steel materials														
P	1.1													
	2.1													
	3.1													
	4.1													
	5.1													
Stainless Steel materials														
M	1.1	131	197	262	0.0016	0.0024	0.0035	0.0035	0.0047	0.0075	0.0043	0.0067	0.0102	
	2.1	131	180	246	0.0016	0.0020	0.0031	0.0031	0.0043	0.0063	0.0039	0.0059	0.0079	
	3.1	131	164	230	0.0016	0.0020	0.0031	0.0031	0.0043	0.0063	0.0039	0.0059	0.0079	
	4.1	98	131	197	0.0016	0.0020	0.0031	0.0031	0.0043	0.0063	0.0039	0.0059	0.0079	
Cast materials														
K	1.1													
	1.2													
	2.1													
	2.2													
	3.1													
	3.2													
	4.1													
	4.2													
Non-ferrous materials														
Aluminum alloys														
N	1.1	525	591	787	0.0055	0.0075	0.0122	0.0075	0.0110	0.0150	0.0094	0.0130	0.0165	
	1.2	525	591	787	0.0055	0.0075	0.0122	0.0075	0.0110	0.0150	0.0094	0.0130	0.0165	
	1.3	525	591	787	0.0055	0.0075	0.0122	0.0075	0.0110	0.0150	0.0094	0.0130	0.0165	
	1.4	525	591	787	0.0055	0.0075	0.0122	0.0075	0.0110	0.0150	0.0094	0.0130	0.0165	
	1.5	525	591	787	0.0055	0.0075	0.0122	0.0075	0.0110	0.0150	0.0094	0.0130	0.0165	
	1.6	525	591	787	0.0055	0.0075	0.0122	0.0075	0.0110	0.0150	0.0094	0.0130	0.0165	
Copper, Copper alloys, Bronze, Brass														
N	2.1	394	459	591	0.0012	0.0020	0.0028	0.0016	0.0024	0.0031	0.0020	0.0039	0.0051	
	2.2	394	459	591	0.0012	0.0020	0.0028	0.0016	0.0024	0.0031	0.0020	0.0039	0.0051	
	2.3	394	459	591	0.0043	0.0055	0.0075	0.0067	0.0087	0.0118	0.0087	0.0110	0.0154	
	2.4													
	2.5													
	2.6													
	2.7													
	2.8													
Magnesium alloys														
N	3.1													
	3.2													
Synthetics														
N	4.1													
	4.2													
	4.3													
	4.4													
Special materials														
N	5.1													
	5.2													
	5.3													
Special materials														
Titanium alloys														
S	1.1													
	1.2	131	164	197	0.0016	0.0020	0.0024	0.0024	0.0031	0.0039	0.0039	0.0047	0.0059	
	1.3	98	131	164	0.0016	0.0020	0.0024	0.0024	0.0031	0.0039	0.0039	0.0047	0.0059	
Nickel alloys, cobalt alloys and iron alloys														
S	2.1													
	2.2	66	131	197	0.0016	0.0020	0.0024	0.0016	0.0031	0.0043	0.0039	0.0051	0.0079	
	2.3	33	82	131	0.0016	0.0020	0.0024	0.0016	0.0031	0.0039	0.0039	0.0047	0.0059	
	2.4													
	2.5													
	2.6													
Hard materials														
H	1.1													
	1.2													
	1.3													
	1.4													
	1.5													

3 x D and 5 x D InoxDrill (Continued)

Please note:

The cutting values listed in the respective columns are standard values which have to be adjusted to individual work conditions (material, lubrication, machine etc.).

Formulas:

RPM = (SFM/Dia. In.) x 3.82

IPM = IPR x RPM

m/min = SFM ÷ 3.28

mm/rev = IPR x 25.4

		D = 10 mm D = 0.394 inch			D = 12 mm D = 0.472 inch			D = 16 mm D = 0.630 inch			D = 20 mm D = 0.787 inch				
														Feed per revolution f [inch/rev.]	
		min.	rec.	max.	min.	rec.	max.	min.	rec.	max.	min.	rec.	max.		
														1.1	P
														2.1	
														3.1	
														4.1	
														5.1	
														1.1	M
0.0055	0.0075	0.0118	0.0059	0.0083	0.0130	0.0063	0.0091	0.0142	0.0071	0.0098	0.0150	1.1			
0.0055	0.0071	0.0106	0.0059	0.0079	0.0118	0.0063	0.0087	0.0134	0.0071	0.0094	0.0134	2.1			
0.0055	0.0071	0.0106	0.0059	0.0079	0.0118	0.0063	0.0087	0.0134	0.0071	0.0094	0.0134	3.1			
0.0055	0.0071	0.0106	0.0055	0.0079	0.0118	0.0063	0.0087	0.0134	0.0071	0.0094	0.0134	4.1			
														1.1	K
														1.2	
														2.1	
														2.2	
														3.1	
														3.2	
														4.1	
														4.2	
														1.1	N
0.0106	0.0146	0.0185	0.0118	0.0161	0.0205	0.0126	0.0177	0.0224	0.0134	0.0185	0.0232	1.1			
0.0106	0.0146	0.0185	0.0118	0.0161	0.0205	0.0126	0.0177	0.0224	0.0134	0.0185	0.0232	1.2			
0.0106	0.0146	0.0185	0.0118	0.0161	0.0205	0.0126	0.0177	0.0224	0.0134	0.0185	0.0232	1.3			
0.0106	0.0146	0.0185	0.0118	0.0161	0.0205	0.0126	0.0177	0.0224	0.0134	0.0185	0.0232	1.4			
0.0106	0.0146	0.0185	0.0118	0.0161	0.0205	0.0126	0.0177	0.0224	0.0134	0.0185	0.0232	1.5			
0.0106	0.0146	0.0185	0.0118	0.0161	0.0205	0.0126	0.0177	0.0224	0.0134	0.0185	0.0232	1.6			
														2.1	
0.0024	0.0047	0.0055	0.0024	0.0055	0.0063	0.0028	0.0059	0.0067	0.0035	0.0071	0.0079	2.1			
0.0024	0.0047	0.0055	0.0024	0.0055	0.0063	0.0028	0.0059	0.0067	0.0035	0.0071	0.0079	2.2			
0.0098	0.0122	0.0165	0.0106	0.0130	0.0173	0.0118	0.0142	0.0189	0.0130	0.0154	0.0201	2.3			
														2.4	
														2.5	
														2.6	
														2.7	
														2.8	
														3.1	
														3.2	
														4.1	
														4.2	
														4.3	
														4.4	
														5.1	
														5.2	
														5.3	
														1.1	S
0.0043	0.0051	0.0067	0.0047	0.0055	0.0075	0.0055	0.0063	0.0079	0.0063	0.0315	0.0087	1.1			
0.0043	0.0051	0.0067	0.0047	0.0055	0.0075	0.0055	0.0063	0.0079	0.0063	0.0071	0.0087	1.2			
														1.3	
														2.1	
0.0043	0.0059	0.0091	0.0047	0.0067	0.0098	0.0055	0.0071	0.0106	0.0063	0.0079	0.0114	2.1			
0.0043	0.0051	0.0067	0.0047	0.0055	0.0075	0.0055	0.0063	0.0079	0.0063	0.0071	0.0087	2.2			
														2.3	
														2.4	
														2.5	
														2.6	
														1.1	H
														1.2	
														1.3	
														1.4	
														1.5	



Micro Drill

Please note that these data are standard values only.

- We recommend the standard values in bold print (**rec.**) for stable work conditions and for high-performance machine tools with sufficient speed capability.
- Correspondingly, the lower cutting speeds (**min.**) in connection with higher feed values (up to **max.**) should be used for machine tools with lower spindle speeds.
- For optimum workpiece conditions, and for machine tools with extremely high performance and high spindle speeds, the high cutting speeds (**max.**) in connection with possibly reduced feed values can be applied.

Micro Drill				D = 0.8 mm			D = 1 mm			D = 1.25 mm			D = 1.5 mm			D = 2 mm			D = 2.5 mm			
6 x D				D = 0.031 inch			D = 0.039 inch			D = 0.049 inch			D = 0.059 inch			D = 0.079 inch			D = 0.098 inch			
Cutting speed v _c [SFM]				Feed per revolution f [inch/rev.]																		
min. rec. max.				min. rec. max.			min. rec. max.			min. rec. max.			min. rec. max.			min. rec. max.			min. rec. max.			
Steel materials																						
P	1.1	262	295	328	.0008	.0010	.0012	.0012	.0014	.0016	.0016	.0018	.0020	.0024	.0026	.0028	.0035	.0039	.0043	.0047	.0051	.0055
	2.1	230	279	328	.0008	.0010	.0012	.0012	.0014	.0016	.0016	.0018	.0020	.0024	.0026	.0028	.0035	.0039	.0043	.0047	.0051	.0055
	3.1	197	213	230	.0004	.0006	.0008	.0008	.0010	.0012	.0012	.0014	.0016	.0016	.0018	.0020	.0024	.0026	.0028	.0031	.0033	.0035
	4.1	164	180	197	.0004	.0006	.0008	.0008	.0010	.0012	.0012	.0014	.0016	.0016	.0018	.0020	.0024	.0026	.0028	.0031	.0033	.0035
	5.1	148	164	180	.0004	.0006	.0008	.0008	.0010	.0012	.0012	.0014	.0016	.0016	.0018	.0020	.0024	.0026	.0028	.0031	.0033	.0035
Stainless Steel materials																						
M	1.1	131	157	180	.0002	.0003	.0004	.0004	.0005	.0006	.0008	.0009	.0010	.0012	.0014	.0016	.0020	.0022	.0024	.0024	.0026	.0028
	2.1	98	115	131	.0004	.0006	.0008	.0006	.0008	.0010	.0010	.0012	.0014	.0014	.0017	.0020	.0022	.0025	.0028	.0026	.0029	.0031
	3.1	98	115	131	.0002	.0003	.0004	.0004	.0005	.0006	.0008	.0009	.0010	.0012	.0014	.0016	.0020	.0022	.0024	.0024	.0026	.0028
	4.1	98	115	131	.0002	.0003	.0004	.0004	.0005	.0006	.0008	.0009	.0010	.0012	.0014	.0016	.0020	.0022	.0024	.0024	.0026	.0028
Cast materials																						
K	1.1	394	476	558	.0008	.0010	.0012	.0016	.0020	.0024	.0024	.0028	.0031	.0031	.0035	.0039	.0039	.0043	.0047	.0051	.0055	.0059
	1.2	394	476	558	.0008	.0010	.0012	.0016	.0020	.0024	.0024	.0028	.0031	.0031	.0035	.0039	.0039	.0043	.0047	.0051	.0055	.0059
	2.1	394	443	492	.0008	.0010	.0012	.0016	.0020	.0024	.0024	.0028	.0031	.0031	.0035	.0039	.0039	.0043	.0047	.0051	.0055	.0059
	2.2	295	344	394	.0004	.0006	.0008	.0012	.0016	.0020	.0020	.0024	.0028	.0028	.0031	.0035	.0035	.0039	.0043	.0047	.0051	.0055
	3.1	197	230	262	.0008	.0010	.0012	.0012	.0016	.0020	.0016	.0020	.0024	.0020	.0024	.0028	.0028	.0031	.0035	.0035	.0039	.0043
	3.2	197	230	262	.0004	.0006	.0008	.0008	.0012	.0016	.0012	.0016	.0020	.0016	.0020	.0024	.0020	.0024	.0028	.0024	.0030	.0035
	4.1	197	230	262	.0008	.0010	.0012	.0012	.0016	.0020	.0016	.0020	.0024	.0020	.0024	.0028	.0028	.0031	.0035	.0035	.0039	.0043
4.2	197	230	262	.0004	.0006	.0008	.0008	.0012	.0016	.0012	.0016	.0020	.0016	.0020	.0024	.0020	.0024	.0028	.0024	.0030	.0035	
Non-ferrous materials																						
Aluminum alloys																						
N	1.1	328	459	591	.0012	.0014	.0016	.0016	.0018	.0020	.0020	.0022	.0024	.0028	.0030	.0031	.0039	.0043	.0047	.0051	.0055	.0059
	1.2	328	459	591	.0012	.0014	.0016	.0016	.0018	.0020	.0020	.0022	.0024	.0028	.0030	.0031	.0039	.0043	.0047	.0051	.0055	.0059
	1.3	328	459	591	.0012	.0014	.0016	.0016	.0018	.0020	.0020	.0022	.0024	.0028	.0030	.0031	.0039	.0043	.0047	.0051	.0055	.0059
	1.4	262	377	492	.0012	.0014	.0016	.0016	.0018	.0020	.0020	.0022	.0024	.0028	.0030	.0031	.0039	.0043	.0047	.0051	.0055	.0059
	1.5	262	377	492	.0008	.0010	.0012	.0012	.0014	.0016	.0016	.0018	.0020	.0024	.0026	.0028	.0035	.0039	.0043	.0047	.0051	.0055
	1.6	262	377	492	.0008	.0010	.0012	.0012	.0014	.0016	.0016	.0018	.0020	.0024	.0026	.0028	.0035	.0039	.0043	.0047	.0051	.0055
	2.1	394	443	492	.0004	.0008	.0012	.0008	.0012	.0016	.0012	.0016	.0020	.0020	.0024	.0028	.0031	.0037	.0043	.0043	.0049	.0055
2.3	394	443	492	.0004	.0008	.0012	.0008	.0012	.0016	.0012	.0016	.0020	.0020	.0024	.0028	.0031	.0037	.0043	.0043	.0049	.0055	
2.4																						
2.5																						
2.6																						
2.7																						
2.8																						
Magnesium alloys																						
3.1																						
3.2																						
Synthetics																						
4.1																						
4.2																						
4.3																						
4.4																						
Special materials																						
5.1																						
5.2																						
5.3																						
Special materials																						
Titanium alloys																						
S	1.1																					
	1.2	66	82	98	.0004	.0006	.0008	.0004	.0006	.0008	.0010	.0012	.0014	.0012	.0016	.0020	.0016	.0020	.0024	.0022	.0026	.0030
	1.3	49	66	82	.0004	.0006	.0008	.0004	.0006	.0008	.0010	.0012	.0014	.0012	.0016	.0020	.0016	.0020	.0024	.0022	.0026	.0030
Nickel alloys, cobalt alloys and iron alloys																						
2.1																						
2.2																						
2.3																						
2.4																						
2.5																						
2.6																						
Hard materials																						
H	1.1																					
	1.2																					
	1.3																					
	1.4																					
	1.5																					

**Micro Drill
(Continued)**



MultiDrill Micro Drill

Please note:

The cutting values listed in the respective columns are standard values which have to be adjusted to individual work conditions (material, lubrication, machine etc.).

Formulas:

$$RPM = (SFM/Dia. \text{ In.}) \times 3.82$$

$$IPM = IPR \times RPM$$

$$m/min = SFM \div 3.28$$

$$mm/rev = IPR \times 25.4$$

D = 3 mm D = 0.118 inch			
Cutting speed v _c [SFM]			
min.	rec.	max.	
.0059	.0063	.0067	
.0059	.0063	.0067	
.0047	.0049	.0051	
.0047	.0049	.0051	
.0047	.0049	.0051	
.0028	.0030	.0031	
.0030	.0033	.0035	
.0028	.0030	.0031	
.0028	.0030	.0031	
.0063	.0067	.0071	
.0063	.0067	.0071	
.0063	.0067	.0071	
.0059	.0063	.0067	
.0043	.0047	.0051	
.0031	.0037	.0043	
.0043	.0047	.0051	
.0031	.0037	.0043	
.0026	.0030	.0033	
.0026	.0030	.0033	

MultiDrill Micro Drill 6 x D		D = 1 mm - 1.49 mm D = 0.039 - 0.058 inch			D = 1.5 mm - 1.99 mm D = 0.059 - 0.078 inch			D = 2.0 - 2.49 mm D = 0.079 - 0.097 inch			D = 2.5 - 2.99 mm D = 0.098 - 0.117 inch					
		Cutting speed v _c [SFM]			Feed per revolution f [inch/rev.]											
			min.	rec.	max.	min.	rec.	max.	min.	rec.	max.	min.	rec.	max.		
Steel materials																
P	1.1	164	214	263	.0020	.0028	.0035	.0028	.0035	.0043	.0035	.0043	.0051	.0043	.0051	.0059
	2.1	148	181	214	.0020	.0028	.0035	.0028	.0035	.0043	.0035	.0043	.0051	.0043	.0051	.0059
	3.1	132	164	197	.0016	.0024	.0031	.0024	.0031	.0039	.0031	.0039	.0047	.0039	.0047	.0055
	4.1	99	132	164	.0016	.0024	.0031	.0024	.0031	.0039	.0031	.0039	.0047	.0039	.0047	.0055
	5.1	99	115	132	.0012	.0020	.0024	.0020	.0028	.0035	.0028	.0035	.0043	.0035	.0043	.0051
Stainless Steel materials																
M	1.1	99	132	164	.0010	.0012	.0016	.0012	.0020	.0028	.0020	.0028	.0035	.0028	.0035	.0043
	2.1	82	115	148	.0010	.0012	.0016	.0012	.0020	.0028	.0020	.0028	.0035	.0028	.0035	.0043
	3.1	82	115	148	.0010	.0012	.0016	.0012	.0020	.0028	.0020	.0028	.0035	.0028	.0035	.0043
	4.1	66	99	132	.0010	.0012	.0016	.0012	.0020	.0028	.0020	.0028	.0035	.0028	.0035	.0043
Cast materials																
K	1.1	263	296	329	.0024	.0031	.0039	.0031	.0039	.0047	.0039	.0047	.0055	.0047	.0055	.0063
	1.2	263	296	329	.0024	.0031	.0039	.0031	.0039	.0047	.0039	.0047	.0055	.0047	.0055	.0063
	2.1	263	296	329	.0024	.0031	.0039	.0031	.0039	.0047	.0039	.0047	.0055	.0047	.0055	.0063
	2.2	230	263	296	.0024	.0031	.0039	.0031	.0039	.0047	.0039	.0047	.0055	.0047	.0055	.0063
	3.1	263	296	329	.0024	.0031	.0039	.0031	.0039	.0047	.0039	.0047	.0055	.0047	.0055	.0063
	3.2	197	230	296	.0024	.0031	.0039	.0031	.0039	.0047	.0039	.0047	.0055	.0047	.0055	.0063
	4.1															
	4.2															
Non-ferrous materials																
Aluminum alloys																
N	1.1	329	427	526	.0016	.0024	.0031	.0024	.0031	.0039	.0031	.0039	.0047	.0039	.0047	.0055
	1.2	329	427	526	.0016	.0024	.0031	.0024	.0031	.0039	.0031	.0039	.0047	.0039	.0047	.0055
	1.3	329	427	526	.0016	.0024	.0031	.0024	.0031	.0039	.0031	.0039	.0047	.0039	.0047	.0055
	1.4	329	427	526	.0016	.0024	.0031	.0024	.0031	.0039	.0031	.0039	.0047	.0039	.0047	.0055
	1.5	329	427	526	.0016	.0024	.0031	.0024	.0031	.0039	.0031	.0039	.0047	.0039	.0047	.0055
	1.6	329	427	526	.0016	.0024	.0031	.0024	.0031	.0039	.0031	.0039	.0047	.0039	.0047	.0055
Copper, Copper alloys, Bronze, Brass																
N	2.1	263	362	460	.0118	.0016	.0024	.0016	.0024	.0031	.0024	.0031	.0039	.0031	.0039	.0047
	2.2	263	362	460	.0118	.0016	.0024	.0016	.0024	.0031	.0024	.0031	.0039	.0031	.0039	.0047
	2.3	263	362	460	.0016	.0024	.0031	.0024	.0031	.0039	.0031	.0039	.0047	.0039	.0047	.0055
	2.4															
	2.5															
	2.6															
	2.7															
	2.8															
Magnesium alloys																
N	3.1															
	3.2															
Synthetics																
N	4.1															
	4.2															
	4.3															
	4.4															
Special materials																
N	5.1															
	5.2															
	5.3															
Special materials																
Titanium alloys																
S	1.1															
	1.2	99	132	164	.0008	.0012	.0016	.0118	.0016	.0024	.0016	.0024	.0031	.0024	.0031	.0039
	1.3	66	99	132	.0008	.0012	.0016	.0118	.0016	.0024	.0016	.0024	.0031	.0024	.0031	.0039
Nickel alloys, cobalt alloys and iron alloys																
S	2.1															
	2.2	99	132	164	.0008	.0012	.0016	.0118	.0016	.0024	.0016	.0024	.0031	.0024	.0031	.0039
	2.3	66	82	132	.0008	.0012	.0016	.0118	.0016	.0024	.0016	.0024	.0031	.0024	.0031	.0039
	2.4															
	2.5															
	2.6															
Hard materials																
H	1.1	66	82	99	.0002	.0004	.0006	.0004	.0006	.0008	.0006	.0008	.0010	.0008	.0010	.0012
	1.2	66	82	99	.0002	.0004	.0006	.0003	.0004	.0005	.0005	.0006	.0006	.0008	.0010	.0012
	1.3															
	1.4															
	1.5															

Reduce feed on angled entry/exit surfaces

The EMUGE-FRANKEN double-margin design provides excellent guiding ability that is especially effective in work with transverse holes or angled exits.

The EMUGE-FRANKEN Drill self-centers primarily by means of the chisel edge. With slanted, concave, convex or very rough entry surfaces, the tool is being deflected. That is why feed must be reduced in the first drilling stage.

Angled entry surfaces

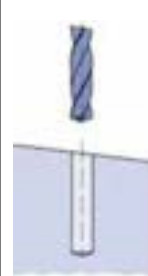

Feed must be reduced during the first drilling stage:

DIN 6537 short (3 x d1)

- 1...2°: **by 20%**
- 2...3°: **by 40%**
- 3...4°: **by 50%**
- 4...5°: **by 70%**

DIN 6537 long (5 x d1)

- < 1°: **by 30%**
- 1...2°: **by 40%**
- 2...3°: **by 50%**

Angled or rounded exit surfaces

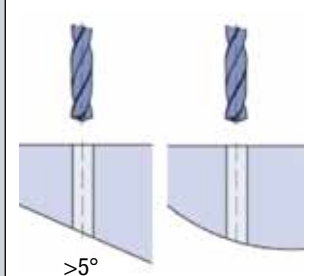

Feed must be reduced during the breaking through stage:

For Drills with double-margins
by 50%

>5°

Proper external coolant use

It is important to provide not only sufficient coolant-lubricant pressure, but also the right direction for the coolant-lubricant supply. Wherever possible, make arrangements for 3 coolant-lubricant jets to hit the drill.

Vertical machining

good

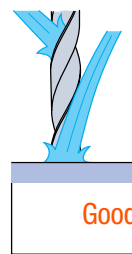

Good supply

better

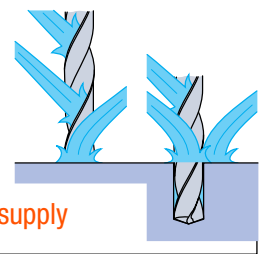

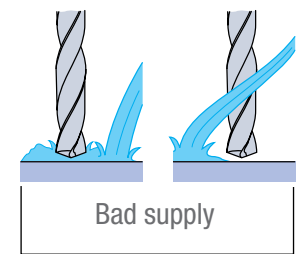

Bad supply

Horizontal machining

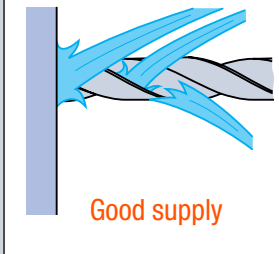

Good supply

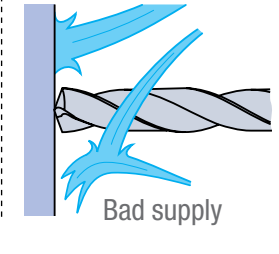

Bad supply

Proper edge preparation (honing)

Every drill has an edge preparation (hone) which is in relation to the drill diameter and material to be cut. The edge preparation is for stabilizing the cutting edge. The feed is in relation to the edge preparation and material.

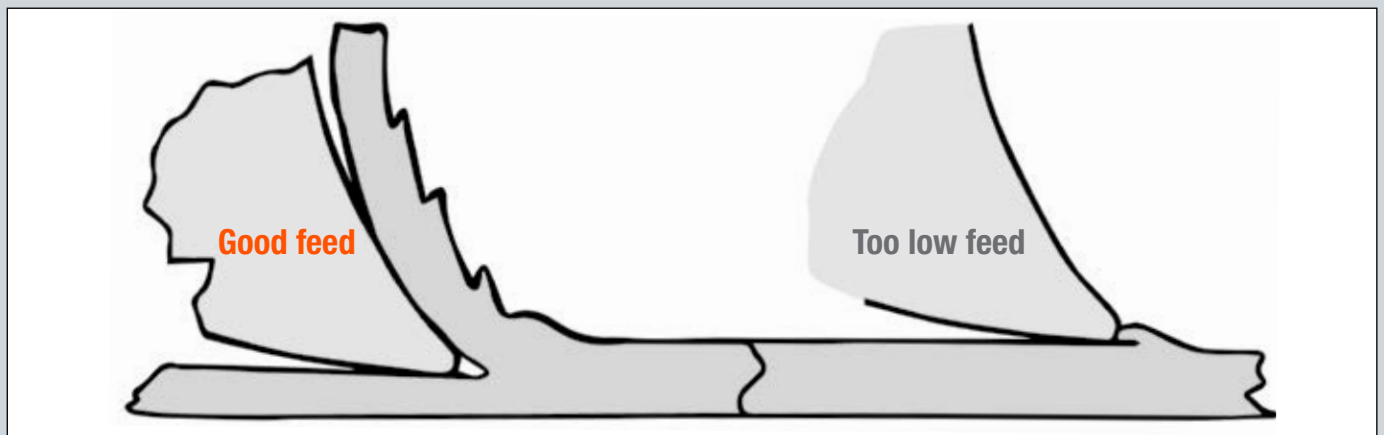

Point angle

Centering and pilot hole

With large clamping-related extension lengths, it is necessary to provide either a centering or a pilot hole. With tool lengths exceeding 8 x D, it is highly recommended to either start drilling with reduced feed, or to provide a centering or a pilot hole.

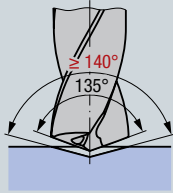

Centering / Spot Drilling

Please note that the point angle of the first, or preparatory drill must be larger than that of the subsequent drill. We recommend our Drill acc. DIN 6537 K. The centering should not be deeper than the point length l_5 .

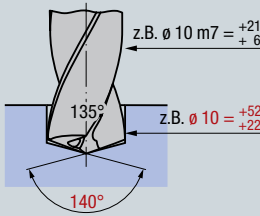

Pilot hole

Please note that the point angle and the diameter of the pilot drill must be larger than those of the subsequent drill. For the pilot hole, a depth of 1 x D is sufficient.

Influence of the point angle

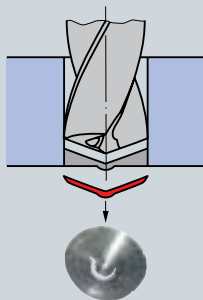

Standard point angle 140° (Drill)



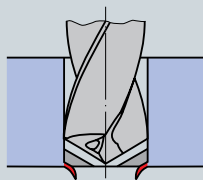





- Stable point
- Short chips
- Good centering
- Reduced power consumption
- Reduced torque
- Formation of material cap
- Minimal burr formation
- Long tool life

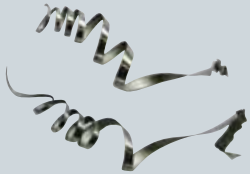

Point angle 118°

- Unstable point
- High torque
- High power consumption
- Unstable primary cutting edges
- Material cap formation very much reduced
- Formation of burr during the exit of the drill

Typical Chip Forms

	<p>Start-of-drilling chip This chip type is produced in the start of the drilling process, before the cutting corners are engaged.</p>
	<p>Optimal drilling chip This chip type is created when the cutting data are correctly chosen.</p>
	<p>Drill-through chip Note: There is need for increased space between workpiece and tool holder.</p>
	<p>Drill-through cap Note: There is need for increased space for chips and lid in drilling through!</p>
	<p>Chamfer chip This chip type is created in the production of the chamfer.</p>
	<p>Step-drill chip The length of this chip type can be controlled by means of dwell times in long-chipping material.</p>
	<p>Hooked chips These chips are produced especially in long-chipping materials, or when cutting data are not optimally chosen. Single entangled chips are not such a big issue, but when the entanglement of the chips becomes permanent it will soon lead to chip clogging and drill breakage.</p>
	<p>Ribbon chip / flow chip Note: When you observe this chip type, the drill already has serious damage on the primary cutting edge and chisel edge! This means an end to tool life.</p>

Tool clamping

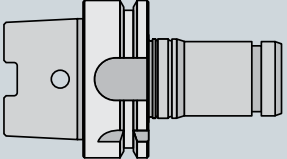
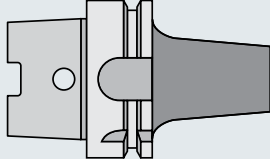
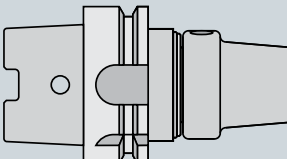
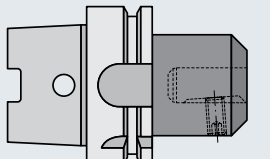
 <p>Collet holders type PGR Concentricity < 3 µm</p> <ul style="list-style-type: none"> • Slender construction • Reduced vibrations 	 <p>Shrink-fit chucks Concentricity < 3 µm</p> <ul style="list-style-type: none"> • Slender construction
 <p>Hydraulic expansion chucks Concentricity < 3 µm</p> <ul style="list-style-type: none"> • Reduced vibrations 	 <p>Tool holders for straight shanks with inclined clamping flat Concentricity < 15 µm</p> <ul style="list-style-type: none"> • Economically efficient

Differences in tool clamping with lateral driving flat and inclined clamping flat

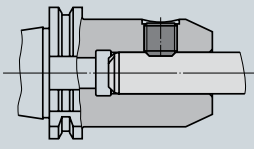
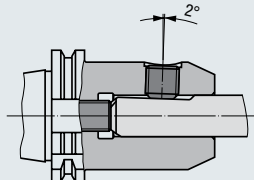
 <p>Lateral driving flat Clamping of tools with lateral driving flat acc. DIN 6535 HB resp. DIN 1835 B. This type of clamping has no axial support and is therefore not suitable for drilling operations.</p>	 <p>Inclined clamping flat Clamping of tools with inclined clamping flat acc. DIN 6535 HE resp. DIN 1835 E.</p>
---	---

Workpiece clamping

Solid carbide twist drills are extremely sensitive to bending stress!

Basic conditions for the use of twist drills:

- The workpiece must be firmly supported, without a chance to bounce or bend
- Additional support points will help
- With thin-walled workpieces, feed must be reduced

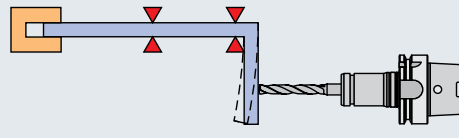
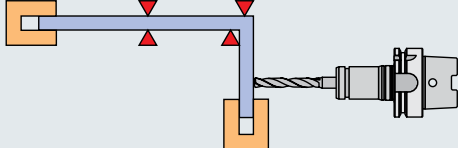
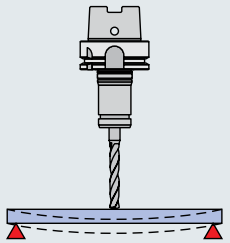
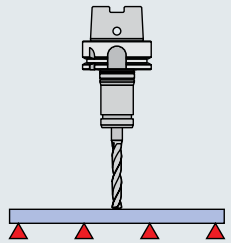
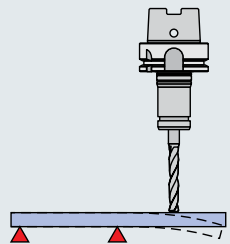
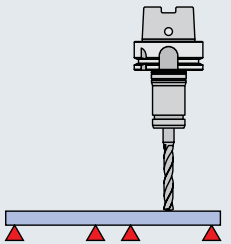
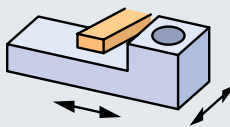
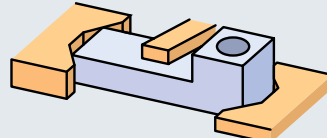
Wrong workpiece clamping	Correct workpiece clamping
	
	
	
	

Micro Drill Technical information

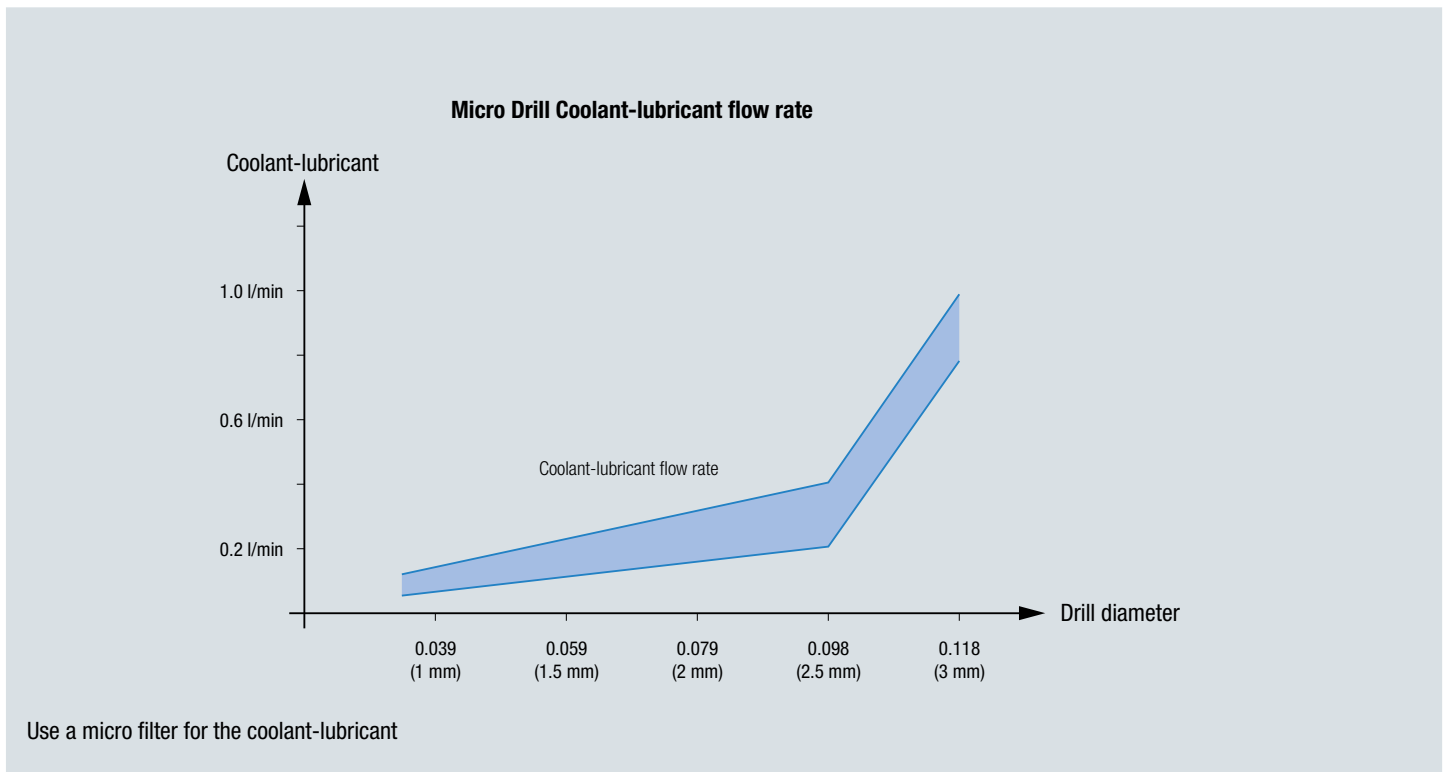
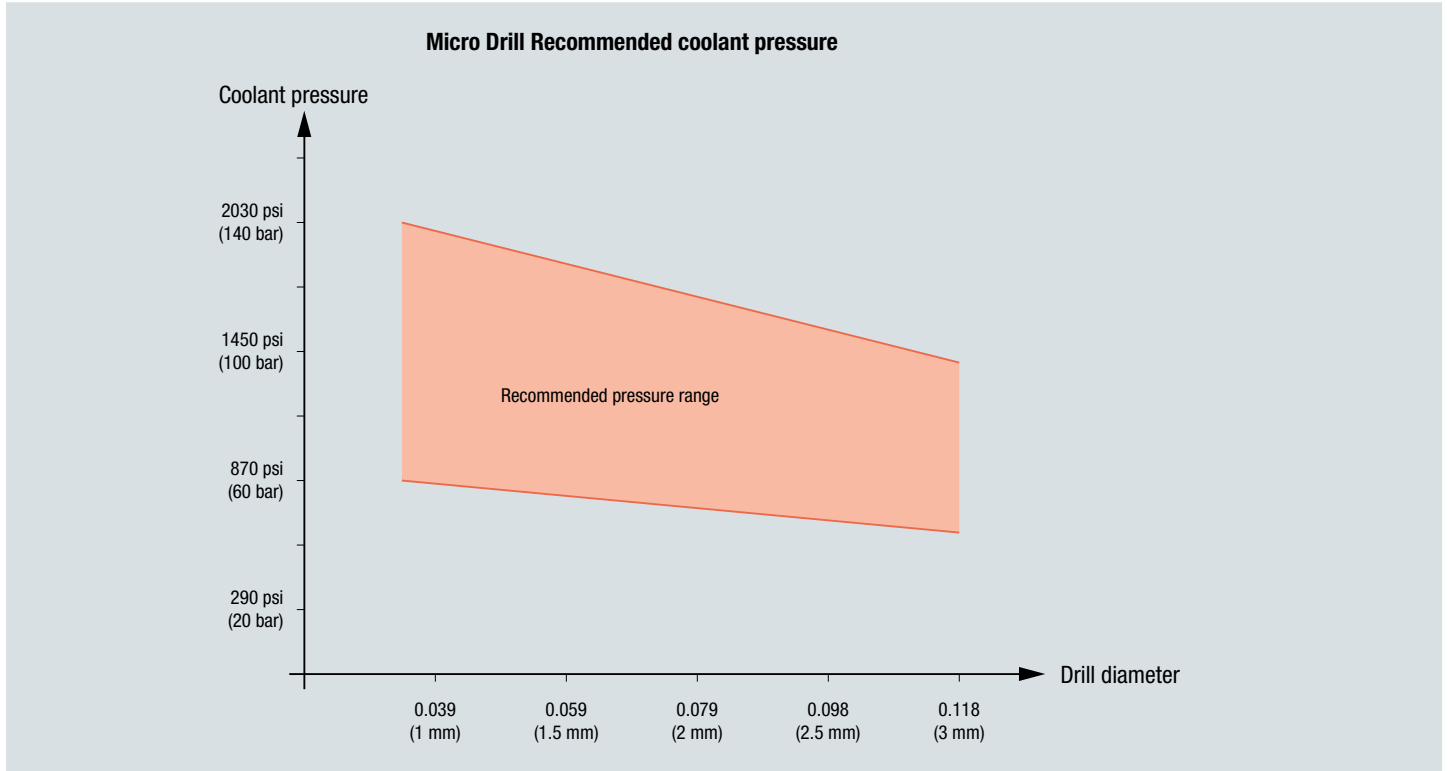

Problems, possible causes and solutions in drilling

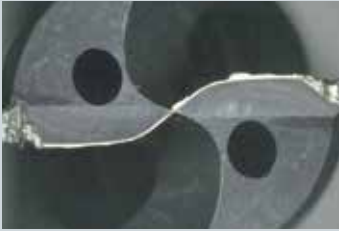

Problems:

- Excessive wear on the corners
- Built-up edge
- Wear on the margins

Possible causes:

- Excessive machining times
- High temperature and/or friction
- Concentricity run-out > 0.02 mm
- Unstable clamping of workpiece or tool
- Coolant-lubricant too dry

Solutions:

- Exchange twist drill in time and regrind
- Increase coolant-lubricant volume
- Use coolant-lubricant with higher oil content, or additives
- Reduce cutting speed
- Reduce feed for drilling through

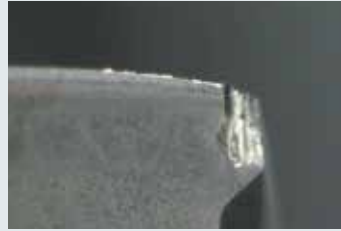

Problem:

- Chipping on the cutting corners

Possible causes:

- Excessive feed
- Workpiece moves when the drill breaks through
- Machine is unstable
- Twist drill slips due to unsatisfactory tool clamping
- Concentricity run-out > 0.02 mm

Solutions:

- Improve workpiece clamping
- Use a different clamping tool, e.g. clamping system FPC or hydraulic expansion chuck
- Reduce feed



Problem:

- Coating coming off on the margins

Possible causes:

- Excessive friction
- Slanted exit
- Adhesive workpiece material
- Reground too many times (excessive coating thickness)

Solutions:

- Use coolant-lubricant with higher oil content, or additives
- Reduce feed for exiting
- Reduce the number of times you regrind your drills



Problem:

- Built-up edge on the primary cutting edge

Possible causes:

- Wrong cutting data
- Excessive wear on relief surfaces
- Damage on the cutting edges
- Bad coolant-lubricant supply

Solutions:

- Use coolant-lubricant with higher oil content, or additives
- Increase cutting speed
- Reduce feed
- Exchange tools



Problem:

- Splintering on the chisel edge

Possible causes:

- Vibrations
- Concentricity run-out > 0.02 mm
- Rough or slanted workpiece surface

Solutions:

- Reduce feed
- Use a different clamping tool, e.g. clamping system FPC or hydraulic expansion chuck
- Improve workpiece surface (e.g. by spot-facing)



Extend the Life of Your Drills



RECONDITIONING SERVICE

EMUGE-FRANKEN guarantees the restoration of the original EMUGE tool geometry.



TRANSPORT TOOLS TO EMUGE CORP.

Tools can be sent either to EMUGE-FRANKEN directly, or picked up by your local EMUGE-FRANKEN sales contact. Our special TOOL BOX is available if needed.



REGRINDING AND RECOATING

Tools are carefully checked for their condition. If suitable, drills are resharpener on production machines and restored to the same level of quality and specifications of the original tool.



SHIPPING

Reground and recoated drills are returned after 2-3 weeks to the address specified by you, in new protective packaging.



COMPLETE METALWORKING SOLUTIONS

(800) 991-4225

www.ahbinc.com

ISO Certified

customerservice@ahbinc.com

EMUGE-FRANKEN has been the product technology and performance leader in their field for 100 years. EMUGE-FRANKEN manufactures an extensive line of taps, drills, thread mills, end mills, toolholders, clamping devices and other rotary cutting tools, over 40,000 items sold through distributors worldwide.

EMUGE-FRANKEN USA
1800 Century Drive, West Boylston, MA 01583

Literature EDP No.: **EFUZP00087**
Copyright © 2025 Emuge Corp. 3M-1/25 MA Printed in USA