

**Radiaac**  
Abrasives  
Engineered Grinding Solutions

**ST@RM**<sup>TM</sup>  
SERIES



**Superabrasive Wheels**  
*for the*  
**Round Tool Industry**

ISO Certified 9001 - 2000



# Grinding Round Tools on CNC Equipment Exclusively with Radiac STORM™



Radiac's new Storm™ Series of Diamond and CBN wheels was specifically developed for the cutting tool industry. Whether regrinding round tools or manufacturing from solids, Radiac has high performance wheels for all CNC equipment.

Featuring high metal removal rates, longer wheel life, better form holding and reduced cycle times, Radiac's Storm Series has proven to substantially reduce grinding costs in the field. A key characteristic of the Storm technology allows these products to draw lower machine power but afford a cooler and burr free cut at the same time. Whether it's the Typhoon™ wheel for smaller depths of cut on older machines or the Tempest™ for deeper cuts on newer machines, Radiac's Storm Series has the wheel for your round tool application. Call 800-851-1095 to get started on a guaranteed performance test today.

Storm Series Product	Application	Machine	Depth of Cut
<b>Typhoon™</b>	Regrinding Round Tools  Less than or equal to ½" Diameter	Older Generation CNC Machines Under 10 HP	.002 - .050
<b>Tempest™</b>	Regrinding and Manufacturing Round Tools from solids Over ½" Diameter and Larger	Newer CNC Machines 10 HP and Over	Up to .300

## Common CNC Machines

- Anca
- Deckel
- Guhring
- Huffman
- Junker
- Normac
- Reinecker
- Rollomatic
- Unison
- Walter

### Common Wheel Shapes for Grinding Round Tools

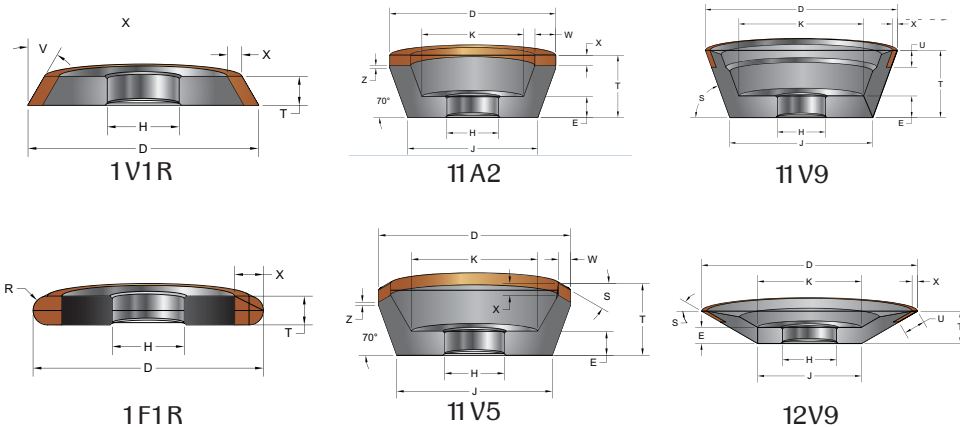



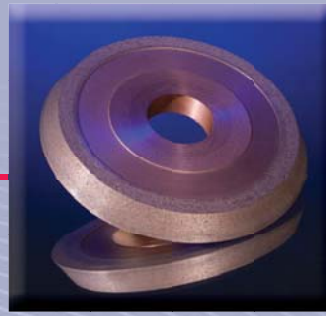

## Typhoon Success Stories

**Application:** Flute Grinding 3" Tapered Milling Cutter  
**Machine:** Anca TX7+  
**Material:** M2 Steel  
**Wheel:** 6 x 3/4 x 1-1/4 (1A1R) CBN220-R-BX702K-1/4  
**Competition:** 3-M: CB 220 PMX BPP 1/4  
**Advantage:** Customer grinding parts Radiac 40% faster, reducing cycle time from over 45 to 28 minutes per tool with Radiac's Typhoon wheel.

**Application:** Grinding 1" Two Fluted End Mill  
**Machine:** Anca TG7  
**Material:** Solid Carbide  
**Wheel:** 5 x 5/8 x 2 (1A1R) D280-R-BX702-1/4  
**Competition:** Univel: G-Force  
**Advantage:** Using Radiac's Typhoon technology, customer made part in 2/3 the normal time using 40% less power.

# Tempest™

## Tempest Success Stories

**Application:** Grinding primary and secondary angles on 1" 8 fluted end mill  
**Machine:** New Walter Power - 16 HP  
**Material:** 1" Diameter Carbide  
**Wheel:** 5 x 1-1/2 x 1-1/4 (11B2) D320-R-M100-1/4  
**Competition:** Regal: 2D240MF7HTB  
**Advantage:** Competitor's wheel required (4) .010" passes and wheel re-truing after 175 parts. Radiac's Tempest used only 2 passes, doubling the feed rate, yielding 459 parts before re-truing.

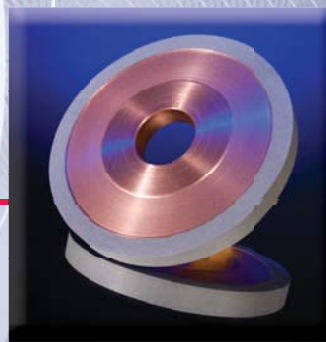

**Application:** Fluting from a solid, 4 flute 3/4" end mill  
**Machine:** Walter Vision 45 HP  
**Material:** Solid Carbide  
**Wheel:** 5 x 1/2 x 1-1/4 (1A1R) D280-R-M100-1/4  
**Competition:** Univel: G-Force  
**Advantage:** Radiac's Tempest improved depth of cut by 23% and cut 17% better with the same 25% amp meter reading, drawing no more load than the competition but removing stock much faster.





# Using Radiac's Storm™ Series Line

## FEATURES

- Hybrid bonding designed specifically for Diamond and CBN crystals
- Self-sharpening cutting surface
- Low wear formulation

## BENEFITS

- Long wheel life
- High metal removal rates
- Less dressing
- Excellent form holding
- Reduced cycle times
- Low power draw

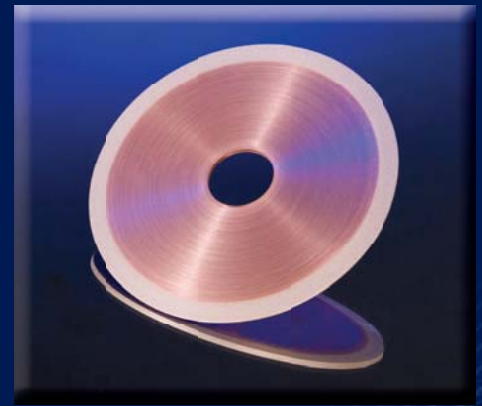

## The Radiac Commitment

- From the very beginning, Radiac Engineers will work hand-in-hand with Manufacturing Engineers, OEM's, Tool Designers and Ceramic Engineers to develop the most robust application possible.
- Radiac will provide Next-step On-site Engineer assisted testing.
- Radiac is committed to Continual Process Improvement and to bringing the latest Round Tool grinding developments in CBN & Diamond advancements to the customer.
- Radiac will match or exceed the performance of any competitor's wheel.
- Radiac CBN & Diamond products are 100% performance guaranteed - call 800-851-1095 or e-mail us at sales@radiac.com for a no-risk test today.

### Corporate Headquarters

Radiac Abrasives, Inc.  
A Tyrolit Company  
1015 South College Avenue  
P.O. Box 1410  
Salem, IL 62881

Tel: 800-851-1095 618-548-4200  
Fax: 888-244-8234 618-548-4207  
E-mail: sales@radiac.com

### West Coast Operations

Radiac Abrasives, Inc.  
13120 State Avenue  
Marysville, WA 98271

Tel: 800-538-0712  
Fax: 360-658-3032  
E-mail: sales@radiac.com

### Superabrasive Division

Radiac Abrasives, Inc.  
101 Kendall Point Drive  
Oswego, IL 60543

Tel: 800-223-0457  
Fax: 630-898-1796  
E-mail: sales@usdw.com

## Distributed by:

An Authorized Radiac Abrasives Distributor



[www.radiac.com](http://www.radiac.com)

