



ALLIED MACHINE & ENGINEERING CORP.

ALVAN[®] Reamers



Represented by:





ALLIED MACHINE & ENGINEERING CORP.

Our focus on product excellence, service to the customer, respect for the individual, and competitive advantage enables us to deliver outstanding results in a diverse range of manufacturing, production, and process engineering industries.

As a result, Allied high performance tooling is helping countless businesses across the world produce better products with greater accuracy, increased speed, and higher quality.

Precision, performance, and productivity are core features of Allied tooling, and our commitment to innovation in all aspects of hole making technology means we continually set new industry standards in production efficiency, tool life, and manufacturing cost improvements.

This product catalog provides detailed information on products in a comprehensive, easy-to-use, and informative single source reference guide. However, we recognize that every company's needs are unique, which is why our customer service and technical support teams are always available to provide help and advice should you need it.

Whatever you need, Allied Machine & Engineering Corp. delivers high performance tooling on the cutting edge.

 **WARNING**

Tool failure during use can cause serious injury. Follow safety precautions and instructions that accompany machinery and all tools.

Wear safety glasses and appropriate safety equipment at all times when machinery is operating.

ALVAN® Reamers

Table of Contents



Allied Machine & Engineering Corp. offers ALVAN® Reamers through an exclusive supply agreement with S.C.A.M.I. s.n.c.

Allied Machine & Engineering Corp. is pleased to offer ALVAN® Reamers through an exclusive supply agreement with S.C.A.M.I. s.n.c. S.C.A.M.I. is an Italian manufacturer that has been producing high quality cutting tools for over 40 years.

In addition to producing close tolerances and dimensional accuracy of machined holes, this high performance reaming product provides a lower cost per hole through its high penetration rates, making it an ideal choice for finishing holes in a production environment. It can also prove to be an alternative to finish boring by providing more consistent hole sizes and lower cycle times.

Visit our website at www.alliedmachine.com for additional information about all Allied products, or contact our Application Engineering Department for technical assistance.



Table of Contents

S.C.A.M.I. Reconditioning Service	Page 2
Replaceable Head Reamers	Page 3
Replaceable Head Speeds & Feeds	Page 14 - 15
Replaceable Head Set-Up Information	Page 16
Monobloc Reamers	Page 17 - 27
Monobloc Troubleshooting Guide	Page 28
Cutting Rings	Page 29 - 45
Cutting Rings Instructions	Page 46
Cutting Rings Speeds & Feeds	Page 47 - 50
ALVAN® Accessories	Page 51 - 57
ALVAN® Reamer Troubleshooting Guide	Page 58



Allied Machine & Engineering Corp.
120 Deeds Drive, Dover, Ohio 44622
Telephone: (330) 343-4283
Toll Free USA & Canada: (800) 321-5537
Fax: (330) 602-3400
Toll Free USA & Canada: (800) 223-5140
International Country Code: 01
Website Address: www.alliedmachine.com
Email Address: info@alliedmachine.com

S.C.A.M.I.

Reconditioning Service

All ALVAN® Reamers can be reconditioned to help reduce your overall tooling costs. This service is provided through Allied Machine & Engineering Corp. by utilizing the expertise of S.C.A.M.I.

Please ship any reamer safely packaged with a purchase order to the address shown below.

Item numbers for reconditioning will be as shown in the example below:

Monobloc (35 work days)

New item number: AL3620I04853
Reconditioned item number: AL3620I04853RP1

Ring (35 work days)

New item number: AL2TIAI05820
Reconditioned item number: AL2TIAI05820RP1

New Replaceable Head (25 work days)

New item number: I7405-SVG-10000
Reconditioned item number: R I7405SVG10000

We will process the tools with a 25 - 35 work day lead time, depending on style, from the date we receive the tools and purchase order.

Please ship all tools with purchase order to:

Allied Machine & Engineering Corp.
Attn: Regrind Department
120 Deeds Drive
Dover, OH 44622

Replaceable Head



- Fixed diameter heads allow for on-machine replacement, significantly reducing set-up and downtime
- Quick delivery on uncoated fixed diameter heads as low as 10 days
- Replaceable design allows for multiple diameters within the same arbor, reducing inventory requirements
- Several leads provide tailored solution for each application
- H7 tolerance capable on fixed diameter heads
- Tight tolerances (ffl 0.0002") capable with expandable diameter head design



ALVAN® Replaceable Head Reamers

Nomenclature

I		7700	-	K	N	G	-	18000
Unit of Measure	Head Style	Substrate	Coating	Lead	Diameter			
I - Inch	7700 - Fixed Helical Flute	K - Carbide	L - Uncoated Carbide	G T	Inch - X.XXXX			
Blank - Metric	7705 - Expandable Helical Flute	S - Cermet	V - Uncoated Cermet	A F	Metric - XX.XXX			
	7400 - Fixed Straight Flute		N - TiN	N M				
	7405 - Expandable Straight Flute		C - TiCN	L E				
			A - TiAlN	V X				
				J Y				
				W				

R		I	7700	K	N	G	-	18000
Reconditioned	Unit of Measure	Head Style	Substrate	Coating	Lead	Diameter		
R	I - Inch	7700 - Fixed Helical Flute	K - Carbide	L - Uncoated Carbide	G T	Inch - X.XXXX		
	Blank - Metric	7705 - Expandable Helical Flute	S - Cermet	V - Uncoated Cermet	A F	Metric - XX.XXX		
		7400 - Fixed Straight Flute		N - TiN	N M			
		7405 - Expandable Straight Flute		C - TiCN	L E			
			A - TiAlN	V X				
				J Y				
				W				

ALVAN® Replaceable Head Reamers

Lead Angle Descriptions



Left Hand Helical Flute Leads

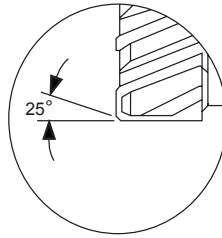
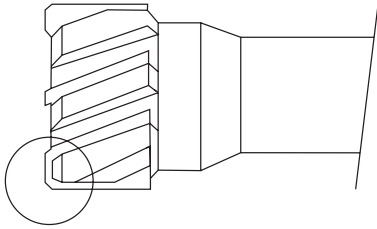

"E" lead-in (left hand helical flutes) is standard and suitable for most materials (only through hole)

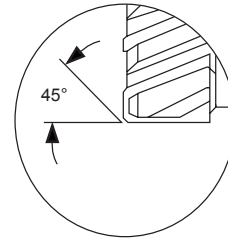

"M" lead-in (left hand helical flutes) may provide better penetration rates in steels over 200 BHN (only through hole)

Straight Flute Leads

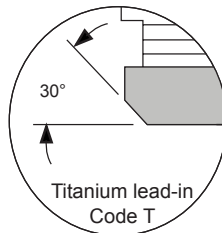
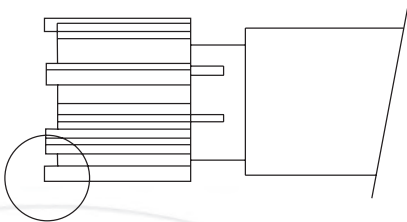

"T" lead-in is suitable for titanium based alloys

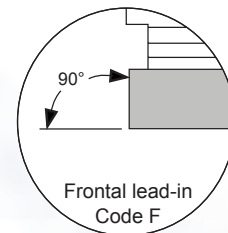

"F" lead-in can be used for stock removal at the bottom of the hole. Reduce the feed by 40% of the values on pages 47-50 ("Y" lead with chipbreaker)

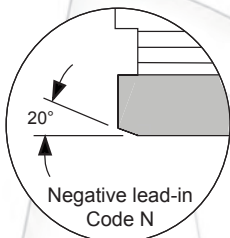

"N" lead-in is ideal for through holes. It is possible to increase the feed up to 100% of the values on pages 47-50

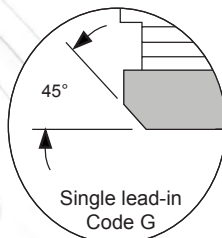

"G" lead-in is standard and suitable for most materials ("X" lead with chipbreaker)

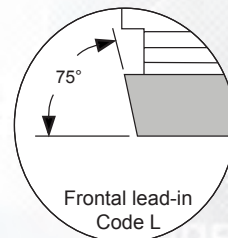

"L" lead-in may provide improved straightness. Reduce the feed by 40% of the values on pages 47-50 ("W" lead with chipbreaker)

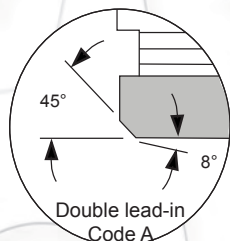

"A" lead-in can be used to improve finish

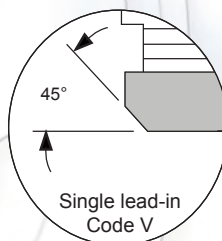

"V" lead-in is suitable for most materials and increases tool life ("J" lead with chipbreaker)



ALVAN® Replaceable Head Reamers

0.4656" - 2.3858" (11,80 - 60,60 mm)

Fixed Heads (7700/7400) H7 tolerance		
Diameter in(mm)	Tolerance in(mm)	
	Minimum	Maximum
0.4656" - 0.7086" (11,800 - 18,000)	+0" (+0)	+0.0007" (+0,018)
0.7087" - 1.1811" (18,001 - 30,000)	+0" (+0)	+0.0008" (+0,021)
1.1812" - 1.5748" (30,001 - 40,000)	+0" (+0)	+0.0010" (+0,025)
1.5749" - 1.9685" (40,001 - 50,000)	+0" (+0)	+0.0012" (+0,030)
1.9686" - 2.3858" (50,001 - 60,600)	+0" (+0)	+0.0014" (+0,035)

Expandable Heads (7705/7405)		
Diameter in(mm)	Tolerance in(mm)	
	Minimum	Maximum
0.4656" - 0.7086" (11,800 - 18,000)	-0.0002" (-0,005)	+0.0002" (+0,005)
0.7087" - 1.1811" (18,001 - 30,000)	-0.0002" (-0,005)	+0.0002" (+0,005)
1.1812" - 1.5748" (30,001 - 40,000)	-0.0002" (-0,005)	+0.0002" (+0,005)
1.5749" - 1.9685" (40,001 - 50,000)	-0.0002" (-0,005)	+0.0002" (+0,005)
1.9686" - 2.3858" (50,001 - 60,600)	-0.0002" (-0,005)	+0.0002" (+0,005)

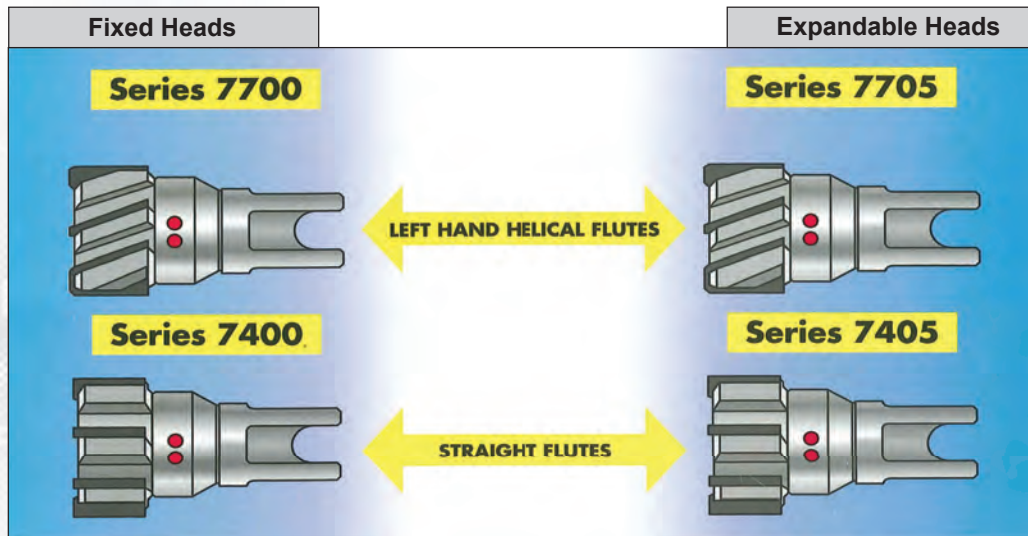

Code	Description
xxxx - KLx - Ø	Carbide cutting edges K05/K10
xxxx - KNx - Ø	Carbide cutting edges K05/K10 TIN-coated
xxxx - KCx - Ø	Carbide cutting edges K05/K10 TICN-coated
xxxx - KAx - Ø	Carbide cutting edges K05/K10 TIALN-coated
xxxx - SVx - Ø	Cermet cutting edges P10/P15
xxxx - SNx - Ø	Cermet cutting edges P10/P15 TIN-coated
xxxx - SCx - Ø	Cermet cutting edges P10/P15 TICN-coated
xxxx - SAx - Ø	Cermet cutting edges P10/P15 TIALN-coated

ALVAN® Replaceable Head Reamers

Recommended Lead Angles



Material	Material Hardness BHN	Lead Angle*
Iron and Mild Steel (C<0.2%)	125	G-A-E
Mild Steel (C 0.2 - 0.3%)	150	N-A-E
Mild Steel (C 0.3 - 0.4%)	200	N-A-E
Mild Steel (C 0.4 - 0.5%)	225	N-A-E
Alloy Steel	≤ 225	G-N-A-E
Alloy Steel	270	G-N-E
Alloy Steel	300	G-N-M
Alloy Steel	> 300	G-N-M
Stainless and Refractory Steel	from 125 to 270	G-N-M
Grey, Spheroidal and Malleable Cast Iron	from 150 to 320	G-N-E
Titanium and Titanium Alloy		T-E
Tempered Steel	48 - 64 Rc	G-N-M
Pure Copper		G-N-E
Electrolytic Copper		G-N-E
Brass / Bronze		G-N-E
Aluminum Alloy < 10% Si		G-A-E
Aluminum Alloy > 10% Si		G-E
Magnesium Alloy		G-A-E
Thermoplastic Material		G-E
Thermosetting Resins		G-E
Stiffened Synthetic Material		G-E

* Negative lead-in "N" can be used on a large range of materials. Please contact our Application Engineering Department. See page 5 for lead angle details.

Do not use negative lead-in on blind holes.



ALVAN® Replaceable Head Reamers

Short Length

Cylindrical Shank

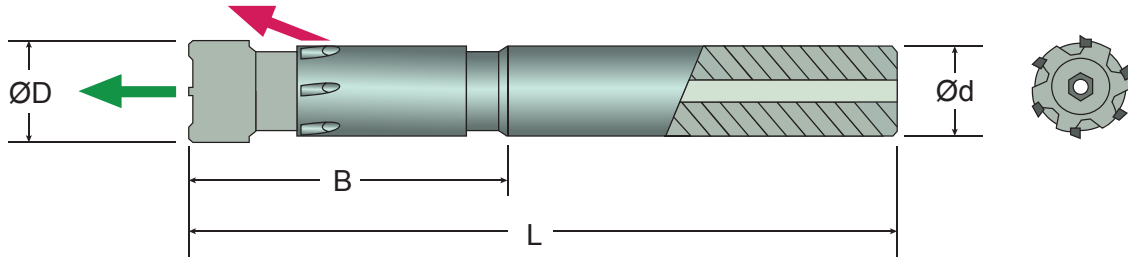

MANDREL CODE WITHOUT HEAD & SCREW	Ø D		B MM	L MM	Ød ^{h6} MM	LOCKING SCREW FIXED HEADS		LOCKING SCREW EXPANDING HEADS	
	IN	MM				*THROUGH HOLES	**BLIND HOLES	*THROUGH HOLES	**BLIND HOLES
7000-MC-001	0.4646 - 0.4964	11,800 - 12,609	50	95	12	7000-VI-001	7001-VI-001	7000-VI-012	7001-VI-012
	0.4965 - 0.5357	12,610 - 13,609						7000-VI-013	7001-VI-013
	0.5358 - 0.5751	13,610 - 14,609						7000-VI-014	7001-VI-014
7000-MC-002	0.5752 - 0.6145	14,610 - 15,609	65	113	16	7000-VI-002	7001-VI-002	7000-VI-015	7001-VI-015
	0.6146 - 0.6538	15,610 - 16,609						7000-VI-016	7001-VI-016
	0.6539 - 0.6932	16,610 - 17,609						7000-VI-017	7001-VI-017
7000-MC-003	0.6933 - 0.7326	17,610 - 18,609	75	125	20	7000-VI-003	7001-VI-003	7000-VI-018	7001-VI-018
	0.7327 - 0.7719	18,610 - 19,609						7000-VI-019	7001-VI-019
	0.7720 - 0.8113	19,610 - 20,609						7000-VI-020	7001-VI-020
	0.8114 - 0.8507	20,610 - 21,609						7000-VI-021	7001-VI-021
7000-MC-004	0.8508 - 0.8901	21,610 - 22,609	85	135	20	7000-VI-004	7001-VI-004	7000-VI-022	7001-VI-022
	0.8902 - 0.9294	22,610 - 23,609						7000-VI-023	7001-VI-023
	0.9295 - 0.9688	23,610 - 24,609						7000-VI-024	7001-VI-024
	0.9689 - 1.0082	24,610 - 25,609						7000-VI-025	7001-VI-025
	1.0083 - 1.0475	25,610 - 26,609						7000-VI-026	7001-VI-026
7000-MC-005	1.0476 - 1.0869	26,610 - 27,609	105	161	25	7000-VI-005	7001-VI-005	7000-VI-027	7001-VI-027
	1.0870 - 1.1263	27,610 - 28,609						7000-VI-028	7001-VI-028
	1.1264 - 1.1656	28,610 - 29,609						7000-VI-029	7001-VI-029
	1.1657 - 1.2050	29,610 - 30,609						7000-VI-030	7001-VI-030
	1.2051 - 1.2444	30,610 - 31,609						7000-VI-031	7001-VI-031
	1.2445 - 1.2838	31,610 - 32,609						7000-VI-032	7001-VI-032
7000-MC-006	1.2839 - 1.3231	32,610 - 33,609	120	180	32	7000-VI-006	7001-VI-006	7000-VI-033	7001-VI-033
	1.3232 - 1.3625	33,610 - 34,609						7000-VI-034	7001-VI-034
	1.3626 - 1.4019	34,610 - 35,609						7000-VI-035	7001-VI-035
	1.4020 - 1.4412	35,610 - 36,609						7000-VI-036	7001-VI-036
	1.4413 - 1.4806	36,610 - 37,609						7000-VI-037	7001-VI-037
	1.4807 - 1.5200	37,610 - 38,609						7000-VI-038	7001-VI-038
	1.5201 - 1.5593	38,610 - 39,609						7000-VI-039	7001-VI-039
1.5594 - 1.5987	39,610 - 40,609	7000-VI-040	7001-VI-040						
7000-MC-007	1.5988 - 1.6381	40,610 - 41,609	120	180	32	7000-VI-007	7001-VI-007	7000-VI-041	7001-VI-041
	1.6382 - 1.6775	41,610 - 42,609						7000-VI-042	7001-VI-042
	1.6776 - 1.7168	42,610 - 43,609						7000-VI-043	7001-VI-043
	1.7169 - 1.7562	43,610 - 44,609						7000-VI-044	7001-VI-044
	1.7563 - 1.7956	44,610 - 45,609						7000-VI-045	7001-VI-045

All mandrels are provided with radial through tool coolant.

* Through hole reaming - order locking screw to suit through holes.

** Blind hole reaming - order locking screw to suit blind holes. The screw allows central through tool coolant.

Stocked

Non-Stocked

ALVAN® Replaceable Head Reamers

Short Length

Cylindrical Shank

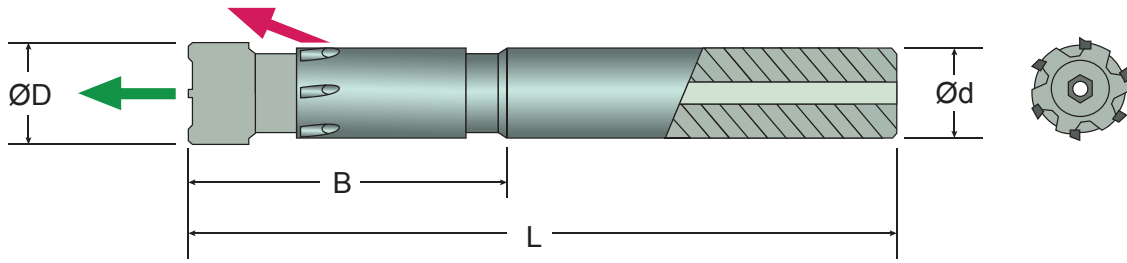

MANDREL CODE WITHOUT HEAD & SCREW	Ø D		B MM	L MM	Ød ^{h6} MM	LOCKING SCREW FIXED HEADS		LOCKING SCREW EXPANDING HEADS	
	IN	MM				*THROUGH HOLES	**BLIND HOLES	*THROUGH HOLES	**BLIND HOLES
7000-MC-007	1.7957 - 1.8349	45,610 - 46,609	120	180	32	7000-VI-007	7001-VI-007	7000-VI-046	7001-VI-046
	1.8350 - 1.8743	46,610 - 47,609						7000-VI-047	7001-VI-047
	1.8744 - 1.9137	47,610 - 48,609						7000-VI-048	7001-VI-048
	1.9138 - 1.9530	48,610 - 49,609						7000-VI-049	7001-VI-049
	1.9531 - 1.9924	49,610 - 50,609						7000-VI-050	7001-VI-050
7000-MC-008	1.9925 - 2.0318	50,610 - 51,609	120	190	40	7000-VI-008	7001-VI-008	7000-VI-051	7001-VI-051
	2.0319 - 2.0712	51,610 - 52,609						7000-VI-052	7001-VI-052
	2.0713 - 2.1105	52,610 - 53,609						7000-VI-053	7001-VI-053
	2.1106 - 2.1499	53,610 - 54,609						7000-VI-054	7001-VI-054
	2.1500 - 2.1893	54,610 - 55,609						7000-VI-055	7001-VI-055
	2.1894 - 2.2286	55,610 - 56,609						7000-VI-056	7001-VI-056
	2.2287 - 2.2680	56,610 - 57,609						7000-VI-057	7001-VI-057
	2.2681 - 2.3074	57,610 - 58,609						7000-VI-058	7001-VI-058
	2.3075 - 2.3468	58,610 - 59,609						7000-VI-059	7001-VI-059
	2.3469 - 2.3858	59,610 - 60,600						7000-VI-060	7001-VI-060

All mandrels are provided with radial through tool coolant.

* Through hole reaming - order locking screw to suit through holes.

** Blind hole reaming - order locking screw to suit blind holes. The screw allows central through tool coolant.

- Stocked
- Non-Stocked

ALVAN® Replaceable Head Reamers



ALVAN® Replaceable Head Reamers

Long Length

Cylindrical Shank

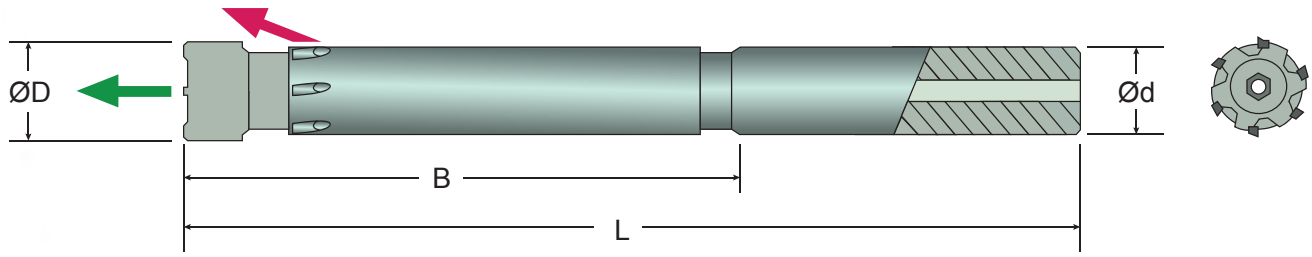

MANDREL CODE WITHOUT HEAD & SCREW	Ø D		B MM	L MM	Ød ^{h6} MM	LOCKING SCREW FIXED HEADS		LOCKING SCREW EXPANDING HEADS	
	IN	MM				*THROUGH HOLES	**BLIND HOLES	*THROUGH HOLES	**BLIND HOLES
7000-ML-001	0.4646 - 0.4964	11,800 - 12,609	95	140	12	7000-VI-001	7001-VI-001	7000-VI-012	7001-VI-012
	0.4965 - 0.5357	12,610 - 13,609						7000-VI-013	7001-VI-013
	0.5358 - 0.5751	13,610 - 14,609						7000-VI-014	7001-VI-014
7000-ML-002	0.5752 - 0.6145	14,610 - 15,609	105	153	16	7000-VI-002	7001-VI-002	7000-VI-015	7001-VI-015
	0.6146 - 0.6538	15,610 - 16,609						7000-VI-016	7001-VI-016
	0.6539 - 0.6932	16,610 - 17,609						7000-VI-017	7001-VI-017
7000-ML-003	0.6933 - 0.7326	17,610 - 18,609	125	175	20	7000-VI-003	7001-VI-003	7000-VI-018	7001-VI-018
	0.7327 - 0.7719	18,610 - 19,609						7000-VI-019	7001-VI-019
	0.7720 - 0.8113	19,610 - 20,609						7000-VI-020	7001-VI-020
	0.8114 - 0.8507	20,610 - 21,609						7000-VI-021	7001-VI-021
7000-ML-004	0.8508 - 0.8901	21,610 - 22,609	145	195	20	7000-VI-004	7001-VI-004	7000-VI-022	7001-VI-022
	0.8902 - 0.9294	22,610 - 23,609						7000-VI-023	7001-VI-023
	0.9295 - 0.9688	23,610 - 24,609						7000-VI-024	7001-VI-024
	0.9689 - 1.0082	24,610 - 25,609						7000-VI-025	7001-VI-025
	1.0083 - 1.0475	25,610 - 26,609						7000-VI-026	7001-VI-026
7000-ML-005	1.0476 - 1.0869	26,610 - 27,609	165	221	25	7000-VI-005	7001-VI-005	7000-VI-027	7001-VI-027
	1.0870 - 1.1263	27,610 - 28,609						7000-VI-028	7001-VI-028
	1.1264 - 1.1656	28,610 - 29,609						7000-VI-029	7001-VI-029
	1.1657 - 1.2050	29,610 - 30,609						7000-VI-030	7001-VI-030
	1.2051 - 1.2444	30,610 - 31,609						7000-VI-031	7001-VI-031
	1.2445 - 1.2838	31,610 - 32,609						7000-VI-032	7001-VI-032
7000-ML-006	1.2839 - 1.3231	32,610 - 33,609	185	245	32	7000-VI-006	7001-VI-006	7000-VI-033	7001-VI-033
	1.3232 - 1.3625	33,610 - 34,609						7000-VI-034	7001-VI-034
	1.3626 - 1.4019	34,610 - 35,609						7000-VI-035	7001-VI-035
	1.4020 - 1.4412	35,610 - 36,609						7000-VI-036	7001-VI-036
	1.4413 - 1.4806	36,610 - 37,609						7000-VI-037	7001-VI-037
	1.4807 - 1.5200	37,610 - 38,609						7000-VI-038	7001-VI-038
	1.5201 - 1.5593	38,610 - 39,609						7000-VI-039	7001-VI-039
1.5594 - 1.5987	39,610 - 40,609	7000-VI-040	7001-VI-040						
7000-ML-007	1.5988 - 1.6381	40,610 - 41,609	185	245	32	7000-VI-007	7001-VI-007	7000-VI-041	7001-VI-041
	1.6382 - 1.6775	41,610 - 42,609						7000-VI-042	7001-VI-042
	1.6776 - 1.7168	42,610 - 43,609						7000-VI-043	7001-VI-043
	1.7169 - 1.7562	43,610 - 44,609						7000-VI-044	7001-VI-044
	1.7563 - 1.7956	44,610 - 45,609						7000-VI-045	7001-VI-045

All mandrels are provided with radial through tool coolant.

* Through hole reaming - order locking screw to suit through holes.

** Blind hole reaming - order locking screw to suit blind holes. The screw allows central through tool coolant.



Stocked



Non-Stocked

ALVAN® Replaceable Head Reamers

Long Length

Cylindrical Shank

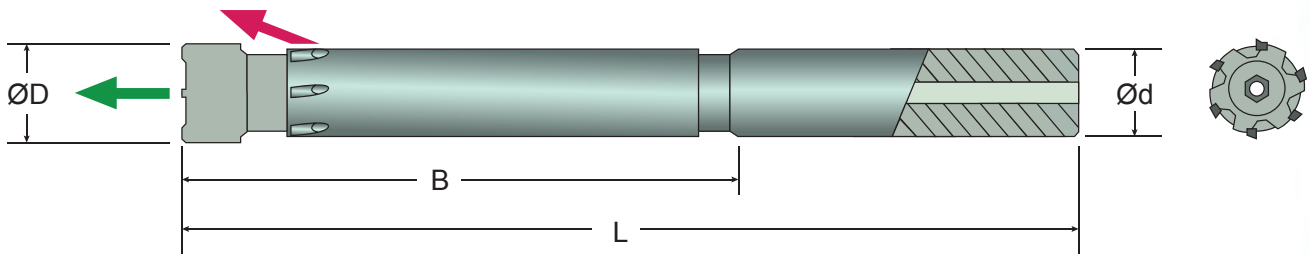

MANDREL CODE WITHOUT HEAD & SCREW	Ø D		B MM	L MM	Ød ^{h6} MM	LOCKING SCREW FIXED HEADS		LOCKING SCREW EXPANDING HEADS	
	IN	MM				*THROUGH HOLES	**BLIND HOLES	*THROUGH HOLES	**BLIND HOLES
7000-ML-007	1.7957 - 1.8349	45,610 - 46,609	185	245	32	7000-VI-007	7001-VI-007	7000-VI-046	7001-VI-046
	1.8350 - 1.8743	46,610 - 47,609						7000-VI-047	7001-VI-047
	1.8744 - 1.9137	47,610 - 48,609						7000-VI-048	7001-VI-048
	1.9138 - 1.9530	48,610 - 49,609						7000-VI-049	7001-VI-049
	1.9531 - 1.9924	49,610 - 50,609						7000-VI-050	7001-VI-050
7000-ML-008	1.9925 - 2.0318	50,610 - 51,609	185	255	40	7000-VI-008	7001-VI-008	7000-VI-051	7001-VI-051
	2.0319 - 2.0712	51,610 - 52,609						7000-VI-052	7001-VI-052
	2.0713 - 2.1105	52,610 - 53,609						7000-VI-053	7001-VI-053
	2.1106 - 2.1499	53,610 - 54,609						7000-VI-054	7001-VI-054
	2.1500 - 2.1893	54,610 - 55,609						7000-VI-055	7001-VI-055
	2.1894 - 2.2286	55,610 - 56,609						7000-VI-056	7001-VI-056
	2.2287 - 2.2680	56,610 - 57,609						7000-VI-057	7001-VI-057
	2.2681 - 2.3074	57,610 - 58,609						7000-VI-058	7001-VI-058
	2.3075 - 2.3468	58,610 - 59,609						7000-VI-059	7001-VI-059
	2.3469 - 2.3858	59,610 - 60,600						7000-VI-060	7001-VI-060

All mandrels are provided with radial through tool coolant.

* Through hole reaming - order locking screw to suit through holes.

** Blind hole reaming - order locking screw to suit blind holes. The screw allows central through tool coolant.

- Stocked
- Non-Stocked

ALVAN® Replaceable Head Reamers



ALVAN® Replaceable Head Reamers

Standard Length

Modular Shank

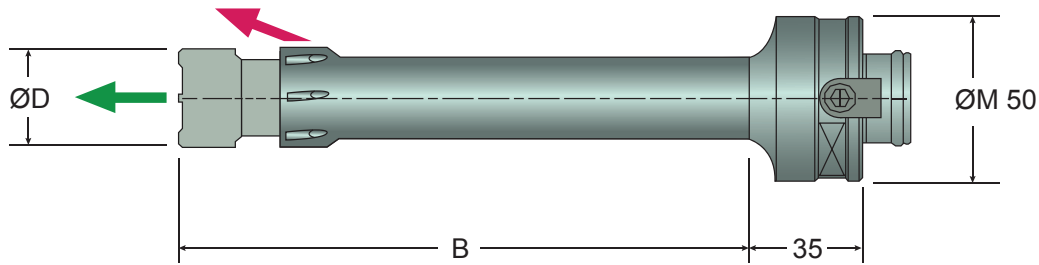

MANDREL CODE WITHOUT HEAD & SCREW	Ø D		B MM	LOCKING SCREW FIXED HEADS		LOCKING SCREW EXPANDING HEADS	
	IN	MM		*THROUGH HOLES	**BLIND HOLES	*THROUGH HOLES	**BLIND HOLES
7000-MM-001	0.4646 - 0.4964	11,800 - 12,609	65	7000-VI-001	7001-VI-001	7000-VI-012	7001-VI-012
	0.4965 - 0.5357	12,610 - 13,609				7000-VI-013	7001-VI-013
	0.5358 - 0.5751	13,610 - 14,609				7000-VI-014	7001-VI-014
7000-MM-002	0.5752 - 0.6145	14,610 - 15,609	80	7000-VI-002	7001-VI-002	7000-VI-015	7001-VI-015
	0.6146 - 0.6538	15,610 - 16,609				7000-VI-016	7001-VI-016
	0.6539 - 0.6932	16,610 - 17,609				7000-VI-017	7001-VI-017
7000-MM-003	0.6933 - 0.7326	17,610 - 18,609	90	7000-VI-003	7001-VI-003	7000-VI-018	7001-VI-018
	0.7327 - 0.7719	18,610 - 19,609				7000-VI-019	7001-VI-019
	0.7720 - 0.8113	19,610 - 20,609				7000-VI-020	7001-VI-020
	0.8114 - 0.8507	20,610 - 21,609				7000-VI-021	7001-VI-021
7000-MM-004	0.8508 - 0.8901	21,610 - 22,609	100	7000-VI-004	7001-VI-004	7000-VI-022	7001-VI-022
	0.8902 - 0.9294	22,610 - 23,609				7000-VI-023	7001-VI-023
	0.9295 - 0.9688	23,610 - 24,609				7000-VI-024	7001-VI-024
	0.9689 - 1.0082	24,610 - 25,609				7000-VI-025	7001-VI-025
	1.0083 - 1.0475	25,610 - 26,609				7000-VI-026	7001-VI-026
7000-MM-005	1.0476 - 1.0869	26,610 - 27,609	110	7000-VI-005	7001-VI-005	7000-VI-027	7001-VI-027
	1.0870 - 1.1263	27,610 - 28,609				7000-VI-028	7001-VI-028
	1.1264 - 1.1656	28,610 - 29,609				7000-VI-029	7001-VI-029
	1.1657 - 1.2050	29,610 - 30,609				7000-VI-030	7001-VI-030
	1.2051 - 1.2444	30,610 - 31,609				7000-VI-031	7001-VI-031
	1.2445 - 1.2838	31,610 - 32,609				7000-VI-032	7001-VI-032
7000-MM-006	1.2839 - 1.3231	32,610 - 33,609	120	7000-VI-006	7001-VI-006	7000-VI-033	7001-VI-033
	1.3232 - 1.3625	33,610 - 34,609				7000-VI-034	7001-VI-034
	1.3626 - 1.4019	34,610 - 35,609				7000-VI-035	7001-VI-035
	1.4020 - 1.4412	35,610 - 36,609				7000-VI-036	7001-VI-036
	1.4413 - 1.4806	36,610 - 37,609				7000-VI-037	7001-VI-037
	1.4807 - 1.5200	37,610 - 38,609				7000-VI-038	7001-VI-038
	1.5201 - 1.5593	38,610 - 39,609				7000-VI-039	7001-VI-039
1.5594 - 1.5987	39,610 - 40,609	7000-VI-040	7001-VI-040				
7000-MM-007	1.5988 - 1.6381	40,610 - 41,609	120	7000-VI-007	7001-VI-007	7000-VI-041	7001-VI-041
	1.6382 - 1.6775	41,610 - 42,609				7000-VI-042	7001-VI-042
	1.6776 - 1.7168	42,610 - 43,609				7000-VI-043	7001-VI-043
	1.7169 - 1.7562	43,610 - 44,609				7000-VI-044	7001-VI-044
	1.7563 - 1.7956	44,610 - 45,609				7000-VI-045	7001-VI-045

All mandrels are provided with radial through tool coolant.

* Through hole reaming - order locking screw to suit through holes.

** Blind hole reaming - order locking screw to suit blind holes. The screw allows central through tool coolant.

- Stocked
- Non-Stocked

ALVAN® Replaceable Head Reamers Standard Length Modular Shank

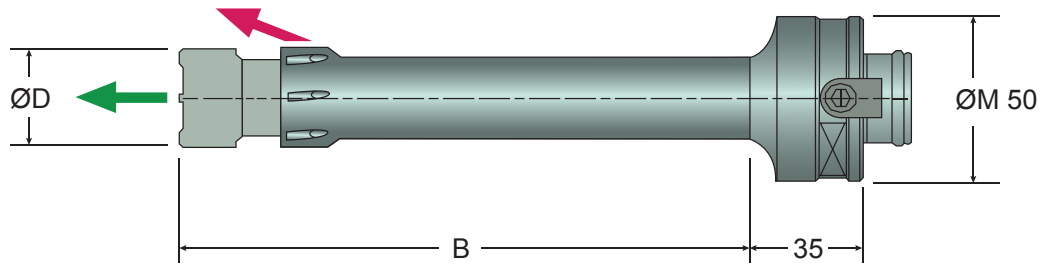

MANDREL CODE WITHOUT HEAD & SCREW	Ø D		B MM	LOCKING SCREW FIXED HEADS		LOCKING SCREW EXPANDING HEADS	
	IN	MM		*THROUGH HOLES	**BLIND HOLES	*THROUGH HOLES	**BLIND HOLES
	7000-MM-007	1.7957 - 1.8349 1.8350 - 1.8743 1.8744 - 1.9137 1.9138 - 1.9530 1.9531 - 1.9924		45,610 - 46,609 46,610 - 47,609 47,610 - 48,609 48,610 - 49,609 49,610 - 50,609	120	7000-VI-007	7001-VI-007
7000-MM-008	1.9925 - 2.0318 2.0319 - 2.0712 2.0713 - 2.1105 2.1106 - 2.1499 2.1500 - 2.1893 2.1894 - 2.2286 2.2287 - 2.2680 2.2681 - 2.3074 2.3075 - 2.3468 2.3469 - 2.3858	50,610 - 51,609 51,610 - 52,609 52,610 - 53,609 53,610 - 54,609 54,610 - 55,609 55,610 - 56,609 56,610 - 57,609 57,610 - 58,609 58,610 - 59,609 59,610 - 60,600	120	7000-VI-008	7001-VI-008	7000-VI-051 7000-VI-052 7000-VI-053 7000-VI-054 7000-VI-055 7000-VI-056 7000-VI-057 7000-VI-058 7000-VI-059 7000-VI-060	7001-VI-051 7001-VI-052 7001-VI-053 7001-VI-054 7001-VI-055 7001-VI-056 7001-VI-057 7001-VI-058 7001-VI-059 7001-VI-060

All mandrels are provided with radial through tool coolant.

* Through hole reaming - order locking screw to suit through holes.

** Blind hole reaming - order locking screw to suit blind holes. The screw allows central through tool coolant.

- Stocked
- Non-Stocked

ALVAN® Replaceable Head Reamers



ALVAN® Replaceable Head Reamers

Recommended Speeds & Feeds
Inch

Material	Material Hardness (BHN)	Reamer Ø (in)	Stock Allowance (in)	Carbide Speed (sfm)	Coated Carbide Speed (sfm)	Cermet Speed (sfm)	Lead-in (A,G,L*,F*) Feed (ipr)	Lead-in (E,N,M) Feed (ipr)
Mild Steel Free Machining Steel	Up to 180	0.4646 - 0.8504	0.006 - 0.010	35 - 65	200 - 260	300 - 980	0.010 - 0.024	0.020 - 0.024
		0.8505 - 1.5590	0.008 - 0.016				0.012 - 0.032	0.024 - 0.048
Low Alloyed Structural Steel	Greater than 180	0.4646 - 0.8504	0.006 - 0.010	25 - 50	130 - 230	260 - 600	0.012 - 0.024	0.016 - 0.032
		0.8505 - 1.5590	0.008 - 0.016				0.016 - 0.032	0.020 - 0.040
		1.5591 - 2.3858	0.012 - 0.016				0.020 - 0.035	0.024 - 0.048
Alloy Steel Stainless Steel	120 - 300	0.4646 - 0.8504	0.006 - 0.010	20 - 35	100 - 160	200 - 490	0.012 - 0.024	0.016 - 0.032
		0.8505 - 1.5590	0.008 - 0.016				0.016 - 0.032	0.020 - 0.040
		1.5591 - 2.3858	0.012 - 0.016				0.020 - 0.035	0.024 - 0.048
High Strength Alloy Steel with Manganese	240 - 450	0.4646 - 0.8504	0.006 - 0.010	13 - 36	50 - 100	200 - 390	0.010 - 0.020	0.012 - 0.024
		0.8505 - 1.5590	0.008 - 0.016				0.012 - 0.024	0.016 - 0.032
		1.5591 - 2.3858	0.012 - 0.016				0.016 - 0.028	0.020 - 0.040
Stainless Steel	120 - 300	0.4646 - 0.8504	0.006 - 0.010	20 - 35	100 - 160	200 - 490	0.012 - 0.024	0.016 - 0.032
		0.8505 - 1.5590	0.008 - 0.016				0.016 - 0.032	0.020 - 0.040
		1.5591 - 2.3858	0.012 - 0.016				0.020 - 0.035	0.024 - 0.048
Grey Cast Iron Spheroidal Cast Iron (pearlitic) Malleable Cast Iron	Up to 200	0.4646 - 0.8504	0.006 - 0.010	65 - 130	160 - 230	-	0.008 - 0.024	0.020 - 0.040
	Greater than 180	0.8505 - 1.5590	0.008 - 0.016	50 - 100			0.012 - 0.028	0.024 - 0.048
		1.5591 - 2.3858	0.012 - 0.016				0.024 - 0.050	0.032 - 0.063
Spheroidal Cast Iron (ferritic)	Up to 200	0.4646 - 0.8504	0.006 - 0.010	35 - 50	100 - 160	200 - 400	0.008 - 0.024	0.020 - 0.024
		0.8505 - 1.5590	0.008 - 0.016				0.012 - 0.028	0.024 - 0.048
		1.5591 - 2.3858	0.012 - 0.016				0.016 - 0.032	0.032 - 0.063
Copper and Alloys Brass	Up to 500	0.4646 - 0.8504	0.006 - 0.010	200 - 660	330 - 660	-	0.008 - 0.024	-
		0.8505 - 1.5590	0.008 - 0.016				0.012 - 0.028	
		1.5591 - 2.3858	0.012 - 0.016				0.016 - 0.032	
Bronze Bronze Phosphorous	Up to 180	0.4646 - 0.8504	0.006 - 0.010	65 - 130	260 - 520	330 - 980	0.012 - 0.024	0.016 - 0.040
		0.8505 - 1.5590	0.008 - 0.016				0.024 - 0.048	
		1.5591 - 2.3858	0.012 - 0.016				0.024 - 0.060	
Aluminum and Alloys	Up to 150	0.4646 - 0.8504	0.006 - 0.010	65 - 660	-	-	0.012 - 0.024	-
		0.8505 - 1.5590	0.008 - 0.016				0.016 - 0.040	
		1.5591 - 2.3858	0.012 - 0.016				0.016 - 0.040	
Titanium and Alloys**	-	0.4646 - 0.8504	0.006 - 0.010	20 - 50	60 - 200	-	0.008 - 0.016	-
		0.8505 - 1.5590	0.008 - 0.016				0.012 - 0.020	
		1.5591 - 2.3858	0.012 - 0.016				0.016 - 0.024	

* Reduce feed rates by 40% when using "L" and "F" lead-in

** Use "T" lead for Titanium based Alloys

ALVAN® Replaceable Head Reamers

Recommended Speeds & Feeds

Metric



Material	Material Hardness (BHN)	Reamer Ø (mm)	Stock Allowance (mm)	Carbide Speed (m/min)	Coated Carbide Speed (m/min)	Cermet Speed (m/min)	Lead-in (A,G,L*,F*) Feed (mm/rev)	Lead-in (E,N,M) Feed (mm/rev)
Mild Steel Free Machining Steel	Up to 180	11,80 - 21,60	0,15 - 0,25	10 - 20	60 - 80	90 - 300	0,25 - 0,60	0,50 - 0,60
		21,61 - 39,60	0,20 - 0,40				0,30 - 0,80	0,60 - 1,20
Low Alloyed Structural Steel	Greater than 180	11,80 - 21,60	0,15 - 0,25	7 - 15	40 - 70	80 - 200	0,30 - 0,60	0,40 - 0,80
		21,61 - 39,60	0,20 - 0,40				0,40 - 0,80	0,50 - 1,00
39,61 - 60,60	0,30 - 0,40	0,50 - 0,90	0,60 - 1,20					
Alloy Steel	120 - 300	11,80 - 21,60	0,15 - 0,25	6 - 10	30 - 50	60 - 150	0,30 - 0,60	0,40 - 0,80
		21,61 - 39,60	0,20 - 0,40				0,40 - 0,80	0,50 - 1,00
39,61 - 60,60	0,30 - 0,40	0,50 - 0,90	0,60 - 1,20					
High Strength Alloy Steel with Manganese	240 - 450	11,80 - 21,60	0,15 - 0,25	4 - 8	15 - 30	60 - 120	0,25 - 0,50	0,30 - 0,60
		21,61 - 39,60	0,20 - 0,40				0,30 - 0,60	0,40 - 0,80
39,61 - 60,60	0,30 - 0,40	0,40 - 0,70	0,50 - 1,00					
Stainless Steel	120 - 300	11,80 - 21,60	0,15 - 0,25	6 - 10	30 - 50	60 - 150	0,30 - 0,60	0,40 - 0,80
		21,61 - 39,60	0,20 - 0,40				0,40 - 0,80	0,50 - 1,00
39,61 - 60,60	0,30 - 0,40	0,50 - 0,90	0,60 - 1,20					
Grey Cast Iron Spheroidal Cast Iron (pearlitic) Malleable Cast Iron	Up to 200	11,80 - 21,60	0,15 - 0,25	20 - 40	50 - 70	-	0,20 - 0,60	0,50 - 1,00
		21,61 - 39,60	0,20 - 0,40	15 - 30			0,30 - 0,70	0,60 - 1,20
39,61 - 60,60	0,30 - 0,40	0,60 - 1,30	0,80 - 1,60					
Spheroidal Cast Iron (ferritic)	Up to 200	11,80 - 21,60	0,15 - 0,25	10 - 15	30 - 50	60 - 120	0,20 - 0,60	0,50 - 0,60
		21,61 - 39,60	0,20 - 0,40				0,30 - 0,70	0,60 - 1,20
39,61 - 60,60	0,30 - 0,40	0,40 - 0,80	0,80 - 1,60					
Copper and Alloys Brass	Up to 500	11,80 - 21,60	0,15 - 0,25	60 - 200	100 - 200	-	0,20 - 0,60	-
		21,61 - 39,60	0,20 - 0,40				0,30 - 0,70	
39,61 - 60,60	0,30 - 0,40	0,40 - 0,80						
Bronze Bronze Phosphorous	Up to 180	11,80 - 21,60	0,15 - 0,25	20 - 40	80 - 160	100 - 300	0,30 - 0,60	0,40 - 1,00
		21,61 - 39,60	0,20 - 0,40				0,50 - 1,20	
39,61 - 60,60	0,30 - 0,40	0,60 - 1,50						
Aluminum and Alloys	Up to 150	11,80 - 21,60	0,15 - 0,25	20 - 200	-	-	0,30 - 0,60	-
		21,61 - 39,60	0,20 - 0,40				0,40 - 1,00	
39,61 - 60,60	0,30 - 0,40	0,40 - 1,00						
Titanium and Alloys**	-	11,80 - 21,60	0,15 - 0,25	6 - 15	20 - 60	-	0,20 - 0,40	-
		21,61 - 39,60	0,20 - 0,40				0,30 - 0,50	
39,61 - 60,60	0,30 - 0,40	0,40 - 0,60						

* Reduce feed rates by 40% when using "L" and "F" lead-in

** Use "T" lead for Titanium based Alloys

ALVAN® Replaceable Head Reamers



ALVAN[®] Replaceable Head Reamers

Set-up Information

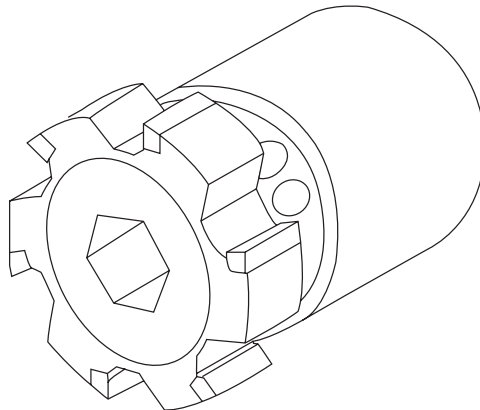

1) Diameter Measurement

The diameter of the heads is measured with a micrometer. To avoid chipping of the cutting edges, we would recommend the use of a comparator with at least 2 μ m resolution. The cutting edges are an asymmetric design with only two cutting edges exactly 180° opposed to allow setting. These are marked with a colored dimple (see diagram above). Measurement must be taken from the front of the cutting edges only.

2) Expanding Heads Adjustment

When the size reaches its lower tolerance, the head can be adjusted to compensate for wear to the cutting edges. This operation can be repeated several times until the surface finish of the hole deteriorates to an unacceptable level.

Recommended Tightening Torque for Fixed Head Reamer (7400 / 7700)	
Diameter in(mm)	Torque in-lbs(N-m)
0.465" - 0.575" (11,80 - 14,60)	22.1 (2.5)
0.575" - 0.693" (14,61 - 17,60)	26.6 (3.0)
0.693" - 0.850" (17,61 - 21,60)	31.0 (3.5)
0.851" - 1.047" (21,61 - 26,60)	35.4 (4.0)
1.048" - 1.283" (26,61 - 32,60)	62.0 (7.0)
1.284" - 1.598" (32,61 - 40,60)	88.5 (10.0)
1.599" - 1.992" (40,61 - 50,60)	123.9 (14.0)
1.993" - 2.386" (50,61 - 60,60)	159.3 (18.0)

Monobloc Reamers



- Diameter range from 0.2283" - 1.2638"
(5,80 mm - 32,10 mm)
- Expandable design allows for up to 1% adjustment of diameter
- Capable of holding extremely tight hole tolerance (0.0002" (0,005 mm))
- Available coated and uncoated with Carbide, Cermet, PCD and CBN cutting edges
- Several leads provide tailored solution for each application



ALVAN® Monobloc Item Descriptions

Expandable Reamers are available with the following cutting edges:

- Carbide – Standard speed reaming
- Coated Carbide – High speed reaming
- Cermet – High speed reaming

CODE	DESCRIPTION
xxxxx - ALx - Ø	Uncoated K10 Carbide Cutting Edges
xxxxx - TNx - Ø	TiN Coated K10 Carbide Cutting Edges
xxxxx - TCx - Ø	TiCN Coated K10 Carbide Cutting Edges
xxxxx - TAx - Ø	TiAlN Coated K10 Carbide Cutting Edges
xxxxx - KLx - Ø	Uncoated K01 Carbide Cutting Edges
xxxxx - KNx - Ø	TiN Coated K01 Carbide Cutting Edges
xxxxx - KCx - Ø	TiCN Coated K01 Carbide Cutting Edges
xxxxx - KAx - Ø	TiAlN Coated K01 Carbide Cutting Edges
xxxxx - AVx - Ø	Uncoated P05 Cermet Cutting Edges
xxxxx - VNx - Ø	TiN Coated P05 Cermet Cutting Edges
xxxxx - VCx - Ø	TiCN Coated P05 Cermet Cutting Edges
xxxxx - VAx - Ø	TiAlN Coated P05 Cermet Cutting Edges
xxxxx - SVx - Ø	Uncoated P01 Cermet Cutting Edges
xxxxx - SNx - Ø	TiN Coated P01 Cermet Cutting Edges
xxxxx - SCx - Ø	TiCN Coated P01 Cermet Cutting Edges
xxxxx - SAx - Ø	TiAlN Coated P01 Cermet Cutting Edges

- **K01 Carbide is more wear resistant than K10 Carbide and may provide improved tool life in abrasive materials**
- **P01 Cermet is more wear resistant than P05 Cermet and may provide improved tool life in abrasive materials**

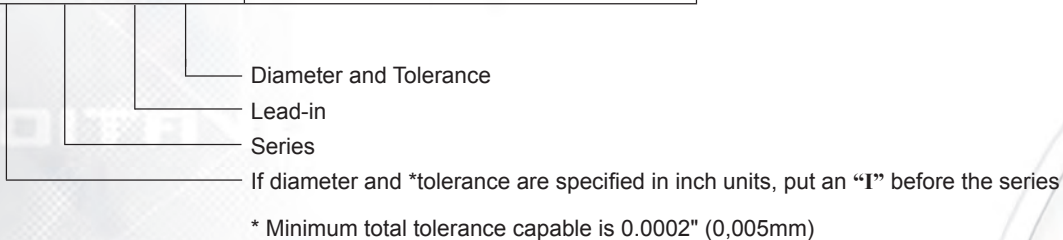

Ordering Examples:

For reaming a .6250" (+.0000", -.0005") diameter hole using an expanding reamer series 2441 with TiN coated K01 carbide cutting edges and negative lead in, use the following code:

I2441-KNN-006250+0000-0005

For reaming an 8mm (+0.006mm, -0.000mm) diameter hole using an expanding reamer series 93620 with uncoated P01 cermet cutting edges and 45° lead, use the following code:

93620-SVG-008000+006-000

ALVAN® Monobloc Reamers

Lead Angle Descriptions



Left Hand Helical Flute Leads

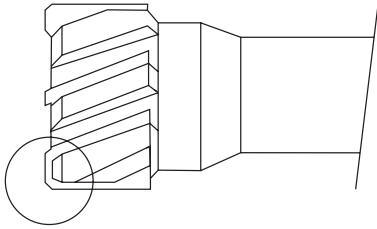

Left hand helical flute cutting rings from diameter 1.2835" to 7.8972"

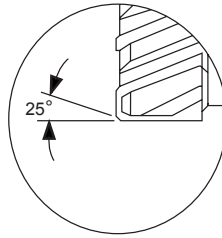

"E" lead-in (left hand helical flutes) is standard and suitable for most materials (only through hole)

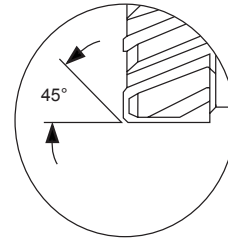

"M" lead-in (left hand helical flutes) may provide better penetration rates in steels over 200 BHN (only through hole)

Straight Flute Leads

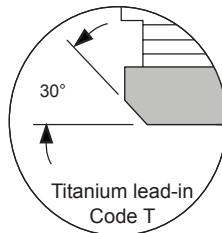
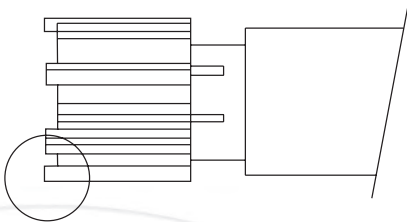

Titanium lead-in Code T
"T" lead-in is suitable for titanium based alloys

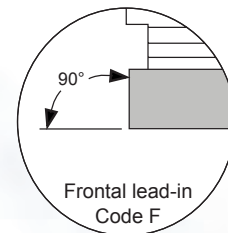

Frontal lead-in Code F
"F" lead-in can be used for stock removal at the bottom of the hole. Reduce the feed by 40% of the values on pages 47-50 ("Y" lead with chipbreaker)

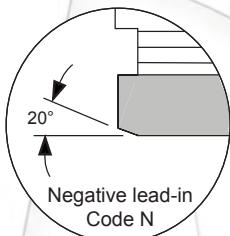

Negative lead-in Code N
"N" lead-in is ideal for through holes. It is possible to increase the feed up to 100% of the values on pages 47-50

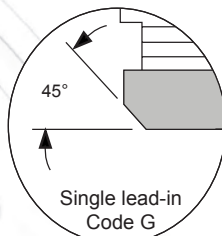

Single lead-in Code G
"G" lead-in is standard and suitable for most materials ("X" lead with chipbreaker)

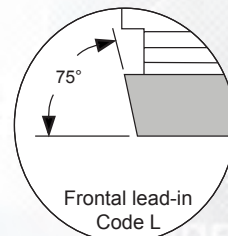

Frontal lead-in Code L
"L" lead-in may provide improved straightness. Reduce the feed by 40% of the values on pages 47-50 ("W" lead with chipbreaker)

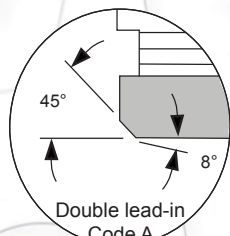

Double lead-in Code A
"A" lead-in can be used to improve finish

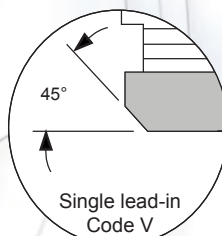

Single lead-in Code V
"V" lead-in is suitable for most materials and increases tool life ("J" lead with chipbreaker)



ALVAN® Monobloc Reamers

Short Length

Straight Flute

NO COOLANT Inch Shank - Series 92440 Metric Shank - Series 2440

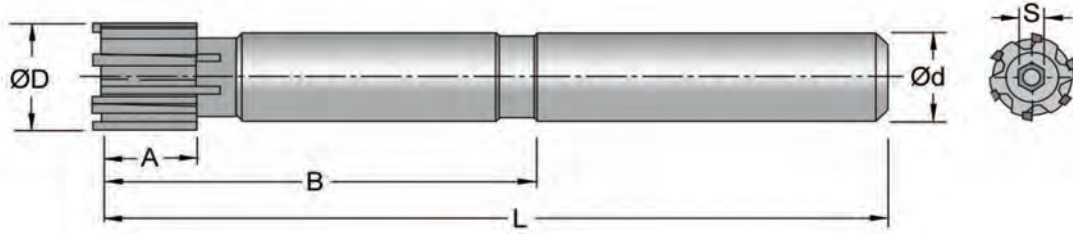

CENTRAL COOLANT - BLIND HOLES Inch Shank - Series 92441 Metric Shank - Series 2441

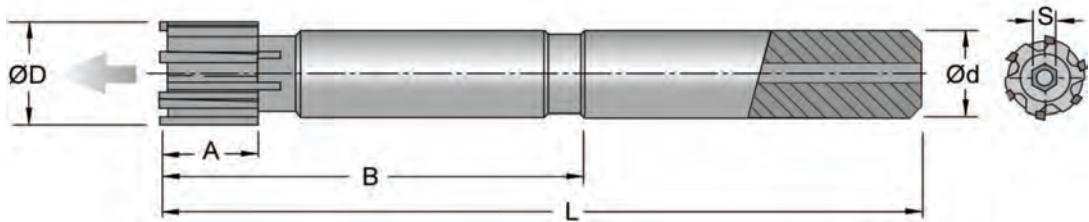

ØD (inch)	A (inch)	B (inch)	L (inch)	Series 92440 and 92441	Series 2440 and 2441	Number of Teeth	Hex Key
				Ød ^{h7} (inch)	Ød ^{h7} (mm)		S (mm)
0.2283 - 0.2598	0.315	1.575	3.150	0.500	12	4	2
0.2599 - 0.2992	0.315	1.575	3.150	0.500	12	4	2
0.2993 - 0.3386	0.394	1.575	3.150	0.500	12	4	2,5
0.3387 - 0.3780	0.394	1.969	3.543	0.500	12	4	2,5
0.3781 - 0.4173	0.394	1.969	3.740	0.500	12	6	3
0.4174 - 0.4567	0.394	2.362	4.134	0.500	12	6	3
0.4568 - 0.4961	0.394	2.362	4.134	0.500	12	6	3
0.4962 - 0.5354	0.394	2.362	4.134	0.500	12	6	4
0.5355 - 0.5748	0.394	2.362	4.528	0.500	12	6	4
0.5749 - 0.6142	0.394	2.362	4.528	0.500	12	6	4
0.6143 - 0.6535	0.394	3.150	5.118	0.625	16	6	4
0.6536 - 0.6929	0.394	3.150	5.118	0.625	16	6	5
0.6930 - 0.7323	0.472	3.543	5.512	0.625	16	6	5
0.7324 - 0.7520	0.472	3.543	5.906	0.750	20	6	5
0.7521 - 0.7913	0.472	3.937	6.229	0.750	20	6	5
0.7914 - 0.8307	0.472	3.937	6.229	0.750	20	6	5
0.8308 - 0.8701	0.472	3.937	6.229	0.750	20	6	6
0.8702 - 0.9094	0.472	3.937	6.229	0.750	20	6	6
0.9095 - 0.9488	0.472	3.937	6.229	0.750	20	6	6
0.9489 - 0.9882	0.472	3.937	6.229	0.750	20	6	6
0.9883 - 1.0276	0.472	4.331	6.693	1.000	25	6	6
1.0277 - 1.0669	0.551	4.331	6.693	1.000	25	6	6
1.0670 - 1.1063	0.551	4.331	6.693	1.000	25	6	8
1.1064 - 1.1457	0.551	4.331	6.693	1.000	25	6	8
1.1458 - 1.1850	0.551	4.331	6.693	1.000	25	6	8
1.1851 - 1.2244	0.551	4.331	6.693	1.000	25	6	8
1.2245 - 1.2638	0.551	4.331	6.693	1.000	25	6	8

ALVAN® Monobloc Reamers

Short Length

Straight Flute



RADIAL COOLANT - THROUGH HOLES

Inch Shank - Series 93620

Metric Shank - Series 3620

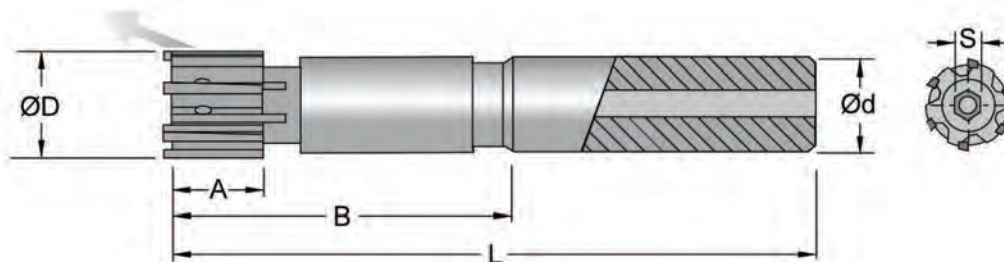

ØD (inch)	A (inch)	B (inch)	L (inch)	Series 93620	Series 3620	Number of Teeth	Hex Key S (mm)
				Ød ^{h7} (inch)	Ød ^{h7} (mm)		
0.2283 - 0.2598	0.315	1.575	3.071	0.500	12	4	2
0.2599 - 0.2992	0.315	1.575	3.071	0.500	12	4	2
0.2993 - 0.3386	0.394	1.575	3.071	0.500	12	4	2,5
0.3387 - 0.3780	0.394	1.969	3.465	0.500	12	4	2,5
0.3781 - 0.4173	0.394	1.969	3.740	0.500	12	6	3
0.4174 - 0.4567	0.394	1.969	3.740	0.500	12	6	3
0.4568 - 0.4961	0.394	1.969	3.740	0.500	12	6	3
0.4962 - 0.5354	0.394	1.969	3.740	0.500	12	6	4
0.5355 - 0.5748	0.394	1.969	3.740	0.500	12	6	4
0.5749 - 0.6142	0.394	1.969	3.740	0.500	12	6	4
0.6143 - 0.6535	0.394	1.969	3.937	0.625	16	6	4
0.6536 - 0.6929	0.394	1.969	3.937	0.625	16	6	5
0.6930 - 0.7323	0.472	1.969	3.937	0.625	16	6	5
0.7324 - 0.7520	0.472	2.362	4.724	0.750	20	6	5
0.7521 - 0.7913	0.472	2.362	4.724	0.750	20	6	5
0.7914 - 0.8307	0.472	2.362	4.724	0.750	20	6	5
0.8308 - 0.8701	0.472	2.362	4.724	0.750	20	6	6
0.8702 - 0.9094	0.472	2.362	4.724	0.750	20	6	6
0.9095 - 0.9488	0.472	2.362	4.724	0.750	20	6	6
0.9489 - 0.9882	0.472	2.362	4.724	0.750	20	6	6
0.9883 - 1.0276	0.472	2.953	5.315	1.000	25	6	6
1.0277 - 1.0669	0.551	2.953	5.315	1.000	25	6	6
1.0670 - 1.1063	0.551	2.953	5.315	1.000	25	6	8
1.1064 - 1.1457	0.551	2.953	5.315	1.000	25	6	8
1.1458 - 1.1850	0.551	2.953	5.315	1.000	25	6	8
1.1851 - 1.2244	0.551	2.953	5.315	1.000	25	6	8
1.2245 - 1.2638	0.551	2.953	5.315	1.000	25	6	8

ALVAN® Monobloc Reamers



ALVAN® Monobloc Reamers

Long Length

Straight Flute

NO COOLANT Inch Shank - Series 92430 Metric Shank - Series 2430

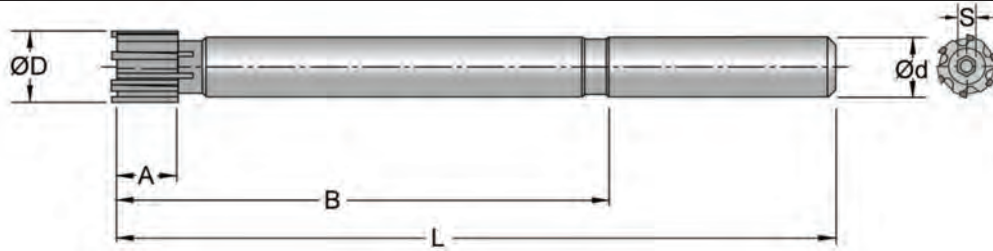

CENTRAL COOLANT - BLIND HOLES Inch Shank - Series 92431 Metric Shank - Series 2431



ØD (inch)	A (inch)	B (inch)	L (inch)	Series 92430 and 92431	Series 2430 and 2431	Number of Teeth	Hex Key S (mm)
				Ød ^{h7} (inch)	Ød ^{h7} (mm)		
0.2283 - 0.2598	0.315	3.346	4.843	0.500	12	4	2
0.2599 - 0.2992	0.315	3.346	4.843	0.500	12	4	2
0.2993 - 0.3386	0.394	3.346	4.843	0.500	12	4	2,5
0.3387 - 0.3780	0.394	3.346	4.843	0.500	12	4	2,5
0.3781 - 0.4173	0.394	4.528	6.299	0.500	12	6	3
0.4174 - 0.4567	0.394	4.528	6.299	0.500	12	6	3
0.4568 - 0.4961	0.394	4.528	6.299	0.500	12	6	3
0.4962 - 0.5354	0.394	4.528	6.299	0.500	12	6	4
0.5355 - 0.5748	0.394	4.528	6.299	0.500	12	6	4
0.5749 - 0.6142	0.394	4.528	6.299	0.500	12	6	4
0.6143 - 0.6535	0.394	5.118	7.087	0.625	16	6	4
0.6536 - 0.6929	0.394	5.118	7.087	0.625	16	6	5
0.6930 - 0.7323	0.472	5.118	7.087	0.625	16	6	5
0.7324 - 0.7520	0.472	5.512	7.874	0.750	20	6	5
0.7521 - 0.7913	0.472	5.512	7.874	0.750	20	6	5
0.7914 - 0.8307	0.472	5.512	7.874	0.750	20	6	5
0.8308 - 0.8701	0.472	5.512	7.874	0.750	20	6	6
0.8702 - 0.9094	0.472	5.512	7.874	0.750	20	6	6
0.9095 - 0.9488	0.472	5.512	7.874	0.750	20	6	6
0.9489 - 0.9882	0.472	5.512	7.874	0.750	20	6	6
0.9883 - 1.0276	0.472	5.906	8.268	1.000	25	6	6
1.0277 - 1.0669	0.551	5.906	8.268	1.000	25	6	6
1.0670 - 1.1063	0.551	5.906	8.268	1.000	25	6	8
1.1064 - 1.1457	0.551	5.906	8.268	1.000	25	6	8
1.1458 - 1.1850	0.551	5.906	8.268	1.000	25	6	8
1.1851 - 1.2244	0.551	5.906	8.268	1.000	25	6	8
1.2245 - 1.2638	0.551	5.906	8.268	1.000	25	6	8

ALVAN® Monobloc Reamers

Long Length

Straight Flute



RADIAL COOLANT - THROUGH HOLES

Inch Shank - Series 93610

Metric Shank - Series 3610

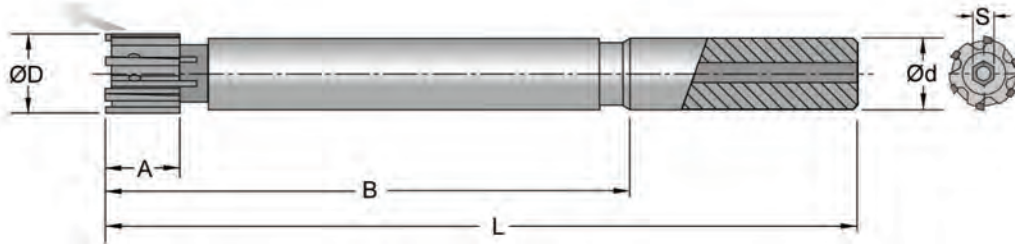

ØD (inch)	A (inch)	B (inch)	L (inch)	Series 93610	Series 3610	Number of Teeth	Hex Key S (mm)
				Ød ^{h7} (inch)	Ød ^{h7} (mm)		S (mm)
0.2283 - 0.2598	0.315	3.346	4.843	0.500	12	4	2
0.2599 - 0.2992	0.315	3.346	4.843	0.500	12	4	2
0.2993 - 0.3386	0.394	3.346	4.843	0.500	12	4	2,5
0.3387 - 0.3780	0.394	3.346	4.843	0.500	12	4	2,5
0.3781 - 0.4173	0.394	4.528	6.299	0.500	12	6	3
0.4174 - 0.4567	0.394	4.528	6.299	0.500	12	6	3
0.4568 - 0.4961	0.394	4.528	6.299	0.500	12	6	3
0.4962 - 0.5354	0.394	4.528	6.299	0.500	12	6	4
0.5355 - 0.5748	0.394	4.528	6.299	0.500	12	6	4
0.5749 - 0.6142	0.394	4.528	6.299	0.500	12	6	4
0.6143 - 0.6535	0.394	5.118	7.087	0.625	16	6	4
0.6536 - 0.6929	0.394	5.118	7.087	0.625	16	6	5
0.6930 - 0.7323	0.472	5.118	7.087	0.625	16	6	5
0.7324 - 0.7520	0.472	5.512	7.874	0.750	20	6	5
0.7521 - 0.7913	0.472	5.512	7.874	0.750	20	6	5
0.7914 - 0.8307	0.472	5.512	7.874	0.750	20	6	5
0.8308 - 0.8701	0.472	5.512	7.874	0.750	20	6	6
0.8702 - 0.9094	0.472	5.512	7.874	0.750	20	6	6
0.9095 - 0.9488	0.472	5.512	7.874	0.750	20	6	6
0.9489 - 0.9882	0.472	5.512	7.874	0.750	20	6	6
0.9883 - 1.0276	0.472	5.906	8.268	1.000	25	6	6
1.0277 - 1.0669	0.551	5.906	8.268	1.000	25	6	6
1.0670 - 1.1063	0.551	5.906	8.268	1.000	25	6	8
1.1064 - 1.1457	0.551	5.906	8.268	1.000	25	6	8
1.1458 - 1.1850	0.551	5.906	8.268	1.000	25	6	8
1.1851 - 1.2244	0.551	5.906	8.268	1.000	25	6	8
1.2245 - 1.2638	0.551	5.906	8.268	1.000	25	6	8

ALVAN® Monobloc Reamers



ALVAN® Monobloc Reamers

Tempered Guide

Straight Flute

NO COOLANT	Inch Shank - Series 92490	Metric Shank - Series 2490
------------	---------------------------	----------------------------

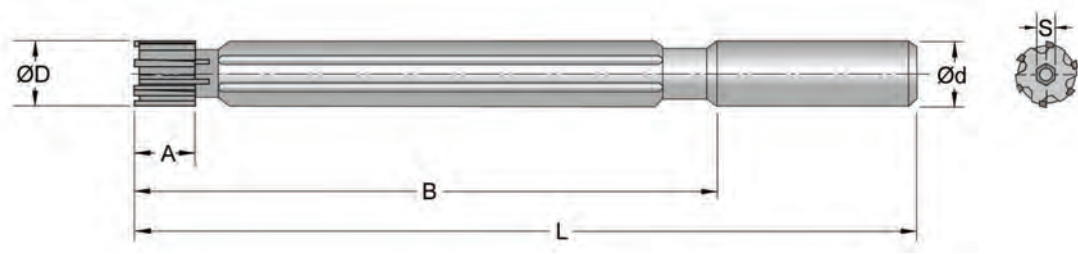

CENTRAL COOLANT - BLIND HOLES	Inch Shank - Series 92491	Metric Shank - Series 2491
-------------------------------	---------------------------	----------------------------

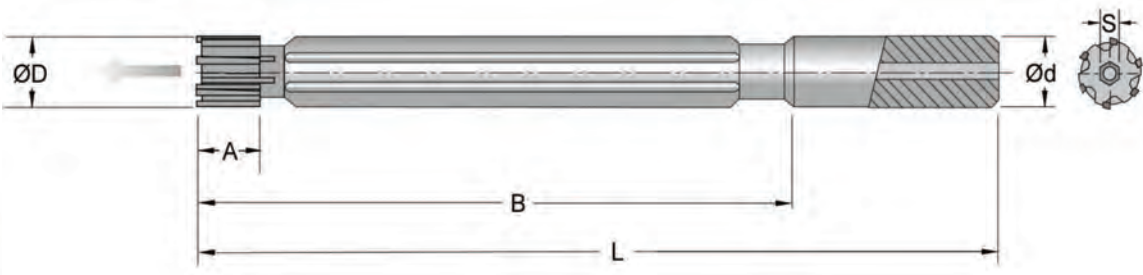

ØD (inch)	A (inch)	B (inch)	L (inch)	Series 92490 and 92491	Series 2490 and 2491	Number of Teeth	Hex Key S (mm)
				Ød ^{h7} (inch)	Ød ^{h7} (mm)		
0.2283 - 0.2598	0.315	2.913	3.937	0.500	12	4	2
0.2599 - 0.2992	0.315	2.913	3.937	0.500	12	4	2
0.2993 - 0.3386	0.394	3.622	4.724	0.500	12	4	2,5
0.3387 - 0.3780	0.394	3.622	4.724	0.500	12	4	2,5
0.3781 - 0.4173	0.394	4.252	5.512	0.500	12	6	3
0.4174 - 0.4567	0.394	4.252	5.512	0.500	12	6	3
0.4568 - 0.4961	0.394	4.331	5.906	0.500	12	6	3
0.4962 - 0.5354	0.394	4.528	6.299	0.500	12	6	4
0.5355 - 0.5748	0.394	4.921	6.693	0.500	12	6	4
0.5749 - 0.6142	0.394	5.118	6.890	0.500	12	6	4
0.6143 - 0.6535	0.394	5.118	7.087	0.625	16	6	4
0.6536 - 0.6929	0.394	5.512	7.480	0.625	16	6	5
0.6930 - 0.7323	0.472	5.709	7.677	0.625	16	6	5
0.7324 - 0.7520	0.472	5.906	8.071	0.750	20	6	5
0.7521 - 0.7913	0.472	5.906	8.071	0.750	20	6	5
0.7914 - 0.8307	0.472	6.102	8.268	0.750	20	6	5

The diameter of the guide area is 0.0004" - 0.0006" below the reamer diameter.
 Tempered guide tools are capable of speeds up to 130 SFM.
 Tool recommended with carbide substrate only AND only a through hole application.

ALVAN® Monobloc Reamers

Tempered Guide

Straight Flute



RADIAL COOLANT - THROUGH HOLES

Inch Shank - Series 93690

Metric Shank - Series 3690

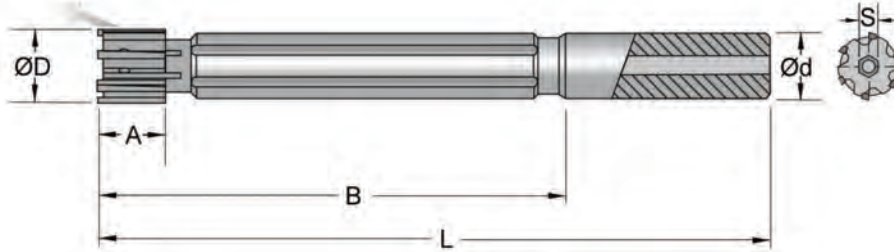

ØD (inch)	A (inch)	B (inch)	L (inch)	Series 93690	Series 3690	Number of Teeth	Hex Key S (mm)
				Ød ^{h7} (inch)	Ød ^{h7} (mm)		S (mm)
0.2283 - 0.2598	0.315	3.346	4.843	0.500	12	4	2
0.2599 - 0.2992	0.315	3.346	4.843	0.500	12	4	2
0.2993 - 0.3386	0.394	3.346	4.843	0.500	12	4	2,5
0.3387 - 0.3780	0.394	3.346	4.843	0.500	12	4	2,5
0.3781 - 0.4173	0.394	4.528	6.299	0.500	12	6	3
0.4174 - 0.4567	0.394	4.528	6.299	0.500	12	6	3
0.4568 - 0.4961	0.394	4.528	6.299	0.500	12	6	3
0.4962 - 0.5354	0.394	4.528	6.299	0.500	12	6	4
0.5355 - 0.5748	0.394	4.528	6.299	0.500	12	6	4
0.5749 - 0.6142	0.394	4.528	6.299	0.500	12	6	4
0.6143 - 0.6535	0.394	5.118	7.087	0.625	16	6	4
0.6536 - 0.6929	0.394	5.118	7.087	0.625	16	6	5
0.6930 - 0.7323	0.472	5.118	7.087	0.625	16	6	5
0.7324 - 0.7520	0.472	5.512	7.874	0.750	20	6	5
0.7521 - 0.7913	0.472	5.512	7.874	0.750	20	6	5
0.7914 - 0.8307	0.472	5.512	7.874	0.750	20	6	5
0.8308 - 0.8701	0.472	5.512	7.874	0.750	20	6	6
0.8702 - 0.9094	0.472	5.512	7.874	0.750	20	6	6
0.9095 - 0.9488	0.472	5.512	7.874	0.750	20	6	6
0.9489 - 0.9882	0.472	5.512	7.874	0.750	20	6	6
0.9883 - 1.0276	0.472	5.906	8.268	1.000	25	6	6
1.0277 - 1.0669	0.551	5.906	8.268	1.000	25	6	6
1.0670 - 1.1063	0.551	5.906	8.268	1.000	25	6	8
1.1064 - 1.1457	0.551	5.906	8.268	1.000	25	6	8
1.1458 - 1.1850	0.551	5.906	8.268	1.000	25	6	8
1.1851 - 1.2244	0.551	5.906	8.268	1.000	25	6	8
1.2245 - 1.2638	0.551	5.906	8.268	1.000	25	6	8

The diameter of the guide area is 0.0004" - 0.0006" below the reamer diameter.
 Tempered guide tools are capable of speeds up to 130 SFM.
 Tool recommended with carbide substrate only AND only a through hole application.



ALVAN[®] Monobloc Reamers

Short Length

Helical Flute

RADIAL COOLANT - THROUGH HOLES

Inch Shank - Series 93627

Metric Shank - Series 3627

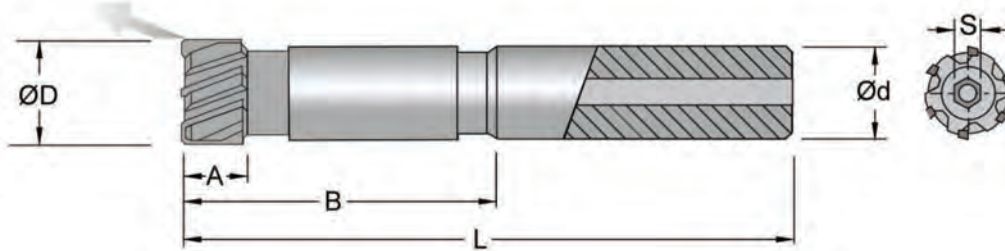

ØD (inch)	A (inch)	B (inch)	L (inch)	Series 93627	Series 3627	Number of Teeth	Hex Key S (mm)
				Ød ^{h7} (inch)	Ød ^{h7} (mm)		S (mm)
0.2283 - 0.2598	0.315	1.575	3.150	0.500	12	4	2
0.2599 - 0.2992	0.315	1.575	3.150	0.500	12	4	2
0.2993 - 0.3386	0.394	1.575	3.150	0.500	12	4	2.5
0.3387 - 0.3780	0.394	1.969	3.543	0.500	12	4	2.5
0.3781 - 0.4173	0.394	1.969	3.740	0.500	12	6	3
0.4174 - 0.4567	0.394	2.362	4.134	0.500	12	6	3
0.4568 - 0.4961	0.394	2.362	4.134	0.500	12	6	3
0.4962 - 0.5354	0.394	2.362	4.134	0.500	12	6	4
0.5355 - 0.5748	0.394	2.756	4.528	0.500	12	6	4
0.5749 - 0.6142	0.394	2.756	4.528	0.500	12	6	4
0.6143 - 0.6535	0.394	3.150	5.118	0.625	16	6	4
0.6536 - 0.6929	0.394	3.150	5.118	0.625	16	6	5
0.6930 - 0.7323	0.472	3.543	5.512	0.625	16	6	5
0.7324 - 0.7520	0.472	3.543	5.906	0.750	20	6	5
0.7521 - 0.7913	0.472	3.937	6.299	0.750	20	6	5
0.7914 - 0.8307	0.472	3.937	6.299	0.750	20	6	5
0.8308 - 0.8701	0.472	3.937	6.299	0.750	20	6	6
0.8702 - 0.9094	0.472	3.937	6.299	0.750	20	6	6
0.9095 - 0.9488	0.472	3.937	6.299	0.750	20	6	6
0.9489 - 0.9882	0.472	3.937	6.299	0.750	20	6	6
0.9883 - 1.0276	0.472	4.331	6.693	1.000	25	6	6
1.0277 - 1.0669	0.551	4.331	6.693	1.000	25	6	6
1.0670 - 1.1063	0.551	4.331	6.693	1.000	25	6	8
1.1064 - 1.1457	0.551	4.331	6.693	1.000	25	6	8
1.1458 - 1.1850	0.551	4.331	6.693	1.000	25	6	8
1.1851 - 1.2244	0.551	4.331	6.693	1.000	25	6	8
1.2245 - 1.2638	0.551	4.331	6.693	1.000	25	6	8

ALVAN® Monobloc Reamers

Long Length

Helical Flute



RADIAL COOLANT - THROUGH HOLES

Inch Shank - Series 93617

Metric Shank - Series 3617

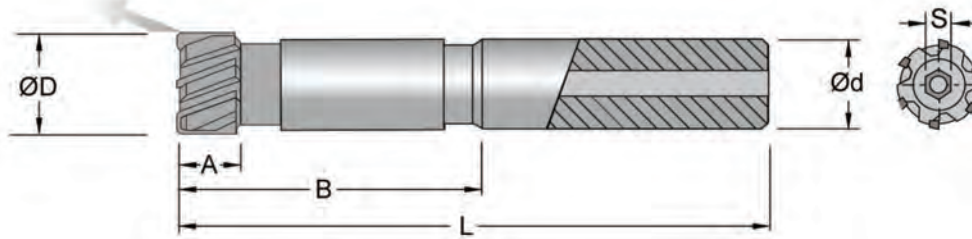

ØD (inch)	A (inch)	B (inch)	L (inch)	Series 93617	Series 3617	Number of Teeth	Hex Key S (mm)
				Ød ^{h7} (inch)	Ød ^{h7} (mm)		S (mm)
0.2283 - 0.2598	0.315	3.346	4.843	0.500	12	4	2
0.2599 - 0.2992	0.315	3.346	4.843	0.500	12	4	2
0.2993 - 0.3386	0.394	3.346	4.843	0.500	12	4	2.5
0.3387 - 0.3780	0.394	3.346	4.843	0.500	12	4	2.5
0.3781 - 0.4173	0.394	4.528	6.299	0.500	12	6	3
0.4174 - 0.4567	0.394	4.528	6.299	0.500	12	6	3
0.4568 - 0.4961	0.394	4.528	6.299	0.500	12	6	3
0.4962 - 0.5354	0.394	4.528	6.299	0.500	12	6	4
0.5355 - 0.5748	0.394	4.528	6.299	0.500	12	6	4
0.5749 - 0.6142	0.394	4.528	6.299	0.500	12	6	4
0.6143 - 0.6535	0.394	5.118	7.087	0.625	16	6	4
0.6536 - 0.6929	0.394	5.118	7.087	0.625	16	6	5
0.6930 - 0.7323	0.472	5.118	7.087	0.625	16	6	5
0.7324 - 0.7520	0.472	5.512	7.874	0.750	20	6	5
0.7521 - 0.7913	0.472	5.512	7.874	0.750	20	6	5
0.7914 - 0.8307	0.472	5.512	7.874	0.750	20	6	5
0.8308 - 0.8701	0.472	5.512	7.874	0.750	20	6	6
0.8702 - 0.9094	0.472	5.512	7.874	0.750	20	6	6
0.9095 - 0.9488	0.472	5.512	7.874	0.750	20	6	6
0.9489 - 0.9882	0.472	5.512	7.874	0.750	20	6	6
0.9883 - 1.0276	0.472	5.906	8.268	1.000	25	6	6
1.0277 - 1.0669	0.551	5.906	8.268	1.000	25	6	6
1.0670 - 1.1063	0.551	5.906	8.268	1.000	25	6	8
1.1064 - 1.1457	0.551	5.906	8.268	1.000	25	6	8
1.1458 - 1.1850	0.551	5.906	8.268	1.000	25	6	8
1.1851 - 1.2244	0.551	5.906	8.268	1.000	25	6	8
1.2245 - 1.2638	0.551	5.906	8.268	1.000	25	6	8

ALVAN® Monobloc Reamers



ALVAN[®] Reamers

Troubleshooting Guide

Problem	Possible Cause	Possible Solution
Oversize hole	<ul style="list-style-type: none"> a.) The reamer is running eccentric to the center of the machine spindle b.) Excessive misalignment causing reamer to cut on back taper c.) Material build up on cutting edges d.) The reamer diameter is too large 	<ul style="list-style-type: none"> a.) Use the modular system with radial adjustment b.) Rectify misalignment c.) Replace the coolant or change the cutting speed d.) Use smaller reamer or regrind existing one
Undersize hole	<ul style="list-style-type: none"> a.) The reamer diameter is too small b.) The reamer diameter is worn c.) The coolant is not suitable d.) Stock allowance too small e.) The cutting speed is too low 	<ul style="list-style-type: none"> a.) Use larger reamer b.) Expand, regrind or replace the reamer c.) Replace the coolant d.) Increase the stock allowance e.) Increase the cutting speed
Tapered hole	<ul style="list-style-type: none"> a.) Excessive misalignment 	<ul style="list-style-type: none"> a.) Correct misalignment
Burr at the entry of the hole	<ul style="list-style-type: none"> a.) Excessive misalignment 	<ul style="list-style-type: none"> a.) Correct misalignment
The hole is not straight	<ul style="list-style-type: none"> a.) Concentricity and alignment error between the workpiece and the tool b.) Asymmetrical cutting or angled surfaces 	<ul style="list-style-type: none"> a.) Correct misalignment and use the modular system with radial adjustment b.) Create a chamfer on the lead-in
Poor hole finish	<ul style="list-style-type: none"> a.) One cutting edge is chipped b.) The lead-in is irregular c.) Back taper on the cutting edges too great d.) Excessive misalignment e.) Cutting data not correct f.) Poor chip evacuation 	<ul style="list-style-type: none"> a.) Regrind the reamer b.) Regrind the reamer c.) Regrind the reamer d.) Correct misalignment or use the modular system e.) Verify cutting data f.) Verify coolant volume and pressure or use through tool coolant
The reamer creates excessive torque loading	<ul style="list-style-type: none"> a.) Back taper on the cutting edges too small b.) The radially ground land is too wide c.) The coolant is not suitable 	<ul style="list-style-type: none"> a.) Regrind the reamer b.) Regrind the reamer c.) Replace the coolant

Cutting Rings

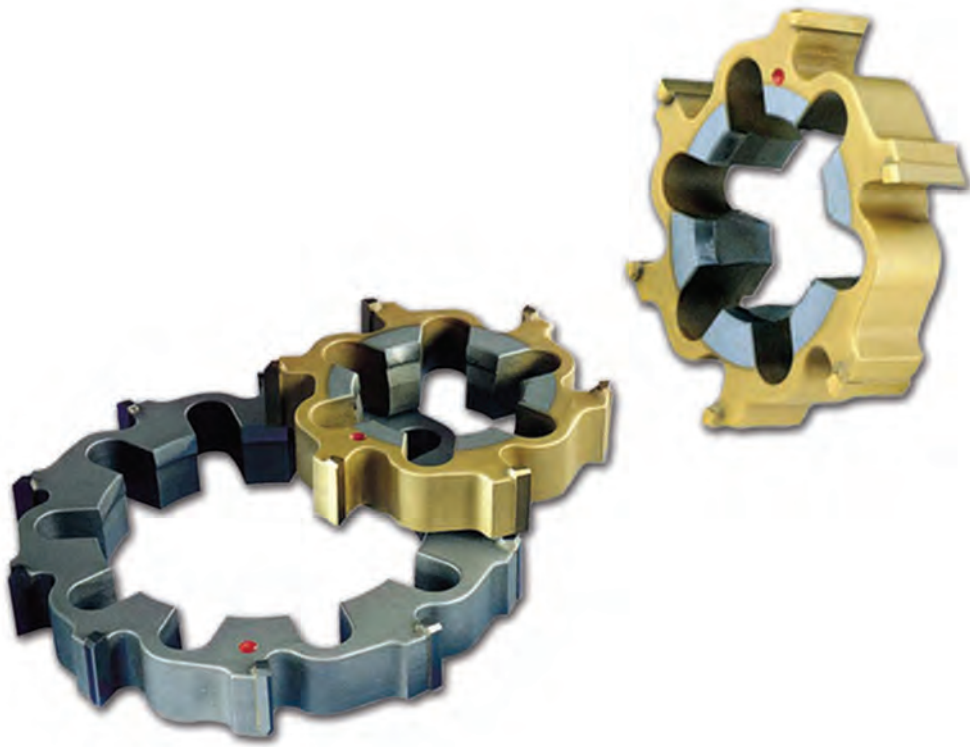

- Diameter range from 0.6929" - 7.8975"
(17,60 mm - 200,60 mm)
- Expandable design allows for up to 4% adjustment of diameter
- Capable of holding extremely tight hole tolerance (0.0002" (0,005 mm))
- Available coated and uncoated with Carbide, Cermet, PCD and CBN cutting edges
- Several leads provide tailored solution for each application



ALVAN® Cutting Ring Item Descriptions

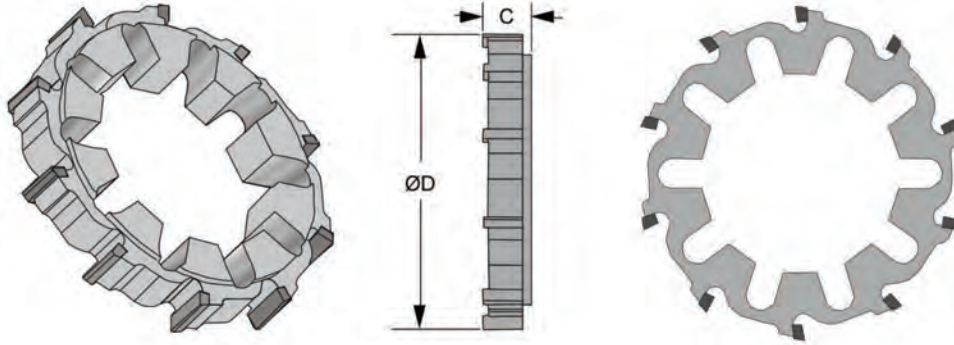

ØD (inch)	ØD (mm)	C (inch)	Number of Teeth
0.6929 - 0.8503	17,600 - 21,599	0.433	6
0.8504 - 1.0078	21,600 - 25,599	0.472	6
1.0079 - 1.2834	25,600 - 32,599	0.551	6
1.2835 - 1.7952	32,600 - 45,599	0.630	6
1.7953 - 3.1338	45,600 - 79,599	0.728	6
3.1339 - 3.9605	79,600 - 100,599	0.728	8
3.9606 - 4.3542	100,600 - 110,599	0.728	10
4.3543 - 7.8975	110,600 - 200,600	0.728	12

ALVAN® Cutting Rings are compatible with all ring arbors shown on pages 32 - 45

CODE	DESCRIPTION
2000 - CTx - Ø	Uncoated K10 Carbide Cutting Edges
2TIN - CTx - Ø	TiN Coated K10 Carbide Cutting Edges
2TIC - CTx - Ø	TiCN Coated K10 Carbide Cutting Edges
2TIA - CTx - Ø	TiAlN Coated K10 Carbide Cutting Edges
2000 - KTx - Ø	Uncoated K01 Carbide Cutting Edges
2TIN - KTx - Ø	TiN Coated K01 Carbide Cutting Edges
2TIC - KTx - Ø	TiCN Coated K01 Carbide Cutting Edges
2TIA - KTx - Ø	TiAlN Coated K01 Carbide Cutting Edges
2AVC - CTx - Ø	Uncoated P05 Cermet Cutting Edges
2ANC - CTx - Ø	TiN Coated P05 Cermet Cutting Edges
2ACC - CTx - Ø	TiCN Coated P05 Cermet Cutting Edges
2AAC - CTx - Ø	TiAlN Coated P05 Cermet Cutting Edges
2AVC - STx - Ø	Uncoated P01 Cermet Cutting Edges
2ANC - STx - Ø	TiN Coated P01 Cermet Cutting Edges
2ACC - STx - Ø	TiCN Coated P01 Cermet Cutting Edges
2AAC - STx - Ø	TiAlN Coated P01 Cermet Cutting Edges

- **K01 Carbide is more wear resistant than K10 Carbide and may provide improved tool life in abrasive materials**
- **P01 Cermet is more wear resistant than P05 Cermet and may provide improved tool life in abrasive materials**

Ordering Examples:

For reaming a .7500" (+.0000, -.0005") diameter hole using a cutting ring with TiN coated K01 carbide cutting edges and negative lead, use the following code:

I2TIN-KTN-007500+0000-0005

For reaming a 20.5mm (+0.008mm, -0.000mm) diameter hole using a cutting ring with uncoated P01 cermet and 45° lead, use the following code:

2AVC-STG-020500+008-000

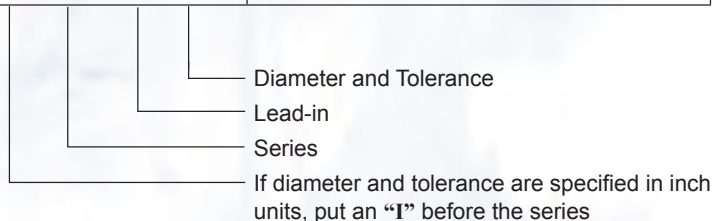

* Minimum total tolerance capable is 0.0002" (0,005mm)

ALVAN® Cutting Rings

Lead Angle Descriptions



Left Hand Helical Flute Leads

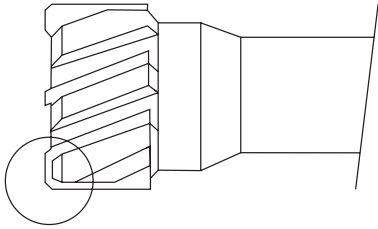

Left hand helical flute cutting rings from diameter 1.2835" to 7.8972"

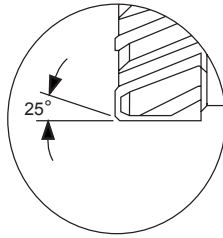

"E" lead-in (left hand helical flutes) is standard and suitable for most materials (only through hole)

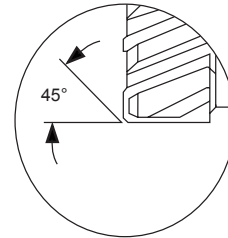

"M" lead-in (left hand helical flutes) may provide better penetration rates in steels over 200 BHN (only through hole)

Straight Flute Leads

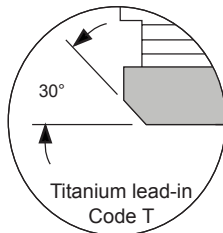
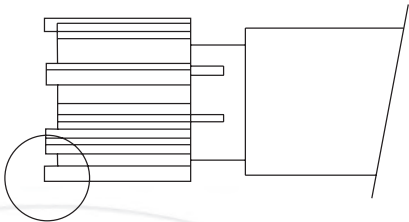

"T" lead-in is suitable for titanium based alloys

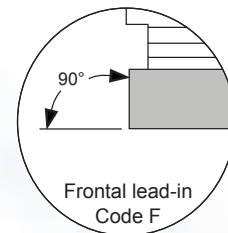

"F" lead-in can be used for stock removal at the bottom of the hole. Reduce the feed by 40% of the values on pages 47-50 ("Y" lead with chipbreaker)

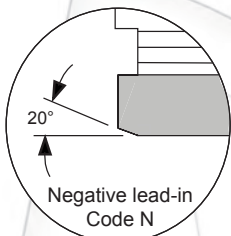

"N" lead-in is ideal for through holes. It is possible to increase the feed up to 100% of the values on pages 47-50

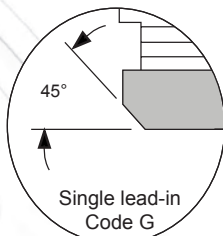

"G" lead-in is standard and suitable for most materials ("X" lead with chipbreaker)

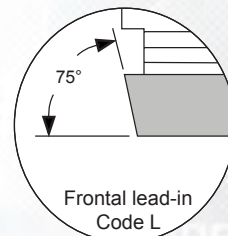

"L" lead-in may provide improved straightness. Reduce the feed by 40% of the values on pages 47-50 ("W" lead with chipbreaker)

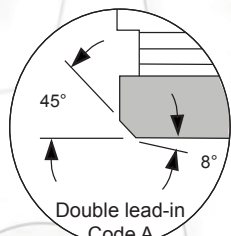

"A" lead-in can be used to improve finish

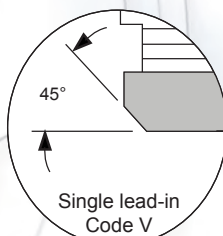

"V" lead-in is suitable for most materials and increases tool life ("J" lead with chipbreaker)



ALVAN® Ring Arbors

Short Length

Rear Adjusting

NO COOLANT - THROUGH HOLES

Inch Shank - Series 92530

Metric Shank - Series 2530

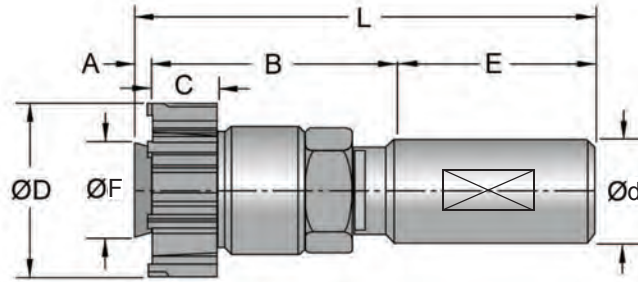

ØD (inch)	ØF (inch)	A (inch)	B (inch)	C (inch)	E (inch)	L (inch)	Series 92530	Series 2530	Number of Teeth
							Ød ^{h7} (inch)	Ød ^{h7} (mm)	
0.6929 - 0.8503	0.472	0.118	2.008	0.433	1.575	3.583	0.625	16	6
0.8504 - 1.0078	0.472	0.118	2.008	0.472	1.575	3.583	0.625	16	6
1.0079 - 1.2834	0.622	0.138	2.008	0.551	1.575	3.583	0.750	20	6
1.2835 - 1.5983	0.843	0.177	2.008	0.630	1.575	3.583	0.750	20	6
1.5984 - 1.7952	1.004	0.177	2.165	0.630	1.417	3.583	1.000	25	6

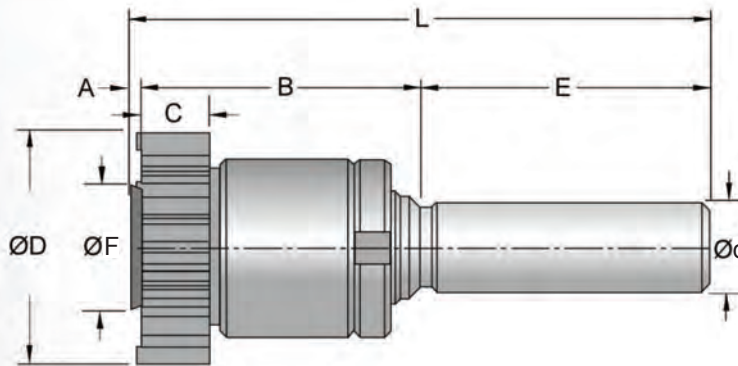

ØD (inch)	ØF (inch)	A (inch)	B (inch)	C (inch)	E (inch)	L (inch)	Series 92530	Series 2530	Number of Teeth
							Ød ^{h7} (inch)	Ød ^{h7} (mm)	
1.7953 - 2.3857	1.181	0.295	2.441	0.728	2.559	5.000	0.750	20	6
2.3858 - 3.1338	1.575	0.413	2.835	0.728	2.559	5.394	1.000	25	6
3.1339 - 3.9602	2.244	0.492	3.346	0.728	2.559	5.906	1.500	40	8

Arbors can be made with or without a Shank Flat.

ALVAN® Ring Arbors Spare Parts



NO COOLANT - THROUGH HOLES	Inch Shank - Series 92530	Metric Shank - Series 2530
----------------------------	---------------------------	----------------------------

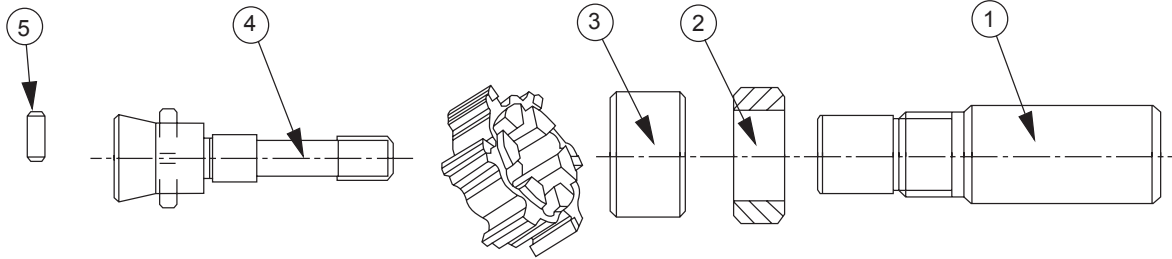

ØD (inch)	Series 92530 Inch Shank		Series 2530 Metric Shank		Nut 2	Bushing 3	Conical Screw with Drive Pin 4	Conical Screw with Drive Pin Second Expansion 4	Drive Pin 5
	Complete Mandrel without Cut- ting Ring	Mandrel 1	Complete Mandrel without Cutting Ring	Mandrel 1					
0.6929 - 0.8503	92531-MC-010	92531-MA-010	2531-MC-010	2531-MA-010	2501-DA-010	2501-BU-010	2501-VI-016	2501-VI-019	2501-CO-010
0.8504 - 1.0078	92531-MC-020	92531-MA-020	2531-MC-020	2531-MA-020	2501-DA-020	2501-BU-020	2501-VI-026	2501-VI-029	2501-CO-020
1.0079 - 1.2834	92531-MC-030	92531-MA-030	2531-MC-030	2531-MA-030	2501-DA-030	2501-BU-030	2501-VI-036	2501-VI-039	2501-CO-030
1.2835 - 1.5983	92531-MC-040	92531-MA-040	2531-MC-040	2531-MA-040	2501-DA-040	2501-BU-040	2501-VI-046	2501-VI-049	2501-CO-040
1.5984 - 1.7952	92531-MC-050	92531-MA-050	2531-MC-050	2531-MA-050	2501-DA-050	2501-BU-050	2501-VI-056	2501-VI-059	2501-CO-050

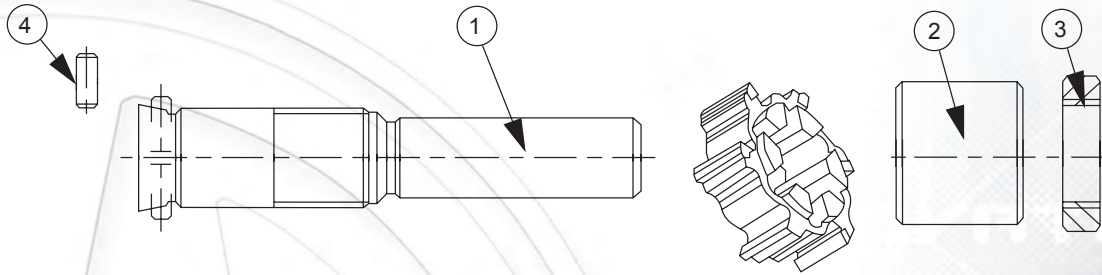

ØD (inch)	Series 92530 Inch Shank		Series 2530 Metric Shank		Bushing 2	Ring Nut 3	Drive Pin 4
	Complete Mandrel without Cutting Ring	Mandrel with Drive Pin 1	Complete Mandrel without Cutting Ring	Mandrel with Drive Pin 1			
1.7953 - 2.3857	92530-MC-060	92530-MA-060	2530-MC-060	2530-MA-060	2500-BU-060	2500-GH-060	2500-CO-060
2.3858 - 3.1338	92530-MC-070	92530-MA-070	2530-MC-070	2530-MA-070	2500-BU-070	2500-GH-070	2500-CO-070
3.1339 - 3.9602	92530-MC-080	92530-MA-080	2530-MC-080	2530-MA-080	2500-BU-080	2500-GH-080	2500-CO-080

Arbors can be made with or without a Shank Flat.

ALVAN® Cutting Rings



ALVAN® Ring Arbors

Short Length

Rear Adjusting

NO COOLANT - BLIND HOLES	Inch Shank - Series 92535	Metric Shank - Series 2535
--------------------------	---------------------------	----------------------------

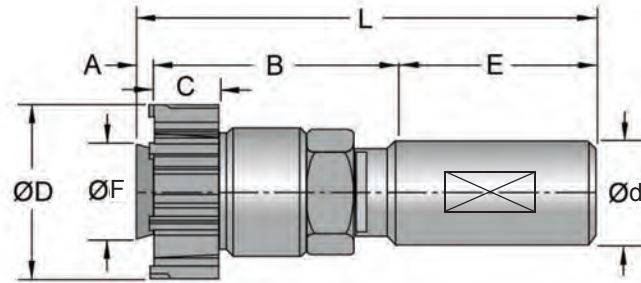

ØD (inch)	ØF (inch)	A (inch)	B (inch)	C (inch)	E (inch)	L (inch)	Series 92530	Series 2530	Number of Teeth
							Ød ^{h7} (inch)	Ød ^{h7} (mm)	
0.6929 - 0.8503	0.441	0.039	2.008	0.433	1.575	3.583	0.625	16	6
0.8504 - 1.0078	0.441	0.039	2.008	0.472	1.575	3.583	0.625	16	6
1.0079 - 1.2834	0.598	0.039	2.008	0.551	1.575	3.583	0.750	20	6
1.2835 - 1.5983	0.799	0.039	2.008	0.630	1.575	3.583	0.750	20	6
1.5984 - 1.7952	0.949	0.039	2.165	0.630	1.417	3.583	1.000	25	6

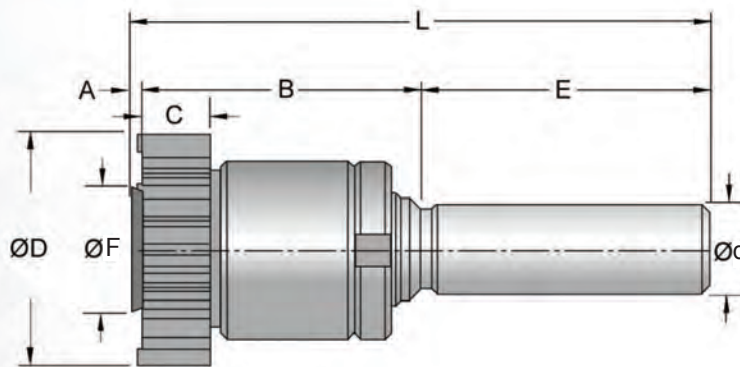

ØD (inch)	ØF (inch)	A (inch)	B (inch)	C (inch)	E (inch)	L (inch)	Series 92535	Series 2535	Number of Teeth
							Ød ^{h7} (inch)	Ød ^{h7} (mm)	
1.7953 - 2.3857	1.094	0.059	2.441	0.728	2.559	5.000	0.750	20	6
2.3858 - 3.1338	1.457	0.059	2.835	0.728	2.559	5.394	1.000	25	6
3.1339 - 3.9602	2.094	0.059	3.346	0.728	2.559	5.906	1.500	40	8

ALVAN® Ring Arbors Spare Parts



NO COOLANT - BLIND HOLES	Inch Shank - Series 92535	Metric Shank - Series 2535
--------------------------	---------------------------	----------------------------

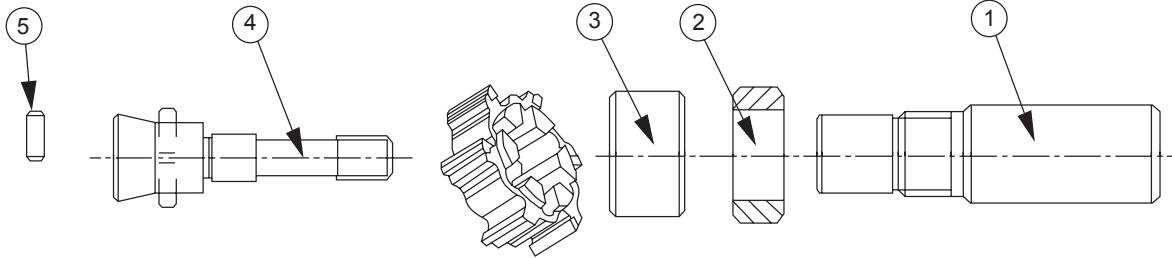

ØD (inch)	Series 92530 Inch Shank		Series 2530 Metric Shank		Nut 2	Bushing 3	Conical Screw with Drive Pin 4	Conical Screw with Drive Pin Second Expansion 4	Drive Pin 5
	Complete Mandrel without Cutting Ring	Mandrel 1	Complete Mandrel without Cutting Ring	Mandrel 1					
0.6929 - 0.8503	92531-MC-015	92531-MA-010	2531-MC-015	2531-MA-010	2501-DA-010	2501-BU-010	2501-VI-017	2501-VI-018	2501-CO-010
0.8504 - 1.0078	92531-MC-025	92531-MA-020	2531-MC-025	2531-MA-020	2501-DA-020	2501-BU-020	2501-VI-027	2501-VI-028	2501-CO-020
1.0079 - 1.2834	92531-MC-035	92531-MA-030	2531-MC-035	2531-MA-030	2501-DA-030	2501-BU-030	2501-VI-037	2501-VI-038	2501-CO-030
1.2835 - 1.5983	92531-MC-045	92531-MA-040	2531-MC-045	2531-MA-040	2501-DA-040	2501-BU-040	2501-VI-047	2501-VI-048	2501-CO-040
1.5984 - 1.7952	92531-MC-055	92531-MA-050	2531-MC-055	2531-MA-050	2501-DA-050	2501-BU-050	2501-VI-057	2501-VI-058	2501-CO-050

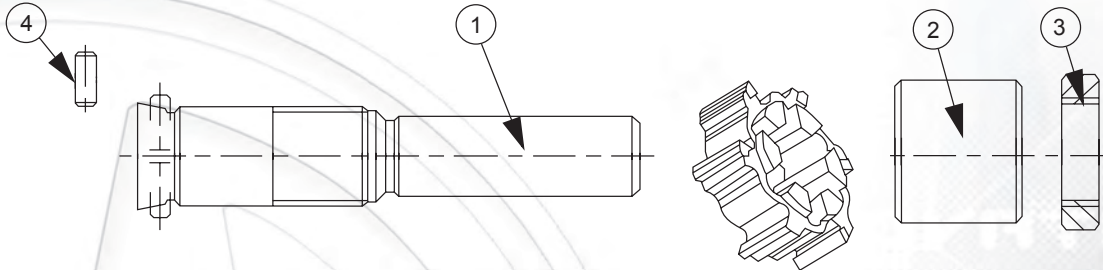

ØD (inch)	Series 92530 Inch Shank			Series 2530 Metric Shank			Bushing 2	Ring Nut 3	Drive Pin 4
	Complete Mandrel without Cutting Ring	Mandrel with Drive Pin 1	Mandrel Second Expansion 1	Complete Mandrel without Cutting Ring	Mandrel with Drive Pin 1	Mandrel Second Expansion 1			
1.7953 - 2.3857	92530-MC-065	92530-MA-065	92530-MA-066	2530-MC-065	2530-MA-065	2530-MA-066	2500-BU-060	2500-GH-060	2500-CO-060
2.3858 - 3.1338	92530-MC-075	92530-MA-075	92530-MA-076	2530-MC-075	2530-MA-075	2530-MA-076	2500-BU-070	2500-GH-070	2500-CO-070
3.1339 - 3.9602	92530-MC-085	92530-MA-085	92530-MA-086	2530-MC-085	2530-MA-085	2530-MA-086	2500-BU-080	2500-GH-080	2500-CO-080

ALVAN® Cutting Rings



ALVAN® Ring Arbors

Short Length

Front Adjusting

RADIAL COOLANT - THROUGH HOLES

Inch Shank - Series 94550

Metric Shank - Series 4550

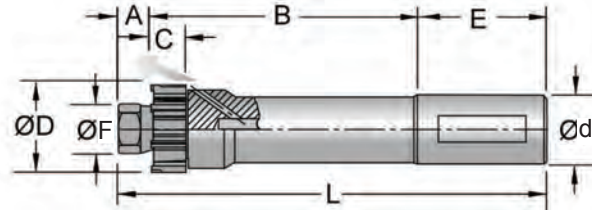

ØD (inch)	ØF (inch)	A (inch)	B (inch)	C (inch)	E (inch)	L (inch)	Series 94550	Series 4550	Number of Teeth
							Ød ^{H7} (inch)	Ød ^{H7} (mm)	
0.6929 - 0.8503	0.472	0.433	3.189	0.433	1.969	5.591	0.750	20	6
0.8504 - 1.0078	0.472	0.433	3.189	0.472	1.969	5.591	0.750	20	6
1.0079 - 1.2834	0.614	0.433	4.016	0.551	1.969	6.417	0.750	20	6
1.2835 - 1.5983	0.866	0.551	4.016	0.630	2.205	6.772	1.000	25	6
1.5984 - 1.7952	1.000	0.591	4.016	0.630	2.205	6.811	1.000	25	6
1.7953 - 2.3857	1.181	0.807	4.134	0.728	2.362	7.303	1.250	32	6
2.3858 - 3.1338	1.575	0.965	4.134	0.728	2.362	7.461	1.250	32	6
3.1339 - 3.9602	2.205	1.122	4.134	0.728	2.756	8.012	1.500	40	6

SPARE PARTS

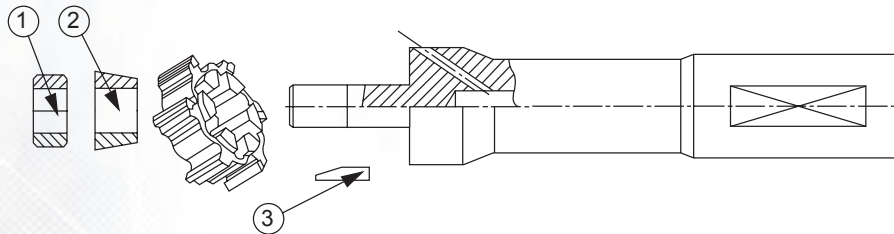

ØD (inch)	Series 94550 Inch Shank	Series 4550 Metric Shank	Nut 1	Conical Ring 2	Drive Pin 3
	Complete Mandrel without Cutting Ring	Complete Mandrel without Cutting Ring			
0.6929 - 0.8503	94550-MC-010	4550-MC-010	2000-DA-010	2010-AC-010	2000-CO-010
0.8504 - 1.0078	94550-MC-020	4550-MC-020	2000-DA-010	2010-AC-010	2000-CO-020
1.0079 - 1.1653	94550-MC-030	4550-MC-030	2000-DA-020	2010-AC-020	2000-CO-030
1.2835 - 1.4408	94550-MC-040	4550-MC-040	2000-DA-060	2010-AC-030	2000-CO-040
1.5984 - 1.7952	94550-MC-050	4550-MC-050	2000-DA-090	2010-AC-040	2000-CO-060
1.7953 - 1.9527	94550-MC-060	4550-MC-060	2000-GH-880	2010-AC-050	2000-CO-060
1.9528 - 2.1889	94550-MC-070	4550-MC-070	2000-GH-880	2010-AC-050	2000-CO-070
2.3858 - 2.5826	94550-MC-080	4550-MC-080	2000-GH-900	2010-AC-060	2000-CO-080
2.7795 - 3.1338	94550-MC-090	4550-MC-090	2000-GH-900	2010-AC-060	2000-CO-090
3.1339 - 3.5668	94550-MC-100	4550-MC-100	2000-GH-920	2010-AC-070	2000-CO-090
3.5669 - 3.9602	94550-MC-110	4550-MC-110	2000-GH-920	2010-AC-070	2000-CO-090

Arbors can be made with or without a Shank Flat.

ALVAN® Ring Arbors

Short Length

Front Adjusting



RADIAL COOLANT - BLIND HOLES	Inch Shank - Series 94555	Metric Shank - Series 4555
------------------------------	---------------------------	----------------------------

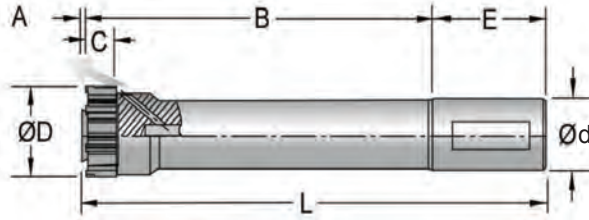

ØFD (inch)	A (inch)	B (inch)	C (inch)	E (inch)	L (inch)	Series 94555	Series 4555	Number of Teeth
						Ød ^{h7} (inch)	Ød ^{h7} (mm)	
0.6929 - 0.8503	0.039	3.189	0.433	1.969	5.197	0.750	20	6
0.8504 - 1.0078	0.039	3.189	0.472	1.969	5.197	0.750	20	6
1.0079 - 1.2834	0.039	4.016	0.551	1.969	6.024	0.750	20	6
1.2835 - 1.5983	0.039	4.016	0.630	2.205	6.260	1.000	25	6
1.5984 - 1.7952	0.039	4.016	0.630	2.205	6.260	1.000	25	6
1.7953 - 2.3857	0.059	4.134	0.728	2.362	6.555	1.250	32	6
2.3858 - 3.1338	0.059	4.134	0.728	2.362	6.555	1.250	32	6
3.1339 - 3.9602	0.059	4.134	0.728	2.756	6.949	1.500	40	8

SPARE PARTS

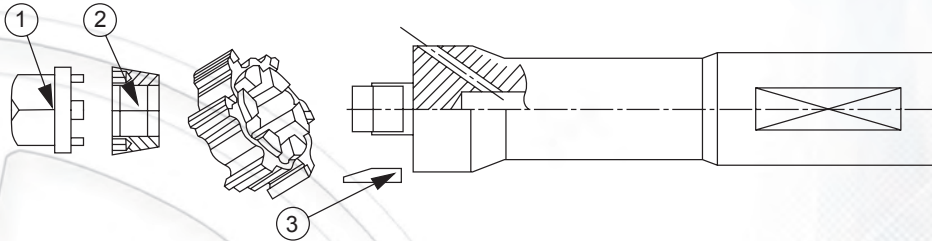

ØD (inch)	Series 94550 Inch Shank	Series 4550 Metric Shank	Adjusting Key	Conical Ring	Conical Ring Second Expansion	Conical Ring Third Expansion	Drive Pin
	Complete Mandrel without Cutting Ring	Complete Mandrel without Cutting Ring					
0.6929 - 0.8503	94555-MC-010	4555-MC-010	4001-CH-015	4001-AC-115	4001-AC-215	-	2000-CO-010
0.8504 - 1.0078	94555-MC-020	4555-MC-020	4001-CH-015	4001-AC-115	4001-AC-215	-	2000-CO-020
1.0079 - 1.1653	94555-MC-030	4555-MC-030	4001-CH-025	4001-AC-125	4001-AC-225	4001-AC-325	2000-CO-030
1.1654 - 1.2834	94555-MC-035	4555-MC-035	4001-CH-025	4001-AC-125	4001-AC-225	4001-AC-325	2000-CO-040
1.2835 - 1.4408	94555-MC-040	4555-MC-040	4001-CH-035	4001-AC-135	4001-AC-235	4001-AC-335	2000-CO-040
1.4409 - 1.5983	94555-MC-045	4555-MC-045	4001-CH-035	4001-AC-135	4001-AC-235	4001-AC-335	2000-CO-050
1.5984 - 1.7952	94555-MC-050	4555-MC-050	4001-CH-045	4001-AC-145	4001-AC-245	4001-AC-345	2000-CO-060
1.7953 - 1.9527	94555-MC-060	4555-MC-060	4001-CH-055	4001-AC-155	4001-AC-255	4001-AC-355	2000-CO-060
1.9528 - 2.1889	94555-MC-070	4555-MC-070	4001-CH-055	4001-AC-155	4001-AC-255	4001-AC-355	2000-CO-070
2.1890 - 2.3857	94555-MC-075	4555-MC-075	4001-CH-055	4001-AC-155	4001-AC-255	4001-AC-355	2000-CO-080
2.3858 - 2.5826	94555-MC-080	4555-MC-080	4001-CH-065	4001-AC-165	4001-AC-265	4001-AC-365	2000-CO-080
2.5827 - 2.7794	94555-MC-085	4555-MC-085	4001-CH-065	4001-AC-165	4001-AC-265	4001-AC-365	2000-CO-090
2.7795 - 3.1338	94555-MC-090	4555-MC-090	4001-CH-065	4001-AC-165	4001-AC-265	4001-AC-365	2000-CO-090
3.1339 - 3.5668	94555-MC-100	4555-MC-100	4001-CH-085	4001-AC-185	4001-AC-285	4001-AC-385	2000-CO-090
3.5669 - 3.9602	94555-MC-110	4555-MC-110	4001-CH-085	4001-AC-185	4001-AC-285	4001-AC-385	2000-CO-090

Arbors can be made with or without a Shank Flat.



ALVAN® Ring Arbors

Long Length

Front Adjusting

RADIAL COOLANT - THROUGH HOLES	Inch Shank - Series 94500	Metric Shank - Series 4500
--------------------------------	---------------------------	----------------------------

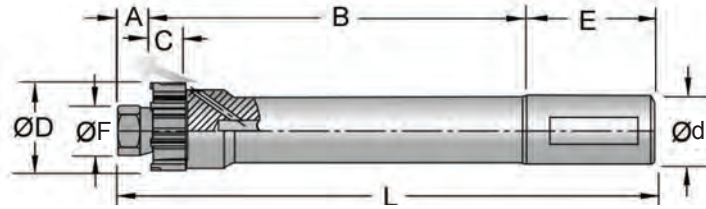

ØD (inch)	ØF (inch)	A (inch)	B (inch)	C (inch)	E (inch)	L (inch)	Series 94500	Series 4500	Number of Teeth
							Ød ^{h7} (inch)	Ød ^{h7} (mm)	
0.6929 - 0.8503	0.472	0.433	4.764	0.433	1.969	7.165	0.750	20	6
0.8504 - 1.0078	0.472	0.433	4.764	0.472	1.969	7.165	0.750	20	6
1.0079 - 1.2834	0.614	0.433	6.024	0.551	1.969	8.425	0.750	20	6
1.2835 - 1.5983	0.866	0.551	7.047	0.630	2.205	9.803	1.000	25	6
1.5984 - 1.7952	1.000	0.591	7.913	0.630	2.205	10.709	1.000	25	6
1.7953 - 2.3857	1.181	0.807	8.425	0.728	2.362	11.594	1.250	32	6
2.3858 - 3.1338	1.575	0.965	9.331	0.728	2.362	12.657	1.250	32	6
3.1339 - 3.9602	2.205	1.122	9.646	0.728	2.756	13.524	1.500	40	8

SPARE PARTS

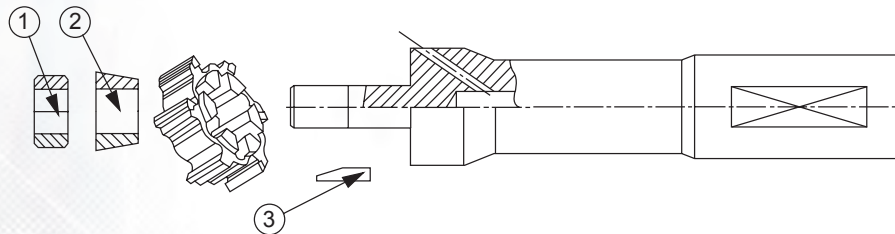

ØD (inch)	Series 94500 Inch Shank	Series 4500 Metric Shank	Nut 1	Conical Ring 2	Drive Pin 3
	Complete Mandrel without Cutting Ring	Complete Mandrel without Cutting Ring			
0.6929 - 0.8503	94500-MC-010	4500-MC-010	2000-DA-010	2010-AC-010	2000-CO-010
0.8504 - 1.0078	94500-MC-020	4500-MC-020	2000-DA-010	2010-AC-010	2000-CO-020
1.0079 - 1.1653	94500-MC-030	4500-MC-030	2000-DA-020	2010-AC-020	2000-CO-030
1.2835 - 1.4408	94500-MC-040	4500-MC-040	2000-DA-060	2010-AC-030	2000-CO-040
1.5984 - 1.7952	94500-MC-050	4500-MC-050	2000-DA-090	2010-AC-040	2000-CO-060
1.7953 - 1.9527	94500-MC-060	4500-MC-060	2000-GH-880	2010-AC-050	2000-CO-060
1.9528 - 2.1889	94500-MC-070	4500-MC-070	2000-GH-880	2010-AC-050	2000-CO-070
2.3858 - 2.5826	94500-MC-080	4500-MC-080	2000-GH-900	2010-AC-060	2000-CO-080
2.7795 - 3.1338	94500-MC-090	4500-MC-090	2000-GH-900	2010-AC-060	2000-CO-090
3.1339 - 3.5668	94500-MC-100	4500-MC-100	2000-GH-920	2010-AC-070	2000-CO-090
3.5669 - 3.9602	94500-MC-110	4500-MC-110	2000-GH-920	2010-AC-070	2000-CO-090

Arbors can be made with or without a Shank Flat.

ALVAN® Ring Arbors

Long Length

Front Adjusting



RADIAL COOLANT - BLIND HOLES	Inch Shank - Series 94505	Metric Shank - Series 4505
------------------------------	---------------------------	----------------------------

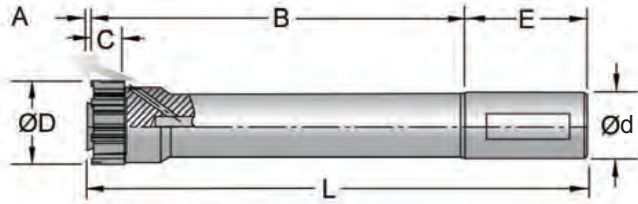

ØD (inch)	A (inch)	B (inch)	C (inch)	E (inch)	L (inch)	Series 94505	Series 4505	Number of Teeth
						Ø _d ^{h7} (inch)	Ø _d ^{h7} (mm)	
0.6929 - 0.8503	0.039	4.764	0.433	1.969	6.772	0.750	20	6
0.8504 - 1.0078	0.039	4.764	0.472	1.969	6.772	0.750	20	6
1.0079 - 1.2834	0.039	6.024	0.551	1.969	8.031	0.750	20	6
1.2835 - 1.5983	0.039	7.047	0.630	2.205	9.291	1.000	25	6
1.5984 - 1.7952	0.039	7.913	0.630	2.205	10.157	1.000	25	6
1.7953 - 2.3857	0.059	8.425	0.728	2.362	10.846	1.250	32	6
2.3858 - 3.1338	0.059	9.331	0.728	2.362	11.752	1.250	32	6
3.1339 - 3.9602	0.059	9.646	0.728	2.756	12.461	1.500	40	8

SPARE PARTS

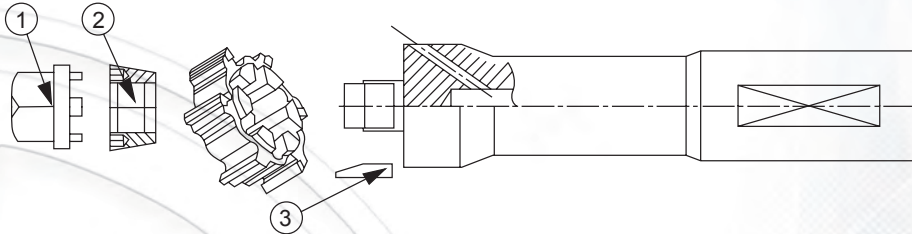

ØD (inch)	Series 94505 Inch Shank	Series 4505 Metric Shank	Adjusting Key 1	Conical Ring 2	Conical Ring Second Expansion 2	Conical Ring Third Expansion 2	Drive Pin 3
	Complete Mandrel without Cutting Ring	Complete Mandrel without Cutting Ring					
0.6929 - 0.8503	94505-MC-010	4505-MC-010	4001-CH-015	4001-AC-115	4001-AC-215	-	2000-CO-010
0.8504 - 1.0078	94505-MC-020	4505-MC-020	4001-CH-015	4001-AC-115	4001-AC-215	-	2000-CO-020
1.0079 - 1.1653	94505-MC-030	4505-MC-030	4001-CH-025	4001-AC-125	4001-AC-225	4001-AC-325	2000-CO-030
1.1654 - 1.2834	94505-MC-035	4505-MC-035	4001-CH-025	4001-AC-125	4001-AC-225	4001-AC-325	2000-CO-040
1.2835 - 1.4408	94505-MC-040	4505-MC-040	4001-CH-035	4001-AC-135	4001-AC-235	4001-AC-335	2000-CO-040
1.4409 - 1.5983	94505-MC-045	4505-MC-045	4001-CH-035	4001-AC-135	4001-AC-235	4001-AC-335	2000-CO-050
1.5984 - 1.7952	94505-MC-050	4505-MC-050	4001-CH-045	4001-AC-145	4001-AC-245	4001-AC-345	2000-CO-060
1.7953 - 1.9527	94505-MC-060	4505-MC-060	4001-CH-055	4001-AC-155	4001-AC-255	4001-AC-355	2000-CO-060
1.9528 - 2.1889	94505-MC-070	4505-MC-070	4001-CH-055	4001-AC-155	4001-AC-255	4001-AC-355	2000-CO-070
2.1890 - 2.3857	94505-MC-075	4505-MC-075	4001-CH-055	4001-AC-155	4001-AC-255	4001-AC-355	2000-CO-080
2.3858 - 2.5826	94505-MC-080	4505-MC-080	4001-CH-065	4001-AC-165	4001-AC-265	4001-AC-365	2000-CO-080
2.5827 - 2.7794	94505-MC-085	4505-MC-085	4001-CH-065	4001-AC-165	4001-AC-265	4001-AC-365	2000-CO-090
2.7795 - 3.1338	94505-MC-090	4505-MC-090	4001-CH-065	4001-AC-165	4001-AC-265	4001-AC-365	2000-CO-090
3.1339 - 3.5668	94505-MC-100	4505-MC-100	4001-CH-085	4001-AC-185	4001-AC-285	4001-AC-385	2000-CO-090
3.5669 - 3.9602	94505-MC-110	4505-MC-110	4001-CH-085	4001-AC-185	4001-AC-285	4001-AC-385	2000-CO-090

Arbors can be made with or without a Shank Flat.



ALVAN® Ring Arbors Extra Short Length Modular Shank

RADIAL COOLANT - THROUGH HOLES

Series 4330

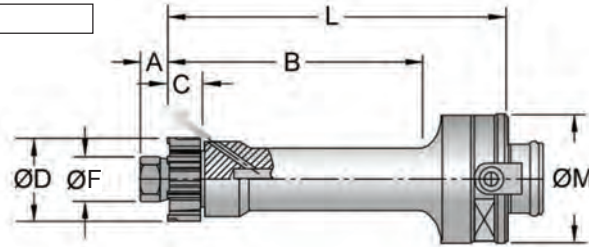

ØD (inch)	ØF (inch)	A (inch)	B (inch)	C (inch)	L (inch)	Modular Shank ØM	Number of Teeth
0.6929 - 0.8503	0.472	0.433	2.165	0.433	2.953	50	6
0.8504 - 1.0078	0.472	0.433	2.165	0.472	2.953	50	6
1.0079 - 1.2834	0.614	0.433	2.362	0.551	3.150	50	6
1.2835 - 1.5983	0.866	0.551	2.362	0.630	3.150	50	6
1.5984 - 1.7952	1.000	0.591	2.362	0.630	3.150	50	6
1.7953 - 2.3857	1.181	0.807	2.362	0.728	3.150	50	6
2.3858 - 3.1338	1.575	0.965	2.559	0.728	3.543	63	6
3.1339 - 3.9602	2.205	1.122	2.559	0.728	3.543	63	8

SPARE PARTS

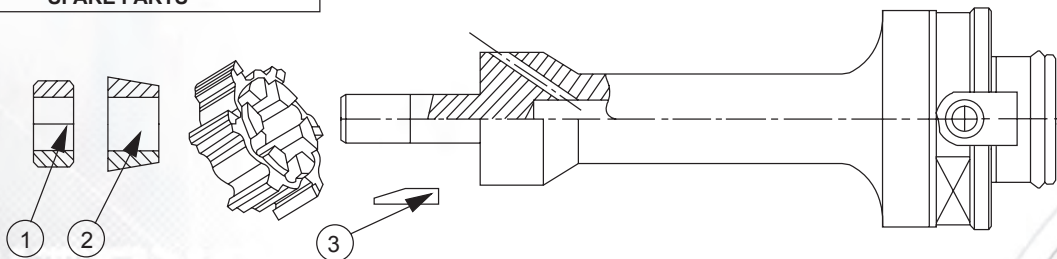

ØD (inch)	Complete Mandrel without Cutting Ring	Nut 1	Conical Ring 2	Drive Pin 3
0.6929 - 0.8503	4330-MC-010	2000-DA-010	2010-AC-010	2000-CO-010
0.8504 - 1.0078	4330-MC-020	2000-DA-010	2010-AC-010	2000-CO-020
1.0079 - 1.1653	4330-MC-030	2000-DA-020	2010-AC-020	2000-CO-030
1.2835 - 1.4408	4330-MC-040	2000-DA-060	2010-AC-030	2000-CO-040
1.5984 - 1.7952	4330-MC-050	2000-DA-090	2010-AC-040	2000-CO-060
1.7953 - 1.9527	4330-MC-060	2000-GH-880	2010-AC-050	2000-CO-060
1.9528 - 2.1889	4330-MC-070	2000-GH-880	2010-AC-050	2000-CO-070
2.3858 - 2.5826	4330-MC-080	2000-GH-900	2010-AC-060	2000-CO-080
2.7795 - 3.1338	4330-MC-090	2000-GH-900	2010-AC-060	2000-CO-090
3.1339 - 3.5668	4330-MC-100	2000-GH-920	2010-AC-070	2000-CO-090
3.5669 - 3.9602	4330-MC-110	2000-GH-920	2010-AC-070	2000-CO-090

ALVAN® Ring Arbors Extra Short Length Modular Shank



RADIAL COOLANT - BLIND HOLES

Series 4335

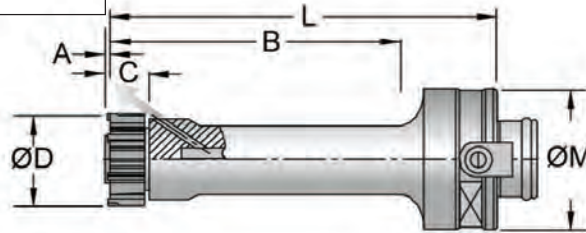

ØD (inch)	A (inch)	B (inch)	C (inch)	L (inch)	Modular Shank ØM	Number of Teeth
0.6929 - 0.8503	0.039	2.165	0.433	2.953	50	6
0.8504 - 1.0078	0.039	2.165	0.472	2.953	50	6
1.0079 - 1.2834	0.039	2.362	0.551	3.150	50	6
1.2835 - 1.5983	0.039	2.362	0.630	3.150	50	6
1.5984 - 1.7952	0.039	2.362	0.630	3.150	50	6
1.7953 - 2.3857	0.059	2.362	0.728	3.150	50	6
2.3858 - 3.1338	0.059	2.559	0.728	3.543	63	6
3.1339 - 3.9602	0.059	2.559	0.728	3.543	63	8

SPARE PARTS

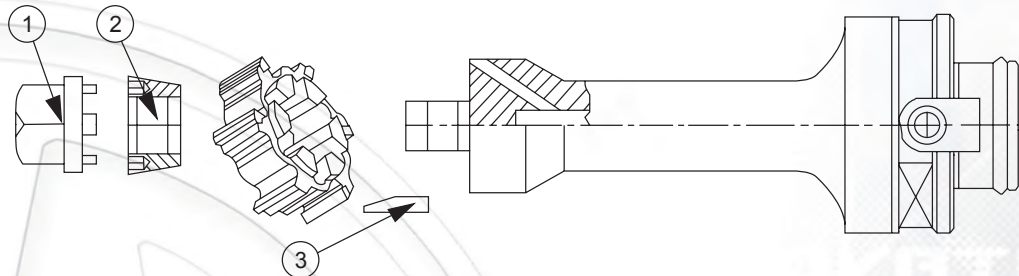

ØD (inch)	Complete Mandrel without Cutting Ring	Adjusting Key	Conical Ring	Conical Ring Second Expansion	Conical Ring Third Expansion	Drive Pin
		1	2	2	2	3
0.6929 - 0.8503	4335-MC-010	4001-CH-015	4001-AC-115	4001-AC-215	-	2000-CO-010
0.8504 - 1.0078	4335-MC-020	4001-CH-015	4001-AC-115	4001-AC-215	-	2000-CO-020
1.0079 - 1.1653	4335-MC-030	4001-CH-025	4001-AC-125	4001-AC-225	4001-AC-325	2000-CO-030
1.1654 - 1.2834	4335-MC-035	4001-CH-025	4001-AC-125	4001-AC-225	4001-AC-325	2000-CO-040
1.2835 - 1.4408	4335-MC-040	4001-CH-035	4001-AC-135	4001-AC-235	4001-AC-335	2000-CO-040
1.4409 - 1.5983	4335-MC-045	4001-CH-035	4001-AC-135	4001-AC-235	4001-AC-335	2000-CO-050
1.5984 - 1.7952	4335-MC-050	4001-CH-045	4001-AC-145	4001-AC-245	4001-AC-345	2000-CO-060
1.7953 - 1.9527	4335-MC-060	4001-CH-055	4001-AC-155	4001-AC-255	4001-AC-355	2000-CO-060
1.9528 - 2.1889	4335-MC-070	4001-CH-055	4001-AC-155	4001-AC-255	4001-AC-355	2000-CO-070
2.1890 - 2.3857	4335-MC-075	4001-CH-055	4001-AC-155	4001-AC-255	4001-AC-355	2000-CO-080
2.3858 - 2.5826	4335-MC-080	4001-CH-065	4001-AC-165	4001-AC-265	4001-AC-365	2000-CO-080
2.5827 - 2.7794	4335-MC-085	4001-CH-065	4001-AC-165	4001-AC-265	4001-AC-365	2000-CO-090
2.7795 - 3.1338	4335-MC-090	4001-CH-065	4001-AC-165	4001-AC-265	4001-AC-365	2000-CO-090
3.1339 - 3.5668	4335-MC-100	4001-CH-085	4001-AC-185	4001-AC-285	4001-AC-385	2000-CO-090
3.5669 - 3.9602	4335-MC-110	4001-CH-085	4001-AC-185	4001-AC-285	4001-AC-385	2000-CO-090



ALVAN® Ring Arbors

Short Length

Modular Shank

RADIAL COOLANT - THROUGH HOLES

Series 4350

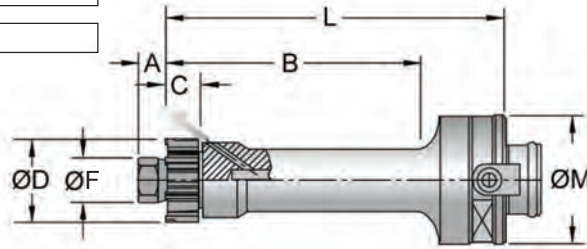

ØD (inch)	ØF (inch)	A (inch)	B (inch)	C (inch)	L (inch)	Modular Shank ØM	Number of Teeth
0.6929 - 0.8503	0.472	0.433	3.189	0.433	4.567	50	6
0.8504 - 1.0078	0.472	0.433	3.189	0.472	4.567	50	6
1.0079 - 1.2834	0.614	0.433	4.016	0.551	5.394	50	6
1.2835 - 1.5983	0.866	0.551	4.016	0.630	5.394	50	6
1.5984 - 1.7952	1.000	0.591	4.016	0.630	5.394	50	6
1.7953 - 2.3857	1.181	0.807	4.134	0.728	5.512	50	6
2.3858 - 3.1338	1.575	0.965	4.134	0.728	5.512	63	6
3.1339 - 3.9602	2.205	1.122	4.134	0.728	5.512	63	8
3.9606 - 4.3542	2.906	1.398	4.134	0.728	5.512	80	10
4.3543 - 4.5511	3.181	1.398	4.134	0.728	5.512	80	12
4.5512 - 4.9448	3.417	1.398	4.134	0.728	5.512	80	12
4.9449 - 5.4960	3.575	1.398	4.134	0.728	5.512	80	12
5.4961 - 5.7322	4.047	1.398	4.134	0.728	5.512	80	12
5.7232 - 6.1259	4.244	1.398	4.134	0.728	5.512	80	12
6.1260 - 6.5196	4.244	1.909	4.134	0.728	5.512	80	12
6.5197 - 6.9133	4.638	1.909	4.134	0.728	5.512	80	12
6.9134 - 7.3070	5.031	1.909	4.134	0.728	5.512	80	12
7.3071 - 7.7007	5.425	1.909	4.134	0.728	5.512	80	12

SPARE PARTS

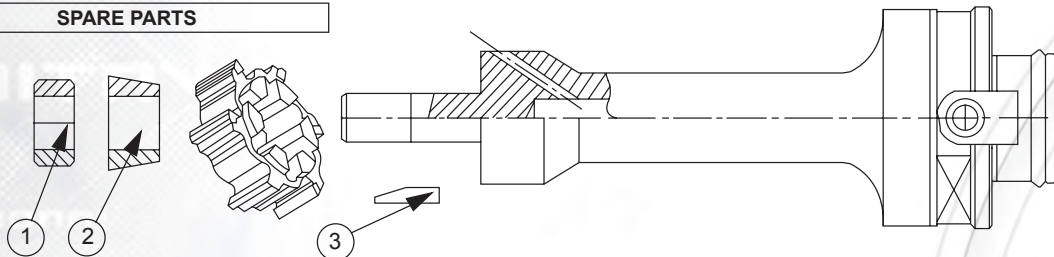

0.6929 through 4.3542					4.3543 through 7.8972				
ØD (inch)	Complete Mandrel without Cutting Ring	Nut 1	Conical Ring 2	Drive Pin 3	ØD (inch)	Complete Mandrel without Cutting Ring	Nut 1	Conical Ring 2	Drive Pin 3
0.6929 - 0.8503	4350-MC-010	2000-DA-010	2010-AC-010	2000-CO-010	4.3543 - 4.5511	4350-MC-130	2000-GH-095	2060-BU-020	2000-CO-090
0.8504 - 1.0078	4350-MC-020	2000-DA-010	2010-AC-010	2000-CO-020	4.5512 - 4.7479	4350-MC-140	2000-GH-095	2060-BU-030	2000-CO-090
1.0079 - 1.2834	4350-MC-030	2000-DA-020	2010-AC-020	2000-CO-030	4.7480 - 4.9448	4350-MC-150	2000-GH-095	2060-BU-030	2000-CO-090
1.2835 - 1.5983	4350-MC-040	2000-DA-060	2010-AC-030	2000-CO-040	4.9449 - 5.2204	4350-MC-160	2000-GH-095	2060-BU-040	2000-CO-100
1.5984 - 1.7952	4350-MC-050	2000-DA-090	2010-AC-040	2000-CO-060	5.2205 - 5.4960	4350-MC-170	2000-GH-095	2060-BU-040	2000-CO-100
1.7953 - 1.9527	4350-MC-060	2000-GH-880	2010-AC-050	2000-CO-060	5.4961 - 5.7322	4350-MC-180	2000-GH-095	2060-BU-050	2000-CO-100
1.9528 - 2.3857	4350-MC-070	2000-GH-880	2010-AC-050	2000-CO-070	5.7323 - 6.1259	4350-MC-190	2000-GH-095	2060-BU-060	2000-CO-110
2.3858 - 2.7794	4350-MC-080	2000-GH-900	2010-AC-060	2000-CO-080	6.1260 - 6.5196	4350-MC-200	2000-GH-120	2060-BU-070	2000-CO-110
2.7795 - 3.1338	4350-MC-090	2000-GH-900	2010-AC-060	2000-CO-090	6.5197 - 6.9133	4350-MC-210	2000-GH-120	2060-BU-080	2000-CO-110
3.1339 - 3.5668	4350-MC-100	2000-GH-920	2010-AC-070	2000-CO-090	6.9134 - 7.3070	4350-MC-220	2000-GH-120	2060-BU-090	2000-CO-120
3.5669 - 3.9602	4350-MC-110	2000-GH-920	2010-AC-070	2000-CO-090	7.3071 - 7.7007	4350-MC-230	2000-GH-120	2060-BU-100	2000-CO-120
3.9606 - 4.3542	4350-MC-120	2000-GH-095	2060-BU-010	2000-CO-090	7.7008 - 7.8972	4350-MC-240	2000-GH-120	2060-BU-110	2000-CO-120

ALVAN® Ring Arbors

Short Length

Modular Shank



RADIAL COOLANT - BLIND HOLES

Series 4355

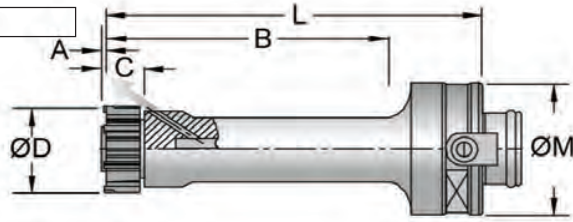

ØD (inch)	A (inch)	B (inch)	C (inch)	L (inch)	Modular Shank ØM	Number of Teeth
0.6929 - 0.8503	0.039	3.189	0.433	4.567	50	6
0.8504 - 1.0078	0.039	3.189	0.472	4.567	50	6
1.0079 - 1.2834	0.039	4.016	0.551	5.394	50	6
1.2835 - 1.5983	0.039	4.016	0.630	5.394	50	6
1.5984 - 1.7952	0.039	4.016	0.630	5.394	50	6
1.7953 - 2.3857	0.059	4.134	0.728	5.512	50	6
2.3858 - 3.1338	0.059	4.134	0.728	5.512	63	6
3.1339 - 3.9602	0.059	4.134	0.728	5.512	63	8

SPARE PARTS

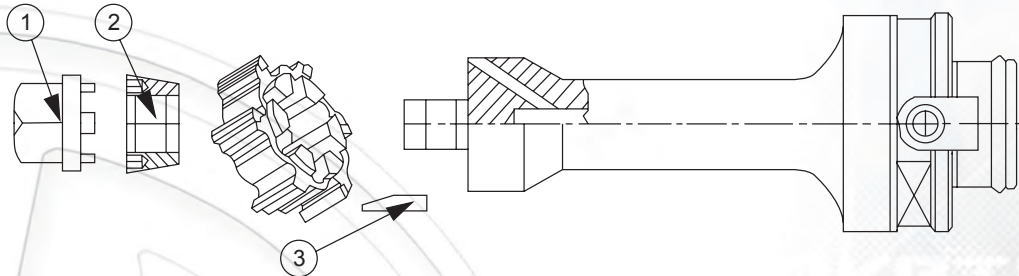

ØD (inch)	Complete Mandrel without Cutting Ring	Adjusting Key 1	Conical Ring 2	Conical Ring Second Expansion 2	Conical Ring Third Expansion 2	Drive Pin 3
0.6929 - 0.8503	4355-MC-010	4001-CH-015	4001-AC-115	4001-AC-215	-	2000-CO-010
0.8504 - 1.0078	4355-MC-020	4001-CH-015	4001-AC-115	4001-AC-215	-	2000-CO-020
1.0079 - 1.1653	4355-MC-030	4001-CH-025	4001-AC-125	4001-AC-225	4001-AC-325	2000-CO-030
1.1654 - 1.2834	4355-MC-035	4001-CH-025	4001-AC-125	4001-AC-225	4001-AC-325	2000-CO-040
1.2835 - 1.4408	4355-MC-040	4001-CH-035	4001-AC-135	4001-AC-235	4001-AC-335	2000-CO-040
1.4409 - 1.5983	4355-MC-045	4001-CH-035	4001-AC-135	4001-AC-235	4001-AC-335	2000-CO-050
1.5984 - 1.7952	4355-MC-050	4001-CH-045	4001-AC-145	4001-AC-245	4001-AC-345	2000-CO-060
1.7953 - 1.9527	4355-MC-060	4001-CH-055	4001-AC-155	4001-AC-255	4001-AC-355	2000-CO-060
1.9528 - 2.1889	4355-MC-070	4001-CH-055	4001-AC-155	4001-AC-255	4001-AC-355	2000-CO-070
2.1890 - 2.3857	4355-MC-075	4001-CH-055	4001-AC-155	4001-AC-255	4001-AC-355	2000-CO-080
2.3858 - 2.5826	4355-MC-080	4001-CH-065	4001-AC-165	4001-AC-265	4001-AC-365	2000-CO-080
2.5827 - 2.7794	4355-MC-085	4001-CH-065	4001-AC-165	4001-AC-265	4001-AC-365	2000-CO-090
2.7795 - 3.1338	4355-MC-090	4001-CH-065	4001-AC-165	4001-AC-265	4001-AC-365	2000-CO-090
3.1339 - 3.5668	4355-MC-100	4001-CH-085	4001-AC-185	4001-AC-285	4001-AC-385	2000-CO-090
3.5669 - 3.9602	4355-MC-110	4001-CH-085	4001-AC-185	4001-AC-285	4001-AC-385	2000-CO-090



ALVAN® Ring Arbors

Long Length

Modular Shank

RADIAL COOLANT - THROUGH HOLES

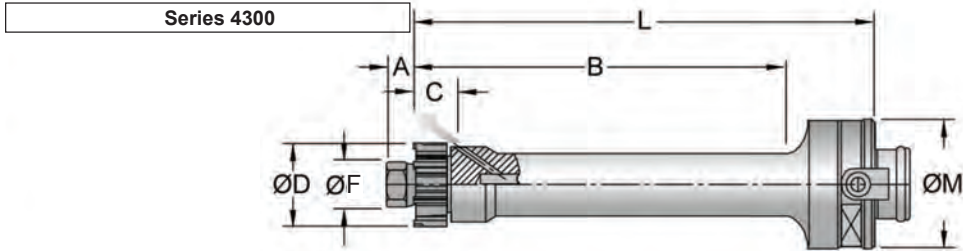

ØD (inch)	ØF (inch)	A (inch)	B (inch)	C (inch)	L (inch)	Modular Shank ØM	Number of Teeth
0.6929 - 0.8503	0.472	0.433	4.764	0.433	6.142	50	6
0.8504 - 1.0078	0.472	0.433	4.764	0.472	6.142	50	6
1.0079 - 1.2834	0.614	0.433	6.024	0.551	7.402	50	6
1.2835 - 1.5983	0.866	0.551	7.047	0.630	8.425	50	6
1.5984 - 1.7952	1.000	0.591	7.913	0.630	9.291	50	6
1.7953 - 2.3857	1.181	0.807	8.425	0.728	9.803	50	6

SPARE PARTS

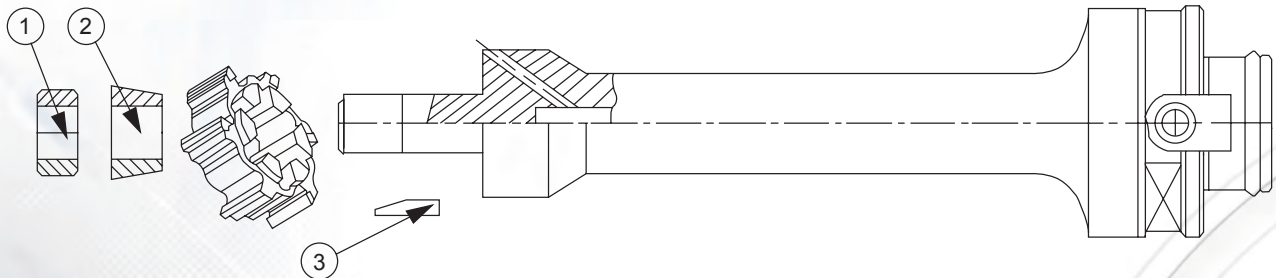

ØD (inch)	Complete Mandrel without Cutting Ring	Nut 1	Conical Ring 2	Drive Pin 3
0.6929 - 0.8503	4300-MC-010	2000-DA-010	2010-AC-010	2000-CO-010
0.8504 - 1.0078	4300-MC-020	2000-DA-010	2010-AC-010	2000-CO-020
1.0079 - 1.2834	4300-MC-030	2000-DA-020	2010-AC-020	2000-CO-030
1.2835 - 1.5983	4300-MC-040	2000-DA-060	2010-AC-030	2000-CO-040
1.5984 - 1.7952	4300-MC-050	2000-DA-090	2010-AC-040	2000-CO-060
1.7953 - 1.9527	4300-MC-060	2000-GH-880	2010-AC-050	2000-CO-060
1.9528 - 2.3857	4300-MC-070	2000-GH-880	2010-AC-050	2000-CO-070

ALVAN® Ring Arbors Long Length Modular Shank



RADIAL COOLANT - BLIND HOLES

Series 4305

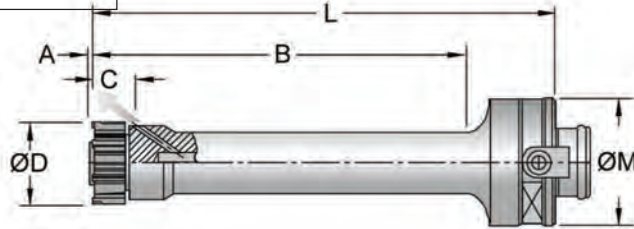

ØD (inch)	A (inch)	B (inch)	C (inch)	L (inch)	Modular Shank ØM	Number of Teeth
0.6929 - 0.8503	0.039	4.764	0.433	6.142	50	6
0.8504 - 1.0078	0.039	4.764	0.472	6.142	50	6
1.0079 - 1.2834	0.039	6.024	0.551	7.402	50	6
1.2835 - 1.5983	0.039	7.047	0.630	8.425	50	6
1.5984 - 1.7952	0.039	7.913	0.630	9.291	50	6
1.7953 - 2.3857	0.059	8.425	0.728	9.803	50	6

SPARE PARTS

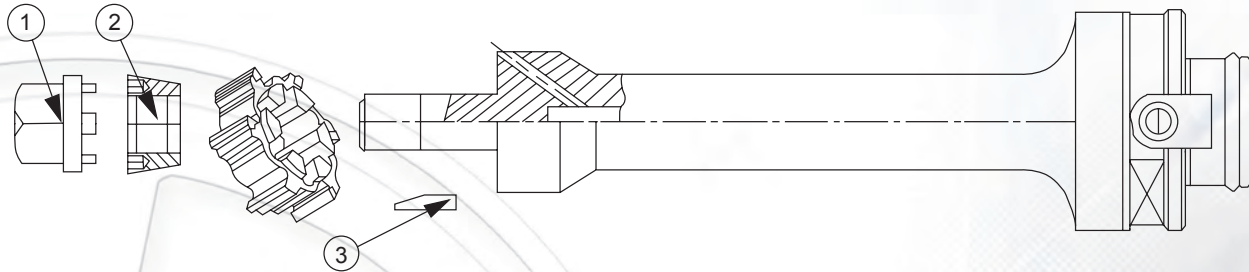

ØD (inch)	Complete Mandrel without Cutting Ring	Adjusting Key 1	Conical Ring 2	Conical Ring Second Expansion 2	Conical Ring Third Expansion 2	Drive Pin 3
0.6929 - 0.8503	4305-MC-010	4001-CH-015	4001-AC-115	4001-AC-215	-	2000-CO-010
0.8504 - 1.0078	4305-MC-020	4001-CH-015	4001-AC-115	4001-AC-215	-	2000-CO-020
1.0079 - 1.1653	4305-MC-030	4001-CH-025	4001-AC-125	4001-AC-225	4001-AC-325	2000-CO-030
1.1654 - 1.2834	4305-MC-035	4001-CH-025	4001-AC-125	4001-AC-225	4001-AC-325	2000-CO-040
1.2835 - 1.4408	4305-MC-040	4001-CH-035	4001-AC-135	4001-AC-235	4001-AC-335	2000-CO-040
1.4409 - 1.5983	4305-MC-045	4001-CH-035	4001-AC-135	4001-AC-235	4001-AC-335	2000-CO-050
1.5984 - 1.7952	4305-MC-050	4001-CH-045	4001-AC-145	4001-AC-245	4001-AC-345	2000-CO-060
1.7953 - 1.9527	4305-MC-060	4001-CH-055	4001-AC-155	4001-AC-255	4001-AC-355	2000-CO-060
1.9528 - 2.1889	4305-MC-070	4001-CH-055	4001-AC-155	4001-AC-255	4001-AC-355	2000-CO-070
2.1890 - 2.3857	4305-MC-075	4001-CH-055	4001-AC-155	4001-AC-255	4001-AC-355	2000-CO-080

ALVAN® Cutting Rings



Instructions

Diameter Measure

- The diameter of the reamers and of the cutting rings are measured with a micrometer.
- We recommend the use of a comparator style micrometer with at least a $2\mu\text{m}$ resolution to avoid micro chipping of the cutting edges.
- The reamers are marked with a dimple (see diagram below).
- The cutting edges are asymmetric with only two cutting edges that are exactly 180° . Opposed diameter measurement can only be taken across those two cutting edges.
- Measurement must be taken from the front of the cutting edges only.

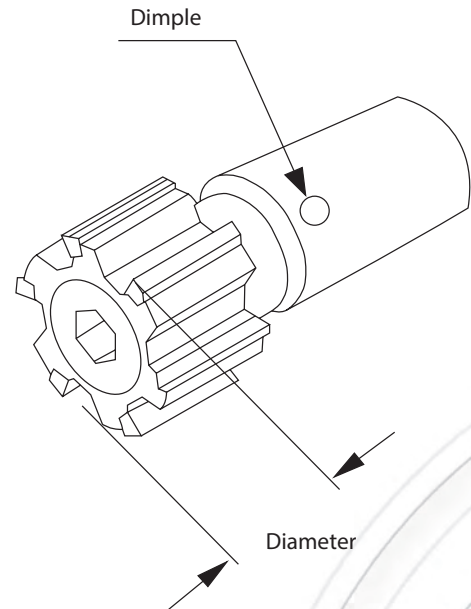
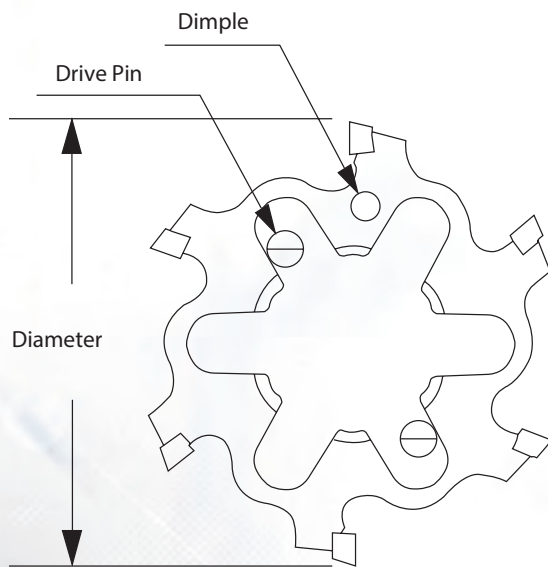

Tolerance

- All monobloc reamers are ground to the requested diameter and set in the middle of the hole tolerance, ready to use.

Assembly

- The adjustment must be made to compensate for wear to the cutting edges when the size reaches its lower tolerance. This operation can be repeated several times until the surface finish of the hole deteriorates to an unacceptable level. Then the reamer must be reground.
- The maximum expansion is about 1% of the diameter for the monobloc reamers and about 4% of the diameter for the cutting rings.

Recommended Speeds & Feeds

Inch Conventional Reaming

Uncoated Carbide



MATERIAL	MATERIAL HARDNESS BHN	REAMER DIAMETER (INCH)	STOCK ALLOWANCE ON DIAMETER (INCH)	SURFACE SPEED SFM	FEED IPR	COOLANT TYPE
Mild Steel Unalloyed	Up to 150	Up to 0.394	0.004 - 0.008	23 - 49	0.006 - 0.012	Water Soluable Cutting Oil
		0.394 - 0.866	0.006 - 0.010		0.010 - 0.020	
		0.866 - 1.575	0.008 - 0.016		0.012 - 0.031	
		1.575 - 1.969	0.012 - 0.016		0.024 - 0.039	
		1.969 - 2.756	0.014 - 0.020		0.024 - 0.047	
		2.756 - 3.937	0.016 - 0.020		0.031 - 0.059	
Low Alloyed Structural Steel	Greater than 150	Up to 0.394	0.004 - 0.008	20 - 33	0.004 - 0.012	Water Soluable Cutting Oil
		0.394 - 0.866	0.006 - 0.010		0.008 - 0.016	
		0.866 - 1.575	0.008 - 0.016		0.012 - 0.024	
		1.575 - 1.969	0.012 - 0.016		0.024 - 0.039	
		1.969 - 2.756	0.014 - 0.020		0.024 - 0.047	
		2.756 - 3.937	0.016 - 0.020		0.031 - 0.059	
Alloy Steel Stainless Steel	Up to 300	Up to 0.394	0.004 - 0.008	13 - 26	0.004 - 0.012	Water Soluable Cutting Oil
		0.394 - 0.866	0.006 - 0.010		0.008 - 0.016	
		0.866 - 1.575	0.008 - 0.016		0.012 - 0.024	
		1.575 - 1.969	0.012 - 0.016		0.024 - 0.039	
		1.969 - 2.756	0.014 - 0.020		0.024 - 0.047	
		2.756 - 3.937	0.016 - 0.020		0.031 - 0.059	
High Strength Alloy Steel Steel with Manganese	240 to 450	Up to 0.394	0.004 - 0.008	10 - 20	0.004 - 0.008	Water Soluable Cutting Oil
		0.394 - 0.866	0.006 - 0.010		0.006 - 0.016	
		0.866 - 1.575	0.008 - 0.016		0.012 - 0.020	
		1.575 - 1.969	0.012 - 0.016		0.012 - 0.028	
		1.969 - 2.756	0.014 - 0.020		0.016 - 0.031	
		2.756 - 3.937	0.016 - 0.020		0.020 - 0.039	
Stainless Steel	Up to 300	Up to 0.394	0.004 - 0.008	13 - 26	0.004 - 0.012	Water Soluable Cutting Oil
		0.394 - 0.866	0.006 - 0.010		0.008 - 0.016	
		0.866 - 1.575	0.008 - 0.016		0.012 - 0.024	
		1.575 - 1.969	0.012 - 0.016		0.024 - 0.039	
		1.969 - 2.756	0.014 - 0.020		0.024 - 0.047	
		2.756 - 3.937	0.016 - 0.020		0.031 - 0.059	
Grey Cast Iron Spheroidal Cast Iron (Pearlitic) Malleable Cast Iron	Up to 200	Up to 0.394	0.004 - 0.008	49 - 98	0.008 - 0.020	Water Soluable Cutting Oil
		0.394 - 0.866	0.006 - 0.010		0.016 - 0.024	
		0.866 - 1.575	0.008 - 0.016		0.024 - 0.047	
	Greater than 200	1.575 - 1.969	0.012 - 0.016	33 - 66	0.030 - 0.059	
		1.969 - 2.756	0.014 - 0.020		0.031 - 0.063	
		2.756 - 3.937	0.016 - 0.020		0.039 - 0.071	
Spheroidal Cast Iron (Ferritic)	Up to 200	Up to 0.394	0.004 - 0.008	26 - 39	0.006 - 0.012	Water Soluable Cutting Oil
		0.394 - 0.866	0.006 - 0.010		0.016 - 0.024	
		0.866 - 1.575	0.008 - 0.016		0.020 - 0.039	
		1.575 - 1.969	0.012 - 0.016		0.030 - 0.059	
		1.969 - 2.756	0.014 - 0.020		0.031 - 0.063	
		2.756 - 3.937	0.016 - 0.020		0.039 - 0.071	
Copper and Alloys Brass	Up to 150	Up to 0.394	0.004 - 0.008	33 - 59	0.006 - 0.016	Water Soluable
		0.394 - 0.866	0.006 - 0.010		0.008 - 0.024	
		0.866 - 1.575	0.008 - 0.016		0.010 - 0.035	
		1.575 - 1.969	0.012 - 0.016		0.016 - 0.043	
		1.969 - 2.756	0.014 - 0.020		0.020 - 0.047	
		2.756 - 3.937	0.016 - 0.020		0.024 - 0.059	
Bronze Bronze Phosphorus	Up to 180	Up to 0.394	0.004 - 0.008	33 - 66	0.006 - 0.016	Water Soluable Cutting Oil
		0.394 - 0.866	0.006 - 0.010		0.010 - 0.024	
		0.866 - 1.575	0.008 - 0.016		0.020 - 0.031	
		1.575 - 1.969	0.012 - 0.016		0.024 - 0.039	
		1.969 - 2.756	0.014 - 0.020		0.028 - 0.043	
		2.756 - 3.937	0.016 - 0.020		0.031 - 0.047	
Aluminum and Light Alloys	Up to 150	Up to 0.394	0.004 - 0.008	49 - 98	0.008 - 0.012	Water Soluable Cutting Oil
		0.394 - 0.866	0.006 - 0.010		0.012 - 0.024	
		0.866 - 1.575	0.008 - 0.016		0.016 - 0.039	
		1.575 - 1.969	0.012 - 0.016		0.030 - 0.059	
		1.969 - 2.756	0.014 - 0.020		0.031 - 0.063	
		2.756 - 3.937	0.016 - 0.020		0.035 - 0.071	
Titanium and Alloys	-	Up to 0.394	0.004 - 0.008	16 - 26	0.006 - 0.012	Water Soluable Cutting Oil
		0.394 - 0.866	0.006 - 0.010		0.008 - 0.016	
		0.866 - 1.575	0.008 - 0.016		0.012 - 0.020	
		1.575 - 1.969	0.012 - 0.016		0.016 - 0.024	
		1.969 - 2.756	0.014 - 0.020		0.024 - 0.031	
		2.756 - 3.937	0.016 - 0.020		0.031 - 0.047	
Synthetic Materials	-	Up to 0.394	0.004 - 0.008	49 - 98	0.008 - 0.020	Compressed Air Dry Water Soluable
		0.394 - 0.866	0.006 - 0.010		0.016 - 0.020	
		0.866 - 1.575	0.008 - 0.016		0.020 - 0.055	
		1.575 - 1.969	0.012 - 0.016		0.031 - 0.059	
		1.969 - 2.756	0.014 - 0.020		0.035 - 0.063	
		2.756 - 3.937	0.016 - 0.020		0.039 - 0.071	

Formulas: IPM = (RPM) (IPR) SFM = RPM • 0.262 • DIA RPM = SFM • 3.82 / DIA

The speeds and feeds listed above and on the next page are considered a general starting point for all applications. Factory technical assistance is also available for your specific application through our Application Engineering Team.



Recommended Speeds & Feeds

Inch High Speed Reaming

Coated Carbide and Cermet

MATERIAL	MATERIAL HARDNESS BHN	REAMER DIAMETER (INCH)	STOCK ALLOWANCE ON DIAMETER (INCH)	TIN-TICN-TIAlN	Cermet	Lead-in A, G	Lead-in E, N, M
				Coated Carbide		FEED IPR	FEED IPR
Mild Steel Unalloyed Low Alloyed Structural Steel	Up to 150	Up to 0.394	0.003 - 0.006	200 - 260	300 - 980	0.008 - 0.016	0.012 - 0.024
		0.394 - 0.709	0.006 - 0.010			0.016 - 0.024	0.016 - 0.039
		0.709 - 1.575	0.006 - 0.012			0.020 - 0.031	0.024 - 0.047
		1.575 - 3.150	0.008 - 0.016			0.020 - 0.039	0.031 - 0.063
		Over 3.150	0.010 - 0.020			0.031 - 0.059	0.039 - 0.087
	Greater than 150	Up to 0.394	0.003 - 0.006	130 - 230	260 - 660	0.008 - 0.016	0.012 - 0.020
		0.394 - 0.709	0.006 - 0.010			0.012 - 0.024	0.012 - 0.031
		0.709 - 1.575	0.006 - 0.012			0.016 - 0.028	0.016 - 0.039
		1.575 - 3.150	0.008 - 0.016			0.020 - 0.031	0.024 - 0.055
		Over 3.150	0.010 - 0.020			0.031 - 0.047	0.039 - 0.079
Alloy Steel Stainless Steel	Up to 300	Up to 0.394	0.003 - 0.006	100 - 160	200 - 490	0.008 - 0.016	0.012 - 0.020
		0.394 - 0.709	0.006 - 0.010			0.012 - 0.024	0.012 - 0.031
		0.709 - 1.575	0.006 - 0.012			0.016 - 0.028	0.016 - 0.039
		1.575 - 3.150	0.008 - 0.016			0.020 - 0.031	0.024 - 0.055
		Over 3.150	0.010 - 0.020			0.031 - 0.047	0.039 - 0.079
High Strength Alloy Steel Steel with Manganese	240 to 450	Up to 0.394	0.003 - 0.006	50 - 100	200 - 390	0.006 - 0.012	0.008 - 0.016
		0.394 - 0.709	0.006 - 0.010			0.008 - 0.020	0.012 - 0.024
		0.709 - 1.575	0.006 - 0.012			0.012 - 0.024	0.016 - 0.031
		1.575 - 3.150	0.008 - 0.016			0.016 - 0.031	0.020 - 0.039
		Over 3.150	0.010 - 0.020			0.024 - 0.039	0.028 - 0.055
Stainless Steel	Up to 300	Up to 0.394	0.003 - 0.006	100 - 160	200 - 490	0.008 - 0.016	0.012 - 0.020
		0.394 - 0.709	0.006 - 0.010			0.012 - 0.024	0.012 - 0.031
		0.709 - 1.575	0.006 - 0.012			0.016 - 0.028	0.016 - 0.039
		1.575 - 3.150	0.008 - 0.016			0.020 - 0.031	0.024 - 0.055
		Over 3.150	0.010 - 0.020			0.031 - 0.047	0.039 - 0.079
Grey Cast Iron Spheroidal Cast Iron (Pearlitic) Malleable Cast Iron	-	Up to 0.394	0.003 - 0.006	160 - 230	-	0.008 - 0.016	0.012 - 0.024
		0.394 - 0.709	0.006 - 0.010			0.014 - 0.024	0.020 - 0.031
		0.709 - 1.575	0.006 - 0.012			0.016 - 0.039	0.024 - 0.059
		1.575 - 3.150	0.008 - 0.016			0.024 - 0.051	0.031 - 0.063
		Over 3.150	0.010 - 0.020			0.031 - 0.067	0.039 - 0.088
Spheroidal Cast Iron (Ferritic)	Up to 200	Up to 0.394	0.003 - 0.006	100 - 160	200 - 400	0.008 - 0.016	0.012 - 0.024
		0.394 - 0.709	0.006 - 0.010			0.014 - 0.024	0.020 - 0.031
		0.709 - 1.575	0.006 - 0.012			0.016 - 0.039	0.024 - 0.059
		1.575 - 3.150	0.008 - 0.016			0.024 - 0.051	0.031 - 0.063
		Over 3.150	0.010 - 0.020			0.031 - 0.067	0.039 - 0.088
Copper and Alloys Brass	Up to 150	Up to 0.394	0.003 - 0.006	330 - 660	-	0.008 - 0.016	-
		0.394 - 0.709	0.006 - 0.010			0.016 - 0.028	-
		0.709 - 1.575	0.006 - 0.012			0.020 - 0.031	-
		1.575 - 3.150	0.008 - 0.016			0.024 - 0.039	-
		Over 3.150	0.010 - 0.020			0.031 - 0.055	-
Bronze Bronze Phosphorus	Up to 180	Up to 0.394	0.003 - 0.006	260 - 520	330 - 980	0.006 - 0.012	-
		0.394 - 0.709	0.006 - 0.010			0.008 - 0.016	-
		0.709 - 1.575	0.006 - 0.012			0.012 - 0.024	-
		1.575 - 3.150	0.008 - 0.016			0.016 - 0.031	-
		Over 3.150	0.010 - 0.020			0.024 - 0.039	-
Aluminum	Up to 150	Up to 0.394	0.003 - 0.006	330 - 660	-	0.008 - 0.016	-
		0.394 - 0.709	0.006 - 0.010			0.016 - 0.024	-
		0.709 - 1.575	0.006 - 0.012			0.020 - 0.031	-
		1.575 - 3.150	0.008 - 0.016			0.024 - 0.039	-
		Over 3.150	0.010 - 0.020			0.031 - 0.055	-
Titanium and Alloys	-	Up to 0.394	0.004 - 0.008	60 - 200	-	0.006 - 0.012	-
		0.394 - 0.709	0.006 - 0.010			0.008 - 0.016	-
		0.709 - 1.575	0.008 - 0.016			0.012 - 0.020	-
		1.575 - 3.150	0.012 - 0.016			0.016 - 0.024	-
		Over 3.150	0.012 - 0.020			0.020 - 0.028	-

Formulas: $IPM = (RPM) (IPR)$ $SFM = RPM \cdot 0.262 \cdot DIA$ $RPM = SFM \cdot 3.82 / DIA$

The speeds and feeds listed above and on the next page are considered a general starting point for all applications. Factory technical assistance is also available for your specific application through our Application Engineering Team.

Recommended Speeds & Feeds

Metric Conventional Reaming

Uncoated Carbide



Material	Material Hardness BHN	Reamer Diameter (mm)	Stock Allowance on Diameter (mm)	Surface Speed M/min	Feed mm/rev	Coolant Type	
Mild Steel Unalloyed	Up to 150	Up to 10	0,10 - 0,20	7 - 15	0,15 - 0,30	Water Soluable Cutting Oil	
		10 - 22	0,15 - 0,25		0,25 - 0,50		
		22 - 40	0,20 - 0,40		0,30 - 0,80		
		40 - 50	0,30 - 0,40		0,60 - 1,00		
		50 - 70	0,35 - 0,50		0,60 - 1,20		
	Low Alloyed Structural Steel	Greater than 150	70 - 100	0,40 - 0,50	6 - 10	0,80 - 1,50	Water Soluable Cutting Oil
			Up to 10	0,10 - 0,20		0,10 - 0,30	
			10 - 22	0,15 - 0,25		0,20 - 0,40	
			22 - 40	0,20 - 0,40		0,30 - 0,60	
			40 - 50	0,30 - 0,40		0,40 - 0,80	
Alloy Steel Stainless Steel	Up to 300	50 - 70	0,35 - 0,50	4 - 8	0,50 - 0,90	Water Soluable Cutting Oil	
		70 - 100	0,40 - 0,50		0,60 - 1,20		
		Up to 10	0,10 - 0,20		0,10 - 0,30		
		10 - 22	0,15 - 0,25		0,20 - 0,40		
		22 - 40	0,20 - 0,40		0,30 - 0,60		
		40 - 50	0,30 - 0,40		0,40 - 0,80		
High Strength Alloy Steel Steel with Manganese	240 to 450	50 - 70	0,35 - 0,50	3 - 6	0,50 - 0,90	Water Soluable Cutting Oil	
		70 - 100	0,40 - 0,50		0,60 - 1,20		
		Up to 10	0,10 - 0,20		0,10 - 0,20		
		10 - 22	0,15 - 0,25		0,15 - 0,40		
		22 - 40	0,20 - 0,40		0,30 - 0,50		
Stainless Steel	Up to 300	40 - 50	0,30 - 0,40	4 - 8	0,30 - 0,70	Water Soluable Cutting Oil	
		50 - 70	0,35 - 0,50		0,40 - 0,80		
		70 - 100	0,40 - 0,50		0,50 - 1,00		
		Up to 10	0,10 - 0,20		0,10 - 0,30		
		10 - 22	0,15 - 0,25		0,20 - 0,40		
Grey Cast Iron Spheroidal Cast Iron (Pearlitic) Malleable Cast Iron	Up to 200	22 - 40	0,20 - 0,40	15 - 30	0,30 - 0,60	Water Soluable Cutting Oil	
		40 - 50	0,30 - 0,40		0,40 - 0,60		
		50 - 70	0,35 - 0,50		0,60 - 1,20		
	Greater than 200	70 - 100	0,40 - 0,50	10 - 20	0,80 - 1,60	Water Soluable Cutting Oil	
		Up to 10	0,10 - 0,20		1,00 - 1,80		
Spheroidal Cast Iron (Ferritic)	Up to 200	10 - 22	0,15 - 0,25	8 - 12	0,20 - 0,50	Water Soluable Cutting Oil	
		22 - 40	0,20 - 0,40		0,40 - 0,60		
		40 - 50	0,30 - 0,40		0,50 - 1,00		
		50 - 70	0,35 - 0,50		0,75 - 1,50		
		70 - 100	0,40 - 0,50		0,80 - 1,60		
Copper and Alloys Brass	Up to 150	Up to 10	0,10 - 0,20	10 - 18	0,15 - 0,30	Water Soluable	
		10 - 22	0,15 - 0,25		0,20 - 0,60		
		22 - 40	0,20 - 0,40		0,25 - 0,90		
		40 - 50	0,30 - 0,40		0,40 - 1,10		
		50 - 70	0,35 - 0,50		0,50 - 1,20		
Bronze Bronze Phosphorus	Up to 180	70 - 100	0,40 - 0,50	10 - 20	0,60 - 1,50	Water Soluable Cutting Oil	
		Up to 10	0,10 - 0,20		0,15 - 0,40		
		10 - 22	0,15 - 0,25		0,25 - 0,60		
		22 - 40	0,20 - 0,40		0,50 - 0,80		
		40 - 50	0,30 - 0,40		0,60 - 1,00		
Aluminum and Light Alloys	Up to 150	50 - 70	0,35 - 0,50	15 - 30	0,70 - 1,10	Water Soluable Cutting Oil	
		70 - 100	0,40 - 0,50		0,80 - 1,20		
		Up to 10	0,10 - 0,20		0,20 - 0,40		
		10 - 22	0,15 - 0,25		0,30 - 0,60		
		22 - 40	0,20 - 0,40		0,40 - 1,00		
Titanium and Alloys	-	40 - 50	0,30 - 0,40	5 - 8	0,75 - 1,50	Water Soluable Cutting Oil	
		50 - 70	0,35 - 0,50		0,80 - 1,60		
		70 - 100	0,40 - 0,50		0,90 - 1,80		
		Up to 10	0,10 - 0,20		0,15 - 0,30		
		10 - 22	0,15 - 0,25		0,20 - 0,40		
Synthetic Materials	-	22 - 40	0,20 - 0,40	15 - 30	0,30 - 0,50	Compressed Air Dry Water Soluable	
		40 - 50	0,30 - 0,40		0,40 - 0,60		
		50 - 70	0,35 - 0,50		0,60 - 0,80		
		70 - 100	0,40 - 0,50		0,80 - 1,20		
		Up to 10	0,10 - 0,20		0,20 - 0,50		

Formulas: $IPM = (RPM) (IPR)$ $SFM = RPM \cdot 0.262 \cdot DIA$ $RPM = SFM \cdot 3.82 / DIA$
 The speeds and feeds listed above and on the next page are considered a general starting point for all applications. Factory technical assistance is also available for your specific application through our Application Engineering Team.



Recommended Speeds & Feeds

Metric High Speed Reaming

Coated Carbide and Cermet

Material	Material Hardness BHN	Reamer Diameter (mm)	Stock Allowance on Diameter (mm)	TiN-TiCN-TiAlN Coated Carbide	Cermet	Lead-in A, G	Lead-in E, N, M	
				Surface Speed M/min	Surface Speed M/min	Feed mm/rev	Feed mm/rev	
Mild Steel Unalloyed Low Alloyed Structural Steel	Up to 150	Up to 10	0,08 - 0,15	60 - 80	90 - 300	0,20 - 0,40	0,30 - 0,60	
		10 - 18	0,15 - 0,25			0,40 - 0,60	0,40 - 1,00	
		18 - 40	0,15 - 0,30			0,50 - 0,80	0,60 - 1,20	
		40 - 80	0,20 - 0,40			0,50 - 1,00	0,80 - 1,60	
	Greater than 150	Over 80	0,25 - 0,50	40 - 70	80 - 200	0,80 - 1,50	1,00 - 2,20	
		Up to 10	0,08 - 0,15			0,20 - 0,40	0,30 - 0,50	
		10 - 18	0,15 - 0,25			0,30 - 0,60	0,30 - 0,80	
		18 - 40	0,15 - 0,30			0,40 - 0,70	0,40 - 1,00	
Alloy Steel Stainless Steel	Up to 300	Up to 10	0,08 - 0,15	30 - 50	60 - 150	0,20 - 0,40	0,30 - 0,50	
		10 - 18	0,15 - 0,25			0,30 - 0,60	0,30 - 0,80	
		18 - 40	0,15 - 0,30			0,40 - 0,70	0,40 - 1,00	
		40 - 80	0,20 - 0,40			0,50 - 0,80	0,60 - 1,40	
	240 to 450	Over 80	0,25 - 0,50	15 - 30	60 - 120	0,80 - 1,20	1,00 - 2,00	
		Up to 10	0,08 - 0,15			0,15 - 0,30	0,20 - 0,40	
		10 - 18	0,15 - 0,25			0,20 - 0,50	0,30 - 0,60	
		18 - 40	0,15 - 0,30			0,30 - 0,60	0,40 - 0,80	
High Strength Alloy Steel Steel with Manganese	Up to 300	40 - 80	0,20 - 0,40	30 - 50	60 - 150	0,40 - 0,80	0,50 - 1,00	
		Over 80	0,25 - 0,50			0,80 - 1,20	1,00 - 2,00	
		Up to 10	0,08 - 0,15			0,20 - 0,40	0,30 - 0,50	
		10 - 18	0,15 - 0,25			0,30 - 0,60	0,40 - 1,00	
	240 to 450	18 - 40	0,15 - 0,30	15 - 30	60 - 120	0,40 - 0,70	0,40 - 1,00	
		40 - 80	0,20 - 0,40			0,50 - 0,80	0,60 - 1,40	
		Over 80	0,25 - 0,50			0,60 - 1,00	0,70 - 1,40	
		Up to 10	0,08 - 0,15			0,20 - 0,40	0,30 - 0,60	
Alloy Steel Stainless Steel	Up to 300	10 - 18	0,15 - 0,25	30 - 50	60 - 150	0,30 - 0,60	0,30 - 0,80	
		18 - 40	0,15 - 0,30			0,40 - 0,70	0,40 - 1,00	
		40 - 80	0,20 - 0,40			0,50 - 0,80	0,60 - 1,40	
		Over 80	0,25 - 0,50			0,80 - 1,20	1,00 - 2,00	
	Grey Cast Iron Spheroidal Cast Iron (Pearlitic) Malleable Cast Iron	-	Up to 10	0,08 - 0,15	50 - 70	-	0,20 - 0,40	0,30 - 0,60
			10 - 18	0,15 - 0,25			0,35 - 0,60	0,50 - 0,80
			18 - 40	0,15 - 0,30			0,40 - 1,00	0,60 - 1,50
			40 - 80	0,20 - 0,40			0,60 - 1,30	0,80 - 1,60
Spheroidal Cast Iron (Ferritic)	Up to 200	Over 80	0,25 - 0,50	30 - 50	60 - 120	0,80 - 1,70	1,00 - 2,25	
		Up to 10	0,08 - 0,15			0,20 - 0,40	0,30 - 0,60	
		10 - 18	0,15 - 0,25			0,35 - 0,60	0,50 - 0,80	
		18 - 40	0,15 - 0,30			0,40 - 1,00	0,60 - 1,50	
	Copper and Alloys Brass	Up to 150	40 - 80	0,20 - 0,40	100 - 200	-	0,60 - 1,00	-
			Over 80	0,25 - 0,50			0,80 - 1,40	-
			Up to 10	0,08 - 0,15			0,15 - 0,30	-
			10 - 18	0,15 - 0,25			0,20 - 0,40	-
Bronze Bronze Phosphorus	Up to 180	18 - 40	0,15 - 0,30	80 - 160	100 - 300	0,30 - 0,60	-	
		40 - 80	0,20 - 0,40			0,40 - 0,80	-	
		Over 80	0,25 - 0,50			0,60 - 1,00	-	
		Up to 10	0,08 - 0,15			0,20 - 0,40	-	
Aluminum	Up to 150	10 - 18	0,15 - 0,25	100 - 200	-	0,40 - 0,70	-	
		18 - 40	0,15 - 0,30			0,50 - 0,80	-	
		40 - 80	0,20 - 0,40			0,60 - 1,00	-	
		Over 80	0,25 - 0,50			0,80 - 1,40	-	
Titanium and Alloys	-	Up to 10	0,10 - 0,20	20 - 60	-	0,15 - 0,30	-	
		10 - 18	0,15 - 0,25			0,20 - 0,40	-	
		18 - 40	0,20 - 0,40			0,30 - 0,50	-	
		40 - 80	0,30 - 0,40			0,40 - 0,60	-	
Titanium and Alloys	-	Over 80	0,30 - 0,50	20 - 60	-	0,50 - 0,70	-	

Formulas: $IPM = (RPM) (IPR)$ $SFM = RPM \cdot 0.262 \cdot DIA$ $RPM = SFM \cdot 3.82 / DIA$

The speeds and feeds listed above and on the next page are considered a general starting point for all applications. Factory technical assistance is also available for your specific application through our Application Engineering Team.

ALVAN® Accessories





ALVAN® Modular Shanks DIN 69871/1B & A

with lateral clamping and radial adjustment

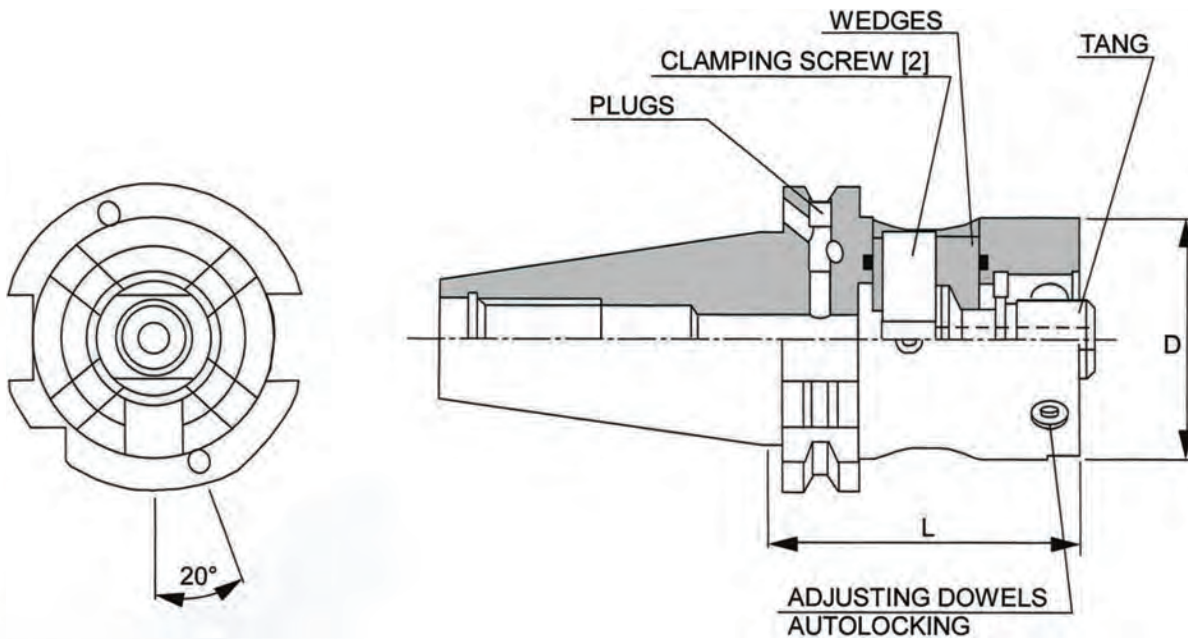

Item Number	ISO Taper	Modular Shank D	L (inch)	Retention Knob Thread Size
02B.40.50L.65	40	50	2.559	M16 x 2
02B.40.63L.85	40	63	3.346	M16 x 2
02B.45.50L.70	45	50	2.756	M20 x 2.5
02B.45.63L.70	45	63	2.756	M20 x 2.5
02B.50.50L.70	50	50	2.756	M24 x 3
02B.50.63L.70	50	63	2.756	M24 x 3
**02B.50.80L.70	50	80	2.756	M24 x 3

**Could cause interference with tool changer mechanism

NOTES: Shanks can be converted into DIN 69871/1A coolant by screwing the two plugs clockwise to the end of their stroke.

Light torque exerted on the clamping screw transmits high axial forces, which provides stiffness and extreme accuracy to the assembly.

Tang must be fitted to all ring arbors and adapters prior to assembly.

Maximum radial adjustment is ± 0.008 inch (0,20 mm) on diameter.

ALVAN® Modular Shanks JMTBA MAS-403 BT B & BT

with lateral clamping and radial adjustment

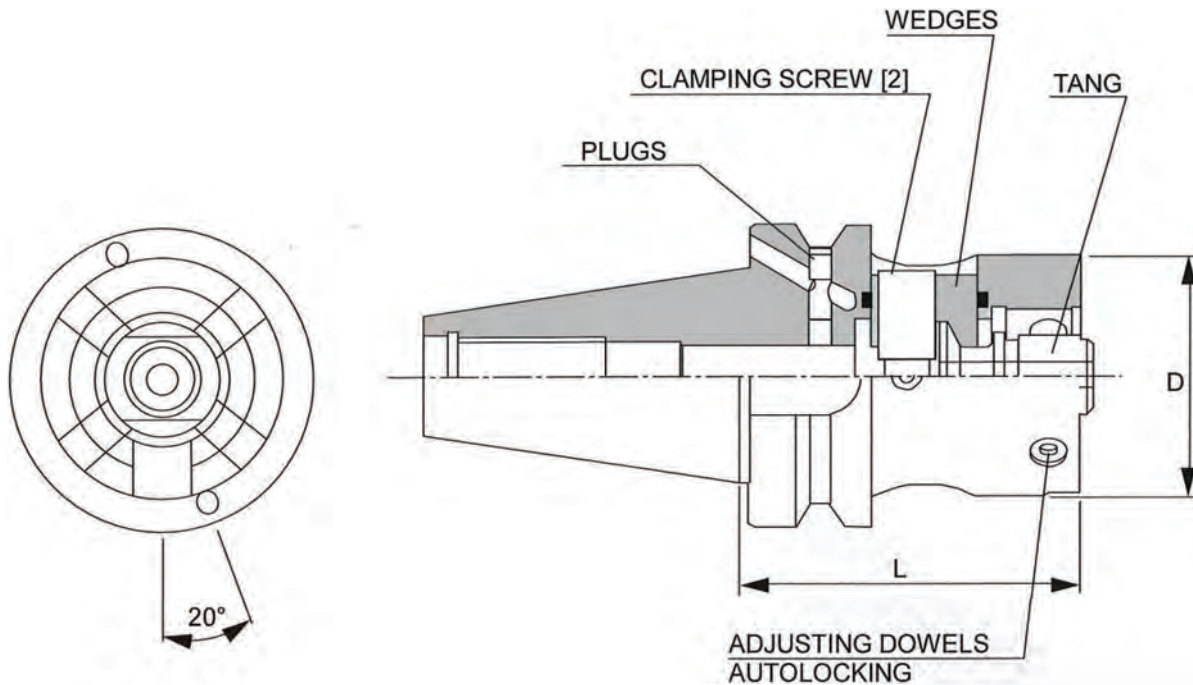

Item Number	ISO Taper	Modular Shank D	L (inch)	Retention Knob Thread Size
BTB.40.50L.70	40	50	2.756	M16 x 2
BTB.40.63L.80	40	63	3.150	M16 x 2
BTB.50.50L.90	50	50	3.543	M24 x 3
BTB.50.63L.90	50	63	3.543	M24 x 3
BTB.50.80L.90	50	80	3.543	M24 x 3

- NOTES:**
- Shanks can be converted into MAS-403 BT coolant by screwing the two plugs clockwise to the end of their stroke.
 - Light torque exerted on the clamping screw transmits high axial forces, which provides stiffness and extreme accuracy to the assembly.
 - Tang must be fitted to all ring arbors and adapters prior to assembly.
 - Maximum radial adjustment is ± 0.008 inch (0,20 mm) on diameter.



ALVAN® Modular System HSK-A DIN 69893/1 Shanks

with lateral clamping and radial adjustment

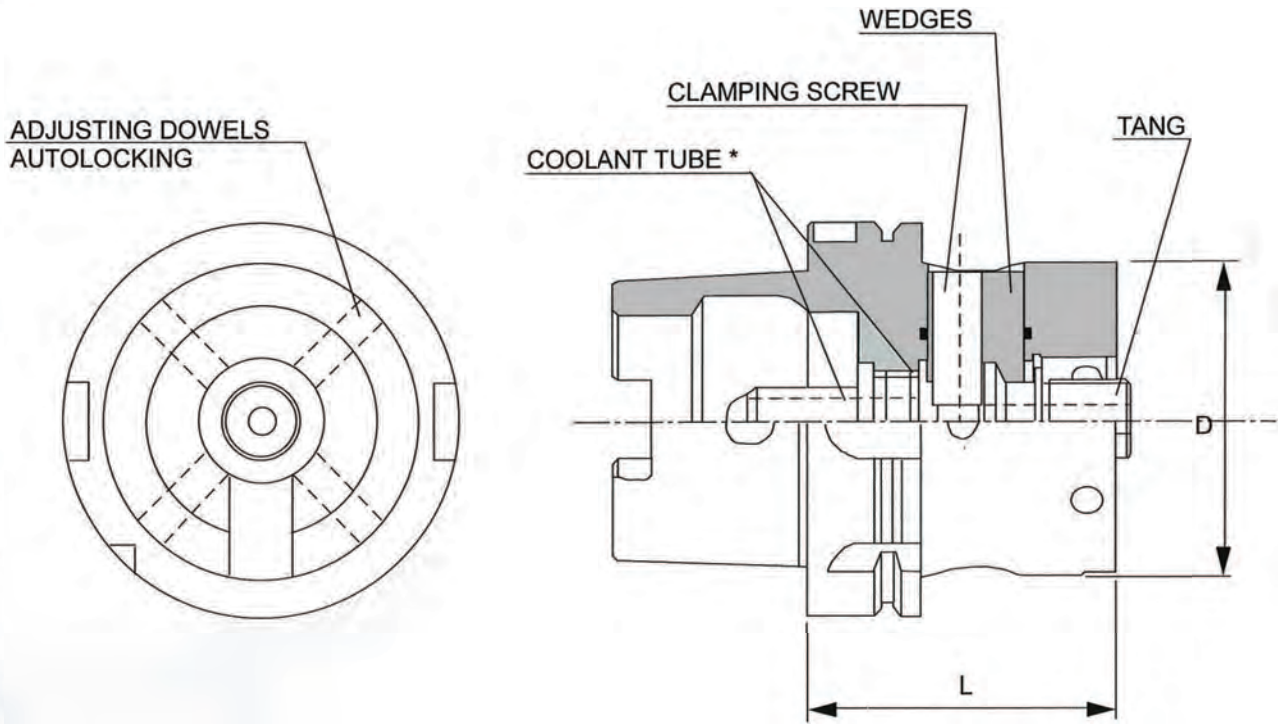

Item Number	ISO Taper	Modular Shank D	L (inch)	Accessories
				Coolant Tube*
HSKA.63.50L.70	63	50	2.756	ATT23728
HSKA.63.63L.75	63	63	2.953	ATT23728
HSKA.100.50L.80	100	50	3.150	ATT23656
HSKA.100.63L.80	100	63	3.150	ATT23656
HSKA.100.80L.80	100	80	3.150	ATT23656

NOTES: Light torque exerted on the clamping screw transmits high axial forces, which provides stiffness and extreme accuracy to the assembly.

Tang must be fitted to all ring arbors and adapters prior to assembly.

Maximum radial adjustment is ± 0.008 inch (0,20 mm) on diameter.

* Coolant tubes supplied separately

ALVAN® Modular System

Straight Shanks

with lateral clamping and radial adjustment

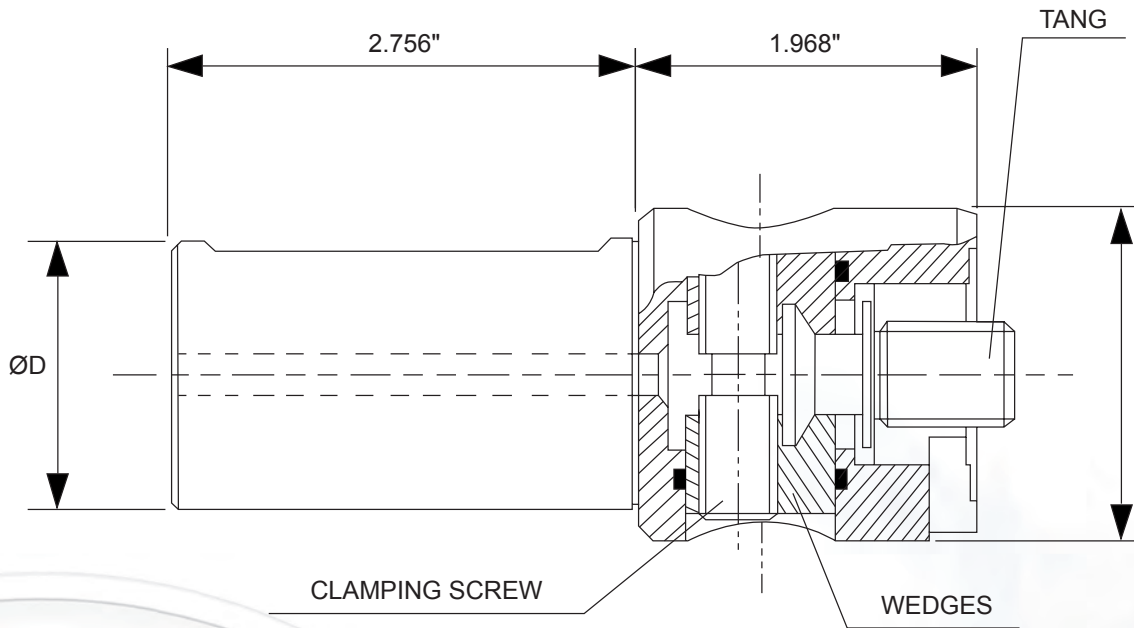

Item Number	D (mm)
CIL.25.50.50	25
CIL.32.50.50	32
CIL.40.50.50	40

- NOTES:
- Light torque exerted on the clamping screw transmits high axial forces, which provides stiffness and extreme accuracy to the assembly.
 - Tang must be fitted to all ring arbors and adapters prior to assembly.
 - Maximum radial adjustment is ± 0.008 inch (0,20 mm) on diameter.



ALVAN® Modular System Collet Chuck Adapters

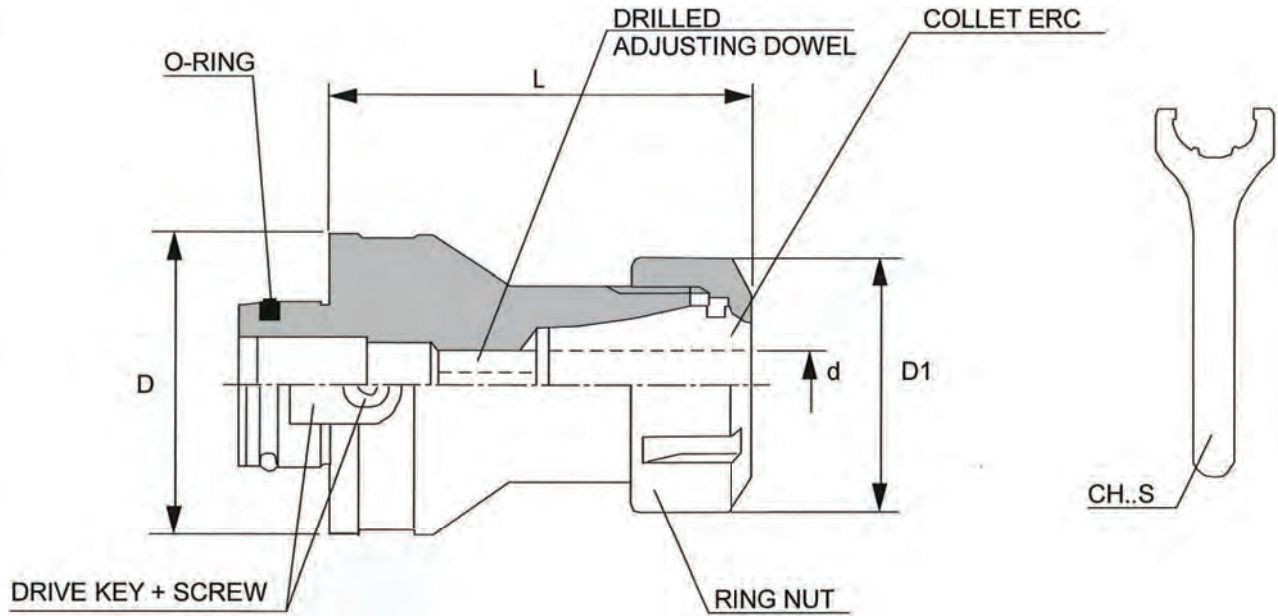

Item Number	Modular Shank D	Collet Reducer	d (inch)	D1 (inch)	L (inch)	Accessories
						Wrench*
30.50R.25.70	50	ERC25	0.0197 - 0.6299	1.654	2.756	CH25S
30.50R.32.70	50	ERC32	0.0394 - 0.7874	1.969	2.756	CH32S
30.63R.32.90	63	ERC32	0.0394 - 0.7874	1.969	3.543	CH32S
30.63R.40.90	63	ERC40	0.0787 - 1.1811	2.480	3.543	CH40S
30.80R.32.90	80	ERC32	0.0394 - 0.7874	1.969	3.543	CH32S
30.80R.40.90	80	ERC40	0.0787 - 1.1811	2.480	3.543	CH40S

NOTES: Tang must be fitted to all ring arbors and adapters prior to assembly.

* Wrench supplied separately. Collet Reducer not included.

ALVAN® Modular System

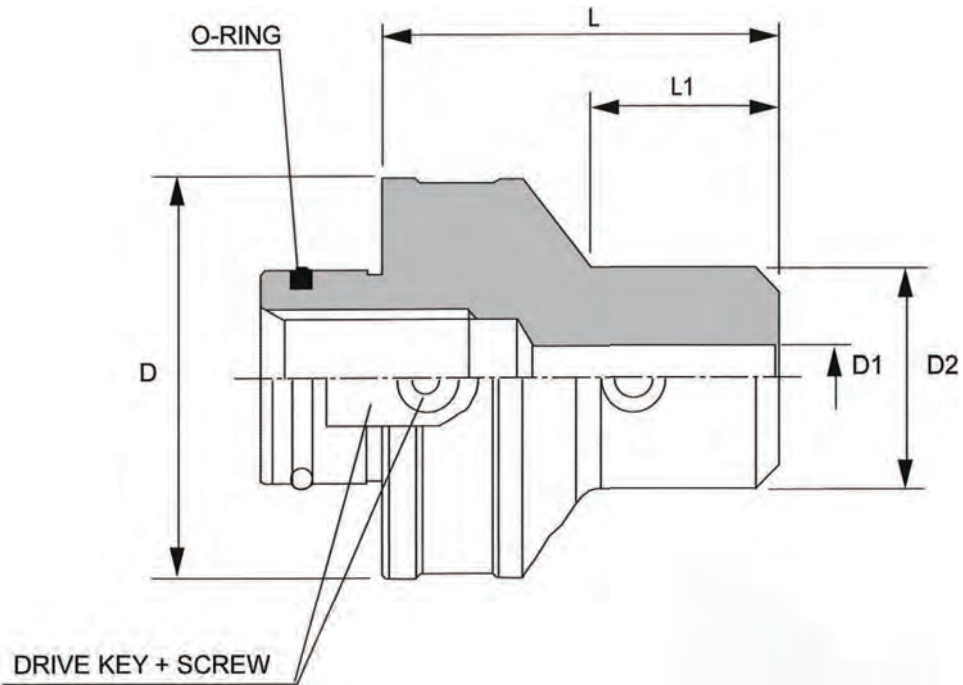

Item Number	Modular Shank D	D1 (inch)	D2 (inch)	L (inch)	L1 (inch)
35.50R.06.50	50	0.2362	0.984	1.969	0.886
35.50R.08.50	50	0.3150	1.102	1.969	0.965
35.50R.10.50	50	0.3937	1.378	1.969	1.043
35.50R.12.60	50	0.4724	1.654	2.362	1.516
35.50R.14.60	50	0.5512	1.732	2.362	1.654
35.50R.16.60	50	0.6299	1.890	2.362	1.575
35.50R.18.60	50	0.7087	1.969	2.362	-
35.50R.20.60	50	0.7874	2.047	2.362	1.614
35.63R.08.60	50	0.3150	1.102	2.362	1.102
35.63R.10.70	63	0.3937	1.378	2.756	1.575
35.63R.12.70	63	0.4724	1.654	2.756	1.654
35.63R.14.60	63	0.5512	1.732	2.756	1.260
35.63R.16.70	63	0.6299	1.890	2.756	1.732
35.63R.18.70	63	0.7087	1.969	2.756	1.575
35.63R.20.70	63	0.7874	2.047	2.756	1.772
40.50R.06.50	50	0.9843	2.559	3.150	2.402
40.50R.08.50	50	1.2598	2.835	3.150	2.559
40.63R.10.50	63	0.9843	2.559	3.150	2.283
40.63R.12.60	63	1.2598	2.835	3.150	-
40.80R.14.60	80	0.9843	2.559	3.150	1.988
40.80R.16.60	80	1.2598	2.835	3.150	2.126

NOTE: Tang must be fitted to all ring arbors and adapters prior to assembly.



ALVAN[®] Reamers

Troubleshooting Guide

Problem	Possible Cause	Possible Solution
Oversize hole	<ul style="list-style-type: none"> a.) The reamer is running eccentric to the center of the machine spindle b.) Excessive misalignment causing reamer to cut on back taper c.) Material build up on cutting edges d.) The reamer diameter is too large 	<ul style="list-style-type: none"> a.) Use the modular system with radial adjustment b.) Rectify misalignment c.) Replace the coolant or change the cutting speed d.) Use smaller reamer or regrind existing one
Undersize hole	<ul style="list-style-type: none"> a.) The reamer diameter is too small b.) The reamer diameter is worn c.) The coolant is not suitable d.) Stock allowance too small e.) The cutting speed is too low 	<ul style="list-style-type: none"> a.) Use larger reamer b.) Expand, regrind or replace the reamer c.) Replace the coolant d.) Increase the stock allowance e.) Increase the cutting speed
Tapered hole	<ul style="list-style-type: none"> a.) Excessive misalignment 	<ul style="list-style-type: none"> a.) Correct misalignment
Burr at the entry of the hole	<ul style="list-style-type: none"> a.) Excessive misalignment 	<ul style="list-style-type: none"> a.) Correct misalignment
The hole is not straight	<ul style="list-style-type: none"> a.) Concentricity and alignment error between the workpiece and the tool b.) Asymmetrical cutting or angled surfaces 	<ul style="list-style-type: none"> a.) Correct misalignment and use the modular system with radial adjustment b.) Create a chamfer on the lead-in
Poor hole finish	<ul style="list-style-type: none"> a.) One cutting edge is chipped b.) The lead-in is irregular c.) Back taper on the cutting edges too great d.) Excessive misalignment e.) Cutting data not correct f.) Poor chip evacuation 	<ul style="list-style-type: none"> a.) Regrind the reamer b.) Regrind the reamer c.) Regrind the reamer d.) Correct misalignment or use the modular system e.) Verify cutting data f.) Verify coolant volume and pressure or use through tool coolant
The reamer creates excessive torque loading	<ul style="list-style-type: none"> a.) Back taper on the cutting edges too small b.) The radially ground land is too wide c.) The coolant is not suitable 	<ul style="list-style-type: none"> a.) Regrind the reamer b.) Regrind the reamer c.) Replace the coolant

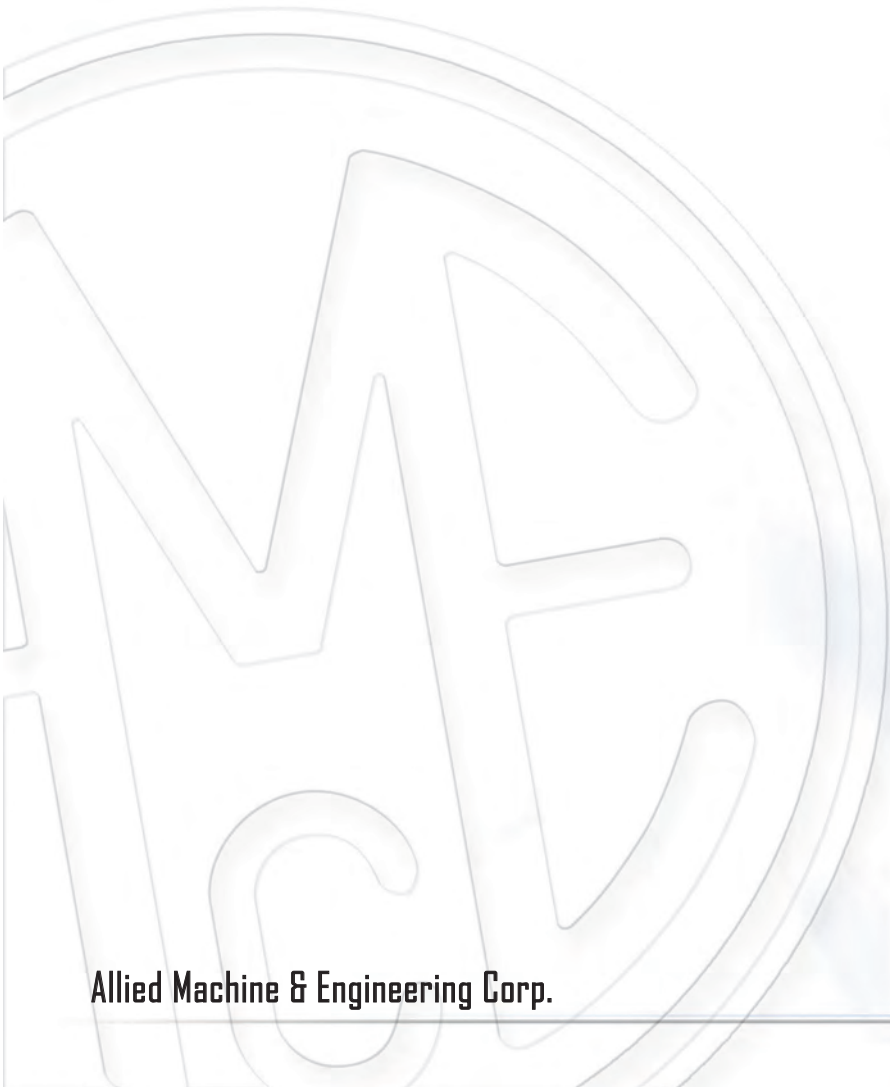



Notes

NOITANE

STANDONN

Warranty

Allied Machine & Engineering Corp. warrants to original equipment manufacturers, distributors, industrial and commercial users of its products, that each new product manufactured or supplied by Allied shall be free from defects in material and workmanship.

Allied's obligation under this warranty is limited to furnishing without additional charge a replacement or at its option, repairing or issuing credit for any product which shall within one year from the date of sale be returned freight prepaid to the plant designated by an Allied representative and which upon inspection is determined by Allied to be defective in materials or workmanship.

Complete information as to operating conditions, machine setup, and application of cutting fluid should accompany any product returned for inspection. The provisions of this warranty shall not apply to any Allied product which has been subjected to misuse, improper operating conditions, machine setup, application of cutting fluid or which has been repaired or altered if such repair or alteration in the judgement of Allied would adversely affect performance of the product.

THIS WARRANTY IS IN LIEU OF ALL OTHER WARRANTIES, EXPRESS OR IMPLIED, INCLUDING ANY IMPLIED WARRANTY OF MERCHANTABILITY OR FITNESS FOR A PARTICULAR PURPOSE. Allied shall have no liability or responsibility on any claim of any kind, whether in contract, tort or otherwise, for any loss or damage arising out of, connected with, or resulting from the manufacture, sale, delivery or use of any product sold hereunder, in excess the cost of replacement or repair as provided herein. IN NO EVENT SHALL ALLIED MACHINE & ENGINEERING CORP. BE LIABLE FOR ANY SPECIAL INCIDENTAL OR CONSEQUENTIAL DAMAGES. Allied makes no other warranty, express or implied, except as set forth above, and Allied neither assumes nor authorizes any other person or entity to assume for it any other obligation or liability in connection with any of its products.

ALL PRICES, DELIVERIES, DESIGNS, AND MATERIALS ARE SUBJECT TO CHANGE WITHOUT NOTICE.



Allied Machine & Engineering Corp.

120 Deeds Drive, Dover, Ohio 44622

Telephone: (330) 343-4283

Toll Free USA & Canada: (800) 321-5537

Fax: (330) 602-3400

Toll Free USA & Canada: (800) 223-5140

International Country Code: 01

Website Address: www.alliedmachine.com

Email Address: info@alliedmachine.com

Regional Distribution Warehouse Locations:

USA

Allied Machine & Engineering Corp.
120 Deeds Drive • PO Box 36 • Dover, Ohio 44622-0036

Telephone: (330) 343-4283
Toll Free USA & Canada: (800) 321-5537
Fax: (330) 602-3400
Toll Free USA & Canada: (800) 223-5140
Engineering Fax: (330) 364-7666

Europe

Allied Maxcut Engineering Co. Ltd.
93 Vantage Point, Pensnett Estate,
Kingswinford, West Midlands
DY6 7FR ENGLAND

Telephone: 011-44-1384-400900
Fax: 011-44-1384-400105

Other Product Literature:

Allied Drilling Products

Allied Drilling Products are designed and manufactured by Allied Machine & Engineering Corp. The combination of premium materials, along with unique geometry and coatings allows for the finest drilling systems in the metal cutting industry, resulting in the lowest cost per hole.



Literature Order Number: ADP

Structural Steel T-A® Drilling System

HIGH PERFORMANCE HOLDERS AND INSERTS



Designed specifically for use on structural steel materials, this patent-pending system delivers Outstanding Performance and Durability. TiAlN insert coating allows for increased tool life and better heat resistance while providing better hole tolerances. Tool holders can be used with standard T-A® Drill Inserts.

Literature Order Number: SS

AccuThread 856®

THREAD MILLING PRODUCTS



AccuThread 856® specific Thread Mills conform with J1926 and SAE AS5202. AccuThread 856® has a thicker core and a helical flute which offers increased strength and rigidity when cutting forces are applied. AccuThread 856® provides superior thread forms compared to other competitive thread mills and taps.

Literature Order Number: AT856

i-Form

CUSTOM INDEXABLE DRILL/FORM TOOL SYSTEM



With i-Form, you can design complex forms for any style hole with increased productivity in mind. The i-Form design (blade and form inserts) provides custom engineered forms that allow for complex design, replaceable cutting edges, and improved consistency while outperforming brazed and solid carbide tools.

Literature Order Number: IFFL

High Performance and Universal Style

DRILLS, HOLDERS, AND ACCESSORIES



This catalog lists the widest variety of Spade Drills and Holders in our industry. Our TiN, TiAlN, and TiCN coated High Performance Spade Drills (3/16" to 5") offer a 100% to 500% increase in productivity and an extended tool life of 3 to 20 times over uncoated tools.

Literature Order Number: HPU

BT-A

REPLACEABLE TIP SINGLE TUBE BTA TOOL & ACCESSORIES



Allied's BT-A tool offers a bearing area for improved straightness, as well as more balanced cutting forces. This tool also provides significantly increased penetration rates over brazed heads and traditional gun drills. The BT-A's patent-pending design allows for replaceable cutting edges, eliminating the need for re-sharpening. This tool is compatible with standard BTA-STS Systems.

Literature Order Number: BTAFL



Allied Machine & Engineering Corp.



**Allied
Machine &
Engineering Corp.**

120 Deeds Drive
Dover, OH 44622-0036

Telephone: (330) 343-4283
Toll Free USA & Canada: (800) 321-5537
Fax: (330) 602-3400
Toll Free USA & Canada: (800) 223-5140
International: Country Code 01
Website Address: www.alliedmachine.com
Email Address: info@alliedmachine.com