

automotive
SOLUTIONS

www.alliedmachine.com

BURN SOME
RUBBER

*high precision tooling solutions
for high performance parts*



Improve chip evacuation



Increase throughput



Discover unique solutions

AHB
TOOLING & MACHINERY
COMPLETE METALWORKING SOLUTIONS
(800) 991-4225 www.ahbinc.com
ISO Certified customerservice@ahbinc.com

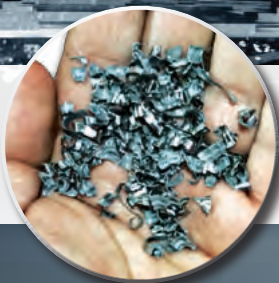

T-A[®] Stealth Drill

Chip problems in deep holes? Not anymore.





automotive **SOLUTIONS**

CONTENTS

ENGINE

Cylinder Blocks	2 - 3
Camshaft	4
Crankshaft	5
Connecting Rods & Rocker Arms	6

DRIVELINE

Axles & Weldments	7
Yokes	8 - 9

TRANSMISSION

Transmission Shafts	10 - 11
Flywheels	12
Hydraulic Pump Housings	13
Transmission Housings	14

WHEELS / BRAKING SYSTEM

Wheel Rims & Hubs	15
Brake Calipers	16
Brake Rotors	17
Brake Cylinders	18

ORDERING

The solutions listed in this guide represent general standard products and/or special product designs. To order items specific to your application, please contact your local Allied Field Sales Engineer or a member of Allied's Application Engineering Team.

Application Engineering Department
1.330.343.4283 ext.7611
appeng@alliedmachine.com



Holemaking Solutions for Today's Manufacturing



CYLINDER BLOCKS

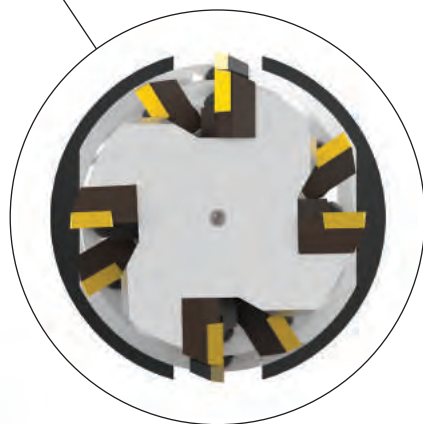

WOHLHAUPTER® FINISH BORING TOOLS LAY DOWN CARTRIDGE

- ▶ Increase the precision of your roughing tool while protecting your investment.
- ▶ If the tool is ever damaged, simply replace a cartridge and resume making chips.

BTA (STS) DEEP HOLE MACHINING BT-A DRILL

- ▶ Double effective cutting allows up to 2x penetration rates over conventional BTA heads.
- ▶ Utilizes the standard BTA-STS tube connection.
- ▶ Improves performance in cross holes.
- ▶ The versatility of available T-A geometries and substrates allows for increased penetration rates and excellent chip control in any application.

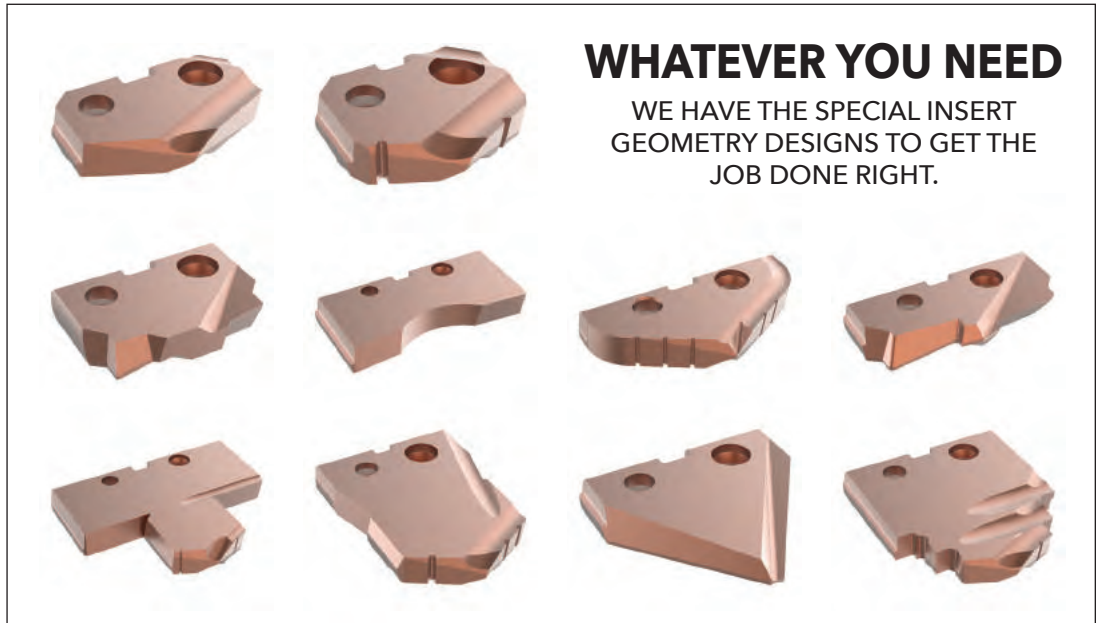

WHATEVER YOU NEED

WE HAVE THE SPECIAL INSERT
GEOMETRY DESIGNS TO GET THE
JOB DONE RIGHT.

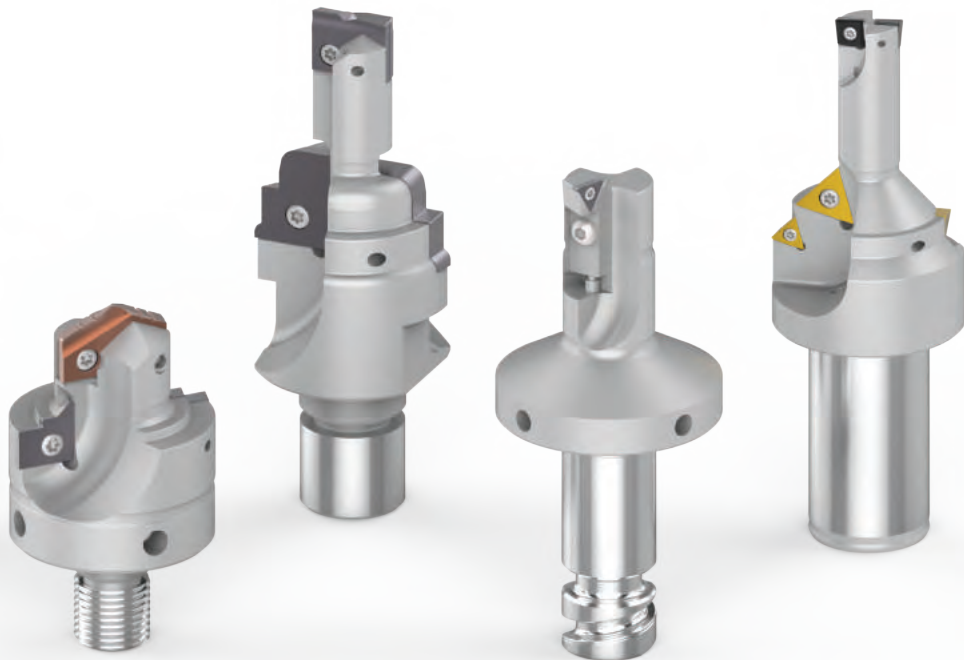

REPLACEABLE INSERT DRILLS

T-A® & IC SPECIALS

- ▶ Can adapt to your specific application(s) to increase process reliability regardless of machine conditions.
- ▶ Special T-A step drills offer a variety of robust insert geometries to combine multiple tools into one. This design reduces tooling costs and improves cycle times.
- ▶ Special form inserts are capable of completing complex forms with precision tolerances to boost productivity and eliminate costly solid carbide tooling.

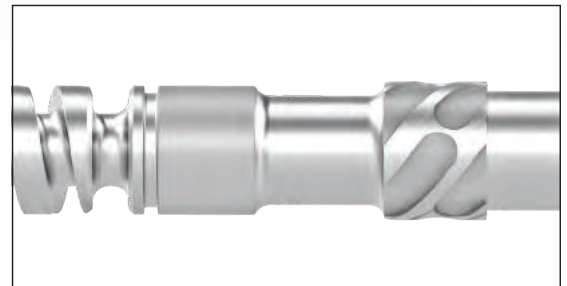

Customer-defined shanks allow the tool to adapt to any machine tool.



CAMSHAFTS

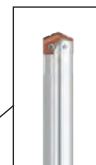

Guided bearing areas improve hole straightness and help the drill maintain stability in deep hole applications.



REPLACEABLE INSERT DRILLS

T-A® GEN2 & T-A® SPECIALS

- ▶ The large assortment of geometries available with the T-A drilling system allows for a consistent drilling process you can rely on regardless of material.
- ▶ Utilizing replaceable inserts increases your productivity by reducing setups and down times.
- ▶ The Notch Point® geometry on the T-A GEN2 insert improves stability and hole straightness.





CRANKSHAFTS



Insert geometries can combine multiple steps into one to reduce tooling costs and improve cycle times.



REPLACEABLE INSERT DRILLS

T-A[®] SPECIALS

- ▶ By combining multiple steps, you can drill, chamfer, and spot in a single operation. Eliminating steps reduces cycle time, which can lead to large cost savings.
- ▶ Not only can holder bodies be modified to include steps, but inserts can also be designed to eliminate multiple operations.
- ▶ Special holder designs that utilize standard inserts reduce costs and lead times, and replaceable inserts protect your investment in the tool.

SOLID CARBIDE DRILLS

SUPERION[™] STEP DRILLS

- ▶ Multi-step carbide tooling is available in different geometry and coating options to optimize your application.
- ▶ Superion tooling helps reduce your cost per part and improve your holmaking process by overcoming chip formation issues, reducing cycle times, and increasing tool life.



CONNECTING RODS & ROCKER ARMS



WOHLHAUPTER® ROUGH & FINISH BORING TOOLS

COMBI-LINE

- ▶ Allows you to rough and finish in one pass.
- ▶ Decreases cycle time and tool changes.



SOLID CARBIDE THREAD MILLS

THREADMILLS USA™

- ▶ Thread mills drastically reduce the occurrences of scrap when compared to taps, and this advantage makes them desirable when manufacturing large and/or costly components.
- ▶ One tool can run both right and left threads, reducing your inventory requirements.
- ▶ Available with coolant through capabilities.



AXLES & WELDMENTS



INDEXABLE CARBIDE DRILLS
OPENING DRILL®

- ▶ Provides ideal performance on low horsepower machines while maintaining high penetration rates. These capabilities make the drill an excellent solution for large holes.
- ▶ Opens an existing hole in a single operation.
- ▶ Eliminates multiple boring passes to improve cost-per-hole and decrease cycle time.

DEEP HOLE INDEXABLE CARBIDE DRILLS
APX™ MODULAR DRILL

- ▶ The hybrid design provides the centering and stability of a spade drill while achieving higher spindle speeds on low horsepower machines, taking advantage of power curves on modern CNC machines.
- ▶ Ideal solution for large diameter deep hole applications.



▶ YOKES



The 2 twisted coolant holes provide superior chip evacuation.



INDEXABLE CARBIDE DRILLS

4TEX® DRILL

- ▶ The robust design allows for reliability in interrupted cuts and undesirable rigidity even when the material is difficult to machine.
- ▶ The single effective cutting on light-duty machines increases penetration rates.
- ▶ Strengthened core and increased coolant volume improve the hole size and chip evacuation.

REPLACEABLE INSERT FORM DRILLS

T-A® FORM DRILL

- ▶ Save time and money by implementing a multi-step tool to reduce your overall process time.
- ▶ Special form inserts are capable of completing complex forms with precision tolerances to boost productivity and eliminate costly solid carbide tooling.
- ▶ Utilize the full range of T-A insert capabilities, including multiple diameters, coatings, substrates, and geometries, without ever replacing the holder.



The replaceable head style allows for multiple diameters and/or coatings to be used within the same arbor.



68% TOOL LIFE INCREASE

ALVAN® Replaceable Head Reamer

CUSTOMER'S OBJECTIVE: INCREASE TOOL LIFE

Ø	SPEED	FEED	PREVIOUS TOOL LIFE	ALLIED'S TOOL LIFE
1.6250"	435 SFM	0.035 IPR	1,400 parts	4,400 parts

You might be missing big-time tool life savings

When it comes to manufacturing yokes, you could be missing out on some big-time tool life increases. How do you know if you're using the best tooling? Our customer, who manufactures yokes from 1141 Steel and Ductile Iron, found a new tooling solution that blew their minds.

Previously, the best their tooling ever produced was 1,400 parts in the 1141 steel. Our ALVAN® Replaceable Head Reamer produced 4,400 parts. That's a 68% increase in their tool life.

In Ductile Iron, our customer's previous reamers had an average tool life between 250 - 300 parts. Before our ALVAN® Reamer had finished testing, the customer was already at 800 parts (and the reamer was still in great shape).

Based on these changes, our customer projected \$150,000 annual cost savings.

Could you improve your tool life with a simple tooling switch? Give us a call, and we'd be thrilled to set up a test in your facility to find out.

REPLACEABLE HEAD REAMERS BY S.C.A.M.I.®

ALVAN® REAMERS

- ▶ Replaceable head functionality increases tool life and reduces set-up times which can increase your cost savings while also providing superior hole quality.
- ▶ Provides tight tolerances (± 0.0002 ") and improves the surface finish of the hole.

*\$150,000
annual cost savings*



TRANSMISSION SHAFTS



Reduce TIR with \varnothing Adjustment

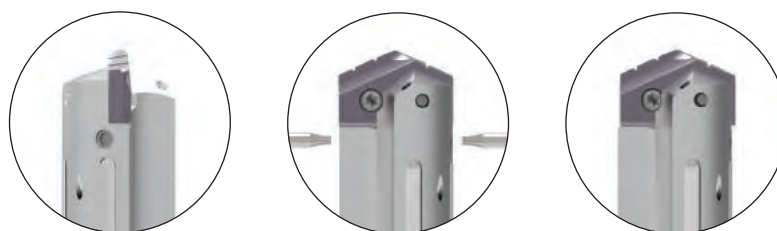

The adjustable screw pins provide the ability to adjust the T-A blade to account for and reduce TIR without increasing setup times.

Improve Stability and Chip Evacuation
with Multiple Coolant Outlets

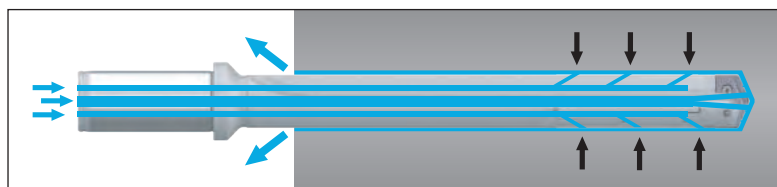

Multiple coolant outlets along the body provide a hydro bearing around the tool, keeping it stable in deeper holes. The increased stability creates a straighter hole with higher finish.

REPLACEABLE INSERT DRILLS

T-A[®] STEALTH DRILL

- ▶ This specially designed guided T-A holder, paired with the versatility of the T-A insert, makes your difficult deep hole drilling applications worry-free.
- ▶ Handles interruptions and angled breakouts with ease.
- ▶ The increased coolant volume increases stability in deep holes and improves chip evacuation.
- ▶ Guided wear pads improve hole straightness.

CHIPS DON'T LIE...



Competitor Chips

T-A® Stealth Drill Chips

...NEITHER DOES FINISH

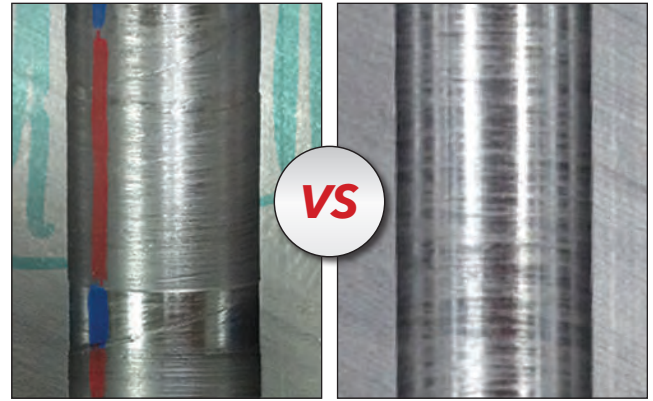

Competitor Surface Finish

T-A® Stealth Drill Surface Finish

*\$240,000
annual scrap savings*

75% TOOL LIFE INCREASE

Special T-A® Stealth Drill

CUSTOMER'S OBJECTIVE: REDUCE SCRAP	
PREVIOUS MONTHLY SCRAP	NEW MONTHLY SCRAP
\$20,000	\$0

What's the true impact of scrap?

Manufacturing scrap is one of the worst costs you can have. The lost material combined with the time and labor to produce the part can add up fast. When our customer began to drown in scrap costs, they knew it was time to find an answer.

The tooling they used on their engine blocks resulted in scrap costs of \$20,000 a month. We used an engineered special called the T-A® Stealth Drill to combat the issue. After testing the drill, our customer didn't just reduce the scrap – they eliminated it altogether.

Along with the elimination of scrap, our tooling provided tool life of 1,200 holes, which was a 75% increase over the 300-hole life of their previous tooling. With no scrap and a much longer tool life, the process transformed from a nightmare into a dream come true.

Our customer gained back \$240,000 a year just by finding the right tooling solution.

Are you scrapping cash that could go to your bottom line?



FLYWHEELS



Different geometry/coating combinations designed for ISO-specific materials.

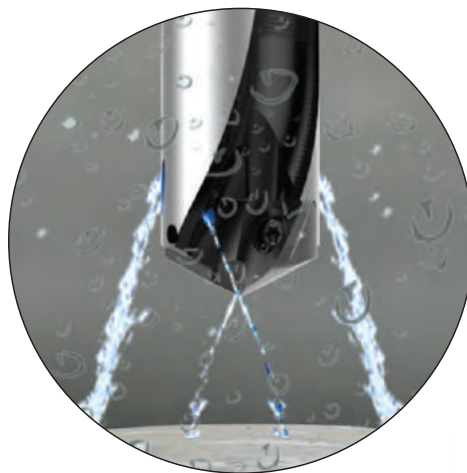

HIGH PENETRATION DRILLS

GEN3SYS® XT PRO

- ▶ With increased coolant at the cutting zone, the XT Pro dissipates heat, which is critical in extending tool life.
- ▶ The increased coolant flow also allows the tool to achieve maximum penetration rates, which can help increase your throughput.
- ▶ The XT Pro holder has additional flute volume that improves chip evacuation.

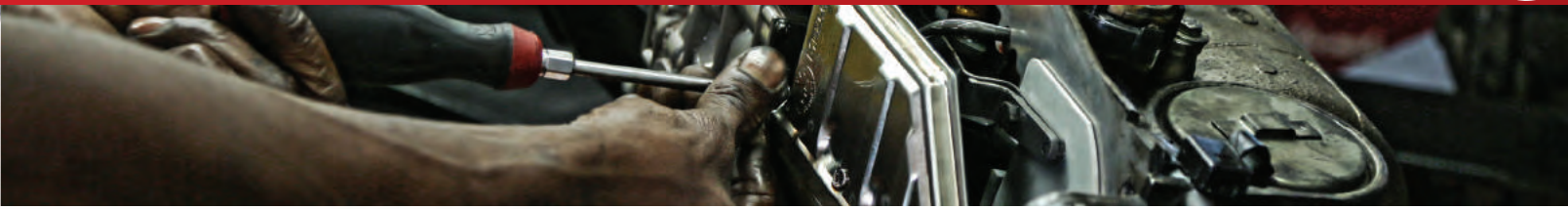

HYDRAULIC PUMP HOUSINGS

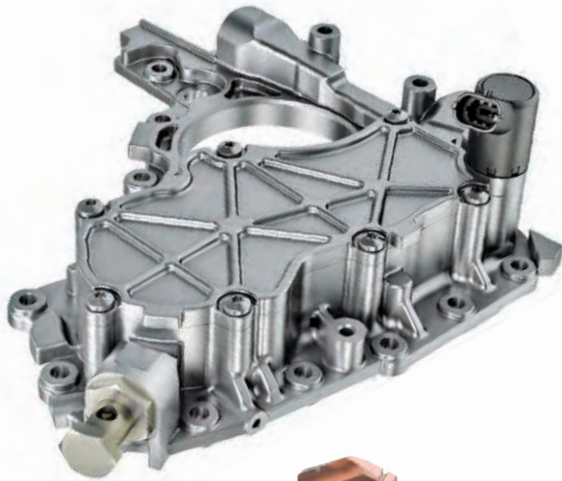

Expandable up to 4% nominal diameter to accommodate for wear.



PORT & THREAD FINISHING KITS

ACCUPORT & ACCUTHREAD™

- ▶ Port kits incorporate the AccuThread solid carbide thread mill to increase the manufacturing flexibility by allowing hydraulic ports to be produced in just two operations.
- ▶ The kit includes the AccuPort 432® contour cutter with a dedicated AccuThread solid carbide thread mill (T-A® inserts and port form inserts also included).
- ▶ Available in a variety of geometries for precision finishes.
- ▶ Asymmetrical cutting edges provide excellent hole roundness.



RING STYLE REAMERS BY S.C.A.M.I.®

ALVAN® REAMERS

- ▶ The cutting ring can be expanded to increase tool life. The ring can also be reconditioned, which makes it an excellent solution for reaming large diameters.
- ▶ Available in a variety of geometries for precision finishes.
- ▶ Asymmetrical cutting edges provide excellent hole roundness and improve surface finish.



TRANSMISSION HOUSINGS

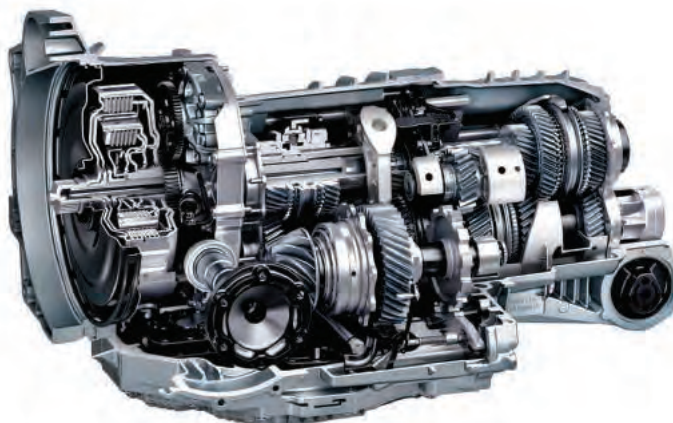

Replaceable cartridges and inserts reduce machine downtime and maximize your investment.



INDEXABLE CARBIDE DRILLS

REVOLUTION DRILL®

- ▶ Provides ideal performance on low horsepower machines while maintaining high penetration rates. These capabilities make the drill an excellent solution for large holes up to 4.00" (101mm).
- ▶ Robust geometry allows the tool to drill through uneven surfaces and interrupted cuts.
- ▶ Drills from solid with no pilot hole required.

WOHLHAUPTER® FINISH BORING TOOLS

365 BORING HEAD

- ▶ Vernier scale for fast and easy 0.0001" (0.002mm) diameter adjustments.
- ▶ Internal balancing mechanism allows for high spindle speeds, which can increase your throughput.



WHEEL RIMS & HUBS



REPLACEABLE INSERT & SOLID CARBIDE DRILLS

T-A® & SUPERION RIM DRILLS

- ▶ The combination T-A drill can be designed to your specific part and reduces the number of tools required to produce lug holes. The indexable and replaceable inserts reduce your tooling costs.
- ▶ The premium automotive industry uses tolerances that require solid tools. Superior brazed carbide tooling is a cost-effective way to achieve the required profiles in the high production environments of wheel manufacturers.

REPLACEABLE INSERT DRILLS

DRILL & CHAMFER TOOLS

- ▶ Avoid deburring costs and the costs of multiple set-ups by utilizing circular interpolation and our drill/chamfer/back chamfer tools to clean up both the entry and exit edges of the hole.
- ▶ The back chamfer feature is built into the insert, allowing you to perform multiple operations with ONE tool. This advantage decreases your inventory costs and lowers your cycle time.



BRAKE CALIPERS

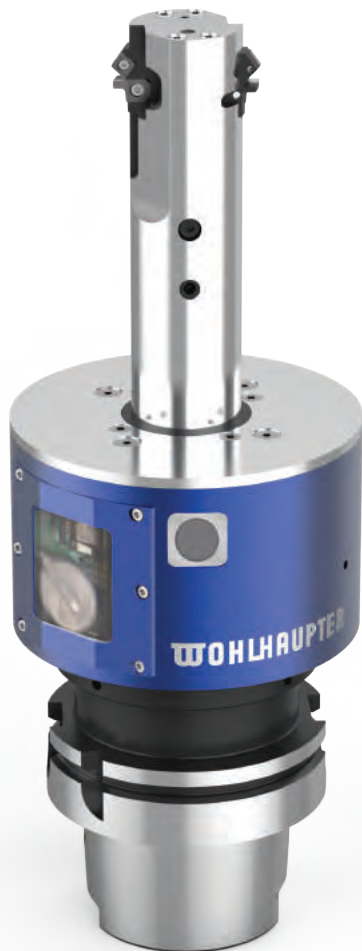

WOHLHAUPTER® FINISH BORING TOOLS

EK GROOVER

- ▶ Create complex grooves faster and deeper than ever before.
- ▶ Eliminate chatter in hard-to-reach internal forms.
- ▶ The electronically-controlled insert release can be adapted to most machine tools.

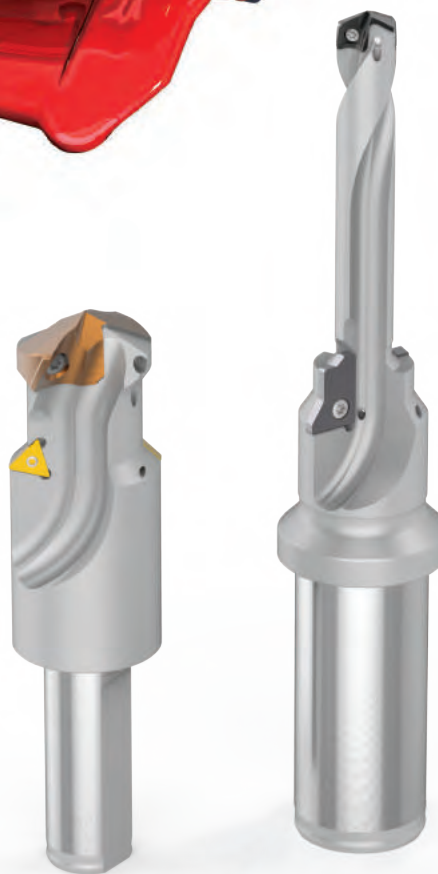

HIGH PENETRATION DRILLS

GEN3SYS® XT SPECIALS

- ▶ Combine multiple operations into one. You can utilize the high penetration rate capabilities of the XT along with a chamfer, back chamfer, and/or multiple step profiles.
- ▶ Special holder bodies utilize standard inserts which saves money and reduces setups and downtime.



BRAKE ROTORS

The replaceable insert and aggressive geometry options allow you to match or outperform penetration rates of solid carbide tooling.



SOLID CARBIDE DRILLS

ASC 320®

- ▶ Tackle a wide variety of applications with the unique combination of geometry and coating options.
- ▶ Achieve high penetration rates in smaller holes (the product line Ø range goes from 3mm - 20mm)
- ▶ The reinforced shank adds increased durability.



STANDARD

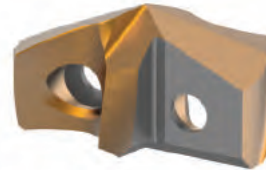

AUSTENITIC STAINLESS

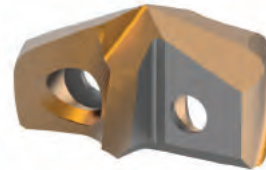

CAST IRON

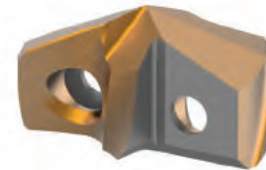

LOW RAKE



HIGH PENETRATION DRILLS

GEN3SYS® XT

- ▶ The ability to replace the inserts on the spindle provides cost benefits by reducing machine downtime and setups.
- ▶ Provides excellent chip control, improved durability, and added stability.
- ▶ Increases penetration rates and tool life.



BRAKE CYLINDERS



Torx screws on the form insert pocket creates adjustability on the form. This feature allows the drill to hold tighter tolerances than standard drills.

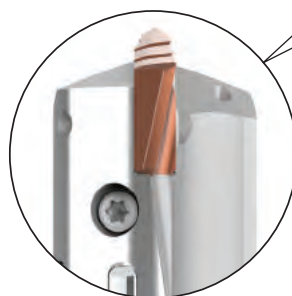

The adjustable screw pins provide the ability to adjust the T-A blade to account for and reduce TIR without increasing setup times.

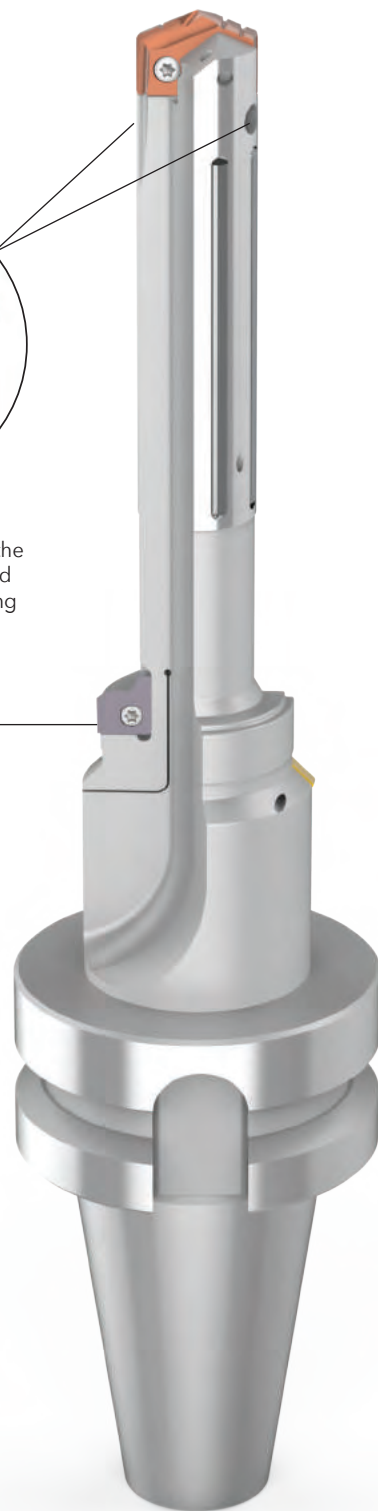

REPLACEABLE INSERT DRILLS

T-A[®] ADJUSTABLE DRILLS

- ▶ Utilizes the same features as the T-A Stealth Drill (see page 10), including the adjustable screw pins on the pilot insert, guided wear pads, and additional coolant outlets.
- ▶ The increased coolant volume improves stability in deep holes and maximizes chip evacuation.
- ▶ Guided wear pads improve hole straightness.



**Whatever type of holmaking you do,
Allied is here to help.**

Whether you're a production facility producing thousands of parts for one customer, or a job shop making a handful of parts for a thousand customers, we're here to make sure the job gets done. Our precision holmaking and finishing solutions are backed by our experienced staff of knowledgeable engineers who are standing by.

Don't hesitate to call us. Let us know what problems you're having and give us a chance to find the solution. Machining is what we do, and we don't mind showing off what we know.

All you have to do is ask.

1.330.343.4283 ext. 7611

For more automotive industry case studies, visit
www.alliedmachine.com/CaseStudies

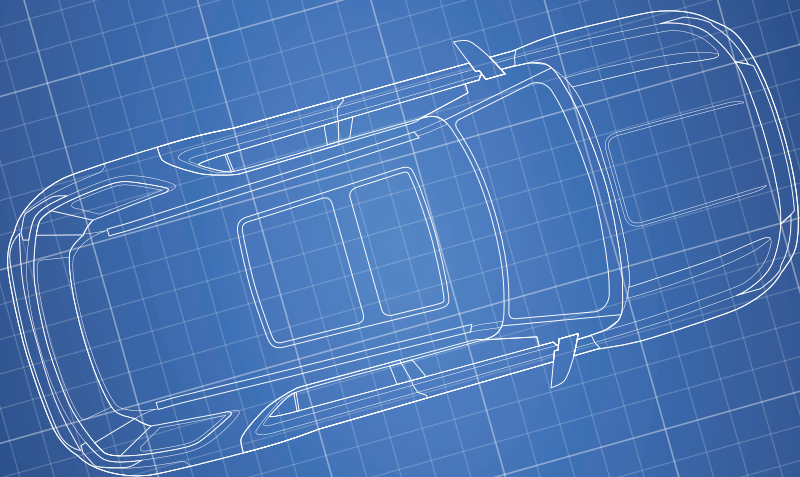

Warranty Information



Allied Machine & Engineering ("Allied Machine") warrants to original equipment manufacturers, distributors, industrial and commercial users of its products for one year from the original date of sale that each new product manufactured or supplied by Allied Machine shall be free from defects in material and workmanship.

Allied Machine's sole and exclusive obligation under this warranty is limited to, at its option, without additional charge, replacing or repairing this product or issuing a credit. For this warranty to be applied, the product must be returned freight prepaid to the plant designated by an Allied Machine representative and which, upon inspection, is determined by Allied Machine to be defective in material and workmanship.

Complete information as to operating conditions, machine, set-up, and the application of cutting fluid should accompany any product returned for inspection. This warranty shall not apply to any Allied Machine products which have been subjected to misuse, abuse, improper operating conditions, improper machine set-up or improper application of cutting fluid or which have been repaired or altered if such repair or alteration, in the judgment of Allied Machine, would adversely affect the performance of the product.

THIS WARRANTY IS IN LIEU OF ALL OTHER WARRANTIES, EXPRESS OR IMPLIED, INCLUDING ANY IMPLIED WARRANTY OF MERCHANTABILITY OR FITNESS FOR A PARTICULAR PURPOSE. Allied Machine shall have no liability or responsibility for any claim, whether in contract, tort or otherwise, for any loss or damage arising out of, connected with, or resulting from the manufacture, sale, delivery or use of any product sold hereunder, in excess of the cost of replacement or repair as provided herein.

Allied Machine shall not be liable in contract or in tort (including, without limitation, negligence, strict liability or otherwise) for economic losses of any kind or for any special, incidental, indirect, consequential, punitive or exemplary damages arising in any way out of the performance of, or failure to perform this Agreement.

ALL PRICES, DELIVERIES, DESIGNS, AND MATERIALS ARE SUBJECT TO CHANGE WITHOUT NOTICE.



Allied Machine & Engineering
Registered to ISO 9001
10001329

United States

Allied Machine & Engineering

120 Deeds Drive
Dover OH 44622
United States

Phone:
+1.330.343.4283

Fax:
+1.330.602.3400

Toll Free USA and Canada:
800.321.5537

Toll Free USA and Canada:
800.223.5140

Allied Machine & Engineering

485 W Third Street
Dover OH 44622
United States

Phone:
+1.330.343.4283

Fax:
+1.330.364.7666
(Engineering Dept.)

Toll Free USA and Canada:
800.321.5537

Europe

Allied Machine & Engineering Co. (Europe) Ltd.

93 Vantage Point
Pensnett Estate
Kingswinford
West Midlands
DY6 7FR England

Phone:
+44 (0) 1384.400900

Wohlhaupter GmbH

Maybachstrasse 4
Postfach 1264
72636 Frickenhausen
Germany

Phone:
+49 (0) 7022.408.0

Fax:
+49 (0) 7022.408.212

Asia

Wohlhaupter India Pvt. Ltd.

B-23, 2nd Floor
B Block Community Centre
Janakpuri, New Delhi - 110058
India

Phone:
+91 (0) 11.41827044

Your local Allied Machine representative:

www.alliedmachine.com

Allied Machine & Engineering is registered by DQS to ISO 9001 10001329



© 2019 Allied Machine & Engineering
Literature Order Number: SOL-AUTO
Publish Date: May 2019