

# MSS

the modular parting, grooving  
and threading system

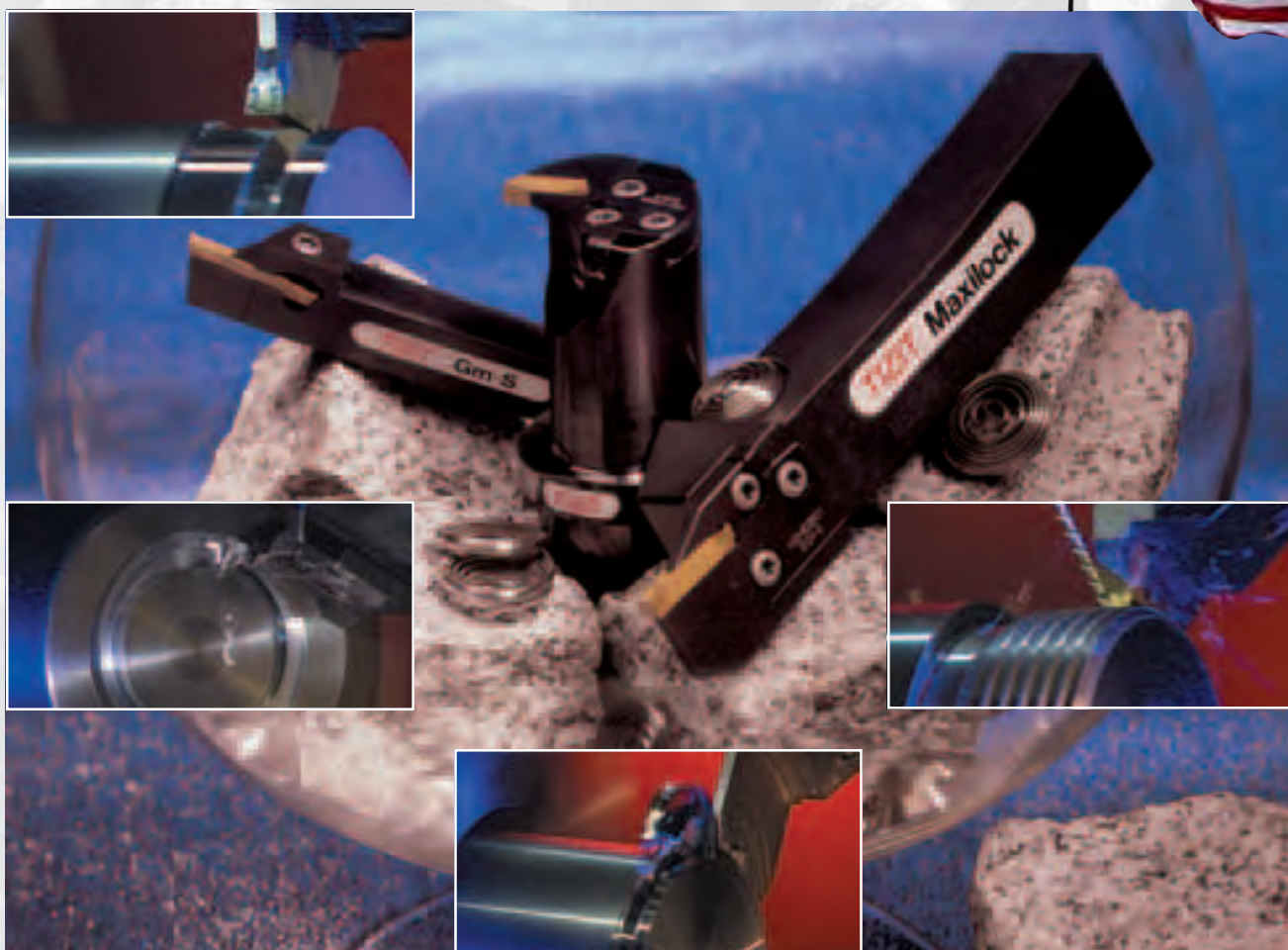

*Flexible, precise, complete*

**PLANSEE TIZIT**



# PLANSEE worldwide



Modern technologies make high demands on the materials used. Implementing new technical ideas therefore often means that material problems must be solved.

PLANSEE is synonymous with innovative application of high-performance material.

With our three business divisions, high-performance material, hard metals and tools as well as sintered

steel, PLANSEE is one of the leading manufacturers of powder metallurgical products and components worldwide.

Our products are characterised by extraordinary properties. They are applied in numerous fields of hightech.

The PLANSEE production sites in the three economic areas Europe, America and Asia and a worldwide

network of distribution companies and sales partners ensure optimum response to customers' needs.



# A Step ahead in Technology



Visit on the Internet at  
[www.plansee.com](http://www.plansee.com)



*"high tech" at the  
TIZIT sintering department*

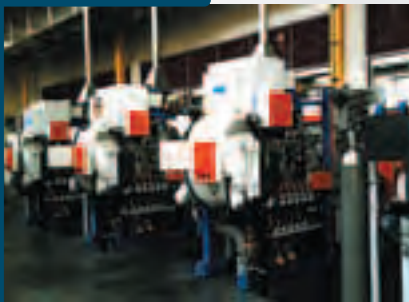

Our facilities and production  
methods correspond to state-of-  
the-art technology



*selected raw materials*

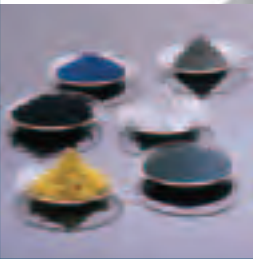

We rely on more than 75 years  
of know-how in the field of  
powder metallurgy

Our quality management systems  
meet the highest standards  
We regularly organize audits



*There's no compromise  
when it comes to quality*

*on the way to the  
PLANSEE Seminar*











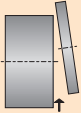



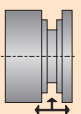



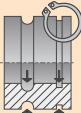

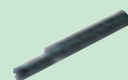

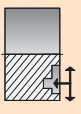
We promote intensive  
dialogue with our business  
partners

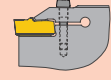
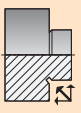

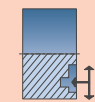
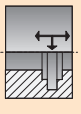

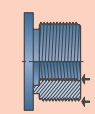
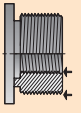
# Contents

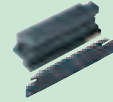
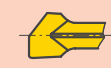
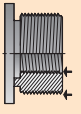
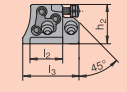
Introduction	Application	Indexable inserts	Tools	Technical information
 <p>page A6 - A11</p>	 <p>page B2 - B15</p>	<p><b>FX</b></p>  <p>page C2 - C6</p>	<p><b>Shanks</b></p>  <p>page D2 - D9</p>	<p><b>Gen. inf.</b></p>  <p>page E2 - E7</p>
 <p>page A12 - A19</p>	 <p>page B16 - B23</p>	<p><b>LX</b></p>  <p>page C7</p>	<p><b>External modules</b></p>  <p>page D10 - D21</p>	<p><b>-FX</b></p>  <p>page E8 - E13</p>
 <p>page A20 - A25</p>	 <p>page B24 - B49</p>	<p><b>GX</b></p>  <p>page C8 - C14</p>	<p><b>Boring bars</b></p>  <p>page D23 - D25</p>	<p><b>-GX / LX</b></p>  <p>page E14 - E24</p>
	 <p>page B50 - B59</p>	<p><b>GX</b></p>  <p>page C16 - C19</p>	<p><b>Internal modules</b></p>  <p>page D26 - D29</p>	<p><b>-LX</b></p>  <p>page E25</p>
	 <p>page B60 - B65</p>	<p><b>GX</b></p>  <p>page C20 - C22</p>	<p><b>Thread</b></p>  <p>page D30 - D35</p>	 <p>page E26 - E29</p>
	 <p>page B66 - B77</p>	<p><b>GmS</b></p>  <p>page C23</p>	<p><b>UTS</b></p>  <p>page D36 - D40</p>	 <p>page E30 - E39</p>
	<p><b>Turning</b></p>  <p>page B78 - B93</p>	<p><b>TC</b></p>  <p>page C24 - C28</p>	<p><b>Block / blade</b></p>  <p>page D41 - D45</p>	<p><b>Special shapes</b></p>  <p>page E40 - E41</p>
	<p><b>Milling</b></p>  <p>page B94 - B99</p>			<p><b>Dimensions</b></p>  <p>page E42 - E43</p>

# “Easy Choice“

Selection has never been so easy!

Easy Choice

The MSS catalog has been divided into 5 chapters.

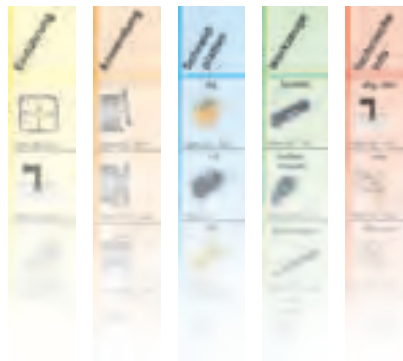

page A6-A7

The different colors of the navigation bars on the right hand side of the catalog make a first quick orientation concerning the single chapters possible. (see picture on the right)

Parting & grooving

page A8

The solution

## Tool selection via the chapter “Application“

page A9

MSS benefit

page A10

MSS system components

page A11

- 1 Look for the machining method of your choice using the right navigation bar.
- 2 In the left hand bar you will find detailed information concerning the respective chapter. Here you can choose the adequate shank type and size.
- 3 All the modules that are suitable for the chosen shank are visualized on the right side at the same height. Choose the parting and grooving depth and width according to your parameters and your tool is complete.
- 4 At the bottom of the page you will receive information about where to find the suitable inserts.
- 5 Please find detailed information about the tool/module selected on the pages which are listed here.



# “Easy Choice“

Selection has never been so easy!

## Chapter “Inserts“



In this bar you will find a description of the possible applications of these inserts.



All the inserts on this page are suitable for the tools and modules listed here.



## Chapter “Tools“



## Chapter “Technical information“

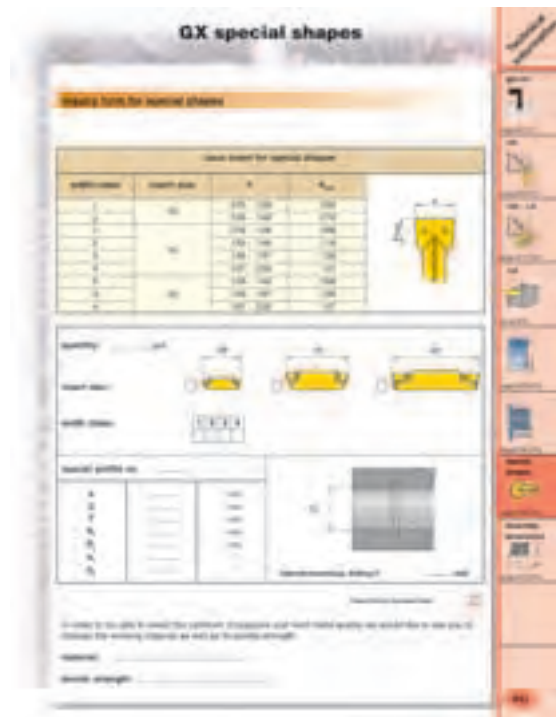

# Parting and grooving

Easy Choice

Both parting and grooving are characterized by a large variety of variations, demanding technology and a complex tool design.

page A6-A7

Parting & grooving

## large variety of variations

page A8

- ⇒ external / internal grooving
- ⇒ radial, axial grooving
- ⇒ grooving
- ⇒ parting
- ⇒ profile grooving
- ⇒ parting, grooving and turning
- ⇒ deep grooving

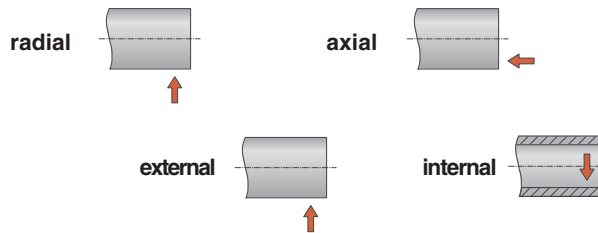

The solution

page A9

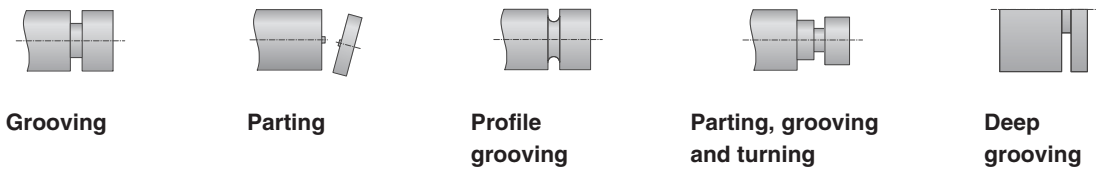

MSS benefit

page A10

MSS system components

page A11

## demanding technology



- ⇒ chip formation
- ⇒ chip evacuation
- ⇒ parallel / flat parting surface
- ⇒ surface finish
- ⇒ formation of burrs when parting tubes
- ⇒ pip formation when parting off
- ⇒  $v_c = 0$  in the center
- ⇒ entire main cutting edge applied

## complex tool design

- ⇒ narrow, long overhang
- ⇒ insert clamping
- ⇒ rigidity
- ⇒ resistant against breakage
- ⇒ easy handling
- ⇒ economy





# The solution !

# MSS

- the modular parting, grooving  
and threading system



In order to be able to meet all demands, state-of-the-art tools have a modular structure.



## system functions

- ⇒ separate shank and module
- ⇒ same interface for all parting, grooving and threading applications
- ⇒ stable, precise connection
- ⇒ extendable through new "modules"
- ⇒ easy handling
- ⇒ clamping functions optimized for respective application



# MSS benefits

Easy Choice

page A6-A7

Parting and  
grooving

page A8

The solution

page A9

MSS  
benefit

page A10

MSS  
system  
components

page A11

# MSS

- the modular parting, grooving  
and threading system

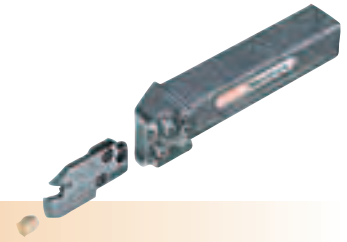

## Flexibility

- ⇒ adaptable to machining task
- ⇒ a system for all parting, grooving and threading methods
- ⇒ well-suited for semi-standard tools

## Precision

- ⇒ accurate repeatability for change of module
- ⇒ reduced set-up times
- ⇒ high quality parts

## Stability

- ⇒ machining safety
- ⇒ parting, grooving and longitudinal turning possible

## Simplicity

- ⇒ quick module change in case of tool breakage,  
low down-times
- ⇒ easy handling

## Economy

- ⇒ few products in stock make large variety  
of combinations possible
- ⇒ in case of tool breakage only change module

## Completeness

- ⇒ components for all work pieces and materials



# MSS system components

# MSS

- the modular parting, grooving and threading system

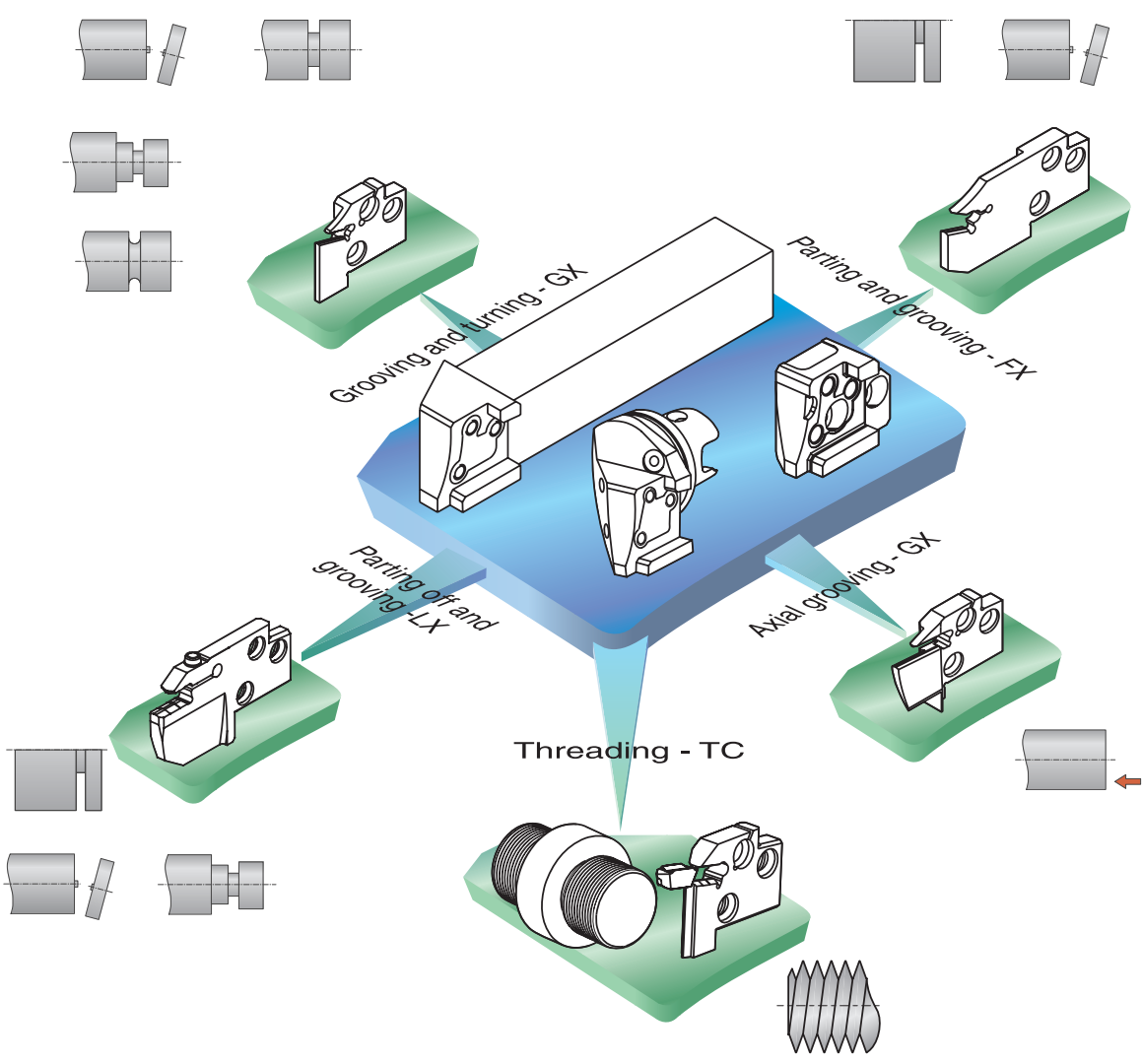
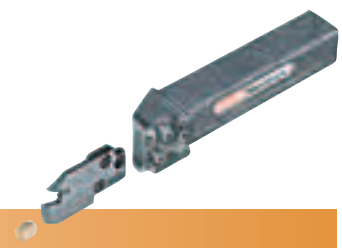

Shanks with  $\square < .47$  inch and boring bars  $\varnothing \leq .63$  inch are available as compact tools.



page A6-A11



page A12-A19



page A20-A25

# The interface

Interface

page A12

Modules

page A13

Indexable  
inserts

page A14

Width  
classes

page A15

Assembly  
size

page A16

Tool shank  
description

page A17

Module  
description

page A18

Insert  
description

page A19

# MSS

- the modular parting, grooving  
and threading system

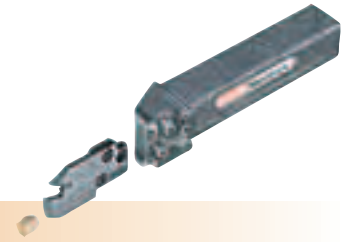

## the strong connection

module unclamped:

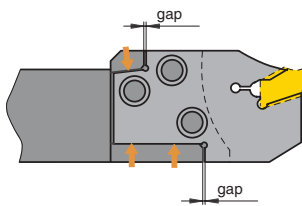

⇒ gap between module  
and face abutment for  
axial clamping

module clamped:

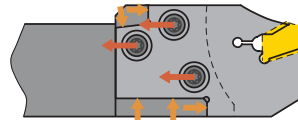

⇒ axial clamping with face  
abutment  
⇒ connection free from play  
therefore highest stability

## clamping functions

**FX / GX:**  
self-clamping  
indexable inserts

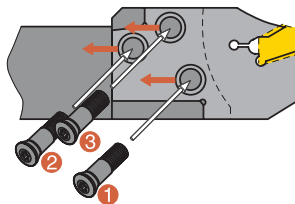

Screws 1, 2 and 3 are used to  
clamp the module. The insert is  
self-clamping.

**GX / TC:**  
active insert clamping

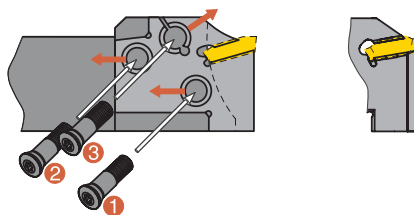

Screws 1 and 2 are used to  
clamp the modules.  
**Important:** primary and  
secondary clamping necessary  
for screws 1 and 2.  
Subsequently the insert is  
clamped by means of screw 3.

**LX:**  
active insert clamping

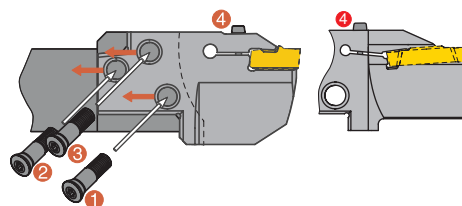

Screws 1, 2 and 3 are used to  
clamp the modules. The insert is  
clamped through the elastic  
deformation of the module via  
the additional screw 4.



# The modules

# MSS

- the modular parting, grooving and threading system



Grooving / parting

**FX**

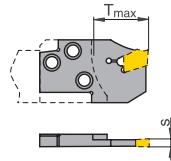

$T_{max} = 1.77 \text{ inch}^1$   
 $s = .086 - .256 \text{ inch}$

Grooving / parting / longitudinal turning / axial grooving

**GX external**

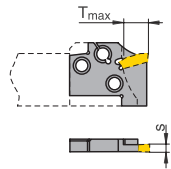

$T_{max} = .83 \text{ inch}^1$   
 $s = (.024) .079 - .315 \text{ inch}$

**GX internal**

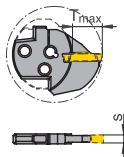

$T_{max} = .75 \text{ inch}^1$   
 $s = (.024) .079 - .256 \text{ inch}$

Grooving / parting / longitudinal turning / axial grooving

**LX**

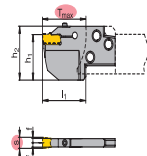

$T_{max} = 1.77 \text{ inch}$   
 $s = .315 \text{ inch}$

Thread turning and milling

**TC**

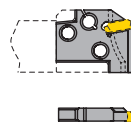

Pitch : ISO 0,5 - 5,0 mm  
 BSW 28 - 5 T.P.I.

<sup>1)</sup> Details see pages D10 - D21!

## system characteristics

- ⇒ precision investment castings made of tempered steel with high strength
- ⇒ locating surfaces for MSS interface ground with highest precision
- ⇒ ground chip pocket

## benefit

- ⇒ long tool life / high rigidity
- ⇒ accurate repeatability
- ⇒ safe and precise insert clamping

# Indexable inserts

# MSS

- the modular parting, grooving and threading system

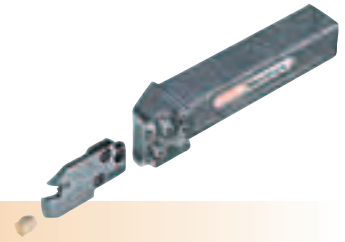

Interface

page A12

Modules

page A13

Indexable inserts

page A14

Width classes

page A15

Assembly size

page A16

Tool shank description

page A17

Module description

page A18

Insert description

page A19

## Grooving / parting

### FX



.087 - .381	.087 - .256	

## Grades / geometry for:

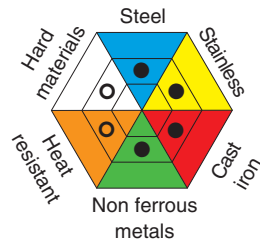

## Grooving / parting / longitudinal turning / axial grooving

### GX



insert size					upon request
09	.024 - .128	.031 - .047	.079 - .138		
16	.024 - .207	.031 - .118	.079 - .236		
24		.118 - .157	.118 - .236		

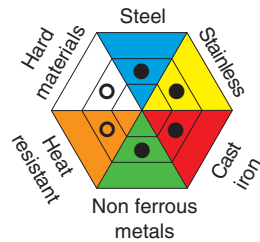

## Grooving / parting / longitudinal turning / axial grooving

### LX

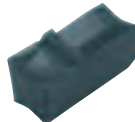

.157	.315

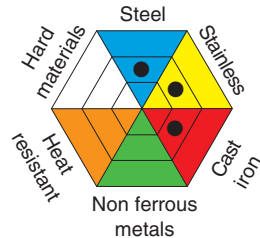

## Thread turning and milling

### TC



ISO 60° 	BSW 55° 
Full and partial profile external / internal	Full and partial profile external / internal
pitch 0,5 - 5,0 mm	28 - 5 T.P.I.

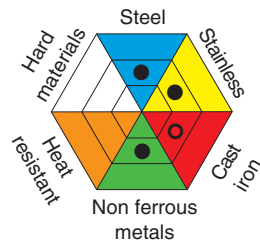

o = extended application  
● = main application

- ⇒ according to the respective application either precision ground or sintered
- ⇒ optimized geometries for all important materials
- ⇒ safety through ideal combination of substrate and coating
- ⇒ all indexable inserts for aluminum machining are microfinished

# The width classes ( GX system )

# MSS

- the modular parting, grooving  
and threading system

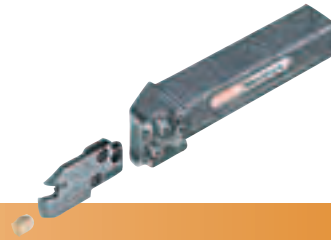

Width class	-1	-2	-3	-4	-5
<b>Parting and grooving modules</b>	 .051	 .079	 .116	 .165	 .232
<b>Parting and grooving inserts</b>	 .079 - .108	 .109 - .148	 .148 - .197	 .197 - .256	 .315

Module description:

MSS-E20R12-GX16-2

Insert description:

GX16-2E3.00N0.30

Width class 1)

The parting and grooving widths of the MSS system are divided into width classes. Every width class represents a certain range of parting and grooving widths. The appropriate module can be assigned to the selected grooving width by means of the width class.

1) Ideally the module and the insert have the same width class. This combination results in the best possible machining safety.





# Assembly size ( GX system )

Interface

page A12

Modules

page A13

Indexable  
inserts

page A14

Width  
classes

page A15

Assembly  
size

page A16

Tool shank  
description

page A17

Module  
description

page A18

Insert  
description



page A19



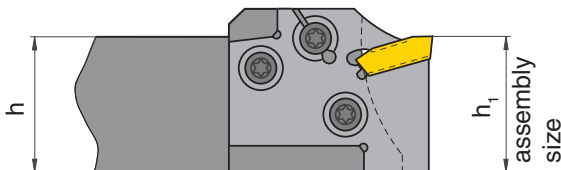
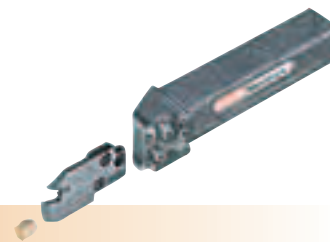



# MSS

- the modular parting, grooving  
and threading system



The assembly size is determined by the shank dimensions of the MSS basic holders. In this manner the right basic holder can be assigned to the correct module size and vice versa. The following tables will give you an overview of the width classes and insert sizes which are available for the respective assembly sizes.

Assembly size	GX								
									
	Width class								
	1	2	3	4	1	2	3	4	
10	■								
12	■				■				
16	■				■				
20	■				■				
25	■				■				
32		■			■				
40					■				

Assembly size	GX					
	Insert size					
	09		16		24	
						
10	●					
12	●	●				
16	●	●				
20		●	●		●	
25		●	●	●	●	
32			●	●	●	
40				●	●	●



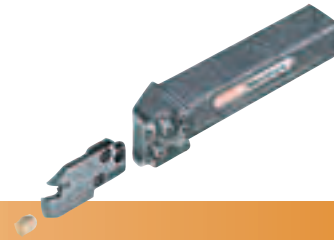

# System description

# MSS

- the modular parting, grooving and threading system

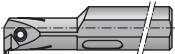

## basic holder designations

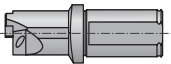
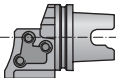
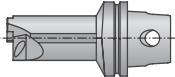
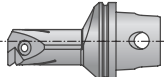
	UTS system	UTS assembly size	MSS system	E = external / I = internal	Assembly size	Execution	Approach angle	Shank section / execution	Shank length / insert system
				E	10	R	00	- 06	
				I	12	R	90	- 2,5D - GX09	
				E	12	R	00	- 08 - TC16	
			MSS	E	25	R	00	- 16	
			MSS	E	25	R	00	- AD	
			MSS	I	25	R	90	- 1,5D	
	UT	40	MSS	E	25	R	00		
	UT	40	MSS	I	32	R	90	- 2D	
	UT	40	MSS	I	32	R	90	- 2D - TC16	



# System description

Interface

page A12

Modules

page A13

Indexable  
inserts

page A14

Width  
classes

page A15

Assembly  
size

page A16

Tool shank  
description

page A17

Module  
description

page A18

Insert  
description



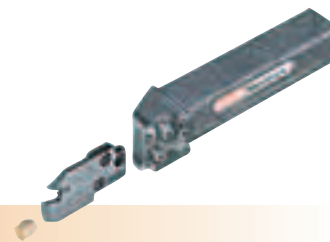

page A19

# MSS

- the modular parting, grooving  
and threading system

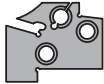

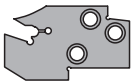
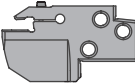
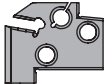
## module designations

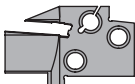
	MSS system	E = external / I = internal	Assembly size	Execution	Maximum grooving depth	Insert system	Insert size / grooving width	Width class	Diameter range D <sub>min</sub> - D <sub>max</sub>
	MSS	- E	25	R	12	- GX	16	- 2	
	MSS	- I	25	R	06	- GX	09	- 1	
	MSS	- E	25	R	20	- FX	3.1		
	MSS	- E	32	N	45	- LX			
	MSS	- E	25	R		- TC	16	- 2	
	MSS	- I	32	R		- TC	16	- 2	
	MSS	- E	25	R	15	- GX	24	- 3	A 70-100





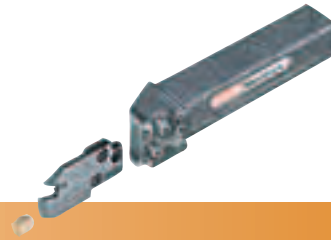

# System description

# MSS

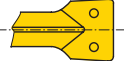
- the modular parting, grooving and threading system

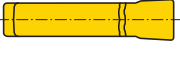
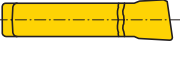
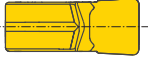

## insert designations

	Insert system	Insert size		Width class	Insert shape / application	Width / pitch	Execution / thread standard	Corner radius / angle		Chip groove code
	GX	16	-	2	E	3.00	N	0.30	-	Code
	GX	16	-	2	R	1.50	N		-	Code
	GX	16	-	2	S	1.00	R			
	FX					3.10	N	0.20	-	Code
	FX					3.10	R	5	-	Code
	LX		-		E	8.00	N	0.8	-	Code
	LX		-		R	4.00	N		-	Code
	TC	16	-	1	E	1.50	ISO		-	Code
	TC	16	-	2	EI	14	W		-	Code





# FX system

FX

page A20

GX

page A21

LX

page A22

TC  
milling

page A23

TC  
turning

page A24 - A25

# MSS

- the modular parting, grooving  
and threading system

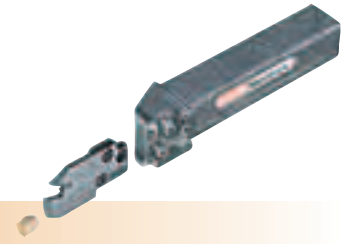

The FX system is characterized by a self-clamping single blade insert for deep grooving of large diameters. FX is directly integrated in the MSS system by means of the respective modules. Additionally the proven block / blade solutions and monobloc tools are available.

shank tool with FX  
grooving module

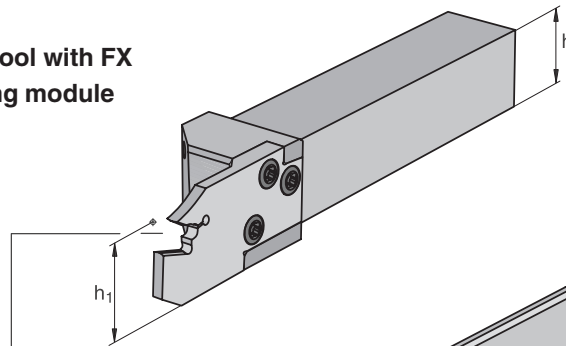

$$h_1 / h = .750 - 1.250 \text{ inch}$$

$$s = .087 - .256 \text{ inch}$$

FX blade

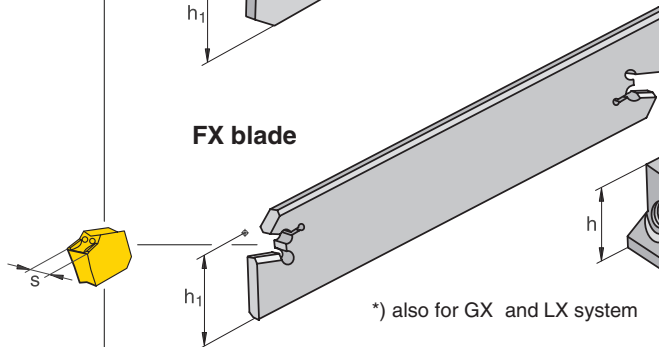

\*) also for GX and LX system

clamp block\*

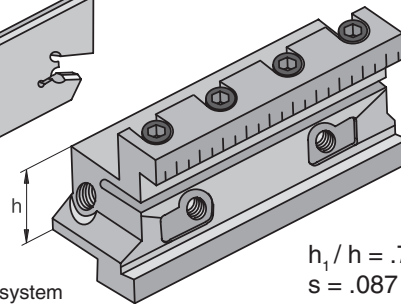

$$h_1 / h = .750 - 1.500 \text{ inch}$$

$$s = .087 - .382 \text{ inch}$$

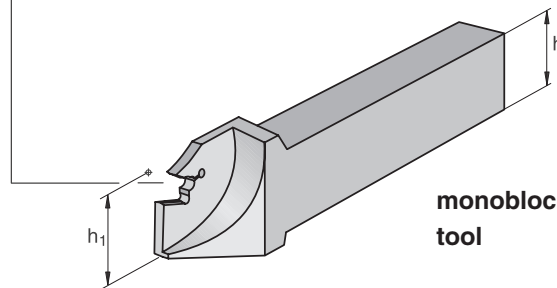
monobloc  
tool

$$h_1 / h = .375 - 1.000 \text{ inch}$$

$$s = .087 - .161 \text{ inch}$$

## system characteristics

- ⇒ self-clamping parting and grooving insert
- ⇒ adjustable blade
- ⇒ single-blade, directly pressed insert

## benefit

- ⇒ easy handling, no clamping parts
- ⇒ grooving depth, overhang optimally adjustable
- ⇒ economical for deep grooving and parting

# GX system

# MSS

- the modular parting, grooving and threading system

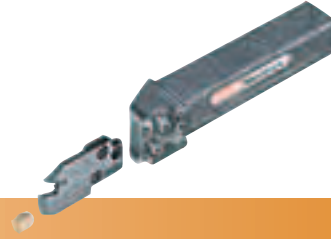

The GX system is characterized by a double-ended insert with numerous application possibilities. It is mostly applied for **radial grooving and turning**. Due to special modules the system can easily be adapted for **axial and circlip grooving**. For GX indexable inserts a range of modules and boring bars for internal grooving is available.

## shank tool with GX grooving module

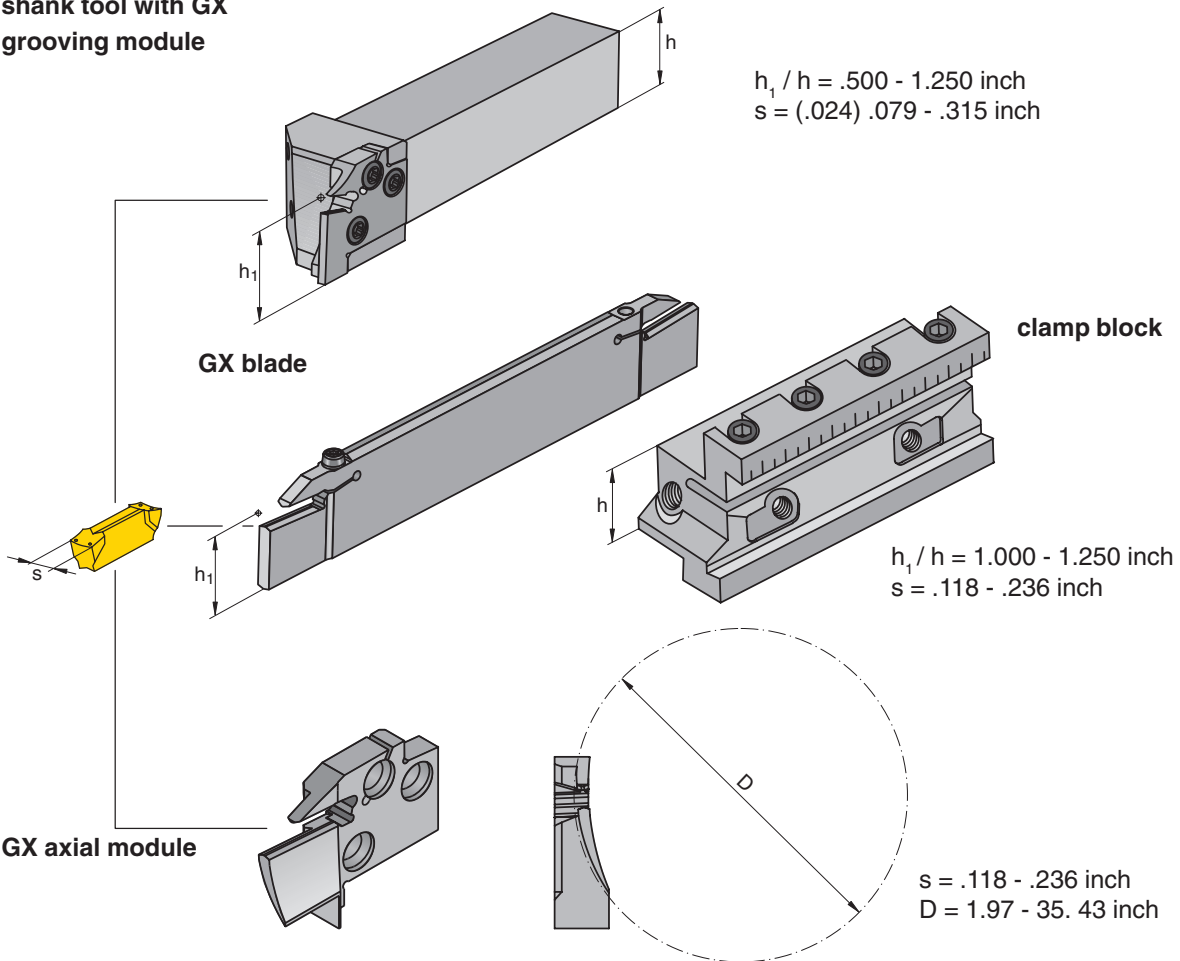

### system characteristics

- ⇒ double-blade insert
- ⇒ ground and directly pressed indexable inserts

### benefit

- ⇒ good economy
- ⇒ optimum solution for all situations



# LX system

# MSS

- the modular parting, grooving and threading system



FX

page A20

GX

page A21

LX

page A22

TC  
milling

page A23

TC  
turning

page A24 - A25

The LX system is characterized by high resistance and stability. It is most suitable for the **production of wide and deep grooves** as well as for parting off large bar diameters.

### LX parting and grooving module

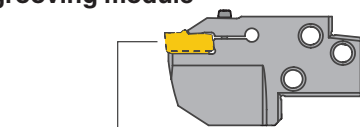

$s = .315$  inch  
 $r = .157$  inch  
 $T_{max} = .98 / 1.26 / 1.77$  inch

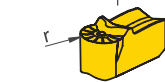
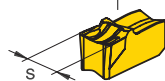

### detail Z

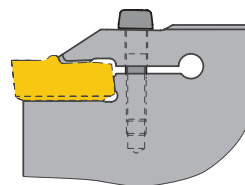

active insert clamping



LX blade

$s = .315$  inch  
 $r = .157$  inch  
 $T_{max} = 3.15$  inch

### application of LX modules

- ⇒ parting
- ⇒ grooving and turning
- ⇒ axial grooving with  $D > 19.68$  inch
- ⇒ internal grooving and turning with  $D > 7.87$  inch

### system characteristics

- ⇒ robust construction
- ⇒ active insert clamping
- ⇒ indexable insert with full radius

### benefit

- ⇒ high machining safety and resistance
- ⇒ well-suited for copy turning

# TC system - thread milling

# MSS

- the modular parting, grooving and threading system

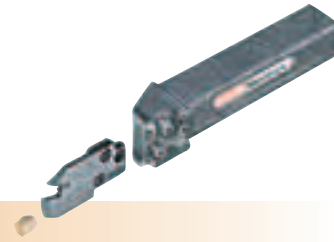

For thread milling and turning the same inserts are applied. With special tool shanks, which are characterized by compact and modular construction, **external as well as internal threads** can be produced on all state-of-the-art machining centers.

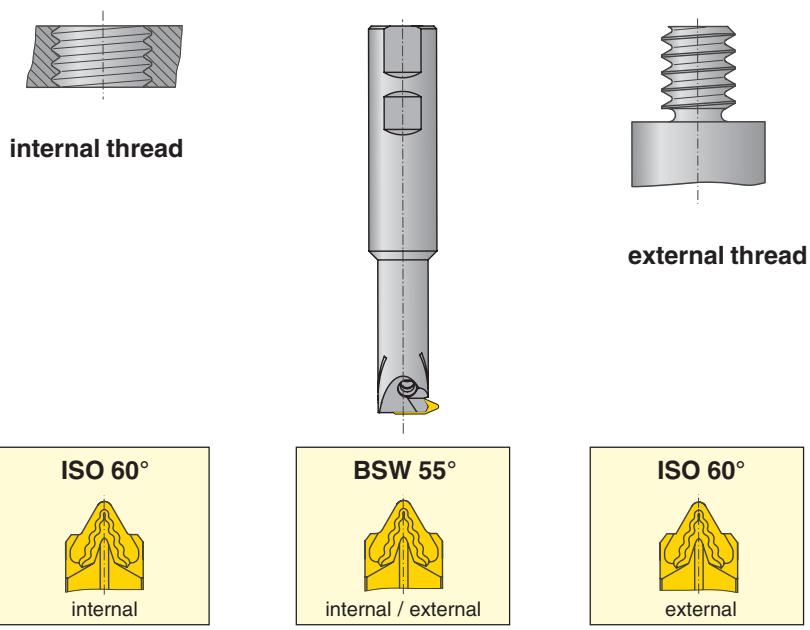

### 3 steps of threading

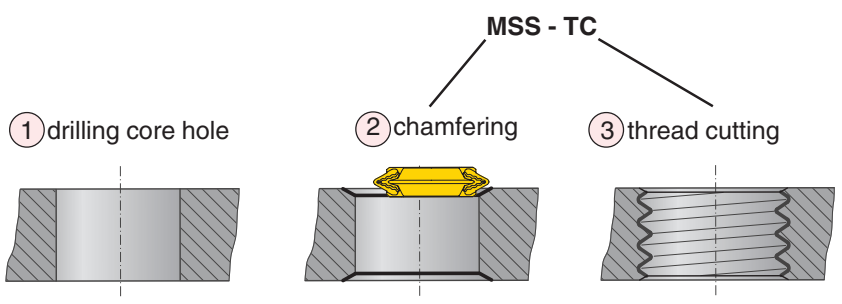

system characteristics	benefit
⇒ turning and milling with the same indexable insert	⇒ flexibility, reduced variety and costs
⇒ single-tooth thread milling	⇒ low machining forces, large overhang possible, high cutting data ( $v_c$ und $f$ ), easy programming
⇒ thread is cut in one pass	⇒ no interruptions or steps in thread





# TC system - thread turning

# MSS

- the modular parting, grooving  
and threading system

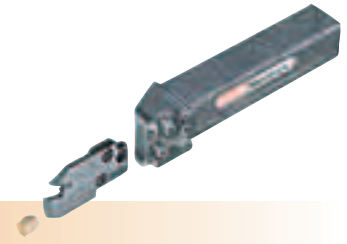

FX

page A20

GX

page A21

LX

page A22

TC  
milling

page A23

TC  
turning

page A24 - A25

The TC system for thread turning is an integrated part of the MSS system. Compared to traditional systems TC offers a series of advantages which are of crucial importance for many threading applications.

## TC system

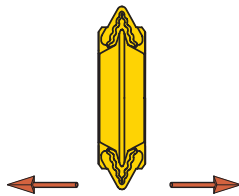

- ⇒ neutral configuration of insert makes operation in both directions possible
- ⇒ only one threading insert per pitch for partial profile and Whitworth thread; only two threading inserts (internal - external) per pitch for ISO threads
- ⇒ reduced stock holding
- ⇒ good chip formation through chip groove with rake angle  $+10^\circ$

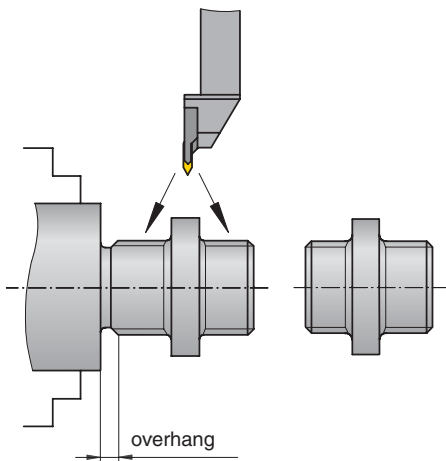

- better economy through
- ⇒ reduced machining times
  - ⇒ less tool changing
  - ⇒ improved stability, small overhang
  - ⇒ material savings
  - ⇒ thread turning between shoulders possible
  - ⇒ fewer tools and indexable inserts

## conventional system

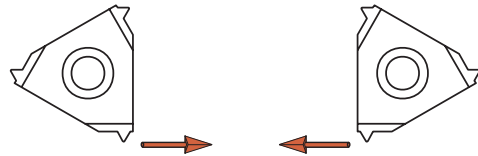

- ⇒ right and left execution of indexable insert, therefore operation only in one direction
- ⇒ for every pitch 4 threading inserts are necessary (right - left, internal - external)

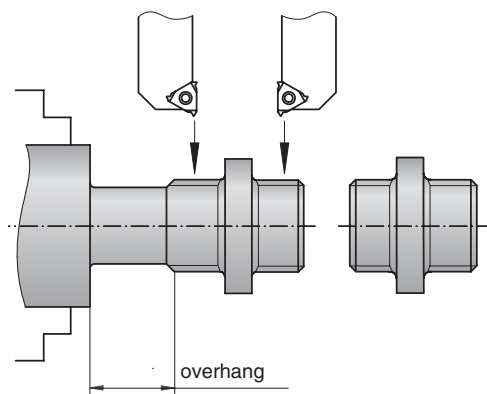

- ⇒ for this machining method 2 tools are necessary
- ⇒ additional loss of stability and material through large overhangs

# TC system - thread turning

# MSS

- the modular parting, grooving and threading system

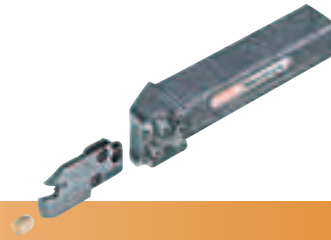

## TC system

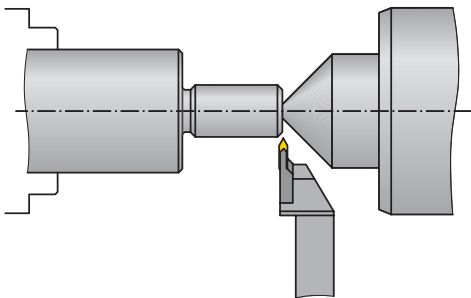

⇒ easy access to work piece  
 therefore use of tailstock also possible with small thread diameters

## conventional system

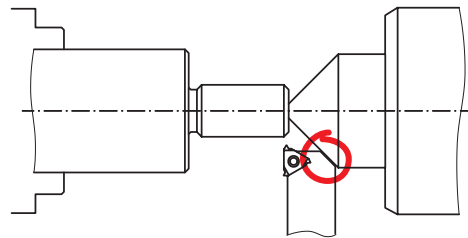

⇒ difficult component access  
 ⇒ danger of collision

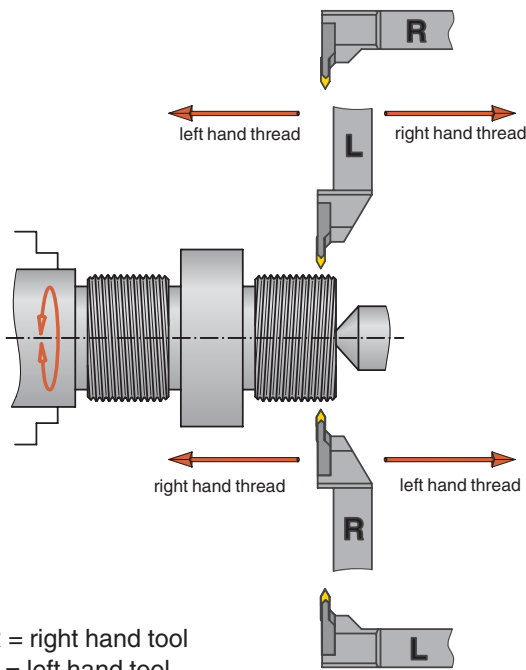

⇒ easy to apply as the tools can be used without correcting helix angle in both directions

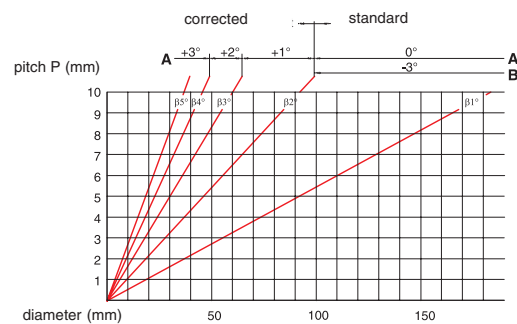
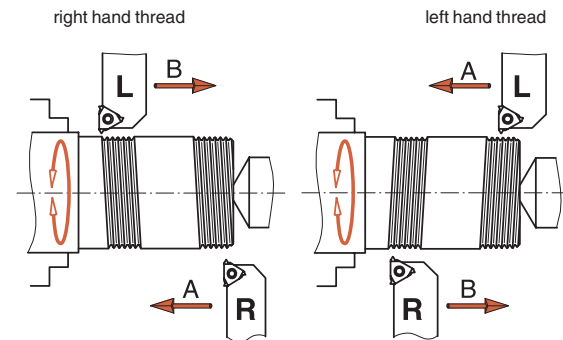

⇒ correction of helix angle necessary, therefore high degree of application know-how necessary  
 ⇒ can only be operated in one direction



# Applications Overview

Application

						Turning	Milling
<b>FX / LX</b>	<b>GX09</b>	<b>GX09...</b>	<b>GX24</b>	<b>GX16</b>	<b>GX09...</b>	<b>TC16</b>	<b>TC16</b>
page B4-B5	page B18-B19	page B27	page B52-B55	page B62-B63	page B69	page B81	page B96
<b>FX / LX</b>	<b>GX / LX</b>	<b>GX ...</b>	<b>GX24</b>	<b>GX16</b>	<b>GX...</b>	<b>TC16</b>	<b>TC16</b>
page B6-B7	page B20-B21	page B28-B33	page B56-B59	page B64-B65	page B70-B73	page B82-B83	page B97
<b>GX</b>	<b>GX / LX</b>	<b>GX ...</b>			<b>GX...</b>	<b>TC16</b>	<b>TC16</b>
page B8-B9	page B22-B23	page B34-B35			page B74-B77	page B84-B85	page B98
<b>GX</b>		<b>GX09</b>				<b>TC16</b>	<b>TC16</b>
page B10-B11		page B37				page B87	page B99
<b>Clamp block and blade</b>		<b>GX...</b>				<b>TC16</b>	
page B12-B13		page B38-B43				page B88-B89	
<b>FX mono</b>		<b>GX...</b>				<b>TC16</b>	
page B14		page B44-B49				page B91	
<b>GMS</b>						<b>TC16</b>	
page B15						page B92-B93	

page B2-B15

page B15-B23

page B24-B49

page B50-B59

page B60-B65

page B66-B77

**Turning**  
  
page B78-B93

**Milling**  
  
page B94-B99



# Parting off Overview

FX / LX



page B4-B5

FX / LX



page B6-B7

GX



page B8-B9

GX



page B10-B11

Clamp block  
and blade



page B12-B13

FX mono



page B14





GMS

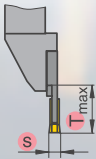
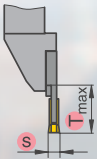
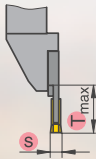
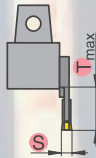
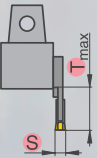
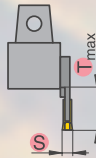
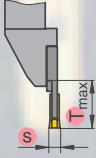
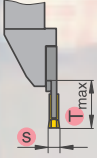
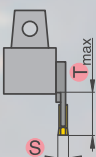
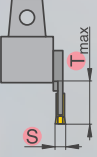

page B15

B2

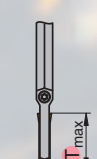
	<p><b>shank 0°</b></p> <p><b>h / b</b> .625/.787 - 1.250/1.250</p>		<p><b>shank 90°</b></p> <p><b>h / b</b> .750/.750 - 1.250/1.250</p>
	<p><b>UTS 0°</b></p> <p><b>d<sub>1</sub></b> 40 - 63 mm</p>		<p><b>UTS 90°</b></p> <p><b>d<sub>1</sub></b> 40 - 63 mm</p>
	<p><b>shank 0°</b></p> <p><b>h / b</b> .625/.787 - 1.250/1.250</p>		<p><b>shank 90°</b></p> <p><b>h / b</b> .750/.750 - 1.250/1.250</p>
	<p><b>UTS 0°</b></p> <p><b>d<sub>1</sub></b> 40 - 63 mm</p>		<p><b>UTS 90°</b></p> <p><b>d<sub>1</sub></b> 40 - 63 mm</p>
	<p><b>clamp block</b></p> <p><b>h / b</b> .750/.700 - 1.500/1.450</p>		<p><b>split clamp block</b></p> <p><b>h / b</b> .750/.700 - 1.250/1.200</p>
	<p><b>shank 0°</b></p> <p><b>h / b</b>      <b>s = .087 - .161</b> .375/.375 - 1.000/.750      <b>D<sub>max</sub> = 1.18 - 1.97</b></p>		
	<p><b>shank 0°</b></p> <p><b>h / b</b>      <b>s = .118</b> .630/.472      <b>T<sub>max</sub> = .55</b></p>		

 <p><b>module FX short</b></p> <p><math>s = .087 - .256</math> <math>T_{max} = .79 - 1.26</math></p>	 <p><b>module FX long</b></p> <p><math>s = .122 - .256</math> <math>T_{max} = 1.38 - 1.77</math></p>	 <p><b>module LX</b></p> <p><math>s = .315</math> <math>T_{max} = .98 - 1.77</math></p>
 <p><b>module FX short</b></p> <p><math>s = .087 - .256</math> <math>T_{max} = .79 - 1.26</math></p>	 <p><b>module FX long</b></p> <p><math>s = .122 - .256</math> <math>T_{max} = 1.38 - 1.77</math></p>	 <p><b>module LX</b></p> <p><math>s = .315</math> <math>T_{max} = .98 - 1.77</math></p>
 <p><b>module GX16</b></p> <p><math>s = .087 - .256</math> <math>T_{max} = .47</math></p>	 <p><b>module GX24</b></p> <p><math>s = .118 - .236</math> <math>T_{max} = .83</math></p>	
 <p><b>module GX16</b></p> <p><math>s = .087 - .256</math> <math>T_{max} = .47</math></p>	 <p><b>module GX24</b></p> <p><math>s = .118 - .236</math> <math>T_{max} = .83</math></p>	
 <p><b>blade FX</b></p> <p><math>s = .087 - .382</math> <math>T_{max} = .98 - 3.15</math></p>	 <p><b>blade GX</b></p> <p><math>s = .118 - .236</math> <math>T_{max} = .83</math></p>	 <p><b>blade LX</b></p> <p><math>s = .315</math> <math>T_{max} = 3.15</math></p>

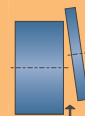

page B2-B15

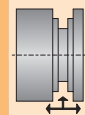

page B16-B23

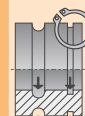

page B24-B49

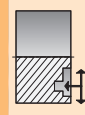

page B50-B59



page B60-B65

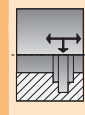

page B66-B77

turning

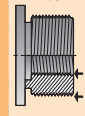

page B78-B93

milling

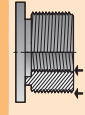

page B78-B93

# Parting off Modular system (MSS)

FX / LX



page B4-B5

FX / LX



page B6-B7

GX



page B8-B9

GX



page B10-B11

Clamp block  
and blade



page B12-B13

FX mono



page B14

GMS



page B15

## shank 0°

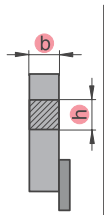

drawing illustrates right hand execution

details: page D2

## shank 90°

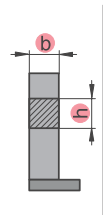

drawing illustrates right hand execution

details: page D3

Bgr.	[inch]		type, ordering description
	h	b	
E20	.625	.787	R MSS-E20R00-10-E MSS-E20R00-12-E
	.750	.750	
	.625	.787	L MSS-E20L00-10-E MSS-E20L00-12-E
	.750	.750	
E25	1.000	1.000	R MSS-E25R00-16-E
	1.000	1.000	L MSS-E25L00-16-E
	1.000	1.000	R MSS-E25R90-16-E
E32	1.250	1.000	R MSS-E32R00-85-E MSS-E32R00-20-E
	1.250	1.250	
	1.250	1.000	L MSS-E32L00-85-E MSS-E32L00-20-E
	1.250	1.250	
	1.250	1.000	R MSS-E32R90-85-E MSS-E32R90-20-E
	1.250	1.250	

Bgr.	[inch]		type, ordering description
	h	b	
E20	.750	.750	L MSS-E20L90-12-E
	.750	.750	R MSS-E20R90-12-E
	1.000	1.000	L MSS-E25L90-16-E
	1.000	1.000	R MSS-E25R90-16-E
E32	1.250	1.000	L MSS-E32L90-85-E MSS-E32L90-20-E
	1.250	1.250	
	1.250	1.000	R MSS-E32R90-85-E MSS-E32R90-20-E
	1.250	1.250	

Bgr. = assembly size

ordering example: 1 piece MSS-E25R00-16-E  
2 pieces MSS-E25R25-FX4.1



attention in case of 90°:

right hand shank – left module  
left hand shank – right module

# FX / LX system

## short FX module

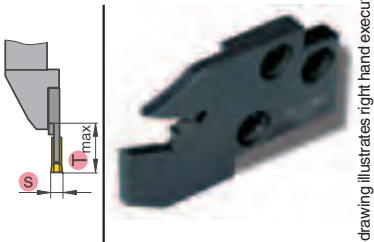

drawing illustrates right hand execution

details: page D10

[inch]		type, ordering description
s	T <sub>max</sub>	
.087	.79	MSS-E20R20-FX2.2
.122		MSS-E20R20-FX3.1
.161		R MSS-E20R20-FX4.1
.087	.79	MSS-E20L20-FX2.2
.122		MSS-E20L20-FX3.1
.161		L MSS-E20L20-FX4.1
.087	.79	MSS-E25R20-FX2.2
.122		MSS-E25R25-FX3.1
.161		R MSS-E25R25-FX4.1
.201		MSS-E25R25-FX5.1
.256		MSS-E25R25-FX6.5
.087	.98	MSS-E25L20-FX2.2
.122		MSS-E25L25-FX3.1
.161		L MSS-E25L25-FX4.1
.201		MSS-E25L25-FX5.1
.256		MSS-E25L25-FX6.5
.122	1.26	MSS-E32R32-FX3.1
.161		MSS-E32R32-FX4.1
.201		R MSS-E32R32-FX5.1
.256		MSS-E32R32-FX6.5
.256		MSS-E32R32-FX6.5
.122	1.26	MSS-E32L32-FX3.1
.161		MSS-E32L32-FX4.1
.201		L MSS-E32L32-FX5.1
.256		MSS-E32L32-FX6.5
.256		MSS-E32L32-FX6.5



FX



details: page C2 - C6

## long FX module

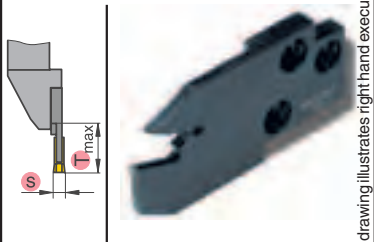

drawing illustrates right hand execution

details: page D11

[inch]		type, ordering description
s	T <sub>max</sub>	
.122	1.38	MSS-E25R35-FX3.1
.161		R MSS-E25R35-FX4.1
.201		MSS-E25R35-FX5.1
.256		MSS-E25R35-FX6.5
.256		MSS-E25R35-FX6.5
.122	1.38	MSS-E25L35-FX3.1
.161		L MSS-E25L35-FX4.1
.201		MSS-E25L35-FX5.1
.256		MSS-E25L35-FX6.5
.256		MSS-E25L35-FX6.5
.122	1.77	MSS-E32R45-FX3.1
.161		MSS-E32R45-FX4.1
.201		R MSS-E32R45-FX5.1
.256		MSS-E32R45-FX6.5
.256		MSS-E32R45-FX6.5
.122	1.77	MSS-E32L45-FX3.1
.161		MSS-E32L45-FX4.1
.201		L MSS-E32L45-FX5.1
.256		MSS-E32L45-FX6.5
.256		MSS-E32L45-FX6.5



FX



details: page C2 - C6

## module LX

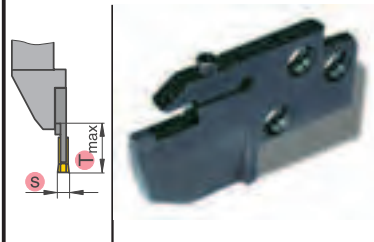

details: page D21

[inch]		type, ordering description
s	T <sub>max</sub>	
.315	1.26	MSS-E32N25-LX
.315		MSS-E32N32-LX
.315		N MSS-E32N45-LX
.315	1.77	MSS-E32N25-LX
.315		MSS-E32N32-LX
.315		N MSS-E32N45-LX



LX E



details: page C7

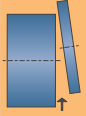

page B2-B15

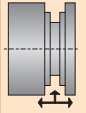

page B16-B23

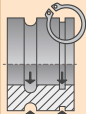

page B24-B49

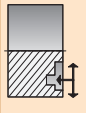

page B50-B59

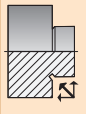

page B60-B65

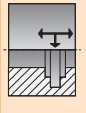

page B66-B77

### Turning

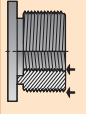

page B78-B93

### Milling

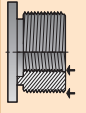

page B94-B99



# Parting off

FX / LX



page B4-B5

FX / LX



page B6-B7

GX



page B8-B9

GX



page B10-B11

Clamp block and blade



page B12-B13

FX mono



page B14

GMS



page B15

## UTS 0°

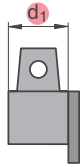

drawing illustrates right hand execution

details: page D36

## UTS 90°

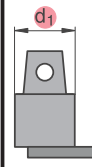

drawing illustrates right hand execution

details: page D37

Bgr.	[mm]	type, ordering description
	d <sub>1</sub>	
E25	40	UT40-MSS-E25R00
	50	UT50-MSS-E25R00
	63	<b>R</b> UT63-MSS-E25R00
	40	UT40-MSS-E25L00
	50	UT50-MSS-E25L00
	63	<b>L</b> UT63-MSS-E25L00
E32	50	UT50-MSS-E32R00
	63	UT63-MSS-E32R00
	50	UT50-MSS-E32L00
	63	UT63-MSS-E32L00

Bgr.	[mm]	type, ordering description
	d <sub>1</sub>	
E25	40	UT40-MSS-E25L90
	50	UT50-MSS-E25L90
	63	<b>L</b>
	40	UT40-MSS-E25R90
	50	UT50-MSS-E25R90
	63	<b>R</b>
E32	63	UT63-MSS-E32L90
	63	UT63-MSS-E32R90

Bgr. = assembly size

**ordering example:** 1 piece UT40-MSS-E25L00  
2 pieces MSS-E25L25-FX4.1



**attention in case of 90°:**

right hand shank UTS holder – left module  
left hand UTS holder – right module

# FX / LX system

## short FX module

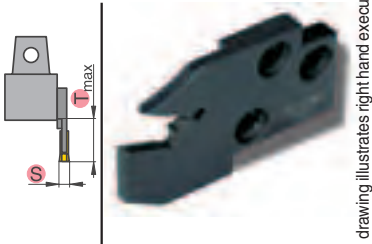

drawing illustrates right hand execution

details: page D10

[inch]		type, ordering description
s	T <sub>max</sub>	
.087	.79	MSS-E25R20-FX2.2
.122	.98	MSS-E25R25-FX3.1
.161		R MSS-E25R25-FX4.1
.201		MSS-E25R25-FX5.1
.256		MSS-E25R25-FX6.5
.087	.79	MSS-E25L20-FX2.2
.122	.98	MSS-E25L25-FX3.1
.161		L MSS-E25L25-FX4.1
.201		MSS-E25L25-FX5.1
.256		MSS-E25L25-FX6.5
.122	1.26	MSS-E32R32-FX3.1
.161		MSS-E32R32-FX4.1
.201		R MSS-E32R32-FX5.1
.256		MSS-E32R32-FX6.5
.122	1.26	MSS-E32L32-FX3.1
.161		MSS-E32L32-FX4.1
.201		L MSS-E32L32-FX5.1
.256		MSS-E32L32-FX6.5



FX



details: page C2 - C5

## long FX module

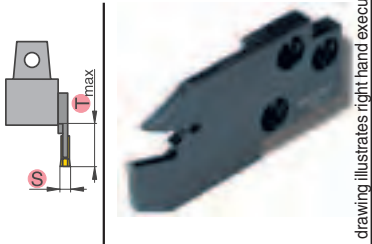

drawing illustrates right hand execution

details: page D11

[inch]		type, ordering description
s	T <sub>max</sub>	
.122	1.38	MSS-E25R35-FX3.1
.161		MSS-E25R35-FX4.1
.201		R MSS-E25R35-FX5.1
.256		MSS-E25R35-FX6.5
.122	1.38	MSS-E25L35-FX3.1
.161		MSS-E25L35-FX4.1
.201		L MSS-E25L35-FX5.1
.256		MSS-E25L35-FX6.5
.122	1.77	MSS-E32R45-FX3.1
.161		MSS-E32R45-FX4.1
.201		R MSS-E32R45-FX5.1
.256		MSS-E32R45-FX6.5
.122	1.77	MSS-E32L45-FX3.1
.161		MSS-E32L45-FX4.1
.201		L MSS-E32L45-FX5.1
.256		MSS-E32L45-FX6.5



FX



details: page C3 - C5

## module LX

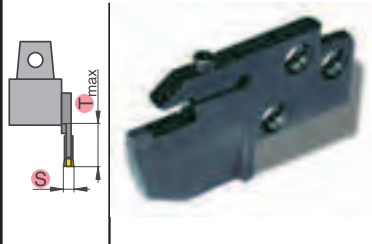

details: page D21

[inch]		type, ordering description
s	T <sub>max</sub>	
.315	.98	MSS-E32N25-LX
.315	1.26	MSS-E32N32-LX
	1.77	N MSS-E32N45-LX
.315	.98	MSS-E32N25-LX
	1.26	MSS-E32N32-LX
	1.77	N MSS-E32N45-LX



LX E



details: page C7

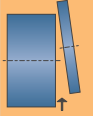

page B2-B15

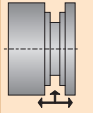

page B16-B23

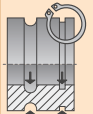

page B24-B49

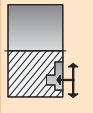

page B50-B59

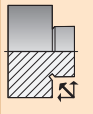

page B60-B65

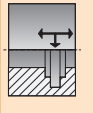

page B66-B77

### Turning

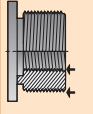

page B78-B93

### Milling

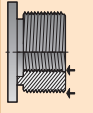

page B94-B99

# Parting off Modular system (MSS)

FX / LX



page B4-B5

FX / LX



page B6-B7

GX



page B8-B9

GX



page B10-B11

Clamp block  
and blade



page B12-B13

FX mono



page B14

GMS



page B15

shank 0°

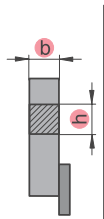

drawing illustrates right hand execution

details: page D2

shank 90°

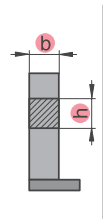

drawing illustrates right hand execution

details: page D3

Bgr.	[inch]		type, ordering description
	h	b	
E20	.625	.787	R MSS-E20R00-10-E MSS-E20R00-12-E
	.750	.750	
	.625	.787	L MSS-E20L00-10-E MSS-E20L00-12-E
	.750	.750	
E25	1.000	1.000	R MSS-E25R00-16-E
	1.000	1.000	
	1.000	1.000	L MSS-E25L00-16-E
	1.000	1.000	
E32	1.250	1.000	R MSS-E32R00-85-E MSS-E32R00-20-E
	1.250	1.250	
	1.250	.984	L MSS-E32L00-85-E MSS-E32L00-20-E
	1.250	1.250	

h	b	type, ordering description
.750	.750	L MSS-E20L90-12-E
.750	.750	R MSS-E20R90-12-E
1.000	1.000	L MSS-E25L90-16-E
1.000	1.000	R MSS-E25R90-16-E
1.250	1.000	L MSS-E32L90-85-E MSS-E32L90-20-E
1.250	1.000	R MSS-E32R90-85-E MSS-E32R90-20-E

Bgr. = assembly size

ordering example: 1 piece MSS-E25R00-16-E  
2 pieces MSS-E25R12-GX16-2



attention in case of 90°:

right hand shank – left module  
left hand shank – right module

# GX system

## module GX16

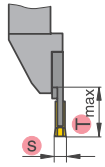

drawing illustrates right hand execution

details: page D15

[inch]		type, ordering description
s	T <sub>max</sub>	
.079 - .108	.47	MSS-E20R12-GX16-1
.109 - .148		MSS-E20R12-GX16-2
.148 - .197		<b>R</b> MSS-E20R12-GX16-3
.079 - .108	.47	MSS-E20L12-GX16-1
.109 - .148		MSS-E20L12-GX16-2
.148 - .197		<b>L</b> MSS-E20L12-GX16-3
.079 - .108	.47	MSS-E25R12-GX16-1
.109 - .148		MSS-E25R12-GX16-2
.148 - .197		<b>R</b> MSS-E25R12-GX16-3
.197 - .256		MSS-E25R12-GX16-4
.079 - .108	.47	MSS-E25L12-GX16-1
.109 - .148		MSS-E25L12-GX16-2
.148 - .197		<b>L</b> MSS-E25L12-GX16-3
.197 - .256		MSS-E25L12-GX16-4
.109 - .148	.47	MSS-E32R12-GX16-2
.148 - .197		MSS-E32R12-GX16-3
.197 - .256		<b>R</b> MSS-E32R12-GX16-4
.109 - .148	.47	MSS-E32L12-GX16-2
.148 - .197		MSS-E32L12-GX16-3
.197 - .256		<b>L</b> MSS-E32L12-GX16-4



## GX16

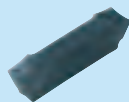

details: page C9 - C10

## module GX24

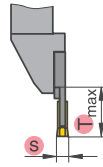

drawing illustrates right hand execution

details: page D16

[inch]		type, ordering description
s	T <sub>max</sub>	
.109 - .148	.83	MSS-E20R21-GX24-2
.148 - .197		<b>R</b> MSS-E20R21-GX24-3
.109 - .148	.83	MSS-E20L21-GX24-2
.148 - .197		<b>L</b> MSS-E20L21-GX24-3
.109 - .148	.83	MSS-E25R21-GX24-2
.148 - .197		MSS-E25R21-GX24-3
.197 - .256		<b>R</b> MSS-E25R21-GX24-4
.109 - .148		MSS-E25L21-GX24-2
.148 - .197	MSS-E25L21-GX24-3	
.197 - .256	<b>L</b> MSS-E25L21-GX24-4	
.109 - .148	.83	MSS-E32R21-GX24-2
.148 - .197		MSS-E32R21-GX24-3
.197 - .256		<b>R</b> MSS-E32R21-GX24-4
.109 - .148	.83	MSS-E32L21-GX24-2
.148 - .197		MSS-E32L21-GX24-3
.197 - .256		<b>L</b> MSS-E32L21-GX24-4



## GX24



details: page C11

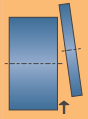

page B2-B15

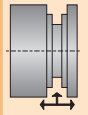

page B16-B23

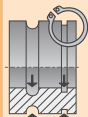

page B24-B49

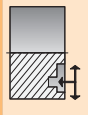

page B50-B59

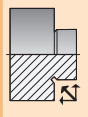

page B60-B65

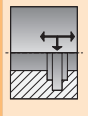

page B66-B77

### Turning

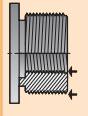

page B78-B93

### Milling

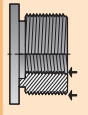

page B94-B99



# Parting off UTS (MSS)

FX / LX



page B4-B5

FX / LX



page B6-B7

GX



page B8-B9

GX



page B10-B11

Clamp block  
and blade



page B12-B13

FX mono



page B14

GMS



page B15

## UTS 0°

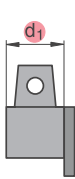

drawing illustrates right hand execution

details: page D36

Bgr.	[mm]	type, ordering description
	d <sub>1</sub>	
E25	40	UT40-MSS-E25R00
	50	UT50-MSS-E25R00
	63	R UT63-MSS-E25R00
	40	UT40-MSS-E25L00
	50	UT50-MSS-E25L00
	63	L UT63-MSS-E25L00
E32	50	UT50-MSS-E32R00
	63	R UT63-MSS-E32R00
	50	UT50-MSS-E32L00
	63	L UT63-MSS-E32L00

## UTS 90°

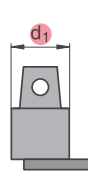

drawing illustrates right hand execution

details: page D37

Bgr.	[mm]	type, ordering description
	d <sub>1</sub>	
E25	40	UT40-MSS-E25L90
	50	UT50-MSS-E25L90
	63	L UT63-MSS-E25L90
	40	UT40-MSS-E25R90
	50	UT50-MSS-E25R90
	63	R UT63-MSS-E25R90
E32	63	UT63-MSS-E32L90
	63	L UT63-MSS-E32L90
	63	UT63-MSS-E32R90
	63	R UT63-MSS-E32R90

Bgr. = assembly size

ordering example: 1 piece UT40-MSS-E25L00  
2 pieces MSS-E25L21-GX24-3



attention in case of 90°:

right hand shank UTS holder – left module  
left hand UTS holder – right module

# GX system GX

## module GX16

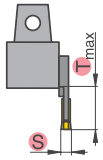

drawing illustrates righthand execution

details: page D15

[inch]		type, ordering description
s	T <sub>max</sub>	
.079 - .108	.47	MSS-E25R12-GX16-1
.109 - .148		MSS-E25R12-GX16-2
.148 - .197		<b>R</b> MSS-E25R12-GX16-3
.197 - .256		MSS-E25R12-GX16-4
.079 - .108	.47	MSS-E25L12-GX16-1
.109 - .148		MSS-E25L12-GX16-2
.148 - .197		<b>L</b> MSS-E25L12-GX16-3
.197 - .256		MSS-E25L12-GX16-4
.109 - .148	.47	MSS-E32R12-GX16-2
.148 - .197		MSS-E32R12-GX16-3
.197 - .256		<b>R</b> MSS-E32R12-GX16-4
.109 - .148	.47	MSS-E32L12-GX16-2
.148 - .197		MSS-E32L12-GX16-3
.197 - .256		<b>L</b> MSS-E32L12-GX16-4



## GX16



details: page C9 - C10

## module GX24

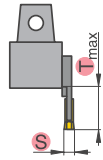

drawing illustrates righthand execution

details: page D16

[inch]		type, ordering description
s	T <sub>max</sub>	
.109 - .148	.83	MSS-E25R21-GX24-2
.148 - .197		MSS-E25R21-GX24-3
.197 - .256		<b>R</b> MSS-E25R21-GX24-4
.109 - .148	.83	MSS-E25L21-GX24-2
.148 - .197		MSS-E25L21-GX24-3
.197 - .256		<b>L</b> MSS-E25L21-GX24-4
.109 - .148	.83	MSS-E32R21-GX24-2
.148 - .197		MSS-E32R21-GX24-3
.197 - .256		<b>R</b> MSS-E32R21-GX24-4
.109 - .148	.83	MSS-E32L21-GX24-2
.148 - .197		MSS-E32L21-GX24-3
.197 - .256		<b>L</b> MSS-E32L21-GX24-4



## GX24



details: page C11

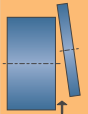

page B2-B15

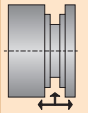

page B16-B23

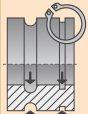

page B24-B49

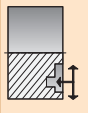

page B50-B59

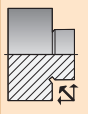

page B60-B65

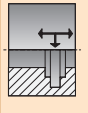

page B66-B77

### Turning

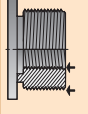

page B78-B93

### Milling

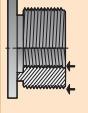

page B94-B99

# Parting off

## Clamp block and blade

FX / LX



page B4-B5

FX / LX



page B6-B7

GX



page B8-B9

GX



page B10-B11

Clamp block and blade



page B12-B13

FX mono



page B14

GMS



page B15

### clamp block

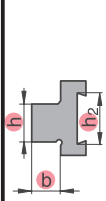

details: page D44

h <sub>2</sub>	[inch]		type, ordering description
	h	b	
1.024	.750	.700	SBN 12-26K-E
1.260	1.000	.950	SBN 16-32K-E
	1.250	1.200	SBN 20-32K-E
1.811	1.250	1.200	SBN 20-46K-E
	1.500	1.450	SBN 24-46K-E

### split clampblock

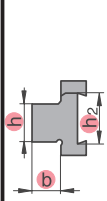

details: page D45

[inch]		type, ordering description
h	b	
.750	.700	SBN 12-26KS-E
1.000	.950	SBN 16-32KS-E
1.250	1.200	SBN 20-32KS-E

ordering example: 1 piece SBN 20-32K-E  
2 pieces XLCFN 3204 M41 FX

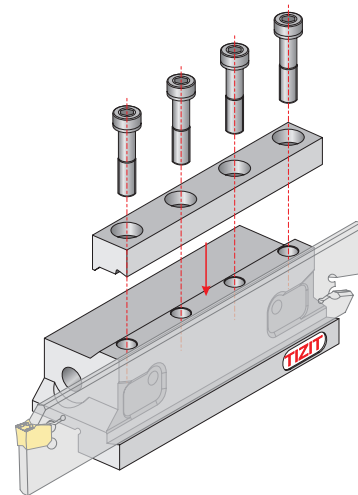

### split clamp block

For wedge clamp systems or restricted areas.

# FX / GX24 / LX system

## blade FX

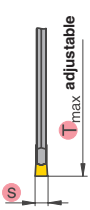

details: page D41

## blade GX24

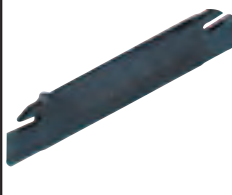
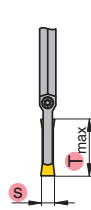

details: page D42

## blade LX

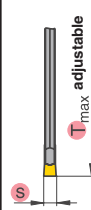

details: page D43

[inch]		type, ordering description
s	T <sub>max</sub>	
.087	.98	XLCEN 2602 J22 FX
.122	1.38	XLCFN 2603 J31 FX
.161	1.57	XLCFN 2604 J41 FX
.087	1.18	XLCEN 3202 M22 FX
.122	1.97	XLCFN 3203 M31 FX
.161		XLCFN 3204 M41 FX
.201	2.16	XLCFN 3205 M51 FX
.256		XLCFN 3206 M65 FX
.323	3.15	XLCEN 4608 S82 FX
.382		XLCEN 4609 S97 FX



[inch]		type, ordering description
s	T <sub>max</sub>	
.109-.148	.83	XLCFN 3203-GX24-2S
.148-.197		XLCFN 3204-GX24-3S
.197-.256		XLCFN 3206-GX24-4S



[inch]		type, ordering description
s	T <sub>max</sub>	
.315	3.15	XLCEN 4608 LX



**FX**

details: page C2 - C6

**GX24**

details: page C11

**LX E**

details: page C7

page B2-B15

page B16-B23

page B24-B49

page B50-B59

page B60-B65

page B66-B77

**Turning**

page B78-B93

**Milling**

page B94-B99

# Parting off Monobloc tool FX

FX / LX



page B4-B5

FX / LX



page B6-B7

GX



page B8-B9

GX



page B10-B11

Clamp block  
and blade



page B12-B13

FX mono



page B14

GMS



page B15

## monobloc holder 0°

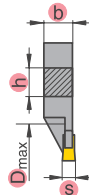

drawing illustrates right hand execution

details: page D8 - D9

[inch]					type, ordering description
s	h	b	D <sub>max</sub>		
.087	.375	.375	1.18	R	XLCER 06 M22 FX-E
	.500	.500			XLCER 08 F22 FX-E
	.500	.500			XLCER 08 M22 FX-E
	.563	.563			XLCER 09 M22 FX-E
	.625	.625			XLCER 10 H22 FX-E
.122	.625	.625	1.18		XLCFR 10 H31 FX-E
	.750	.750	1.57		XLCFR 12 K31 FX-E
	1.000	.750	1.97		XLCFR 64 M31 FX-E
.161	.750	.750	1.57		XLCFR 12 K41 FX-E
	1.000	.750	1.97		XLCFR 64 M41 FX-E
.087	.375	.375	1.18	L	XLCEL 06 M22 FX-E
	.500	.500			XLCEL 08 F22 FX-E
	.500	.500			XLCEL 08 M22 FX-E
	.563	.563			XLCEL 09 M22 FX-E
	.625	.625			XLCEL 10 H22 FX-E
.122	.625	.625	1.18		XLCFL 10 H31 FX-E
	.750	.750	1.57		XLCFL 12 K31 FX-E
	1.000	.750	1.97		XLCFL 64 M31 FX-E
.161	.750	.750	1.57		XLCFL 12 K41 FX-E
	1.000	.750	1.97		XLCFL 64 M41 FX-E



ordering example: 1 piece XLCFR 64 M41 FX-E

FX



details: page C2 - C6



# Parting off GMS system

## GMS - monobloc holder 0°

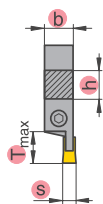

drawing illustrates right hand execution

details: page D7

[inch]				type, ordering description
h	b	s	T <sub>max</sub>	
.630	.472	.118	.55	CLCDR 1612 K30 R
.630	.472	.118	.55	CLCDL 1612 K30 L



ordering example: 1 piece CLCDR 1612 K30

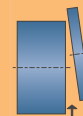

page B2-B15

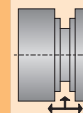

page B16-B23

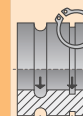

page B24-B49

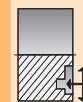

page B50-B59



page B60-B65

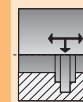

page B66-B77

### Turning

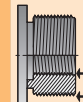

page B78-B93

### Milling

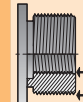

page B94-B99

**GMS-insert** (= Goldmaster coated HSS parting insert)



details: page C23

# Grooving and turning (external) Overview

GX09



page B18-B19

GX / LX



page B20-B21

GX / LX



page B22-B23

	<p><b>monobloc holder 0°</b></p> <p><b>h / b</b> .375/.375</p> <p><b>s</b> = .079 - .148</p> <p><b>T<sub>max</sub></b> = .27</p>
	<p><b>shank 0°</b></p> <p><b>h / b</b> .625/.787 - 1.250/1.250</p>
	<p><b>UTS 0°</b></p> <p><b>d<sub>1</sub></b> 40 - 63 mm</p>

	<p><b>shank 0°</b></p> <p><b>h / b</b> .500/.500 - .625/.625</p>
	<p><b>shank 90°</b></p> <p><b>h / b</b> .750/.750 - 1.250/1.250</p>
	<p><b>UTS 90°</b></p> <p><b>d<sub>1</sub></b> 40 - 63 mm</p>

	<p><b>module GX09</b></p> <p><math>s = .079 - .148</math> <math>T_{max} = .27</math></p>
	<p><b>module GX16</b></p> <p><math>s = .079 - .256</math> <math>T_{max} = .47</math></p>
	<p><b>module GX16</b></p> <p><math>s = .079 - .256</math> <math>T_{max} = .47</math></p>

	<p><b>module GX24</b></p> <p><math>s = .118 - .315</math> <math>T_{max} = .83</math></p>
	<p><b>module GX24</b></p> <p><math>s = .118 - .315</math> <math>T_{max} = .83</math></p>

	<p><b>module LX</b></p> <p><math>s = .315</math> <math>T_{max} = .98 - 1.77</math></p>
	<p><b>module LX</b></p> <p><math>s = .315</math> <math>T_{max} = .98 - 1.77</math></p>

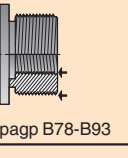
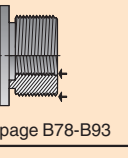
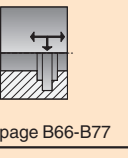
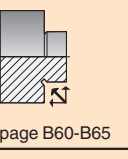
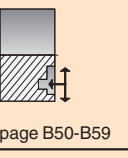
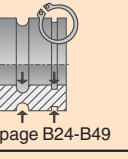
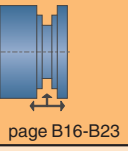
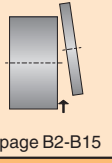

# Grooving and turning (external)

## Monobloc tool      Modular system (MSS)

GX09



page B18-B19

GX / LX



page B20-B21

GX / LX



page B22-B23

### monobloc holder 0°

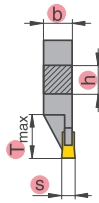

drawing illustrates right hand execution

details: page D6

### shank 0°

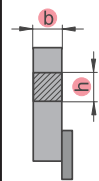

drawing illustrates right hand execution

details: page D2

Bgr.	[inch]				type, ordering description
	h	b	s	T <sub>max</sub>	
E10	.375	.375	.77 - .138	.27	E10R00-06-E R
	.375	.375	.77 - .138	.27	E10L00-06-E L

Bgr.	[inch]		type, ordering description
	h	b	
E12	.500	.500	MSS-E12R00-08-E R
	.500	.500	MSS-E12L00-08-E L
E16	.625	.625	MSS-E16R00-10-E R
	.625	.625	MSS-E16L00-10-E L



Bgr. = assembly size

**ordering example:**

- 1 piece MSS-E12R00-08-E
- 2 pieces MSS-E12R07-GX09-2

GX09

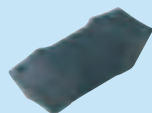

details: page C8

GX09R



details: page C12



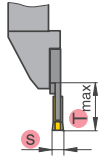

# System GX09

## module GX09



drawing illustrates right hand execution

details: page D14

[inch]		type, ordering description	
s	T <sub>max</sub>		
.079 - .108 .109 - .148	.27		MSS-E12R07-GX09-1 MSS-E12R07-GX09-2 <b>R</b>
.079 - .108 .109 - .148	.27		MSS-E12L07-GX09-1 MSS-E12L07-GX09-2 <b>L</b>
.079 - .108 .109 - .148	.27		MSS-E16R07-GX09-1 MSS-E16R07-GX09-2 <b>R</b>
.079 - .108 .109 - .148	.27		MSS-E16L07-GX09-1 MSS-E16L07-GX09-2 <b>L</b>



**GX09**

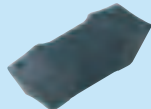

details: page C8

**GX09R**



details: page C12

**Application**

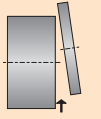

page B2-B15

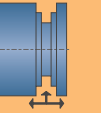

page B16-B23

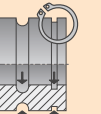

page B24-B49

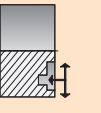

page B50-B59

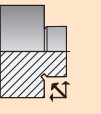

page B60-B65

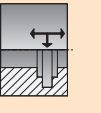

page B66-B77

**Turning**

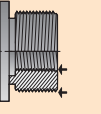

page B78-B93

**Milling**

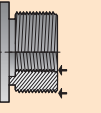

page B94-B99



# Grooving and turning (external)

## Modular system (MSS)

GX



page B18-B19

GX / LX



page B20-B21

GX / LX



page B22-B23

### shank 0°

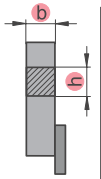

drawing illustrates right hand execution

details: page D2

### shank 90°

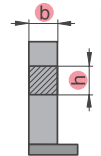

drawing illustrates right hand execution

details: page D3

Bgr.	[inch]		type, ordering description
	h	b	
E20	.625	.787	R MSS-E20R00-10-E MSS-E20R00-12-E
	.750	.750	
	.625	.787	L MSS-E20L00-10-E MSS-E20L00-12-E
	.750	.750	
E25	1.000	1.000	R MSS-E25R00-16-E
	1.000	1.000	
	1.000	1.000	L MSS-E25L00-16-E
	1.000	1.000	
E32	1.250	1.000	R MSS-E32R00-85-E MSS-E32R00-20-E
	1.250	1.250	
	1.250	1.000	L MSS-E32L00-85-E MSS-E32L00-20-E
	1.250	1.250	

h	b	type, ordering description
.750	.750	L MSS-E20L90-12-E
.750	.750	R MSS-E20R90-12-E
1.000	1.000	L MSS-E25L90-16-E
1.000	1.000	R MSS-E25R90-16-E
1.250	1.000	L MSS-E32L90-85-E MSS-E32L90-20-E
1.250	1.250	R MSS-E32R90-85-E MSS-E32R90-20-E

Bgr. = assembly size

**ordering example:** 1 piece MSS-E20L00-12-E  
2 pieces MSS-E20L21-GX24-2





attention in case of 90°:

right hand shank – left module  
left hand shank – right module

# GX16 / GX24 / LX system

Application

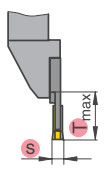
### module GX16

drawing illustrates right hand execution

details: page D15

[inch]		type, ordering description
s	T <sub>max</sub>	
.079 - .108	.47	MSS-E20R12-GX16-1
.109 - .148		MSS-E20R12-GX16-2
.148 - .197		<b>R</b> MSS-E20R12-GX16-3
.079 - .108	.47	MSS-E20L12-GX16-1
.109 - .148		MSS-E20L12-GX16-2
.148 - .197		<b>L</b> MSS-E20L12-GX16-3
.079 - .108	.47	MSS-E25R12-GX16-1
.109 - .148		MSS-E25R12-GX16-2
.148 - .197		<b>R</b> MSS-E25R12-GX16-3
.197 - .256		MSS-E25R12-GX16-4
.079 - .108	.47	MSS-E25L12-GX16-1
.109 - .148		MSS-E25L12-GX16-2
.148 - .197		<b>L</b> MSS-E25L12-GX16-3
.197 - .256		MSS-E25L12-GX16-4
.109 - .148	.47	MSS-E32R12-GX16-2
.148 - .197		MSS-E32R12-GX16-3
.197 - .256		<b>R</b> MSS-E32R12-GX16-4
.109 - .148	.47	MSS-E32L12-GX16-2
.148 - .197		MSS-E32L12-GX16-3
.197 - .256		<b>L</b> MSS-E32L12-GX16-4



**GX16**





page C9 - C10

**GX16R**

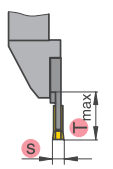

page C13

### module GX24

drawing illustrates right hand execution

details: page D16

[inch]		type, ordering description
s	T <sub>max</sub>	
.109 - .148	.83	MSS-E20R21-GX24-2
.148 - .197		<b>R</b> MSS-E20R21-GX24-3
.109 - .148	.83	MSS-E20L21-GX24-2
.148 - .197		<b>L</b> MSS-E20L21-GX24-3
.109 - .148	.83	MSS-E25R21-GX24-2
.148 - .197		MSS-E25R21-GX24-3
.197 - .256		<b>R</b> MSS-E25R21-GX24-4
.315		MSS-E25R21-GX24-5
.109 - .148	.83	MSS-E25L21-GX24-2
.148 - .197		MSS-E25L21-GX24-3
.197 - .256		<b>L</b> MSS-E25L21-GX24-4
.315		MSS-E25L21-GX24-5
.109 - .148	.83	MSS-E32R21-GX24-2
.148 - .197		MSS-E32R21-GX24-3
.197 - .256	<b>R</b> MSS-E32R21-GX24-4	
.109 - .148	.83	MSS-E32L21-GX24-2
.148 - .197		MSS-E32L21-GX24-3
.197 - .256	<b>L</b> MSS-E32L21-GX24-4	



**GX24E**





page C11

**GX24R**

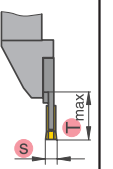

page C14

### module LX

drawing illustrates right hand execution

details: page D21

[inch]		type, ordering description
s	T <sub>max</sub>	
.315	.98	MSS-E32N25-LX
	1.26	MSS-E32N32-LX
	1.77	<b>N</b> MSS-E32N45-LX
.315	.98	MSS-E32N25-LX
	1.26	MSS-E32N32-LX
	1.77	<b>N</b> MSS-E32N45-LX



**LX E**



page C7

**LX R**



page C7

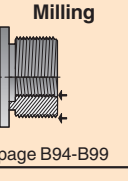
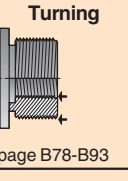
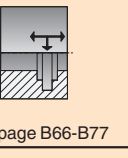
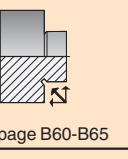
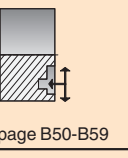
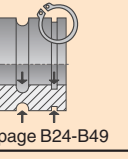
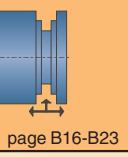
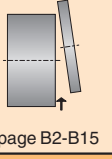

# Grooving and turning (external) UTS (MSS)

GX



page B18-B19

GX / LX



page B20-B21

GX / LX



page B22-B23

## UTS 0°

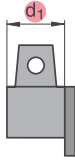

drawing illustrates right hand execution

details: page D36

## UTS 90°

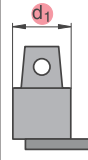

drawing illustrates right hand execution

details: page D37

Bgr.	[mm]	type, ordering description
	d <sub>1</sub>	
E25	40	UT40-MSS-E25R00
	50	UT50-MSS-E25R00
	63	<b>R</b> UT63-MSS-E25R00
	40	UT40-MSS-E25L00
	50	UT50-MSS-E25L00
	63	<b>L</b> UT63-MSS-E25L00
E32	50	UT50-MSS-E32R00
	63	UT63-MSS-E32R00
		<b>R</b>
	50	UT50-MSS-E32L00
	63	UT63-MSS-E32L00
		<b>L</b>

Bgr.	[mm]	type, ordering description
	d <sub>1</sub>	
E25	40	UT40-MSS-E25L90
	50	UT50-MSS-E25L90
		<b>L</b>
	40	UT40-MSS-E25R90
	50	UT50-MSS-E25R90
		<b>R</b>
E32	63	UT63-MSS-E32L90
		<b>L</b>
	63	UT63-MSS-E32R90
		<b>R</b>

Bgr. = assembly size

**ordering example:** 1 piece UT50-MSS-E25R90  
2 pieces MSS-E25L12-GX16-2





**attention in case of 90°:**

right hand shank UTS holder – left module  
left hand UTS holder – right module

# GX16 / GX24 / LX system

Application

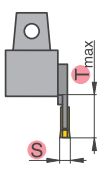
### module GX16





drawing illustrates right hand execution

details: page D15

[inch]		type, ordering description
s	T <sub>max</sub>	
.079 - .108	.47	MSS-E25R12-GX16-1
.109 - .148		MSS-E25R12-GX16-2
.148 - .197		<b>R</b> MSS-E25R12-GX16-3
.197 - .256		MSS-E25R12-GX16-4
.079 - .108	.47	MSS-E25L12-GX16-1
.109 - .148		MSS-E25L12-GX16-2
.148 - .197		<b>L</b> MSS-E25L12-GX16-3
.197 - .256		MSS-E25L12-GX16-4
.109 - .148	.47	MSS-E32R12-GX16-2
.148 - .197		MSS-E32R12-GX16-3
.197 - .256		<b>R</b> MSS-E32R12-GX16-4
.109 - .148	.47	MSS-E32L12-GX16-2
.148 - .197		MSS-E32L12-GX16-3
.197 - .256		<b>L</b> MSS-E32L12-GX16-4

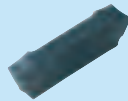
**GX16**





page C9 - C10

**GX16R**

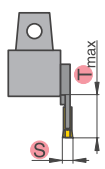

page C13

### module GX24





drawing illustrates right hand execution

details: page D16

[inch]		type, ordering description
s	T <sub>max</sub>	
.109 - .148	.83	MSS-E25R21-GX24-2
.148 - .197		MSS-E25R21-GX24-3
.197 - .256		<b>R</b> MSS-E25R21-GX24-4
.315		MSS-E25R21-GX24-5
.109 - .148		MSS-E25L21-GX24-2
.148 - .197	MSS-E25L21-GX24-3	
.197 - .256	<b>L</b> MSS-E25L21-GX24-4	
.315	MSS-E25L21-GX24-5	
.109 - .148	.83	MSS-E32R21-GX24-2
.148 - .197		MSS-E32R21-GX24-3
.197 - .256		<b>R</b> MSS-E32R21-GX24-4
.109 - .148	.83	MSS-E32L21-GX24-2
.148 - .197		MSS-E32L21-GX24-3
.197 - .256		<b>L</b> MSS-E32L21-GX24-4

**GX24E**





page C11

**GX24R**

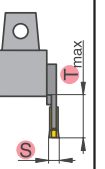

page C14

### module LX





drawing illustrates right hand execution

details: page D21

[inch]		type, ordering description
s	T <sub>max</sub>	
.315	.98	MSS-E32N25-LX
.315	1.26	MSS-E32N32-LX
.315	1.77	<b>N</b> MSS-E32N45-LX
.315	.98	MSS-E32N25-LX
.315	1.26	MSS-E32N32-LX
.315	1.77	<b>N</b> MSS-E32N45-LX

**LX E**



page C7

**LX R**



page C7

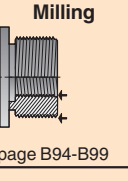
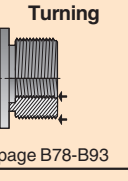
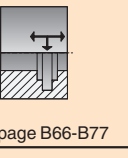
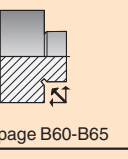
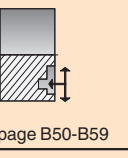
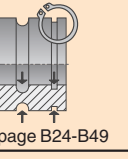
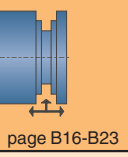
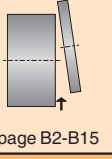

# Circlip and O-ring grooves

## Overview

GX09...



page B27

**monobloc holder 0°**

**h / b**  $s = .024 - .128$   
 $.375/.375$   $T_{max} = .029 - .27$

GX ...



page B28-B33

**shank 0°**

**h / b**  
 $.500/.500 - 1.250/1.250$

**shank 90°**



**h / b**  
 $.750/.750 - 1.250/1.250$

GX ...



page B34-B35

**UTS 0°**

**d<sub>1</sub>**  
 40 - 63 mm

**UTS 90°**

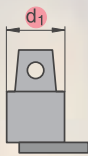

**d<sub>1</sub>**  
 40 - 63 mm

GX09



page B37

**monobloc boring bar**

**D<sub>min</sub> = .63**  $s = .024 - .128$   
 $l_2 = 1.18$   $d_1 = .625$   $T_{max} = .029 - .118$

GX...



page B38-B43

**boring bar 1.5D**

**d<sub>1</sub> = .750 - 1.500**  
 $l_2 = .94 - 2.36$

**boring bar 2.5D**

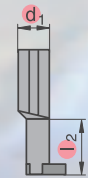

**d<sub>1</sub> = .750 - 2.000**  
 $l_2 = 1.57 - 3.94$

GX...



page B44-B49

**UTS boring bar**

**d<sub>1</sub> = 40 - 63 mm**  
 $l_2 = 1.26 - 3.15$



	<p><b>module GX09</b></p> <p><math>s = .024 - .128</math> <math>T_{max} = .029 - .27</math></p>		<p><b>module GX16</b></p> <p><math>s = .024 - .207</math> <math>T_{max} = .029 - .47</math></p>
			<p><b>module GX16</b></p> <p><math>s = .024 - .207</math> <math>T_{max} = .029 - .47</math></p>
	<p><b>module GX09</b></p> <p><math>s = .024 - .128</math> <math>T_{max} = .029 - 2.36</math> <math>D_{min} = .79 - 1.26</math></p>		<p><b>module GX16</b></p> <p><math>s = .024 - .207</math> <math>T_{max} = .029 - .39</math> <math>D_{min} = 1.57 - 1.97</math></p>
	<p><b>module GX09</b></p> <p><math>s = .024 - .128</math> <math>T_{max} = .029 - 2.36</math> <math>D_{min} = .79 - 1.26</math></p>		<p><b>module GX16</b></p> <p><math>s = .024 - .207</math> <math>T_{max} = .029 - .39</math> <math>D_{min} = 1.57 - 1.97</math></p>

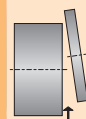

page B2-B15

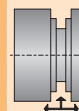

page B16-B23



page B24-B49

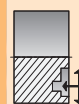

page B50-B59



page B60-B65

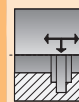

page B66-B77

**Turning**

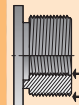

page B78-B93

**Milling**

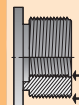

pagp B78-B93

# System

**GX09...**



page B27

**GX...**



page B28-B33

**GX...**



page B34-B35

**GX09**



page B37

**GX..**



page B38-B43

**GX...**



page B44-B49

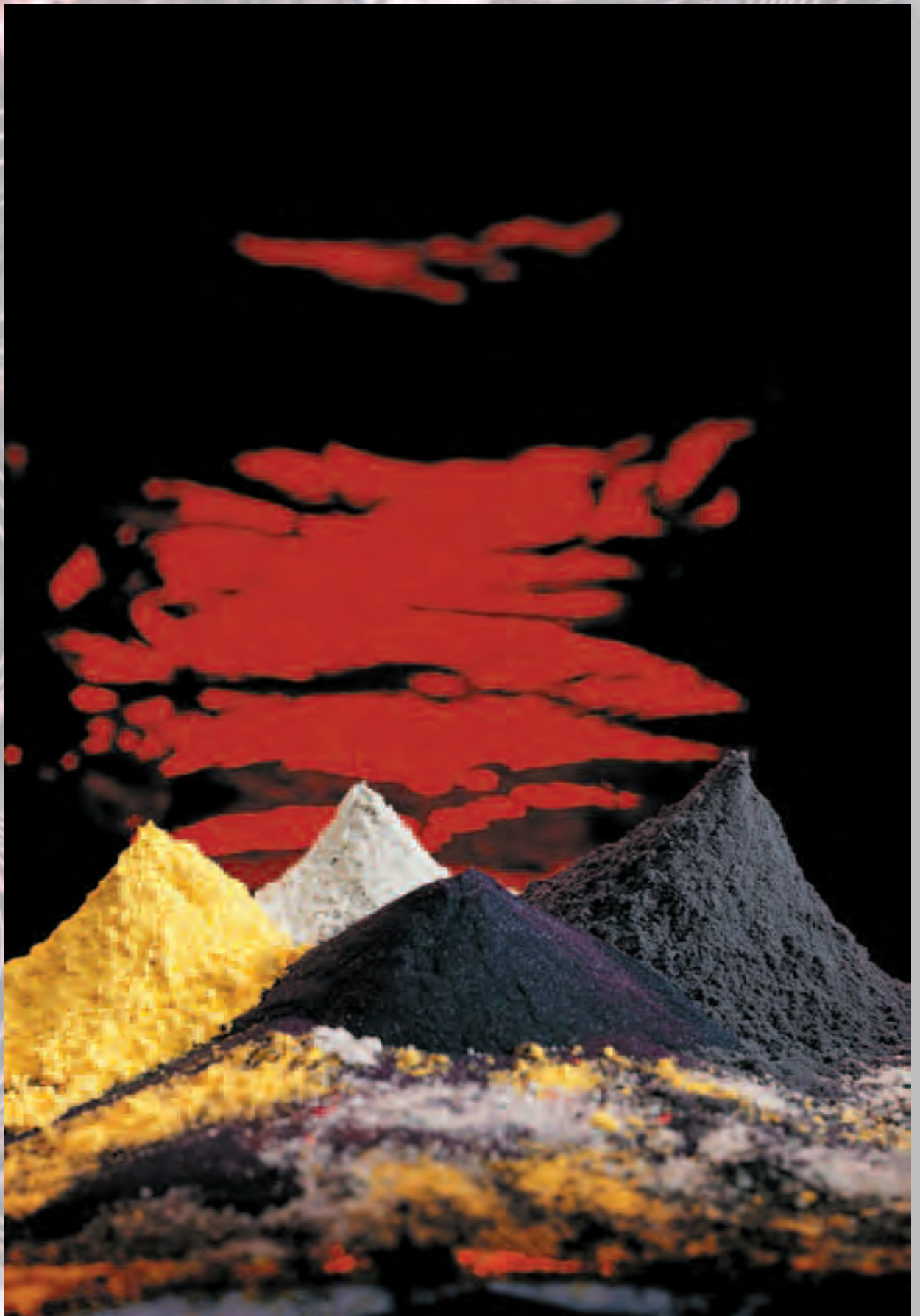

# Circlip and O-ring grooves (external)

## Modular system (MSS)

Application

**monobloc holder 0°**

drawing illustrates righthand execution

details: page D6

Bgr.	[inch]						type, ordering description	
	h	b	s	T <sub>max</sub>	r	T <sub>max</sub>		
E10	.375	.375	.024	.029	.031	.070	E10R00-06-E R	
			.031	.037				
			.035	.041				
			.039	.045				
			.047	.053				
			.055	.060				
			.067	.072				
			.077	.27	.039	.27		
	.088	.27	.047	.27				
	.108	.27						
	.128	.27						
	.375	.375	.024	.029	.031	.070		E10L00-06-E L
			.031	.037				
			.035	.041				
			.039	.045				
			.047	.053				
.055			.060					
.067			.072					
.077			.27	.039	.27			
.088	.27	.047	.27					
.108	.27							
.128	.27							

Bgr. = assembly size

ordering example: 1 piece E10R00-06-E



**attention:** When using rh or lh insert, the insert support seat requires modification to prevent damage to insert.

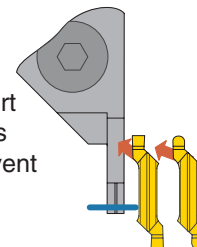

**GX09-1S...R/L**



details: page C16

**GX09-.S...N**



details: page C17

**GX09-1R...R/L**



details: page C20

**GX09-.R...N**



details: page C20

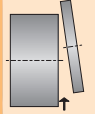

page B2-B15

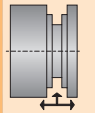

page B16-B23



page B24-B49

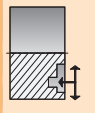

page B50-B59

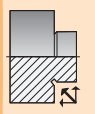

page B60-B65

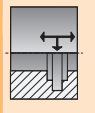

page B66-B77

**Turning**

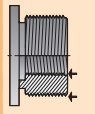

page B78-B93

**Milling**

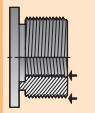

page B94-B99

# Circlip and O-ring grooves (external)

## Modular system (MSS)

GX09...



page B27

GX...



page B28-B33

GX...



page B34-B35

GX09



page B37

GX..



page B38-B43

GX...





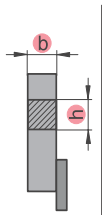

page B44-B49

shank 0°



drawing illustrates right hand execution

details: page D2

Bgr.	[inch]		type, ordering description
	h	b	
E12	.500	.500	 MSS-E12R00-08-E R
	.500	.500	 MSS-E12L00-08-E L
E16	.625	.625	 MSS-E16R00-10-E R
	.625	.625	 MSS-E16L00-10-E L

Bgr. = assembly size

**ordering example:** 1 piece MSS-E16L00-10-E  
2 pieces MSS-E16L02-GX09-1

# GX09 system

## module GX09

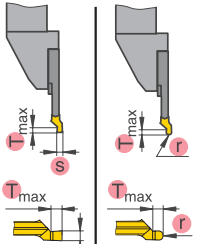

drawing illustrates right hand execution

details: page D12

s	T <sub>max</sub>	r	T <sub>max</sub>	type, ordering description
.024	.029	.031	.070	MSS-E12R02-GX09-1
.031	.037			R
.035	.041			
.039	.045			
.047	.053			
.055	.060			
.067	.072			
.024	.029	.031	.070	
.031	.037			L
.035	.041			
.039	.045			
.047	.053			
.055	.060			
.067	.072			

.024	.029	.031	.070	MSS-E16R02-GX09-1
.031	.037			R
.035	.041			
.039	.045			
.047	.053			
.055	.060			
.067	.072			
.024	.029	.031	.070	
.031	.037			L
.035	.041			
.039	.045			
.047	.053			
.055	.060			
.067	.072			



**GX09-1S...R/L**



details: page C16

**GX09-1R...R/L**



details: page C20

## module GX09

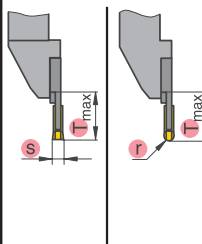

drawing illustrates right hand execution

details: page D14

s	T <sub>max</sub>	r	T <sub>max</sub>	type, ordering description
.077	.088	.039	.27	MSS-E12R07-GX09-1
.108	.128	.047		R
.108	.128			
.108	.128			
.108	.128			
.108	.128			MSS-E12R07-GX09-2
.077	.088	.039	.27	MSS-E12L07-GX09-1
.108	.128	.047		L
.108	.128			
.108	.128			
.108	.128			
.108	.128			MSS-E12L07-GX09-2

.077	.088	.039	.27	MSS-E16R07-GX09-1
.108	.128	.047		R
.108	.128			
.108	.128			
.108	.128			
.108	.128			MSS-E16R07-GX09-2
.077	.088	.039	.27	MSS-E16L07-GX09-1
.108	.128	.047		L
.108	.128			
.108	.128			
.108	.128			
.108	.128			MSS-E16L07-GX09-2



**GX09-.S...N**

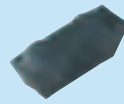

details: page C17

**GX09-.R...N**



details: page C20

Application

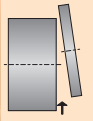

page B2-B15

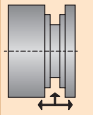

page B16-B23

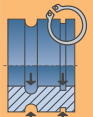

page B24-B49

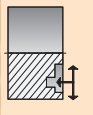

page B50-B59

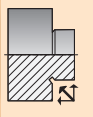

page B60-B65

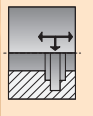

page B66-B77

**Turning**

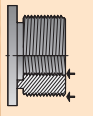

page B78-B93

**Milling**

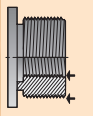

page B78-B93



# Circlip and O-ring grooves (external)

## Modular system (MSS)

GX09...



page B27

GX...



page B28-B33

GX...



page B34-B35

GX09



page B37

GX..



page B38-B43

GX...



page B44-B49

### shank 0°

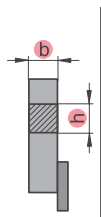

drawing illustrates right hand execution



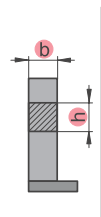

details: page D2





### shank 90°



drawing illustrates right hand execution

details: page D3

Bgr.	[inch]		type, ordering description
	h	b	
E20	.625	.787	 MSS-E20R00-10-E MSS-E20R00-12-E
	.750	.750	
E20	.625	.787	 MSS-E20L00-10-E MSS-E20L00-12-E
	.750	.750	
E25	1.000	1.000	 MSS-E25R00-16-E
	1.000	1.000	
E25	1.000	1.000	 MSS-E25L00-16-E
	1.000	1.000	

Bgr.	[inch]		type, ordering description
	h	b	
E20	.750	.750	 MSS-E20L90-12-E
	.750	.750	
E20	.750	.750	 MSS-E20R90-12-E
	.750	.750	
E25	1.000	1.000	 MSS-E25L90-16-E
	1.000	1.000	
E25	1.000	1.000	 MSS-E25R90-16-E
	1.000	1.000	

Bgr. = assembly size

**ordering example:** 1 piece MSS-E25R00-16-E  
2 pieces MSS-E25R12-GX16-3



attention in case of 90°:

right hand shank – left module  
left hand shank – right module

# GX16 system

## module GX16

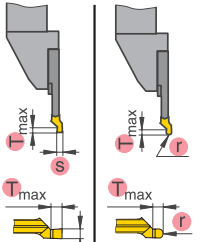

drawing illustrates right hand execution

details: page D13

s	T <sub>max</sub>	r	T <sub>max</sub>	type, ordering description
.024	.029	.031	.070	MSS-E20R03-GX16-2 R
.031	.037	.039	.086	
.035	.041	.047	.101	
.039	.045			
.047	.053			
.055	.060			
.067	.072			
.077	.081			
.088	.093			
.024	.029	.031	.070	MSS-E20L03-GX16-2 L
↓	↓	.039	.086	
.088	.093	.047	.101	

.024	.029	.031	.070	MSS-E25R03-GX16-2 R
↓	↓	.039	.086	
.088	.093	.047	.101	

.024	.029	.031	.070	MSS-E25L03-GX16-2 L
↓	↓	.039	.086	
.088	.093	.047	.101	

**GX16-2S...R/L**

details: page C18

**GX16-2R...R/L**

details: page C21

## module GX16

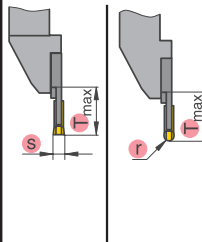

drawing illustrates right hand execution

details: page D15

s	T <sub>max</sub>	r	T <sub>max</sub>	type, ordering description
.108	.128	.059	.47	MSS-E20R12-GX16-2 R
.167	.207			
.167	.207	.079	.47	
.207		.098		
.167	.207	.079	.47	MSS-E20R12-GX16-3
.207		.098		
.108	.128	.059	.47	MSS-E20L12-GX16-2 L
.167	.207			
.167	.207	.079	.47	
.207		.098		
.167	.207	.079	.47	MSS-E20L12-GX16-3
.207		.098		

.108	.128	.059	.47	MSS-E25R12-GX16-2 R
.167	.207			
.167	.207	.079	.47	
.207	.47	.118	.47	MSS-E25R12-GX16-4

.108	.128	.059	.47	MSS-E25L12-GX16-2 L
.167	.207			
.167	.207	.079	.47	
.207	.47	.118	.47	
.167	.207	.079	.47	MSS-E25L12-GX16-3
.207		.098		
.207	.47	.118	.47	MSS-E25L12-GX16-4

**GX16-S...N**

details: page C19

**GX16-R...N**

details: page C21

## Application

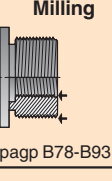
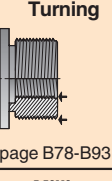
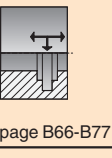
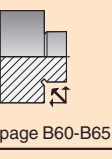
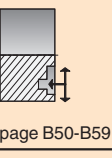
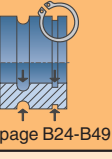
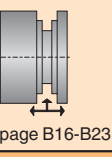
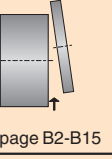

# Circlip and O-ring grooves (external)

## Modular system (MSS)

GX09...



page B27

GX...



page B28-B33

GX...



page B34-B35

GX09



page B37

GX..



page B38-B43

GX...



page B44-B49

### shank 0°

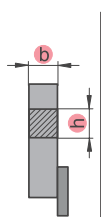

drawing illustrates right hand execution



details: page D2

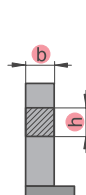

### shank 90°



drawing illustrates right hand execution

details: page D3

Bgr.	[inch]		type, ordering description
	h	b	
	1.250	1.000	 MSS-E32R00-85-E MSS-E32R00-20-E
	1.250	1.250	
E32	1.250	1.000	 MSS-E32L00-85-E MSS-E32L00-20-E
	1.250	1.250	

Bgr.	[inch]		type, ordering description
	h	b	
	1.250	1.000	 MSS-E32L90-85-E MSS-E32L90-20-E
	1.250	1.250	
E32	1.250	1.000	 MSS-E32R90-85-E MSS-E32R90-20-E
	1.250	1.250	

Bgr. = assembly size

**ordering example:** 1 piece MSS-E32R00-85-E  
2 pieces MSS-E32R03-GX16-2



**attention in case of 90°:**

right hand shank – left module  
left hand shank – right module

# GX16 system

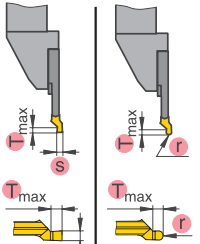

## Application

### module GX16



drawing illustrates right hand execution

details: page D13

s	T <sub>max</sub>	r	T <sub>max</sub>	type, ordering description
.024	.029	.031	.070	 MSS-E32R03-GX16-2 R
.031	.037	.039	.086	
.035	.041	.047	.101	
.039	.045			
.047	.053			
.055	.060			
.067	.072			
.077	.081			
.088	.093			
.024	.029	.031	.070	 MSS-E32L03-GX16-2 L
.031	.037	.039	.086	
.035	.041	.047	.101	
.039	.045			
.047	.053			
.055	.060			
.067	.072			
.077	.081			
.088	.093			



**GX16-2S...R/L**



details: page C18

**GX16-2R...R/L**



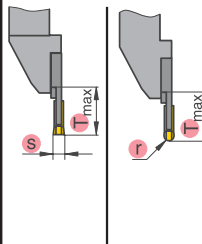

details: page C21

### module GX16



drawing illustrates right hand execution

details: page D15

s	T <sub>max</sub>	r	T <sub>max</sub>	type, ordering description
.108	.128	.059	.47	 MSS-E32R12-GX16-2 R
.167	.207			
.167	.207	.079	.47	
.207	.207	.098	.47	
.207	.47	.118	.47	MSS-E32R12-GX16-4
.108	.128	.059	.47	 MSS-E32L12-GX16-2 L
.167	.207			
.167	.207	.079	.47	
.207	.207	.098	.47	
.207	.47	.118	.47	MSS-E32L12-GX16-4



**GX16-.S...N**

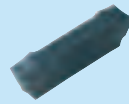

details: page C19

**GX16-.R...N**



details: page C21

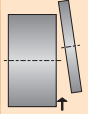

page B2-B15

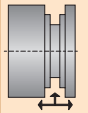

page B16-B23

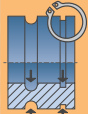

page B24-B49

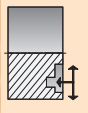

page B50-B59

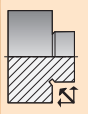

page B60-B65

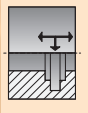

page B66-B77

### Turning

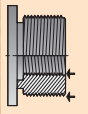

page B78-B93

### Milling

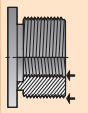

page B78-B93

# Circlip and O-ring grooves (external) UTS (MSS)

GX09...



page B27

GX...



page B28-B33

GX...



page B34-B35

GX09



page B37

GX..



page B38-B43

GX...



page B44-B49

## UTS 0°

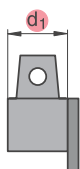

drawing illustrates right hand execution

details: page D36

## UTS 90°

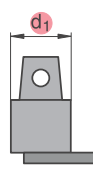

drawing illustrates right hand execution

details: page D37

Bgr.	[mm] d <sub>1</sub>	type, ordering description
E25	40	UT40-MSS-E25R00
	50	UT50-MSS-E25R00
	63	<b>R</b> UT63-MSS-E25R00
	40	UT40-MSS-E25L00
	50	UT50-MSS-E25L00
	63	<b>L</b> UT63-MSS-E25L00
E32	50	UT50-MSS-E32R00
	63	UT63-MSS-E32R00 <b>R</b>
	50	UT50-MSS-E32L00
	63	UT63-MSS-E32L00 <b>L</b>

Bgr.	[mm] d <sub>1</sub>	type, ordering description
	40	UT40-MSS-E25L90
	50	UT50-MSS-E25L90 <b>L</b>
	40	UT40-MSS-E25R90
	50	UT50-MSS-E25R90 <b>R</b>
	63	UT63-MSS-E32L90 <b>L</b>
	63	UT63-MSS-E32R90 <b>R</b>

Bgr. = assembly size

**ordering example:** 1 piece UT50-MSS-E25L00  
2 pieces MSS-E20L03-GX16-2



attention in case of 90°:

right hand shank UTS holder – left module  
left hand UTS holder – right module



# GX16 system

Application

**module GX16**

drawing illustrates right hand execution

**details: page D13**

**module GX16**

drawing illustrates right hand execution

**details: page D15**

s	T <sub>max</sub>	r	T <sub>max</sub>	type, ordering description
.024	.029	.031	.086	MSS-E25R03-GX16-2  R
.031	.037	.039	.101	
.035	.041	.047		
.039	.045			
.047	.053			
.055	.060			
.067	.072			
.077	.081			
.088	.093		.070	
.024	.029	.031	.086	MSS-E25L03-GX16-2  L
↓	↓	.039	.101	
.088	.093	.047		
			.070	
.024	.029	.031	.086	MSS-E32R03-GX16-2  R
↓	↓	.039	.101	
.088	.093	.047		
			.070	
.024	.029	.031	.086	MSS-E32L03-GX16-2  L
↓	↓	.039	.101	
.088	.093	.047		
			.070	

**GX16-2S...R/L**

details: page C18

**GX16-2R...R/L**

details: page C21

s	T <sub>max</sub>	r	T <sub>max</sub>	type, ordering description
.108	.128	.059	.47	MSS-E25R12-GX16-2  R
.167	.47			
.207				
.207				
.167	.47	.079	.47	MSS-E25R12-GX16-3
.207	.47	.118	.47	MSS-E25R12-GX16-4
.108	.128	.059	.47	MSS-E25L12-GX16-2  L
.167	.47			
.207				
.207				
.167	.47	.079	.47	MSS-E25L12-GX16-3
.207	.47	.118	.47	MSS-E25L12-GX16-4
.108	.128	.059	.47	MSS-E32R12-GX16-2  R
.167	.47			
.207				
.207				
.167	.47	.079	.47	MSS-E32R12-GX16-3
.207	.47	.118	.47	MSS-E32R12-GX16-4
.108	.128	.059	.47	MSS-E32L12-GX16-2  L
.167	.47			
.207				
.207				
.167	.47	.079	.47	MSS-E32L12-GX16-3
.207	.47	.118	.47	MSS-E32L12-GX16-4

**GX16-S...N**

details: page C19

**GX16-R...N**

details: page C21

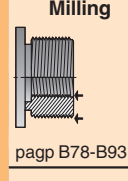
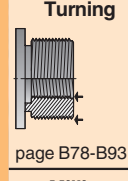
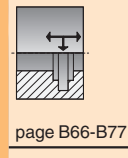
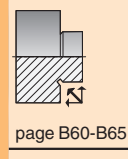
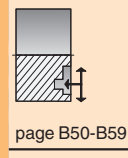
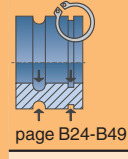
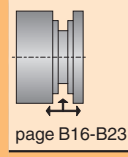
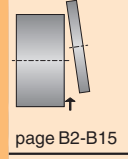

# System

GX09...



page B27

GX...



page B28-B33

GX...



page B34-B35

GX09



page B37

GX..



page B38-B43

GX...



page B44-B49



# Circlip and O-ring grooves (internal)

## Modular system (MSS)

Application

### monobloc boring bar

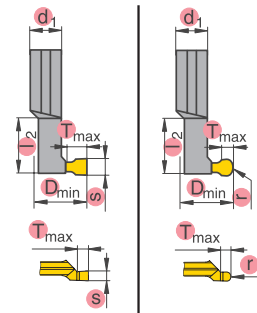

drawing illustrates right hand execution

details: page D23

Bgr.	[inch]							type, ordering description	
	D <sub>min</sub>	l <sub>2</sub>	d <sub>1</sub>	s	T <sub>max</sub>	r	T <sub>max</sub>		
112	.63	1.18	.625	.024	.029	.031	.070	I12R90-2.5D-GX09-E R	
				.031	.037				
				.035	.041				
				.039	.045				
				.047	.053				
				.055	.060				
				.067	.072				
				.077	.118				
				.088	.118				
	.108	.118							
	.128	.118							
	.63	1.18	.625	.024	.029	.031	.070		I12L90-2.5D-GX09-E L
				.031	.037				
				.035	.041				
				.039	.045				
				.047	.053				
				.055	.060				
				.067	.072				
				.077	.118				
.088				.118					
.108	.118								
.128	.118								

Bgr. = assembly size

**ordering example:**  
1 piece I12R90-2.5D-GX09-E



**attention:** When using rh or lh insert, the insert support seat requires modification to prevent damage to insert.

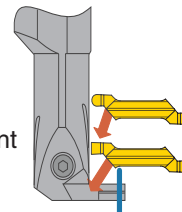

**GX09-1S...R/L**



details: page C16

**GX09-.S...N**



details: page C17

**GX09-1R...R/L**



details: page C20

**GX09-.R...N**



details: page C20

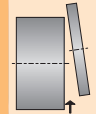

page B2-B15

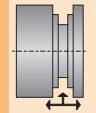

page B16-B23

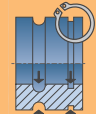

page B24-B49

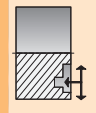

page B50-B59

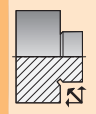

page B60-B65

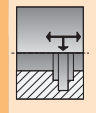

page B66-B77

#### Turning

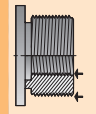

page B78-B93

#### Milling

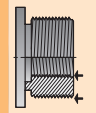

page B94-B99

# Circlip and O-ring grooves (internal)

## Modular system (MSS)

GX09...



page B27

GX...



page B28-B33

GX...



page B34-B35

GX09



page B37

GX...



page B38-B43

GX...



page B44-B49

### boring bar 1.5D

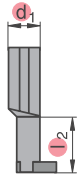

drawing illustrates right hand execution



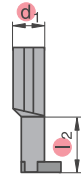

details: page D24





### boring bar 2.5D



drawing illustrates right hand execution

details: page D25

Bgr.	[inch]		type, ordering description
	l <sub>2</sub>	d <sub>1</sub>	
I16	.94	.750	 MSS-I16R90-1.5D-E
	.94	.750	 MSS-I16L90-1.5D-E
I20	1.18	.750	 MSS-I20R90-1.5D-E
	1.18	.750	 MSS-I20L90-1.5D-E

Bgr.	[inch]		type, ordering description
	l <sub>2</sub>	d <sub>1</sub>	
I16	1.57	.750	 MSS-I16R90-2.5D-E
	1.57	.750	 MSS-I16L90-2.5D-E
I20	1.97	1.000	 MSS-I20R90-2.5D-E
	1.97	1.000	 MSS-I20L90-2.5D-E

Bgr. = assembly size

**ordering example:** 1 piece MSS-I20R90-2.5D-E  
2 pieces MSS-I20R02-GX09-1

# GX09 system

## module GX09

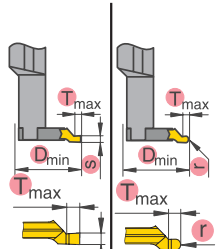

drawing illustrates right hand execution

details: page D26

## module GX09

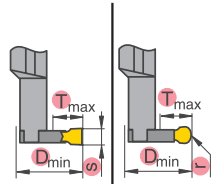

drawing illustrates right hand execution

details: page D28

[inch]					type, ordering description
D <sub>min</sub>	s	T <sub>max</sub>	r	T <sub>max</sub>	
.79	.024	.029	.031	.070	MSS-I16R02-GX09-1
	.031	.037			R
	.035	.041			
	.039	.045			
	.047	.053			
	.055	.060			
	.067	.072			
.79	.024	.029	.031	.070	MSS-I16L02-GX09-1
	↓	↓			L
	.067	.072			

.98	.024	.029	.031	.070	MSS-I20R02-GX09-1
	↓	↓			R
	.067	.072			

.98	.024	.029	.031	.070	MSS-I20L02-GX09-1
	↓	↓			L
	.067	.072			



**GX09-1S...R/L**



details: page C16

**GX09-1R...R/L**



details: page C20

[inch]					type, ordering description
D <sub>min</sub>	s	T <sub>max</sub>	r	T <sub>max</sub>	
.79	.077	.039	.039	.157	MSS-I16R04-GX09-1
	.088	.047			R
	.108	.157			
	.108				MSS-I16R04-GX09-2
	.128	.157			
.79	.077	.039	.039	.157	MSS-I16L04-GX09-1
	.088	.047			L
	.108	.157			
	.108				MSS-I16L04-GX09-2
	.128	.157			

.98	.077	.039	.039	.197	MSS-I20R05-GX09-1
	.088	.047			R
	.108	.197			
	.108				MSS-I20R05-GX09-2
	.128	.197			

.98	.077	.039	.039	.197	MSS-I20L05-GX09-1
	.088	.047			L
	.108	.197			
	.108				MSS-I20L05-GX09-2
.128	.197				



**GX09-.S...N**

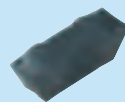

details: page C17

**GX09-.R...N**



details: page C20

Application

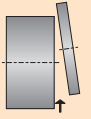

page B2-B15

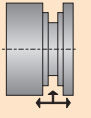

page B16-B23

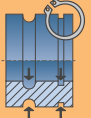

page B24-B49

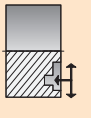

page B50-B59

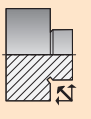

page B60-B65

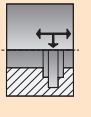

page B66-B77

**Turning**

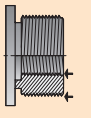

page B78-B93

**Milling**

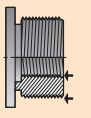

page B78-B93



# Circlip and O-ring grooves (internal)

## Modular system (MSS)

System

GX09...



page B27

GX...



page B28-B33

GX...



page B34-B35

GX09



page B37

GX...



page B38-B43

GX...



page B44-B49

### boring bar 1.5D

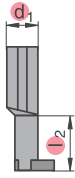

drawing illustrates right hand execution



details: page D24

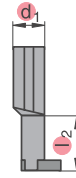

### boring bar 2.5D



drawing illustrates right hand execution

details: page D25

Bgr.	[inch]		type, ordering description
	l <sub>2</sub>	d <sub>1</sub>	
I25	1.50	1.000	 MSS-I25R90-1.5D-E R
	1.50	1.000	 MSS-I25L90-1.5D-E L

Bgr.	[inch]		type, ordering description
	l <sub>2</sub>	d <sub>1</sub>	
I25	2.48	1.250	 MSS-I25R90-2.5D-E R
	2.48	1.250	 MSS-I25L90-2.5D-E L

Bgr. = assembly size

**ordering example:** 1 piece MSS-I25R90-2.5D-E  
2 pieces MSS-I25R02-GX09-1

# GX09 system

## module GX09

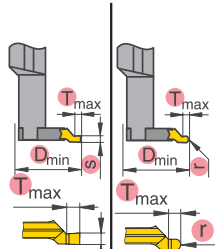

drawing illustrates right hand execution

details: page D26

## module GX09

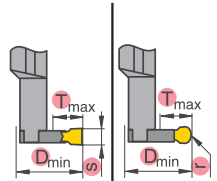

drawing illustrates right hand execution

details: page D28

[inch]					type, ordering description
D <sub>min</sub>	s	T <sub>max</sub>	r	T <sub>max</sub>	
1.26	.024	.029	.031	.070	MSS-I25R02-GX09-1
	.031	.037			R
	.035	.041			
	.039	.045			
	.047	.053			
	.055	.060			
	.067	.072			
1.26	.024	.029	.031	.070	MSS-I25L02-GX09-1
	↓	↓			L
	.067	.072			



[inch]					type, ordering description
D <sub>min</sub>	s	T <sub>max</sub>	r	T <sub>max</sub>	
1.26	.077	.039	.039	.236	MSS-I25R06-GX09-1
	.088	.236	.047		R
	.108				
	.128				
1.26	.108	.236			MSS-I25R06-GX09-2
	.128				
	.077	.039	.039	.236	MSS-I25L06-GX09-1
	.088	.236	.047		L
.108					
.128	.236			MSS-I25L06-GX09-2	



GX09-1S...R/L



details: page C16

GX09-1R...R/L



details: page C20

GX09-.S...N

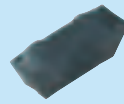

details: page C17

GX09-.R...N



details: page C20

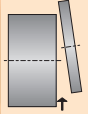

page B2-B15

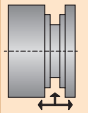

page B16-B23

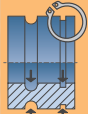

page B24-B49

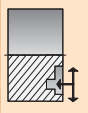

page B50-B59

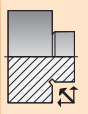

page B60-B65

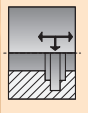

page B66-B77

### Turning

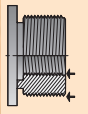

page B78-B93

### Milling

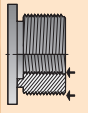

page B78-B93

# Circlip and O-ring grooves (internal)

## Modular system (MSS)

GX09...



page B27

GX...



page B28-B33

GX...



page B34-B35

GX09



page B37

GX..



page B38-B43

GX...



page B44-B49

### boring bar 1.5D

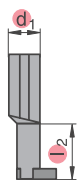

drawing illustrates right hand execution

details: page D24

### boring bar 2.5D

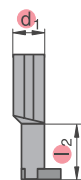

drawing illustrates right hand execution

details: page D25

Bgr.	[inch]		type, ordering description
	l <sub>2</sub>	d <sub>1</sub>	
I32	1.89	1.250	MSS-I32R90-1.5D-E R
	1.89	1.250	MSS-I32L90-1.5D-E L
I40	2.36	1.500	MSS-I40R90-1.5D-E R
	2.36	1.500	MSS-I40L90-1.5D-E L

Bgr.	[inch]		type, ordering description
	l <sub>2</sub>	d <sub>1</sub>	
I32	3.15	1.500	MSS-I32R90-2.5D-E R
	3.15	1.500	MSS-I32L90-2.5D-E L
I40	3.94	2.000	MSS-I40R90-2.5D-E R
	3.94	2.000	MSS-I40L90-2.5D-E L

Bgr. = assembly size

**ordering example:** 1 piece MSS-I32L90-2.5D-E  
2 pieces MSS-I40R03-GX16-2

# GX16 system

## module GX16

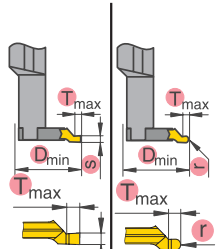

drawing illustrates right hand execution

details: page D27

## module GX16

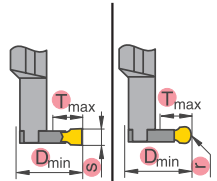

drawing illustrates right hand execution

details: page D29

[inch]					type, ordering description
D <sub>min</sub>	s	T <sub>max</sub>	r	T <sub>max</sub>	
1.57	.024	.029	.031	.070	MSS-I32R03-GX16-2
	.031	.037	.039	.086	R
	.035	.041	.047	.101	
	.039	.045			
	.047	.053			
	.055	.060			
	.067	.072			
	.077	.081			
1.57	.024	.029	.031	.070	MSS-I32L03-GX16-2
	↓	↓	.039	.086	L
	.088	.093	.047	.101	

1.97	.024	.029	.031	.070	MSS-I40R03-GX16-2
	↓	↓	.039	.086	R
	.088	.093	.047	.101	

1.97	.024	.029	.031	.070	MSS-I40L03-GX16-2
	↓	↓	.039	.086	L
	.088	.093	.047	.101	

**GX16-2S...R/L**



details: page C18

**GX16-2R...R/L**



details: page C21

[inch]					type, ordering description
D <sub>min</sub>	s	T <sub>max</sub>	r	T <sub>max</sub>	
1.57	.108		.059	.354	MSS-I32R09-GX16-2
	.128				R
	.167	.354			
	.207				
	.167	.354	.079	.354	MSS-I32R09-GX16-3
	.207		.098		R
	.207	.354	.118	.354	
	1.57	.108		.059	.354
.128		.354			L
.167					
.207			.079	.354	MSS-I32L09-GX16-3
.207		.354	.098	.354	MSS-I32L09-GX16-4

1.97	.108		.059	.394	MSS-I40R10-GX16-2
	.128	.394			R
	.167		.079	.394	
	.207	.394	.098	.394	
1.97	.167	.394	.118	.394	MSS-I40R10-GX16-3
	.207	.394	.118	.394	MSS-I40R10-GX16-4
	.108		.059	.394	MSS-I40L10-GX16-2
	.128	.394			L
.167					
1.97	.207		.079	.394	MSS-I40L10-GX16-3
	.207	.394	.098	.394	L
	.207	.394	.118	.394	

**GX16-S...N**



details: page C19

**GX16-R...N**



details: page C21

## Application

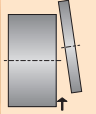

page B2-B15

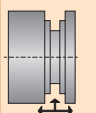

page B16-B23

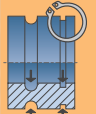

page B24-B49

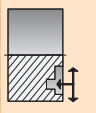

page B50-B59

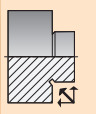

page B60-B65

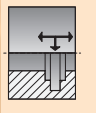

page B66-B77

### Turning

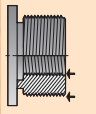

page B78-B93

### Milling

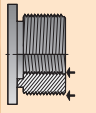

page B78-B93

# Circlip and O-ring grooves (internal) UTS (MSS)

System

GX09...



page B27

GX...



page B28-B33

GX...



page B34-B35

GX09



page B37

GX..



page B38-B43

GX...





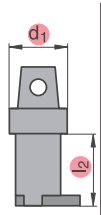

page B44-B49

## UTS - boring bar



drawing illustrates right hand execution

details: page D39

Bgr.	[inch]	[mm]	type, ordering description
	l <sub>2</sub>	d <sub>1</sub>	
I16	1.26	40	 UT40-MSS-I16R90-2D R
	1.26	40	 UT40-MSS-I16L90-2D L
I20	1.57	40	 UT40-MSS-I20R90-2D R
	1.57	40	 UT40-MSS-I20L90-2D L

Bgr. = assembly size

ordering example: 1 piece UT50-MSS-I16L90-2D  
2 pieces MSS-I16L04-GX09-1



# GX09 system

## module GX09

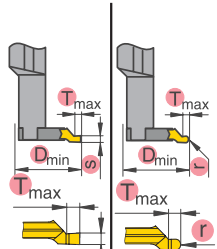

drawing illustrates right hand execution

details: page D26

## module GX09

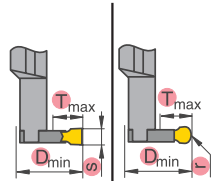

drawing illustrates right hand execution

details: page D28

[inch]					type, ordering description
D <sub>min</sub>	s	T <sub>max</sub>	r	T <sub>max</sub>	
.79	.024	.029	.031	.070	MSS-I16R02-GX09-1
	.031	.037			R
	.035	.041			
	.039	.045			
	.047	.053			
	.055	.060			
	.067	.072			
.79	.024	.029	.031	.070	MSS-I16L02-GX09-1
	↓	↓			L
	.067	.072			

.98	.024	.029	.031	.070	MSS-I20R02-GX09-1
	↓	↓			R
	.067	.072			

.98	.024	.029	.031	.070	MSS-I20L02-GX09-1
	↓	↓			L
	.067	.072			



<b>GX09-1S...R/L</b>  details: page C16	<b>GX09-1R...R/L</b>  details: page C20
--	--

[inch]					type, ordering description
D <sub>min</sub>	s	T <sub>max</sub>	r	T <sub>max</sub>	
.79	.077	.039	.047	.157	MSS-I16R04-GX09-1
	.088	.157			R
	.108				
	.128				
.79	.108	.157			MSS-I16R04-GX09-2
	.108				L
	.128				
	.128				
.128					
.79	.077	.039	.047	.157	MSS-I16L04-GX09-1
	.088	.157			L
	.108				
	.128				
.79	.108	.157			MSS-I16L04-GX09-2
	.108				R
	.128				
	.128				
.98	.077	.039	.047	.197	
	.088	.197			R
	.108				
	.128				
.98	.108	.197			MSS-I20R05-GX09-2
	.077	.039	.047	.197	MSS-I20L05-GX09-1
	.088	.197			L
	.108				
.98	.128	.197			MSS-I20L05-GX09-2
	.108				R
	.128				
	.128				



<b>GX09-.S...N</b>  details: page C17	<b>GX09-.R...N</b>  details: page C20
---	--

## Application

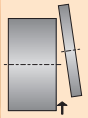

page B2-B15

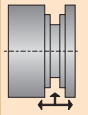

page B16-B23

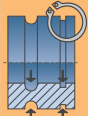

page B24-B49

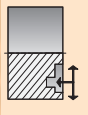

page B50-B59

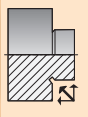

page B60-B65

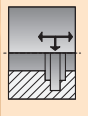

page B66-B77

### Turning

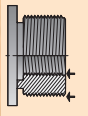

page B78-B93

### Milling

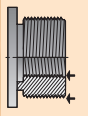

page B78-B93

# Circlip and O-ring grooves (internal) UTS (MSS)

System

GX09...



page B27

GX...



page B28-B33

GX...



page B34-B35

GX09



page B37

GX..



page B38-B43

GX...







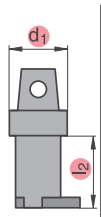



page B44-B49

## UTS boring bar



drawing illustrates right hand execution

details: page D39

Bgr.	[inch]		[mm]		type, ordering description
	l <sub>2</sub>	d <sub>1</sub>	l <sub>2</sub>	d <sub>1</sub>	
I25	1.97	40	50	 UT40-MSS-I25R-2D  UT50-MSS-I25R-2D <b>R</b>	
		50			 UT40-MSS-I25L-2D  UT50-MSS-I25L-2D <b>L</b>
	1.97	40	50	 UT40-MSS-I25L-2D  UT50-MSS-I25L-2D <b>L</b>	
		50			 UT40-MSS-I25R-2D  UT50-MSS-I25R-2D <b>R</b>

Bgr. = assembly size

**ordering example:** 1 piece UT50-MSS-I25R-2D  
2 pieces MSS-I25R02-GX09-1

# GX09 system

## module GX09

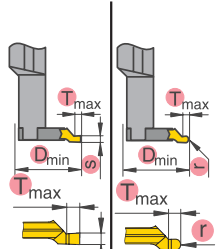

drawing illustrates right hand execution

details: page D26

## module GX09

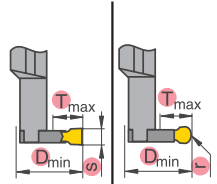

drawing illustrates right hand execution

details: page D28

[inch]					type, ordering description
D <sub>min</sub>	s	T <sub>max</sub>	r	T <sub>max</sub>	
1.26	.024	.029	.031	.070	MSS-I25R02-GX09-1 R
	.031	.037			
	.035	.041			
	.039	.045			
	.047	.053			
	.055	.060			
	.067	.072			
1.26	.024	.029	.031	.070	MSS-I25L02-GX09-1 L
	↓	↓			
	.067	.072			



[inch]					type, ordering description
D <sub>min</sub>	s	T <sub>max</sub>	r	T <sub>max</sub>	
32	.077	.039	.047	.236	MSS-I25R06-GX09-1 R
	.088	.236			
	.108				MSS-I25R06-GX09-2
	.108	.236			
	.128				
32	.077	.039	.047	.236	MSS-I25L06-GX09-1 L
	.088	.236			
	.108				MSS-I25L06-GX09-2
	.108	.236			
	.128				



**GX09-1S...R/L**



details: page C16

**GX09-1R...R/L**



details: page C20

**GX09-.S...N**

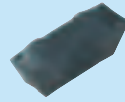

details: page C17

**GX09-.R...N**



details: page C20

Application

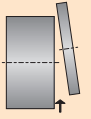

page B2-B15

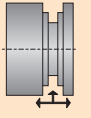

page B16-B23

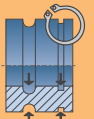

page B24-B49

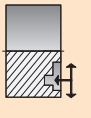

page B50-B59

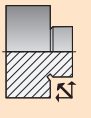

page B60-B65

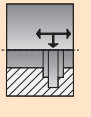

page B66-B77

### Turning

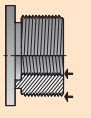

page B78-B93

### Milling

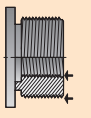

pagp B78-B93

# Circlip and O-ring grooves (internal)

## UTS (MSS)

GX09...



page B27

GX...



page B28-B33

GX...



page B34-B35

GX09



page B37

GX..



page B38-B43

GX...







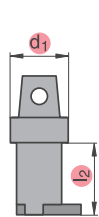



page B44-B49

### UTS boring bar



drawing illustrates right hand execution

details: page D39

Bgr.	[inch]	[mm]	type, ordering description
	l <sub>2</sub>	d <sub>1</sub>	
I32	2.52	40	 UT40-MSS-I32R90-2D
		50	 UT50-MSS-I32R90-2D
		63	<b>R</b> UT63-MSS-I32R90-2D
	2.52	40	 UT40-MSS-I32L90-2D
		50	 UT50-MSS-I32L90-2D
		63	<b>L</b> UT63-MSS-I32L90-2D
I40	3.15	40	 UT40-MSS-I40R90-2D
		50	 UT50-MSS-I40R90-2D
		63	<b>R</b> UT63-MSS-I40R90-2D
	3.15	40	 UT40-MSS-I40L90-2D
		50	 UT50-MSS-I40L90-2D
		63	<b>L</b> UT63-MSS-I40L90-2D

Bgr. = assembly size

**ordering example:** 1 piece UT40-MSS-I40R90-2D  
2 pieces MSS-I40R03-GX16-2

# GX16 system

## module GX16

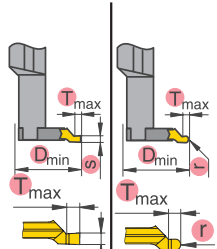

drawing illustrates right hand execution

details: page D27

## module GX16

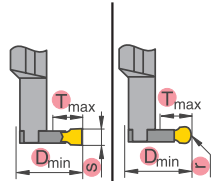

drawing illustrates right hand execution

details: page D29

[inch]					type, ordering description
D <sub>min</sub>	s	T <sub>max</sub>	r	T <sub>max</sub>	
1.57	.024	.029	.031	.070	MSS-I32R03-GX16-2
	.031	.037	.039	.086	R
	.035	.041	.047	.101	
	.039	.045			
	.047	.053			
	.055	.060			
	.067	.072			
	.077	.081			
1.57	.024	.029	.031	.070	MSS-I32L03-GX16-2
	↓	↓	.039	.086	L
	.088	.093	.047	.101	

1.97	.024	.029	.031	.070	MSS-I40R03-GX16-2
	↓	↓	.039	.086	R
	.088	.093	.047	.101	

1.97	.024	.029	.031	.070	MSS-I40L03-GX16-2
	↓	↓	.039	.086	L
	.088	.093	.047	.101	

**GX16-2S...R/L**



details: page C18

**GX16-2R...R/L**



details: page C21

[inch]					type, ordering description	
D <sub>min</sub>	s	T <sub>max</sub>	r	T <sub>max</sub>		
1.57	.108		.059	.354	MSS-I32R09-GX16-2	
	.128				R	
	.167	.354				
	.207					
	1.57	.167	.354	.079	.354	MSS-I32R09-GX16-3
		.207		.098		L
.207		.354	.118	.354		

1.97	.108		.059	.394	MSS-I40R10-GX16-2
	.128				R
	.167	.394			
	.207				
1.97	.167	.394	.079	.394	MSS-I40R10-GX16-3
	.207	.394	.098		L
	.207	.394	.118	.394	
	.207	.394	.118	.394	

1.97	.108		.059	.394	MSS-I40L10-GX16-2	
	.128				L	
	.167	.394				
	.207					
	1.97	.167	.394	.079	.394	MSS-I40L10-GX16-3
		.207	.394	.098		L
.207		.394	.118	.394		

**GX16-S...N**



details: page C19

**GX16-R...N**



details: page C21

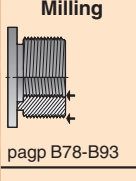
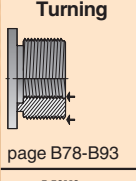
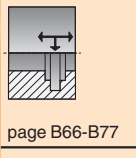
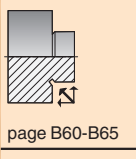
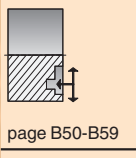
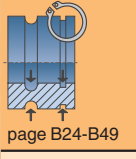
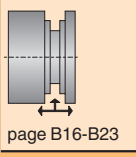
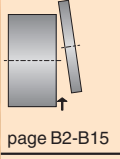



# Axial grooving Overview

GX24



page B52-B55

GX24



page B56-B59

**shank 0°**

**h / b**  
.625/.787 - 1.250/1.250

**shank 90°**





**h / b**  
.750/.750 - 1.250/1.250



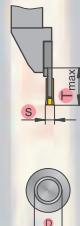

**UTS 0°**

**d1**  
40 - 63 mm

**UTS 90°**

**d1**  
40 - 63 mm

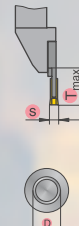
	<p><b>short axial GX module</b></p> <p><math>s = .118 - .236</math>  <math>T_{max} = .59</math>  <math>D = 1.97 - 35.43</math></p> 
	<p><b>short axial GX module</b></p> <p><math>s = .118 - .236</math>  <math>T_{max} = .59</math>  <math>D = 1.97 - 35.43</math></p> 

	<p><b>long axial GX module</b></p> <p><math>s = .157 - .236</math>  <math>T_{max} = .98</math>  <math>D = 2.75 - 11.81</math></p> 
	<p><b>long axial GX module</b></p> <p><math>s = .157 - .236</math>  <math>T_{max} = .98</math>  <math>D = 2.75 - 11.81</math></p> 

D > 19.68 inch see pages D21 and E25!

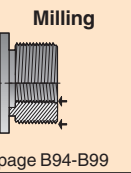
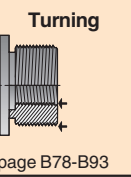
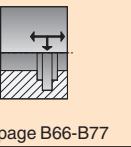
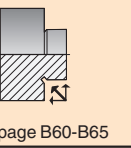
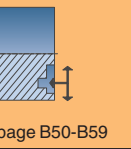
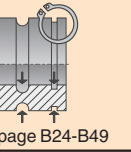
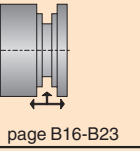
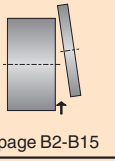

GX24



page B52-55

GX24



page B56-B59

# Axial grooving Modular system (MSS)

## shank 0°

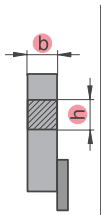

drawing illustrates right hand execution



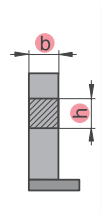



## shank 90°







drawing illustrates right hand execution

details: page D2

details: page D3

Bgr.	[inch]		type, ordering description
	h	b	
E20	.625	.787	 MSS-E20R00-10-E  MSS-E20R00-12-E R
	.750	.750	
	.625	.787	 MSS-E20L00-10-E  MSS-E20L00-12-E L
	.750	.750	
E25	1.000	1.000	 MSS-E25R00-16-E R
	1.000	1.000	 MSS-E25L00-16-E L

Bgr.	[inch]		type, ordering description
	h	b	
E20	.750	.750	 MSS-E20L90-12-E L
	.750	.750	 MSS-E20R90-12-E R
E25	1.000	1.000	 MSS-E25L90-16-E L
	1.000	1.000	 MSS-E25R90-16-E R

Bgr. = assembly size

**ordering example:** 1 piece MSS-E20L00-12-E  
2 pieces MSS-E20R14-GX24-2 A70-100



attention in case of 90°:

right hand shank – left module  
left hand shank – right module

# GX24 system

Application

## short axial GX module

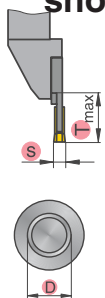

drawing illustrates right hand execution

details: page D17 - D18

[inch]			type, ordering description
s	T <sub>max</sub>	D	
.109 - .148	.55	1.97 - 2.76	MSS-E20R14-GX24-2 A50-70
		2.76 - 3.94	MSS-E20R14-GX24-2 A70-100
		3.94 - 5.91	<b>R</b> MSS-E20R14-GX24-2A100-150
.109 - .148	.55	1.97 - 2.76	MSS-E20L14-GX24-2 A50-70
		2.76 - 3.94	MSS-E20L14-GX24-2 A70-100
		3.94 - 5.91	<b>L</b> MSS-E20L14-GX24-2A100-150
.109 - .148	.59	1.97 - 2.76	MSS-E25R15-GX24-2 A50-70
		2.76 - 3.94	MSS-E25R15-GX24-2 A70-100
		3.94 - 5.91	<b>R</b> MSS-E25R15-GX24-2 A100-150
.148 - .197	.59	1.97 - 2.76	MSS-E25R15-GX24-3 A50-70
		2.76 - 3.94	MSS-E25R15-GX24-3 A70-100
		3.94 - 5.91	MSS-E25R15-GX24-3 A100-150
		5.91-11.81	<b>R</b> MSS-E25R15-GX24-3 A150-300
.197 - .256	.59	1.97 - 2.76	MSS-E25R15-GX24-4 A50-70
		2.76 - 3.94	MSS-E25R15-GX24-4 A70-100
		3.94 - 5.91	MSS-E25R15-GX24-4 A100-150
		5.91-11.81	<b>R</b> MSS-E25R15-GX24-4 A150-300
.109 - .148	.59	1.97 - 2.76	MSS-E25L15-GX24-2 A50-70
		2.76 - 3.94	MSS-E25L15-GX24-2 A70-100
		3.94 - 5.91	<b>L</b> MSS-E25L15-GX24-2 A100-150
.148 - .197	.59	1.97 - 2.76	MSS-E25L15-GX24-3 A50-70
		2.76 - 3.94	MSS-E25L15-GX24-3 A70-100
		3.94 - 5.91	MSS-E25L15-GX24-3 A100-150
		5.91-11.81	<b>L</b> MSS-E25L15-GX24-3 A150-300
.197 - .256	.59	1.97 - 2.76	MSS-E25L15-GX24-4 A50-70
		2.76 - 3.94	MSS-E25L15-GX24-4 A70-100
		3.94 - 5.91	MSS-E25L15-GX24-4 A100-150
		5.91-11.81	<b>L</b> MSS-E25L15-GX24-4 A150-300



**GX24E**

details: page C11

**GX24R**

details: page C14

## long axial GX module

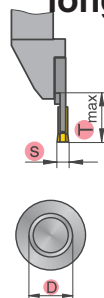

drawing illustrates right hand execution

details: page D19

[inch]			type, ordering description
s	T <sub>max</sub>	D	
.148 - .197	.83	1.97 - 2.76	MSS-E25R21-GX24-3 AS50-70
		2.76 - 3.94	MSS-E25R21-GX24-3 AS70-100
		3.94 - 5.91	MSS-E25R21-GX24-3 AS100-150
.197 - .256	.98	5.91-11.81	<b>R</b> MSS-E25R21-GX24-3 AS150-300
		1.97 - 2.76	MSS-E25R25-GX24-4 AS50-70
		2.76 - 3.94	MSS-E25R25-GX24-4 AS70-100
		3.94 - 5.91	MSS-E25R25-GX24-4 AS100-150
.197 - .256	.98	5.91-11.81	<b>R</b> MSS-E25R25-GX24-4 AS150-300
		1.97 - 2.76	MSS-E25L21-GX24-3 AS50-70
		2.76 - 3.94	MSS-E25L21-GX24-3 AS70-100
		3.94 - 5.91	MSS-E25L21-GX24-3 AS100-150
.197 - .256	.98	5.91-11.81	<b>L</b> MSS-E25L21-GX24-3 AS150-300
		1.97 - 2.76	MSS-E25L25-GX24-4 AS50-70
		2.76 - 3.94	MSS-E25L25-GX24-4 AS70-100
		3.94 - 5.91	MSS-E25L25-GX24-4 AS100-150
.197 - .256	.98	5.91-11.81	<b>L</b> MSS-E25L25-GX24-4 AS150-300



**GX24E**

details: page C11

**GX24R**

details: page C14

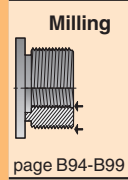
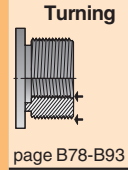
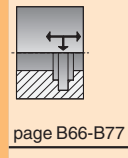
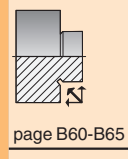
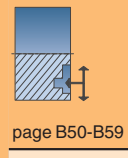
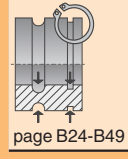
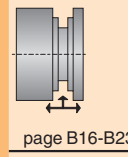
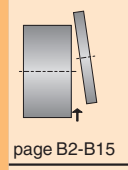

# Axial grooving Modular system (MSS)

GX



page B52-55

GX24



page B56-B59

## shank 0°

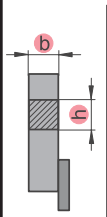

drawing illustrates right hand execution



details: page D2

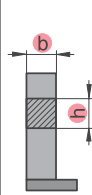

## shank 90°



drawing illustrates right hand execution

details: page D3

Bgr.	[inch]		type, ordering description
	h	b	
E32	1.250	1.000	 MSS-E32R00-85-E MSS-E32R00-20-E
	1.250	1.250	
	1.250	1.000	 MSS-E32L00-85-E MSS-E32L00-20-E
	1.250	1.250	

Bgr.	[inch]		type, ordering description
	h	b	
E32	1.250	1.000	 MSS-E32R90-85-E MSS-E32R90-20-E
	1.250	1.250	
	1.250	1.000	 MSS-E32L90-85-E MSS-E32L90-20-E
	1.250	1.250	

Bgr. = assembly size

**ordering example:** 1 piece MSS-E32L00-85-E  
2 pieces MSS-E32L15-GX24-4 A100-150



**attention in case of 90°:**

right hand shank – left module  
left hand shank – right module



# GX24 system

## short axial GX module

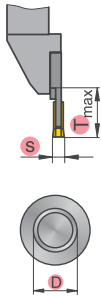

drawing illustrates right hand execution

details: page D20

[inch]			type, ordering description
s	T <sub>max</sub>	D	
.148 .197	.59	2.76 - 3.94	MSS-E32R15-GX24-3 A70-100
		3.94 - 5.91	MSS-E32R15-GX24-3 A100-150
		5.91-11.81	<b>R</b> MSS-E32R15-GX24-3 A150-300
.197 - .256		2.76 - 3.94	MSS-E32R15-GX24-4 A70-100
		3.94 - 5.91	MSS-E32R15-GX24-4 A100-150
		5.91-11.81	MSS-E32R15-GX24-4 A150-300
		11.81-35.43	MSS-E32R15-GX24-4 A300-900
.148 .197	.59	2.76 - 3.94	MSS-E32L15-GX24-3 A70-100
		3.94 - 5.91	MSS-E32L15-GX24-3 A100-150
		5.91-11.81	<b>L</b> MSS-E32L15-GX24-3 A150-300
.197 - .256	.59	2.76 - 3.94	MSS-E32L15-GX24-4 A70-100
		3.94 - 5.91	MSS-E32L15-GX24-4 A100-150
		5.91-11.81	MSS-E32L15-GX24-4 A150-300
		11.81-35.43	MSS-E32L15-GX24-4 A300-900



### GX24E



details: page C11

### GX24R



details: page C14

## Application

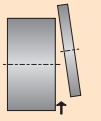

page B2-B15

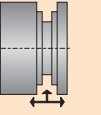

page B16-B23

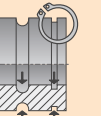

page B24-B49

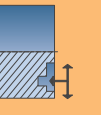

page B50-B59

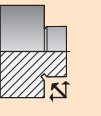

page B60-B65

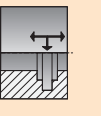

page B66-B77

### Turning

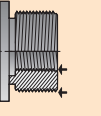

page B78-B93

### Milling

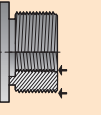

page B94-B99

GX24



page B52-B55

GX



page B56-59

# Axial grooving UTS (MSS)

## UTS 0°

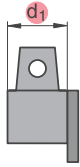

drawing illustrates right hand execution

details: page D10

## UTS 90°

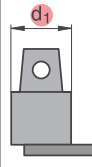

drawing illustrates right hand execution

details: page D11

Bgr.	[mm]	type, ordering description
	d <sub>1</sub>	
E25	40	UT40-MSS-E25R00
	50	UT50-MSS-E25R00
	63	<b>R</b> UT63-MSS-E25R00
	40	UT40-MSS-E25L00
	50	UT50-MSS-E25L00
	63	<b>L</b> UT63-MSS-E25L00

Bgr.	[mm]	type, ordering description
	d <sub>1</sub>	
E25	40	UT40-MSS-E25L90
	50	UT50-MSS-E25L90
	63	<b>L</b> UT63-MSS-E25L90
	40	UT40-MSS-E25R90
	50	UT50-MSS-E25R90
	63	<b>R</b> UT63-MSS-E25R90

Bgr. = assembly size

**ordering example:** 1 piece UT40-MSS-E25L00  
2 pieces MSS-E25L15-GX24-2 A50-70



**attention in case of 90°:**

right hand UTS holder – left module  
left hand UTS holder – right module

# GX24 system

## short axial GX module

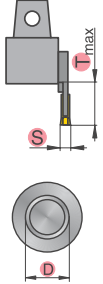

drawing illustrates right hand execution

details: page D18

## long axial GX module

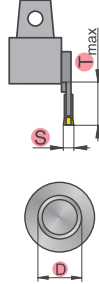

drawing illustrates right hand execution

details: page D19

[inch]			type, ordering description
s	T <sub>max</sub>	D	
.109 - .148	.59	1.97 - 2.76	MSS-E25R15-GX24-2 A50-70
		2.76 - 3.94	MSS-E25R15-GX24-2 A70-100
		3.94 - 5.91	<b>R</b> MSS-E25R15-GX24-2 A100-150
.148/ .197	.59	1.97 - 2.76	MSS-E25R15-GX24-3 A50-70
		2.76 - 3.94	MSS-E25R15-GX24-3 A70-100
		3.94 - 5.91	MSS-E25R15-GX24-3 A100-150
		5.91-11.81	MSS-E25R15-GX24-3 A150-300
.197 - .256	.59	1.97 - 2.76	MSS-E25R15-GX24-4 A50-70
		2.76 - 3.94	MSS-E25R15-GX24-4 A70-100
		3.94 - 5.91	MSS-E25R15-GX24-4 A100-150
		5.91-11.81	MSS-E25R15-GX24-4 A150-300
.109 - .148	.59	1.97 - 2.76	MSS-E25L15-GX24-2 A50-70
		2.76 - 3.94	MSS-E25L15-GX24-2 A70-100
		3.94 - 5.91	<b>L</b> MSS-E25L15-GX24-2 A100-150
.148/ .197	.59	1.97 - 2.76	MSS-E25L15-GX24-3 A50-70
		2.76 - 3.94	MSS-E25L15-GX24-3 A70-100
		3.94 - 5.91	MSS-E25L15-GX24-3 A100-150
		5.91-11.81	MSS-E25L15-GX24-3 A150-300
.197 - .256	.59	1.97 - 2.76	MSS-E25L15-GX24-4 A50-70
		2.76 - 3.94	MSS-E25L15-GX24-4 A70-100
		3.94 - 5.91	MSS-E25L15-GX24-4 A100-150
		5.91-11.81	MSS-E25L15-GX24-4 A150-300



**GX24E**

details: page C11

**GX24R**

details: page C14

[inch]			type, ordering description
s	T <sub>max</sub>	D	
.148/ .197	.83	1.97 - 2.76	MSS-E25R21-GX24-3 AS50-70
		2.76 - 3.94	MSS-E25R21-GX24-3 AS70-100
		3.94 - 5.91	MSS-E25R21-GX24-3 AS100-150
.197 - .256	.98	5.91-11.81	<b>R</b> MSS-E25R21-GX24-3 AS150-300
		1.97 - 2.76	MSS-E25R25-GX24-4 AS50-70
		2.76 - 3.94	MSS-E25R25-GX24-4 AS70-100
		3.94 - 5.91	MSS-E25R25-GX24-4 AS100-150
.148/ .197	.83	5.91-11.81	<b>R</b> MSS-E25R25-GX24-4 AS150-300
		1.97 - 2.76	MSS-E25L21-GX24-3 AS50-70
		2.76 - 3.94	MSS-E25L21-GX24-3 AS70-100
		3.94 - 5.91	MSS-E25L21-GX24-3 AS100-150
.197 - .256	.98	5.91-11.81	<b>L</b> MSS-E25L21-GX24-3 AS150-300
		1.97 - 2.76	MSS-E25L25-GX24-4 AS50-70
		2.76 - 3.94	MSS-E25L25-GX24-4 AS70-100
		3.94 - 5.91	MSS-E25L25-GX24-4 AS100-150
.197 - .256	.98	5.91-11.81	MSS-E25L25-GX24-4 AS150-300



**GX24E**

details: page C11

**GX24R**

details: page C14

## Application

page B2-B15

page B16-B23

page B24-B49

page B50-B59

page B60-B65

page B66-B77

**Turning**

page B78-B93

**Milling**

page B94-B99

GX24



page B52-B55

GX



page B56-59

# Axial grooving UTS (MSS)

## UTS 0°

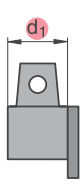

drawing illustrates right hand execution



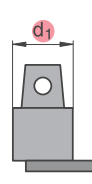

details: page D10



## UTS 90°



drawing illustrates right hand execution

details: page D11

Bgr.	[mm]	type, ordering description
	d <sub>1</sub>	
E32	50	 UT50-MSS-E32R00
	63	 UT63-MSS-E32R00
	50	 UT50-MSS-E32L00
	63	 UT63-MSS-E32L00

Bgr.	[mm]	type, ordering description
	d <sub>1</sub>	
E32	63	 UT63-MSS-E32L90
	63	 UT63-MSS-E32R90

Bgr. = assembly size

**ordering example:** 1 piece UT63-MSS-E32L90  
2 pieces MSS-E32R15-GX24-4 A100-150



**attention in case of 90°:**

right hand UTS holder – left module  
left hand UTS holder – right module

# GX24 system

## short axial GX module

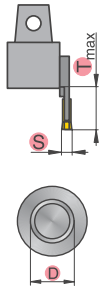

drawing illustrates right hand execution

details: page D20

[inch]			type, ordering description
s	T <sub>max</sub>	D	
.148/ .197	.59	2.76 - 3.94	MSS-E32R15-GX24-3 A70-100
		3.94 - 5.91	MSS-E32R15-GX24-3 A100-150
		5.91-11.81	<b>R</b> MSS-E32R15-GX24-3 A150-300
.197 - .256	.59	2.76 - 3.94	MSS-E32R15-GX24-4 A70-100
		3.94 - 5.91	MSS-E32R15-GX24-4 A100-150
		5.91-11.81	MSS-E32R15-GX24-4 A150-300
		11.81-35.43	MSS-E32R15-GX24-4 A300-900
.148/ .197	.59	2.76 - 3.94	MSS-E32L15-GX24-3 A70-100
		3.94 - 5.91	MSS-E32L15-GX24-3 A100-150
		5.91-11.81	<b>L</b> MSS-E32L15-GX24-3 A150-300
.197 - .256	.59	2.76 - 3.94	MSS-E32L15-GX24-4 A70-100
		3.94 - 5.91	MSS-E32L15-GX24-4 A100-150
		5.91-11.81	MSS-E32L15-GX24-4 A150-300
		11.81-35.43	MSS-E32L15-GX24-4 A300-900



### GX24E



details: page C11

### GX24R



details: page C14

## Application

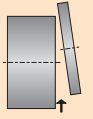

page B2-B15

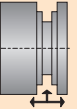

page B16-B23

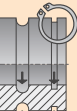

page B24-B49

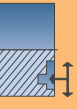

page B50-B59

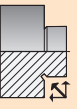

page B60-B65

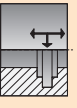

page B66-B77

### Turning

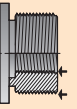

page B78-B93

### Milling

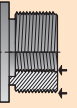

page B94-B99



# External recessing Overview

GX16



page B62-B63

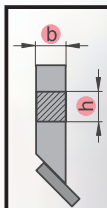

shank 45°

**h / b**  
.750/.750 - 1.000/1.000



GX16



page B64-B65

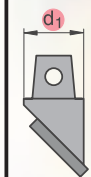

UTS 45°

**d1**  
40 mm



	<p><b>module GX16</b></p> <p><math>s = .039 - .236</math>  <math>T_{max} = .045 - .079</math>  <math>r = .031 - .118</math></p>
	<p><b>module GX16</b></p> <p><math>s = .039 - .236</math>  <math>T_{max} = .045 - .079</math>  <math>r = .031 - .118</math></p>

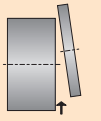

page B2-B15

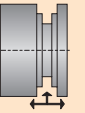

page B16-B23

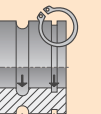

page B24-B49

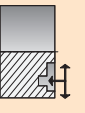

page B50-B59



page B60-B65

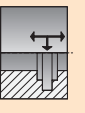

page B66-B77

**Turning**

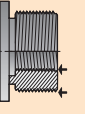

page B78-B93

**Milling**

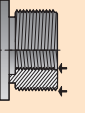

page B94-B99

GX16



page B62-B63

GX16



page B64-B65

# External recessing



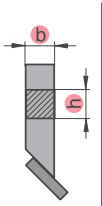

## Modular system (MSS)

shank 45°



drawing illustrates right hand execution

details: page D4

Bgr.	[inch]		type, ordering description
	h	b	
E20	.750	.750	 MSS-E20R45-12-E
	.750	.750	 MSS-E20L45-12-E
E25	1.000	1.000	 MSS-E25R45-16-E
	1.000	1.000	 MSS-E25L45-16-E

Bgr. = assembly size

**ordering example:** 1 piece MSS-E25L45-16-E  
2 pieces MSS-E25R03-GX16-2



attention in case of 45°:

right hand shank – left module  
left hand shank – right module

# GX16 system

## module GX16

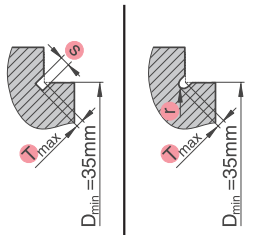

drawing illustrates right hand execution

details: page D13

## module GX16

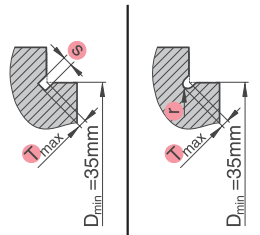

drawing illustrates right hand execution

details: page D13

[inch]				type, ordering description
s	T <sub>max</sub>	r	T <sub>max</sub>	
.039	.045	.031	.070	L MSS-E20L03-GX16-2
.047	.053	.039	.079	
.055	.060	.047	.079	
.067	.072			
.077	.079			
.088	.079			
.039	.045	.031	.070	R MSS-E20R03-GX16-2
↓	↓	.039	.079	
.088	.079	.047	.079	
.039	.045	.031	.070	L MSS-E25L03-GX16-2
↓	↓	.039	.086	
.088	.079	.047	.101	
.039	.045	.031	.070	R MSS-E25R03-GX16-2
↓	↓	.039	.086	
.088	.079	.047	.101	



[inch]				type, ordering description	
s	T <sub>max</sub>	r	T <sub>max</sub>		
.118	.079	.059	.079	L MSS-E20L03-GX16-2	
.128		.079			
.138		.098			
.157					
.167					
.177					
.197			R MSS-E20R03-GX16-2		
↓	.079	.079		.079	
.197		.098			
.118	.079	.059	.079	L MSS-E25L03-GX16-2	
↓		.079			.079
.197		.098			
.207	.079	.118	.079	R MSS-E25R03-GX16-2	
.236		.118			
.118	.079	.059	.079	R MSS-E25R03-GX16-2	
↓		.079			.079
.197		.098			
.207		.118			
.236					



**GX16-2S...R/L**



details: page C18

**GX16-2R...R/L**



details: page C21

**GX16...N**



details: page C19

**GX16-.R...N**



details: page C21

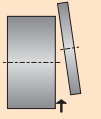

page B2-B15

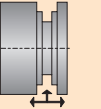

page B16-B23

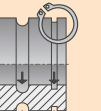

page B24-B49

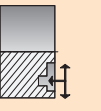

page B50-B59

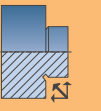

page B60-B65

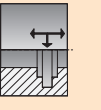

page B66-B77

### Turning

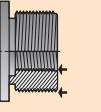

page B78-B93

### Milling

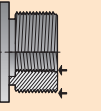

page B94-B99

GX16



page B62-B63

GX16



page B64-B65

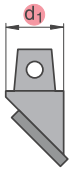

# External recessing UTS (MSS)

UTS 45°



drawing illustrates right hand execution

details: page D38

	[mm]	
Bgr.	d <sub>1</sub>	type, ordering description
E25	40	 UT40-MSS-E25R45 R
	40	 UT40-MSS-E25L45 L

Bgr. = assembly size

**ordering example:** 1 piece UT50-MSS-E25L45  
2 pieces MSS-E25R03-GX16-2



**attention in case of 45°:**

right hand UTS holder – left module  
left hand UTS holder – right module



# GX16 system

## module GX16

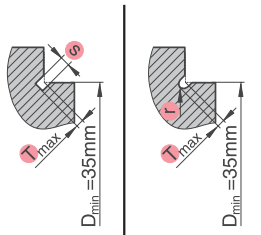

drawing illustrates right hand execution

details: page D13

## module GX16

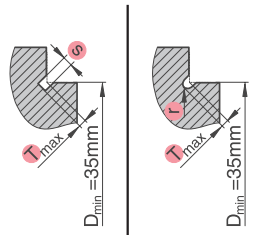

drawing illustrates right hand execution

details: page D13

[inch]				type, ordering description
s	T <sub>max</sub>	r	T <sub>max</sub>	
.039	.045	.031	.070	MSS-E25L03-GX16-2 L
.047	.053	.039	.079	
.055	.060	.047	.079	
.067	.072			
.077	.079			
.088	.079			
.039	.045	.031	.070	
.047	.053	.039	.079	
.055	.060	.047	.079	
.067	.072			
.077	.079			
.088	.079			



[inch]				type, ordering description	
s	T <sub>max</sub>	r	T <sub>max</sub>		
.118	.079	.059	.079	MSS-E25L03-GX16-2 L	
.128		.079	.079		
.138		.098	.079		
.157		.118	.079		
.167					
.177					
.197					
.207	.079			MSS-E25R03-GX16-2 R	
.236					
.118	.079	.059	.079		MSS-E25L03-GX16-2 L
.128		.079	.079		
.138		.098	.079		
.157		.118	.079		
.167					
.177					
.197					
.207	.079			MSS-E25R03-GX16-2 R	
.236					



**GX16-2S...R/L**



details: page C18

**GX16-2R...R/L**



details: page C21

**GX16...N**

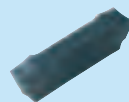

details: page C19

**GX16-.R...N**



details: page C21

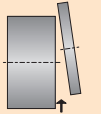

page B2-B15

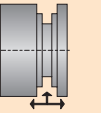

page B16-B23

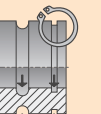

page B24-B49

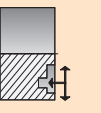

page B50-B59



page B60-B65

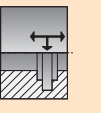

page B66-B77

### Turning

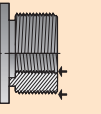

page B78-B93

### Milling

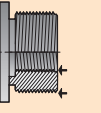

page B94-B99

# Grooving and turning (internal) Overview

System

GX09...



page B69

GX...



page B70-B73

GX...



page B74-B77

	<p><b>monobloc boring bar</b></p> <p><math>D_{min} = .63</math>      <math>s = .079 - .148</math>  <math>l_2 = 1.18</math>      <math>d_1 = .625</math>      <math>T_{max} = .118</math></p>	
	<p><b>boring bar 1.5D</b></p> <p><math>d_1 = .750 - 1.500</math>  <math>l_2 = .94 - 2.36</math></p>	<p><b>boring bar 2.5D</b></p> <p><math>d_1 = .750 - 2.000</math>  <math>l_2 = 1.57 - 3.94</math></p>
	<p><b>UTS boring bar</b></p> <p><math>d_1 = 40 - 63 \text{ mm}</math>  <math>l_2 = 1.26 - 3.15 \text{ inch}</math></p>	

	<p><b>module GX09</b></p>  <p><math>D_{min} = .79 - 1.26</math>  <math>s = .079 - .148</math>  <math>T_{max} = .157 - .236</math></p>		<p><b>module GX16</b></p>  <p><math>D_{min} = 1.57 - 1.97</math>  <math>s = .079 - .256</math>  <math>T_{max} = .354 - .394</math></p>		<p><b>module GX24</b></p>  <p><math>D_{min} = 2.36</math>  <math>s = .118 - .236</math>  <math>T_{max} = .748</math></p>
	<p><b>module GX09</b></p>  <p><math>D_{min} = .79 - 1.26</math>  <math>s = .079 - .148</math>  <math>T_{max} = .157 - .236</math></p>		<p><b>module GX16</b></p>  <p><math>D_{min} = 1.57 - 1.97</math>  <math>s = .079 - .256</math>  <math>T_{max} = .354 - .394</math></p>		<p><b>module GX24</b></p>  <p><math>D_{min} = 2.36</math>  <math>s = .118 - .236</math>  <math>T_{max} = .748</math></p>

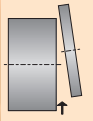

page B2-B15

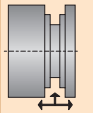

page B16-B23

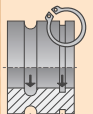

page B24-B49

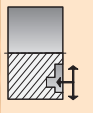

page B50-B59

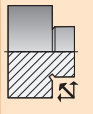

page B60-B65

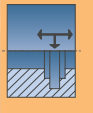

page B66-B77

**Turning**

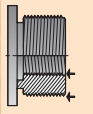

page B78-B93

**Milling**

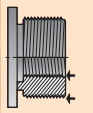

pagp B78-B93

GX09...



page B69

GX...



page B70-B73

GX...



page B74-B77

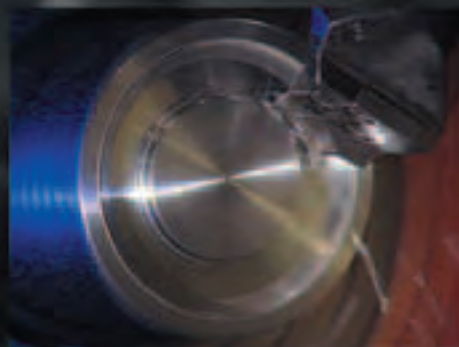

# Grooving and turning (internal)

## Modular system (MSS)

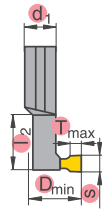

Application

### monobloc boring bar



drawing illustrates right hand execution

details: page D23

Bgr.	[inch]					type, ordering description
	D <sub>min</sub>	l <sub>2</sub>	d <sub>1</sub>	s	T <sub>max</sub>	
I12	.63	1.18	.625	.079 - .148	.118	 I12R90-2.5D-GX09-E R
	.63	1.18	.625	.079 - .148	.118	 I12L90-2.5D-GX09-E L

Bgr. = assembly size



ordering example: 1 piece I12R90-2.5D-GX09-E

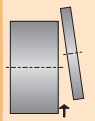

page B2-B15

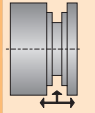

page B16-B23

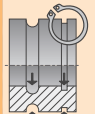

page B24-B49

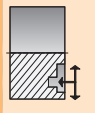

page B50-B59

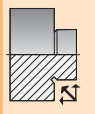

page B60-B65

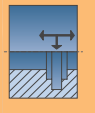

page B66-B77

#### Turning

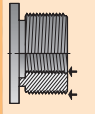

page B78-B93

#### Milling

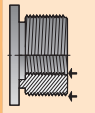

page B78-B93

**GX09E**



details: page C8

**GX09R**



details: page C12

B69



# Grooving and turning (internal)

## Modular system (MSS)

System

GX09...

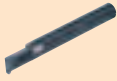

page B69

GX...



page B70-B73

GX...



page B74-B77

### boring bar 1.5D

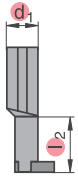

drawing illustrates right hand execution





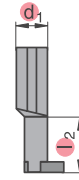

details: page D24







### boring bar 2.5D



drawing illustrates right hand execution

details: page D25

Bgr.	[inch]		type, ordering description
	l <sub>2</sub>	d <sub>1</sub>	
I16	.94	.750	 MSS-I16R90-1.5D-E
	.94	.750	 MSS-I16L90-1.5D-E
I20	1.18	.750	 MSS-I20R90-1.5D-E
	1.18	.750	 MSS-I20L90-1.5D-E
I25	1.50	1.000	 MSS-I25R90-1.5D-E
	1.50	1.000	 MSS-I25L90-1.5D-E

Bgr.	[inch]		type, ordering description
	l <sub>2</sub>	d <sub>1</sub>	
I16	1.57	.750	 MSS-I16R90-2.5D-E
	1.57	.750	 MSS-I16L90-2.5D-E
I20	1.97	1.000	 MSS-I20R90-2.5D-E
	1.97	1.000	 MSS-I20L90-2.5D-E
I25	2.48	1.250	 MSS-I25R90-2.5D-E
	2.48	1.250	 MSS-I25L90-2.5D-E

Bgr. = assembly size

**ordering example:** 1 piece MSS-I25R90-1.5D-E  
2 pieces MSS-I25R06-GX09-2





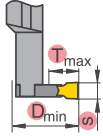

# GX09 system

## module GX09



drawing illustrates right hand execution

details: page D28

[inch]			type, ordering description
D <sub>min</sub>	s	T <sub>max</sub>	
.79	.079 - .108	.157	MSS-I16R04-GX09-1
	.109 - .148		 MSS-I16R04-GX09-2 <b>R</b>
.79	.079 - .108	.157	MSS-I16L04-GX09-1
	.109 - .148		 MSS-I16L04-GX09-2 <b>L</b>
.98	.079 - .108	.197	MSS-I20R05-GX09-1
	.109 - .148		 MSS-I20R05-GX09-2 <b>R</b>
.98	.079 - .108	.197	MSS-I20L05-GX09-1
	.109 - .148		 MSS-I20L05-GX09-2 <b>L</b>
1.26	.079 - .108	.236	MSS-I25R06-GX09-1
	.109 - .148		 MSS-I25R06-GX09-2 <b>R</b>
1.26	.079 - .108	.236	MSS-I25L06-GX09-1
	.109 - .148		 MSS-I25L06-GX09-2 <b>L</b>



**GX09**

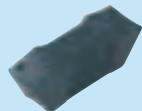

details: page C8

**GX09R**



details: page C12

Application

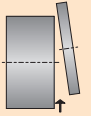

page B2-B15

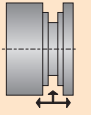

page B16-B23

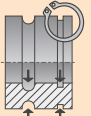

page B24-B49

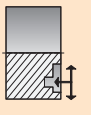

page B50-B59

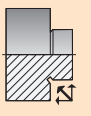

page B60-B65

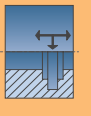

page B66-B77

**Turning**

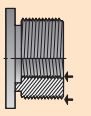

page B78-B93

**Milling**

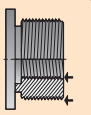

pagp B78-B93

# Grooving and turning (internal)

## Modular system (MSS)

System

GX09...



page B69

GX...



page B70-B73

GX...



page B74-B77

### boring bar 1.5D

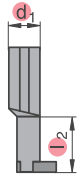

drawing illustrates right hand execution



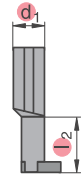

details: page D24





### boring bar 2.5D



drawing illustrates right hand execution

details: page D25

Bgr.	l <sub>2</sub>	d <sub>1</sub>	type, ordering description
I32	1.89	1.250	 MSS-I32R90-1.5D-E
	1.89	1.250	 MSS-I32L90-1.5D-E
I40	2.36	1.500	 MSS-I40R90-1.5D-E
	2.36	1.500	 MSS-I40L90-1.5D-E

Bgr.	l <sub>2</sub>	d <sub>1</sub>	type, ordering description
I32	3.15	1.500	 MSS-I32R90-2.5D-E
	3.15	1.500	 MSS-I32L90-2.5D-E
I40	3.94	2.000	 MSS-I40R90-2.5D-E
	3.94	2.000	 MSS-I40L90-2.5D-E

Bgr. = assembly size

**ordering example:** 1 piece MSS-I32L90-1.5D-E  
2 pieces MSS-I32L09-GX16-2

# GX16 / GX24 system

Application

## module GX16

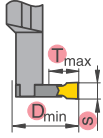

drawing illustrates right hand execution

details: page D29

## module GX24

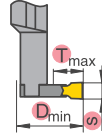

details: page D29

Dmin	s	Tmax	type, ordering description
1.57	.079 - .108	.354	MSS-I32R09-GX16-1
	.109 - .148		MSS-I32R09-GX16-2
	.148 - .197		<b>R</b> MSS-I32R09-GX16-3
	.197 - .256		MSS-I32R09-GX16-4
	.079 - .108	.354	MSS-I32L09-GX16-1
	.109 - .148		MSS-I32L09-GX16-2
	.148 - .197		<b>L</b> MSS-I32L09-GX16-3
	.197 - .256		MSS-I32L09-GX16-4
1.97	.079 - .108	.394	MSS-I40R10-GX16-1
	.109 - .148		MSS-I40R10-GX16-2
	.148 - .197		<b>R</b> MSS-I40R10-GX16-3
	.197 - .256		MSS-I40R10-GX16-4
	.079 - .108	.394	MSS-I40L10-GX16-1
	.109 - .148		MSS-I40L10-GX16-2
	.148 - .197		<b>L</b> MSS-I40L10-GX16-3
	.197 - .256		MSS-I40L10-GX16-4



Dmin	s	Tmax	type, ordering description
2.36	.109 - .148	.748	MSS-I40N19-GX24-2
	.148 - .197		MSS-I40N19-GX24-3
	.197 - .256		<b>N</b> MSS-I40N19-GX24-4
	.109 - .148	.748	MSS-I40N19-GX24-2
	.148 - .197		MSS-I40N19-GX24-3
	.197 - .256		<b>N</b> MSS-I40N19-GX24-4



<b>GX16</b>  details: page C9 - C10	<b>GX16R</b>  details: page C13
---	---------------------------------------

<b>GX24E</b>  details: page C11	<b>GX24R</b>  details: page C14
---------------------------------------	---------------------------------------

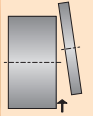

page B2-B15

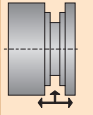

page B16-B23

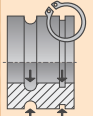

page B24-B49

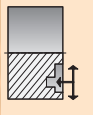

page B50-B59

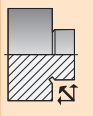

page B60-B65

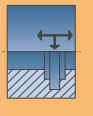

page B66-B77

### Turning

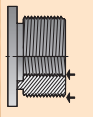

page B78-B93

### Milling

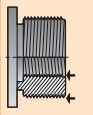

page B78-B93

# Grooving and turning (internal) UTS (MSS)

System

GX09...



page B69

GX...



page B70-B73

GX...







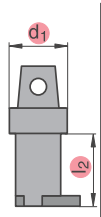



page B74-B77

## UTS boring bar



drawing illustrates right hand execution

details: page D39

Bgr.	[inch]		type, ordering description
	l <sub>2</sub>	d <sub>1</sub>	
I16	1.26	40	 UT40-MSS-I16R90-2D <b>R</b>
	1.26	40	 UT40-MSS-I16L90-2D <b>L</b>
I20	1.57	40	 UT40-MSS-I20R90-2D <b>R</b>
	1.57	40	 UT40-MSS-I20L90-2D <b>L</b>
I25	1.97	40	 UT40-MSS-I25R90-2D <b>R</b>
		50	 UT50-MSS-I25R90-2D <b>R</b>
	1.97	40	 UT40-MSS-I25L90-2D <b>L</b>
		50	 UT50-MSS-I25L90-2D <b>L</b>

Bgr. = assembly size

**ordering example:** 1 piece UT40-MSS-I20R90-2D  
2 pieces MSS-I20R05-GX09-1







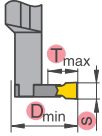

# GX09 system

## module GX09



drawing illustrates right hand execution

details: page D28

[inch]			type, ordering description
D <sub>min</sub>	s	T <sub>max</sub>	
.79	.079 - .108	.157	MSS-I16R04-GX09-1
	.109 - .148		 MSS-I16R04-GX09-2 <b>R</b>
.79	.079 - .108	.157	MSS-I16L04-GX09-1
	.109 - .148		 MSS-I16L04-GX09-2 <b>L</b>
.98	.079 - .108	.197	MSS-I20R05-GX09-1
	.109 - .148		 MSS-I20R05-GX09-2 <b>R</b>
.98	.079 - .108	.197	MSS-I20L05-GX09-1
	.109 - .148		 MSS-I20L05-GX09-2 <b>L</b>
1.26	.079 - .108	.236	MSS-I25R06-GX09-1
	.109 - .148		 MSS-I25R06-GX09-2 <b>R</b>
1.26	.079 - .108	.236	MSS-I25L06-GX09-1
	.109 - .148		 MSS-I25L06-GX09-2 <b>L</b>



**GX09**

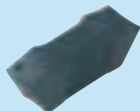

details: page C8

**GX09R**



details: page C12

Application

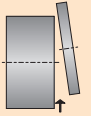

page B2-B15

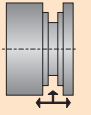

page B16-B23

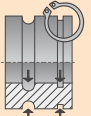

page B24-B49

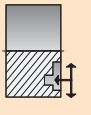

page B50-B59

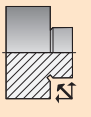

page B60-B65

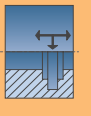

page B66-B77

**Turning**

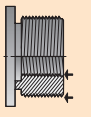

page B78-B93

**Milling**

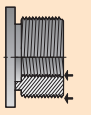

pagp B78-B93

# Grooving and turning (internal) UTS (MSS)

System

GX09...



page B69

GX...



page B70-B73

GX...







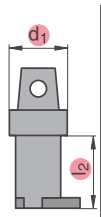



page B74-B77

## UTS boring bar



drawing illustrates right hand execution

details: page D39

Bgr.	[inch]		type, ordering description
	l <sub>2</sub>	d <sub>1</sub>	
I32	2.52	40	 UT40-MSS-I32R90-2D
		50	 UT50-MSS-I32R90-2D
		63	<b>R</b> UT63-MSS-I32R90-2D
	2.52	40	 UT40-MSS-I32L90-2D
		50	 UT50-MSS-I32L90-2D
		63	<b>L</b> UT63-MSS-I32L90-2D
I40	3.15	40	 UT40-MSS-I40R90-2D
		50	 UT50-MSS-I40R90-2D
		63	<b>R</b> UT63-MSS-I40R90-2D
	3.15	40	 UT40-MSS-I40L90-2D
		50	 UT50-MSS-I40L90-2D
		63	<b>L</b> UT63-MSS-I40L90-2D

Bgr. = assembly size

ordering example: 1 piece UT40-MSS-I40R90-2D  
2 pieces MSS-I40N19-GX24-3

# GX16 / GX24 system

Application

## module GX16

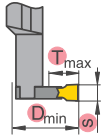

drawing illustrates right hand execution

details: page D29

## module GX24

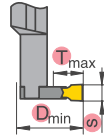

details: page D29

[inch]			type, ordering description
D <sub>min</sub>	s	T <sub>max</sub>	
1.57	.079 - .108	.354	MSS-I32R09-GX16-1
	.109 - .148		MSS-I32R09-GX16-2
	.148 - .197		<b>R</b> MSS-I32R09-GX16-3
	.197 - .256		MSS-I32R09-GX16-4
	.079 - .108	.354	MSS-I32L09-GX16-1
	.109 - .148		MSS-I32L09-GX16-2
	.148 - .197		<b>L</b> MSS-I32L09-GX16-3
	.197 - .256		MSS-I32L09-GX16-4
1.97	.079 - .108	.394	MSS-I40R10-GX16-1
	.109 - .148		MSS-I40R10-GX16-2
	.148 - .197		<b>R</b> MSS-I40R10-GX16-3
	.197 - .256		MSS-I40R10-GX16-4
	.079 - .108	.394	MSS-I40L10-GX16-1
	.109 - .148		MSS-I40L10-GX16-2
	.148 - .197		<b>L</b> MSS-I40L10-GX16-3
	.197 - .256		MSS-I40L10-GX16-4



[inch]			type, ordering description
D <sub>min</sub>	s	T <sub>max</sub>	
2.36	.109 - .148	.748	MSS-I40N19-GX24-2
	.148 - .197		MSS-I40N19-GX24-3
	.197 - .256		<b>N</b> MSS-I40N19-GX24-4
	.109 - .148	.748	MSS-I40N19-GX24-2
	.148 - .197		MSS-I40N19-GX24-3
	.197 - .256		<b>N</b> MSS-I40N19-GX24-4



<b>GX16</b>  details: page C9 - C10	<b>GX16R</b>  details: page C13
---	---------------------------------------

<b>GX24E</b>  details: page C11	<b>GX24R</b>  details: page C14
---------------------------------------	---------------------------------------

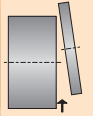

page B2-B15

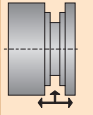

page B16-B23

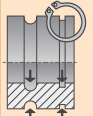

page B24-B49

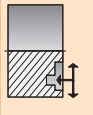

page B50-B59

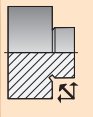

page B60-B65

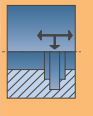

page B66-B77

### Turning

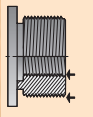

page B78-B93

### Milling

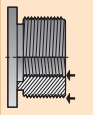

page B78-B93

# Thread turning Overview

TC16



page B81

**monobloc holder 0°**

**h / b**  $P = 0.5 - 3.0 \text{ mm}$   
 .500/.500  $T_{\text{max}} = .394$   $P = 48 - 8 \text{ TPI}$

TC16



page B82-B83

**shank 0°**

**h / b**  
 .625/.787 - 1.000/1.000

shank 90°

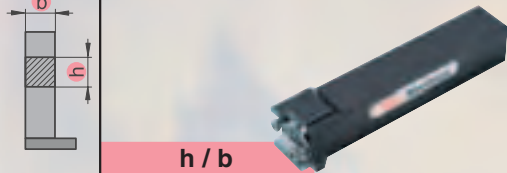

**h / b**  
 .750/.750 - 1.000/1.000

TC16



page B84-B85

**UTS 0°**

**d1**  
 40 - 63 mm

UTS 90°

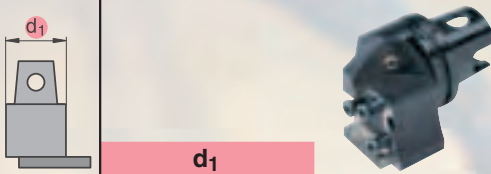

**d1**  
 40 - 50 mm

TC16



page B87

**monobloc boring bar**

$d_1 = .750 - 1.250$   
 $l_2 = 1.26 - 1.97$   
 $D_{\text{min}} = .79 - 1.26$   $P = 0.5 - 5.0 \text{ mm}$   
 $T_{\text{max}} = .157 - .236$   $P = 48 - 5 \text{ TPI}$

TC16



page B88-B89

**boring bar 1.5D**

$d_1 = 1.250$   
 $l_2 = 1.89$

boring bar 2.5D

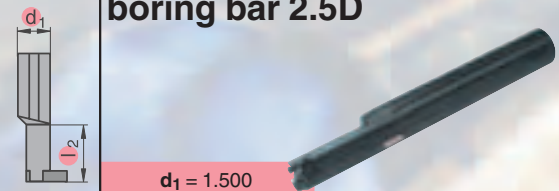

$d_1 = 1.500$   
 $l_2 = 3.15$

TC16



page B91

**UTS TC monobloc boring bar**

$d_1 = 40 - 50 \text{ mm}$   
 $l_2 = 1.26 - 1.97$   
 $D_{\text{min}} = .79 - 1.26$   $P = 0.5 - 5.0 \text{ mm}$   
 $T_{\text{max}} = .157 - .236$   $P = 48 - 5 \text{ TPI}$









TC16

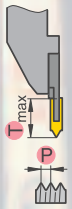

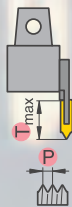
page B92-B93

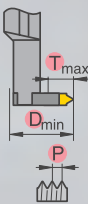
**UTS boring bar**

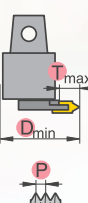
$d_1 = 40 - 50 \text{ mm}$   
 $l_2 = 2.52$

	<p><b>module TC16</b></p> <p><b>P = 0.5 - 5.0 mm</b>  <b>P = 48 - 5 TPI</b>  <b>T<sub>max</sub> = .315 - .472</b></p>	
	<p><b>module TC16</b></p> <p><b>P = 0.5 - 5.0 mm</b>  <b>P = 48 - 5 TPI</b>  <b>T<sub>max</sub> = .315 - .472</b></p>	
	<p><b>module TC16</b></p> <p><b>D<sub>min</sub> = 1.57</b>  <b>T<sub>max</sub> = .275</b>  <b>P = 0.5 - 5.0 mm</b>  <b>P = 48 - 5 TPI</b></p>	
	<p><b>module TC16</b></p> <p><b>D<sub>min</sub> = 1.57</b>  <b>T<sub>max</sub> = .275</b>  <b>P = 0.5 - 5.0 mm</b>  <b>P = 48 - 5 TPI</b></p>	

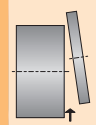

page B2-B15

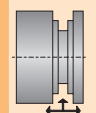

page B16-B23

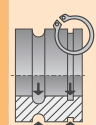

page B24-B49

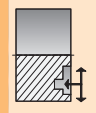

page B50-B59

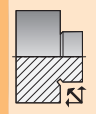

page B60-B65

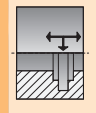

page B66-B77

**Turning**

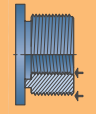

page B78-B93

**Milling**

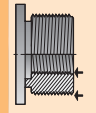

page B78-B93



TC16



page B81

TC16



page B82-B83

TC16



page B84-B85

TC16



page B87

TC16



page B88-B89

TC16



page B91

TC16



page B92-B93

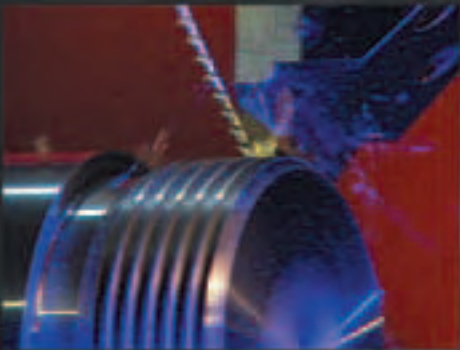

# Thread turning (external)

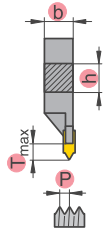

## Modular system (MSS)

### monobloc holder 0°



drawing illustrates right hand execution

details: page D30

Bgr.	[inch]			pitch "P"		type, ordering description
	h	b	T <sub>max</sub>	mm	T.P.I.	
E12	.500	.500	.394	0,5 - 1,5 1,75 - 3,0	48 - 16 14 - 8	 E12R00-08-TC16-E <b>R</b>
	.500	.500	.394	0,5 - 1,5 1,75 - 3,0	48 - 16 14 - 8	 E12L00-08-TC16-E <b>L</b>



ordering example: 1 piece E12R00-08-TC16-E

**60° partial profile  
(external & internal)**



details: page C24

**ISO 60°  
(external)**



details: page C26

**ISO 60°  
(internal)**



details: page C27

**Whitworth 55°  
(external & internal)**



details: page C28

Application

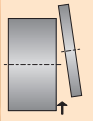

page B2-B15

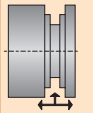

page B16-B23

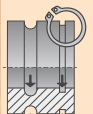

page B24-B49

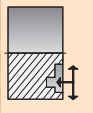

page B50-B59

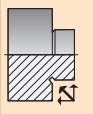

page B60-B65

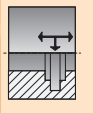

page B66-B77

#### Turning

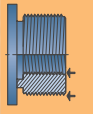

page B78-B93

#### Milling

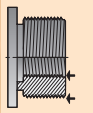

page B78-B93

# Thread turning (external)

## Modular system (MSS)

TC16



page B81

TC16



page B82-B83

TC16



page B84-B85

TC16



page B87

TC16



page B88-B89

TC16



page B91

TC16



page B92-B93

### shank 0°

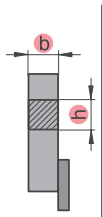

drawing illustrates right hand execution



details: page D2

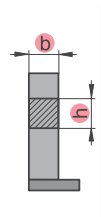

### shank 90°







drawing illustrates right hand execution

details: page D3

Bgr.	[inch]		type, ordering description
	h	b	
E20	.625	.787	 MSS-E20R00-10-E MSS-E20R00-12-E R
	.750	.750	
	.625	.787	 MSS-E20L00-10-E MSS-E20L00-12-E L
	.750	.750	

Bgr.	[inch]		type, ordering description
	h	b	
E20	.750	.750	 MSS-E20L90-12-E L
	.750	.750	
	.750	.750	 MSS-E20R90-12-E R
	.750	.750	

E25	1.000	1.000	 MSS-E25R00-16-E R
	1.000	1.000	
E25	1.000	1.000	 MSS-E25L00-16-E L
	1.000	1.000	

E25	1.000	1.000	 MSS-E25L90-16-E L
	1.000	1.000	
E25	1.000	1.000	 MSS-E25R90-16-E R
	1.000	1.000	

**ordering example:** 1 piece MSS-E20R00-12-E  
2 pieces MSS-E20N-TC16-2



attention in case of 90°:

right hand shank – left module  
left hand shank – right module





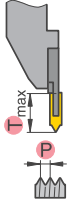



# TC16 system

## module TC 16







drawing illustrates right hand execution

details: page D32

pitch „P“		T <sub>max</sub>	type, ordering description
mm	T.P.I.		
0,5 - 1,5	48 - 16	.315	 MSS-E20R-TC16-1 <b>R</b>
1,75 - 3,0	14 - 8	.472	 MSS-E20N-TC16-2 <b>N</b>
0,5 - 1,5	48 - 16	.315	 MSS-E20L-TC16-1 <b>L</b>
1,75 - 3,0	14 - 8	.472	 MSS-E20N-TC16-2 <b>N</b>
0,5 - 1,5	48 - 16	.315	 MSS-E25R-TC16-1 <b>R</b>
1,75 - 3,0	14 - 8	.394	
3,5 - 5,0	7 - 5	.472	 MSS-E25N-TC16-3 <b>N</b>
0,5 - 1,5	48 - 16	.315	 MSS-E25L-TC16-1 <b>L</b>
1,75 - 3,0	14 - 8	.394	
3,5 - 5,0	7 - 5	.472	 MSS-E25N-TC16-3 <b>N</b>



<b>60° partial profile (external &amp; internal)</b>  details: page C24	<b>55° partial profile (external &amp; internal)</b>  details: page C25	<b>ISO 60° (external)</b>  details: page C26	<b>Whitworth 55° (external &amp; internal)</b>  details: page C28
--	--	--	--

## Application

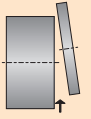

page B2-B15

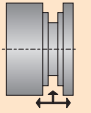

page B16-B23

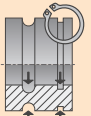

page B24-B49

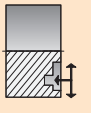

page B50-B59

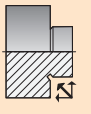

page B60-B65

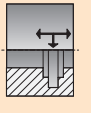

page B66-B77

### Turning

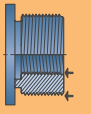

page B78-B93

### Milling

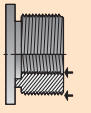

page B78-B93

# Thread turning (external) UTS (MSS)

TC16



page B81

TC16



page B82-B83

TC16



page B84-B85

TC16



page B87

TC16



page B88-B89

TC16



page B91

TC16



page B92-B93

## UTS 0°

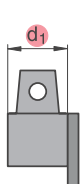

drawing illustrates right hand execution



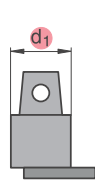

details: page D36





## UTS 90°



drawing illustrates right hand execution

details: page D37

Bgr.	[mm]	type, ordering description
	d <sub>1</sub>	
E25	40	 UT40-MSS-E25R00
	50	 UT50-MSS-E25R00
	63	<b>R</b> UT63-MSS-E25R00
	40	 UT40-MSS-E25L00
	50	 UT50-MSS-E25L00
	63	<b>L</b> UT50-MSS-E25L00

Bgr.	[mm]	type, ordering description
	d <sub>1</sub>	
E25	40	 UT40-MSS-E25L90
	50	 UT50-MSS-E25L90
	63	<b>L</b> UT63-MSS-E25L90
	40	 UT40-MSS-E25R90
	50	 UT50-MSS-E25R90
	63	<b>R</b> UT63-MSS-E25R90

**ordering example:** 1 piece UT50-MSS-E25R90  
2 pieces MSS-E25N-TC16-3



attention in case of 90°:

right hand UTS holder – left module  
left hand UTS holder – right module





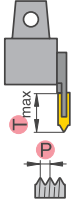

# TC16 system

## module TC16



drawing illustrates right hand execution

details: page D31

pitch, "P"		T <sub>max</sub>	type, ordering description
mm	T.P.I.		
0,5 - 1,5	48 - 16	.315	 MSS-E25R-TC16-1 MSS-E25R-TC16-2 <b>R</b>
1,75 - 3,0	14 - 8	.394	
3,5 - 5,0	7 - 5	.472	 MSS-E25N-TC16-3 <b>N</b>
0,5 - 1,5	48 - 16	.315	 MSS-E25L-TC16-1 MSS-E25L-TC16-2 <b>L</b>
1,75 - 3,0	14 - 8	.394	
3,5 - 5,0	7 - 5	.472	 MSS-E25N-TC16-3 <b>N</b>



**60° partial profile**  
(external & internal)



details: page C24

**55° partial profile**  
(external & internal)



details: page C25

**ISO 60°**  
(external)



details: page C26

**Whitworth 55°**  
(external & internal)



details: page C28

### Application

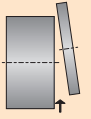

page B2-B15

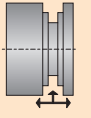

page B16-B23

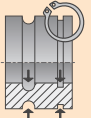

page B24-B49

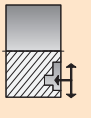

page B50-B59

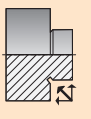

page B60-B65

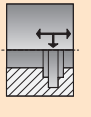

page B66-B77

#### Turning

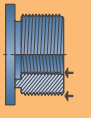

page B78-B93

#### Milling

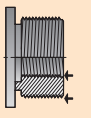

page B78-B93

# System

TC16



page B81

TC16



page B82-B83

TC16



page B84-B85

TC16



page B87

TC16



page B88-B89

TC16



page B91

TC16



page B92-B93



# Thread turning (internal)





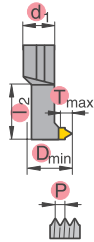

## Modular system (MSS)

### monobloc boring bar



drawing illustrates right hand execution

details: page D32

Bgr.	[inch]				pitch "P"		type, ordering description
	D <sub>min</sub>	l <sub>2</sub>	d <sub>1</sub>	T <sub>max</sub>	mm	T.P.I.	
16	.79	1.26	.750	.157	0,5 - 1,5 1,75 - 3,0	48 - 16 14 - 8	 I16R90-2D-TC16-E R
	.79	1.26	.750	.157	0,5 - 1,5 1,75 - 3,0	48 - 16 14 - 8	 I16L90-2D-TC16-E L
20	.98	1.57	1.000	.197	0,5 - 1,5 1,75 - 3,0 3,5 - 5,0	48 - 16 14 - 8 7 - 5	 I20R90-2D-TC16-E R
	.98	1.57	1.000	.197	0,5 - 1,5 1,75 - 3,0 3,5 - 5,0	48 - 16 14 - 8 7 - 5	 I20L90-2D-TC16-E L
25	1.26	1.97	1.250	.236	0,5 - 1,5 1,75 - 3,0 3,5 - 5,0	48 - 16 14 - 8 7 - 5	 I25R90-2D-TC16-E R
	1.26	1.97	1.250	.236	0,5 - 1,5 1,75 - 3,0 3,5 - 5,0	48 - 16 14 - 8 7 - 5	 I25L90-2D-TC16-E L

Bgr. = assembly size



ordering example: 1 piece I25R90-2D-TC16-E

**60° partial profile  
(external & internal)**



details: page C24

**55° partial profile  
(external & internal)**



details: page C25

**ISO 60°  
(internal)**



details: page C27

**Whitworth 55°  
(external & internal)**



details: page C28

Application

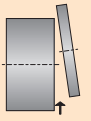

page B2-B15

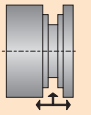

page B16-B23

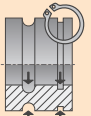

page B24-B49

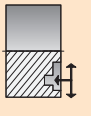

page B50-B59

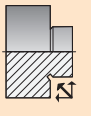

page B60-B65

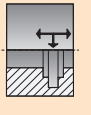

page B66-B77

#### Turning

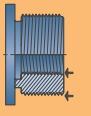

page B78-B93

#### Milling

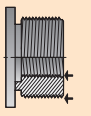

page B78-B93

# Thread turning (internal)

## Modular system (MSS)

TC16



page B81

TC16



page B82-B83

TC16



page B84-B85

TC16



page B87

TC16



page B88-B89

TC16



page B91

TC16



page B92-B93

### boring bar 1.5D

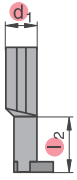

drawing illustrates right hand execution



details: page D24

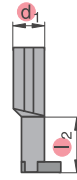

### boring bar 2.5D



drawing illustrates right hand execution

details: page D25

Bgr.	[inch]		type, ordering description
	l <sub>2</sub>	d <sub>1</sub>	
I32	1.89	1.250	 MSS-I32R90-1.5D-E
	1.89	1.250	 MSS-I32L90-1.5D-E

Bgr.	[inch]		type, ordering description
	l <sub>2</sub>	d <sub>1</sub>	
I32	3.15	1.500	 MSS-I32R90-2.5D-E
	3.15	1.500	 MSS-I32L90-2.5D-E

Bgr. = assembly size

**ordering example:** 1 piece MSS-I32R90-1.5D-E  
2 pieces MSS-I32R-TC16-1



# TC16 system

## module TC16

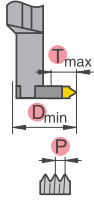

drawing illustrates right hand execution

details: page D33

[inch]		pitch "P"		type, ordering description
D <sub>min</sub>	T <sub>max</sub>	mm	T.P.I.	
1.57	.275	0,5 - 1,5	48 - 16	MSS-I32R-TC16-1
		1,75 - 3,0	14 - 8	MSS-I32R-TC16-2
		3,5 - 5,0	7 - 5	MSS-I32N-TC16-3
1.57	.275	0,5 - 1,5	48 - 16	MSS-I32L-TC16-1
		1,75 - 3,0	14 - 8	MSS-I32L-TC16-2
		3,5 - 5,0	7 - 5	MSS-I32N-TC16-3



<b>60° partial profile (external &amp; internal)</b>  details: page C24	<b>55° partial profile (external &amp; internal)</b>  details: page C25	<b>ISO 60° (internal)</b>  details: page C27	<b>Whitworth 55° (external &amp; internal)</b>  details: page C28
---	---	--	---

### Application

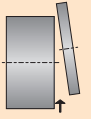

page B2-B15

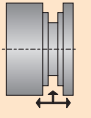

page B16-B23

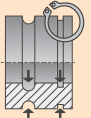

page B24-B49

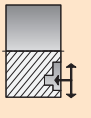

page B50-B59

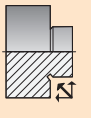

page B60-B65

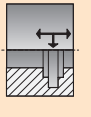

page B66-B77

#### Turning

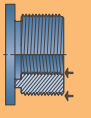

page B78-B93

#### Milling

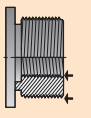

page B78-B93

# System

TC16



page B81

TC16



page B82-B83

TC16



page B84-B85

TC16



page B87

TC16



page B88-B89

TC16



page B91

TC16



page B92-B93





# Thread turning (internal) UTS (MSS)

Application

## UTS TC monobloc boring bar

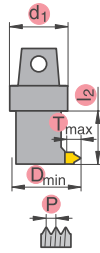

drawing illustrates right hand execution

details: page D40

Bgr.	[inch]				pitch "P"		type, ordering description
	D <sub>min</sub>	l <sub>2</sub>	d <sub>1</sub> mm	T <sub>max</sub>	mm	T.P.I.	
I16	.79	1.26	40	.157	0.5 - 1.5 1.75 - 3.0	48 - 16 14 - 8	UT40-MSS-I16R90-2D-TC16 <b>R</b>
	.79	1.26	40	.157	0.5 - 1.5 1.75 - 3.0	48 - 16 14 - 8	UT40-MSS-I16L90-2D-TC16 <b>L</b>
I20	.98	1.57	40	.197	0.5 - 1.5 1.75 - 3.0 3.5 - 5.0	48 - 16 14 - 8 7 - 5	UT40-MSS-I20R90-2D-TC16 <b>R</b>
	.98	1.57	40	.197	0.5 - 1.5 1.75 - 3.0 3.5 - 5.0	48 - 16 14 - 8 7 - 5	UT40-MSS-I20L90-2D-TC16 <b>L</b>
I25	1.26	1.97	40	.236	0.5 - 1.5 1.75 - 3.0 3.5 - 5.0	48 - 16 14 - 8 7 - 5	UT40-MSS-I25R90-2D-TC16 <b>R</b>
	1.26	1.97	40	.236	0.5 - 1.5 1.75 - 3.0 3.5 - 5.0	48 - 16 14 - 8 7 - 5	UT40-MSS-I25L90-2D-TC16 <b>L</b>

Bgr. = assembly size



ordering example: 1 piece UT40-MSS-I16L90-2D-TC16

**60° partial profile  
(external & internal)**



details: page C24

**55° partial profile  
(external & internal)**



details: page C25

**ISO 60°  
(internal)**



details: page C27

**Whitworth 55°  
(external & internal)**



details: page C28

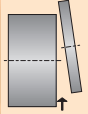

page B2-B15

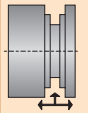

page B16-B23

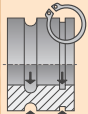

page B24-B49

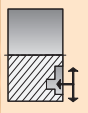

page B50-B59

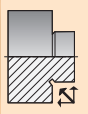

page B60-B65

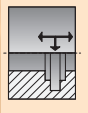

page B66-B77

### Turning

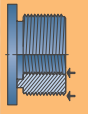

page B78-B93

### Milling

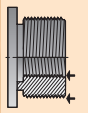

page B78-B93

# Thread turning (internal) UTS (MSS)

TC16



page B81

TC16



page B82-B83

TC16



page B84-B85

TC16



page B87

TC16



page B88-B89

TC16



page B91

TC16





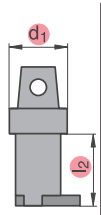

page B92-B93

## UTS boring bar



drawing illustrates right hand execution

details: page D39

Bgr.	[inch]	[mm]	type, ordering description
	l <sub>2</sub>	d <sub>1</sub>	
I32	2.52	40	 UT40-MSS-I32R90-2D
		50	 UT50-MSS-I32R90-2D
			<b>R</b>
	2.52	40	 UT40-MSS-I32L90-2D
50		 UT50-MSS-I32L90-2D	
		<b>L</b>	

Bgr. = assembly size

**ordering example:** 1 piece UT40-MSS-I32L90-2D  
2 pieces MSS-I32L-TC16-2

# TC16 system

## module TC16

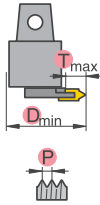

drawing illustrates right hand execution

details: page D33

[inch]		pitch "P"		type, ordering description
D <sub>min</sub>	T <sub>max</sub>	mm		
1.57	.275	0.5 - 1.5	48 - 16	MSS-I32R-TC16-1
		1.75 - 3.0	14 - 8	MSS-I32R-TC16-2 R
		3.5 - 5.0	7 - 5	MSS-I32N-TC16-3 N
1.57	.275	0.5 - 1.5	48 - 16	MSS-I32L-TC16-1
		1.75 - 3.0	14 - 8	MSS-I32L-TC16-2 L
		3.5 - 5.0	7 - 5	MSS-I32N-TC16-3 N



**60° partial profile  
(external & internal)**



details: page C24

**55° partial profile  
(external & internal)**



details: page C25

**ISO 60°  
(internal)**



details: page C27

**Whitworth 55°  
(external & internal)**



details: page C28

## Application

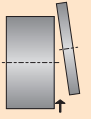

page B2-B15

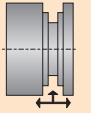

page B16-B23

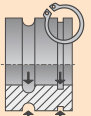

page B24-B49

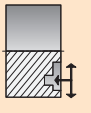

page B50-B59

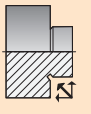

page B60-B65

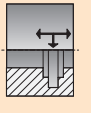

page B66-B77

### Turning

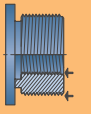

page B78-B93

### Milling

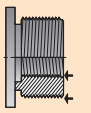

page B78-B93

# Thread milling Overview

TC16



page B96

TC16



page B97

TC16



page B98





TC16

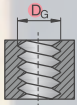

page B99

<b>internal</b>		<p><b>milling cutter</b></p> <p><math>D_N = .98 - 1.26</math>  <math>D_G = M27-M80</math> [mm]  <math>D_G = R1\frac{1}{4}-R2\frac{1}{2}</math> [inch]</p>
		<p><b>boring bars</b></p>
<b>external</b>		<p><b>milling cutter</b></p> <p><math>D_N = .98 - 1.26</math>  <math>D_G = M16-M80</math> [mm]  <math>D_G = R\frac{5}{8}-R1\frac{3}{4}</math> [inch]</p>
		<p><b>boring bars</b></p>

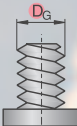
**Details chamfering see pages C29 and E36!**

	<p><b>module TC16</b></p>  <p><math>D_G = M82-M300</math> [mm]  <math>D_G = R2\frac{3}{4}-R6</math> [inch]</p>
	<p><b>module TC16</b></p>  <p><math>D_G = M82-M300</math> [mm]  <math>D_G = R2\frac{3}{4}-R6</math> [inch]</p>

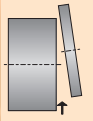

page B2-B15

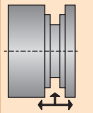

page B16-B23

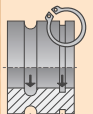

page B24-B49

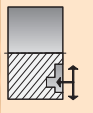

page B50-B59

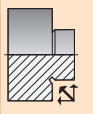

page B60-B65

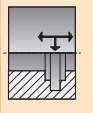

page B66-B77

**Turning**

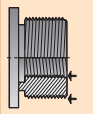

page B78-B93

**Milling**

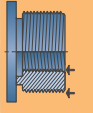

page B94-B99



# Thread milling (internal)

## Milling cutter system MSS-TC

TC16



page B96

TC16



page B97

TC16



page B98

TC16

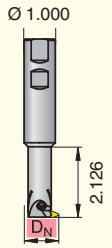
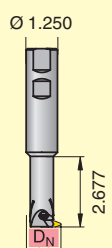

page B99

DN	type, ordering description
.98	I25R90-2D-TC16-W-E 
1.26	I32R90-2D-TC16-W-E 

DN = nominal milling Ø

 = standart thread

D <sub>G</sub> [mm]	full profile metric ISO 60° TC threading inserts										
	TC16-1   0,5 ISO	TC16-1   0,75 ISO	TC16-1   1,0 ISO	TC16-1   1,5 ISO	TC16-2   2,0 ISO	TC16-2   2,5 ISO	TC16-2   3,0 ISO	TC16-3   3,5 ISO	TC16-3   4,0 ISO	TC16-3   4,5 ISO	TC16-3   5,0 ISO
M27	x	x									
M28	x	x	x								
M30	x	x	x	x							
M32	x	x	x	x	x						
M33	x	x	x	x	x						
M34	x	x	x	x	x			x			
M35	x	x	x	x	x			x			
M36	x	x	x	x	x			x	x		
M38	x	x	x	x	x			x	x		
M39	x	x	x	x	x			x	x		
M40	x	x	x	x	x			x	x		
M42	x	x	x	x	x			x	x	x	
M45	x	x	x	x	x			x	x		
M48	x	x	x	x	x			x			x
M36	x	x	x								
M38	x	x	x	x							
M39	x	x	x	x	x						
M40	x	x	x	x	x						
M42	x	x	x	x	x			x			
M45	x	x	x	x	x			x			
M48	x	x	x	x	x			x			
M50	x	x	x	x	x			x	x		
M52		x	x	x	x			x	x		x
M55		x	x	x	x			x	x		
M56		x	x	x	x			x	x		
M58		x	x	x	x			x	x		
M60		x	x	x	x			x	x		
M62		x	x	x	x			x	x		
M64		x	x	x	x			x	x		
M65		x	x	x	x			x	x		
M68		x	x	x	x			x	x		
M70		x	x	x	x			x	x		
M72		x	x	x	x			x	x		
M75		x	x	x	x			x	x		
M76		x	x	x	x			x	x		
M78		x	x	x	x			x	x		
M80		x	x	x	x			x	x		

ISO 60° (internal)



details: page C27

D <sub>G</sub> [inch]	full profile Whitworth 55° TC threading inserts									
	TC16-2 EI 14W	TC16-2 EI 12W	TC16-2 EI 11W	TC16-2 EI 10W	TC16-2 EI 9W	TC16-2 EI 8W	TC16-3 EI 7W	TC16-3 EI 6W	TC16-3 EI 5W	
R1½			x							
1½										x
R1½			x							
1⅝										x
1¾										x
R2										
			x							
R2¼										
			x							
R2½										
			x							

Whitworth 55°



details: page C28

# Modular system MSS-TC

Application

	boring bar 1.5D	boring bar 2.5D
<b>Bgr.</b>	type, ordering description	type, ordering description
32	MSS-I32R90-1.5D-E  	MSS-I32R90-2.5D-E  

D <sub>G</sub> [mm]	full profile metric ISO 60°		
	module MSS-I32R-TC16-2 TC16-212,0 ISO	MSS-I32N-TC16-3 TC16-213,0 ISO	TC16-314,0 ISO
M82	x	x	x
M85	x	x	x
M90	x	x	x
M95	x	x	x
M100	x	x	x
M105	x	x	x
M110	x	x	x
M115	x	x	x
M120	x	x	x
M125	x	x	x
M130	x	x	x
M135	x	x	x
M140	x	x	x
M145	x	x	x
M150	x	x	x
M155		x	x
M160		x	x
M165		x	x
M170		x	x
M175		x	x
M180		x	x
M185		x	x
M190		x	x
M195		x	x
M200		x	x
M205		x	x
M210		x	x
M215		x	x
M220		x	x
M225		x	x
M230		x	x
M235		x	x
M240		x	x
M245		x	x
M250		x	x
↓		↓	↓
M300		x	x

D <sub>G</sub> [inch]	full profile Whitworth 55°
	module MSS-I32R-TC16-2 TC16-2 E1 11W
R2¾	x
R3	x
R3¼	x
R3½	x
R3¾	x
R4	x
R4½	x
R5	x
R5½	x
R6	x

Bgr. = assembly size

ISO 60° (internal)



details: page C27

Whitworth 55°



details: page C28

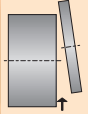

page B2-B15

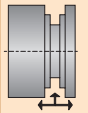

page B16-B23

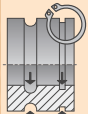

page B24-B49

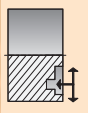

page B50-B59

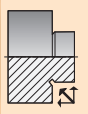

page B60-B65

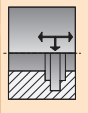

page B66-B77

**Turning**

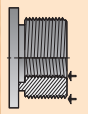

page B78-B93

**Milling**

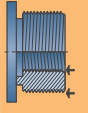

page B94-B99

# Thread milling (external)

## Milling cutter system MSS-TC

TC16



page B96

TC16



page B97

TC16



page B98

TC16



page B99

<b>DN</b>	
	<b>type, ordering description</b>
.98	I25R90-2D-TC16-W-E
1.26	I32R90-2D-TC16-W-E
Ø 1.000 / Ø 1.250  2.126 / 2.677	

DN = nominal milling Ø

D <sub>G</sub> [mm]	full profile metric ISO 60° TC - threading inserts										
	TC16-1 E 0,5 ISO	TC16-1 E 0,75 ISO	TC16-1 E 1,0 ISO	TC16-1 E 1,5 ISO	TC16-2 E 2,0 ISO	TC16-2 E 2,5 ISO	TC16-2 E 3,0 ISO	TC16-3 E 3,5 ISO	TC16-3 E 4,0 ISO	TC16-3 E 4,5 ISO	TC16-3 E 5,0 ISO
↓											
M16											
↓											
↓											
↓											
↓											
M80											

External threads in the range between M16 and M80 can be milled with both tools, I25.. or I32..  
Choose the adequate threading inserts with the required pitch.

ISO 60° external



details: page C26

D <sub>G</sub> [inch]	full profile whitworth 55° TC - threading inserts									
	TC16-2 EI 14W	TC16-2 EI 12W	TC16-2 EI 11W	TC16-2 EI 10W	TC16-2 EI 9W	TC16-2 EI 8W	TC16-3 EI 7W	TC16-3 EI 6W	TC16-3 EI 5W	
↓										
5/8			x							
3/4				x						
7/8					x					
1						x				
1 1/8							x			
1 3/8								x		
1 1/2									x	
1 5/8										x
1 3/4										x



Whitworth 55°



details: page C28

# Modular system MSS-TC

Application

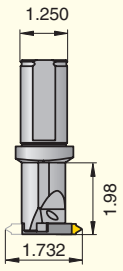
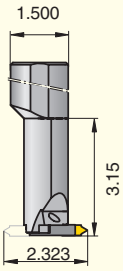
	boring bar 1.5D	boring bar 2.5D
		
<b>Bgr.</b>	<b>type, ordering description</b>	<b>type, ordering description</b>
32	MSS-I32R90-1.5D-E 	MSS-I32R90-2.5D-E 

module	full profile metric ISO 60°	
	MSS-I32R-TC16-2	MSS-I32N-TC16-3
D <sub>G</sub> [mm]	TC16-2E2,0/ISO	TC16-3E4,0/ISO
M82	x	x
M85	x	x
M90	x	x
M95	x	x
M100	x	x
M105	x	x
M110	x	x
M115	x	x
M120	x	x
M125	x	x
M130	x	x
M135	x	x
M140	x	x
M145	x	x
M150	x	x
M155		x
M160		x
M165		x
M170		x
M175		x
M180		x
M185		x
M190		x
M195		x
M200		x
M205		x
M210		x
M215		x
M220		x
M225		x
M230		x
M235		x
M240		x
M245		x
M250		x
↓		↓
M300		x

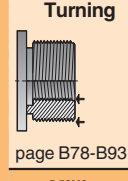
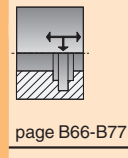
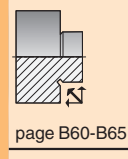
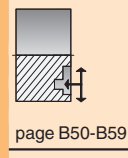
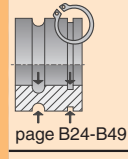
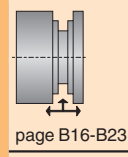
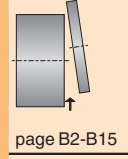

Bgr. = assembly size

**ISO 60°  
(external)**



details: page C26







# Inserts Overview

Inserts

FX	LX	GX	GX	GX	GMS	TC
						
<b>s = .087</b>  page C2	<b>s = .315</b>  page C7	<b>s = .077 - .138</b>  page C8	<b>s = .024 - .067</b>  page C16	<b>s = .063 - .094</b>  page C20	<b>s = .118</b>  page C23	<b>Partial profile 60° external and internal</b>  page C24
<b>s = .122</b>  page C3		<b>s = .079 - .138</b>  page C9	<b>s = .077 - .128</b>  page C17	<b>s = .063 - .197</b>  page C21		<b>Partial profile 55° external and internal</b>  page C25
<b>s = .161</b>  page C4		<b>s = .157 - .236</b>  page C10	<b>s = .024 - .088</b>  page C18	<b>s = .118 - .315</b>  page C22		<b>Full profile metr. 60° external</b>  page C26
<b>s = .201 - .256</b>  page C5		<b>s = .118 - .236</b>  page C11	<b>s = .108 - .207</b>  page C19			<b>Full profile metr. 60° internal</b>  page C27
<b>s = .323 - .382</b>  page C6		<b>s = .079 - .094</b>  page C12				<b>Full profile external and internal</b>  page C28
		<b>s = .118 - .236</b>  page C13				<b>Chamfering insert external and internal</b>  page C29
		<b>s = .118 - .315</b>  page C14				

FX  
page C2 - C6

LX  
  
page C7

GX  
  
page C8 - C14

GX  
  
page C16 - C19

GX  
  
page C20 - C22

GMS  
  
page C23

TC  
  
page C24 - C29

# Parting inserts

## FX system

s = .087



page C2

s = .122



page C3

s = .161



page C4

s = .201 - .256



page C5

s = .323 - .382



page C6

Application									
-------------	--	--	--	--	--	--	--	--	--

### parting width .087 inch

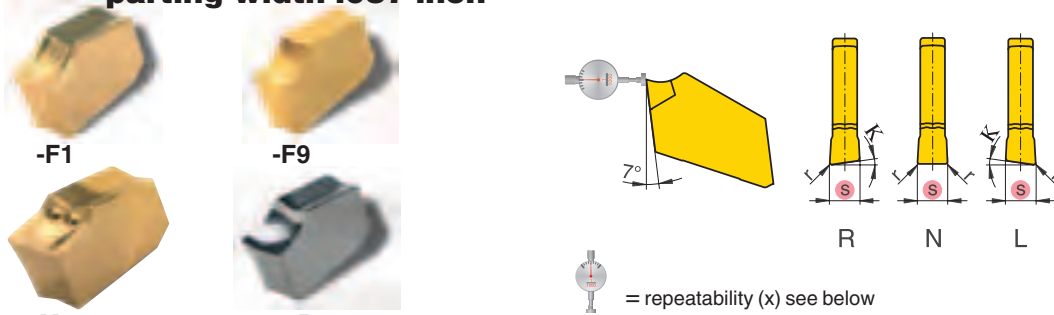

= repeatability (x) see below

S	type, ordering description	designation up to now	K [°]	r [inch]	hardness ← toughness →							
					H216 T	SR127	SR735	GM40	S40 T	GMT40	SM80	
.087	N	FX 2.2N0.15-F1	0	.006	●	●				●		
		FX 2.2N0.10-F9		LEMX 22FN	.004						●	
		FX 2.2N0.10-M1		LEMX 22SN-FX	.004	●	●	●	●	●		
		FX 2.2N0.10-27P		LEMX 22FN-FX-27P	.004	●						
	L	FX 2.2L5-F1		5	.006		●			●		
		FX 2.2L4-F9	LEMX 22FL	4	.004						●	
		FX 2.2L4-M1	LEMX 22SL-FX	4	.004	●	●	●	●			
	R	FX 2.2R5-F1		5	.006		●			●		
		FX 2.2R4-F9	LEMX 22FR	4	.004						●	
		FX 2.2R4-M1	LEMX 22SR-FX	4	.004	●	●	●	●			
	width 2,2		x	s	r							
	-F1 / -27P		±.0051	-.0039	±.0020	Steel	●	●	●	●	●	●
-M1 / -F9		±.0051	-.0039	±.0020	Stainless	○		○		●	●	
					Cast iron	○	●	●	●	●	●	
					Non ferrous metals	●	●	●	●	○	●	

● = International TIZIT range, for present availability see price list

ordering example: 30 pieces FX 2.2N0.10-27P H 216 T

You can find application recommendations on page E8 - E13!

tools / modules	FX	FX	FX						
see page	D8/9	D10/11	D41						

# Parting inserts

## FX system

Inserts

Application									
-------------	--	--	--	--	--	--	--	--	--

parting width .122 inch

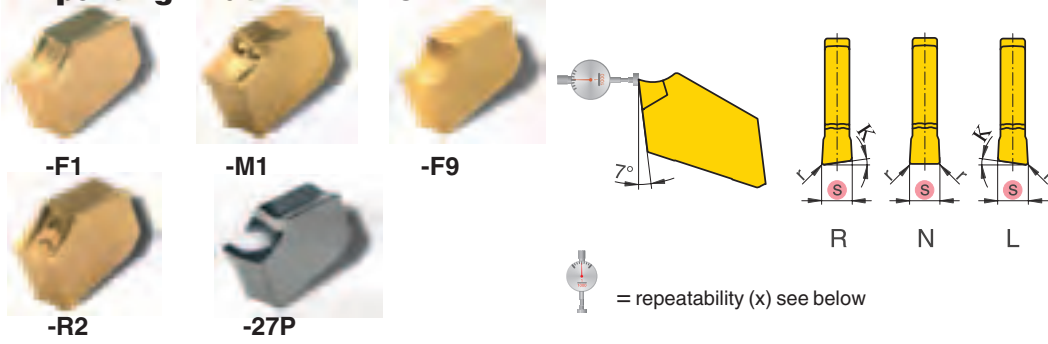

S	type, ordering description	designation up to now	K [°]	r [inch]	hardness ← toughness →							
					H216 T	SR127	SR735	GM40	S40 T	GM740	SM80	
.122	N	FX 3.1N0.20-F1	0	.008	●	●				●		
		FX 3.1N0.40-F1		.016	●	●				●		
		FX 3.1N0.15-F9		LFMX 31FN	.006						●	
		FX 3.1N0.15-M1		LFMX 31SN-FX	.006	●	●	●	●	●		
		FX 3.1N0.40-R2			.016	●	●				●	
		FX 3.1N0.15-27P		LFMX 31FN-FX-27P	.006	●						
	L	FX 3.1L5-F1		5	.008		●			●		
		FX 3.1L8-F1		8	.008					●		
		FX 3.1L6-F9	LFMX 31FL	6	.006						●	
	R	FX 3.1R5-F1		5	.008		●			●		
		FX 3.1R8-F1		8	.008					●		
		FX 3.1R6-F9	LFMX 31FR	6	.006						●	
	FX 3.1R6-M1	LFMX 31SR-FX	6	.006	●	●	●	●				
width 3,1		tolerances			Steel	●	●	●	●	●	●	
	x	s	r	Stainless	○	○			●	●		
-F1 / -27P / -F9	±.0051	-.0039	±.0020	Cast iron	●	●						
-M1 / -R2	±.0051	-.0039	±.0020	Non ferrous metals	●				○			

FX



page C2 - C6

LX



page C7

GX



page C8 - C14

GX



page C16 - C19

GX



page C20 - C22

GMS



page C23

TC



page C24 - C29

You can find application recommendations on page E8 - E13!

tools / modules	FX	FX	FX					
see page	D8/9	D10/11	D41					

# Parting inserts

## FX System

s = .087



page C2

s = .122



page C3

s = .161



page C4

s = .201 - .256



page C5

s = .323 - .382



page C6

Application									
-------------	--	--	--	--	--	--	--	--	--

parting width .161 inch

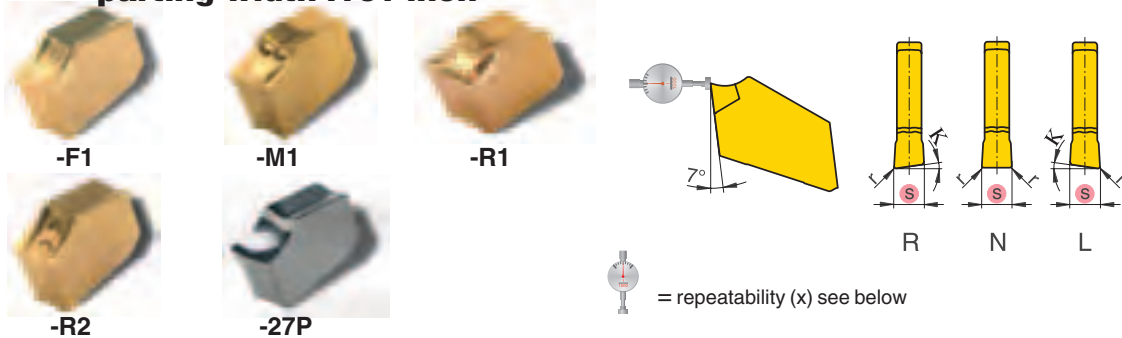

= repeatability (x) see below

S	type, ordering description	designation up to now	K [°]	r [inch]	hardness				toughness		
					H216 T	SR127	SR735	GM40	S40 T	GM740	SM80
.161	N	FX 4.1N0.20-F1	0	.008	●	●			●		
		FX 4.1N0.50-F1		.020	●	●			●		
		FX 4.1N0.20-M1		LFMX 41SN-FX	.008	●	●	●	●	●	
		FX 4.1N0.20-R1			.008			●			
		FX 4.1N0.50-R2			.020	●	●			●	
		FX 4.1N0.15-27P		LFMX 41FN-FX-27P	.006	●					
	L	FX 4.1L5-F1		5	.008		●			●	
		FX 4.1L8-F1		8	.008					●	
	R	FX 4.1R5-F1		5	.008		●			●	
		FX 4.1R8-F1		8	.008					●	
FX 4.1R6-M1		LFMX 41SR-FX	6	.008	●	●	●				
width 4,1		tolerances			Steel		●	●	●	●	●
	x	s	r	Stainless		○	○	○	○	○	
	±.0051	-.0039	±.0020	Cast iron		○	○	○	○	○	
	±.0051	-.0039	±.0020	Non ferrous metals		○	○	○	○	○	

● = International TIZIT range, for present availability see price list

ordering example: 30 pieces FX 4.1R5-F1 Sr735





You can find application recommendations on page E8 - E13!

tools / modules	FX	FX	FX						
see page	D8/9	D10/11	D41						

# Parting inserts

## FX System

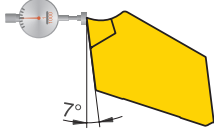
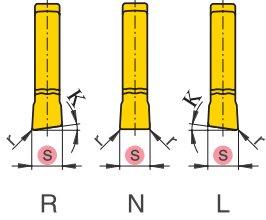
Inserts

Application											
<b>parting width .201 / .256 inch</b>											
		 -M1		 -R1		 7°		 R N L		 = repeatability (x) see below	
S	type, ordering description	designation up to now	K [°]	r [inch]	hardness ← toughness →						
					H216 T	SR127	SR735	GM40	S40 T	GM740	SM80
.201	N	FX 5.1N0.25-M1	LFMX 51SN-FX	0	.010	●	●	●	●	●	
	L	FX 5.1L6-M1	LFMX 51SL-FX	6	.010	●	●				
.256	N	FX 6.5N0.30-M1	LFMX 65SN-FX	0	.012	●	●	●		●	
		FX 6.5N0.30-R1			.012			●			
		FX 6.5N0.50-R1			.012					●	
		FX 6.5N0.80-R1			.031			●			
	L	FX 6.5L6-M1	LFMX 65SL-FX	6	.012	●					
R	FX 6.5R4-R1		4	.020					●		
width 5,1 / 6,5		tolerances			 Steel: ● ● ● ● ● ● ● ● Stainless: ○ ○ ○ ● ● ● Cast iron: ● ● ● ● ● ● ● ● Non ferrous metals: ● ● ● ● ● ○						
-M1	x	s	r								
-R1	±.0051	-.0059	±.0020								
				±.0051	-.0059	±.0039					

FX  
  
 page C2 - C6

LX  
  
 page C7

GX  
  
 page C8 - C14

GX  
  
 page C16 - C19

GX  
  
 page C20 - C22

GMS  
  
 page C23

TC  
  
 page C24 - C29

You can find application recommendations on page E8 - E13!

tools / modules	FX	FX						
								
see page	D10/11	D41						



# Parting inserts

## FX system

s = .087



page C2

s = .122



page C3

s = .161



page C4

s = .201 - .256



page C5

s = .323 - .382



page C6

s = .315



page C7

Application									
-------------	--	--	--	--	--	--	--	--	--

parting width .323 / .382 inch



-M1

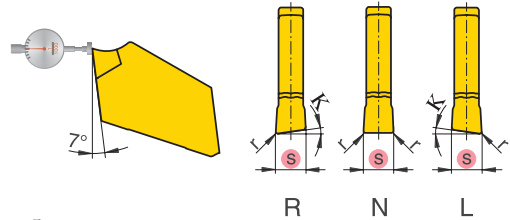

= repeatability (x) see below

S	type, ordering description	designation up to now	K [°]	r [inch]	hardness		toughness				
					H216T	SR127	SR735	GM40	S40T	GMT40	SM80
.323	N FX 8.2N0.40-M1	LEMX 82SN-FX	0	.016	●	●			●		
.382	N FX 9.7N0.40-M1	LEMX 97SN-FX	0	.016	●	●					
tolerances											
width 8,2 / 9,7											
		x	s	r	Steel	●	●	●	●	●	●
	-M1	±.0059	-.0079	±.0039	Stainless	○	○	○	○	○	○
					Cast iron	●	●	●	●	●	●
					Non ferrous metals	●	●	●	○	○	○

● = International TIZIT range, for present availability see price list

ordering example: 30 pieces FX 8.2N0.40-M1 Sr 127

You can find application recommendations on page E8 - E13!

tools / modules	FX 								
see page	D41								

# Parting and grooving inserts

## LX system

Inserts

Application

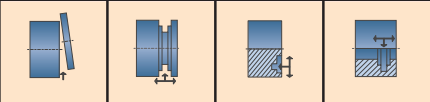

**parting and grooving width .315 inch**

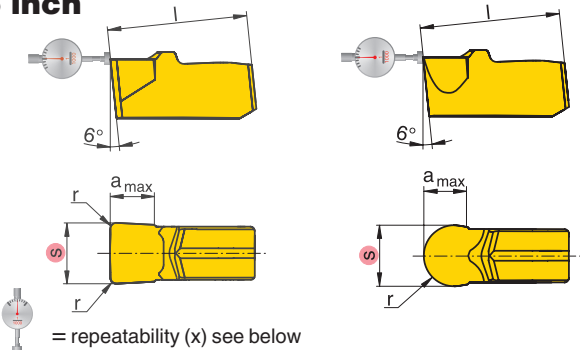
-M2                      -M3

= repeatability (x) see below

S	type, ordering description	[inch]			hardness ← toughness →							
		l	r	a <sub>max</sub>	AMZ	H216T	TSM20	SR127	GM127	SR735	GM40	GM740
.315	LX E8.00N0.80-M2	.75	.031	.197				●		●		
.315	LX R4.00N-M3	.75	.157	.197				●		●		
tolerances		x	s	r	Steel ○							
LX		±.0059	±.0031	±.0039	Stainless ○							
					Cast iron ●							
					Non ferrous metals ●							

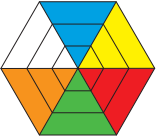

FX  
page C2 - C6

LX  
page C7

GX  
page C8 - C14

GX  
page C16 - C19

GX  
page C20 - C22

GMS  
page C23

TC  
page C24 - C29

You can find application recommendations on page E24!

tools / modules	LX 	LX 						
see page	D21	D43						

# Grooving inserts GX09 system

Width

s = .077 - .138



GX09

page C8

s = .079 - .138



GX16

page C9

s = .157 - .236



GX16

page C10

s = .118 - .236



GX24

page C11

s = .079 - .094



GX09

page C12

s = .118 - .236



GX16

page C13

s = .118 - .315



GX24

page C14

Application									
-------------	--	--	--	--	--	--	--	--	--

grooving width .077 - .138 inch



standard



circlip



-M4

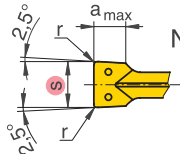
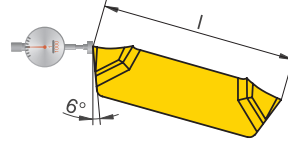

= repeatability (x) see below

s	type, ordering description	[inch]			hardness		toughness					
		l	r	a <sub>max</sub>	AMZ	H216T	TSM20	SR127	GMT27	SR735	GM40	GM740
.077	GX09-1S1.95N	.354	.004	.060				●				
.079	GX09-1E2.00N0.20		.008	.060				●	●			
	GX09-1E2.00N0.20-M4		.008	.060				●		●		●
.088	GX09-1S2.25N		.004	.060				●				
.098	GX09-1E2.50N0.20		.008	.060				●	●			
.108	GX09-2S2.75N		.004	.079				●				
.118	GX09-2E3.00N0.30		.012	.079				●	●			
	GX09-2E3.00N0.30-M4		.012	.079				●		●		●
.128	GX09-2S3.25N		.004	.079				●				
.138	GX09-2E3.50N0.30		.012	.079				●	●			
tolerances												
GX09-E / S / -27P		x	s	r								
-M4		±.0008	±.0008	±.0020								
		±.0039	±.0020	±.0020								

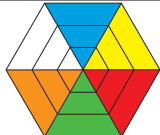

● = International TIZIT range, for present availability see price list

ordering example: 30 pieces GX09-2E3.00N0.30 Gm 127

You can find application recommendations on page E14 - E23!

tools / modules	GX09	GX09	GX09	GX09				
see page	D14	D6	D28	D23				

# Grooving inserts GX16 system

Inserts

Application									
-------------	--	--	--	--	--	--	--	--	--

**parting and grooving width .079 - .138 inch**

standard  
-M4

circlip  
-27P

= repeatability (x) see below

S	type, ordering description	[inch]			hardness		toughness					
		l	r	a <sub>max</sub>	AMZ	H216T	TSM20	SR127	GM127	SR735	GM40	GM740
.079	GX16-1E2.00N0.20	.63	.008	.098				●	●			
	GX16-1E2.00N0.20-M4		.008	.098			●		●		●	
	GX16-1E2.00N0.20-27P		.008	.098	●							
.098	GX16-1E2.50N0.20		.008	.098				●	●			
	.108		GX16-2S2.75N	.004	.118			●				
.118			GX16-2E3.00N0.30	.012	.118			●	●			
	GX16-2E3.00N0.50		.020	.118			●					
	GX16-2E3.00N0.30-M4		.012	.118			●		●		●	
.128	GX16-2S3.25N		.004	.118				●				
.138	GX16-2E3.50N0.30		.012	.118				●	●			

tolerances				Steel	Stainless	Cast iron	Non ferrous metals
	x	s	r				
GX16-.E / S / -27P	±.0008	±.0008	±.0020				
-M4	±.0059	±.0020	±.0020	○	○	○	○

You can find application recommendations on page E14 - E23!

tools / modules	GX16	GX16						
see page	D15	D29						

- FX page C2 - C6
- LX page C7
- GX page C8 - C14
- GX page C16 - C19
- GX page C20 - C22
- GMS page C23
- TC page C24 - C29

# Parting and grooving inserts

## GX16 system

s = .077 - .138



GX09

page C8

s = .079 - .138



GX16

page C9

s = .157 - .236



GX16

page C10

s = .118 - .236



GX24

page C11

s = .079 - .094



GX09

page C12

s = .118 - .236



GX16

page C13

s = .118 - .315



GX24

page C14

Application									
-------------	--	--	--	--	--	--	--	--	--

### parting and grooving width .157 - .236 inch



standard

circlip

-M4

-27P

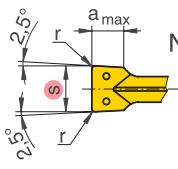
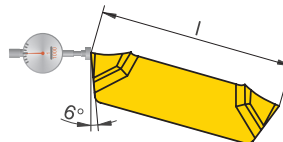

= repeatability (x) see below

S	type, ordering description	l	[inch]			hardness ← toughness									
			r	a <sub>max</sub>		AMZ	H216T	TSM20	SR127	GMT27	SR735	GM40	GM740		
.157	GX16-3E4.00N0.40	.63	.016	.138					●	●					
	GX16-3E4.00N0.60		.024	.138					●						
	GX16-3E4.00N0.40-M4		.016	.157					●		●		●		
	GX16-3E4.00N0.40-27P		.016	.138		●									
.167	GX16-3S4.25N		.008	.138					●						
.177	GX16-3E4.50N0.40		.016	.138					●						
.197	GX16-3E5.00N0.40		.016	.138					●	●					
	GX16-3E5.00N0.60		.024	.138					●						
	GX16-3E5.00N0.40-M4		.016	.157					●		●		●		
	GX16-4S5.25N		.008	.157					●						
.207	GX16-4E6.00N0.50		.020	.157					●	●					
	GX16-4E6.00N0.80		.031	.157					●						
	GX16-4E6.00N0.50-M4	.020	.177					●		●		●			
	GX16-4E6.00N0.50-27P	.020	.157					●							
tolerances					Steel										
					Stainless										
					Cast iron										
					Non ferrous metals										
		x	s	r											
GX16-S / E / -27P		±.0008	±.0008	±.0020											
-M4		±.0059	±.0020	±.0020											

● = International TIZIT range, for present availability see price list

ordering example: 30 pieces GX16-E6.00N0.80 Sr 127

You can find application recommendations on page E14 - E23!

tools / modules	GX16	GX16							
see page	D15	D29							



# Parting and grooving inserts GX24 system

Inserts

Application									
-------------	--	--	--	--	--	--	--	--	--

parting and grooving width .118 - .236 inch



standard



-F2



-27P

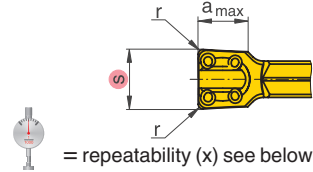
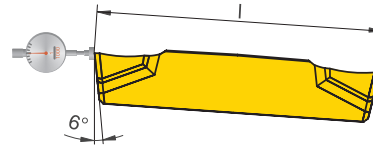

S	type, ordering description	[inch]			hardness				toughness						
		l	r	a <sub>max</sub>	AMZ	H216T	TSM20	SR127	GM127	SR735	GM40	GM740			
.118	GX24-2E3.00N0.30	.94	.012	.098				●			●				
	GX24-2E3.00N0.30-F2		.012	.098				●		●		●			
	GX24-2E3.00N0.30-27P		.012	.098		●									
.138	GX24-2E3.50N0.30-F2		.012	.098				●		●		●			
	GX24-3E4.00N0.40		.016	.118				●		●		●			
.157	GX24-3E4.00N0.40-F2		.016	.118				●		●		●			
	GX24-3E4.00N0.40-27P		.016	.118		●									
.177	GX24-3E4.50N0.40-F2		.016	.118				●		●		●			
	GX24-3E5.00N0.40		.016	.118				●		●		●			
.197	GX24-3E5.00N0.40-F2		.016	.138				●		●		●			
	GX24-3E5.00N0.40-27P		.016	.138		●									
	GX24-4E6.00N0.50		.020	.138				●		●		●			
.236	GX24-4E6.00N0.50-F2		.020	.157				●		●		●			
	GX24-4E6.00N0.50-27P		.020	.157		●									
tolerances															
	x	s	r												
GX24-.E...	±.0071	±.0020	±.0020												
-F2 / -27P	±.0008	±.0008	±.0020												

FX



page C2 - C6

LX



page C7

GX



page C8 - C14

GX



page C16 - C19

GX



page C20 - C22

GMS



page C23

TC



page C24 - C29

You can find application recommendations on page E14 - E23!

tools / modules	GX24 	GX24 axial 	GX24 	GX24 				
see page	D16	D17-20	D42	D29				

C11

# Grooving inserts

## GX09 system - radius inserts

Width

s = .077 - .138



GX09

page C8

s = .079 - .138



GX16

page C9

s = .157 - .236



GX16

page C10

s = .118 - .236



GX24

page C11

s = .079 - .094



GX09

page C12

s = .118 - .236



GX16

page C13

s = .118 - .315



GX24

page C14

Application												
<b>grooving width .079 / .094 inch</b>												
 <b>standard</b>		<p>= repeatability (x) see below</p>										
<b>S</b>	type, ordering description	[inch]				← hardness		toughness →				
		l	r	a <sub>max</sub>	AMZ	H216T	TSM 20	SR127	GMT27	SR735	GM40	GM740
.079	N	GX09-1R1.00N		.354	.039	.039		●	●			
.094		GX09-1R1.20N			.047	.047		●	●			
<b>tolerances</b>		x	s	r								
GX09-1R...		±.0008	±.0008	±.0020								

● = International TIZIT range, for present availability see price list

ordering example: 30 pieces GX09-1R1.00N Sr 127



You can find application recommendations on page E14 - E23!

tools / modules	GX09	GX09	GX09	GX09				
see page	D14	D6	D28	D23				

# Grooving inserts

## GX16 system - radius inserts

Inserts

Application								
-------------	---	---	---	--	--	--	--	--

**grooving width .118 - .236 inch**



standard



-27P

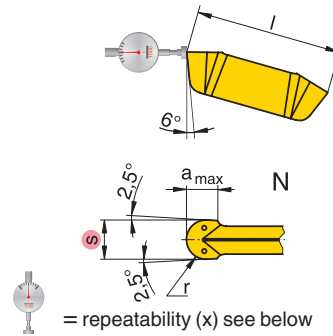

S	type, ordering description	[inch]			hardness		toughness					
		l	r	a <sub>max</sub>	AMZ	H216T	TSM20	SR127	GM127	SR735	GM40	GM740
.118	GX16-2R1.50N	.63	.059	.059				●	●			
	GX16-2R1.50N-27P		.059	.059		●						
.157	GX16-3R2.00N		.079	.079				●	●			
	GX16-3R2.00N-27P		.079	.079			●					
.197	GX16-3R2.50N		.098	.098				●	●			
	GX16-3R2.50N-27P		.098	.098			●					
.236	GX16-4R3.00N	.118	.118				●	●				

tolerances																
	x	s	r		Steel	Stainless	Cast iron	Non ferrous metals	AMZ	H216T	TSM20	SR127	GM127	SR735	GM40	GM740
GX16-.R / -27P	±.0008	±.0008	±.0020		●	●	●	●	●	●	●	●	●	●	●	●

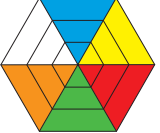
FX



page C2 - C6

LX



page C7

GX



page C8 - C14

GX



page C16 - C19

GX



page C20 - C22

GMS



page C23

TC



page C24 - C29

**You can find application recommendations on page E14 - E23!**

tools / modules	GX16 	GX16 						
see page	D15	D29						

# Grooving inserts

## GX24 system - radius inserts

Width

s = .077 - .138



GX09

page C8

s = .079 - .138



GX16

page C9

s = .157 - .236



GX16

page C10

s = .118 - .236



GX24

page C11

s = .079 - .094



GX09

page C12

s = .118 - .236



GX16

page C13

s = .118 - .315



GX24

page C14

Application									
-------------	--	--	--	--	--	--	--	--	--

grooving width .118 - .315 inch



-M3



-27P

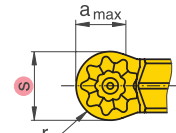
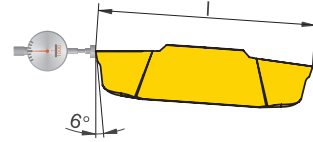

= repeatability (x) see below

S	type, ordering description	[inch]			hardness				toughness			
		l	r	a <sub>max</sub>	AMZ	H216T	TSM20	SR127	GMT27	SR735	GM40	GM740
.118	GX24-2R1.50N-M3	.94	.059	.059				●	●			
.157	GX24-3R2.00N-M3		.079	.098				●	●			
.197	GX24-3R2.50N-M3		.098	.118				●	●			
.236	GX24-4R3.00N-M3	1.01	.118	.138				●	●			
.236	GX24-4R3.00N-27P		.118	.157			●					
.315	GX24-5R4.00N-27P		.157	.197			●					
tolerances					Steel							
		x	s	r	Stainless							
	-27P	±.0008	±.0008	±.0020	Cast iron							
	-M3	±.0071	±.0020	±.0020	Non ferrous metals							

● = International TIZIT range, for present availability see price list

ordering example: 30 pieces GX24-4R3.00N-27P TSM 20

You can find application recommendations on page E14 - E23!

tools / modules								
see page	D16	D17-20	D42	D29				



**FX**



page C2 - C6

**LX**



page C7

**GX**



page C8 - C14

**GX**



page C16 - C19

**GX**



page C20 - C22

**GMS**



page C23

**TC**



page C24 - C29



# Grooving inserts

## GX09 system circlip R / L

Width

s = .024 - .067



GX09 R/L  
page C16

s = .077 - .128



GX09 N  
page C17

s = .024 - .088



GX16 R/L  
page C18

s = .108 - .207



GX16 N  
page C19

Application									
-------------	--	--	--	--	--	--	--	--	--

groove width .024 - .067 inch



circlip R/L

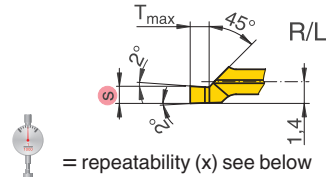
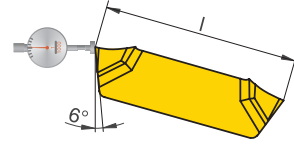

S	DIN 471- 472		type, ordering description	[inch]			hardness				toughness								
	S <sub>1</sub>	S <sub>2</sub>		l	r	T <sub>max</sub>	AMZ	H216T	TSM20	SR127	GMT27	SR735	GM40	GM740					
.024	.016	.020	R	GX09-1S0.60R	.35	—	.029				●								
.031	.024	.027		GX09-1S0.80R			.037						●						
.035	.027	.031		GX09-1S0.90R			.041						●						
.039	.031	.035		GX09-1S1.00R			.045						●						
.047	.039	.043		GX09-1S1.20R			.053						●						
.055	.047	.051		GX09-1S1.40R			.060						●						
.067	.059	.063		GX09-1S1.70R			.072						●						
.024	.016	.020		L			GX09-1S0.60L			.029				●					
.031	.024	.027	GX09-1S0.80L				.037						●						
.035	.027	.031	GX09-1S0.90L				.041						●						
.039	.031	.035	GX09-1S1.00L				.045						●						
.047	.039	.043	GX09-1S1.20L				.053						●						
.055	.047	.051	GX09-1S1.40L				.060						●						
.067	.059	.063	GX09-1S1.70L				.072						●						
tolerances							Steel ○												
							Stainless ○												
							Cast iron ○												
							Non ferrous metals ○												
GX09-1S			x	s	r														
			±.0008	±.0008	±.0020														

● = International TIZIT range, for present availability see price list



ordering example: 30 pieces GX09-1S1.40L Sr 127

You can find application recommendations on page E14 - E23!

tools / modules	GX09	GX09	GX09	GX09					
see page	D12	D6	D26	D23					

# Grooving inserts GX09 system circlip N

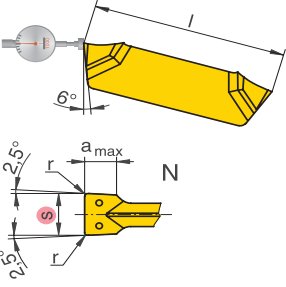
Inserts

Application																		
<p><b>groove width .077 - .128 inch</b></p> <p><b>circlip N</b></p>   <p>= repeatability (x) see below</p>																		
			[inch]			hardness		toughness										
DIN 471-472		type, ordering description		l	r	a <sub>max</sub>	AMZ	H216T	TSM20	SR127	GM127	SR735	GM40	GM740				
S	S <sub>1</sub>	S <sub>2</sub>		.35	.004	.079												
.077	.069	.073					GX09-1S1.95N											
.088	.079	.085					GX09-1S2.25N											
.108	.098	.104					GX09-2S2.75N											
.128	.118	.124	GX09-2S3.25N															
tolerances						Steel												
GX09 S			x	s	r	Stainless												
			±.0008	±.0008	±.0020	Cast iron												
						Non ferrous metals												



**DIN 471 - 472:** DIN standard for circlip grooves  
**s:** width of grooving inserts  
**s<sub>1</sub>:** circlip width  
**s<sub>2</sub>:** standard groove width H13 (+0,14 / 0)

You can find application recommendations on page E14 - E23!

tools / modules	GX09	GX09	GX09	GX09				
see page	D14	D6	D28	D23				

FX



page C2 - C6

LX



page C7

GX



page C8 - C14

GX



page C16 - C19

GX



page C20 - C22

GMS



page C23

TC



page C24 - C29

# Grooving inserts

## GX16 system circlip R / L

Width

s = .024 - .067



**GX09 R/L**  
page C16

s = .077 - .128



**GX09 N**  
page C17

s = .024 - .088



**GX16 R/L**  
page C18

s = .108 - .207



**GX16 N**  
page C19

Application									
-------------	--	--	--	--	--	--	--	--	--

grooving width .024 - .088 inch



circlip R / L

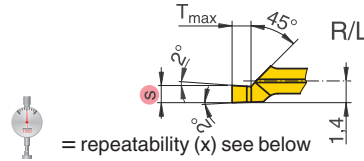
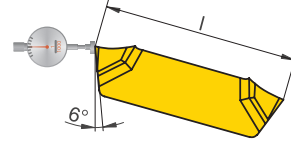

= repeatability (x) see below

S	DIN 471- 472		type, ordering description	[inch]			hardness ← toughness											
	S <sub>1</sub>	S <sub>2</sub>		l	r	T <sub>max</sub>	AMZ	H216T	TSM20	SR127	GMT27	SR735	GM40	GM740				
.024	.016	.020	R	GX16-2S0.60R	.63	—	.029				●							
.031	.024	.027		GX16-2S0.80R			.037			●								
.035	.027	.031		GX16-2S0.90R			.041			●								
.039	.031	.035		GX16-2S1.00R			.045			●								
.047	.039	.043		GX16-2S1.20R			.053			●								
.055	.047	.051		GX16-2S1.40R			.060			●								
.067	.059	.063		GX16-2S1.70R			.072			●								
.077	.069	.073		GX16-2S1.95R			.081			●								
.088	.079	.085		GX16-2S2.25R			.093			●								
.024	.016	.020		L			GX16-2S0.60L	.63	—	.029				●				
.031	.024	.027	GX16-2S0.80L		.037					●								
.035	.027	.031	GX16-2S0.90L		.041					●								
.039	.031	.035	GX16-2S1.00L		.045					●								
.047	.039	.043	GX16-2S1.20L		.053					●								
.055	.047	.051	GX16-2S1.40L		.060					●								
.067	.059	.063	GX16-2S1.70L		.072					●								
.077	.069	.073	GX16-2S1.95L		.081					●								
.088	.079	.085	GX16-2S2.25L		.093					●								

tolerances			
	x	s	r
GX 16	±.0008	±.0008	±.0020

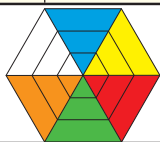

Steel	●	●	●	●	●	●	●	●	●	●	●	●	●	●	●	●
Stainless	○	○	○	○	○	○	○	○	○	○	○	○	○	○	○	○
Cast iron	○	○	○	○	○	○	○	○	○	○	○	○	○	○	○	○
Non ferrous metals	●	●	●	●	●	●	●	●	●	●	●	●	●	●	●	●

● = International TIZIT range, for present availability see price list

ordering example: 30 pieces GX16-2S1.20L Sr 127

You can find application recommendations on page E14 - E23!

tools / modules	<b>GX16</b> 	<b>GX16</b> 							
see page	D13	D27							

# Parting and grooving inserts

## GX16 system circlip N

Inserts

**Application**

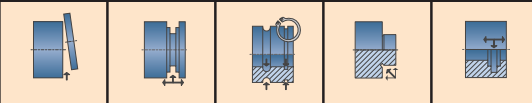

**parting and grooving width .108 - .207 inch**

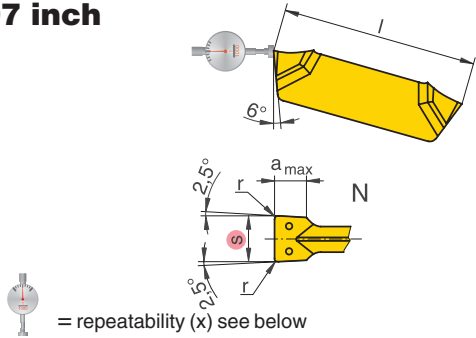
**circlip N**

S	DIN 471-472		type, ordering description	[inch]			hardness ← toughness									
	S <sub>1</sub>	S <sub>2</sub>		l	r	a <sub>max</sub>	AMZ	H216T	TSM20	SR127	GM127	SR735	GM40	GM740		
.108	.098	.104	 GX16-2S2.75N GX16-2S3.25N GX16-3S4.25N GX16-4S5.25N	.63	.004	.118					●					
.128	.118	.124			.004	.118						●				
.167	.157	.163			.008	.138						●				
.207	.197	.203			.008	.157						●				
tolerances																
GX 16			x	s	r											
			±.0008	±.0008	±.0020											



**FX**  
page C2 - C6

**LX**  
page C7

**GX**  
page C8 - C14

**GX**  
page C16 - C19

**GX**  
page C20 - C22

**GMS**  
page C23

**TC**  
page C24 - C29

You can find application recommendations on page E14 - E23!

<b>tools / modules</b>	<b>GX16</b> 	<b>GX16</b> 						
<b>see page</b>	D15	D29						

# Grooving inserts

## GX09 system radius inserts R / L / N

Width

s = .063 - .094



GX09

page C20

s = .063 - .197



GX16

page C21

s = .118 - .315



GX24

page C22

Application														
<b>grooving width .063 - .094 inch</b>														
 radius insert R		 radius insert N		<p style="text-align: center;">= repeatability (x) see below</p>										
<b>S</b>	<b>type, ordering description</b>	<b>[inch]</b>				<b>hardness ← toughness</b>								
		<b>l</b>	<b>r</b>	<b>T<sub>max</sub></b>	<b>a<sub>max</sub></b>	<b>AMZ</b>	<b>H216T</b>	<b>TSM20</b>	<b>SR127</b>	<b>GMT127</b>	<b>SR735</b>	<b>GM40</b>	<b>GM740</b>	
.063	R  GX09-1R0.80R	.35	.031	.070					●					
.063	L  GX09-1R0.80L		.031	.070					●					
.079	N  GX09-1R1.00N		.039			.039				●	●			
.094	N  GX09-1R1.20N		.047			.047				●	●			
<b>tolerances</b>														
		<b>x</b>	<b>s</b>	<b>r</b>	 Steel ● Stainless ○ Cast iron ○ Non ferrous metals ●									
GX 09 R		±.0008	±.0008	±.0020										

● = International TIZIT range, for present availability see price list

**ordering example:** 30 pieces GX09-1R1.00N Gm 127

**You can find application recommendations on page E14 - E23!**









tools / modules	GX09	GX09	GX09	GX09				
<b>see page</b>	D 12/14	D26/28	D6	D23				

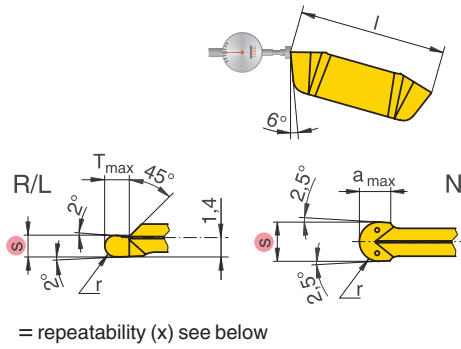

# Grooving inserts

## GX16 system radius inserts R / L / N

Inserts

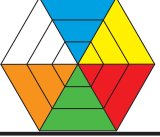
Application													
<b>grooving width .063 - .197 inch</b>													
 radius insert R		 radius insert N											
 radius insert -27P													
<b>S</b>	type, ordering description	[inch]				hardness ← toughness							
		l	r	T <sub>max</sub>	a <sub>max</sub>	AMZ	H216T	TSM20	SR127	GMT27	SR735	GM40	GMT40
.063		GX16-2R0.80R	.031	.070				●					
.079		GX16-2R1.00R	.039	.086				●					
.094		GX16-2R1.20R	.047	.101				●					
.063		GX16-2R0.80L	.031	.070				●					
.079		GX16-2R1.00L	.039	.086				●					
.094		GX16-2R1.20L	.047	.101				●					
.118		GX16-2R1.50N	.059		.059			●	●				
.118		GX16-2R1.50N-27P	.059		.059		●						
.157		GX16-3R2.00N	.079		.079			●	●				
.157		GX16-3R2.00N-27P	.079		.079		●						
.197		GX16-3R2.50N	.098		.098			●	●				
.197	GX16-3R2.50N-27P	.098		.098		●							
<b>tolerances</b>													
GX16 R / -27P	x	s	r										
	±.0008	±.0008	±.0020										
				Steel	●	●	●	●	●	●	●	●	●
				Stainless	●	●	●	●	●	●	●	●	●
				Cast iron	●	●	●	●	●	●	●	●	●
				Non ferrous metals	●	●	●	●	●	●	●	●	●

FX



page C2 - C6

LX



page C7

GX



page C8 - C14

GX



page C16 - C19

GX



page C20 - C22

GMS



page C23

TC



page C24 - C29

You can find application recommendations on page E14 - E23!

tools / modules	GX16	GX16						
								
see page	D 13/15	D27/29						

C21

# Grooving inserts GX24 system radius inserts N

s = .063 - .094



GX09

page C20

s = .063 - .197



GX16

page C21

s = .118 - .315



GX24

page C22

s = .118



GmS

page C23

Application																
<b>grooving width .118 - .315 inch</b>																
											= repeatability (x) see below					
S	type, ordering description	[inch]			hardness				toughness							
		l	r	a <sub>max</sub>	AMZ	H216T	TSM20	SR127	GMT27	SR735	GM40	GM740				
.118	GX24-2R1.50N-M3	.94	.059	.059				●	●							
.157	GX24-3R2.00N-M3		.079	.098				●	●							
.197	GX24-3R2.50N-M3		.098	.118				●	●							
.236	GX24-4R3.00N-M3	1.01	.118	.138				●	●							
.236	GX24-4R3.00N-27P		.118	.157				●								
.315	GX24-5R4.00N-27P		.157	.197				●								
<b>tolerances</b>					Steel							Steel				
					x	s	r	Stainless							Stainless	
-27P					±.0008	±.0008	±.0020	Cast iron							Cast iron	
-M3		±.0071	±.0020	±.0020	Non ferrous metals							Non ferrous metals				

● = International TIZIT range, for present availability see price list

ordering example: 30 pieces GX24-4R3.00N-27P TSM 20

You can find application recommendations on page E14 - E23!

tools / modules	GX24	GX24 axial	GX24	GX24					
see page	D16	D18-20	D42	D29					

# Parting inserts

## GMS system

Inserts

Application									
-------------	---	--	--	--	--	--	--	--	--

parting width .118 inch



standard

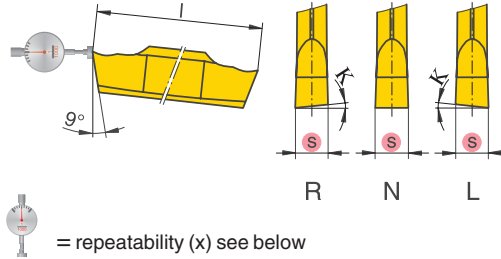

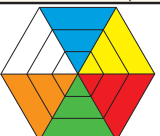
S	type, ordering description	l [inch]	K [°]	r [inch]	hardness ← toughness							
					H216T	TSM20	SR127	GM127	SR735	GM40	GM740	GMS
.118	LDMX 30FN	1.087	0	-								●
.118	LDMX 30FR		7	-								●
.118	LDMX 30FL		7	-								●
tolerances					Steel	●	●	●	●	●	●	●
	x				s	Stainless	●	●	●	●	●	●
LDMX	±.0039	+.0039			Cast iron	●	●	●	●	●	●	●
					Non ferrous metals	●	●	●	●	●	●	●

● = International TIZIT range, for present availability see price list

ordering example: 30 pieces LDMX 30 FN GmS

tools / modules	GmS 								
see page	D7								

FX



page C2 - C6

LX



page C7

GX



page C8 - C14

GX



page C16 - C19

GX



page C20 - C22

GMS



page C23

TC



page C24 - C29

# Threading inserts TC

## Partial profile 60° (external and internal)

Partial profile 60° external and internal  
page C24

Partial profile 55° external and internal  
page C25

Full profile metr. 60° external  
page C26

Full profile metr. 60° internal  
page C27

Full profile Whitw. 55° external and internal  
page C28

Chamfering insert external and internal  
page C29

Application									
-------------	---	--	--	--	--	--	--	--	--

**pitch P: 0.5 - 5.0 mm**  
**48 - 5 T.P.I.**



standard



-27P

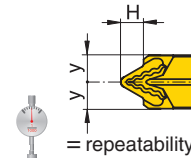
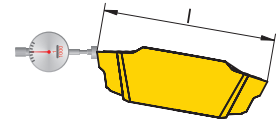
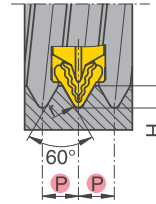
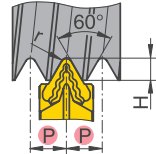





= repeatability (x) see below

pitch P		type, ordering description	[inch]				H216T	GM213	GM240
mm	T.P.I.		l	H	r	y			
0.5 - 1.5	48 - 16	TC16-1 EI-A60	.63	.050	.0012	.041	●	●	●
		TC16-1 EI-A60-27P					●		
1.75 - 3.0	14 - 8	TC16-2 EI-G60		.098	.0043	.085	●	●	●
		TC16-2 EI-G60-27P					●		
0.5 - 3.0	48 - 8	TC16-2 EI-AG60		.010	.0012	.085	●	●	●
		TC16-2 EI-AG60-27P					●		
3.5 - 5.0	7 - 5	TC16-3 EI-N60		.162	.0087	.122	●	●	●
		TC16-3 EI-N60-27P					●		
tolerances						Steel	●	●	●
x						Stainless	○	○	○
TC16...	±.0008				Cast iron	○	○	○	
					Non ferrous metals	●	●	●	

● = International TIZIT range, for present availability see price list

ordering example: 30 pieces TC16-3 EI-N60-27P H 216 T

tools / modules	TC	TC	TC	TC	UTS TC			
								
see page	D30	D31	D33	D32	D40			

# Threading inserts TC

## Partial profile 55° (external and internal)

Inserts

Application	Turning 								
-------------	---	--	--	--	--	--	--	--	--

pitch P: 0.5 - 5.0 mm  
48 - 5 T.P.I.



standard

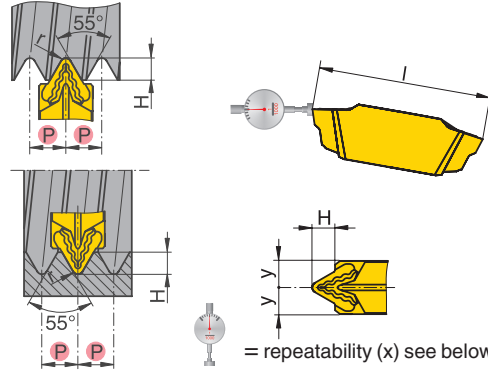

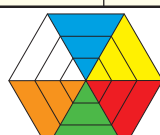
pitch P		type, ordering description	l	[inch]			H216T	GM213	GM240
mm	TP.I.			H	r	y			
0.5 - 1.5	48 - 16	TC16-1 EI-A55	.63	.055	.005	.041		●	●
1.75 - 3.00	14 - 8,0	TC16-2 EI-G55		.109	.009	.085		●	●
0.5 - 3.0	48 - 8,0	TC16-2 EI-AG55		.114	.005	.085		●	●
3.5 - 5.0	7 - 5	TC16-3 EI-N55		.171	.018	.122		●	●
tolerances		x		Steel			●	●	●
TC16...	±.0008			Stainless			○	○	○
				Cast iron			○	○	○
				Non ferrous metals			●	●	●

● = International TIZIT range, for present availability see price list

ordering example: 30 pieces TC16-1 EI-A55 Gm 240

FX  
  
page C2 - C6

LX  
  
page C7





GX  
  
page C8 - C14

GX  
  
page C16 - C19

GX  
  
page C20 - C22

GMS  
  
page C23

TC  
  
page C24 - C29

tools / modules	TC 	TC 	TC 	TC 	UTS TC 			
see page	D30	D31	D33	D32	D40			



# Threading inserts TC

## Full profile metric ISO 60° (external)

Partial profile 60° external and internal  
page C24

Partial profile 55° external and internal  
page C25

Full profile metr. 60° external  
page C26

Full profile metr. 60° internal  
page C27

Full profile Whitw. 55° external and internal  
page C28

Chamfering insert external and internal  
page C29

Application	Turning	Milling						
-------------	---------	---------	--	--	--	--	--	--

pitch P: 0.5 - 5.0 mm

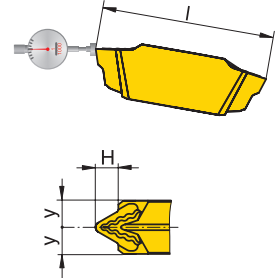
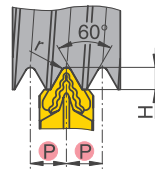

= repeatability (x) see below

pitch P mm	type, ordering description	[inch]				H216T	GM213	GM240
		l	H	r	y			
0.5	TC16-1 E 0,5 ISO	.63	.012	.002	.041	●	●	●
	TC16-1 E 0,5 ISO-27P		●	●		●		
0.75	TC16-1 E 0,75 ISO		.019	.003		●	●	●
	TC16-1 E 0,75 ISO-27P		●	●		●		
1.0	TC16-1 E 1,0 ISO		.025	.005	●	●	●	
	TC16-1 E 1,0 ISO-27P		●	●	●			
1.25	TC16-1 E 1,25 ISO		.031	.006	●	●	●	
	TC16-1 E 1,25 ISO-27P		●	●	●			
1.5	TC16-1 E 1,5 ISO		.037	.007	●	●	●	
	TC16-1 E 1,5 ISO-27P		●	●	●			
1.75	TC16-2 E 1,75 ISO		.043	.009	●	●	●	
	TC16-2 E 1,75 ISO-27P		●	●	●			
2.0	TC16-2 E 2,0 ISO		.050	.010	●	●	●	
	TC16-2 E 2,0 ISO-27P		●	●	●			
2.5	TC16-2 E 2,5 ISO		.062	.012	●	●	●	
	TC16-2 E 2,5 ISO-27P		●	●	●			
3.0	TC16-2 E 3,0 ISO	.074	.015	●	●	●		
	TC16-2 E 3,0 ISO-27P	●	●	●				
3.5	TC16-3 E 3,5 ISO	.087	.017	.122	●	●	●	
4.0	TC16-3 E 4,0 ISO	.100	.020		●	●	●	
4.5	TC16-3 E 4,5 ISO	.112	.022		●	●	●	
5.0	TC16-3 E 5,0 ISO	.124	.025		●	●	●	

tolerances	
x	
TC16...	±.0008

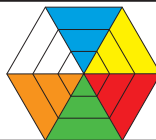



Steel	●	●	●
Stainless	○	○	○
Cast iron	○	○	○
Non ferrous metals	●	●	●

tools / modules	TC	TC	TC milling					
see page	D30	D31	D35					

# Threading inserts TC

## Full profile metric ISO 60° (internal)

Inserts

Application	Turning 	Milling 							
-------------	---	---	--	--	--	--	--	--	--

pitch P: 0.5 - 5.0 mm



standard



-27P

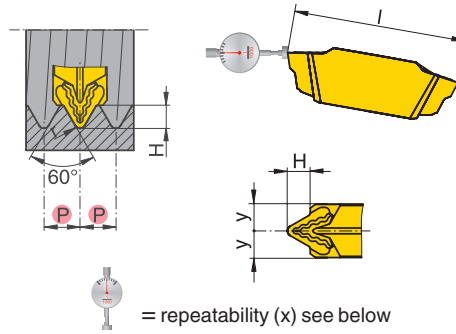

pitch P mm	type, ordering description	[inch]				H216T	GM213	GM240	
		l	H	r	y				
0.5	TC16-1   0.5 ISO	.63	.012	.001	.041		●	●	
0.75	TC16-1   0.75 ISO		.018	.001			●	●	
1.0	TC16-1   1.0 ISO		.023	.002		●		●	
	TC16-1   1.0 ISO-27P								
1.25	TC16-1   1.25 ISO		.029	.003				●	●
1.5	TC16-1   1.5 ISO		.035	.003				●	●
1.5	TC16-1   1.5 ISO-27P				●				
1.75	TC16-2   1.75 ISO		.040	.004	.085		●	●	
2.0	TC16-2   2.0 ISO		.046	.005		●		●	●
	TC16-2   2.0 ISO-27P								
2.5	TC16-2   2.5 ISO		.057	.006				●	●
3.0	TC16-2   3.0 ISO		.069	.007		●		●	
	TC16-2   3.0 ISO-27P								
3.5	TC16-3   3.5 ISO		.081	.009	.122		●	●	
4.0	TC16-3   4.0 ISO		.092	.010				●	●
4.5	TC16-3   4.5 ISO		.104	.011				●	●
5.0	TC16-3   5.0 ISO	.115	.012				●	●	



  

tolerances		Steel	Stainless	Cast iron	Non ferrous metals
TC16...	x				
	±.0008	●	○	○	●



● = International TIZIT range, for present availability see price list

ordering example: 30 pieces TC16-3 | 5,0 ISO Gm 213

tools / modules	TC 	TC 	TC milling 	UTSTC 				
see page	D33	D32	D35	D40				

FX



page C2 - C6

LX



page C7

GX



page C8 - C14

GX



page C16 - C19

GX



page C20 - C22

GMS



page C23

TC



page C24 - C29

# Threading inserts TC

## Full profile whitworth 55° (external and internal)

Partial profile 60° external and internal  
page C24

Partial profile 55° external and internal  
page C25

Full profile metr. 60° external  
page C26

Full profile metr. 60° internal  
page C27

Full profile Whitw. 55° external and internal  
page C28

Chamfering insert external and internal  
page C29

Application	Turning	Milling						
-------------	---------	---------	--	--	--	--	--	--

**pitch P: 0.5 - 5.0 mm**  
**28 - 5 T.P.I.**



standard



-27P

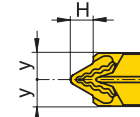
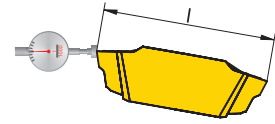
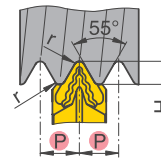
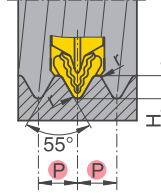

= repeatability (x) see below

pitch P T.P.I.	type, ordering description	[inch]				H216T	GM213	GM240	
		l	H	r	y				
28	TC16-1 EI 28 W	.63	.024	.005	.041		●	●	
26	TC16-1 EI 26 W		.025	.005			●	●	
24	TC16-1 EI 24 W		.027	.005			●	●	
20	TC16-1 EI 20 W		.033	.007				●	●
19	TC16-1 EI 19 W-27P		.035	.007			●		
	TC16-1 EI 19 W		.035	.007				●	●
18	TC16-1 EI 18 W		.037	.007			●	●	
16	TC16-1 EI 16 W		.041	.008			●	●	
14	TC16-2 EI 14 W-27P		.047	.009	.085	●			
	TC16-2 EI 14 W							●	●
12	TC16-2 EI 12 W		.055	.011				●	●
11	TC16-2 EI 11 W-27P		.060	.012			●		
	TC16-2 EI 11 W							●	●
10	TC16-2 EI 10 W		.066	.013				●	●
9	TC16-2 EI 9 W		.074	.014			●	●	
8	TC16-2 EI 8 W		.083	.016			●	●	
7	TC16-3 EI 7 W	.095	.018	.122		●	●		
6	TC16-3 EI 6 W	.111	.021				●	●	
5	TC16-3 EI 5 W	.133	.025				●	●	

tolerances	
	x
TC16...	±.0008

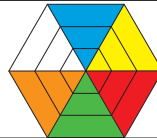

Steel	●	●	●
Stainless	○	○	○
Cast iron	○	○	○
Non ferrous metals	●	●	●



● = International TIZIT range, for present availability see price list

ordering example: 30 pieces TC16-2EI14W-27P H 216 T

tools / modules	TC	TC	TC	TC	TC milling	UTS TC		
see page	D30	D31	D33	D32	D35	D40		

# Chamfering insert

Inserts

Application	Turning 	Milling 							
-------------	---	---	--	--	--	--	--	--	--



chamfering insert

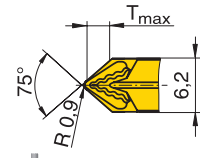
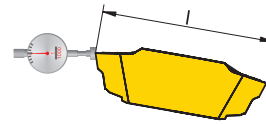

 = repeatability (x) see below

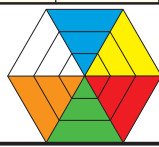
type, ordering description	[inch]				H216T	GM213	GM240
	l	s	R	T <sub>max</sub>			
TC 16-3-75	.64	.244	.035	.098		●	
tolerances		x	s	r			
TC16...	±.0059	-	±.0020				
					Steel	●	●
					Stainless	○	●
					Cast iron	○	●
					Non ferrous metals	●	●

● = International TIZIT range, for present availability see price list

ordering example: 30 pieces TC16-3-75 GM213

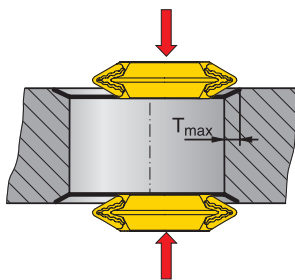

FX  
  
page C2 - C6

LX  
  
page C7







GX  
  
page C8 - C14

GX  
  
page C16 - C19

GX  
  
page C20 - C22

GMS  
  
page C23

TC  
  
page C24 - C29





tools / modules	TC 	TC 	TC 	TC 	TC milling 	UTS TC 		
see page	D30	D31	D33	D32	D35	D40		



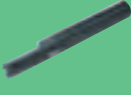

# Tools Overview

Tools

						
<b>MSS 0°</b>	<b>FX short</b>	<b>GX mono</b>	<b>GX09</b>	<b>TC mono</b>	<b>UTS 0°</b>	<b>FX</b>
 page D2	 page D10	 page D23	 page D26	 page D30	 page D36	 page D41
<b>MSS 90°</b>	<b>FX long</b>	<b>1.5 x D</b>	<b>GX16</b>	<b>TC16</b>	<b>UTS 90°</b>	<b>GX</b>
 page D3	 page D11	 page D24	 page D27	 page D31	 page D37	 page D42
<b>MSS 45°</b>	<b>GX09</b>	<b>2.5 x D</b>	<b>GX09</b>	<b>TC mono</b>	<b>UTS 45°</b>	<b>LX</b>
 page D4	 page D12	 page D25	 page D28	 page D32	 page D38	 page D43
<b>Adapter</b>	<b>GX16</b>		<b>GX16 / 24</b>	<b>TC16</b>	<b>UTS GX</b>	<b>SBN...K</b>
 page D5	 page D13		 page D29	 page D33	 page D39	 page D44
<b>GX mono</b>	<b>GX09</b>			<b>TC milling</b>	<b>UTS TC</b>	<b>SBN...KS</b>
 page D6	 page D14			 page D35	 page D40	 page D45
<b>GMS</b>	<b>GX16</b>					
 page D7	 page D15					
<b>FX mono</b>	<b>GX24</b>					
 page D8 - D9	 page D16					
	<b>GX axial</b>					
	 page D17 - D20					
	<b>LX</b>					
	 page D21					

## Shanks



page D2-D10

## External modules



page D10-D21

## Boring bars



page D23-D25

## Internal modules



page D26-D29

## Threading



page D30-D35

## UTS



page D36-D40

## Block - blade

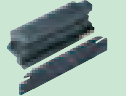

page D41-D45



# Tools

## Modular system (MSS)

MSS - 0°



page D2

MSS - 90°



page D3

MSS - 45°



page D4

Adapter



page D5

GX mono



page D6

GMS



page D7

FX mono



page D8-D9

Application					Turning				
-------------	--	--	--	--	---------	--	--	--	--

shank 0°

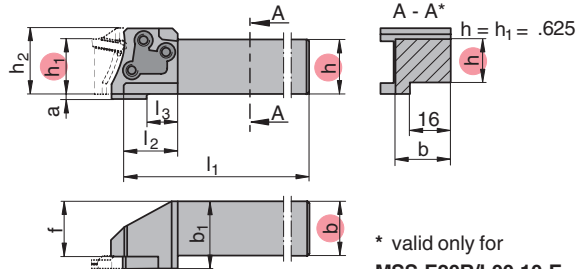

drawing illustrates right hand execution

\* valid only for MSS-E20R/L00-10-E

Bgr.	h=h <sub>1</sub>	b	type, ordering description	[inch]								modules
				f	b <sub>1</sub>	h <sub>2</sub>	l <sub>1</sub>	l <sub>2</sub>	l <sub>3</sub>	a		
E12	.500	.500	MSS-E12R00-08-E	.512	.650	.598	3.00	.47	—	—	—	MSS-E12R...
E16	.625	.625	MSS-E16R00-10-E	.650	.787	.763	3.50	.63	—	—	—	MSS-E16R...
E20	.625	.750	MSS-E20R00-10-E*	.793	.955	.945	3.50	.79	—	—	—	MSS-E20R...
	.750	.750	MSS-E20R00-12-E	.793	.955	.907	4.50	.79	.394	.077	—	MSS-E20R...
E25	1.000	1.000	MSS-E25R00-16-E	1.020	1.236	1.197	5.50	.98	—	—	—	MSS-E25R...
E32	1.250	1.000	MSS-E32R00-85-E	1.020	1.236	1.486	6.50	1.26	—	—	—	MSS-E32R...
	1.250	1.250	MSS-E32R00-20-E	1.279	1.496	1.527	7.00	1.26	.630	.118	—	MSS-E32R...
E12	.500	.500	MSS-E12L00-08-E	.512	.650	.598	3.00	.47	—	—	—	MSS-E12L...
E16	.625	.625	MSS-E16L00-10-E	.650	.787	.763	3.50	.63	—	—	—	MSS-E16L...
E20	.625	.750	MSS-E20L00-10-E*	.793	.955	.945	3.50	.79	—	—	—	MSS-E20L...
	.750	.750	MSS-E20L00-12-E	.793	.955	.907	4.50	.79	.394	.077	—	MSS-E20L...
E25	1.000	1.000	MSS-E25L00-16-E	1.020	1.236	1.197	5.50	.98	—	—	—	MSS-E25L...
E32	1.250	1.000	MSS-E32L00-85-E	1.020	1.236	1.486	6.50	1.26	—	—	—	MSS-E32L...
	1.250	1.250	MSS-E32L00-20-E	1.279	1.496	1.527	7.00	1.26	.630	.118	—	MSS-E32L...

Bgr. = assembly size

ordering example: 1 piece MSS-E20R00-12-E

spare parts and accessories	clamping screw	key	T-key
MSS-E12R/L00-08-E	78 97 200 (M2,5 x 10 - T08)	77 24 106 (T08)	—
MSS-E16R/L00-10-E	78 97 202 (M3,5 x 12,5 - T15)	—	78 97 208 (T15)
MSS-E20R/L00-10-E	78 97 203 (M4 x 14 - T15)	—	78 97 208 (T15)
MSS-E20R/L00-12-E	78 97 203 (M4 x 14 - T15)	—	78 97 208 (T15)
MSS-E25R/L00-16-E	78 97 205 (M5 x 18 - T20)	—	78 97 207 (T20)
MSS-E32R/L00-85-E	78 97 206 (M6 x 20 - T25)	—	78 83 304 (T25)
MSS-E32R/L00-20-E	78 97 206 (M6 x 20 - T25)	—	78 83 304 (T25)

tools / modules	FX	GX09	GX16	GX09/16	GX24	GX24 axial	LX	TC
see page	D10/11	D12	D13	D14/15	D16	D17-D20	D21	D31

# Tools

## Modular system (MSS)

Tools

Application					Turning				
-------------	--	--	--	--	---------	--	--	--	--

shank 90°

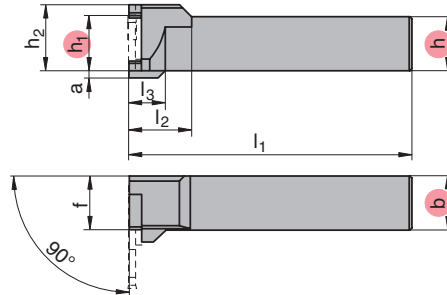

drawing illustrates right hand execution

Bgr.	h=h <sub>1</sub>	b	type, ordering description	[inch]							modules
				f	h <sub>2</sub>	l <sub>1</sub>	l <sub>2</sub>	l <sub>3</sub>	a		
E20	.750	.750	R	MSS-E20R90-12-E	.787	.922	4.50	.787	.287	.077	MSS-E20L...
E25	1.000	1.000		MSS-E25R90-16-E	1.000	1.197	5.50	1.102	—	—	MSS-E25L...
E32	1.250	1.000		MSS-E32R90-85-E	1.260	1.486	6.50	1.338	—	—	MSS-E32L...
	1.250	1.250	MSS-E32R90-20-E	1.260	1.527	8.00	1.338	.756	.118	MSS-E32L...	
E20	.750	.750	L	MSS-E20L90-12-E	.787	.922	4.50	.787	.287	.077	MSS-E20R...
E25	1.000	1.000		MSS-E25L90-16-E	1.000	1.197	5.50	1.102	—	—	MSS-E25R...
E32	1.250	1.000		MSS-E32L90-85-E	1.260	1.486	6.50	1.338	—	—	MSS-E32R...
	1.250	1.250		MSS-E32L90-20-E	1.260	1.527	8.00	1.338	.756	.118	MSS-E32R...

Bgr. = assembly size

ordering example: 1 piece MSS-E20R90-12-E



**Attention in case of 90°**  
right hand shank - left module  
left hand shank - right module

spare parts and accessories	clamping screw	key	T-key
MSS-E20R/L90-12-E	78 97 203 (M4 x 14 - T15)	—	78 97 208 (T15)
MSS-E25R/L90-16-E	78 97 205 (M5 x 18 - T20)	—	78 97 207 (T20)
MSS-E32R/L90-85-E	78 97 206 (M6 x 20 - T25)	—	78 83 304 (T25)
MSS-E32R/L90-20-E	78 97 206 (M6 x 20 - T25)	—	78 83 304 (T25)

Shanks



page D2-D9

External modules



page D10-D21

Boring bars



page D23-D25

Internal modules



page D26-D29

Threading



page D30-D35

UTS



page D36-D40

Block - blade



page D41-D45

tools / modules	FX	GX16	GX16	GX24	GX24 axial	LX	TC
see page							
	D10/11	D13	D14/15	D16	D17-D20	D21	D31

D3

# Tools

## Modular system (MSS)

MSS - 0°



page D2

MSS - 90°



page D3

MSS - 45°



page D4

Adapter



page D5

GX mono



page D6

GMS



page D7

FX mono



page D8 - D9

Application												
-------------	--	--	--	--	--	--	--	--	--	--	--	--

shank 45°



drawing illustrates right hand execution

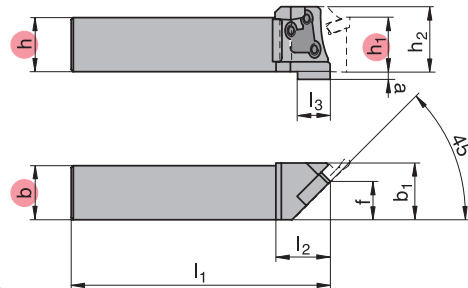

[inch]

Bgr.	h=h <sub>1</sub>	b	type, ordering description	f	b <sub>1</sub>	h <sub>2</sub>	l <sub>1</sub>	l <sub>2</sub>	l <sub>3</sub>	a	modules
E20	.750	.750	R MSS-E20R45-12-E	.571	.846	.907	4.50	.79	.421	.077	MSS-E20L...
E25	1.000	1.000	R MSS-E25R45-16-E	.709	1.024	1.197	5.50	.98	.421	.077	MSS-E25L...
E20	.750	.750	L MSS-E20L45-12-E	.650	1.240	.907	4.50	.79	.421	.077	MSS-E20R...
E25	1.000	1.000	L MSS-E25L45-16-E	.709	1.024	1.197	5.50	.98	.421	.077	MSS-E25R...

Bgr. = assembly size

ordering example: 1 piece MSS-E20R45-12-E



Attention in case of 45°  
right hand shank - left module  
left hand shank - right module





spare parts and accessories	clamping screw	clamping screw short	T-key
MSS-E20R/L45-12-E	78 97 203 (M4 x 14 - T15)	78 97 209 (M4 x 11 - T15)	78 97 208 (T15)
MSS-E25R/L45-16-E	78 97 205 (M5 x 18 - T20)	78 97 210 (M5 x 13,5 - T20)	78 97 207 (T20)

tools / modules	GX16 									
see page	D13									

# Tools

## Modular system (MSS)

Tools

Application					turning				
-------------	---	---	---	---	---------	--	--	--	--

### adapter



Assembly dimensions details are in tech chapter E42 and E43.



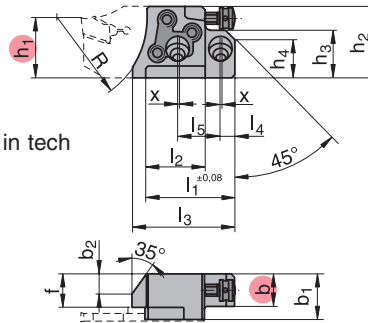

drawing illustrates right hand execution











Bgr.	h <sub>1</sub>	b	type, ordering description	f	b <sub>1</sub>	b <sub>2</sub>	h <sub>2</sub>	h <sub>3</sub>	h <sub>4</sub>	l <sub>1</sub>	modules	
E20	.787	.421	R	MSS-E20R00-AD	.441	.602	.275	.944	.630	.512	1.18	MSS-E20R...
			L	MSS-E20L00-AD								MSS-E20L...
E25	.984	.496	R	MSS-E25R00-AD	.516	.732	.334	1.181	.787	.630	1.46	MSS-E25R...
			L	MSS-E25L00-AD								MSS-E25L...
E32	1.260	.575	R	MSS-E32R00-AD	.594	.811	.452	1.496	1.024	.866	1.81	MSS-E32R...
			L	MSS-E32L00-AD								MSS-E32L...

Bgr.	h <sub>1</sub>	b	type, ordering description	l <sub>2</sub>	l <sub>3</sub>	l <sub>4</sub>	l <sub>5</sub>	R	x [mm]	modules	
E20	.787	.421	R	MSS-E20R00-AD	.79	1.358	.197	.561	1.200	0,5	MSS-E20R...
			L	MSS-E20L00-AD							MSS-E20L...
E25	.984	.496	R	MSS-E25R00-AD	.98	1.673	.256	.709	1.496	1,0	MSS-E25R...
			L	MSS-E25L00-AD							MSS-E25L...
E32	1.260	.575	R	MSS-E32R00-AD	1.26	2.106	.295	.925	1.917	1,0	MSS-E32R...
			L	MSS-E32L00-AD							MSS-E32L...

Bgr. = assembly size

spare parts and accessories	 clamping screw	 clamp bolt	 T-key	 adjustment screw
MSS-E20R/L00-AD	78 97 203 (M4 x 14 - T15)	78 97 211 (M4 x 12 - 12.9DIN912)	78 97 208 (T15)	78 97 215 (M4 x 10)
MSS-E25R/L00-AD	78 97 205 (M5 x 18 - T20)	78 97 212 (M5 x 16 - 12.9DIN912)	78 97 207 (T20)	78 97 217 (M5 x 12)
MSS-E32R/L00-AD	78 97 206 (M6 x 20 - T25)	78 97 213 (M6 x 20 - 12.9DIN912)	78 83 304 (T25)	78 97 216 (M6 x 16)

ordering example: 1 piece MSS-E32R00-AD

tools / modules	FX	GX16	GX16	GX24	GX24 axial	LX	TC
							
see page	D10/11	D13	D14/15	D16	D17-D20	D21	D31

Shanks



page D2 - D9

External modules



page D10-D21

Boring bars



page D23-D25

Internal modules



page D26-D29

Threading



page D30-D35

UTS



page D36-D40

Block - blade



page D41-D45

D5

# Tools

## Monobloc holder GX09 system

MSS - 0°



page D2

MSS - 90°



page D3

MSS - 45°



page D4

Adapter



page D5

GX mono



page D6

GmS



page D7

FX mono



page D8-D9

Application													
-------------	--	--	--	--	--	--	--	--	--	--	--	--	--

### GX monobloc holder



drawing illustrates right hand execution

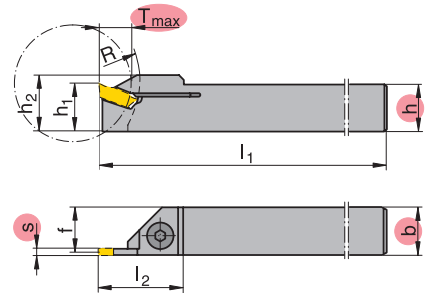

h=h <sub>1</sub>	b	s	T <sub>max</sub>	type, ordering description	f	h <sub>2</sub>	l <sub>1</sub>	l <sub>2</sub>	R	grooving inserts	page
.375	.375	.079-.148	.27	R	.349	.472	6.00	.709	.590	GX09 ...	C8/12/16/17
				L							

ordering example: 1 piece E10R00-06-E

spare parts and accessories	clamping screw	T-key
10R/L00-06-E	78 97 209 (M4 x 11 - T15)	78 97 208 (T15)



**attention:** When using rh or lh insert, the insert support seat requires modification to prevent damage to insert.

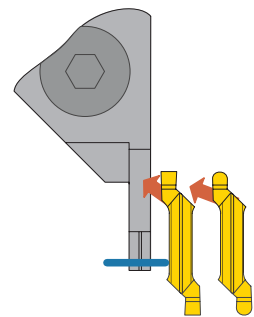

tools / modules											
see page											



# Tools

## Monobloc holder GmS system



Tools

Application									
-------------	---	--	--	--	--	--	--	--	--

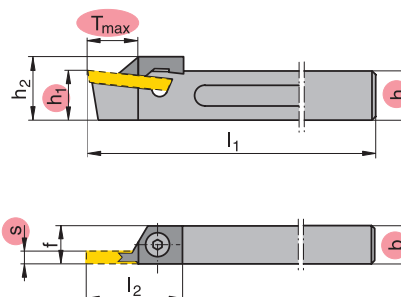

### GMS monobloc holder



drawing illustrates right hand execution

				[inch]						
$h=h_1$	$b$	$s$	$T_{max}$	type, ordering description	$f$	$h_2$	$l_1$	$l_2$	parting inserts	page
.630	.472	.118	.55	R  CLCDR 1612 K30	.472	.827	4.92	1.220	LDMX 30F.	C23
				L  CLCDL 1612 K30						

ordering example: 1 piece CLCDR 1612 K30

spare parts and accessories	clamp 	clamping screw 
CLCDR 1616K30	78 02 211	78 02 212
CLCDL 1616K30	78 02 210	

#### Shanks



page D2-D9

#### External modules



page D10-D21

#### Boring bars



page D23-D25

#### Internal modules



page D26-D29

#### Threading



page D30-D35

#### UTS



page D36-D40

#### Block - blade



page D41-D45

tools / modules									
see page									

# Tools

## Monobloc holder FX system

MSS - 0°



page D2

MSS - 90°



page D3

MSS - 45°



page D4

Adapter



page D5

GX mono



page D6

GMS



page D7

FX mono

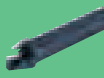

page D8-D9

Application									
-------------	--	--	--	--	--	--	--	--	--

### right FX monobloc holder

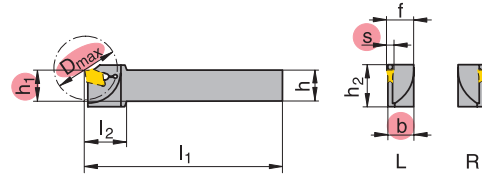

drawing illustrates right hand execution

h=h <sub>1</sub>	b	s	D <sub>max</sub>	type, ordering description	[inch]				parting inserts	page
					f	h <sub>2</sub>	l <sub>1</sub>	l <sub>2</sub>		
.375	.375	.087	1.18	XLCER 06 M22 FX-E	.386	.768	6.00	.75	FX 2.2...	C2
.500	.500	.087	1.18	XLCER 08 F22 FX-E	.511	.768	3.00	.75	FX 2.2...	C2
.500	.500	.087	1.18	XLCER 08 M22 FX-E	.511	.768	6.00	.75	FX 2.2...	C2
.562	.563	.087	1.18	XLCER 09 M22 FX-E	.573	.768	6.00	.75	FX 2.2...	C2
.625	.625	.087	1.18	XLCER 10 H22 FX-E	.636	.768	4.00	.75	FX 2.2...	C2
.625	.625	.122	1.38	XLCFR 10 H31 FX-E	.639	.886	4.00	.88	FX 3.1...	C3
.750	.750	.122	1.57	XLCFR 12 K31 FX-E	.764	1.024	5.00	1.03	FX 3.1...	C3
1.000	.750	.122	1.97	XLCFR 64 M31 FX-E	.764	1.256	6.00	1.27	FX 3.1...	C3
.750	.750	.161	1.97	XLCFR 12 K41 FX-E	.768	1.024	5.00	1.03	FX 4.1...	C4
1.000	.750	.161	1.97	XLCFR 64 M41 FX-E	.768	1.256	6.00	1.27	FX 4.1...	C4

ordering example: 1 piece XLCFR 64 M31 FX-E

spare parts and accessories	ejector
XLCER 06 M22 FX-E	78 02 180
XLCER 08 F22 FX-E	
XLCER 08 M22 FX-E	
XLCER 09 M22 FX-E	
XLCER 10 H22 FX-E	
XLCFR 10 H31 FX-E	78 02 181
XLCFR 12 K31 FX-E	
XLCFR 64 M31 FX-E	
XLCFR 12 K41 FX-E	
XLCFR 64 M41 FX-E	

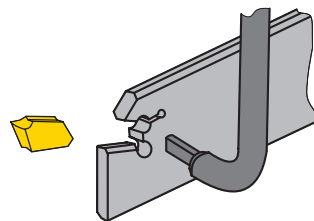

ejector for change of inserts

tools / modules									
see page									

# Tools

## Monobloc holder FX system

Tools

Application									
-------------	---	--	--	--	--	--	--	--	--

### left FX monobloc holder

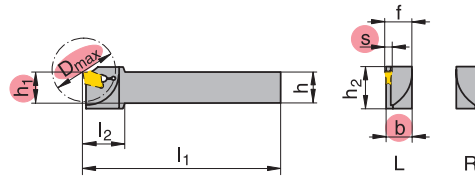

drawing illustrates left hand execution

h=h <sub>1</sub>	b	s	D <sub>max</sub>	[inch]							
				type, ordering description	f	h <sub>2</sub>	l <sub>1</sub>	l <sub>2</sub>	parting inserts	page	
.375	.375	.087	1.18	L	XLCEL 06 M22 FX-E	.386	.768	6.00	.75	FX 2.2...	C2
.500	.500	.087	1.18		XLCEL 08 F22 FX-E	.512	.768	3.00	.75	FX 2.2...	C2
.500	.500	.087	1.18		XLCEL 08 M22 FX-E	.512	.768	6.00	.75	FX 2.2...	C2
.562	.563	.087	1.18		XLCEL 09 M22 FX-E	.573	.768	6.00	.75	FX 2.2...	C2
.625	.625	.087	1.18		XLCEL 10 H22 FX-E	.636	.768	4.00	.75	FX 2.2...	C2
.625	.625	.122	1.38		XLCFL 10 H31 FX-E	.639	.886	4.00	.88	FX 3.1...	C3
.750	.750	.122	1.57		XLCFL 12 K31 FX-E	.764	1.024	5.00	1.03	FX 3.1...	C3
1.000	.750	.122	1.97		XLCFL 64 M31 FX-E	.764	1.256	6.00	1.27	FX 3.1...	C3
.750	.750	.161	1.97		XLCFL 12 K41 FX-E	.768	1.024	5.00	1.03	FX 4.1...	C4
1.000	.750	.161	1.97		XLCFL 64 M41 FX-E	.768	1.256	6.00	1.27	FX 4.1...	C4

ordering example: 1 piece XLCFL 10 H31 FX-E

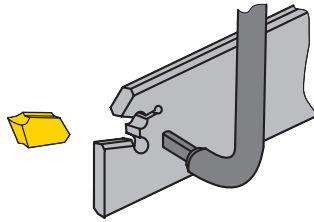
spare parts and accessories	ejector	 <p>ejector for change of inserts</p>
XLCEL 06 M22 FX-E	78 02 180	
XLCEL 08 F22 FX-E		
XLCEL 08 M22 FX-E		
XLCEL 09 M22 FX-E		
XLCEL 10 H22 FX-E		
XLCFL 10 H31 FX-E	78 02 181	
XLCFL 12 K31 FX-E		
XLCFL 64 M31 FX-E		
XLCFL 12 K41 FX-E		
XLCFL 64 M41 FX-E		

tools / modules								
see page								

shanks



page D2-D9

External modules



page D10-D21

Boring bars



page D23-D25

Internal modules



page D26-D29

Threading



page D30-D35

UTS



page D36-D40

Block - blade



page D41-D45

# MSS modules (external)

## Parting off FX system

FX short



page D10

FX long



page D11

GX09



page D12

GX16



page D13

GX09



page D14

GX16



page D15

GX24



page D16

GX axial



page D17-D20

LX



page D21

Application												
-------------	--	--	--	--	--	--	--	--	--	--	--	--

FX short

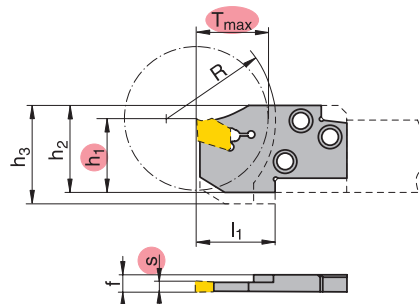

drawing illustrates right hand execution

Bgr.	s	T <sub>max.</sub>	type, ordering description	[inch]							parting inserts	page	
				f	l <sub>1</sub>	h <sub>1</sub>	h <sub>2</sub>	h <sub>3</sub>	R				
E20	.087	.79	R	MSS-E20R20-FX2.2	.184	.86	.787	.945	1.063	1.181	FX 2.2..	C2	
	.122			MSS-E20R20-FX3.1	.187						FX 3.1..	C3	
	.161			MSS-E20R20-FX4.1	.191						FX 4.1..	C4	
	.087		L	MSS-E20L20-FX2.2	.184						FX 2.2..	C2	
	.122			MSS-E20L20-FX3.1	.187						FX 3.1..	C3	
	.161			MSS-E20L20-FX4.1	.191						FX 4.1..	C4	
E25	.087	.98	R	MSS-E25R20-FX2.2	.243	1.06	.984	1.181	—	1.476	FX 2.2..	C2	
	.122			MSS-E25R25-FX3.1	.246						FX 3.1..	C3	
	.161			MSS-E25R25-FX4.1	.250						FX 4.1..	C4	
	.201			MSS-E25R25-FX5.1	.254						FX 5.1..	C4	
	.256			MSS-E25R25-FX6.5	.258						FX 6.5..	C5	
	.087			.79	L						MSS-E25L20-FX2.2	.243	1.06
	.122	MSS-E25L25-FX3.1	.246			FX 3.1..	C3						
	.161	MSS-E25L25-FX4.1	.250			FX 4.1..	C4						
	.201	MSS-E25L25-FX5.1	.254			FX 5.1..	C4						
	.256	MSS-E25L25-FX6.5	.258			FX 6.5..	C5						
	E32	.122	1.26			R	MSS-E32R32-FX3.1	.246	1.34	1.260	1.496	—	
		.161		MSS-E32R32-FX4.1	.250		FX 4.1..	C4					
.201		MSS-E32R32-FX5.1		.254	FX 5.1..		C4						
.256		MSS-E32R32-FX6.5		.258	FX 6.5..		C5						
.122		L		MSS-E32L32-FX3.1	.246		FX 3.1..	C3					
.161				MSS-E32L32-FX4.1	.250	FX 4.1..	C4						
.201				MSS-E32L32-FX5.1	.254	FX 5.1..	C4						
.256				MSS-E32L32-FX6.5	.258	FX 6.5..	C5						

Bgr. = assembly size

ordering example: 1 piece MSS-E32R32 FX5.1

tools	0°	90°	UTS 0°	UTS 90°	adapter			
see page	D2	D3	D36	D37	D5			

# MSS modules (external)

## Parting off FX system

Tools

Application											
-------------	--	--	--	--	--	--	--	--	--	--	--

FX long

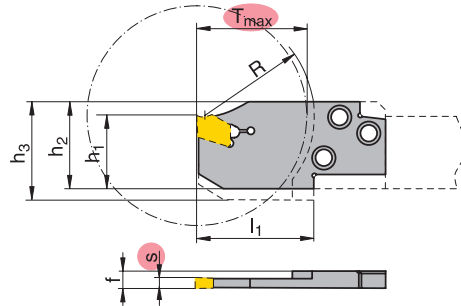

drawing illustrates right hand execution

Bgr.	s	T <sub>max</sub>	type, ordering description	[inch]							parting inserts	page
				f	l <sub>1</sub>	h <sub>1</sub>	h <sub>2</sub>	h <sub>3</sub>	R			
E25	.122	1.38	R	MSS-E25R35-FX3.1	.246	1.46	.984	1.181	—	1.476	FX 3.1..	C 3
	.161			MSS-E25R35-FX4.1	.250						FX 4.1..	C 4
	.201			MSS-E25R35-FX5.1	.254						FX 5.1..	C 4
	.256			MSS-E25R35-FX6.5	.258						FX 6.5..	C 6
	.122		L	MSS-E25L35-FX3.1	.246	1.46	.984	1.181	—	1.476	FX 3.1..	C 3
	.161			MSS-E25L35-FX4.1	.250						FX 4.1..	C 4
	.201			MSS-E25L35-FX5.1	.254						FX 5.1..	C 4
	.256			MSS-E25L35-FX6.5	.258						FX 6.5..	C 6
E32	.122	1.77	R	MSS-E32R45-FX3.1	.246	1.85	1.260	1.496	—	1.890	FX 3.1..	C 3
	.161			MSS-E32R45-FX4.1	.250						FX 4.1..	C 4
	.201			MSS-E32R45-FX5.1	.254						FX 5.1..	C 4
	.256			MSS-E32R45-FX6.5	.258						FX 6.5..	C 6
	.122		L	MSS-E32L45-FX3.1	.246	1.85	1.260	1.496	—	1.890	FX 3.1..	C 3
	.161			MSS-E32L45-FX4.1	.250						FX 4.1..	C 4
	.201			MSS-E32L45-FX5.1	.254						FX 5.1..	C 4
	.256			MSS-E32L45-FX6.5	.258						FX 6.5..	C 6

Bgr. = assembly size

spare parts and accessories	ejector
MSS-E .. -FX 2.2	78 02 180
MSS-E .. -FX 3.1	78 02 181
MSS-E .. -FX 4.1	
MSS-E .. -FX 5.1	
MSS-E .. -FX 6.5	

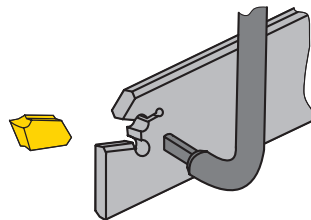

ejector for change of inserts

tools	0°	90°	UTS 0°	UTS 90°	adapter			
see page	D2	D3	D36	D37	D5			

Shanks



page D2-D9

External modules



page D10-D21

Boring bars



page D23-D25

Internal modules



page D26-D29

Threading



page D30-D35

UTS



page D36-D40

Block - blade



page D41-D45

D11



# MSS modules external

## Circlip and O - ring grooves GX09 system

FX - court



page D10

FX - long



page D11

GX09



page D12

GX16



page D13

GX09



page D14

GX16



page D15

GX24



page D16

GX axial





page D17-D20

LX

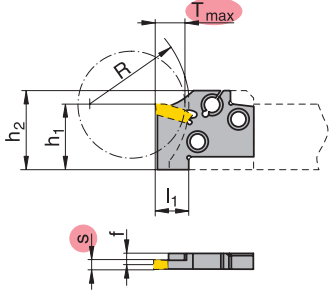

page D21

Application											
											
		<p><b>GX09</b></p> 									
Bgr.	s	T <sub>max</sub>	[inch]							grooving inserts	page
type, ordering description	f	l <sub>1</sub>	h <sub>1</sub>	h <sub>2</sub>	R						
E12	< .077	.08	R	MSS-E12R02-GX09-1	.124	.31	.472	.571	.709	GX09-1...R/L	C16/20
L			MSS-E12L02-GX09-1	GX09-1...R/L							
E16			R	MSS-E16R02-GX09-1			.630	.768	.945	GX09-1...R/L	
L			MSS-E16L02-GX09-1	GX09-1...R/L							

Bgr. = assembly size

ordering example: 1 piece MSS-E12R02-GX09-1

tools	0°										
											
see page	D2										

# MSS modules external

## Circlip and O - ring grooves GX16 system

Application									
-------------	---	---	--	--	--	--	--	--	--

### GX16

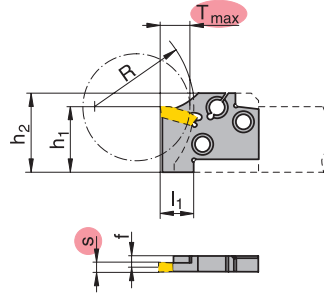





drawing illustrates right hand execution

Bgr.	s	T <sub>max</sub>	[inch]								
			type, ordering description	f	l <sub>1</sub>	h <sub>1</sub>	h <sub>2</sub>	R	grooving inserts	page	
E20	< .108	.118	R	MSS-E20R03-GX16-2	.134		.787	.945	1.181	GX16-2...R/L	C18 C21
			L	MSS-E20L03-GX16-2						GX16-2...R/L	
E25			R	MSS-E25R03-GX16-2	.51	.984	1.181	1.476	GX16-2...R/L		
				L					MSS-E25L03-GX16-2	GX16-2...R/L	
E32			R	MSS-E32R03-GX16-2	.193	1.260	1.496	1.890	GX16-2...R/L		
				L					MSS-E32L03-GX16-2	GX16-2...R/L	

Bgr. = assembly size

ordering example: 1 piece MSS-E32R03-GX16-2

tools	0°	90°	45°	UTS 0°	UTS 90°	UTS 45°	adapter
see page							
	D2	D3	D4	D36	D37	D38	D5

### Tools

#### Shanks



page D2-D9

#### External modules



page D10-D21

#### Boring bars



page D23-D25

#### Internal modules



page D26-D29

#### Threading



page D30-D35

#### UTS



page D36-D40

#### Block - blade



page D41-D45



# MSS modules (external)

## Grooving and turning GX16 system





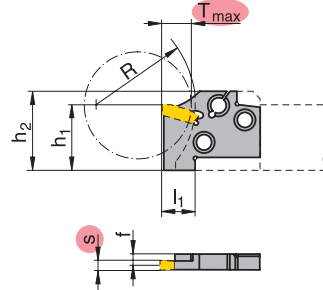

Tools

Application									
-------------	---	---	---	--	--	--	--	--	--

**GX16**







drawing illustrates right hand execution

Bgr.	s	T <sub>max</sub>	type, ordering description	[inch]					grooving inserts	page			
				f	l <sub>1</sub>	h <sub>1</sub>	h <sub>2</sub>	R					
E20	.079 - .108	12	R 	MSS-E20R12-GX16-1	.148	.51	.787	.945	1.181	GX16-1...	C9/10/13 C19/21		
	.109 - .148			MSS-E20R12-GX16-2	.134					GX16-2...			
	.148 - .197			MSS-E20R12-GX16-3	.115					GX16-3...			
	.079 - .108		L 	MSS-E20L12-GX16-1	.148					GX16-1...			
	.109 - .148			MSS-E20L12-GX16-2	.134					GX16-2...			
	.148 - .197			MSS-E20L12-GX16-3	.115					GX16-3...			
E25	.079 - .108		12	R 	MSS-E25R12-GX16-1	.207	.51	.984	1.181	1.476		GX16-1...	C9/10/13 C19/21
	.109 - .148				MSS-E25R12-GX16-2	.193						GX16-2...	
	.148 - .197				MSS-E25R12-GX16-3	.174						GX16-3...	
	.197 - .256				MSS-E25R12-GX16-4	.150						GX16-4...	
	.079 - .108			L 	MSS-E25L12-GX16-1	.207						GX16-1...	
	.109 - .148				MSS-E25L12-GX16-2	.193						GX16-2...	
	.148 - .197	MSS-E25L12-GX16-3			.174	GX16-3...							
	.197 - .256	MSS-E25L12-GX16-4			.150	GX16-4...							
E32	.109 - .148	12	R 	MSS-E32R12-GX16-2	.193	.51	1.260	1.496	1.890	GX16-2...	C9/10/13 C19/21		
	.148 - .197			MSS-E32R12-GX16-3	.174					GX16-3...			
	.197 - .256			MSS-E32R12-GX16-4	.150					GX16-4...			
	.109 - .148			L 	MSS-E32L12-GX16-2					.193		GX16-2...	
	.148 - .197		MSS-E32L12-GX16-3		.174					GX16-3...			
	.197 - .256		MSS-E32L12-GX16-4		.150					GX16-4...			

Bgr. = assembly size

ordering example: 1 piece MSS-E32L12-GX16-4

tools	0°	90°	UTS 0°	UTS 90°	adapter			
								
see page	D2	D3	D36	D37	D5			

Shanks



page D2-D9

External modules



page D10-D21

Boring bars



page D23-D25

Internal modules



page D26-D29

Threading



page D30-D35

UTS



page D36-D40

Block - blade



page D41-D45

D15

# MSS modules (external)

## Grooving and turning GX24 system

FX - short



page D10

FX - long



page D11

GX09



page D12

GX16



page D13

GX09



page D14

GX16



page D15

GX24



page D16

GX axial



page D17-D20

LX



page D21

Application												
<b>GX24</b>												
			drawing illustrates right hand execution									
Bgr.	s	T <sub>max</sub>	[inch]									
			type, ordering description	f	l <sub>1</sub>	h <sub>1</sub>	h <sub>2</sub>	R	grooving inserts	page		
E20	.109 - .148	.827	R	MSS-E20R21-GX24-2	.134	.87	.787	.945	30,0	GX24-2...	C11/14	
	.148 - .197		MSS-E20R21-GX24-3	.115	GX24-3...							
	.109 - .148		MSS-E20L21-GX24-2	.134	GX24-2...							
	.148 - .197		MSS-E20L21-GX24-3	.115	GX24-3...							
E25	.109 - .148		R	MSS-E25R21-GX24-2	.116		.984	1.181	37,5	GX24-2...		
	.148 - .197		MSS-E25R21-GX24-3	.174	GX24-3...							
	.197 - .256		MSS-E25R21-GX24-4*	.150	GX24-4...							
	.315		MSS-E25R21-GX24-5*	.116	GX24-5...							
	.109 - .148		L	MSS-E25L21-GX24-2	.193					GX24-2...		
	.148 - .197		MSS-E25L21-GX24-3	.174	GX24-3...							
	.197 - .256		MSS-E25L21-GX24-4*	.150	GX24-4...							
	.315		MSS-E25L21-GX24-5*	.116	GX24-5...							
E32	.109 - .148	R	MSS-E32R21-GX24-2	.116	1.260	1.496	1.890	GX24-2...				
	.148 - .197	MSS-E32R21-GX24-3	.174	GX24-3...								
	.197 - .256	MSS-E32R21-GX24-4*	.150	GX24-4...								
	.109 - .148	L	MSS-E32L21-GX24-2	.116				GX24-2...				
	.148 - .197	MSS-E32L21-GX24-3	.174	GX24-3...								
	.197 - .256	MSS-E32L21-GX24-4*	.150	GX24-4...								

\*when using the radius insert l<sub>1</sub> = 23mm

Bgr. = assembly size

ordering example: 1 piece MSS-E20R21GX24-2

tools	0°	90°	UTS 0°	UTS 90°	adapter			
see page	D2	D3	D36	D37	D5			



# MSS modules (external)

## Axial grooves GX24 system



Application									
-------------	---	--	--	--	--	--	--	--	--

### GX24 axial



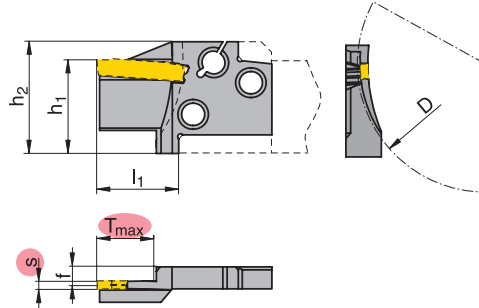

drawing illustrates right hand execution



Bgr.	s	T <sub>max</sub>	D	type, ordering description	[inch]				grooving inserts	page	
					f	l <sub>1</sub>	h <sub>1</sub>	h <sub>2</sub>			
E20	.109 - .148	.551	2.75 - 3.94	R 	MSS-E20R14-GX24-2 A50-70	.134	.87	.787	.945	GX24-2...	C11/14
			2.75 - 3.94		MSS-E20R14-GX24-2 A70-100						
			3.94 - 5.90		MSS-E20R14-GX24-2 A100-150						
			2.75 - 3.94	L 	MSS-E20L14-GX24-2 A50-70						
			2.75 - 3.94		MSS-E20L14-GX24-2 A70-100						
			3.94 - 5.90		MSS-E20L14-GX24-2 A100-150						

ordering example: 1 piece MSS-E20R14-GX24-2 A50-70

tools	0°	90°	adapter					
see page	 D2	 D3	 D5					

### Tools

#### Shanks



page D2-D9

#### External modules



page D10-D21

#### Boring bars



page D23-D25

#### Internal modules



page D26-D29

#### Threading



page D30-D35

#### UTS



page D36-D40

#### Block - blade



page D41-D45

# MSS modules (external)

## Axial grooving GX24 system

FX - short



page D10

FX - long



page D11

GX09



page D12

GX16



page D13

GX09



page D14

GX16



page D15

GX24



page D16

GX axial



page D17-D20





LX

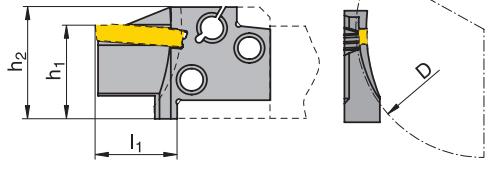
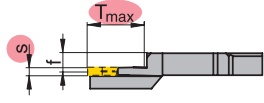

page D21

Application											
<b>GX24 axial</b>											
											
				drawing illustrates right hand execution							
Bgr.	s	T <sub>max</sub>	D	type, ordering description				[inch]			
				f	l <sub>1</sub>	h <sub>1</sub>	h <sub>2</sub>	grooving inserts	page		
E25	.109 - .148	.59	1.97 - 2.75	R	.193	.866	.984	.1.181	MSS-E25R15-GX24-2 A50-70	GX24-2...	C11/14
			2.75 - 3.94						MSS-E25R15-GX24-2 A70-100	GX24-2...	
			3.94 - 5.90						MSS-E25R15-GX24-2 A100-150	GX24-2...	
	.148 - .197		1.97 - 2.75		.174				MSS-E25R15-GX24-3 A50-70	GX24-3...	
			2.75 - 3.94						MSS-E25R15-GX24-3 A70-100	GX24-3...	
			3.94 - 5.90						MSS-E25R15-GX24-3 A100-150	GX24-3...	
	.197 - .256		5.90 - 11.81		.150				MSS-E25R15-GX24-3 A150-300	GX24-3...	
			1.97 - 2.75						MSS-E25R15-GX24-4 A50-70	GX24-4...	
			2.75 - 3.94						MSS-E25R15-GX24-4 A70-100	GX24-4...	
			3.94 - 5.90						MSS-E25R15-GX24-4 A100-150	GX24-4...	
	.109 - .148		5.90 - 11.81		.150				MSS-E25R15-GX24-4 A150-300	GX24-4...	
			1.97 - 2.75						.174	MSS-E25L15-GX24-2 A50-70	
			2.75 - 3.94	MSS-E25L15-GX24-2 A70-100		GX24-2...					
			3.94 - 5.90	MSS-E25L15-GX24-2 A100-150		GX24-2...					
	.148 - .197		1.97 - 2.75	.150	MSS-E25L15-GX24-3 A50-70	GX24-3...					
			2.75 - 3.94		MSS-E25L15-GX24-3 A70-100	GX24-3...					
			3.94 - 5.90		MSS-E25L15-GX24-3 A100-150	GX24-3...					
			5.90 - 11.81		MSS-E25L15-GX24-3 A150-300	GX24-3...					
	.197 - .256		1.97 - 2.75	.150	MSS-E25L15-GX24-4 A50-70	GX24-4...					
			2.75 - 3.94		MSS-E25L15-GX24-4 A70-100	GX24-4...					
3.94 - 5.90		MSS-E25L15-GX24-4 A100-150	GX24-4...								
5.90 - 11.81		MSS-E25L15-GX24-4 A150-300	GX24-4...								

ordering example: 1 piece MSS-E25L15-GX24-4 A150-300

tools	0°	90°	UTS 0°	UTS 90°	adapter			
see page								
	D2	D3	D36	D37	D5			

# MSS modules (external)

## Axial grooving GX24 system

Tools

Application									
-------------	---	--	--	--	--	--	--	--	--

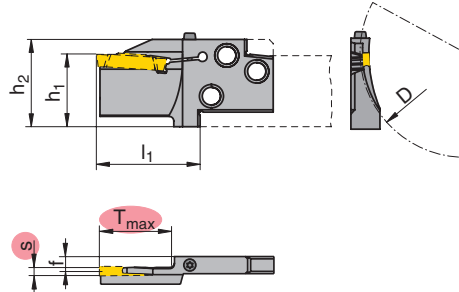

### GX24 axial long



drawing illustrates right hand execution





Bgr.	s	T <sub>max</sub>	D	type, ordering description	[inch]				grooving inserts	page
					f	l <sub>1</sub>	h <sub>1</sub>	h <sub>2</sub>		
E25	.148 - .197	.83	1.97 - 2.75	MSS-E25R21-GX24-3 AS50-70	.180				GX24-3...	C11/14
			2.75 - 3.94	MSS-E25R21-GX24-3 AS70-100					GX24-3...	
			3.94 - 5.90	MSS-E25R21-GX24-3 AS100-150					GX24-3...	
			5.90 - 11.81	MSS-E25R21-GX24-3 AS150-300					GX24-3...	
	.197 - .256	.98	1.97 - 2.75	MSS-E25R25-GX24-4 AS50-70	.155	1.38	.984	1.181	GX24-4...	
			2.75 - 3.94	MSS-E25R25-GX24-4 AS70-100					GX24-4...	
			3.94 - 5.90	MSS-E25R25-GX24-4 AS100-150					GX24-4...	
			5.90 - 11.81	MSS-E25R25-GX24-4 AS150-300					GX24-4...	
	.148 - .197	.83	1.97 - 2.75	MSS-E25L21-GX24-3 AS50-70	.180				GX24-3...	
			2.75 - 3.94	MSS-E25L21-GX24-3 AS70-100					GX24-3...	
			3.94 - 5.90	MSS-E25L21-GX24-3 AS100-150					GX24-3...	
			5.90 - 11.81	MSS-E25L21-GX24-3 AS150-300					GX24-3...	
	.197 - .256	.98	1.97 - 2.75	MSS-E25L25-GX24-4 AS50-70	.155				GX24-4...	
			2.75 - 3.94	MSS-E25L25-GX24-4 AS70-100					GX24-4...	
			3.94 - 5.90	MSS-E25L25-GX24-4 AS100-150					GX24-4...	
			5.90 - 11.81	MSS-E25L25-GX24-4 AS150-300					GX24-4...	

ordering example: 1 piece MSS-E25L25-GX24-4 AS150-300

spare parts and accessories			
	clamping screw	T-key	Nm (inlbs)
MSS-E25R/L25...	78 97 221 (M3,5 x 14 - T15)	78 97 208 (T15)	≤ 3,3 (29)



Axial modules as long execution can be clamped on both sides!

tools	0°	90°	UTS 0°	UTS 90°	adapter			
								
see page	D2	D3	D36	D37	D5			

Shanks



page D2-D9

External  
modules



page D10-D21

Boring bars



page D23-D25

Internal  
modules



page D26-D29

Threading



page D30-D35

UTS



page D36-D40

Block - blade



page D41-D45

D19

# MSS modules (external)

## Axial grooves GX24 system

FX - short



page D10

FX - long



page D11

GX09



page D12

GX16



page D13

GX09



page D14

GX16



page D15

GX24



page D16

GX axial



page D17-D20

LX



page D21

D20

Application									
-------------	--	--	--	--	--	--	--	--	--

### GX24 axial

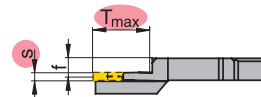
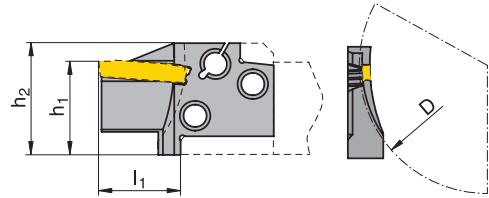

drawing illustrates right hand execution

Bgr.	s	T <sub>max</sub>	D	type, ordering description	[inch]				grooving inserts	page	
					f	l <sub>1</sub>	h <sub>1</sub>	h <sub>2</sub>			
E32	.148 - .197	.59	2.75 - 3.94	R	.174	.87	1.26	1.496	GX24-3...	C11/14	
			3.94 - 5.90								
			5.9 - 11.81								
	.197 - .256		2.75 - 3.94		L				.150		GX24-4...
			3.94 - 5.90								
			5.9 - 11.81								
	.148 - .197		2.75 - 3.94	L	.174				GX24-3...		
			3.94 - 5.90								
			5.9 - 11.81								
	.197 - .256		2.75 - 3.94		L				.150		GX24-4...
			3.94 - 5.90								
			5.9 - 11.81								
			11.81 - 35.43								
				MSS-E32L15-GX24-4 A300-900							

ordering example: 1 piece MSS-E32L15-GX24-4 A150-300

tools	0°	90°	UTS 0°	UTS 90°	adapter			
see page	D2	D3	D36	D37	D5			

# MSS modules (external)

## Grooving and turning LX system

Tools

Application									
-------------	--	--	--	--	--	--	--	--	--

### LX system

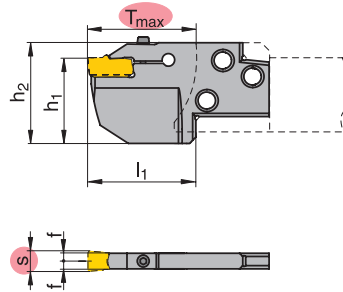

Bgr.	S	T <sub>max</sub>	[inch]							
			type, ordering description	f	l <sub>1</sub>	h <sub>1</sub>	h <sub>2</sub>	grooving inserts	page	
32	.315	.98	N	MSS-E32N25-LX	.134	1.06	1.260	1.732	LX .....	C7
32	.315	1.26	N	MSS-E32N32-LX	.134	1.34	1.260	1.732	LX .....	C7
32	.315	1.77	N	MSS-E32N45-LX	.134	1.85	1.260	1.732	LX .....	C7

Bgr. = assembly size

ordering example: 1 piece MSS-E32N32-LX

spare parts and accessories	clamping screw	T-key	Nm (inlbs)
MSS-E32N25-LX	78 97 218 (M4 x 18 - T20)	78 97 207 (T20)	≤ 4,0 (35,4)
MSS-E32N32-LX			
MSS-E32N45-LX			

radial grooving	axial grooving	internal grooving
	<p>T<sub>max</sub>:</p> <p>.75 - MSS-E32N25-LX</p> <p>1.02 - MSS-E32N32-LX</p> <p>1.54 - MSS-E32N45-LX</p>	<p>T<sub>max</sub>:</p> <p>.55 - MSS-E32N25-LX</p> <p>.83 - MSS-E32N32-LX</p> <p>1.34 - MSS-E32N45-LX</p>
	D <sub>min</sub> > 19.68 inch	D <sub>min</sub> > 7.87 inch

See also page E25!

tools	0°	90°	UTS 0°	UTS 90°	adapter			
see page	D2	D3	D36	D37	D5			

Shanks



page D2-D9

External modules



page D10-D21

Boring bars



page D23-D25

Internal modules



page D26-D29

Threading



page D30-D35

UTS



page D36-D40

Block - blade



page D41-D45

D21



**Execution**

**GX mono**



page D23

**1,5 x D**



page D24

**2,5 x D**





page D25



# Tools

## Monobloc boring bar MSS system

Tools



Application									
-------------	---	---	--	--	--	--	--	--	--

### GX monobloc boring bar

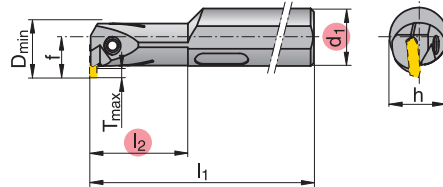

drawing illustrates right hand execution



Bgr.	l <sub>2</sub>	d <sub>1</sub>	type, ordering description	[inch]					grooving inserts	page	
				f	h	l <sub>1</sub>	T <sub>max</sub>	D <sub>min</sub>			
I12	1.18	.625	R 	I12R90-2.5D-GX09-E	.433	.600	6.00	.12	.63	GX09...	C8/12/16 C17/20
I12	1.18	.625	L 	I12L90-2.5D-GX09-E	.433	.600	6.00	.12	.63	GX09...	

Bgr. = assembly size

ordering example: 1 piece I12R90-2,5D-GX09-E

spare parts and accessories	clamping screw 	key 	T-key 
I12R90-2.5D-GX09-E	78 97 202 (M3,5 x 12,5 - T15)	—	78 97 208 (T15)
I12L90-2.5D-GX09-E			



**attention:** When using rh or lh insert, the insert support seat requires modification to prevent damage to insert.

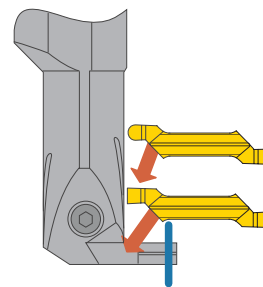

--	--	--	--	--	--	--	--	--	--

Shanks



page D2-D9

External modules



page D10-D21

Boring bars

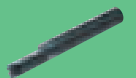

page D23-D25

Internal modules



page D26-D29

Threading



page D30-D35

UTS



page D36-D40

Block - blade



page D41-D45

# Tools

## Boring bar MSS system

GX mono



page D23

1.5 x D



page D24

2.5 x D

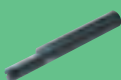

page D25

Application									
-------------	--	--	--	--	--	--	--	--	--

### boring bar 1.5D

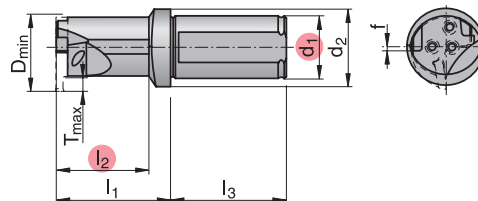

drawing illustrates right hand execution

[inch]											
Bgr.	$l_2$	$d_1$		type, ordering description	$d_2$	f	$l_1$	$l_3$	$T_{max}$	$D_{min}$	modules
I16	.94	.750	R	MSS-I16R90-1.5D-E	.984	.039	1.26	2.000	.16	.79	MSS-I16R...
I20	1.18	.750		MSS-I20R90-1.5D-E	.984	.039	1.46	2.000	.20	.98	MSS-I20R...
I25	1.50	1.000		MSS-I25R90-1.5D-E	1.260	.059	1.81	2.250	.24	1.26	MSS-I25R...
I32	1.89	1.250		MSS-I32R90-1.5D-E	1.575	.079	2.32	2.500	.35	1.57	MSS-I32R...
I40	2.36	1.500		MSS-I40R90-1.5D-E	1.986	.098	2.83	3.000	.39	1.97	MSS-I40R... GX16...
									.75	2.36	MSS-I40N... GX24...
I16	.98	.750	L	MSS-I16L90-1.5D-E	.984	.039	1.26	2.000	.16	.79	MSS-I16L...
I20	1.18	.750		MSS-I20L90-1.5D-E	.984	.039	1.46	2.000	.20	.98	MSS-I20L...
I25	1.50	1.000		MSS-I25L90-1.5D-E	1.260	.059	1.81	2.250	.24	1.26	MSS-I25L...
I32	1.89	1.250		MSS-I32L90-1.5D-E	1.575	.079	2.32	2.500	.35	1.57	MSS-I32L...
I40	2.36	1.500		MSS-I40L90-1.5D-E	1.986	.098	2.83	3.000	.39	1.97	MSS-I40L... GX16...
									.75	2.36	MSS-I40N... GX24...

Bgr. = assembly size

ordering example: 1 piece MSS-I20L90-1.5D-E



spare parts and accessories	clamping screw	key	T-key
MSS-I16R/L90-1.5D-E	78 97 200 (M2,5 x 10 - T08)	77 24 106 (T08)	—
MSS-I20R/L90-1.5D-E	78 97 201 (M3 x 11 - T10)	78 82 306 (T10)	—
MSS-I25R/L90-1.5D-E	78 97 202 (M3,5 x 12,5 - T15)	—	78 97 208 (T15)
MSS-I32R/L90-1.5D-E	78 97 204 (M4,5 x 17 - T20)	—	78 97 207 (T20)
MSS-I40R/L90-1.5D-E	78 97 205 (M5 x 18 - T20)	—	78 97 207 (T20)

tools / modules	GX09	GX16	GX24	TC				
see page	D26/28	D27/29	D29	D33				

# Tools

## Boring bar MSS system



Tools

Application			Turning	Milling					
-------------	---	---	---------	---------	--	--	--	--	--

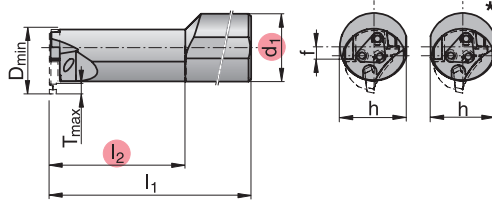
### boring bar 2.5D



drawing illustrates right hand execution



[inch]										
Bgr.	$l_2$	$d_1$	type, ordering description	f	h	$l_1$	$T_{max}$	$D_{min}$	modules	
I16	1.57	.750	R 	MSS-I16R90-2.5D-E	.177	.728	7.00	.16	.79	MSS-I16R...
I20	1.97	1.000		MSS-I20R90-2.5D-E	.236	.953	8.00	.20	.98	MSS-I20R...
I25	2.48	1.250		MSS-I25R90-2.5D-E	.275	1.216	10.00	.24	1.26	MSS-I25R...
I32	3.15	1.500		MSS-I32R90-2.5D-E *)	.374	1.425	12.00	.35	1.57	MSS-I32R...
I40	3.94	2.000		MSS-I40R90-2.5D-E	.433	1.941	14.00	.39	1.97	MSS-I40R... GX16...
							.75	2.36		MSS-I40N... GX24...
I16	1.57	.750	L 	MSS-I16L90-2.5D-E	.177	.728	7.00	.16	.79	MSS-I16L...
I20	1.97	1.000		MSS-I20L90-2.5D-E	.236	.953	8.00	.20	.98	MSS-I20L...
I25	2.48	1.250		MSS-I25L90-2.5D-E	.275	1.216	10.00	.24	1.26	MSS-I25L...
I32	3.15	1.500		MSS-I32L90-2.5D-E *)	.374	1.425	12.00	.35	1.57	MSS-I32L...
I40	3.94	2.000		MSS-I40L90-2.5D-E	.453	1.941	14.00	.39	1.97	MSS-I40L... GX16...
							.75	2.36		MSS-I40N... GX24...





Bgr. = assembly size

ordering example: 1 piece MSS-I20L90-2.5D-E



\*) 2 clamping faces valid only for MSS-I32R/L90-2.5D-E

spare parts and accessories	 clamping screw	 key	 T-key
MSS-I16R/L90-2.5D-E	78 97 200 (M2,5 x 10 - T08)	77 24 106 (T08)	—
MSS-I20R/L90-2.5D-E	78 97 201 (M3 x 11 - T10)	78 83 306 (T10)	—
MSS-I25R/L90-2.5D-E	78 97 202 (M3,5 x 12,5 - T15)	—	78 97 208 (T15)
MSS-I32R/L90-2.5D-E	78 97 204 (M4,5 x 17 - T20)	—	78 97 207 (T20)
MSS-I40R/L90-2.5D-E	78 97 205 (M5 x 18 - T20)	—	78 97 207 (T20)

tools / modules	GX09	GX16	GX24	TC				
								
see page	D26/28	D27/29	D29	D33				

Shanks



page D2-D9

External modules



page D10-D21

Boring bars

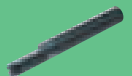

page D23-D25

Internal modules



page D26-D29

Threading



page D30-D35

UTS



page D36-D40

Block - blade



page D41-D45

D25

# MSS modules (internal)

## Circlip and O - ring grooves GX09 system

GX09



page D26

GX16



page D27

GX09



page D28

GX16 / 24



page D29

Application										
GX09										
GX09			drawing illustrates right hand execution							
			[inch]							
Bgr.	s	T <sub>max</sub>	type, ordering description	f	s <sub>1</sub>	h <sub>2</sub>	D <sub>min</sub>	grooving inserts	page	
I16	.077	.08	R	MSS-I16R02-GX09-1	.394	.150	.646	.79	GX09-1...R/L	C16 C20
			L	MSS-I16L02-GX09-1					GX09-1...R/L	
I20			R	MSS-I20R02-GX09-1	.472		.800	.98	GX09-1...R/L	
			L	MSS-I20L02-GX09-1					GX09-1...R/L	
I25			R	MSS-I25R02-GX09-1	.610		.980	1.26	GX09-1...R/L	
			L	MSS-I25L02-GX09-1					GX09-1...R/L	

Bgr. = assembly size

ordering example: 1 piece MSS-I16R02-GX09-1

tools / modules	1,5D	2,5D	UTS					
see page	D24	D25	D39					



# MSS modules (internal)

## Circlip and O - ring grooves GX16 system





Application									
-------------	---	--	--	--	--	--	--	--	--

### GX16

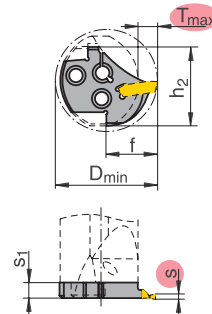



drawing illustrates right hand execution



Bgr.	s	T <sub>max</sub>	[inch]							
			type, ordering description	f	s <sub>1</sub>	h <sub>2</sub>	D <sub>min</sub>	grooving inserts	page	
I32	< .108	.12	R 	MSS-I32R03-GX16-2	.787	.232	1.268	1.57	GX16-2...R/L	C18 C21
			L 	MSS-I32L03-GX16-2					GX16-2...R/L	
I40			R 	MSS-I40R03-GX16-2	.964	.232	1.560	1.97	GX16-2...R/L	
			L 	MSS-I40L03-GX16-2					GX16-2...R/L	

Bgr. = assembly size

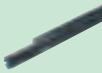
ordering example: 1 piece MSS-I40R03-GX16-2

tools / modules								
see page	D24	D25	D39					

## Tools

### Shanks



page D2-D9

### External modules



page D10-D21

### Boring bars

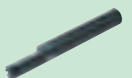

page D23-D25

### Internal modules



page D26-D29

### Threading



page D30-D35

### UTS



page D36-D40

### Block - blade

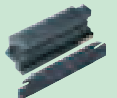

page D41-D45

# MSS modules (internal)

## Grooving and turning GX09 system

GX09



page D26

GX16



page D27

GX09



page D28

GX16 / 24



page D29

Application											
<b>GX09</b>									drawing illustrates right hand execution		
Bgr.	s	T <sub>max</sub>	type, ordering description		f	s <sub>1</sub>	h <sub>2</sub>	D <sub>min</sub>	grooving inserts	page	
I16	.079 - .108	.16	R	MSS-I16R04-GX09-1	.394	.150	.646	.79	GX09-1...	C8/12 C17/20	
	.108 - .148			MSS-I16R04-GX09-2					GX09-2...		
	.079 - .108		L	MSS-I16L04-GX09-1					GX09-1...		
	.108 - .148			MSS-I16L04-GX09-2					GX09-2...		
I20	.079 - .108	.20	R	MSS-I20R05-GX09-1	.472	.150	.800	.98	GX09-1...		
	.108 - .148			MSS-I20R05-GX09-2					GX09-2...		
	.079 - .108		L	MSS-I20L05-GX09-1					GX09-1...		
	.108 - .148			MSS-I20L05-GX09-2					GX09-2...		
I25	.079 - .108	.24	R	MSS-I25R06-GX09-1	.610	.150	.980	1.26	GX09-1...		
	.108 - .148			MSS-I25R06-GX09-2					GX09-2...		
	.079 - .108		L	MSS-I25L06-GX09-1					GX09-1...		
	.108 - .148			MSS-I25L06-GX09-2					GX09-2...		

Bgr. = assembly size

ordering example: 1 piece MSS-I20L05-GX09-2

tools / modules	1,5D	2,5D	UTS					
see page	D24	D25	D39					

# MSS modules (internal)

## Grooving and turning GX16/24 system

Tools





Application									
-------------	---	---	--	--	--	--	--	--	--

### GX16 / 24

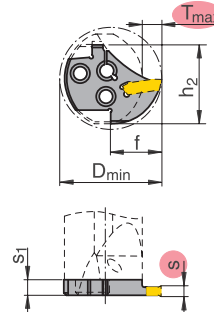



drawing illustrates right hand execution



Bgr.	s	T <sub>max</sub>	type, ordering description	[inch]				grooving inserts	page	
				f	s <sub>1</sub>	h <sub>2</sub>	D <sub>min</sub>			
I32	.079 - .108	.35	R 	MSS-I32R09-GX16-1	.787	.232	1.268	1.57	GX16-1...	C9/10/11 C13/14 C19/21
	.108 - .148			MSS-I32R09-GX16-2					GX16-2...	
	.148 - .197			MSS-I32R09-GX16-3					GX16-3...	
	.197 - .256			MSS-I32R09-GX16-4					GX16-4...	
	.079 - .108		L 	MSS-I32L09-GX16-1					GX16-1...	
	.108 - .148			MSS-I32L09-GX16-2					GX16-2...	
	.148 - .197			MSS-I32L09-GX16-3					GX16-3...	
	.197 - .256			MSS-I32L09-GX16-4					GX16-4...	
I40	.079 - .108	.39	R 	MSS-I40R10-GX16-1	.964	.232	1.560	1.97	GX16-1...	
	.108 - .148	.39		MSS-I40R10-GX16-2	.964	.232	1.560	1.97	GX16-2...	
	.108 - .148	.75		MSS-I40N19-GX24-2	1.319	.244	1.602	2.36	GX24-2...	
	.148 - .197	.39		MSS-I40R10-GX16-3	.964	.232	1.560	1.97	GX16-3...	
	.148 - .197	.75		MSS-I40N19-GX24-3	1.319	.244	1.602	2.36	GX24-3...	
	.197 - .256	.39		MSS-I40R10-GX16-4	.964	.232	1.560	1.97	GX16-4...	
	.197 - .256	.75		MSS-I40N19-GX24-4	1.319	.244	1.602	2.36	GX24-4...	
	.079 - .108	.39		L 	MSS-I40L10-GX16-1	.964	.232	1.560	1.97	
	.108 - .148	.39	MSS-I40L10-GX16-2		.964	.232	1.560	1.97	GX16-2...	
	.108 - .148	.75	MSS-I40N19-GX24-2		1.319	.244	1.602	2.36	GX24-2...	
	.148 - .197	.39	MSS-I40L10-GX16-3		.964	.232	1.560	1.97	GX16-3...	
	.148 - .197	.75	MSS-I40N19-GX24-3		1.319	.244	1.602	2.36	GX24-3...	
	.197 - .256	.39	MSS-I40L10-GX16-4		.964	.232	1.560	1.97	GX16-4...	
	.197 - .256	.75	MSS-I40N19-GX24-4		1.319	.244	1.602	2.36	GX24-4...	

Bgr. = assembly size

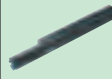
ordering example: 1 piece MSS-I40L10-GX16-4

tools / modules	1,5D	2,5D	UTS					
see page	 D24	 D25	 D39					

Shanks



page D2-D9

External modules



page D10-D21

Boring bars



page D23-D25

Internal modules



page D26-D29

Threading



page D30-D35

UTS



page D36-D40

Block - blade



page D41-D45

D29

# Tools

## Monobloc boring bar TC system - threading

TC mono

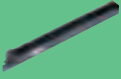

page D30

TC16



page D31

TC mono



page D32

TC16



page D33

TC milling cutter



page D35

Application	Turning								
-------------	---------	--	--	--	--	--	--	--	--

### TC monobloc holder

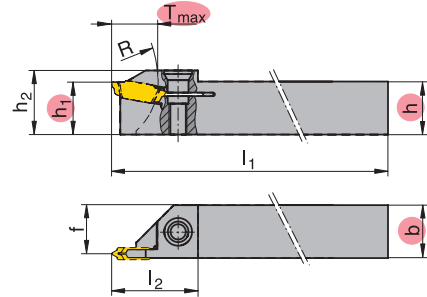

drawing illustrates right hand execution

pitch					[inch]								page
h=h <sub>1</sub>	b	mm	T.P.I.	T <sub>max</sub>	type, ordering description	f	h <sub>2</sub>	l <sub>1</sub>	l <sub>2</sub>	R	threading inserts		
.500	.500	0.5 - 3.0	48 - 8	.39	R	E12R00-08-TC16-E	.461	.598	6.00	.77	.590	TC16-1/2 ...	C24-C26
.500	.500	0.5 - 3.0	48 - 8	.39	L	E12L00-08-TC16-E	.461	.598	6.00	.77	.590	TC16-1/2 ...	

ordering example: 1 piece E12R00-1212-TC16

spare parts and accessories	clamping screw	T-key
E12R00-08-TC16-E	78 97 209 (M4x11-T15)	78 97 208 (T15)
E12L00-08-TC16-E		

tools / modules									
see page									

# MSS modules (external)

## Thread turning TC system



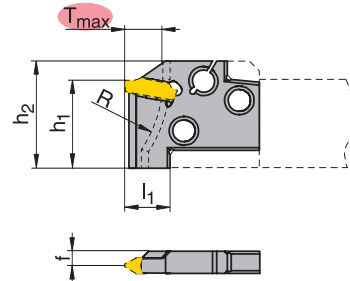

Tools

Application									
-------------	---	--	--	--	--	--	--	--	--

### TC16



drawing illustrates right hand execution

Bgr.	pitch		T <sub>max</sub>	type, ordering description	[inch]					threading inserts	page	
	mm	TP.I.			f	h <sub>1</sub>	l <sub>1</sub>	h <sub>2</sub>	R			
E20	0.5 - 1.5	48 - 16	.31	R 	MSS-E20R-TC16-1	.136	.512	.79	.945	1.181	TC16-1...	C24-C26 C28
	1.75 - 3.0	14 - 8	.47		MSS-E20N-TC16-2	.087	.512	.79	.945	—	TC16-2...	
	0.5 - 1.5	48 - 16	.31	L 	MSS-E20L-TC16-1	.136	.512	.79	.945	1.181	TC16-1...	
	1.75 - 3.0	14 - 8	.47		MSS-E20N-TC16-2	.087	.512	.79	.945	—	TC16-2...	
E25	0.5 - 1.5	48 - 16	.31	R 	MSS-E25R-TC16-1	.205	.512	.98	1.181	1.476	TC16-1...	
	1.75 - 3.0	14 - 8	.39		MSS-E25R-TC16-2	.161	.512	.98	1.181	1.476	TC16-2...	
	3.5 - 5.0	7 - 5	.47		MSS-E25N-TC16-3	.122	.512	.98	1.181	—	TC16-3...	
	0.5 - 1.5	48 - 16	.31	L 	MSS-E25L-TC16-1	.205	.512	.98	1.181	1.476	TC16-1...	
	1.75 - 3.0	14 - 8	.39		MSS-E25L-TC16-2	.161	.512	.98	1.181	1.476	TC16-2...	
	3.5 - 5.0	7 - 5	.47		MSS-E25N-TC16-3	.122	.512	.98	1.181	—	TC16-3...	

Bgr. = assembly size

ordering example: 1 piece MSS-E20R-TC16-1

Shanks



page D2-D9

External modules



page D10-D21

Boring bars

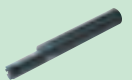

page D23-D25

Internal modules



page D26-D29

Threading



page D30-D35

UTS







page D36-D40

Block - blade



page D41-D45

tools / modules	0°	90°	UTS 0°	UTS 90°	adapter			
see page	 D2	 D3	 D36	 D37	 D5			

D31

# Tools

## TC - monobloc boring bar

TC mono



page D30

TC16



page D31

TC mono

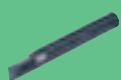

page D32

TC16



page D33

TC milling cutter



page D35

Application	Turning								
-------------	---------	--	--	--	--	--	--	--	--

### TC monobloc boring bar

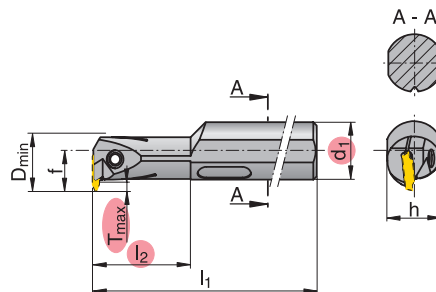

drawing illustrates right hand execution

Bgr.	l <sub>2</sub>	d <sub>1</sub>	type, ordering description	[inch]						threading inserts	page
				f	h	l <sub>1</sub>	T <sub>max</sub>	D <sub>min</sub>			
I16	1.26	.750	R	I16R90-2D-TC16-E	.551	.670	7.00	.16	.79	TC16-1/2 ...	C24/C25
I20	1.57	1.000		I20R90-2D-TC16-E	.689	.905	8.00	.20	.98	TC16- ...	
I25	1.97	1.250		I25R90-2D-TC16-E	.866	1.181	10.00	.24	1.26	TC16- ...	
I16	1.26	.750	L	I16L90-2D-TC16-E	.551	.670	7.00	.16	.79	TC16-1/2 ...	C27/C28
I20	1.57	1.000		I20L90-2D-TC16-E	.689	.905	8.00	.20	.98	TC16- ...	
I25	1.97	1.250		I25L90-2D-TC16-E	.866	1.181	10.00	.24	1.26	TC16- ...	

Bgr. = assembly size

spare parts and accessories	clamping screw	T-key
I16R90-2D-TC16-E I16L90-2D-TC16-E	78 97 203 (M4x14-T15)	78 97 208 (T15)
I20R90-2D-TC16-E I20L90-2D-TC16-E	78 97 205 (M5x18-T20)	78 97 207 (T20)
I25R90-2D-TC16-E I25L90-2D-TC16-E	78 97 206 (M6x20-T25)	78 83 304 (T25)

ordering example: 1 piece I16R90-2D-TC16-E

tools / modules								
see page								



# MSS modules (internal)

## Threading module



Application									
-------------	---	--	--	--	--	--	--	--	--

### TC16



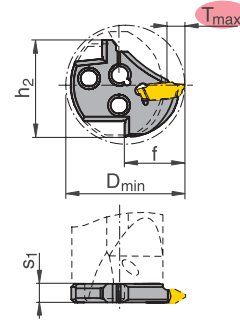

drawing illustrates right hand execution



Bgr.	pitch		$T_{max}$	type, ordering description	[inch]				threading inserts	page	
	mm	T.P.I.			f	$s_1$	$h_2$	$D_{min}$			
I32	0.5 - 1.5	48 - 16	.27	R 	.787	.244	1.268	1.57	TC16-1	C24/C25	
	1.75 - 3.0	14 - 8							TC16-2		
	3.5 - 5.0	7 - 5							MSS-I32N-TC16-3		TC16-3
	0.5 - 1.5	48 - 16	.27	L 	.787	.244	1.268	1.57	TC16-1		C27/C28
	1.75 - 3.0	14 - 8							TC16-2		
	3.5 - 5.0	7 - 5							MSS-I32N-TC16-3		

Bgr. = assembly size

ordering example: 1 piece MSS-I32R-TC16-1

tools / modules	1,5D	2,5D	UTS					
see page	 D24	 D25	 D39					

### Tools

#### Shanks



page D2-D9

#### External modules



page D10-D21

#### Boring bars

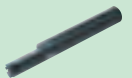

page D23-D25

#### Internal modules



page D26-D29

#### Threading



page D30-D35

#### UTS



page D36-D40

#### Block - blade

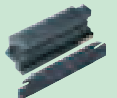

page D41-D45

# Execution

TC mono



page D30

TC16



page D31

TC mono



page D32

TC16



page D33

TC milling cutter



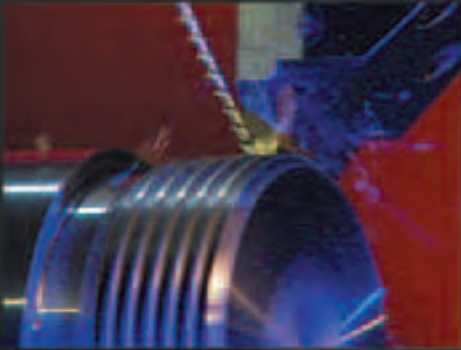

page D35



# Tools

## TC milling cutter

Application									
-------------	---	---	--	--	--	--	--	--	--

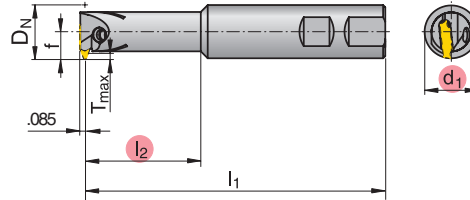

### TC milling cutter



drawing illustrates right hand execution

D <sub>N</sub>	l <sub>2</sub>	d <sub>1</sub>	[mm]						page
			type, ordering description	f	l <sub>1</sub>	T <sub>max</sub>	threading inserts		
.98	2.13	1.000	R 	I25R90-2D-TC16-W-E	.492	5.50	.12	TC16- ...	C26-C29
1.26	2.68	1.250		I32R90-2D-TC16-W-E	.630	6.50	.14	TC16- ...	

ordering example: 1 piece I25R90-2D-TC16-W-E

spare parts and accessories	clamping screw 	T-key 
I25R90-2D-TC16-W-E	78 97 204 (M4,5x17-T20)	78 97 207 (T20)
I32R90-2D-TC16-W-E	78 97 206 (M6x20-T25)	78 83 304 (T25)

tools / modules								
see page								

### Tools

#### Shanks



page D2-D9

#### External modules



page D10-D21

#### Boring bars

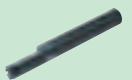

page D23-D25

#### Internal modules



page D26-D29

#### Threading



page D30-D35

#### UTS



page D36-D40

#### Block - blade

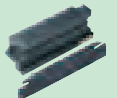

page D41-D45

# Tools

## Modular system (MSS)

UTS 0°



page D36

UTS 90°



page D37

UTS 45°



page D38

UTS GX



page D39

UTS TC



page D40

Application					Turning				
-------------	--	--	--	--	---------	--	--	--	--

UTS 0°

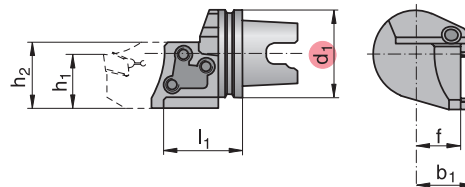

drawing illustrates right hand execution

Bgr.	[mm]	type, ordering description	[inch]					modules
	d <sub>1</sub>		f	b <sub>1</sub>	h <sub>1</sub>	h <sub>2</sub>	l <sub>1</sub>	
E25	40	UT40-MSS-E25R00	.807	1.039	.984	1.181	1.42	MSS-E25R...
	50	UT50-MSS-E25R00	1.004	1.236	.984	1.181	1.653	MSS-E25R...
	63	UT63-MSS-E25R00	1.240	1.472	.984	1.181	1.97	MSS-E25R...
E32	50	UT50-MSS-E32R00	1.004	1.236	1.378	1.646	1.929	MSS-E32R...
	63	UT63-MSS-E32R00	1.240	1.472	1.378	1.646	1.97	MSS-E32R...
	40	UT40-MSS-E25L00	.807	1.039	.984	1.181	1.42	MSS-E25L...
E25	50	UT50-MSS-E25L00	1.004	1.236	.984	1.181	1.653	MSS-E25L...
	63	UT63-MSS-E25L00	1.240	1.472	.984	1.181	1.97	MSS-E25L...
	50	UT50-MSS-E32L00	1.004	1.236	1.378	1.646	1.929	MSS-E32L...
E32	63	UT63-MSS-E32L00	1.240	1.472	1.378	1.646	1.97	MSS-E32L...

Bgr. = assembly size

ordering example: 1 piece UT50-MSS-E25R00





spare parts and accessories	clamping screw	T-key	O-ring
UT40-MSS-E25R00	78 97 205 (M5 x 18 - T20)	78 97 207 (T20)	78 96 900
UT40-MSS-E25L00			78 96 940
UT50-MSS-E25R00			78 96 941
UT50-MSS-E25L00			
UT63-MSS-E25R00			
UT63-MSS-E25L00			78 97 206 (M6 x 20 - T25)
UT63-MSS-E32R00			
UT63-MSS-E32L00			

tools / modules	FX	GX16	GX16	GX24	LX	TC	
see page	D 10/11	D13	D14/15	D16	D17-D20	D21	D31

# Tools

## Modular system (MSS)

Tools



Application					Turning			
-------------	---	---	---	---	---------	--	--	--

### UTS 90°

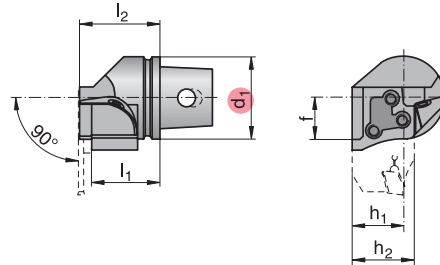

drawing illustrates right hand execution





[mm]		[inch]							
Bgr.	d <sub>1</sub>	type, ordering description	f	h <sub>1</sub>	h <sub>2</sub>	l <sub>1</sub>	l <sub>2</sub>	modules	
E25	40	R 	UT40-MSS-E25R90	.787	.984	1.181	33,5	1.535	MSS-E25L...
	50		UT50-MSS-E25R90	.984	.984	1.181	43,5	1.929	MSS-E25L...
E32	63		UT63-MSS-E32R90	1.063	1.260	1.496	53,5	2.323	MSS-E32L...
E25	40	L 	UT40-MSS-E25L90	.787	.984	1.181	33,5	1.535	MSS-E25R...
	50		UT50-MSS-E25L90	.984	.984	1.181	43,5	1.929	MSS-E25R...
E32	63		UT63-MSS-E32L90	1.063	1.260	1.496	53,5	2.323	MSS-E32R...

Bgr. = assembly size

ordering example: 1 piece UT50-MSS-E25R90



**attention in case of 90°**  
right hand shank - left module  
left hand shank - right module

spare parts and accessories	 clamping screw	 T-key	 O-ring
UT40-MSS-E25L00	78 97 205 (M5 x 18 - T20)	78 97 207 (T20)	78 96 900
UT40-MSS-E25R00			78 96 940
UT50-MSS-E25R00			
UT50-MSS-E25L00	78 97 206 (M6 x 20 - T25)	78 83 304 (T25)	78 96 941
UT63-MSS-E32R00			78 96 941
UT63-MSS-E32L00			

#### Shanks



page D2-D9

#### External modules



page D10-D21

#### Boring bars

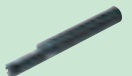

page D23-D25

#### Internal modules



page D26-D29

#### Threading



page D30-D35

#### UTS







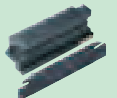

page D36-D40

#### Block - blade



page D41-D45

tools / modules	FX	GX16	GX16	GX24	LX	TC	
							
see page	D 10/11	D13	D14/15	D16	D17-D20	D21	D31

D37

# Tools

## Modular system (MSS)

UTS 0°



page D36

UTS 90°



page D37

UTS 45°



page D38

UTS GX



page D39

UTS TC



page D40

Application									
-------------	--	--	--	--	--	--	--	--	--

UTS 45°

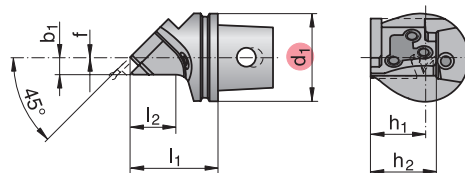

drawing illustrates left hand execution

Bgr.	[mm]	type, ordering description	[inch]							
	d <sub>1</sub>		f	b <sub>1</sub>	h <sub>1</sub>	h <sub>2</sub>	l <sub>1</sub>	l <sub>2</sub>	modules	
E25	40	R	UT40-MSS-E25R45	.0	.315	.984	1.181	1.57	.83	MSS-E25L...
	40	L	UT40-MSS-E25L45	.0	.315	.984	1.181	1.57	.83	MSS-E25R...

Bgr. = assembly size

ordering example: 1 piece UT40-MSS-E25R45

spare parts and accessories	clamping screw	clamping screw short	T-key	O-ring
UT40-MSS-E25L45	78 97 205	78 97 210	78 97 207	78 96 900
UT40-MSS-E25R45	(M5 x 18 - T20)	(M5 x 13,5 - T20)	(T20)	



tools / modules	GX16							
see page	D13							



# Tools

## UTS MSS boring bar

Tools

Application			Turning	Milling					
-------------	---	---	---------	---------	--	--	--	--	--

### UTS boring bar

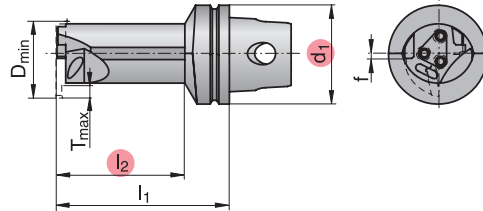





drawing illustrates right hand execution

		[inch]							
Bgr.	l <sub>2</sub>	d <sub>1</sub> [mm]	type, ordering description	f	l <sub>1</sub>	D <sub>min</sub>	T <sub>max</sub>	modules	
116	1.34	40	UT40-MSS-116R90-2D	.039	2.16	.79	.16	MSS-116R...	
120	1.57	40	UT40-MSS-120R90-2D	.039	2.36	.98	.20	MSS-120R...	
125	1.97	40	UT40-MSS-125R90-2D	.059	2.75	1.26	.24	MSS-125R...	
		50	UT50-MSS-125R90-2D		2.95				
132	2.52	40	UT40-MSS-132R90-2D	.079	3.15	1.57	.35	MSS-132R...	
		50	UT50-MSS-132R90-2D		3.54				
		63	UT63-MSS-132R90-2D		3.74				
140	3.15	40	UT40-MSS-140R90-2D	.098	3.62	1.97	.39	MSS-140R...GX16..	
		50	2.36			.75	MSS-140R...GX24..		
			63		1.97	.39	MSS-140R...GX16..		
		2.36			.75	MSS-140R...GX24..			
116	1.34	40	UT40-MSS-116L90-2D	.039	2.16	.79	.16	MSS-116L...	
120	1.57	40	UT40-MSS-120L90-2D	.039	2.36	.98	.20	MSS-120L...	
125	1.97	40	UT40-MSS-125L90-2D	.059	2.75	1.26	.24	MSS-125L...	
		50	UT50-MSS-125L90-2D		2.95				
132	2.52	40	UT40-MSS-132L90-2D	.079	3.15	1.57	.35	MSS-132L...	
		50	UT50-MSS-132L90-2D		3.54				
		63	UT63-MSS-132L90-2D		3.74				
140	3.15	40	UT40-MSS-140L90-2D	.098	3.62	1.97	.39	MSS-140L...GX16..	
		50	2.36			.79	MSS-140L...GX24..		
			63		1.97	.39	MSS-140L...GX16..		
		2.36			.79	MSS-140L...GX24..			

Bgr. = assembly size

ordering example: 1 piece UT40-MSS-116R90-2D

tools / modules	GX09	GX16	GX24	TC				
								
see page	D26/D28	D27/D29	D29	D33				

Shanks



page D2-D9

External modules



page D10-D21

Boring bars

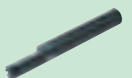

page D23-D25

Internal modules



page D26-D29

Threading



page D30-D35

UTS



page D36-D40

Block - blade

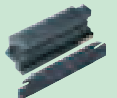

page D41-D45

D39

# Tools

## UTS MSS TC monobloc boring bar

UTS 0°



page D36

UTS 90°



page D37

UTS 45°



page D38

UTS GX



page D39

UTS TC



page D40

FX



page D41

Application	Turning								
-------------	---------	--	--	--	--	--	--	--	--

### TC monobloc boring bars

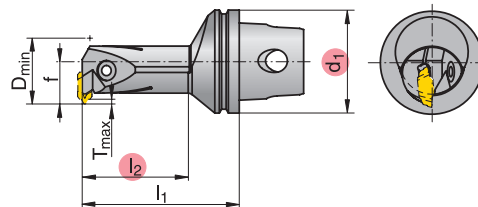

drawing illustrates right hand execution

Bgr.	l <sub>2</sub>	d <sub>1</sub> [mm]	type, ordering description	[mm]					threading inserts	page
				f	l <sub>1</sub>	D <sub>min</sub>	T <sub>max</sub>			
16	1.42	40	R	UT40-MSS-I16R90-2D-TC16	.551	2.16	.79	.16	TC16-1/2 ...	C24 - C28
20	1.57	40		UT40-MSS-I20R90-2D-TC16	.689	2.36	.98	.20	TC16- ...	
25	2.13	40		UT40-MSS-I25R90-2D-TC16	.866	2.75	1.26	.24	TC16- ...	
16	1.42	40	L	UT40-MSS-I16L90-2D-TC16	.551	2.16	.79	.16	TC16-1/2 ...	
20	1.57	40		UT40-MSS-I20L90-2D-TC16	.689	2.36	.98	.20	TC16- ...	
25	2.13	40		UT40-MSS-I25L90-2D-TC16	.866	2.75	1.26	.24	TC16- ...	

Bgr. = assembly size

ordering example: 1 piece UT40-MSS-I16R90-2D-TC16

spare parts and accessories	clamping screw	T-key
UT40-MSS-I16R90-2D-TC16	78 97 203 (M4 x 14 - T15)	78 97 208 (T15)
UT40-MSS-I16L90-2D-TC16		
UT40-MSS-I20R90-2D-TC16	78 97 205 (M5 x 18 - T20)	78 97 207 (T20)
UT40-MSS-I20L90-2D-TC16		
UT40-MSS-I25R90-2D-TC16	78 97 206 (M6 x 20 - T25)	78 83 304 (T25)
UT40-MSS-I25L90-2D-TC16		

tools / modules									
see page									

# Tools

## Blade FX system

Tools

Application									
-------------	--	--	--	--	--	--	--	--	--

### FX blade

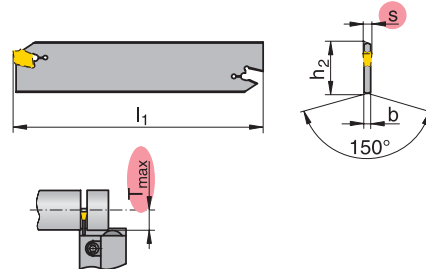

			[inch]				
$h_2$	$s$	$T_{max}$	type, ordering description	$l_1$	$b$	parting inserts	page
1.024	.087	.98	XLCEN 2602 J22 FX	4.33	.065	FX 2.2...	C2 - C6
	.122	1.38	XLCFN 2603 J31 FX		.094	FX 3.1...	
	.161	1.57	XLCFN 2604 J41 FX		.126	FX 4.1...	
1.260	.087	1.18	XLCEN 3202 M22 FX	5.90	.065	FX 2.2...	
	.122	1.97	XLCFN 3203 M31 FX		.094	FX 3.1...	
	.161		XLCFN 3204 M41 FX		.126	FX 4.1...	
	.201	2.16	XLCFN 3205 M51 FX		.157	FX 5.1...	
	.256		XLCFN 3206 M65 FX		.205	FX 6.5...	
1.811	.323	3.15	XLCEN 4608 S82 FX	9.84	.268	FX 8.2...	
	.382		XLCEN 4609 S97 FX		.315	FX 9.7...	

ordering example: 1 piece XLCEN 2602 J22 FX

spare parts and accessories	ejector
XLCEN 2602 J22 FX	78 02 180
XLCEN 3202 M22 FX	
XLCFN 2603 J31 FX	
XLCFN 2604 J41 FX	78 02 181
XLCFN 3203 M31 FX	
XLCFN 3204 M41 FX	
XLCFN 3204 M51 FX	
XLCFN 3206 M65 FX	78 02 182
XLCEN 4608 S82 FX	
XLCEN 4609 S97 FX	

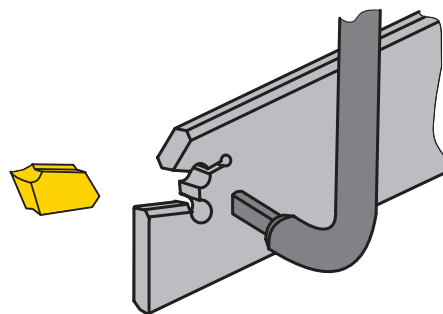

ejector for change of inserts

tools / modules								
see page	D44	D45						

### Shanks



page D2-D9

### External modules



page D10-D21

### Boring bars

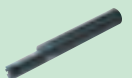

page D23-D25

### Internal modules



page D26-D29

### Threading



page D30-D35

### UTS



page D36-D40

### Block - blade

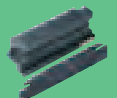

page D41-D45

D41

# Tools

## Blade GX system

FX



page D41

GX



page D42

LX



page D43

SBN...K



page D44

SBN...KS



page D45

Application									
-------------	--	--	--	--	--	--	--	--	--

### GX blade

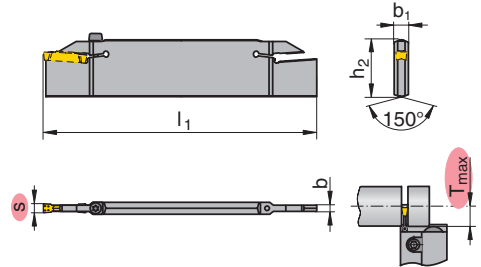

			[inch]					
$h_2$	S	$T_{max}$	type, ordering description	$l_1$	b	$b_1$	inserts	page
1.260	.109 - .148	.83	XLCFN 3203-GX24-2S	7.09	.083	.244	GX24-2...	C11/14
	.148 - .197		XLCFN 3204-GX24-3S		.120		GX24-3...	
	.197 - .256		XLCFN 3206-GX24-4S		.165		GX24-4...	

ordering example: 1 piece XLCFN 3203 GX24-2







spare parts and accessories	clamping screw	T-key	Nm (inlbs)
XLCFN 3203-GX24-2S	78 97 221 (M3,5 x 14 - T15)		≤ 3,3 (29)
XLCFN 3204-GX24-3S			
XLCFN 3206-GX24-4S			

tools / modules	SBN...K	SBN...KS						
see page	D44	D45						

# Tools

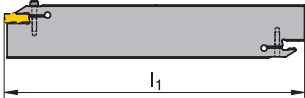
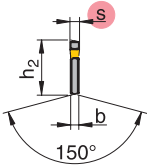
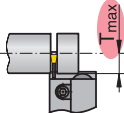
## Blade LX system

Tools

Application									
<b>LX blade</b>    									
			[inch]						
$h_2$	s	$T_{max}$	type, ordering description	$l_1$	b	inserts	page		
1.811	.315	3.15	XLCEN 4608 LX	9.84	.268	LX .....	C7		
ordering example: 1 piece XLCEN 4608 LX									
spare parts and accessories			clamping screw			T-key		Nm (inlbs)	
XLCEN 4608 LX			78 97 218 (M4 x 18 - T20)			78 97 207 (T20)		≤ 4,0 (35,4)	

Shanks



page D2-D9

External modules



page D10-D21

Boring bars



page D23-D25

Internal modules



page D26-D29

Threading



page D30-D35

UTS



page D36-D40

Block - blade

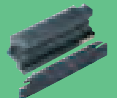

page D41-D45

tools / modules	SBN...K								
see page	 D44								

D43

# Tools

## Clamp block

FX



page D41

GX



page D42

LX



page D43

SBN...K



page D44

SBN...KS



page D45

Application									
-------------	--	--	--	--	--	--	--	--	--

### clamp block

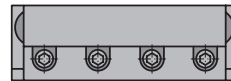
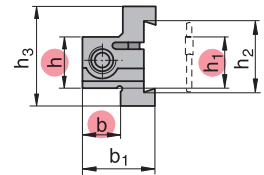
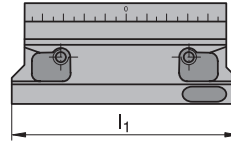

		[inch]					
$h_2$	$h = h_1$	$b$	type, ordering description	$h_3$	$b_1$	$l_1$	blades
1.024	.750	.700	SBN 12-26 K-E	1.535	1.369	3.54	XLC.N 26...
1.260	1.000	.950	SBN 16-32 K-E	1.890	1.647	4.33	XLC.N 32...
	1.250	1.200	SBN 20-32 K-E		1.909	4.72	
1.811	1.250	1.200	SBN 20-46 K-E	2.756	2.105	5.90	XLC.N 46...
	1.500	1.450	SBN 24-46 K-E		2.362		

ordering example: 1 piece SBN 2020-26 K-E

spare parts and accessories	key	clamping screw	coolant set
SBN 12-26 K-E	7812301	7802115	7802148
SBN 16-32 K-E			
SBN 20-32 K-E			
SBN 20-46 K-E	7812302	7802133	7802143



The blocks are delivered without coolant set. When applying integrated coolant supply kindly order the additional coolant set separately.



tools / modules	FX 	GX 	LX 						
see page	D41	D42	D43						



# Tools

## Split clamp block

Tools

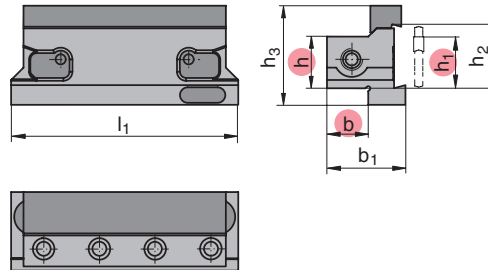

Application									
-------------	---	---	--	--	--	--	--	--	--

### split clamp block





		[inch]					
$h_2$	$h = h_1$	$b$	type, ordering description	$h_3$	$b_1$	$l_1$	blades
1.024	.750	.700	SBN 12-26 KS-E	1.688	1.369	3.54	XLC.N 26...
1.260	1.000	.950	SBN 16-32 KS-E	1.929	1.647	4.33	XLC.N 32...
	1.250	1.200	SBN 20-32 KS-E	2.044	1.909	4.72	

ordering example: 1 piece SBN 2020-26 KS

spare parts and accessories	key 	clamping screw 	coolant set 
SBN 12-26 KS-E	7812301	7802115	7802148
SBN 16-32 KS-E			
SBN 20-32 KS-E			



The blocks are delivered without coolant set. When applying integrated coolant supply kindly order the additional coolant set separately.

tools / modules	FX 	GX 						
see page	D41	D42						

Shanks



page D2-D9

External modules



page D10-D21

Boring bars

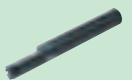

page D23-D25

Internal modules



page D26-D29

Threading

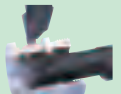

page D30-D35

UTS



page D36-D40

Block - blade

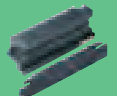

page D41-D45

D45

# Tool setting

## Application recommendations

### center height

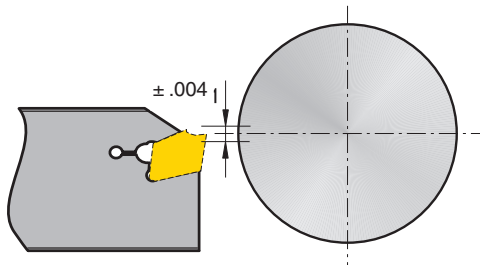

The center height should be set within a tolerance of  $\pm .004$  inch to the work piece axis. This is especially important when parting to center.

### tool setting

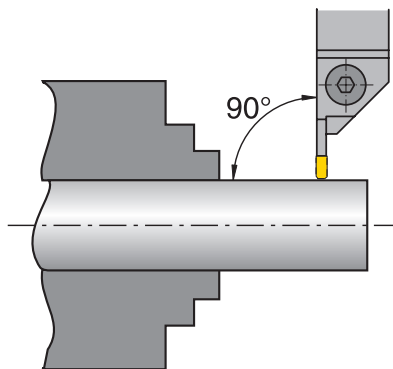

The parting and grooving tool must be mounted with a  $90^\circ$  angle to the axis of the work piece.

### tool overhang

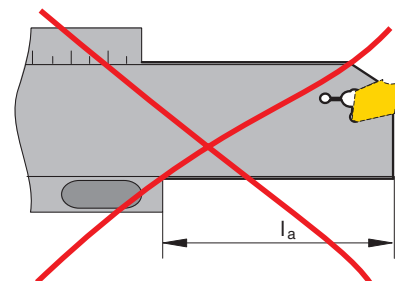
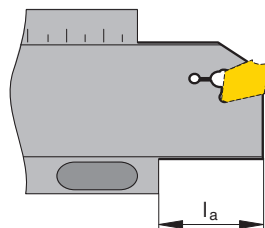

For optimum stability the tool overhang has to be kept as short as possible. The following rule can be applied: overhang  $l_a$  should not be larger than  $8 \times s$  (grooving width).

# Tool setting

## Application recommendations

### work piece overhang

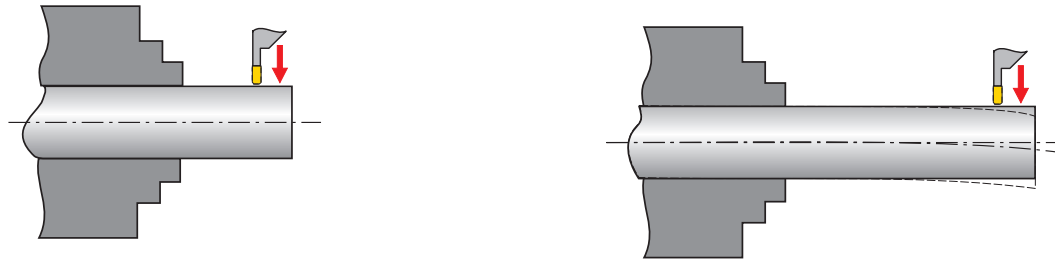

In order to avoid vibrations the work piece should be clamped with the minimum overhang possible.

### parting guidance

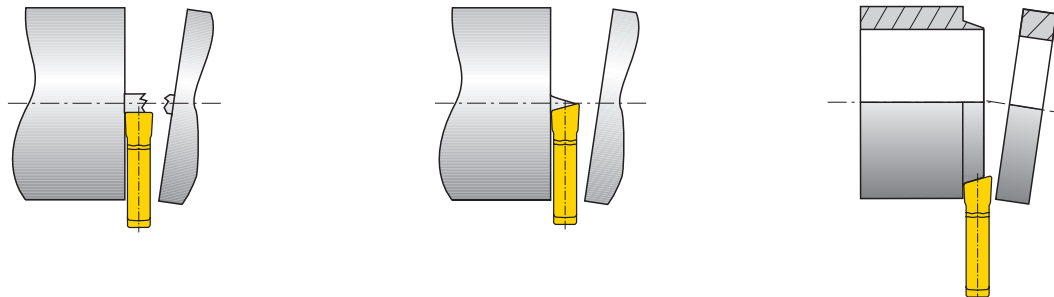

From  $\varnothing .20$  inch on, reduce feed "f" by approx. 50%.

For parting pip-free, use R or L inserts.

In order to prevent ring formation, use R or L inserts.

No parting across centre (risk of breakage).

In order to minimize lateral deflection reduce feed by approx. 20 - 50%.

Reduce feed "f" because of lateral deflection by approx. 20 % - 50%.

### grooving guidance



When grooving with an axial displacement the width "a" should amount to at least 70% of the grooving width "s" .

When grooving oblique surfaces the feed should be reduced by approx. 20% - 50 % at the beginning.

gen.inf.



page E2-E7

-FX

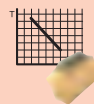

page E8-E13

-GX / -LX

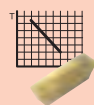

page E14-E24

-LX

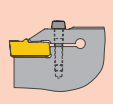

page E25

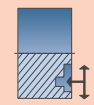

page E26-E29

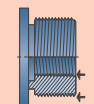

page E30-E39

Special shapes



page E40-E41

Assembly dimensions

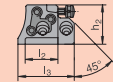

page E42-E43

# Grade overview parting and grooving

Application guidance

page E2-E3

Grade overview

page E4

Problems, solutions

page E5

Cutting data

page E6-E7

Material group acc. to VDI 3323	Application range of cutting material acc. to ISO	Cutting material / grade			
		coated	uncoated	HSS coated	
A Steel	P	10	SR127		
		20	GM127		
		30	SR735	GM40	S40T
		40	GM740		
		50			GMS SM80
R Stainless	M	10	SR127		
		20	GM127		
		30	SR735	GM40	S40T
		40	GM740		GMS SM80
F Cast iron	K	01	SR127		
		10		H216T	TSM20
		20	SR735		
N Non ferrous metals	K	01		AMZ	
		10		H216T	TSM20
		20			
S Heat resistant	M/K	01	SR127		
		10	GM127	AMZ	H216T
		20		GM740	TSM20
		30			
H Hard materials	K	01			
		10	SR127		
		20			
		30			

# Measures in case of problems

## FX parting and grooving system

Problem type										Remedy measures	
wear type				work piece problems				swarf control			
edge break out	built up edge	wear on clearance face	plastic deformation	vibrations	formation of pips and burrs	chattered surface	surface finish	chip too long (snarl chip)	chip too short (fragmented chip)		
	↑	↓	↓	↓			↑	↓		cutting speed	cutting values
↓		~	↓	↑		↓	↓	↑	↓	feed	
↓		↓	↓		↓	↓	↓			feed - centre area	
↑	↓		~	~	↓	↓	↓	↓	↑	chipgroove	selection of indexable inserts
					●					R / L execution	
↑	↑	↑	↑	↓	↓	↓	↑			corner radius	
↓		↑	↑							wear resistance	
				↓		↑	↑			cutting material	
										toughness	
				↓		↑	↑			grooving width	
~				~		~	~			clamping tool	general criteria
~				~		~	~			clamping tool	
~				~			↓			overhang	
~		~		~	~		~			top height	
	●	●	●		●		●	●		cooling lubricant	



raise, increase, large influence



avoid, reduce large influence



check, optimize



raise, increase low influence



avoid, reduce low influence



use

gen. inf



page E2-E7

-FX



page E8-E13

-GX / -LX



page E14-E24

-LX

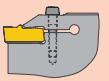

page E25

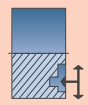

page E26-E29

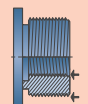

page E30-E39

Special shapes

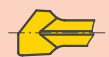

page E40-E41

Assembly dimensions

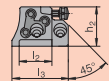

page E42-E43

# Cutting data values

work piece material			hardness	SR127	GM127	
type of treatment / alloy			HB	v <sub>c</sub> [sfpm]	v <sub>c</sub> [sfpm]	
<b>A</b>	non alloyed steel	annealed	≤ 0,15% C	125	492 - 918	492 - 918
		annealed	0,15% - 0,45% C	150-250	426 - 787	426 - 787
		tempered	≥ 0,45% C	300	328 - 656	328 - 656
	low alloy steel	annealed		180	459 - 722	459 - 722
		tempered		250-300	426 - 590	426 - 590
		tempered		350	328 - 525	328 - 525
	high alloy steel	annealed		200	394 - 558	394 - 558
		tempered		350	328 - 492	328 - 492
	corrosion resistant steel	annealed	ferritic	200	492 - 820	492 - 820
		tempered	martensitic	325	197 - 328	197 - 328
<b>R</b>	stainless steel	annealed	ferritic/martensitic	200	459 - 722	459 - 722
		quenched	austenitic	180	394 - 656	394 - 656
		quenched	duplex	230-260	262 - 427	262 - 427
		hardened	ferritic/austenitic	330	197 - 328	197 - 328
<b>F</b>	grey cast iron		perlitic / ferritic	180	394 - 656	—
			perlitic / martensitic	260	328 - 525	—
	SG iron / spheroidal cast iron		ferritic	160	426 - 656	—
			perlitic	250	328 - 525	—
	tempered iron		ferritic	130	394 - 754	—
		perlitic	230	295 - 590	—	
<b>N</b>	malleable aluminum alloys	not hardenable		60	—	—
		hardenable		100	—	—
	cast aluminum alloys	not hardenable	< 12% Si	80	—	—
		hardenable	< 12% Si	90	—	—
		not hardenable	> 12% Si	130	—	—
	copper and copper alloys (bronze, brass)		machining alloy stock (1% Pb)		—	—
			brass, red bronze	90	—	—
			bronze	100	—	—
			lead-free copper and electrolytic copper	100	—	—
	non metal materials		thermosetting plastics		—	—
		fibre-reinforced plastics		—	—	
		hard rubber		—	—	
<b>S</b>	heat resistant alloys	annealed	Fe-base	200	82 - 148	82 - 148
		hardened	Fe-base	280	65 - 131	65 - 131
		annealed	Ni- or Co-base	250	49 - 82	49 - 82
		hardened	Ni- or Co-base	350	33 - 65	33 - 65
		cast	Ni- or Co-base	320	33 - 65	33 - 65
	titanium alloys		pure titanium	R <sub>m</sub> 400*	—	—
			alpha + beta alloys	R <sub>m</sub> 1050*	—	—
<b>H</b>	hardened steel	hardened and tempered		55 HRC	33 - 65	—
		cast		60 HRC	—	—
	hard castings			400	33 - 65	—
	hardened cast iron	hardened and tempered		55 HRC	33 - 65	—

\* R<sub>m</sub> = maximum strength, measured in Mpa



# Cutting data values

Technical information

SR735	GM40	GM740	AMZ	S40T	H216T	TSM20	SM80 GMS
$v_c$ [sfpm]	$v_c$ [sfpm]	$v_c$ [sfpm]	$v_c$ [sfpm]	$v_c$ [sfpm]	$v_c$ [sfpm]	$v_c$ [sfpm]	$v_c$ [fpm]
426 - 722	426 - 722	361 - 492	361 - 525	328 - 525	—	—	
361 - 459	361 - 459	262 - 394	—	230 - 492	—	—	98 - 262
230 - 492	230 - 492	230 - 361	262 - 394	197 - 328	—	—	98 - 230
394 - 623	394 - 623	230 - 328	295 - 426	197 - 361	—	—	—
361 - 492	361 - 492	230 - 295	262 - 394	197 - 295	—	—	98 - 230
230 - 426	230 - 426	197 - 295	230 - 295	197 - 262	—	—	—
295 - 459	295 - 459	197 - 262	295 - 459	197 - 262	—	—	—
230 - 426	230 - 426	197 - 262	230 - 295	197 - 262	—	—	—
394 - 656	394 - 656	295 - 426	525 - 722	262 - 426	—	—	—
197 - 262	197 - 262	197 - 262	230 - 361	197 - 328	—	—	98 - 262
—	394 - 656	328 - 590	525 - 722	—	—	—	—
—	328 - 558	262 - 495	361 - 525	—	—	—	98 - 262
—	230 - 361	230 - 361	—	—	—	—	98 - 262
—	197 - 295	197 - 295	230 - 361	—	—	—	—
—	—	—	590 - 722	—	361 - 590	328 - 590	—
—	—	—	459 - 590	—	295 - 492	295 - 492	—
—	—	—	525 - 656	—	361 - 590	328 - 558	—
—	—	—	394 - 590	—	262 - 459	230 - 426	—
—	—	—	590 - 787	—	328 - 656	295 - 590	—
—	—	—	525 - 656	—	230 - 525	230 - 492	—
—	—	—	328 - 3280	—	328 - 3040	328 - 3040	—
—	—	—	328 - 2624	—	262 - 3040	262 - 3040	98 - 984
—	—	—	328 - 1640	—	262 - 1640	262 - 3040	262 - 3040
—	—	—	328 - 1640	—	—	—	262 - 3040
—	—	—	328 - 1640	—	—	—	—
—	—	—	262 - 984	—	262 - 984	262 - 984	98 - 656
—	—	—	—	—	656 - 1968	492 - 1968	—
—	—	—	—	—	492 - 1520	328 - 984	164 - 394
—	—	—	—	—	328 - 984	262 - 984	164 - 328
—	—	—	262 - 1640	—	262 - 1640	262 - 1640	—
—	—	—	262 - 656	—	197 - 492	164 - 492	262 - 1640
—	—	—	—	—	328 - 820	328 - 820	—
—	—	—	98 - 164	—	—	98 - 131	164 - 492
—	—	65 - 131	82 - 115	—	—	82 - 115	—
—	—	65 - 98	49 - 82	—	—	49 - 82	—
—	—	—	33 - 65	—	—	33 - 65	—
—	—	—	33 - 82	—	—	33 - 65	—
—	—	—	—	—	295 - 459	328 - 459	—
—	—	—	—	—	98 - 197	131 - 197	—
—	—	—	—	—	—	—	—
—	—	—	—	—	—	—	—
—	—	—	—	—	—	—	—
—	—	—	—	—	—	—	—

gen.inf.



page E2-E7

-FX

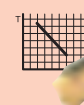

page E8-E13

-GX / -LX



page E14-E24

-LX



page E25

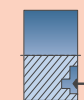

page E26-E29

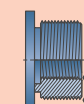

page E30-E39

Special shapes



page E40-E41

Assembly dimensions



page E42-E43

# The easy way to success

## Application recommendations

### FX ...-F1

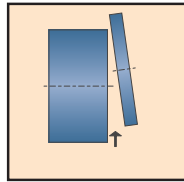

- ⇒ excellent cutting geometry with low cutting forces
- ⇒ for low or medium strength materials
- ⇒ particularly suitable for parting off tubes and thin-walled work pieces
- ⇒ excellent swarf control also with low feed
- ⇒ low built up edge

application:

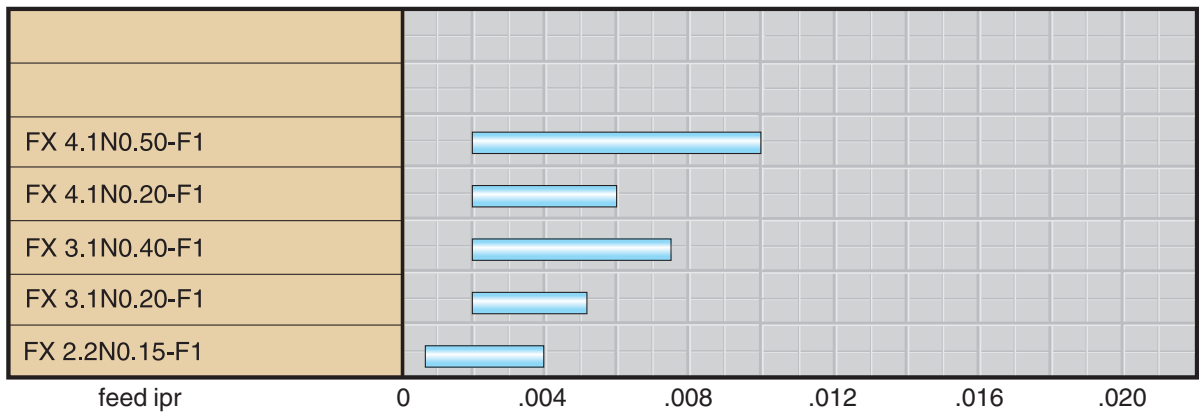

**Attention:** reduce feed by 20%-50% for R/L execution!

	parting			grooving	grooving and turning
	tubes	bars	difficult conditions		
Steel	SR127 / SR735 GM740	SR735 / GM740	—	SR127 / SR735 GM740	—
Stainless	SR735 / GM740	SR735 / GM740	—	SR735 / GM740	—
Cast iron	SR127	SR127	—	SR127	—
Non ferrous metals	—	—	—	—	—
Heat resistant	—	—	—	—	—
Hard materials	—	—	—	—	—



# The easy way to success

## Application recommendations

### FX ...-M1

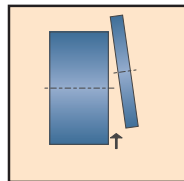

- ⇒ insert with narrow negative chamfer
- ⇒ suitable for all steel materials with high strength
- ⇒ suitable for all applications
- ⇒ for steel and grey cast iron

application:

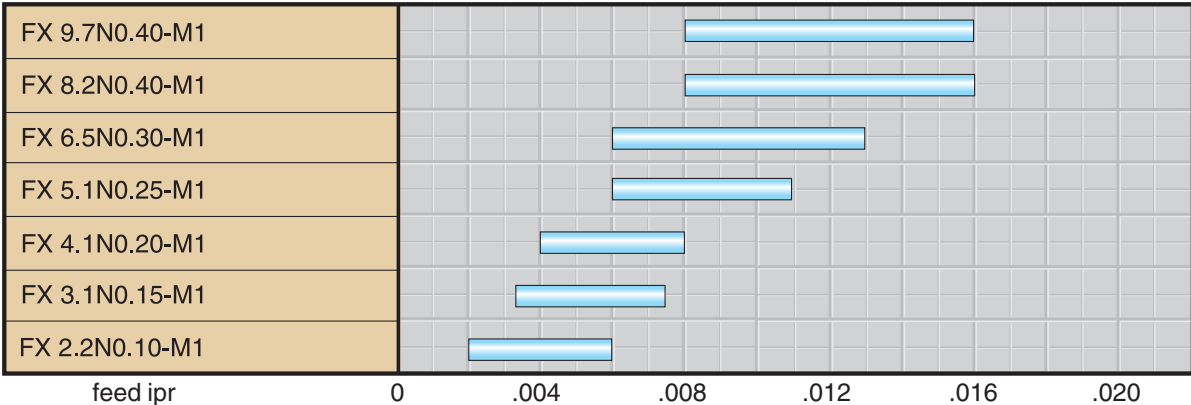

**Attention:** reduce feed by 20%-50% for R/L execution!

	parting			grooving	grooving and turning
	tubes	bars	difficult conditions		
Steel	SR127 / SR735	SR127 / GM40 SR735 / GM740	GM740	SR127 / SR735 GM40	—
Stainless	SR735 / GM740	SR735 / GM740	GM740	SR735 / GM740	—
Cast iron	SR127	SR127	SR735	SR127	—
Non ferrous metals	—	—	—	—	—
Heat resistant	GM740	GM740	—	GM740	—
Hard materials	—	—	—	SR127	—

gen.inf.



page E2-E7

-FX

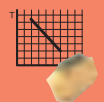

page E8-E13

-GX / -LX



page E14-E24

-LX

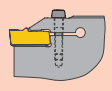

page E25

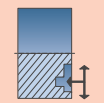

page E26-E29

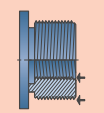

page E30-E39

Special shapes

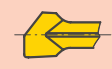

page E40-E41

Assembly dimensions

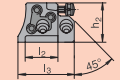

page E42-E43

# The easy way to success!

## Application recommendations

### FX ...-R1

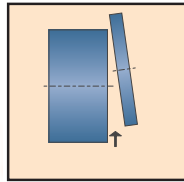

- ⇒ insert with **very stable cutting edge** for roughing
- ⇒ when using inserts with large corner radii high feeds are possible
- ⇒ particularly suitable for parting off thick-walled tubes
- ⇒ for medium or high strength steels

application:

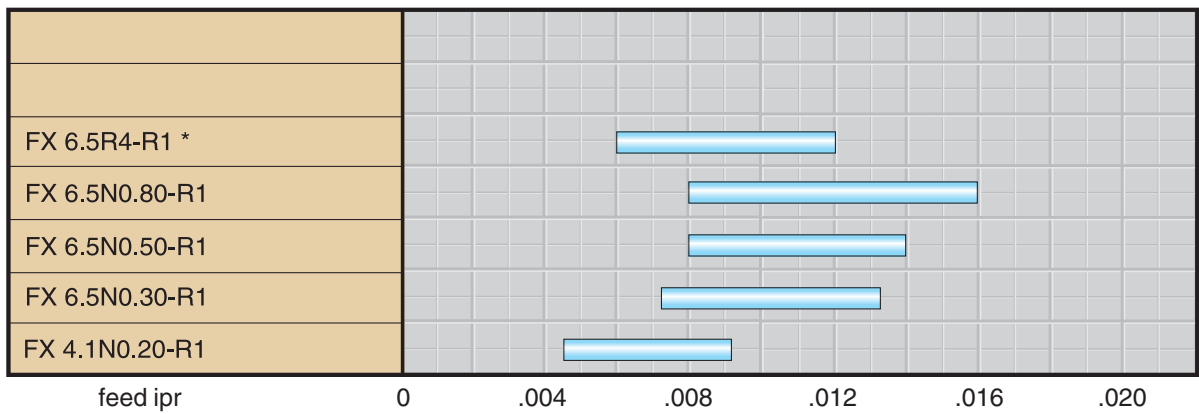

\* R4 = right insert 4°

	parting			grooving	grooving and turning
	tubes	bars	difficult conditions		
Steel	GM740 / GM40	GM740 / GM40	GM740	GM740 / GM40	—
Stainless	GM740	GM740	GM740	GM740	—
Cast iron	—	—	—	—	—
Non ferrous metals	—	—	—	—	—
Heat resistant	GM740	GM740	GM740	GM740	—
Hard materials	—	—	—	—	—



# The easy way to success

## Application recommendations

### FX ...-R2

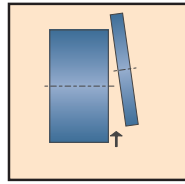

- ⇒ insert with excellent chip formation for a wide feed range
- ⇒ very stable cutting edge
- ⇒ particularly suitable for economic parting when rather intensive formation of burrs and pips does not cause disturbances

application:

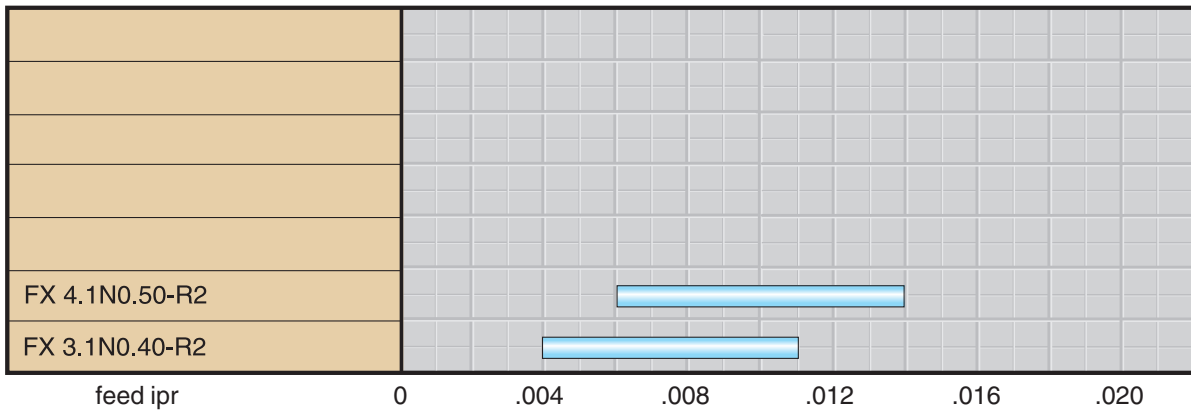

	parting			grooving	grooving and turning
	tubes	bars	difficult conditions		
Steel	SR127 / SR735 GM740	SR735 / GM740	GM740	SR127 / SR735 GM740	—
Stainless	GM740	GM740	GM740	SR735 / GM740	—
Cast iron	SR127	SR127	SR127	SR127	—
Non ferrous metals	—	—	—	—	—
Heat resistant	GM740	GM740	GM740	GM740	—
Hard materials	—	—	—	—	—

gen.inf.



page E2-E7

-FX



page E8-E13

-GX / -LX



page E14-E24

-LX

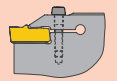

page E25

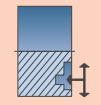

page E26-E29

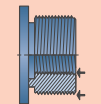

page E30-E39

Special shapes



page E40-E41

Assembly dimensions

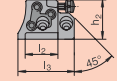

page E42-E43

# The easy way to success

## Application recommendations

### FX ...-27P

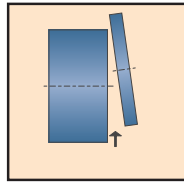

- ⇒ particularly suitable for **aluminum and non ferrous metals**
- ⇒ insert with highly positive cutting geometry and sharp cutting edge
- ⇒ extra-smooth rake face through "microfinish"
- ⇒ reduced built up edge

application:

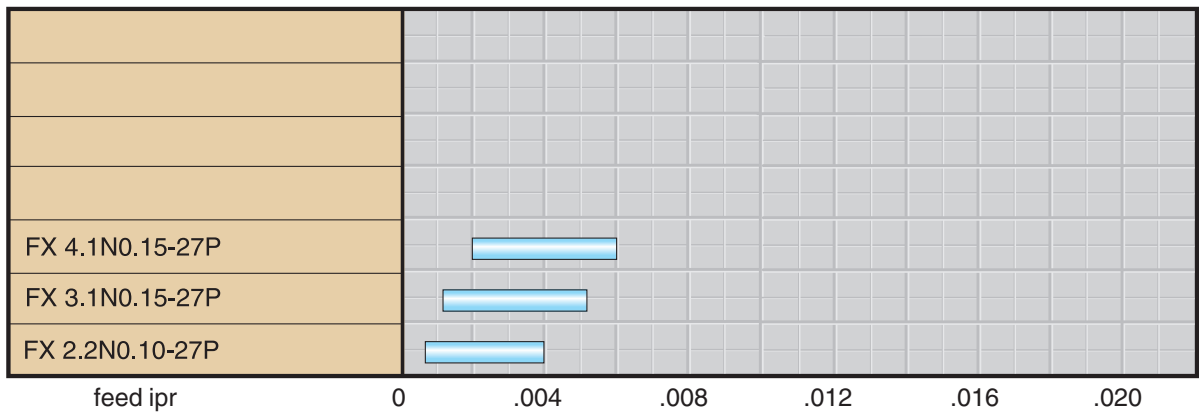

	parting			grooving	grooving and turning
	tubes	bars	difficult conditions		
Steel	—	—	—	—	—
Stainless	—	—	—	—	—
Cast iron	—	—	—	—	—
Non ferrous metals	H216T	H216T	H216T	H216T	—
Heat resistant	—	—	—	—	—
Hard materials	—	—	—	—	—





# The easy way to success

## Application recommendations

### FX ...-F9

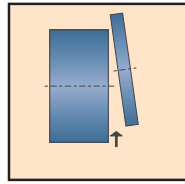

- ⇒ coated HSS insert (SM80)
- ⇒ only applicable with **low cutting speeds** (steel materials  $v_c = 80 - 180$  fpm)
- ⇒ **wet machining only!**
- ⇒ for all steel materials  $< 230$  HB
- ⇒ problem solver for materials which tend to extreme built up edge

application:

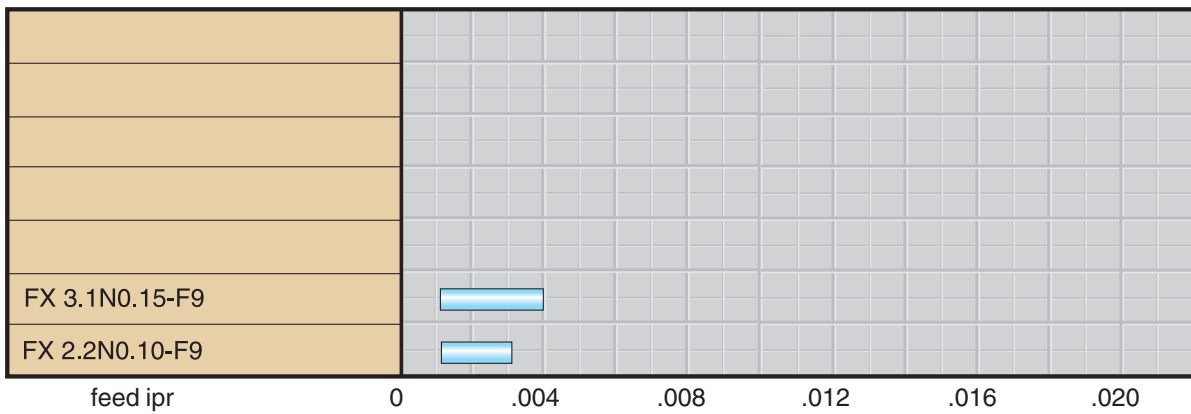

**Attention:** reduce feed by 20-50% for R/L executions!

	parting			grooving	grooving and turning
	tubes	bars	difficult conditions		
Steel	SM80	SM80	SM80	SM80	—
Stainless	SM80	SM80	SM80	SM80	—
Cast iron	—	—	—	—	—
Non ferrous metals	—	—	—	—	—
Heat resistant	SM80	SM80	—	SM80	—
Hard materials	—	—	—	—	—

gen.inf.



page E2-E7

-FX



page E8-E13

-GX / -LX



page E14-E24

-LX

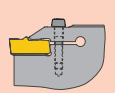

page E25

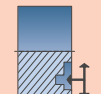

page E26-E29

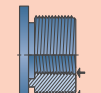

page E30-E39

Special shapes



page E40-E41

Assembly dimensions

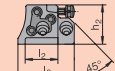

page E42-E43

# The easy way to success

## Application recommendations

GX09/16  
Standard

page E14

GX09/16  
-M4

page E15

GX16  
-27P

page E16

-GX24

page E17-E20

Circlips

page E22

Radius  
inserts

page E23

-LX

page E24







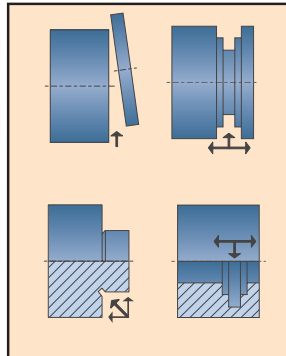



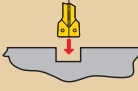
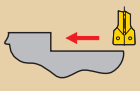

### GX09 / 16... standard



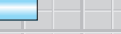



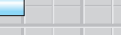



application:



- ⇒ peripherally ground insert
- ⇒ tolerance **parting and grooving**  
**width ± .0008 inch**
- ⇒ for all steel materials
- ⇒ also suitable for parting off thin-walled  
work pieces
- ⇒ special shapes possible

type, ordering description	 f [ipr]	 f [ipr]	a <sub>max</sub> [Inch]
GX16-4E(5.01-6.50)N..			.157
GX16-3E(3.76-5.00)N..			.138
GX16-2E(2.76-3.75)N..			.118
GX16-1E(2.00-2.75)N			.079
GX09-2E(2.76-3.75)N..			.079
GX09-1E(2.00-2.75)N..			.059

feed ipr      0 .004 .008 .012 .016 .020      0 .008 .016 .024 .031 .039

	parting			grooving	grooving and turning
	tubes	bars	difficult conditions		
					
Steel	SR127 / GM127	—	—	SR127 / GM127	SR127 / GM127
Stainless	GM127	—	—	GM127	GM127
Cast iron	SR127	—	—	SR127	SR127
Non ferrous metals	—	—	—	—	—
Heat resistant	—	—	—	—	—
Hard materials	—	—	—	—	—

# The easy way to success

## Application recommendations

Technical information

### GX09 / 16...-M4



application:

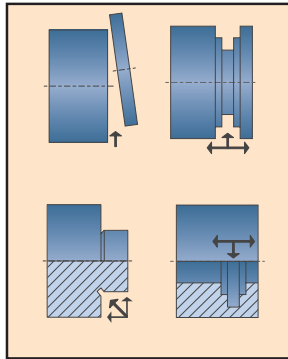
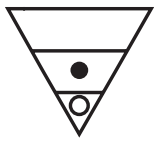

- ⇒ for grooving and turning
- ⇒ suitable for all steel materials
- ⇒ very good swarf control
- ⇒ tolerance grooving width  $\pm .0020$  inch

type, ordering description	f [ipr]		$a_{max}$ [Inch]
GX16-4E6.0N0.50-M4			.157
GX16-3E5.0N0.40-M4			.138
GX16-3E4.0N0.40-M4			.118
GX16-2E3.0N0.30-M4			.118
GX16-1E2.0N0.20-M4			.079
GX09-2E3.0N0.30-M4			.079
GX09-1E2.0N0.20-M4			.059

feed ipr                      0 .004 .008 .012 .016 .020    0 .008 .016 .024 .031 .039

	parting			grooving	grooving and turning
	tubes	bars	difficult conditions		
Steel	SR735 / GM740	—	—	SR127 / SR735 GM740	SR735 / GM740
Stainless	GM740	—	—	GM740	GM740
Cast iron	SR127	—	—	SR127	SR127
Non ferrous metals	—	—	—	—	—
Heat resistant	GM740	—	—	GM740	GM740
Hard materials	—	—	—	—	—

gen.inf.



page E2-E7

-FX



page E8-E13

-GX / -LX



page E14-E24

-LX

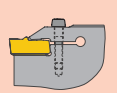

page E25

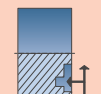

page E26-E29

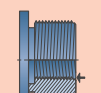

page E30-E39

Special shapes



page E40-E41

Assembly dimensions

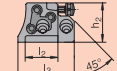

page E42-E43

# The easy way to success

## Application recommendations

### GX16...-27P



application:

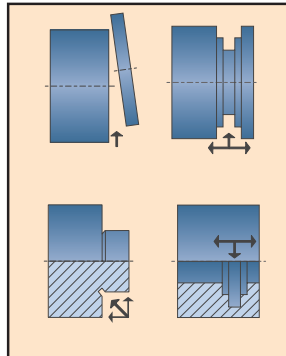

- ⇒ particularly suitable for **aluminum and non ferrous metals**
- ⇒ insert with highly positive cutting geometry and sharp cutting edge
- ⇒ peripherally ground
- ⇒ tolerance grooving width  $\pm .0008$  inch
- ⇒ extra-smooth rake face through "microfinish"

GX09/16  
Standard



page E14

GX09/16  
-M4



page E15

GX16  
-27P



page E16

-GX24



page E17-E20

Circlips



page E22

Radius  
inserts











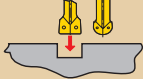
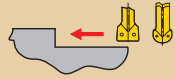

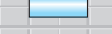

page E23

-LX



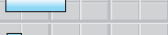



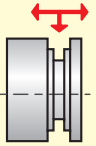

page E24

type, ordering description	 f [ipr]	 f [ipr]	$a_{max}$ [Inch]
			.157
			.118
GX16-3R2.5N-27P			.098
GX16-3R2.0N-27P			.079
GX16-2R1.5N-27P			.059
GX16-4E6.00N0.50-27P			.157
GX16-3E4.00N0.40-27P			.138
GX16-2E3.00N0.30-27P			.118
GX16-1E2.00N0.20-27P			.079

feed ipr

0 .004 .008 .012 .016 .020 0 .008 .016 .024 .031 .039

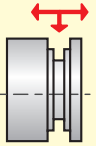
	parting			grooving	grooving and turning
	tubes	bars	difficult conditions		
					
Steel	—	—	—	—	—
Stainless	—	—	—	—	—
Cast iron	—	—	—	—	—
Non ferrous metals	H216T	—	—	H216T	H216T
Heat resistant	H216T	—	—	H216T	H216T
Hard materials	—	—	—	—	—

# The easy way to success

## Application recommendations

Technical information

### GX24...-27P



application:

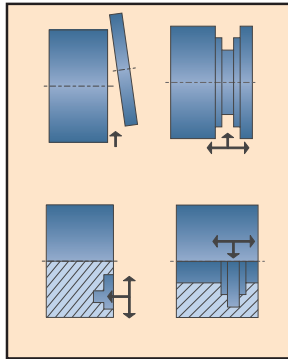

- ⇒ for all steel materials
- ⇒ suitable for all applications
- ⇒ wide application range
  - parting  $T_{max} = .83$  inch
  - grooving and turning
  - axial grooving
  - internal grooving  $T_{max} = .75$  inch

type, ordering description	f [ipr]	f [ipr]	$a_{max}$ [Inch]
GX24-5R4.00N-27P			.157
GX24-4R3.00N-27P			.118
GX24-4E6.00N0.50-27P			.157
GX24-3E5.00N0.40-27P			.138
GX24-3E4.00N0.40-27P			.118
GX24-2E3.00N0.30-27P			.098

feed ipr                      0 .004 .008 .012 .016 .020    0 .008 .016 .024 .031 .039

	parting			grooving	grooving and turning
	tubes	bars	difficult conditions		
Steel	—	—	—	—	—
Stainless	—	—	—	—	—
Cast iron	—	—	—	—	—
Non ferrous metals	H216T / TSM20	—	—	H216T / TSM20	H216T / TSM20
Heat resistant	H216T / TSM20	—	—	H216T / TSM20	H216T / TSM20
Hard materials	—	—	—	—	—

gen.inf.



page E2-E7

-FX

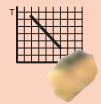

page E8-E13

-GX / -LX



page E14-E24

-LX

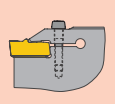

page E25

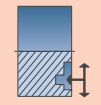

page E26-E29

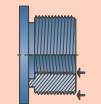

page E30-E39

Special shapes



page E40-E41

Assembly dimensions

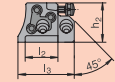

page E42-E43

# The easy way to success

## Application recommendations

GX09/16  
Standard

page E14

GX09/16  
-M4

page E15

GX16  
-27P

page E16

-GX24

page E17-E20

Circlips

page E22

Radius  
inserts

page E23

-LX

page E24

### GX24... standard



application:

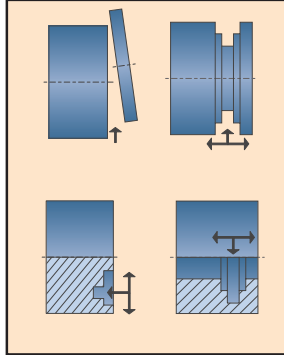

- ⇒ for all steel materials
- ⇒ suitable for all applications
- ⇒ wide application range
  - parting  $T_{max} = .83$  inch
  - grooving and turning
  - axial grooving
  - internal grooving  $T_{max} = .75$  inch

type, ordering description	f [ipr]	f [ipr]	a <sub>max</sub> [Inch]
GX24-4E6.00N0.50			.138
GX24-3E5.00N0.40			.118
GX24-3E4.00N0.40			.118
GX24-2E3.00N0.30			.098

feed ipr

0 .004 .008 .012 .016 .020 0 .008 .016 .024 .031 .039

	parting			grooving	grooving and turning
	tubes	bars	difficult conditions		
	SR127 / GM40	GM40	—	SR127 / GM40	SR127 / GM40
	GM40	GM40	—	GM40	GM40
	SR127	SR127	—	SR127	SR127
	—	—	—	—	—
	—	—	—	—	—
	—	—	—	—	—



# The easy way to success

## Application recommendations







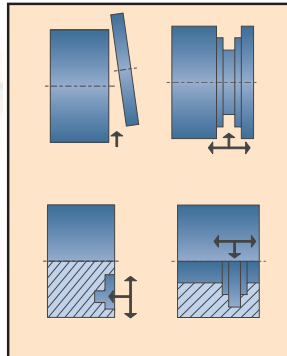







### GX 24...-F2

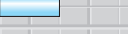

application:

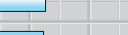

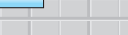



- ⇒ For steels in general, particularly suitable for **stainless materials**
- ⇒ Insert with ground periphery
- ⇒ Tolerance parting and grooving width  $\pm .0008$  inch
- ⇒ Suitable also for parting off tubes and thin-walled materials
- ⇒ Special profiles possible

type, ordering description	 f [ipr]	 f [ipr]	$a_{max}$ [Inch]
GX24-4E6.00N0.50-F2			.157
GX24-3E5.00N0.40-F2			.138
GX24-3E4.50N0.40-F2			.118
GX24-3E4.00N0.40-F2			.118
GX24-2E3.50N0.30-F2			.098
GX24-2E3.00N0.30-F2			.098

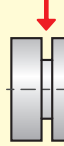
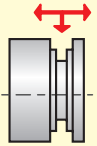
feed ipr

0 .004 .008 .012 .016 .020 0 .008 .016 .024 .031 .039

	parting			grooving	grooving and turning
	tubes	bars	difficult conditions		
				SR127 / SR735 GM740	SR735 / GM740
Steel	SR735 / GM740	SR735 / GM740	—	SR127 / SR735 GM740	SR735 / GM740
Stainless	GM740	GM740	—	GM740	GM740
Cast iron	SR127	SR127	—	SR127	SR127
Non ferrous metals	—	—	—	—	—
Heat resistant	GM740	—	—	GM740	GM740
Hard materials	—	—	—	—	—

Technical information

gen.inf.



page E2-E7

-FX



page E8-E13

-GX / -LX



page E14-E24

-LX

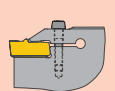

page E25

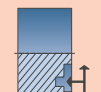

page E26-E29

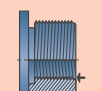

page E30-E39

Special shapes



page E40-E41

Assembly dimensions

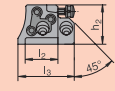

page E42-E43

E19

# The easy way to success

## Application recommendations

GX09/16  
Standard



page E14

GX09/16  
-M4



page E15

GX16  
-27P



page E16

-GX24



page E17-E20

Circlips



page E22

Radius  
inserts



page E23

-LX



page E24







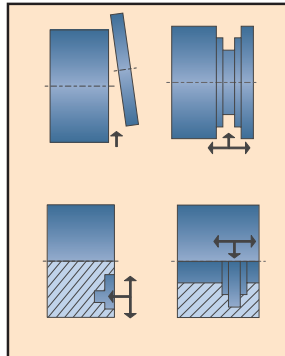

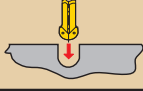
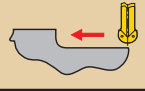

### GX24...-M3

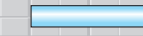

application:







- ⇒ Inserts for **full radius grooves** and for copy turning
- ⇒ For all steel materials
- ⇒ For internal and external machining

type, ordering description	 f [ipr]	 f [ipr]	 a <sub>max</sub> [Inch]
GX24-4R3.00N-M3			.138
GX24-3R2.00N-M3			.098
GX24-3R2.50N-M3			.118
GX24-2R1.50N-M3			.059

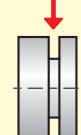
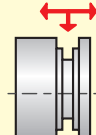
feed ipr

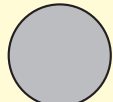
0 .004 .008 .012 .016 .020 0 .008 .016 .024 .031 .039

	parting			grooving	grooving and turning
	tubes	bars	difficult conditions		
				SR127 / SR735	SR127 / SR735
Steel	—	—	—	SR127 / SR735	SR127 / SR735
Stainless	—	—	—	SR735	SR735
Cast iron	—	—	—	SR127	SR127
Non ferrous metals	—	—	—	—	—
Heat resistant	—	—	—	—	—
Hard materials	—	—	—	—	—

gen.inf.



page E2-E7

-FX



page E8-E13

-GX / -LX



page E14-E24

-LX

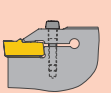

page E25



page E26-E29



page E30-E39

Special  
shapes



page E40-E41

Assembly  
dimensions

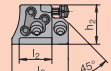

page E42-E43



# The easy way to success

## Application recommendations

### GX09 / 16...S...

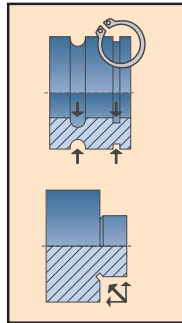

- ⇒ inserts for **circlip grooves** according to DIN 471-472
- ⇒ for internal and external grooves

application:



GX09/16  
Standard

page E14

GX09/16  
-M4

page E15

GX16  
-27P

page E16

-GX24

page E17-E20

**Circlips**











page E22

**Radius inserts**

page E23





-LX

page E24

type, ordering description	 f [ipr]	 f [ipr]	 a <sub>max</sub> [Inch]
GX16-4S5.25N			
GX16-3S4.25N			
GX16-2S(2.75/3.25)N			
GX16-2S(0.60-2.25)R/L			
GX09-2S(2.75/3.25)N			
GX09-1S(1.95/2.25)N			
GX09-1S(0.60-1.70)R/L			

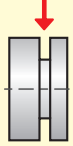
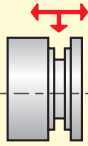
feed ipr

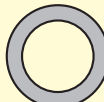
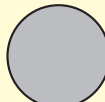
0 .004 .008 .012 .016 .020 0 .008 .016 .024 .031 .039

	parting			grooving	grooving and turning
	tubes	bars	difficult conditions		
				SR127	—
Steel	—	—	—	SR127	—
Stainless	—	—	—	SR127	—
Cast iron	—	—	—	SR127	—
Non ferrous metals	—	—	—	SR127	—
Heat resistant	—	—	—	SR127	—
Hard materials	—	—	—	—	—

# The easy way to success

## Application recommendations

### GX 09 / 16...R...





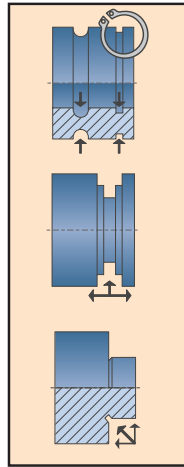

application:

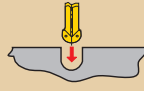
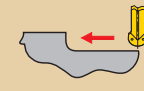

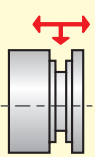
- ⇒ inserts for **full radius grooves** and for copy turning
- ⇒ for all steel materials
- ⇒ for internal and external machining

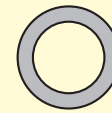
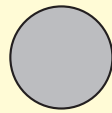
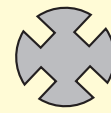
type, ordering description	 f [ipr]	 f [ipr]	$a_{max}$ [Inch]
GX16-4R3.00N			.118
GX16-3R2.50N			.098
GX16-3R2.00N			.079
GX16-2R1.50N			.059
GX16-2R(0.8-1.2)R/L			.047
GX09-1R(1.0/1.2)N			.039
GX09-1R0.8R/L			
feed ipr	0 .004 .008 .012 .016 .020	0 .008 .016 .024 .031 .039	

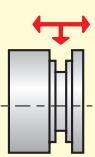
	parting			grooving	grooving and turning
	tubes	bars	difficult conditions		
					
Steel	—	—	—	SR127	SR127
Stainless	—	—	—	SR127	SR127
Cast iron	—	—	—	SR127	SR127
Non ferrous metals	—	—	—	SR127	SR127
Heat resistant	—	—	—	SR127	SR127
Hard materials	—	—	—	—	—

Technical information

gen.inf.



page E2-E7

-FX



page E8-E13

-GX / -LX



page E14-E24

-LX

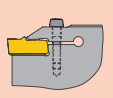

page E25



page E26-E29



page E30-E39

Special shapes



page E40-E41

Assembly dimensions

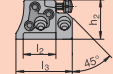

page E42-E43

E23



# The easy way to success

## Application recommendations

GX09/16  
Standard



page E14

GX09/16  
-M4



page E15

GX16  
-27P



page E16

-GX24



page E17-E20

Circlips



page E22

Radius  
inserts



page E23

-LX



page E24

-LX



page E25



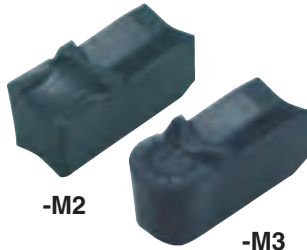

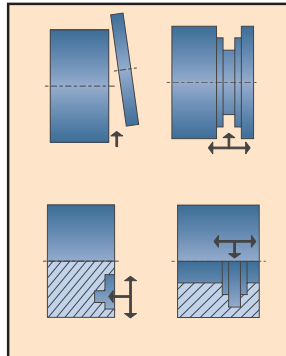

### LX ... -M2 / -M3



application:

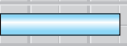



- ⇒ grooving width .315 inch
- ⇒ the system can be applied universally for
  - parting off
  - grooving and turning
  - axial grooving from  $\varnothing$  19.68 inch up
  - internal grooving and turning, from  $\varnothing$  7.87 inch up
- ⇒ suitable for all steel materials

type, ordering description	 f [ipr]	 f [ipr]	$a_{max}$ [Inch]
LX R4.00N-M3			.157
LX E8.00N0.80-M2			.197

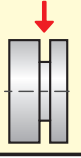
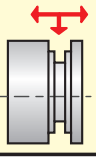

feed ipr

0 .004 .008 .012 .016 .020 0 .008 .016 .024 .031 .039

	parting			grooving	grooving and turning
	tubes	bars	difficult conditions		
	SR127 / SR735	SR127 / SR735	SR735	SR127 / SR735	SR127 / SR735
Steel	SR127 / SR735	SR127 / SR735	SR735	SR127 / SR735	SR127 / SR735
Stainless	SR735	SR735	SR735	SR735	SR735
Cast iron	SR127	SR127	SR127	SR127	SR127
Non ferrous metals	—	—	—	—	—
Heat resistant	—	—	—	—	—
Hard materials	—	—	—	—	—

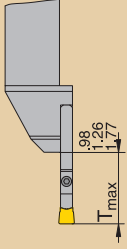
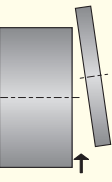
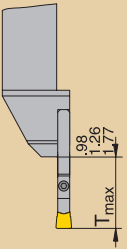
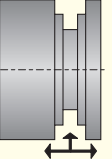
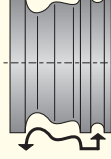
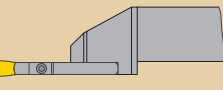
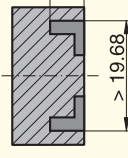
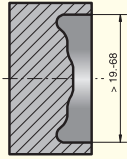
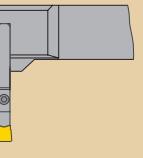
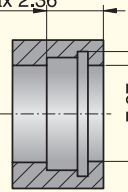
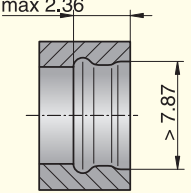

# LX application possibilities

<div style="text-align: right;">insert</div> <div style="text-align: left;">application</div>		
<p><b>parting</b></p> 		
<p><b>grooving / turning</b></p> 		
<p><b>axial grooving</b></p> 	<p> <math>T_{max}</math>            .748 - MSS-E32N25-LX            1.024 - MSS-E32N32-LX            1.585 - MSS-E32N45-LX         </p> 	
<p><b>internal grooving / turning</b></p>  <p>for this type of internal machining the external tool MSS-E32R/L90-3225N is used</p>	<p> <math>T_{max}</math>            max 2,36            .551 - MSS-E32N25-LX            .827 - MSS-E32N32-LX            1,338 - MSS-E32N45-LX         </p> 	

gen.inf.



page E2-E7

-FX

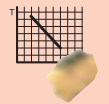

page E8-E13

-GX / -LX

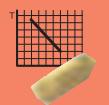

page E14-E24

-LX



page E25

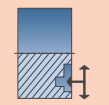

page E26-E29

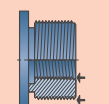

page E30-E39

Special shapes



page E40-E41

Assembly dimensions

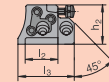

page E42-E43

# Application possibilities

Application possibilities

pag. E26-E27

Machining guidance

pag. E28-E29

## tool configuration

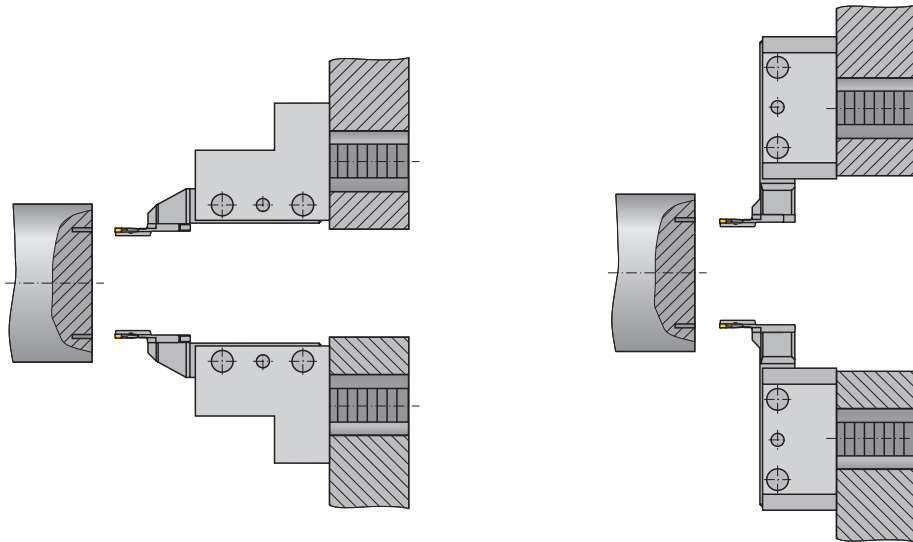

### MSS tool 0°

- ⇒ large overhang
- ⇒ danger of collision
- ⇒ special VDI shank necessary

### MSS tool 90°

- ⇒ short overhang
- ⇒ increased stability
- ⇒ normal clamping in VDI shank possible

## grooving depths

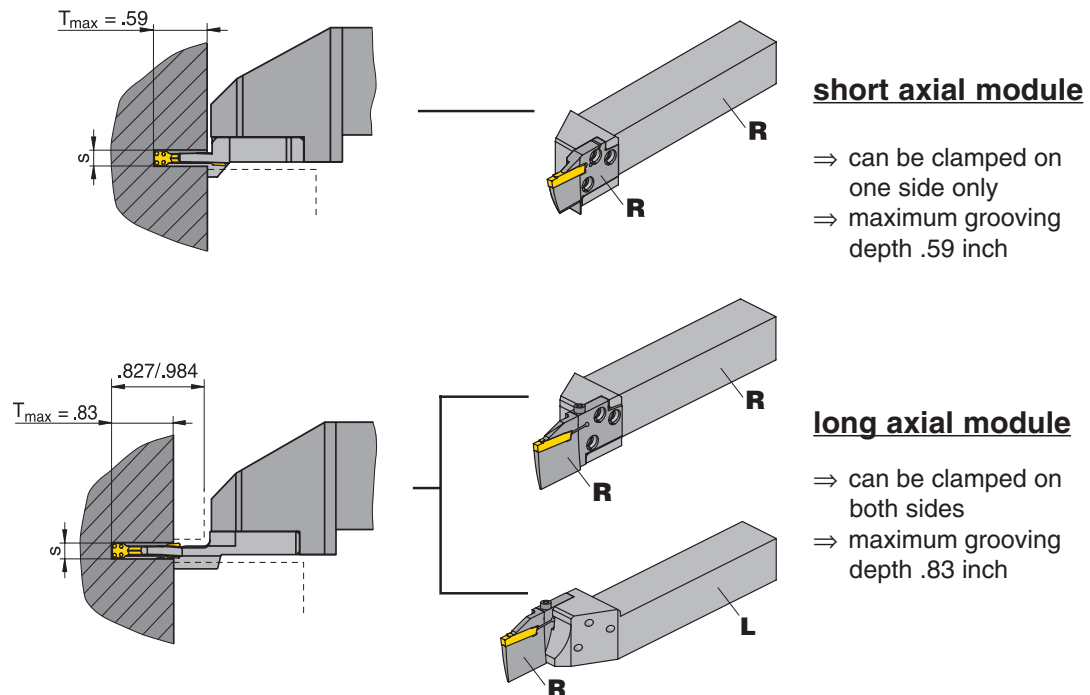

### short axial module

- ⇒ can be clamped on one side only
- ⇒ maximum grooving depth .59 inch

### long axial module

- ⇒ can be clamped on both sides
- ⇒ maximum grooving depth .83 inch

# Application possibilities

## machining possibilities with short/long axial module

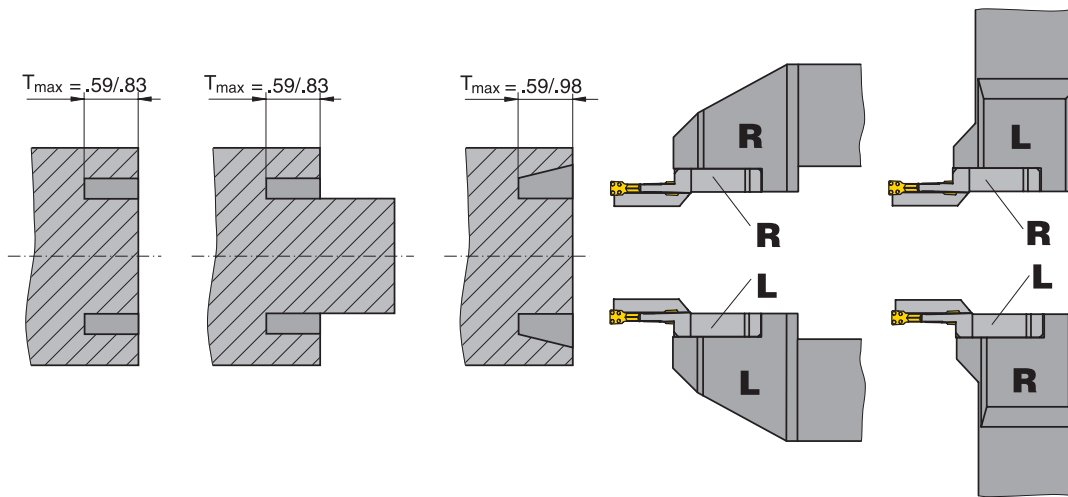

## machining possibilities with long axial module only

Depending on the diameter range or width class an axial displacement (dimension "x") might be necessary when producing the second groove. The "x" dimension depends on the groove diameter and shank height.

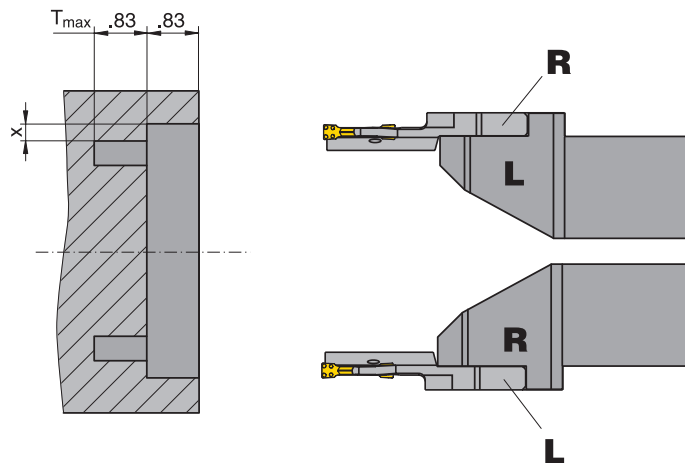

gen.inf.



page E2-E7

-FX

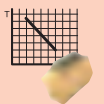

page E8-E13

-GX / -LX



page E14-E24

-LX

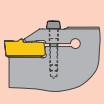

page E25

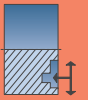

page E26-E29

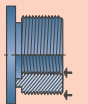

page E30-E39

Special shapes



page E40-E41

Assembly dimensions

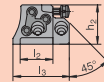

page E42-E43

# Machining guidance

Application  
possibilities

page E26-E27

Machining  
guidance

page E28-E29

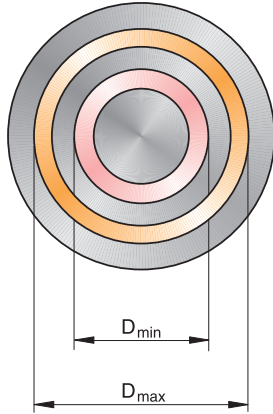

diameter range ( $D_{min}$ - $D_{max}$ )
1.97 - 2.75 inch
2.75 - 3.94 inch
3.94 - 5.90 inch
5.90 - 11.81 inch
11.81 - 35.43 inch

**Important:** The indicated diameters refer to the external groove diameter.

diameter range	MSS assembly size								
	20	25				32			
	grooving width	grooving width						grooving width	
		short module		long module					
	.1087 - .1476	.1087 - .1476	.1480 - .197	.1972 - .256	.1480 - .197	.1972 - .256	.1480 - .197	.1972 - .256	
1.97 - 2.75	●	●	●	●	●	●	●	●	
2.75 - 3.94	●	●	●	●	●	●	●	●	
3.94 - 5.90	●	●	●	●	●	●	●	●	
5.90 - 11.81			●	●	●	●	●	●	
11.81 - 35.43								●	
maximum grooving depth	.551	.590		.827		.590			



**Attention:** The diameter of face grooves must lie within the diameter range indicated on the module. Otherwise the tool can be damaged or destroyed.

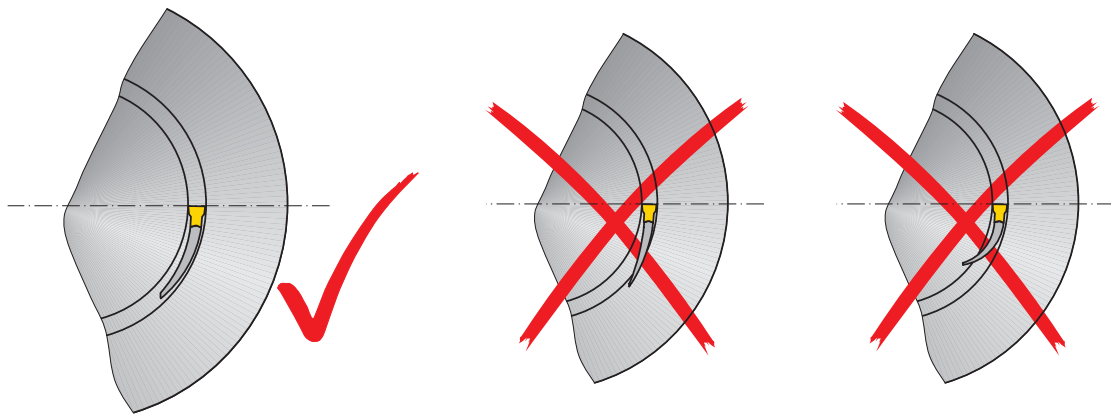

correct axial grooving module

incorrect axial grooving module

# Machining guidance

## application guidance for axial grooving and face turning

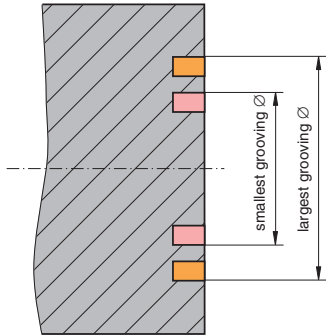

### Axial grooving

Is only possible with modules within the fixed diameter range (e.g. 1.97 - 2.75 inch).

**Important:** The indicated diameter range is always valid for the external diameter of the groove!

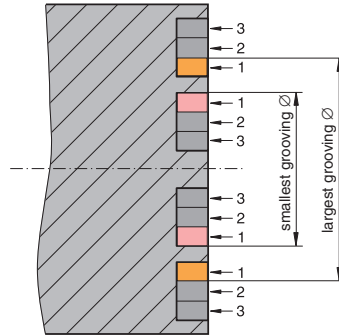

### Axial grooving - groove widening

Groove widening is possible above and below the diameter range indicated on the module.

**Important:** Only the first groove must lie within the diameter range of the module. The depth of the widening groove must not be larger than the depth of the original groove.

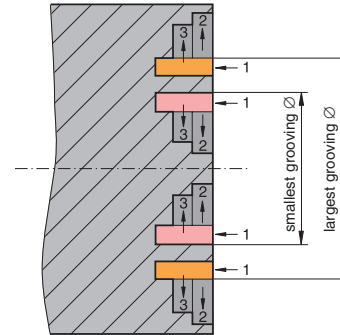

### Axial grooving and face turning

In case of face turning it is possible to widen the the groove above and below the diameter range indicated on the module.

**Important:** Only the first groove must lie within the diameter range of the module.

## axial grooving and face turning

designation		
	f [ipr]	$a_{max}$ [inch]      f [ipr]
GX24-2E3.00N0.30	.0020 - .0059	.098      .0020 - .0079
GX24-3E4.00N0.40	.0020 - .0059	.118      .0020 - .0100
GX24-3E5.00N0.40	.0020 - .0059	.118      .0039 - .0100
GX24-4E6.00N0.50	.0020 - .0079	.138      .0039 - .0120
GX24-2E3.00N0.30-F2	.0010 - .0050	.098      .0020 - .0059
GX24-2E3.50N0.30-F2	.0010 - .0050	.098      .0020 - .0059
GX24-3E4.00N0.40-F2	.0020 - .0059	.118      .0039 - .0079
GX24-3E4.50N0.40-F2	.0020 - .0059	.118      .0039 - .0079
GX24-3E5.00N0.40-F2	.0030 - .0079	.138      .0039 - .0079
GX24-4E6.00N0.50-F2	.0039 - .0100	.157      .0039 - .0100

gen.inf.



page E2-E7

-FX

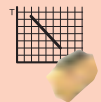

page E8-E13

-GX / -LX



page E14-E24

-LX

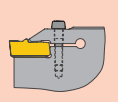

page E25

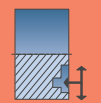

pag. E26-E29

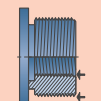

page E30-E39

Special shapes

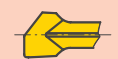

page E40-E41

Assembly dimensions

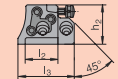

page E42-E43

# TC threads

## Basics for threading

Basics

page E30

Thread  
problems

page E31

Recommended  
values

page E32-E33

Machining  
method

page E34-E35

TC  
thread  
milling

page E36-E37

Cutting  
data

page E38

Grades

page E39

### differences between full and partial profile inserts

#### full profile insert

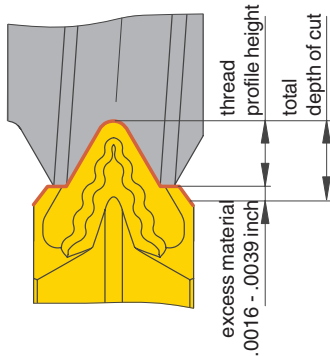

- + the entire thread profile including the external  $\varnothing$  is machined (excess material .0016 - .0039 inch over finished diameter)
- + high profile precision
- + increased tool life due to larger point radii
- + burr-free thread
- one insert per pitch

#### partial profile insert

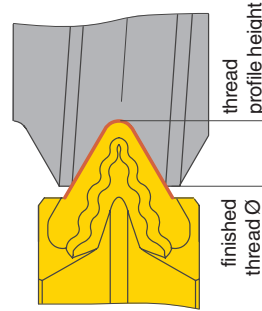

- + one insert for several pitches
- therefore thread profile does not exactly meet standard
- the external  $\varnothing$  (or the core  $\varnothing$  in case of internal threads) is not machined

### approach selection

#### radial approach

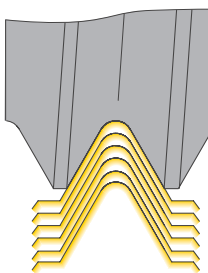

- + conventional turning lathes
- + with pitches > 12 tpi
- + with short chipping materials
- reduced swarf control

#### flank approach

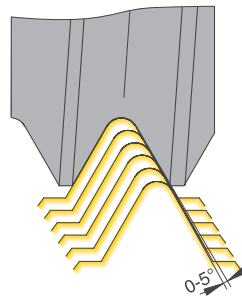

- + preferred approach on CNC-machines
- + with pitches from 6 - 12 tpi
- + long chipping materials
- + good swarf control

#### alternating approach

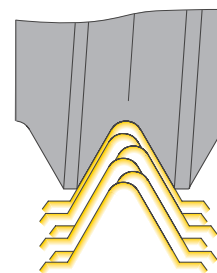

- + with pitches < 6 tpi
- + long chipping materials
- + even insert wear
- + long tool life
- + good swarf control
- difficult NC programming



# Measures in case of thread problems

## MSS TC thread turning

type of problem											measures, remedy				
wear type				work piece				chip control					cutting values	insert selection	misc. criteria
clearance face wear	edge break out	plastic deformation	built up edge	burr formation at external thread Ø	profile precision	surface finish	chatter marks, vibrations	chip cross section too large	chip cross section too small	chip shape (snarl chip)					
↓		↓	↑			↑	↓				cutting speed	cutting values			
a,b	a,b		a,b	a,b		a,b	a,b	a,b		a,b	feed motion a) via the flanks b) alternating via the flanks				
↑	↓	↓		↓	↓	↓	↓	↓	↑	~	feed motion (cutting depth)	cutting values			
↓	↑	↑		~	~	↑	~	↑	↓	↓	number of passes				
				●	●	●					finish cut (idle cut)	insert selection			
			●			●	●			●	chipgroove				
↑	↓	↑									cutting material ↓ wear resistance toughness ↑	insert selection			
				●	●	●					full profile				
											partial profile	misc. criteria			
	~					~	~				tool / insert stability				
	~					~	~				work piece stability				
	↓					↓	↓				overhang				
~	~	~				~	~				top height				
●	●	●	●	●		●					cooling lubricant				

↑ raise, increase large influence  
↑ raise, increase low influence

↓ avoid, reduce large influence  
↓ avoid, reduce low influence

~ check, optimize  
● use

gen.inf.



page E2-E7

-FX

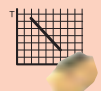

page E8-E13

-GX / -LX



page E14-E24

-LX

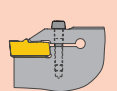

page E25

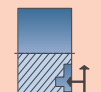

page E26-E29

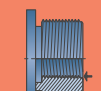

page E30-E39

Special shapes



page E40-E41

Assembly dimensions

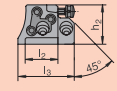

page E42-E43

# TC thread turning

## Recommended values for depth and number of cuts

Basics

page E30

Thread  
problems

page E31

Recommended  
values

page E32-E33

Machining  
method

page E34-E35

TC  
thread  
milling

page E36-E37

Cutting  
data

page E38

Grades

page E39



### Full profile

### Metric ISO 60° external threads

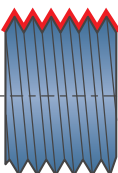

	pitch [mm]		0,5		0,75		1,0		1,25		1,5		1,75		2,0		2,5		3,0		3,5		4,0		4,5		5,0		
	[inch]		.020		.029		.039		.049		.059		.069		.079		.098		.118		.138		.157		.177		.197		
number of cuts			4	4	5	5	6	7	8	9	10	10	12	12	12	12	12	12	12	12	12	12	12	12	12	12	12	12	12
			↓	↓	↓	↓	↓	↓	↓	↓	↓	↓	↓	↓	↓	↓	↓	↓	↓	↓	↓	↓	↓	↓	↓	↓	↓	↓	↓
thread profile height [mm]			0,32	0,48	0,64	0,80	0,95	1,10	1,26	1,58	1,89	2,21	2,53	2,84	3,16														
			[inch]	.012	.019	.025	.031	.037	.043	.050	.062	.074	.087	.100	.112	.124													

these are recommended values for steel machining

### Metric ISO 60° internal threads

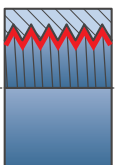

	pitch [mm]		0,5		0,75		1,0		1,25		1,5		1,75		2,0		2,5		3,0		3,5		4,0		4,5		5,0		
	[inch]		.020		.029		.039		.049		.059		.069		.079		.098		.118		.138		.157		.177		.197		
number of cuts			4	4	5	5	6	7	8	9	10	10	12	12	12	12	12	12	12	12	12	12	12	12	12	12	12	12	
			↓	↓	↓	↓	↓	↓	↓	↓	↓	↓	↓	↓	↓	↓	↓	↓	↓	↓	↓	↓	↓	↓	↓	↓	↓	↓	↓
thread profile height [mm]			0,30	0,45	0,59	0,74	0,89	1,02	1,17	1,46	1,76	2,02	2,35	2,64	2,93														
			[inch]	.012	.018	.023	.029	.035	.040	.046	.057	.069	.079	.092	.104	.115													

these are recommended values for steel machining

### Whitworth 55° external and internal thread

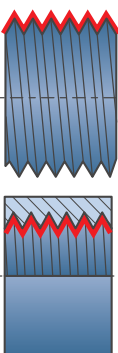

	pitch [passes/inch]		28		26		24		20		19		18		16		14		12		11		10		9		8		7		6		5	
	number of cuts			5	5	5	5	6	6	7	8	9	9	10	10	10	10	10	10	10	10	10	10	10	10	10	10	10	10	10	10	10	10	
		↓	↓	↓	↓	↓	↓	↓	↓	↓	↓	↓	↓	↓	↓	↓	↓	↓	↓	↓	↓	↓	↓	↓	↓	↓	↓	↓	↓	↓	↓	↓		
thread profile height [mm]			0,60	0,65	0,70	0,84	0,88	0,93	1,05	1,20	1,40	1,53	1,68	1,87	2,11	2,41	2,81	3,37																
			[inch]	.024	.025	.027	.033	.035	.037	.041	.047	.055	.060	.066	.074	.083	.095	.111	.133															

these are recommended values for steel machining



# Partial profile



## 60° external and internal threads

thread insert	TC16-2EI-AG60												TC16-3EI-N60					
	TC16-1EI-A60						TC16-2EI-G60						TC16-3EI-N60					
pitch [mm]	0,5	0,75	1,0	1,25	1,5	1,75	2,0	2,5	3,0	1,75	2,0	2,5	3,0	3,5	4,0	4,5	5,0	
	[inch]	.020	.029	.039	.049	.059	.069	.079	.098	.118	.069	.079	.098	.118	.138	.157	.177	
number of cuts	4	4	5	6	7	8	9	10	12	8	9	10	12	12	13	14	14	
	↓	↓	↓	↓	↓	↓	↓	↓	↓	↓	↓	↓	↓	↓	↓	↓	↓	
thread profile height [mm]	0,33	0,52	0,71	0,90	1,09	1,28	1,47	1,84	2,22	1,23	1,42	1,79	2,17	2,45	2,83	3,21	3,59	
external [inch]	.013	.020	.028	.035	.043	.050	.058	.072	.087	.048	.056	.070	.085	.096	.111	.126	.141	
thread profile height [mm]	0,27	0,44	0,60	0,76	0,92	1,09	1,25	1,57	1,90	1,04	1,20	1,52	1,85	2,07	2,40	2,72	3,05	
internal [inch]	.011	.017	.024	.030	.036	.043	.049	.062	.075	.041	.047	.060	.073	.081	.094	.107	.120	

these are recommended values for steel machining

## 55° external and internal threads

thread insert	TC16-2EI-AG55													
	TC16-1EI-A55													
pitch [passes/inch]	28	26	24	20	19	18	16	14	12	11	10	9	8	
number of cuts	5	5	6	6	7	7	8	9	10	10	11	12	12	
thread profile height [mm]	0,66	0,72	0,79	0,95	1,01	1,07	1,21	1,39	1,63	1,79	1,97	2,20	2,48	
height [inch]	.026	.028	.031	.037	.040	.042	.048	.055	.064	.070	.077	.087	.098	

thread insert	TC16-2EI-G55						TC16-3EI-N55			
	pitch [passes/inch]	14	12	11	10	9	8	7	6	5
number of cuts	8	9	10	11	12	12	12	12	14	
thread profile height [mm]	1,22	1,46	1,56	1,80	2,03	2,31	2,40	2,89	3,56	
height [inch]	.048	.057	.061	.071	.080	.091	.094	.114	.140	

these are recommended values for steel machining

gen.inf.



page E2-E7

-FX

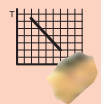

page E8-E13

-GX / -LX



page E14-E24

-LX

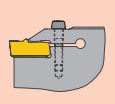

page E25

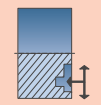

page E26-E29

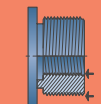

page E30-E39

Special shapes



page E40-E41

Assembly dimensions

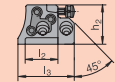

page E42-E43

# MSS - TC

## Machining method thread turning

Basics

page E30

Thread  
problems

page E31

Recommended  
values

page E32-E33

Machining  
method

page E34-E35

TC  
thread  
milling

page E36-E37

Cutting  
data

page E38

Grades

page E39

### application methods for external machining

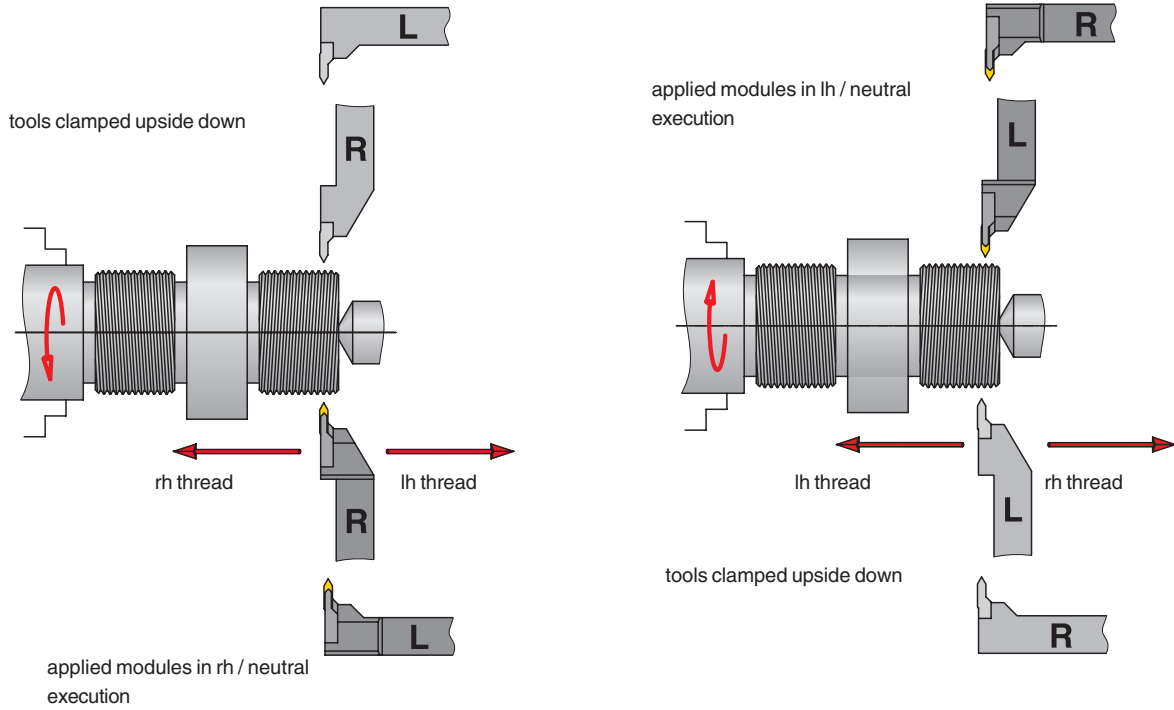

### application methods for internal machining

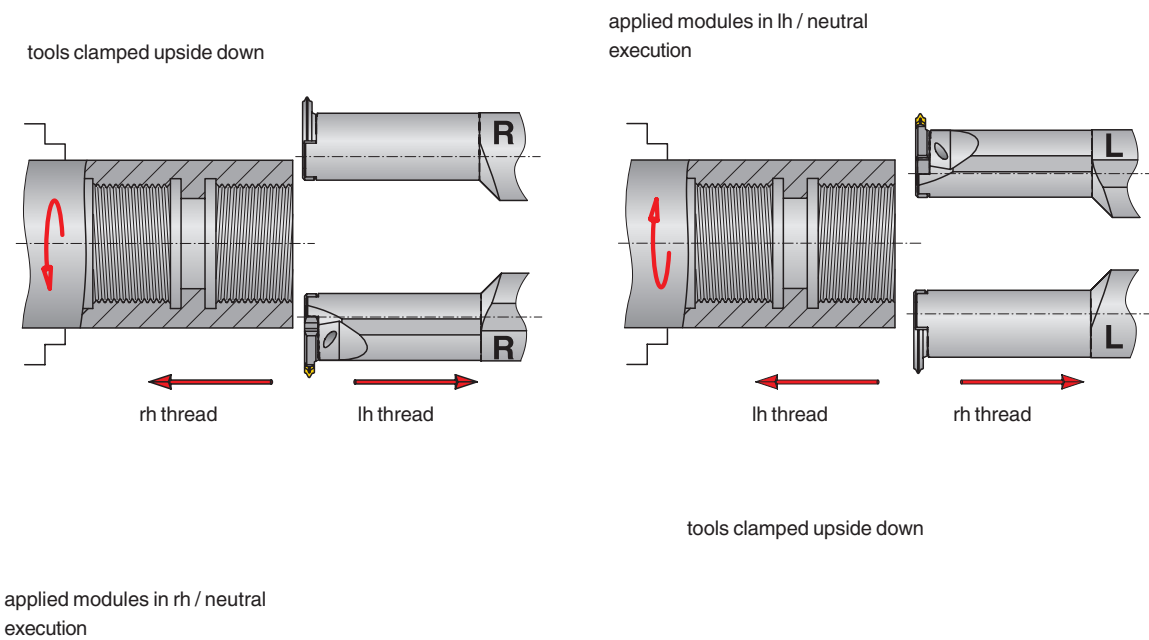

# MSS - TC

## Machining method thread turning

Technical information

### external threads

	conventional milling	climb milling
right hand thread		
left hand thread		

### internal threads

	conventional milling	climb milling
right hand thread		
left hand thread		

gen.inf.



page E2-E7

-FX

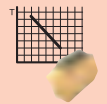

page E8-E13

-GX / -LX



page E14-E24

-LX

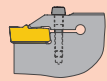

page E25

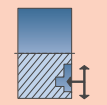

page E26-E29

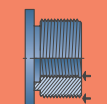

page E30-E39

Special shapes



page E40-E41

Assembly dimensions

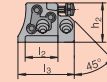

page E42-E43

# TC thread milling

## 3 steps of threading

Basics

page E30

Thread  
problems

page E31

Recommended  
values

page E32-E33

Machining  
method

page E34-E35

TC  
thread  
milling

page E36-E37

Cutting  
data

page E38

Grades

page E39

### 1. drilling

through hole thread

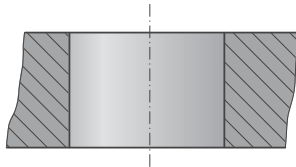

bottom hole thread

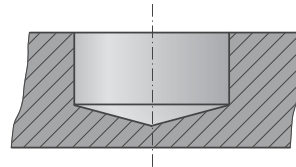

### 2. chamfering

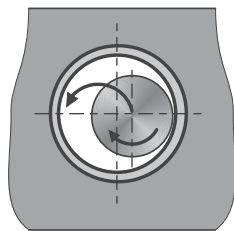
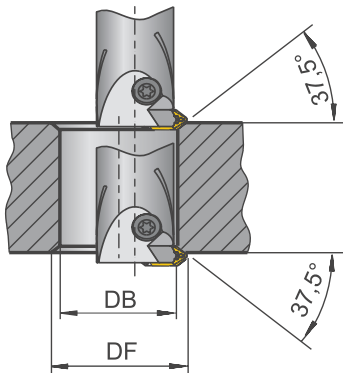
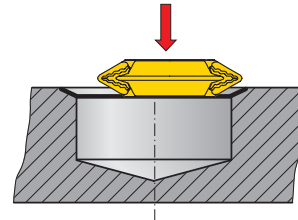
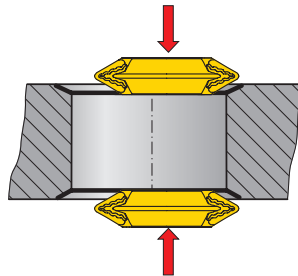

DB = thread drilling  $\varnothing$   
DF = chamfer  $\varnothing$

#### TC thread milling cutters also for chamfering

- ⇒ use standard TC milling cutters + TC chamfering insert
- ⇒ applicable for front and back chamfer
- ⇒ very good component access
- ⇒ for drilling depths of 2xD (3xD)

tool	insert	DB <sub>min</sub>	DF
I25R90-2D-TC16-W	TC16-3-75	1.063	DF = thread nominal $\varnothing$ +.020 - .059 inch
I32R90-2D-TC16-W		1.338	
MSS-I32R90-1,5D +Modul MSS-I32N-TC16-3		1.968	
MSS-I32R90-2,5D +Modul MSS-I32N-TC16-3		3.150	



### 3. threading

#### through hole thread

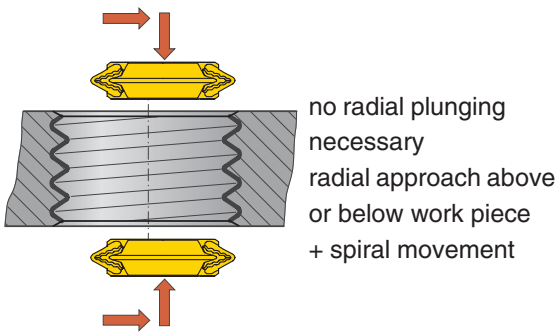

#### bottom hole thread

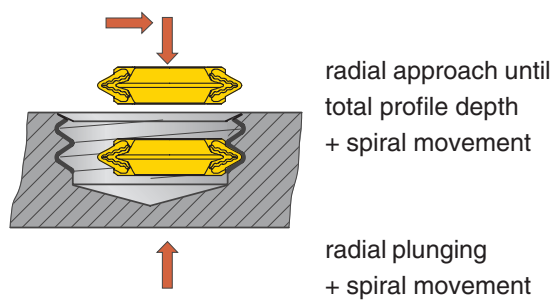

### advantages compared to multi-tooth threading insert

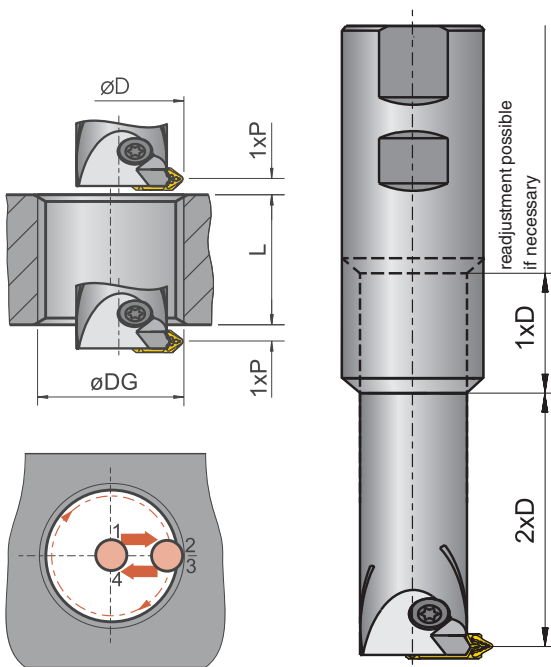

I25R90-2D-TC16-W  
I32R90-2D-TC16-W

- ⇒ same insert for thread turning and milling
- ⇒ considerably lower costs of TC insert
- ⇒ thread is cut continuously from outside towards inside or vice versa, therefore no interruption (step) in thread
- ⇒ low cutting forces through single-tooth thread milling create stable conditions
- ⇒ larger overhang possible
- ⇒ standard =  $2 \times D$  – readjustment up to  $3 \times D$  possible
- ⇒ higher cutting values ( $v_c + f$ )
- ⇒ in this manner machining times are similar to multi-tooth insert machining
- ⇒ easy programming

gen.inf.



page E2-E7

-FX

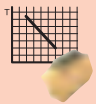

page E8-E13

-GX / -LX

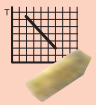

page E14-E24

-LX

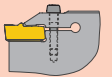

page E25

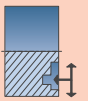

page E26-E29

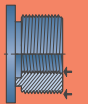

page E30-E39

Special shapes



page E40-E41

Assembly dimensions

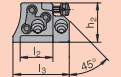

page E42-E43

# Cutting data values

				hardness	GM213	GM240	H216T	
work piece material		type of treatment / alloy		HB	v <sub>c</sub> [sfpm]	v <sub>c</sub> [sfpm]	v <sub>c</sub> [sfpm]	
A	non alloyed steel	annealed	≤ 0,15% C	125	495 - 820	394 - 590	—	
		annealed	0,15% - 0,45% C	150-250	361 - 590	295 - 492	—	
		tempered	≥ 0,45% C	300	295 - 525	230 - 394	—	
	low alloy steel	annealed		180	328 - 558	246 - 426	—	
		tempered		250-300	262 - 492	230 - 361	—	
		tempered		350	230 - 394	230 - 259	—	
	high alloy steel	annealed		200	295 - 426	213 - 279	—	
		tempered		350	230 - 361	197 - 262	—	
	corrosion resistant steel	annealed	ferritic	200	361 - 558	328 - 492	—	
		tempered	martensitic	325	295 - 459	262 - 394	—	
	R	stainless steel	annealed	ferritic / martensitic	200	361 - 590	328 - 492	—
			quenched	austenitic	180	262 - 459	230 - 361	—
quenched			duplex	230-260	230 - 328	180 - 279	—	
hardened			martensitic / austenitic	330	230 - 394	197 - 295	—	
F	grey cast iron		perlitic / ferritic	180	394 - 525	—	—	
			perlitic / martensitic	260	328 - 426	—	—	
	SG iron / spheroidal graphite		ferritic	160	525 - 656	—	—	
			perlitic	250	295 - 459	—	—	
	tempered cast iron		ferritic	130	394 - 459	—	—	
			perlitic	230	295 - 426	—	—	
N	malleable aluminum alloys	not hardenable		60	—	—	328 - 3040	
		hardenable		100	—	—	328 - 3040	
	cast aluminum alloys	not hardenable	< 12% Si	80	—	—	328 - 1640	
		hardenable	< 12% Si	90	—	—	328 - 1640	
	not hardenable	> 12% Si	130	—	—	328 - 1148		
S	copper and copper alloys (bronze, brass)		machining alloy stock (1% Pb)		—	—	240 - 984	
			brass, red bronze	90	—	—	240 - 1640	
			bronze	100	—	—	240 - 1640	
			lead-free copper and electrolytic copper	100	—	—	240 - 1640	
non metal materials		thermosetting plastics		—	—	240 - 1640		
		fibre-reinforced plastics		—	—	240 - 1640		
		hard rubber		—	—	240 - 1640		
H	heat resistant alloys	annealed	Fe-base	200	98 - 164	65 - 131	—	
		hardened	Fe-base	280	82 - 115	65 - 98	—	
		annealed	Ni- or Co-base	250	49 - 82	33 - 65	—	
		hardened	Ni- or Co-base	350	33 - 66	33 - 65	—	
		cast	Ni- or Co-base	320	33 - 82	33 - 65	—	
	titanium alloys		pure titanium	R <sub>m</sub> 400*	328 - 492	230 - 328	—	
		alpha + beta alloys	R <sub>m</sub> 1050*	131 - 197	82 - 148	—		
H	hardened steel	hardened and tempered		55 HRC	115 - 148	—	98 - 131	
		hardened and tempered		60 HRC	—	—	—	
	hard castings	cast		400	33 - 66	—	16 - 49	
hardened cast irons	hardened and tempered		55 HRC	115 - 148	—	98 - 131		

\* R<sub>m</sub> = maximum tensile strength, measured in Mpa

# Grade overview TC threads

material group acc. to VDI 3323	application range cutting mat. acc. to ISO	cutting material / grade			
		coated	uncoated		
A	Steel	P	10	GM213	
			20		GM240
			30		
			40		
			50		
R	Stainless	M	10	GM213	
			20		GM240
			30		
			40		
F	Cast iron	K	01		
			10	GM213	
			20		
N	Non ferrous metals	K	01		
			10		H216T
			20		
S	Heat resistant	M/K	10		
			20		GM240
			30		
			40		
H	Hard materials	K	01	GM213	
			10		H216T
			20		
			30		

gen.inf.



page E2-E7

-FX

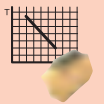

page E8-E13

-GX / -LX

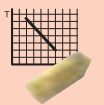

page E14-E24

-LX

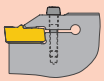

page E25

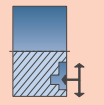

page E26-E29

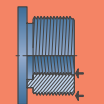

page E30-E39

Special shapes



page E40-E41

Assembly dimensions

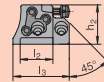

page E42-E43

# GX special shapes

GX special shapes

GX indexable inserts are available in special shapes upon request. In the following overview you will find the most important ones. The indicated dimensions show the details which are necessary for ordering the special shapes.

**Important:** indicate dimensions and tolerances of work piece!

page E40-E41

Assembly dimensions

page E42-E43

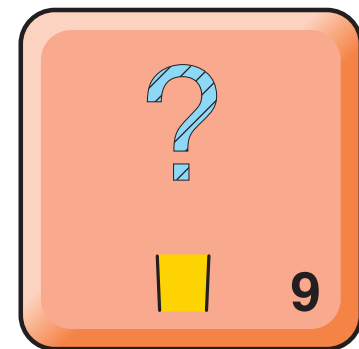
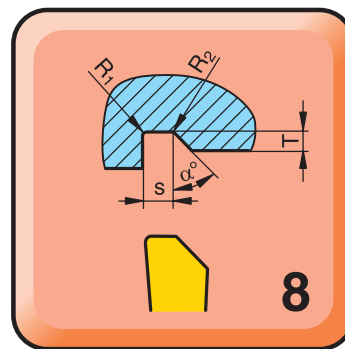
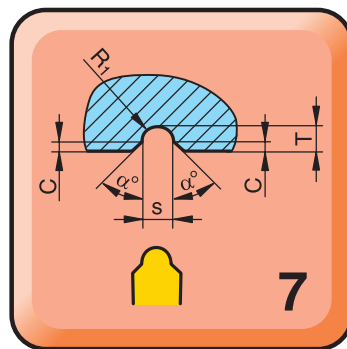
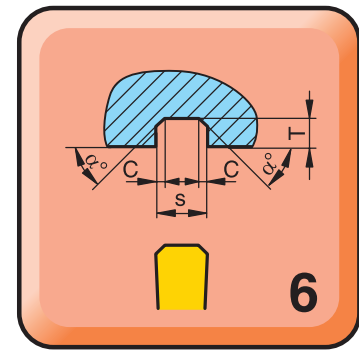
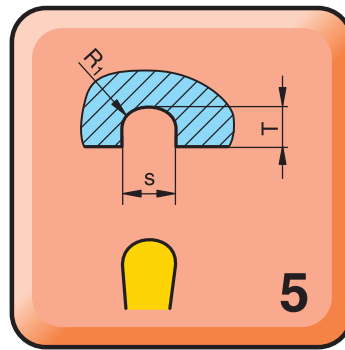
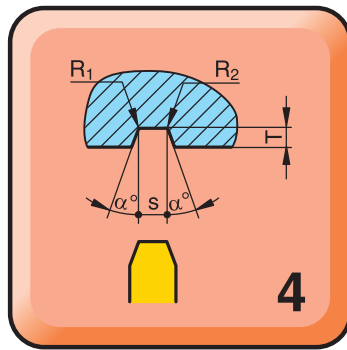
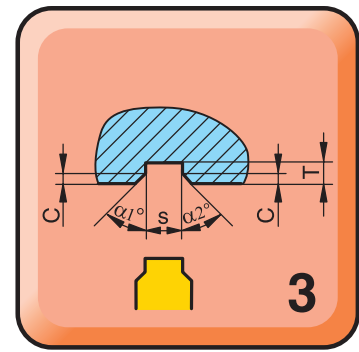
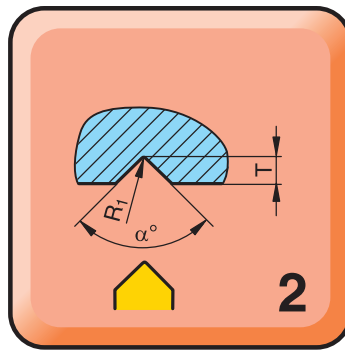
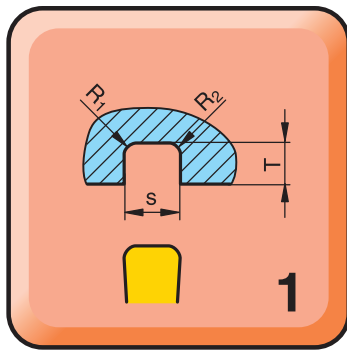

For inquiries kindly use the form on the next page indicating the respective special shape number and the requested main dimensions.

# GX special shapes

Technical information

## inquiry form for special shapes

base insert for special shapes			
width class	insert size	s	a <sub>max</sub>
1	09	.079 - .108	.059
2		.109 - .148	.079
1	16	.079 - .108	.098
2		.109 - .148	.118
3		.148 - .197	.138
4		.197 - .256	.157
2	24	.109 - .148	.098
3		.148 - .197	.138
4		.197 - .256	.157

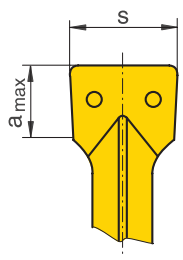

quantity: ..... pcs.

insert size:  09  16  24

width class: 

1	2	3	4

special profile no. ....

s	.....	inch
C	.....	inch
T	.....	inch
R <sub>1</sub>	.....	inch
R <sub>2</sub>	.....	inch
α <sub>1</sub>	.....	°
α <sub>2</sub>	.....	°

internal machining - drilling Ø ..... inch

Please tick the requested fields.

In order to be able to select the optimum chipgroove and hard metal quality we would like to ask you to indicate the working material as well as its tensile strength.

material: .....

tensile strength: .....

gen.inf.  
  
page E2-E7

-FX  
  
page E8-E13

-GX / -LX  
  
page E14-E24

-LX  
  
page E25

page E26-E29

page E30-E39

Special shapes  
  
page E40-E41

Assembly dimensions  
  
page E42-E43

# Application possibilities

GX  
special  
shapes

page E40-E41

Assembly  
sizes

page E42-E43

## application possibilities for MSS adapters:

MSS adapters offer the possibility to apply the modular parting and grooving system where conventional tool shanks or Maxiflex UTS tool heads can not be used.

E.g in case of

- ⇒ special solutions of all kinds
- ⇒ special tools and shanks
- ⇒ rotating tools for circular milling
- ⇒ special machines
- ⇒ limited space

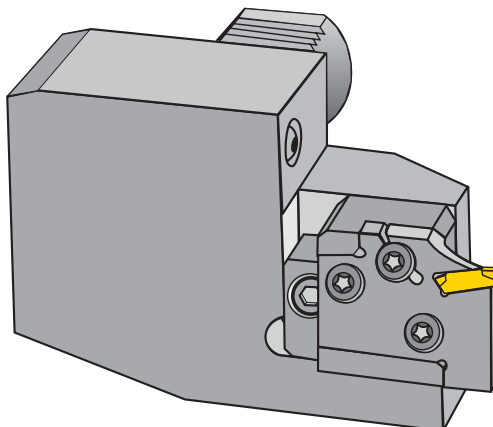
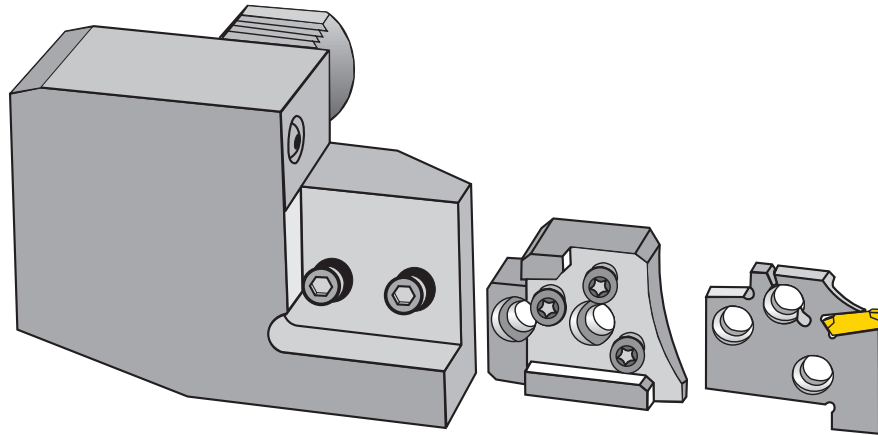

### Assembly example:

adapter in combination with VDI shank



# Assembly dimensions for MSS adapter

## assembly variation A:

- ⇒ for low or medium loads
- ⇒ adjustable adapter

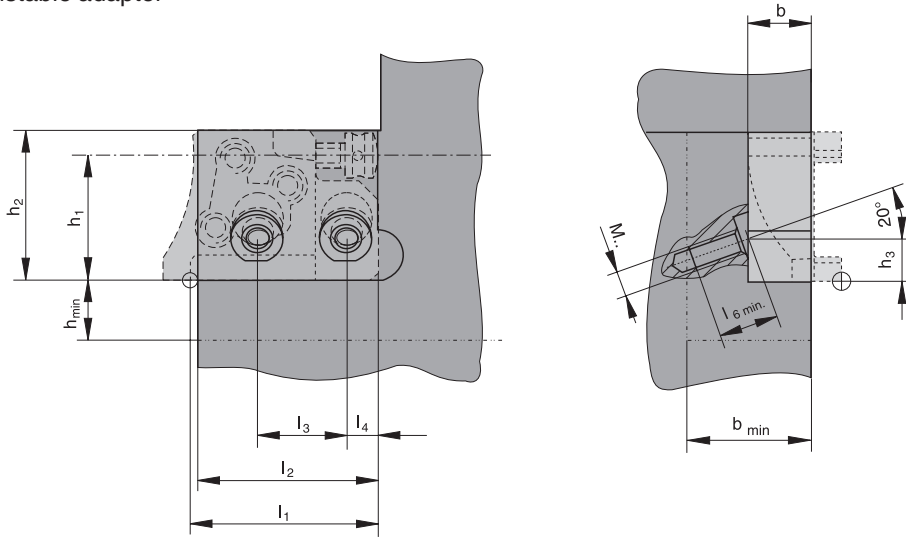

## assembly variation B:

- ⇒ for heavy machining (large parting and grooving depths)
- ⇒ adapter not adjustable

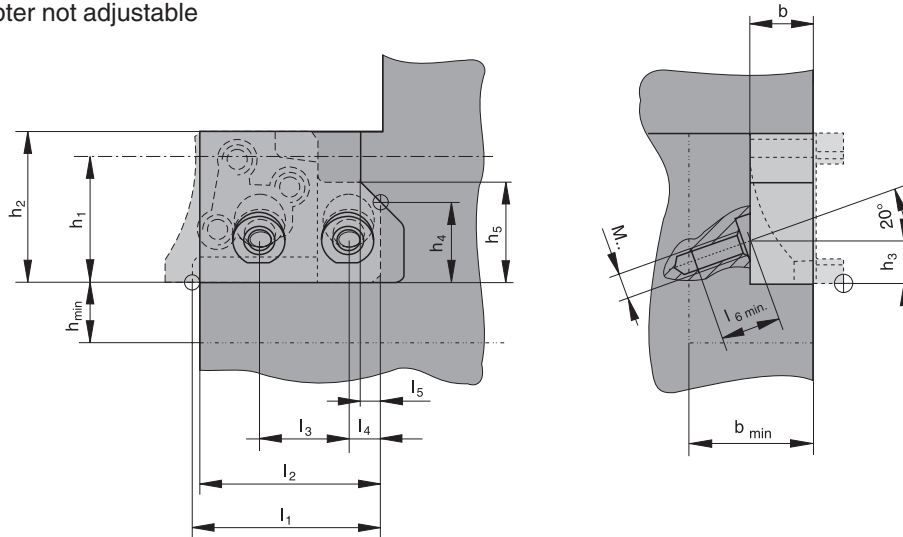

Shank for:	Dimensions in inch														
	h <sub>1</sub>	h <sub>2</sub>	h <sub>3</sub> <sup>±.004</sup>	h <sub>4</sub>	h <sub>5</sub>	h <sub>min.</sub>	b	b <sub>min.</sub>	l <sub>1</sub>	l <sub>2</sub>	l <sub>3</sub>	l <sub>4</sub>	l <sub>5</sub>	l <sub>6min.</sub>	M..*
MSS-E20R00-AD	.787	.945	.236	.512	.630	.394	.421	.748	1.18	1.14	.561	.197	.118	.315	M4
MSS-E20L00-AD															
MSS-E25R00-AD	.984	1.181	.335	.630	.787	.472	.496	.984	1.46	1.42	.709	.256	.157	.472	M5
MSS-E25L00-AD															
MSS-E32R00-AD	1.260	1.496	.531	.867	1.024	.630	.575	1.181	1.81	1.75	.925	.295	.157	.590	M6
MSS-E32L00-AD															

\* ISO metric thread

gen.inf.



page E2-E7

-FX

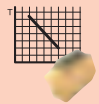

page E8-E13

-GX / -LX



page E14-E24

-LX

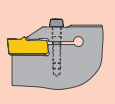

page E25

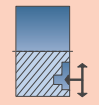

page E26-E29

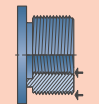

page E30-E39

Special shapes

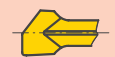

page E40-E41

Assembly dimensions

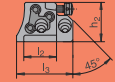

page E42-E43

**Parent company**

PLANSEE TIZIT Aktiengesellschaft  
A-6600 Reutte/Tirol  
Tel.: +43 (5672) 600-0  
Fax: +43 (5672) 600-502 *Cutting Tools*  
+43 (5672) 600-503 *Wear Parts*  
E-Mail: tool.at@plansee.at *Cutting Tools*  
E-Mail: wear.at@plansee.at *Wear Parts*  
<http://www.plansee.com>

**Austria**

PLANSEE TIZIT Aktiengesellschaft  
A-6600 Reutte/Tirol  
Tel.: +43 (5672) 600-0  
Fax: +43 (5672) 600-505  
E-Mail: zerspanung.at@plansee.at  
= *Sales Cutting Tools*

**Bulgaria**

INSTRUMENT AG  
Boulevard Stoletov 157  
BG-5301 Gabrovo  
Tel.: +359 (66) 438-11  
Fax: +359 (66) 437-42  
E-Mail: instrument@eda.bg  
= *Sales Cutting Tools*

**Germany**

PLANSEE TIZIT GmbH  
Schützenstraße 29  
D-72574 Bad Urach  
Tel.: +49 (7125) 1501-0  
Fax: +49 (7125) 8594  
E-Mail: tool.de@plansee.de  
= *Sales Cutting Tools*

**France**

Société PLANSEE TIZIT S.A.R.L.  
20, Rue Lavoisier  
F-95300 Pontoise  
Tel.: +33 (1) 3433-3180  
Fax: +33 (1) 3030-9339  
E-Mail: tool.f@plansee.at  
= *Sales Cutting Tools*

**Great Britain**

PLANSEE TIZIT (UK) Ltd.  
Cliff Lane  
Grappenhall  
Warrington WA4 3JX  
Tel.: +44 (1925) 261-161  
Fax: +44 (1925) 267-933  
E-Mail: tool.uk@plansee.at  
= *Sales Cutting Tools*

**China**

PLANSEE TIZIT Hong Kong Ltd.  
Room 1201-1202  
Hollywood Centre  
233 Hollywood Rd., Sheung Wan  
Hong Kong  
Tel.: (+852) 2542-1838  
Fax: (+852) 2854-3777  
E-Mail: tool.hk@plansee-hk.com  
= *Sales Cutting Tools*

**India**

Siel TIZIT Limited  
58, Motilal Gupta Road  
Barisha  
IN-700 008 Calcutta  
Tel.: +91 (33) 447-5435  
Fax: +91 (33) 447-6472  
Telex: 021 8142 ihm in  
E-Mail: positiz@cal.vsnl.net.in  
= *Sales Cutting Tools*

**Italy**

TIZIT S.p.A  
Piazza F. Martelli, 7  
I-20162 Milano  
Tel.: +39 (02) 6441-111  
Fax: +39 (02) 6611-6040  
E-Mail: tool.i@plansee.at  
= *Sales Cutting Tools*

**Spain**

PLANSEE TIZIT  
Vía de las Dos Castillas, 9c  
Portal 2, Bajo B  
E-28224 Pozuelo (Madrid)  
Tel.: +34 (91) 351-0609  
Fax: +34 (91) 351-2813  
E-Mail: tool.e@plansee.at  
= *Sales Cutting Tools*

**USA**

SCHWARZKOPF  
TECHNOLOGIES Corporation  
115 Constitution Boulevard  
Franklin, MA 02038  
Tel.: +1 (508) 553-3800  
Fax: +1 (508) 553-3823  
E-Mail: tool.usa@stc-ma.com  
= *Sales Cutting Tools*



# PLANSEE TIZIT

# 219

219 USA 11.02