



COMPLETE
METALWORKING
SOLUTIONS

(800) 991-4225

www.ahbinc.com

ISO Certified

customerservice@ahbinc.com

Diamond Tools for BRAKE



PCD Cutting Tool for Aluminium Parts

✓ Boring tools

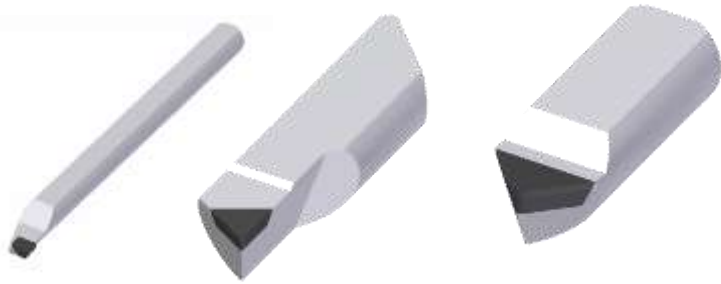

✓ Rotation tools



✓ PCD Inserts

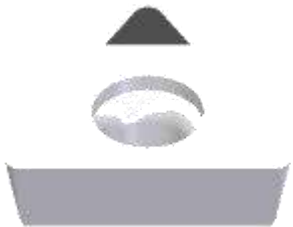

• Brazed Single tip

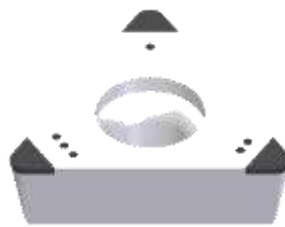

• Brazed Multi corner

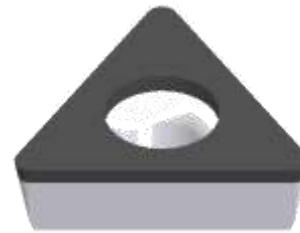

• Full top



• Chip breaker

PCBN Cutting Tool for Cast Iron

✓ PCBN Inserts



• Brazed Single tip



• Brazed Multi corner



• solid



• Full Top



• Sandwich

✓ Boring tools



PCBN SOLID for Brake Disk

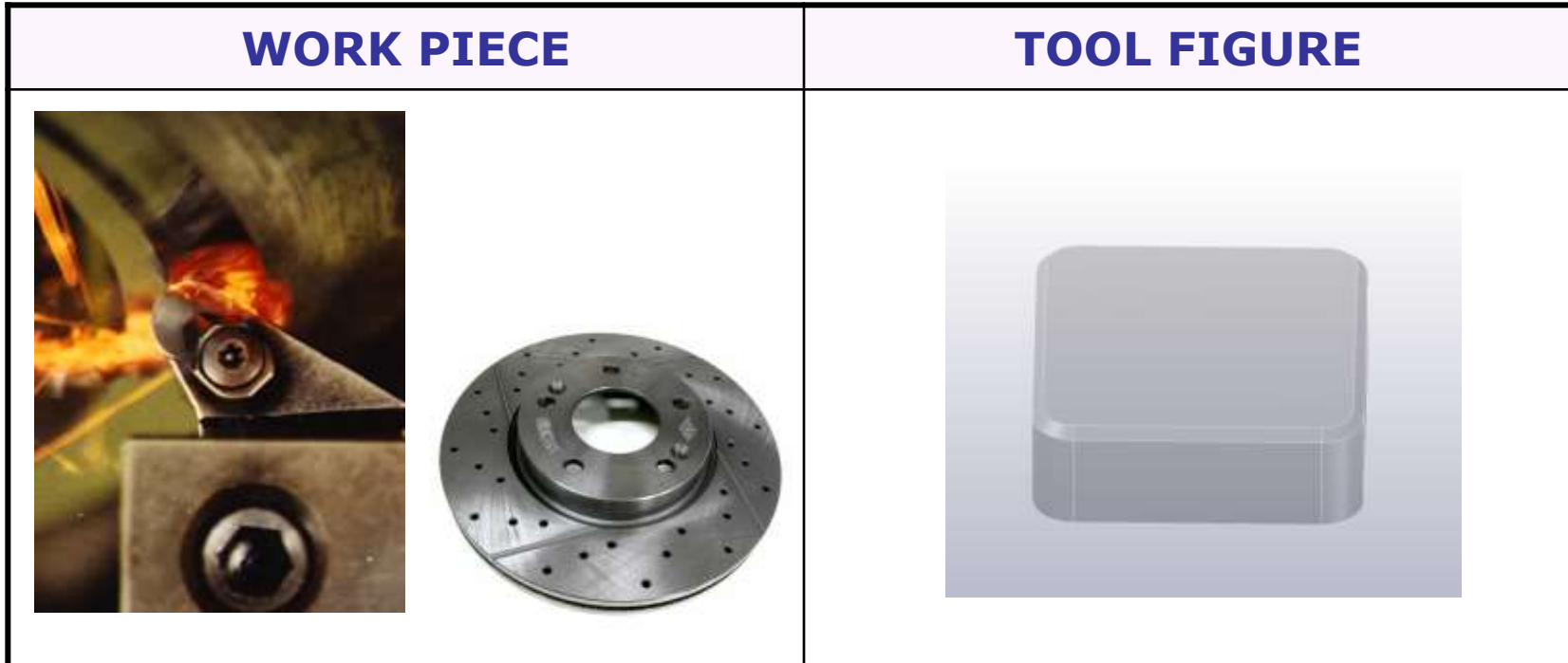

Type of Part	Brake Disc	Feed Rate (mm/rev)	0.35
Work piece Material	FC25	Tool life	680 ea / corner
Spindle speed		Coolant	Dry
Cutting speed(m/min)	1200	Etc	Rough
Depth of cut (mm)	3~4	Tool material	Coated Solid PCBN

PCBN INSERT for Brake Disk

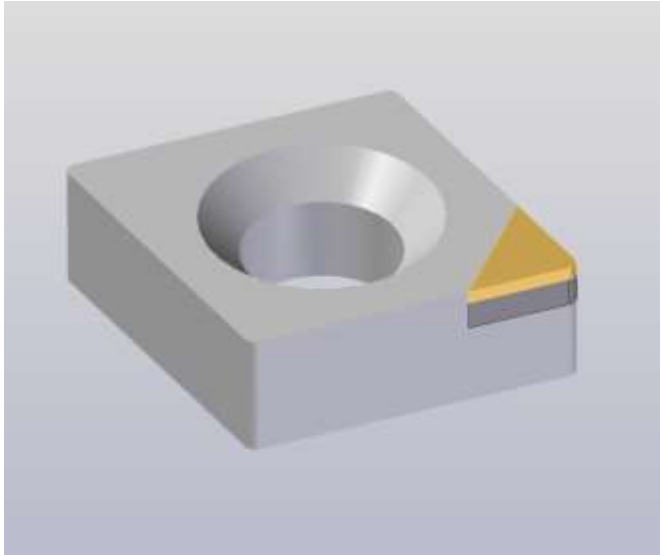
WORK PIECE		TOOL FIGURE	
			
Type of Part	Brake Disc	Feed Rate (mm/min)	0.1
Work piece Material	FC220	Tool life	200 ea / corner
Spindle speed		Coolant	Wet
Cutting speed(m/min)	500	Etc	Finish
Depth of cut (mm)	0.4	Tool material	PCBN

Metal Bond CBN Wheels for Brake Disk

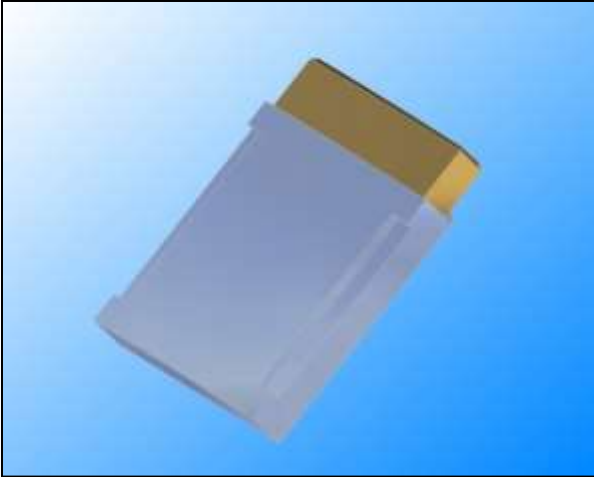

*Segment
Type*

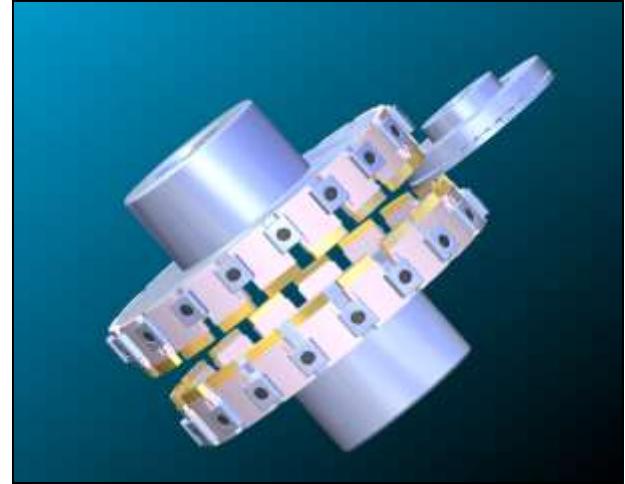

*Continuou
s
Type*



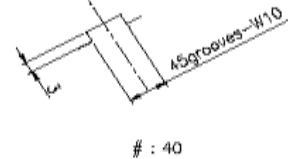
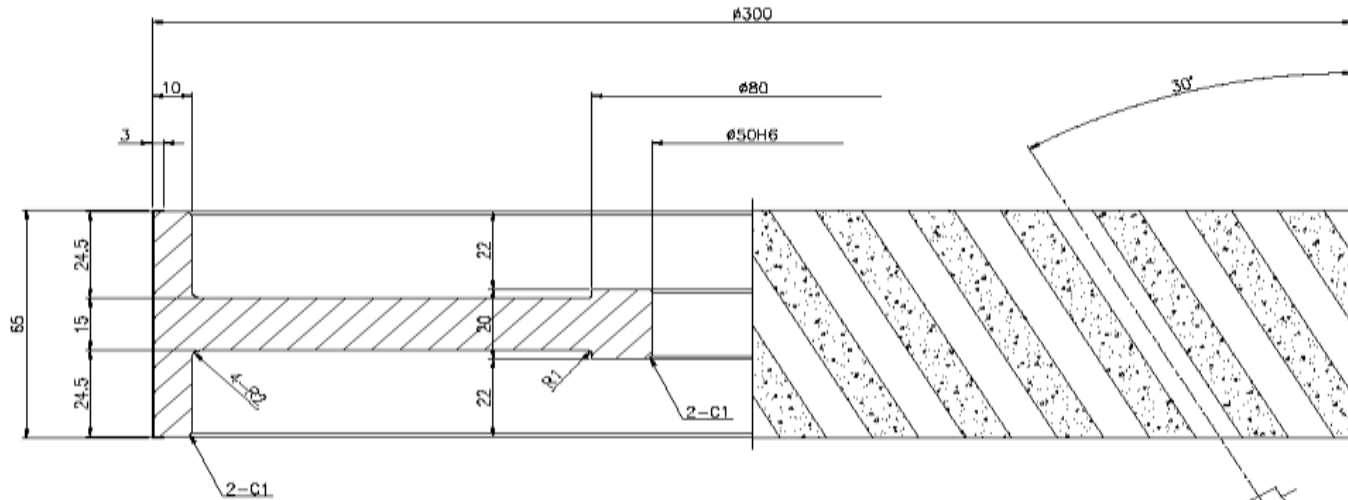

Electroplated Diamond Wheels for Brake Pad

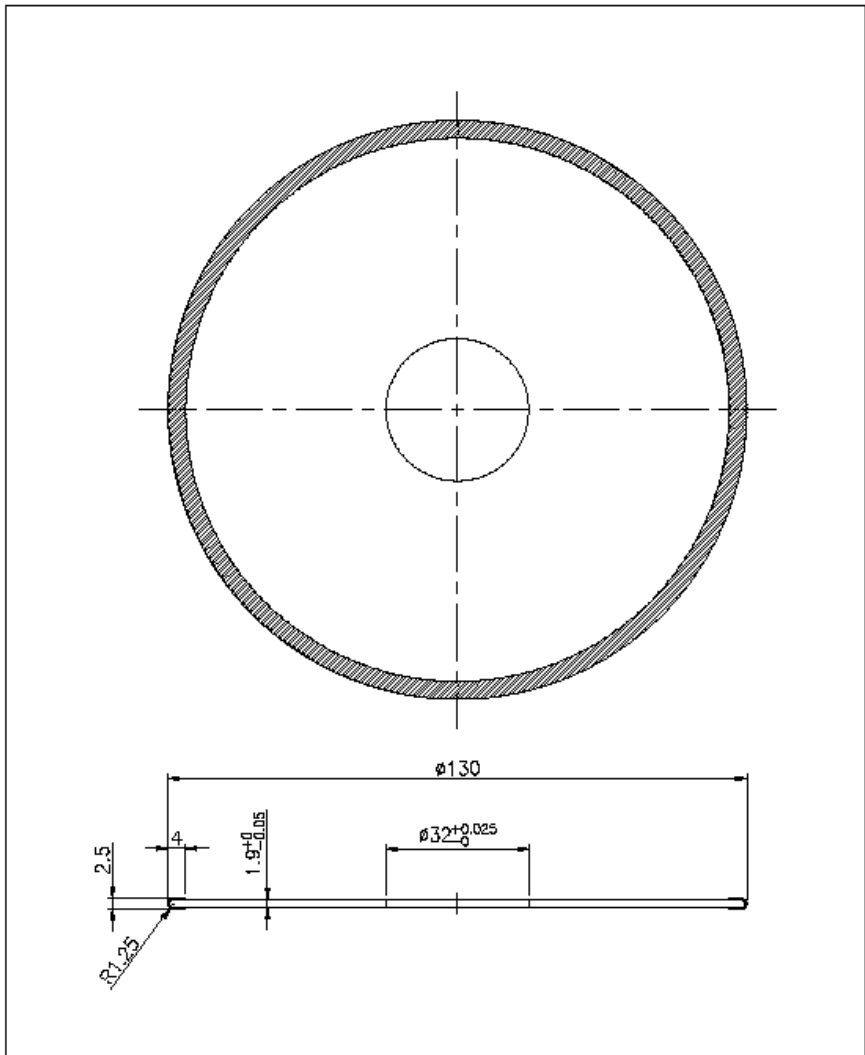
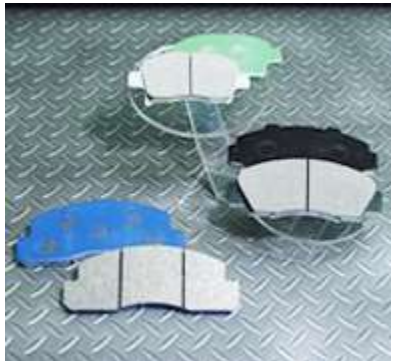

△		CUSTOMER	TAN HOANG VIET TRA	ITEM	ED-1A1		
△		SIZE	300D-65T-3X-5DH,D40	ITEM No			
△		DATE	2008.06.D3	SCALE	1:1	TOLERANCE	
△		DESIGN		CHECKED	APPROVED	MATERIAL	S45C
△						DIM'S	mm
						PRESI	3rd
						DWG No.	ED10360W
REVISIONS						EHWA DIAMOND INDUSTRIAL CO.,LTD.	

Electroplated Diamond Wheels for Brake Pad



△		CUSTOMER	TAN HOANG		ITEM	ED-1FF1		
△		SIZE	J00-2.5T-4X-1.25R-32H,D8					ITEM No.
△		DATE	SCALE	TOLERANCE	MATERIAL	DWG'S	PROJ	DWG No.
△		2008.02.15	1:1		S45C	mm	3rd	E009985W
△		DESIGN	CHECKED	APPROVED				
△		REVISIONS			 EHWA DIAMOND INDUSTRIAL CO.,LTD.			
		EGF-09-02-01(0)						

Electroplated Diamond Wheels for Brake Pad

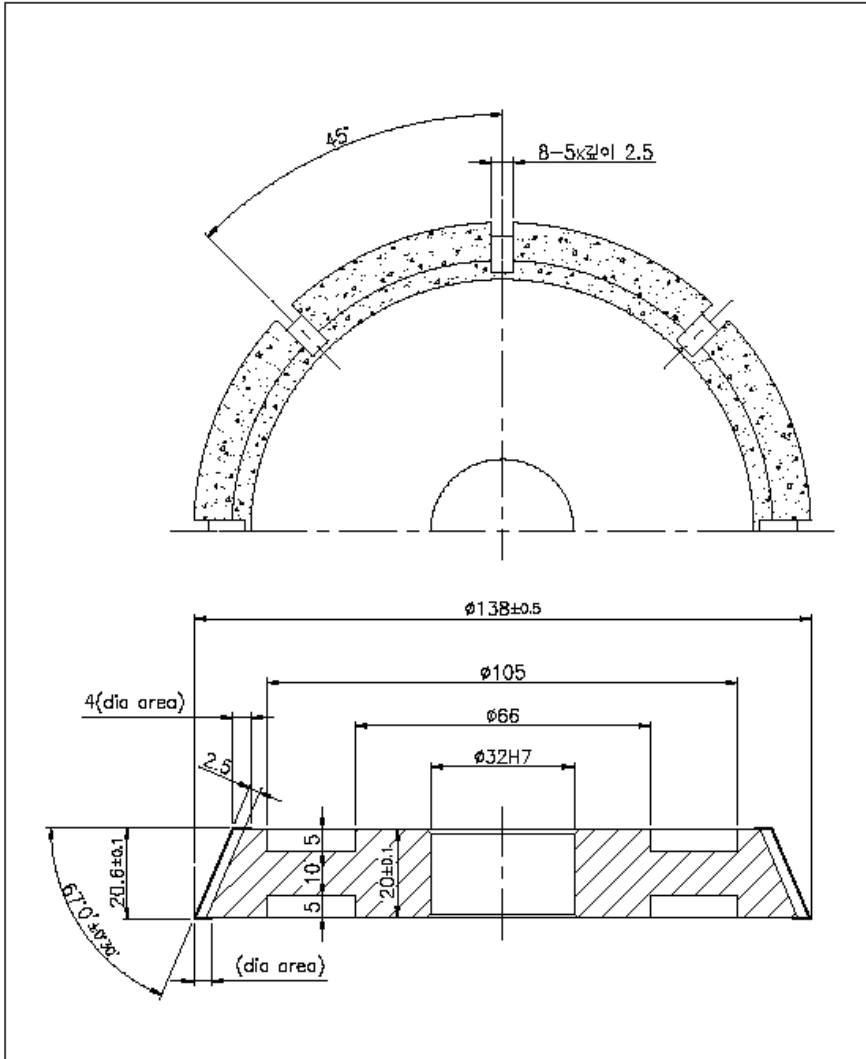
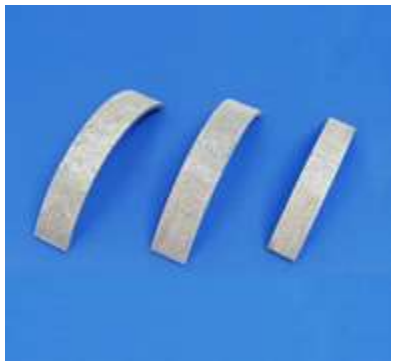
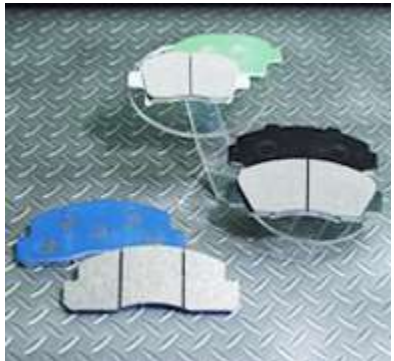

△		CUSTOMER	TAN HOANG VIET TRA		ITEM	ED-1V1	
△		SIZE	138D-2QT-67V-32H.D60		ITEM No.		
△		DATE	SCALE	TOLERANCE	MATERIAL	DM'S	PROJ DWG No.
△		2007.11.01	1:1		S45C	mm	3rd EDD9619W
△		DESIGN	CHECKED	APPROVED			
△	2007.12.21	최종 변경		 EHWA DIAMOND INDUSTRIAL CO.,LTD.			
REVISIONS							

EGF-09-02-01(0)

Electroplated Diamond Wheels for Brake Pad

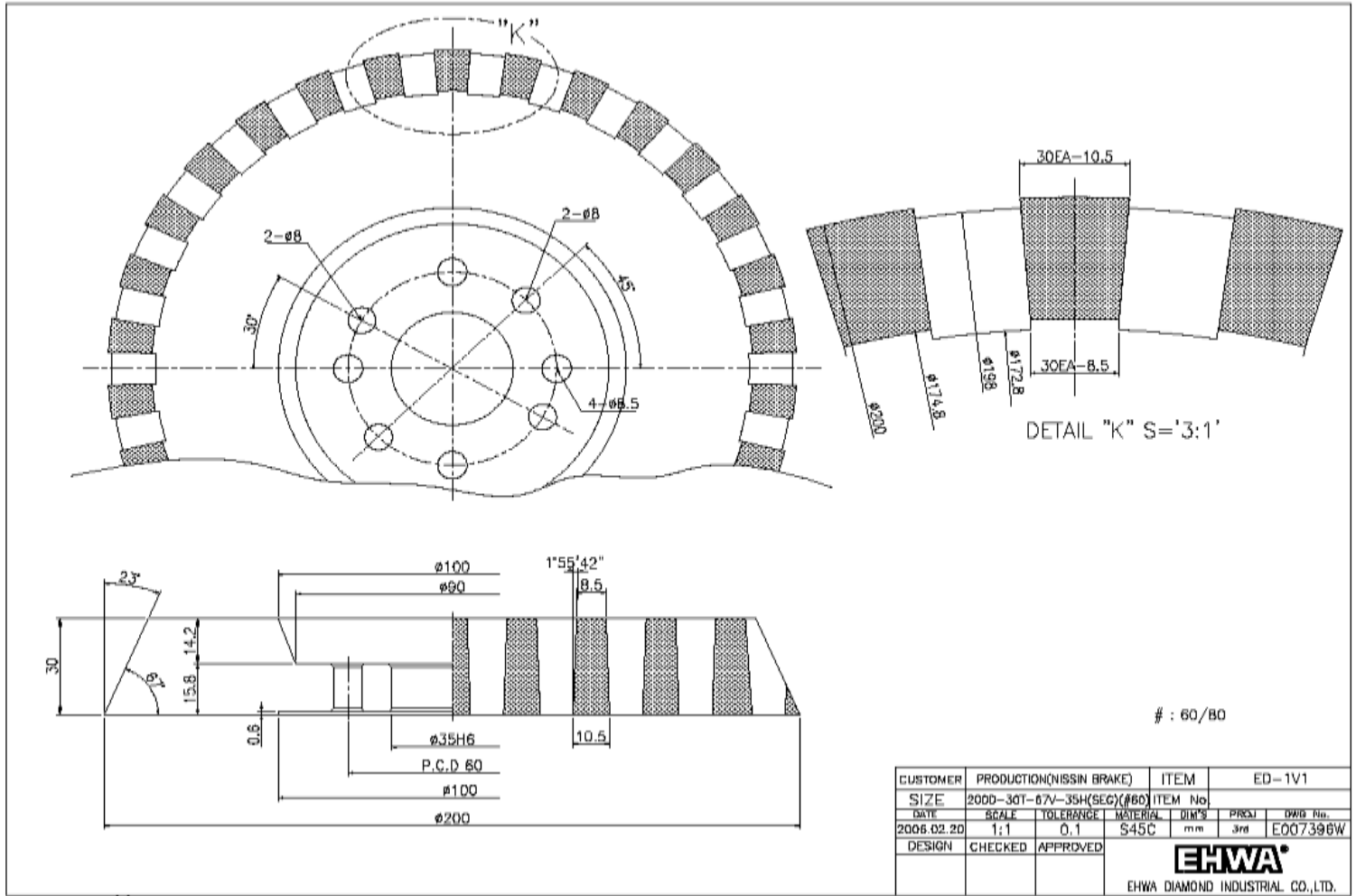
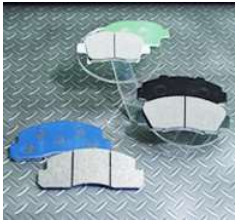

EGF-09-02-01(0)

Electroplated Diamond Wheels for Brake Pad

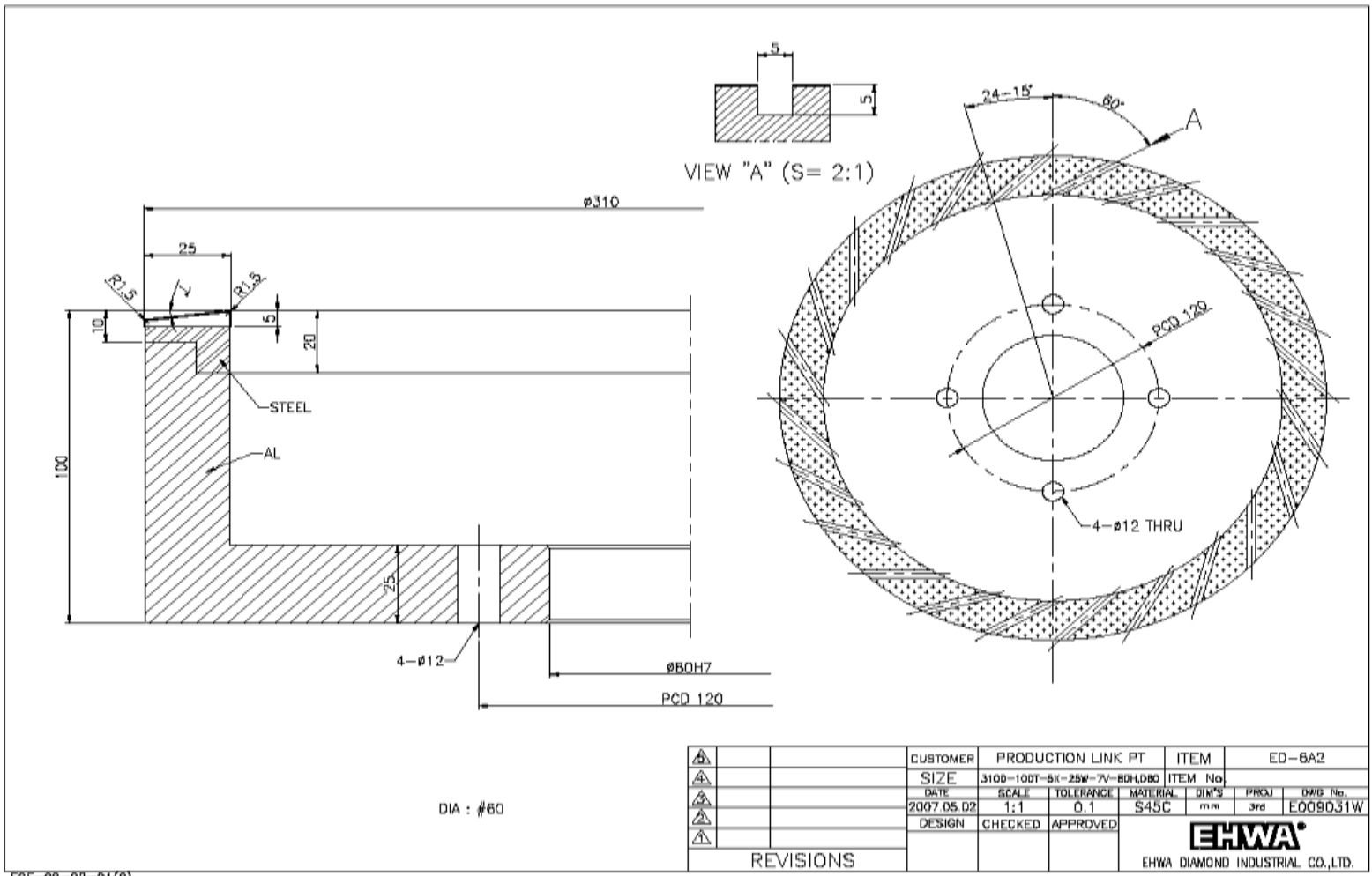
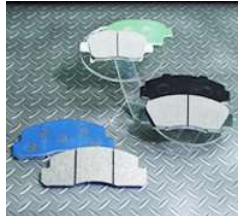

△		CUSTOMER	PRODUCTION LINK	PT	ITEM	ED-6A2									
△		SIZE	310D-100T-SK-25W-7V-BDH, D80	ITEM No.											
△		DATE	2007.05.D2	SCALE	1:1	TOLERANCE	0.1	MATERIAL	S45C	DIM'S	mm	PROJ	3rd	DWG No.	E009031W
△		DESIGN	CHECKED	APPROVED											
REVISIONS															
														EHWA® EHWA DIAMOND INDUSTRIAL CO., LTD.	

EGF-09-02-01(0)

Electroplated Diamond Wheels for Brake Pad

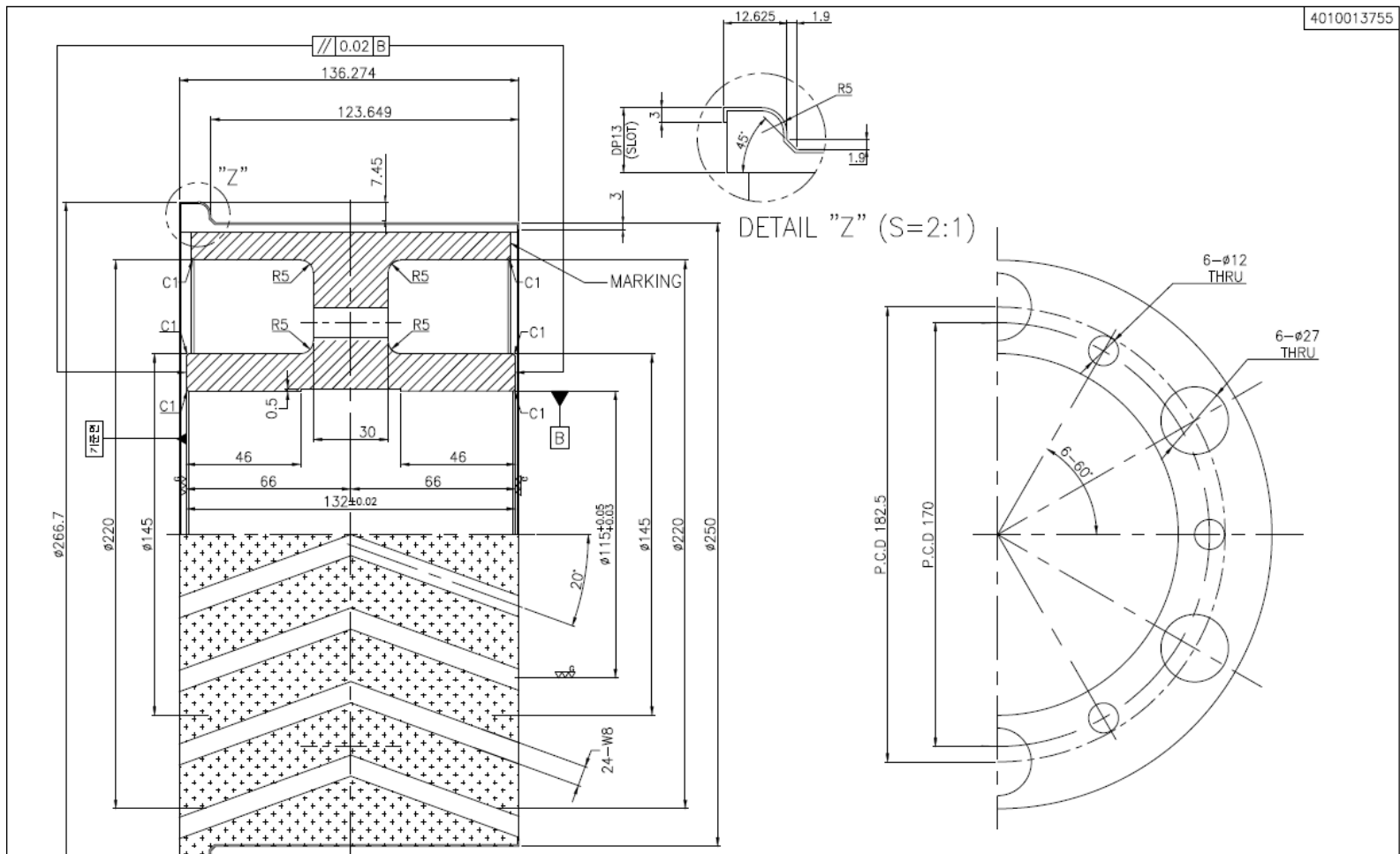
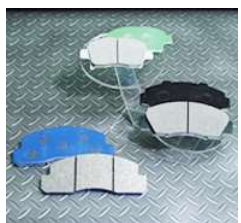

4010013755

△		CUSTOMER				ITEM	ED-1A1	
△		SIZE	266.7D-136.27T-115H, D30			ITEM No		
△		DATE	SCALE	TOLERANCE	MATERIAL	DIM'S	PROJ	DWG No.
△			1:1		S45C	mm	3rd	E026014W
△		DESIGN	CHECKED	APPROVED				
△		REVISIONS				EHWA [®] EHWA DIAMOND INDUSTRIAL CO.,LTD.		

EGF-09-02-01(0), A2

Electroplated Diamond Wheels for Brake Pad

4010430440

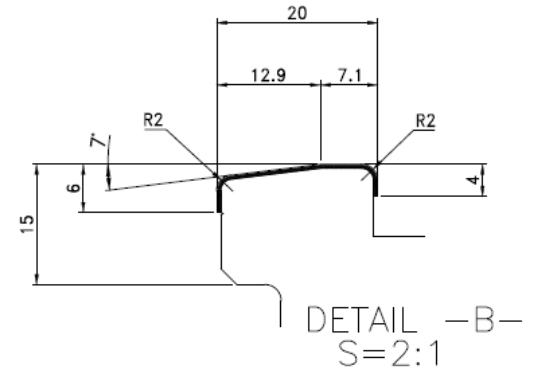
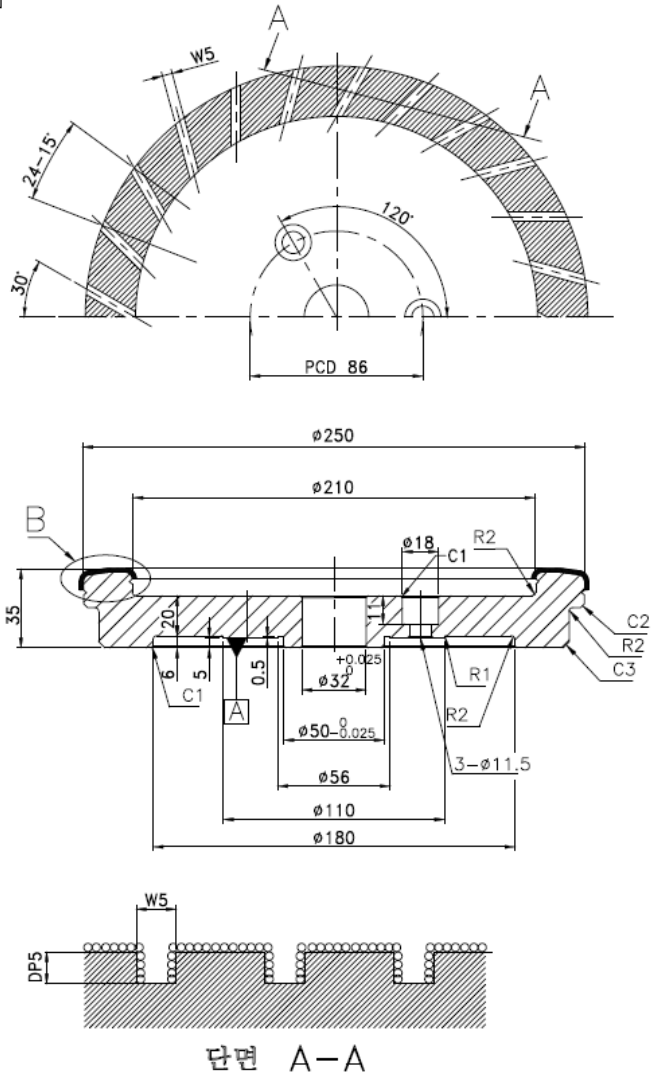
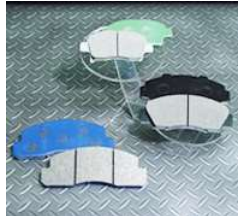

△		CUSTOMER		ITEM	ED-6A2		
△		SIZE	250D-20W-7.1ST/7V-32H		ITEM No.		
△		DATE	SCALE	TOLERANCE	MATERIAL	DIM'S	PROJ DWG No.
△			0.5:1		S45C	mm	E022891W
△		DESIGN	CHECKED	APPROVED	 EHWA DIAMOND INDUSTRIAL CO.,LTD.		
△		REVISIONS					

EGF-09-02-01(0), A3

Electroplated Diamond Wheels for Brake Pad

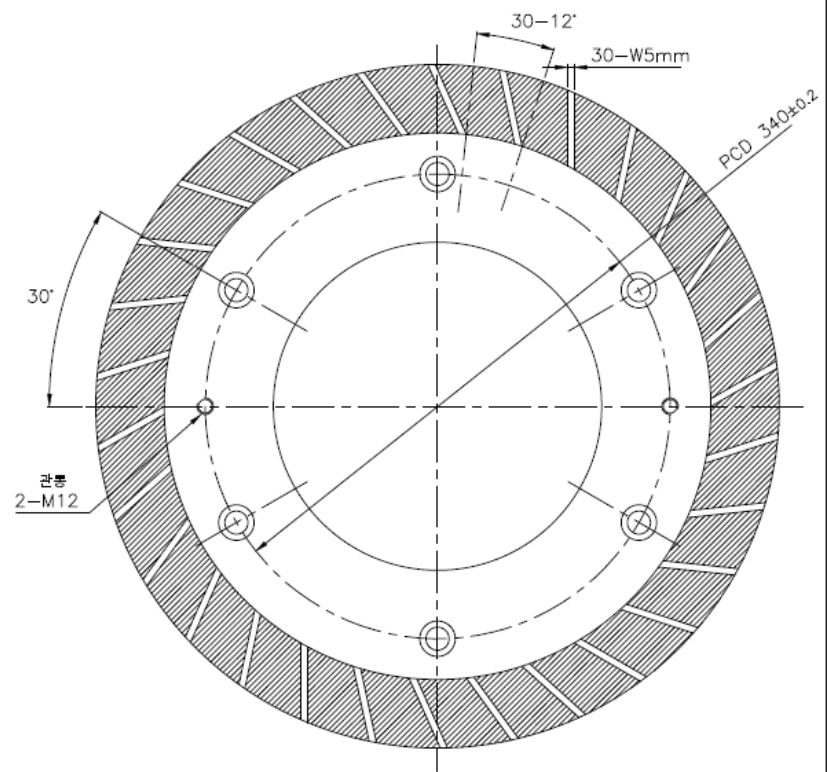
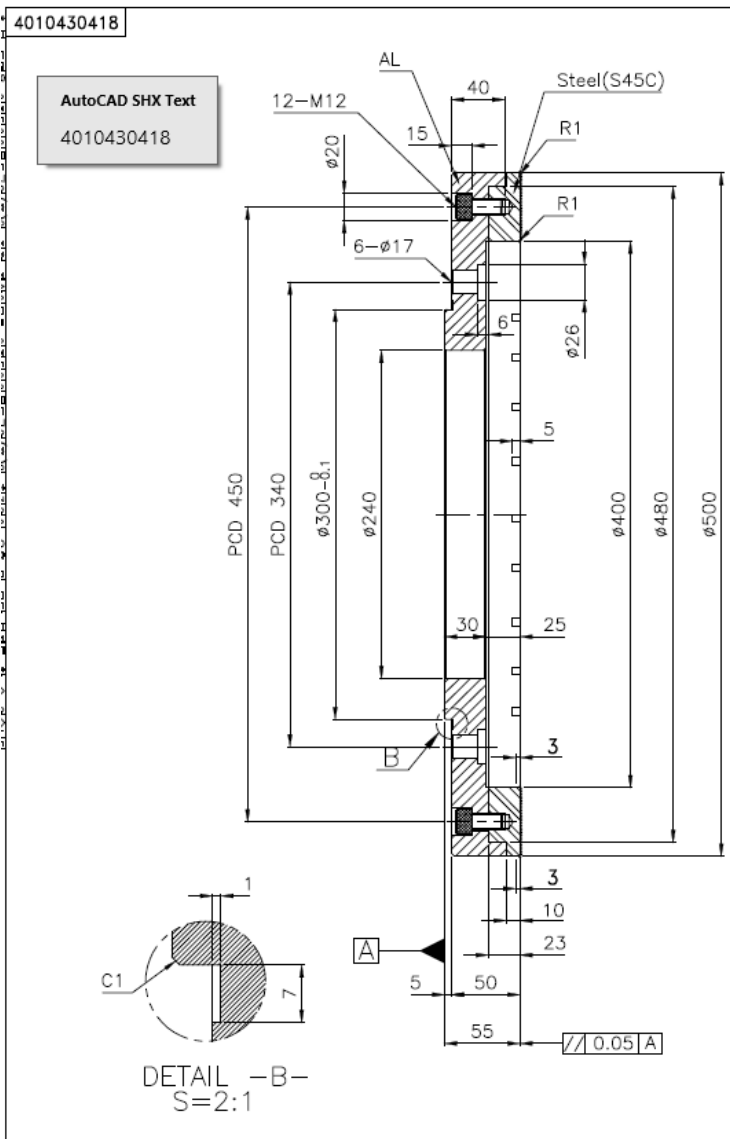
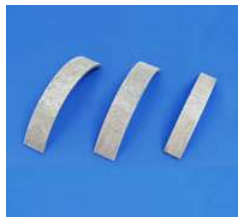

△		CUSTOMER	500D-55T-50W-240H		ITEM	ED-6A2	
△		SIZE	500D-55T-50W-240H		ITEM No		
△		DATE	SCALE	TOLERANCE	MATERIAL	DIM'S	PROJ. DWG No.
△			0.3:1		SL+AL	mm	E021488W
△		DESIGN	CHECKED	APPROVED			
△		REVISIONS			 EHWA DIAMOND INDUSTRIAL CO.,LTD.		

EGF-09-02-01(0), A3

THIS DRAWING CAN NOT BE COPIED OR DISCLOSED IN WHOLE OR IN PART WITHOUT THE EXPRESS WRITTEN CONSENT OF EHWA DIAMOND INDUSTRIAL CO.,LTD.

BSL Wheel for Brake Pad

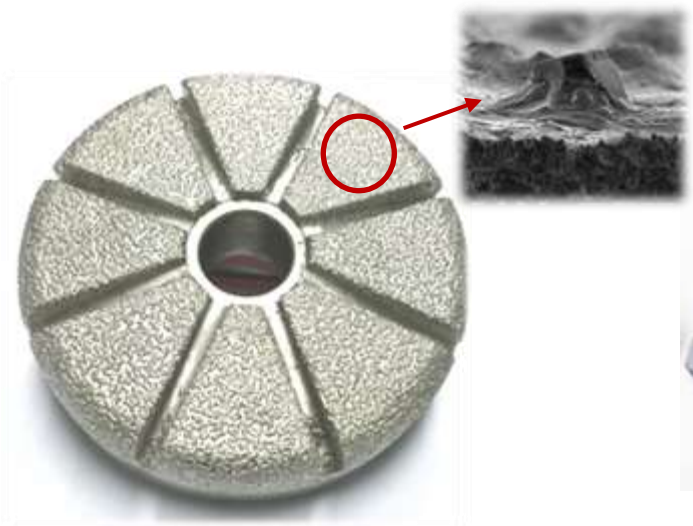

SHAPE OF WHEEL



WORKPIECE (Brake Disc Pad)

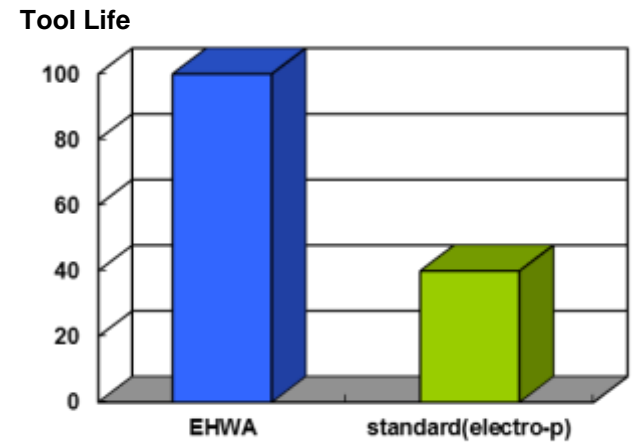

Test Result

TYPE	DIAMETER	T	GRIT SIZE	BOND
MD-6A2	φ150	30	#30~#50	BSL