

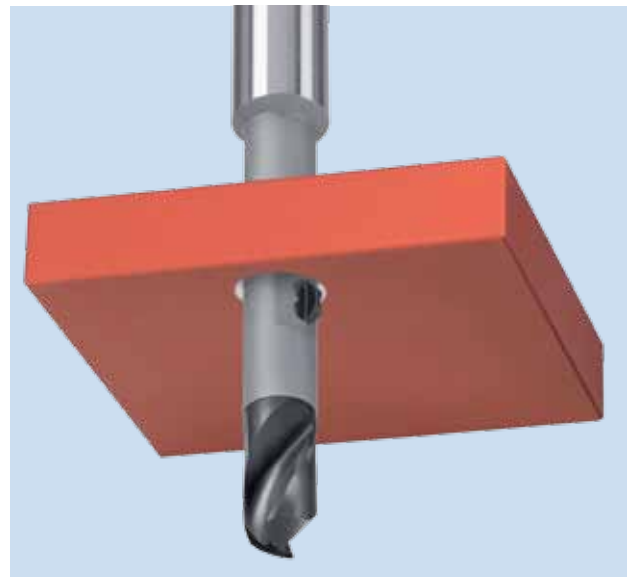

One Operation

For Front and Back Deburring, Chamfering,
Drilling and Countersinking

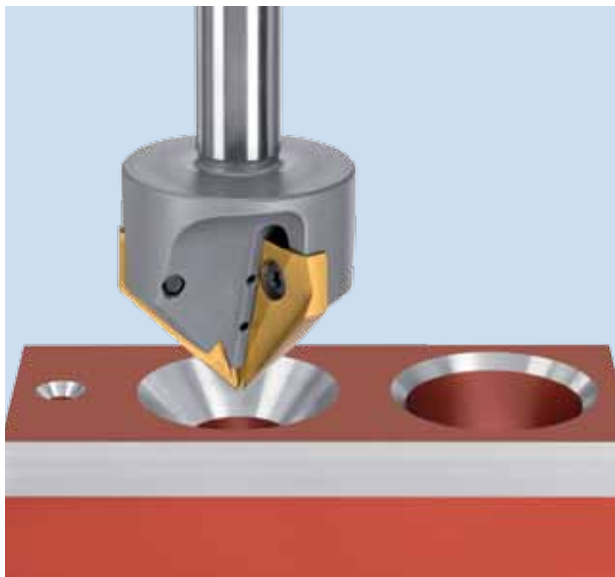
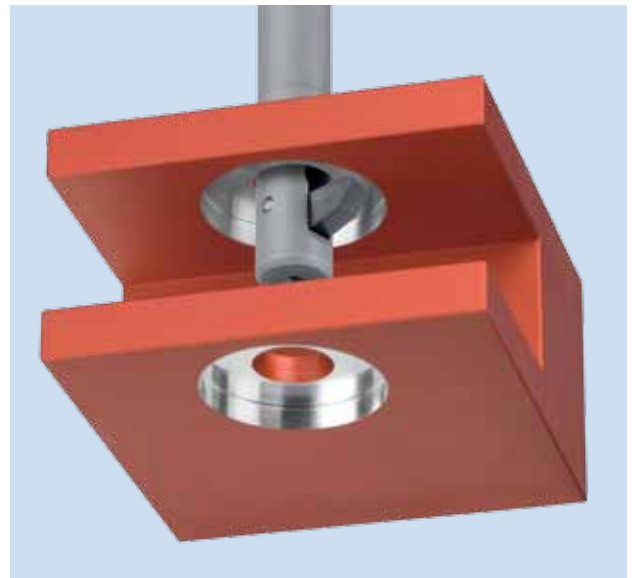
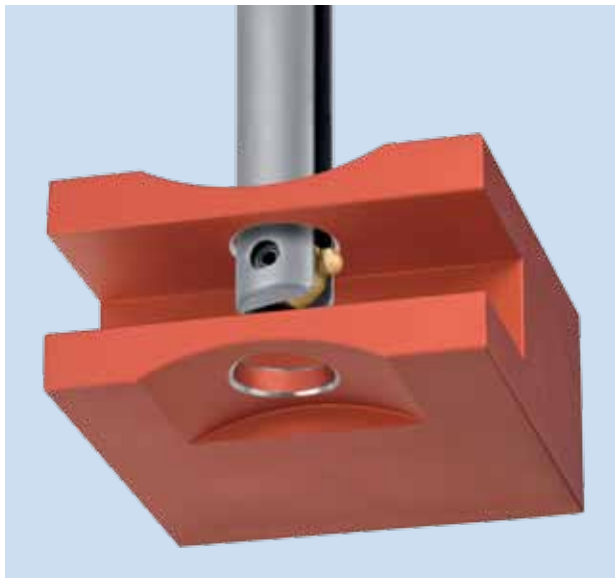

www.HeuleTool.com



Catalog No. HTC015



HEULE+
PRECISION TOOLS

The Innovator and Quality Leader
in the Cutting Tool Industry since 1961

Innovative Tools with Timesaving Results

Founded in 1961 by Heinrich Heule in the Rhine Valley of eastern Switzerland, HEULE continues to be a world leader in manufacturing of chamfering and deburring tools. After serving the European community for over 25 years, HEULE expanded to the United States. Heule Tool Corporation has been providing high quality chamfering and deburring tools to the North American market since 1988.

HEULE is committed to the values of quality, precision and service. Competent service, fast delivery times and customized solutions are the highest priorities. From all ranks, HEULE's committed and motivated expert staff carry out their work with reliability and professionalism. Customer's worldwide attest to the high quality standard HEULE provides and continually improves through innovative ideas and sophisticated technology.

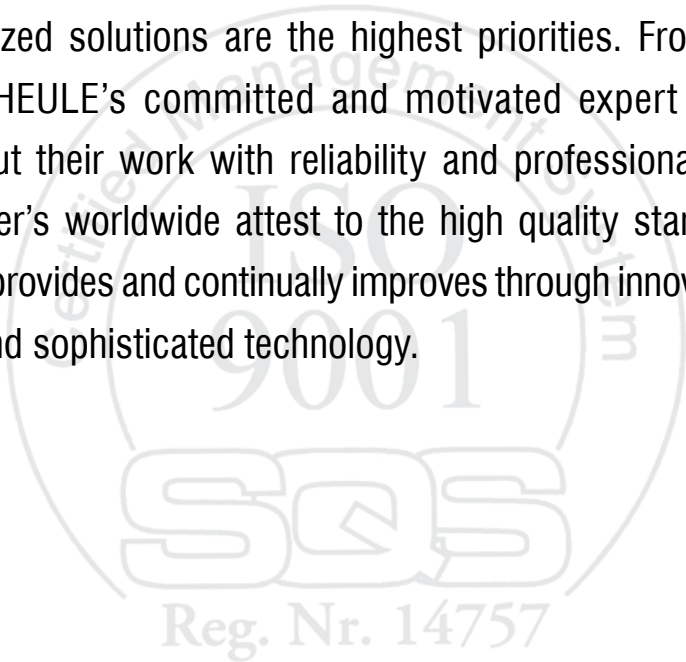

ONEOPERATION

HeuleTool.com (513) 860-9900



Product Application Guide	Pgs 05-07	Series 0 Drill/Chamfer	Pg 117
Case Studies & Best Practices	Pgs 08-22	Series 1 Drill/Chamfer.....	Pg 118
COFA – Elliptical Deburring Tool	Pgs 23-54	Series 2 Drill/Chamfer	Pg 119
Series 2	Pgs 26-27	Series Y, Z Drill/Chamfer/Countersink.....	Pg 120
Series 3	Pgs 28-29	Series 0 Drill/Chamfer/Countersink	Pg 121
Series 4	Pgs 30-31	Series 1 Drill/Chamfer/Countersink	Pg 122
Series 5	Pgs 32-33	Series 2 Drill/Chamfer/Countersink	Pg 123
Series 6	Pgs 34-35	Programming Information.....	Pgs 124-126
Series 8	Pgs 36-37	Spare Parts	Pg 127
Series 12	Pgs 38-39	DEFA – Precision Chamfering	Pgs 129-154
Series 12OS.....	Pgs 40-43	Series 02-06.....	Pgs 132-133
Cassette.....	Pgs 44-45	Series 07-09.....	Pgs 134-135
Programming Information.....	Pgs 46-47	Series 10-11	Pgs 136-137
Changing Blades.....	Pgs 48-51	Series 12-13	Pgs 138-139
Troubleshooting.....	Pg 52	Series 14-15	Pgs 140-141
Blade Options	Pg 53	Series 16-17	Pgs 142-143
SNAP – Universal Chamfering Tool	Pgs 55-90	Series 18-19	Pgs 144-145
MICRO SNAP – Micro Chamfering Tool	Pgs 55-68	Series 22-24	Pg 146
Series 2	Pgs 58-59	Series 26-28.....	Pg 147
Series 3	Pgs 60-61	Series 30-32.....	Pg 148
Series 4	Pgs 62-63	Blade Options	Pg 149
Changing Blades.....	Pg 64	Setting ØD2 Dimension	Pg 150
Technical Information.....	Pg 65	Programming Information.....	Pgs 151-152
Programming Information.....	Pgs 66-67	Technical Information.....	Pgs 153-154
SNAP – Universal Chamfering Tool	Pgs 69-90	GH-K – Chatter Free Countersinking	Pgs 155-160
Series 5	Pgs 72-73	Ø25 Tool	Pg 158
Series 8	Pgs 74-75	Ø45 Tool	Pg 159
Series 12	Pgs 76-77	Programming and Changing Blades.....	Pg 160
Series 20	Pgs 78-79	BSF – Back Counterboring and Spotfacing	Pgs 161-196
Snap 5 Cassette.....	Pgs 80-81	Series A	Pg 163
Snap 35 Cassette.....	Pgs 82-83	Series B.....	Pgs 164-165
Series 5 Tapped Holes.....	Pg 84	Series C	Pgs 166-167
Blade Options.....	Pgs 85-86	Series D	Pgs 168-170
Technical Information.....	Pg 87	Series E.....	Pgs 171-175
Programming Information.....	Pgs 88-89	Series F.....	Pgs 176-181
Troubleshooting.....	Pg 90	Series G.....	Pgs 182-187
VEX-S – Combination Drill/Chamfer	Pgs 91-104	Spare Parts	Pgs 188-190
Series 1xd.....	Pgs 94-95	Technical Information.....	Pg 191
Series 2xd.....	Pgs 96-97	Programming Informaiton.....	Pgs 192-193
Programmming Information.....	Pgs 98-99	Blade Change	Pg 194
Spare Parts	Pg 100	SOLO – Automatic Spotfacing	Pgs 197-206
Change Drill	Pg 101	SOLO 1900 Programming.....	Pg 202
Troubleshooting.....	Pgs 102-102	SOLO 2 Programming.....	Pg 203
VEX-P – Combination Drill/Chamfer	Pgs 105-112	Technical Information.....	Pgs 204-205
Series C	Pg 108	GH-Z/E – Automatic Counterboring	Pgs 207-211
Series D.....	Pg 109	Programming Information.....	Pgs 210-211
Technical Information.....	Pg 110	APPENDIX – Reference Materials	Pgs 212-219
Programming Information.....	Pg 111	Application Data Sheets	Pgs 213-216
Change Drill	Pg 112	Materials Reference Chart	Pg 217
COMBI – Combination Drill/Chamfer	Pgs 113-128	Metric to Inch Conversion Chart.....	Pg 218
Series Y, Z Drill/Chamfer	Pg 116	TOOL RECOMMENDATIONS	PG 219

COFA

Universal Deburring Tool

The COFA tool removes burrs on the front and back of a drilled through-hole on even and uneven surfaces in a single cycle.

- Radial edge breaks on flat or uneven surfaces.
- Deburr through holes on irregular surfaces up to 30°.
- Typical edge break range .005-.015".
- Used on all materials; aluminum to nickel alloy.
- Available in sizes 2mm (.080") and up.

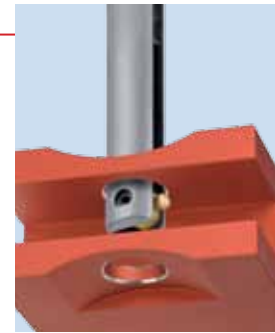
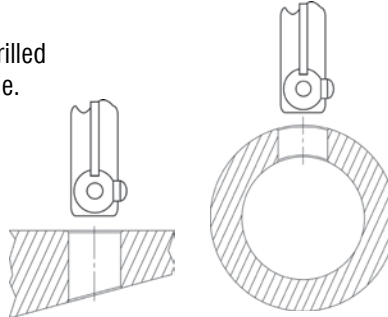

Pages 23-54

SNAP

Simple Front/Back Chamfering Tool

The SNAP tool is easy to use and offers quick blade change, which makes it practical for any manufacturing environment.

- Creates standard 90° controlled chamfers.
- Most economical and fastest front and back chamfer tool.
- Absolutely safe for reamed and finished holes.
- Cutting blade options offer controlled chamfer sizes: .010", .020", .030" or .040" x 45°.
- Used on all materials under 30Rc.
- Available in sizes 2mm (.080") and up.

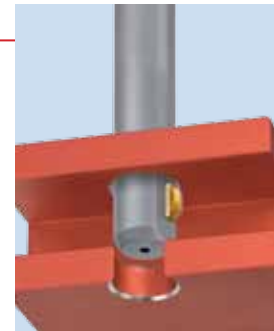
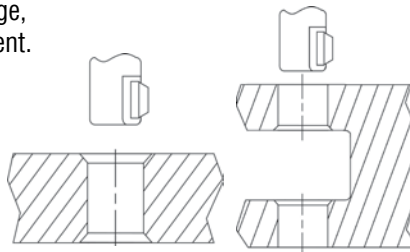

Pages 55-90

VEX-S

Combination Front/Back Chamfering and Drilling

The VEX-S tool combines a replaceable solid carbide high performance twist drill with Heule's patented SNAP chamfering system to make drilling and front and back chamfering in a single operation possible.

- Standard stock tooling for 1x and 2x diameter depth.
- Replaceable drill tip can be reground and recoated.
- Used on common steel and non-ferrous applications.
- Available in sizes 5-12.7mm.

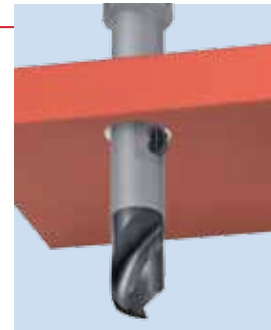
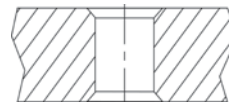

Pages 91-104

VEX-P

Combination of Drilling and Front/Back Chamfering

The VEX-P tool combines a replaceable solid carbide high performance drill tip with HEULE's patented SNAP chamfering system to enable drilling and front and back chamfering in one operation.

- VEX drill geometry for better chip control
- Quick and easy drill tip and chamfer blade replacement
- No presetting between drill changes
- Sizes 11.0-17.0mm (.433-.669") available from stock
- Bore depths up to 1.5 times diameter

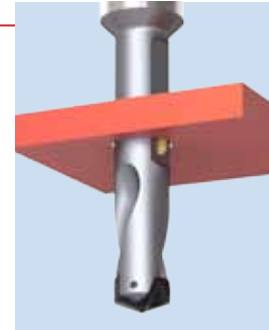
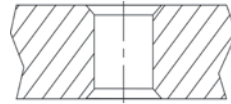

Pages 105-112

COMBI

Combination Chamfering and Drilling

The COMBI tool combines front and back chamfering and drilling to save time, money, and space on your machining center.

- Stock 1x diameter tooling accepts standard spade drills.
- Custom made tooling for boring, drilling, and countersinking with chamfering.
- Ideal for automotive applications: e.g. wheel and disc brake manufacturers.
- Available in sizes 9.5-35mm.

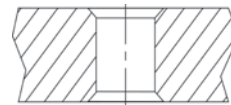

Pages 113-128

DEFA

Precision Front/Back Chamfering

Double bladed DEFA chamfering tools create pre-adjusted front and back chamfers in a single operation without stopping or reversing the spindle.

- Sliding-surface blade geometry prevents damage to finished hole surfaces.
- Precise, adjustable chamfer sizes up to .050" x 45°.
- Used on all materials, cast steel to nickel base materials.
- Available in sizes 4-44.5mm.

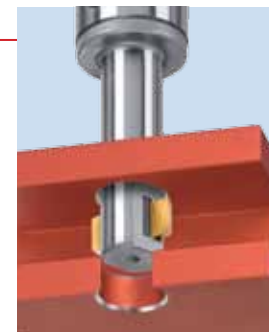
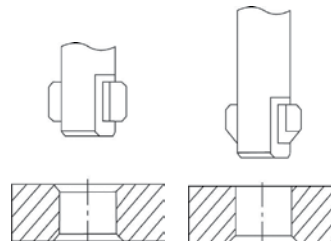

Pages 129-154

GH-K

Precision Chatter-Free Countersinks

The GH-K countersink blades are precision ground as a matched set to achieve unmatched countersink finishes.

- Totally chatter-free.
- Suitable for chamfer milling.
- Used in manual and CNC applications.
- Used on cast iron, aluminum and other long chipping material.
- Available with a 3-45mm countersink range, 60°, 82°, 90° and 100°

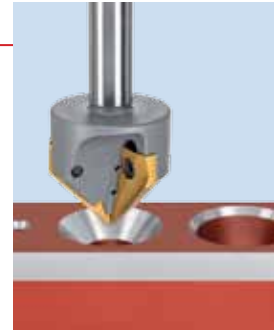
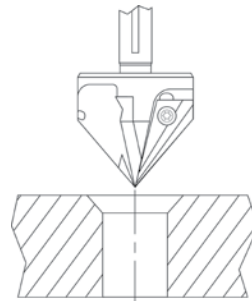

Pages 155-160

BSF

Back Spot Facing Tool

The BSF backspotfacing tool is an easy to use tool concept that allows back spotfacing or counterboring in one operation without turning the workpiece

- Large ratio automatic back counterboring and spotfacing tool
- Usable for counter bores up to 2.3xd
- Very simple to use
- Especially usable for CNC machining
- Through coolant minimum 280 psi
- Available for bore sizes 6.5-20.5mm

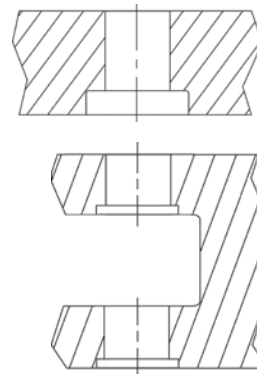

Pages 161-196

SOLO

Automatic Front/Back Counterboring

The SOLO tool is an easy to program tool for automatic back spotfacing through holes with positive control in a single operation.

- No anti-rotation device or machine adaptations needed.
- No change of spindle rotation, no contact mechanism and no coolant pressure required for blade activation.
- Counterbore sizes up to 2x hole diameter -1mm.
- Available for bore sizes 8-30mm

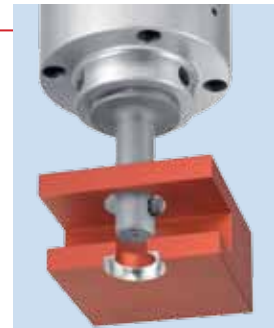
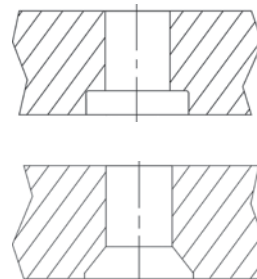

Pages 197-206

GH-Z/E

Automatic Front/Back Spotfacing Systems

The GH-Z/E is a twin bladed front and back counterboring tool that makes back spotfaces, large countersinks, and precision forms.

- Used in large bore applications and difficult to cut situations.
- No chip interference with blade activation.
- Reversing the spindle activates the blades, blades do not flip out.
- Counterbore sizes up to 2x hole diameter -1mm.

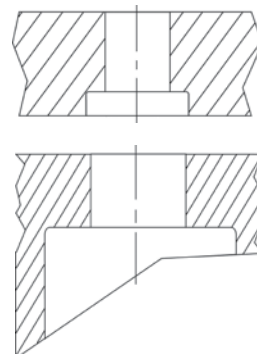

Pages 207-211

HTC015



MICROCOFA

Small Precision Front/ Back Deburr Solutions for Small Hole Operations

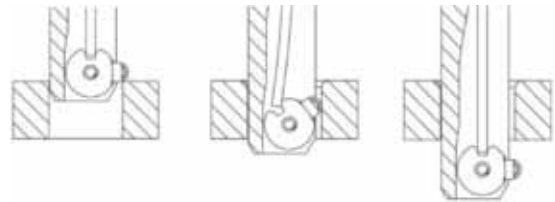

The MICRO SERIES, for COFA 2 and 3, is for all purpose deburring of through holes 2mm-4.1mm (.079"-1.61"), front and back, in a single pass. Heule's MICRO COFA deburring tool is the answer for today's manufacturers requiring more simple and flexible solutions without sacrificing quality or tool life.

MICRO COFA is a very simple tool for deburring through holes on even or uneven parts from the top and bottom without reversing the spindle, dwelling, or indexing the part. The MICRO COFA tool offers a simple to use, high quality deburring tool with Carbide inserts coated with TiAIN to meet today's manufacturing needs.



*The COFA Family
2mm - 41mm (.079" - 1.614")*

Study Details

TOOL

COFA3-3.6-S with blade C3-M-0011-A (back cutting only)
Theoretical deburring Ø4.2

PRODUCTION

2400 per day with 24 holes in tube

MACHINE

CNC machining center

MATERIAL

Similar to St52 steel with approximately 700N/mm²

HOLE SIZE

Cross hole Ø3.6 with main Hole Ø12.0 which are 90° to each other.
Need to be back deburred (unevenness on a Ø4.2mm deburring diameter to Ø12.0 main hole = 0.37mm or 10.24°)



BLADE

Blade life is over 4500 holes

PARAMETER

s= 2500 RPM, f=0.05mm/rev.
S-Spring, flood coolant

PRODUCT SECTION **PG. 23**



COFA

*Consistent Deburring
Through Holes on
Even & Uneven
Surfaces in Any Material*

Sequence of operation:

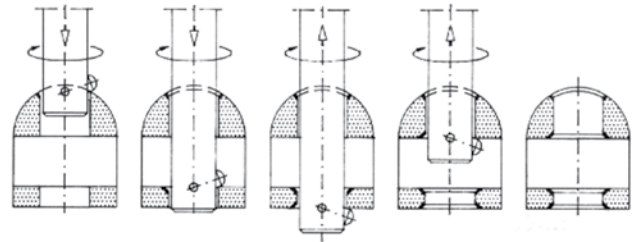

Study Details



TOOL
COFA Tool

PRODUCTION
1,400 parts / day (2 holes per part)

MACHINE
CNC Machining Center

MATERIAL
Low Carbon Steel

HOLE SIZE
Ø.630mm hole requiring even edge
break of .005-.015" on all 4 surfaces

DETAILS
Tool COFA12-599-Z
Speed 1180 RPM
Feed 0.3mm/rev
Life 4000-5000 parts

CYCLE TIME
12 seconds per part

REPLACING
Hand benching

PRODUCT SECTION **PG. 23**

Tired of inconsistent hole chamfers? Our COFA tools produce consistent edge breaks EVERY time, front and back, in one pass. No adjusting screws or setting requirements are necessary. Each tool is sized for your application and material. Operators might be skeptical... until they see it run.

"After seeing parts made by the HEULE tool, our customer will no longer accept hand benching of their parts."

The COFA tool removes the burrs from elliptical bores created when drilling into round parts, contoured surfaces, or angled faces. Cuts a tapered radius rather than an angled chamfer.

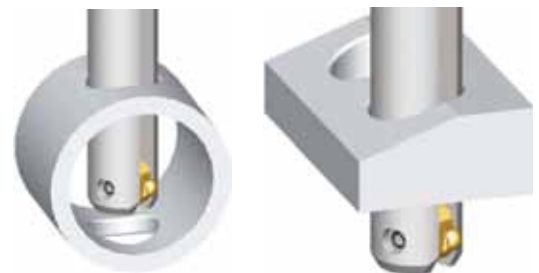

HTC015

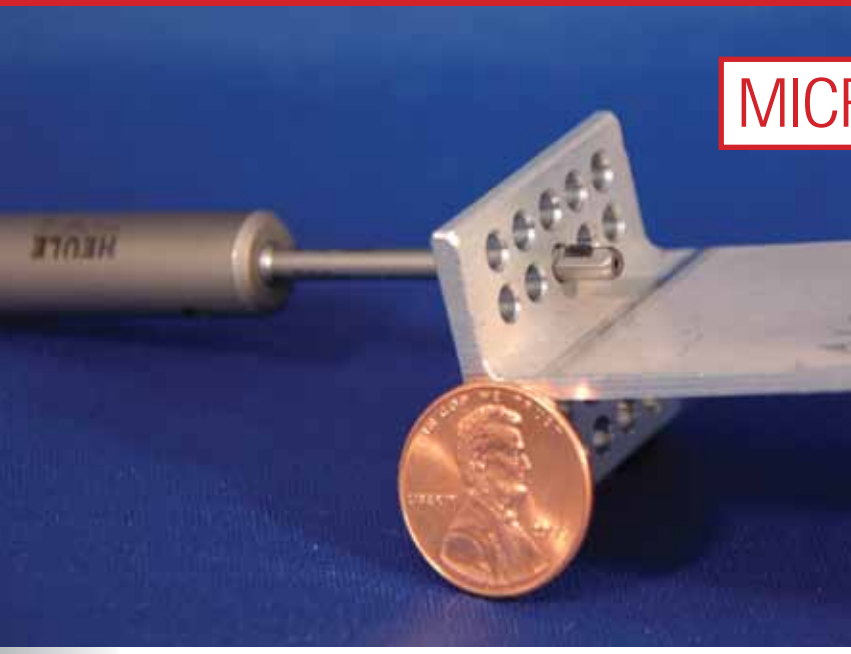

MICROSNAP

Small Precision Front/Back Chamfer Solutions for Small Hole Operations

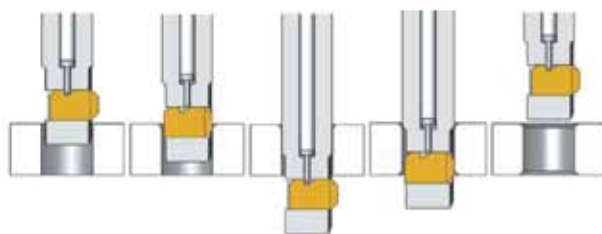

Study Details

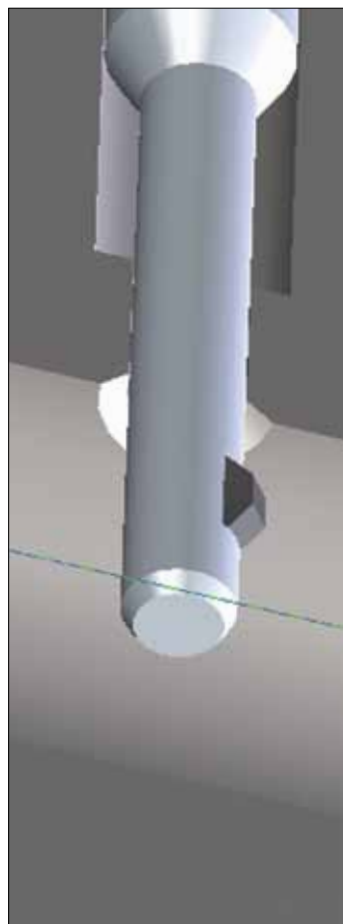

TOOL
MICRO SNAP front & back chamfer tool

PRODUCTION
450 pc/wk 6x holes/part

MACHINE
CNC Vert. machining centers

MATERIAL
Case harden steel

HOLE SIZE
Ø2.4 +/- .05 26.5mm deep breaking into Ø10mm diameter cross hole

DETAILS
Tool MICRO Spec Ø2.25
Speed 3300 RPM
Feed .045mm/rev
Blade GH-Q-M-42671
Ø2.8mm x 60° Carbide TiAlN back only cutting 60°

OUTCOME
Consistent deburring improving part quality

PRODUCT SECTION PG. 55

The Micro tools expands Heule Tool's ability to offer quality, automated deburring tools with multiple carbide blade choices for front and back chamfers in almost any material. Our standard inserts are ground to exact chamfer sizes which will not damage or mark the through hole.

"The Micro Series tools are REALLY working great..."

This automotive supplier is deburring several small cross holes in a critical component. The holes required only a break edge, but due to the difficulty to machine material and cross hole situation, carbide "back cutting only" blades were used.

Using our Patented MICRO DF-Geometry allows our tools to cut consistent chamfers in INCONEL, TITANIUM and other Super Alloy steels.

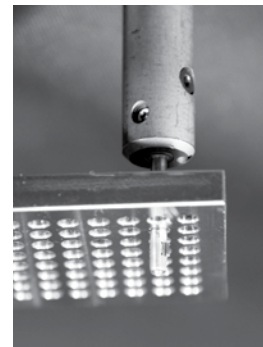



BEFORE

AFTER

SNAP

Fast and Accurate SNAP Tooling is Able to Produce Large Chamfers with No Secondary Burr Issues

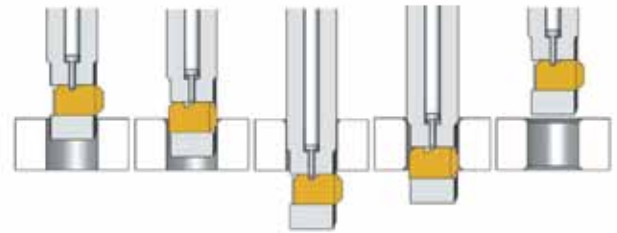

Study Details



TOOL
SNAP front & back chamfer tool

PRODUCTION
8,000 parts / week

MACHINE
CNC Vert. machining centers

MATERIAL
Low carbon steel

HOLE SIZE
Ø13.0mm hole requires 0.5mm max chamfer 2x places with no secondary burr

DETAILS
Tool SNAP12-512
Speed 280 SFM
Feed 0.2mm/rev
Life 10,500+

REPLACING
Secondary operation

OUTCOME
Consistent chamfer to specification

Our standard chamfering system takes the guess work out of producing front and back chamfers. The insert geometry is ground to the exact chamfer sizes and capable of running 2-3x faster than competitive tooling. This low carbon steel automotive component was drilled and reamed leaving behind heavy burrs causing problems with automated assembly machines and eventually transmission quality.

“We got the consistency we needed to keep our production going, AND saw a \$45,000/yr saving in time and labor.”

The heavy burr causing the problem was removed using a SNAP tool with front and back cutting blade. With clean and chamfered edge breaks, assembly problems were eliminated.

Each Standard SNAP tool comes with the choice of 4 chamfer sizes: 0.25, 0.5, 0.75 and 1.0mm. Can be used with threaded / tapped holes.



HTC015



VEX-S

Drill & Front/Back Chamfer in ONE STEP. Rotors, Hubs, Axle Flanges...



Study Details



TOOL
VEX-S

PRODUCTION
1,000,000 / yr

MACHINE
Emag multi spindle machine

MATERIAL
Steel 52, 7mm thickness

HOLE SIZE
Ø8.0mm; hole requires chamfer size
9.5mm x 90° front & back

DETAILS
Tool Multiple
Speed 3700 RPM
Feed 0.14mm/rev (0.006 IPR)
Life Drill life 4-5,000 holes

REPLACING
Tool Drill & 2 countersinking
operations.

PRODUCT SECTION **PG. 91**

Cycle time is always a premium and so is quality. Each time tooling can be combined into one operation, while at the same time producing a better product, everyone wins. The VEX tool combines drilling and front/back chamfering into a single tool. Save setup time, cycle time and tool space.

“We saved over \$60,000 just by eliminating a second machine operation.”

The VEX-S drill geometry limits chip wrapping issues or interference with any mechanical operations of the deburr operations. The single bladed front/back SNAP chamfer blade is easy to use and offers quick change features so the tools never leave the machine. Most common application is deburring bolt holes in flanges. From 5mm to 12.7mm.

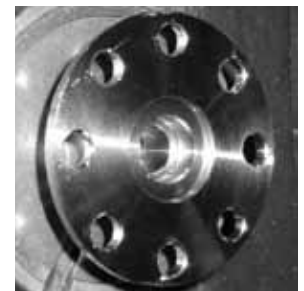

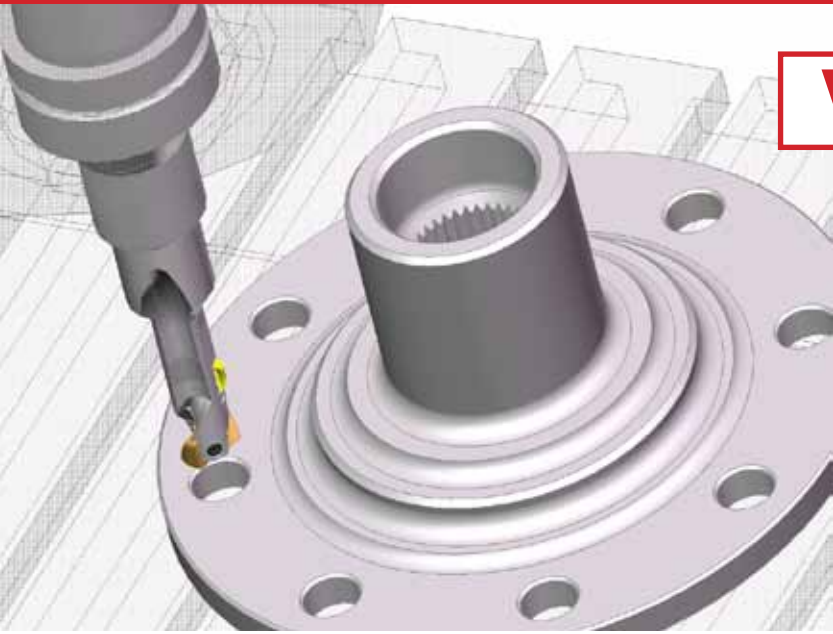

VEX-P

Combination of Drilling and Front/Back Chamfering in One Operation.

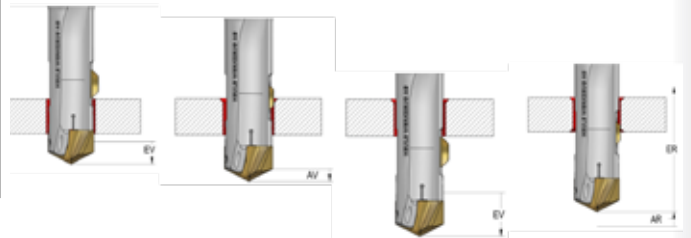

Study Details



TOOL
VEX-P

PRODUCTION
30,000 parts per month

MACHINE
Vertical CNC

MATERIAL
1050 Steel

HOLE SIZE
Ø13.0mm (.512") drilled front and back chamfered in one single operation

DETAILS
Tool:
Speed: VEX-P SNAP12 drill combi
Feed: 3720 RPM 500 SFM
VEX: 0.25 mm/rev (.0101" IPR)
Life: SNAP: 0.20 mm/rev (.008" IPR)
VEX: 4,500 holes/
SNAP: 13,500 holes

REPLACING
Solid carbide and secondary operation

PRODUCT SECTION **PG. 105**

The VEX-P tool combines a replaceable solid carbide high performance drill tip with HEULE's patented SNAP chamfering system to enable drilling and front and back chamfering in one operation.

"The Vex-P combination tool replaced two tools and cut our cycle time in half for that operation...."

For bores from diameters 11.00 mm to 17.0 mm (0.433 - 0.669") and bore depths up to 1.5 times diameter.



HTC015

COMBI

*The Fastest Multi-Task
Wheel Rim Tool on
The Market*

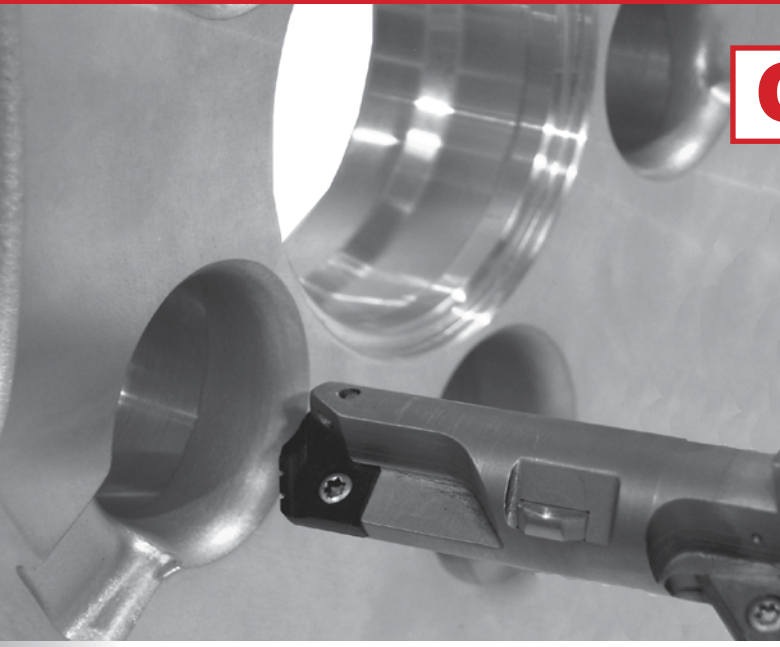
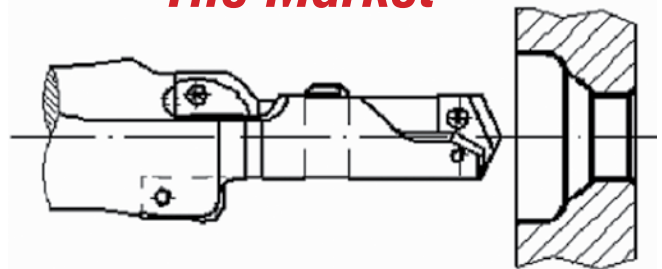

Study Details



TOOL
COMBI multi-task drill back chamfer tool with coolant through.

PRODUCTION
250,000 wheels / month

MACHINE
Horizontal Machining Centers

MATERIAL
Cast Aluminum 7%

HOLE SIZE
Ø15.7, 19.0 & 21.6mm; hole requires front countersink and counter bore Ø32.0mm & back chamfer.

DETAILS

Tool	Multiple
Speed	6500-10,500 (2,336 SFM)
Feed	0.3-0.4mm/rev (0.015 IPR)
Life	All drills, countersinks and deburr blades are changed every 8 days.

REPLACING
Circle Interpolation and wheel flip operations tool.

PRODUCT SECTION PG. 113

Our aluminum and steel wheel Multi-Tasking tools for the lug nut drill chamfer operations lead the industry in performance and efficiency. Capable of increasing part production with high performance, accurate drills, combined with HEULE's patented back chamfer SNAP system.

"The cycle time savings are huge... in one day alone we get 157 more wheels out of the cell."

All robot wheel cells that require back chamfers now use HEULE tools. Some tool holders have run over ONE MILLION holes. Also using COFA tooling for deburring uneven stem holes.





DEFA

Accurate Tooling for Front/Back Chamfers in Difficult Materials

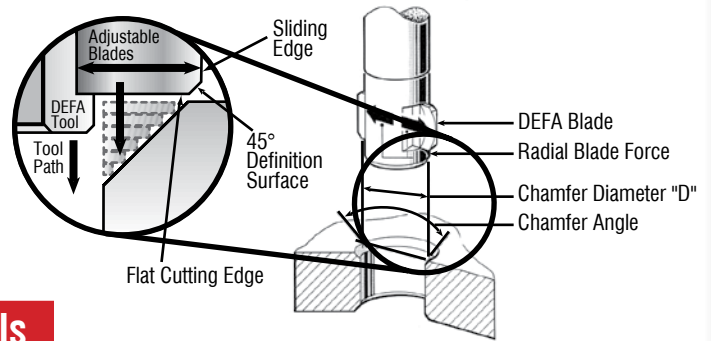

Study Details



TOOL
Twin bladed DEFA tools with coated carbide blades

PRODUCTION
2 parts / wk (360 holes / part)

MACHINE
NC Horizontal

MATERIAL
Inconel 718

HOLE SIZE
Ø.345 and Ø.401 requiring front/back break edge 0.005-0.015".

DETAILS

Tool	DEFA11-34-339 & DEFA13-30-390
Speed	60 SFM
Feed	0.002 IPR
Life	Blade life: 800-2000 holes
Chamfer	0.010"x90°

REPLACING
Manual bench operation, minimizing a potential ergonomic risk.

PRODUCT SECTION **PG. 129**

Tested and approved by the major jet engine and aircraft component suppliers, the DEFA tooling will not leave any witness mark inside your finish holes, and produces accurate front & back chamfer break edges in Titanium, Inconel and other Nickel alloys.

"...the Heule tooling took a 2 1/2 hour manual operation and reduced it to only 10 minutes."

The form blade set can be adjusted radially to exact required chamfer size; in most cases within +/- 0.003. The cutting blades are held inside the tool with HEULE's patented pin drive system. One blade cannot collapse without the other.



HTC015

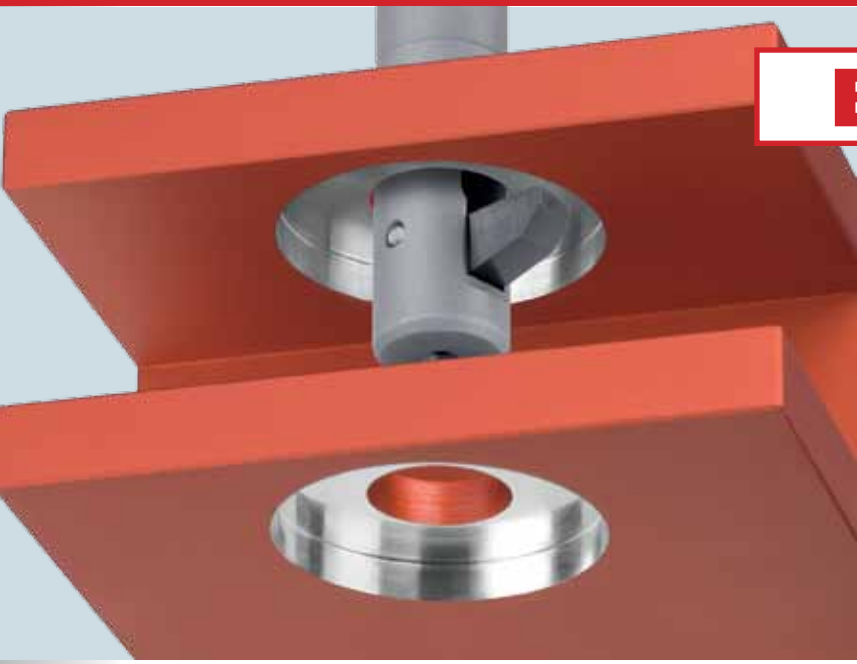

BSF

Large Ratio Automatic Back Counterboring & Spotfacing Tool

Blade Working Principle

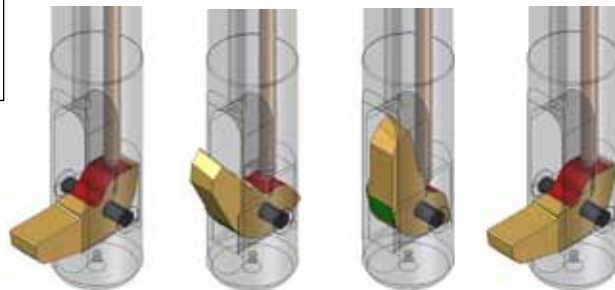

Study Details



TOOL
BSF 12.6 - 22.0 with working length 80 mm
Blade: carbide DLC coated

INDUSTRY
Automotive

WORK PIECE
Cylinder head

MATERIAL
Cast aluminum

APPLICATION
Bore: Ø12.6 mm
Spot face: Ø22.0 mm

PROCESSING
Spindle speed: 2000 rev/min
Feed: 0.05 mm/rev
Cooling: internal coolant
Coolant Pressure: 500 PSI
Shaving: short chips

REMARKS

Due to the interrupted cut, the tool was out of the recommended parameters, and was of concern. The customer took the risk and it was worth it. The interrupted cut caused chatter which was corrected with higher spindle speed.

PRODUCT SECTION **PG. 161**

Back Spotfacing up to 2.3 x Bore Diameter

The simple BSF tool concept allows back spotfacing or back counterboring in one operation without turning the workpiece, activated with through coolant.

The BSF spotfaces up to 2.3 times the bore diameter. Our standard range starts with holes as small as 6.5mm to 20.5 mm and designed to cut all materials.



Clean Surface Finish

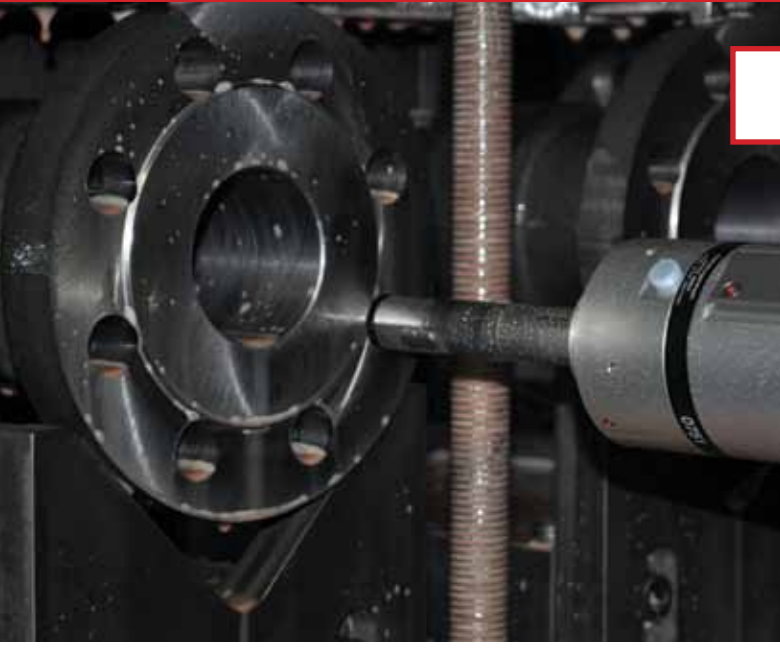

SOLO

High Production Automated Back Spotfacing Tool



Study Details



TOOL
Automated Back Spotfacing

PRODUCTION
4 or 8 bolt holes on the flanges of 316 stainless valves

MACHINE
Mazak Ultra 650 horizontal machining center

MATERIAL
Stainless Steel

HOLE SIZE
Ø34.8mm counter bore;
Ø19.05mm through hole

DETAILS
Tool SOLO 2
Speed 613 RPM
Feed .002 IPR
Life 420 holes
(indexable carbide)

REPLACING
Competitors hinge-type tool

PRODUCT SECTION **PG. 197**

The switch in tooling significantly reduced cycle time. Machining time on valve bottoms, which included boring the hole to size, drilling and back spotfacing, dropped from 39 minutes to 15. While this is running at the low end of the recommended speed and feed range, it was a vast improvement in productivity.

“So far we’ve run 420 counter bores, up from 32 on the old tool and we’ve only indexed the two-sided inserts once.”

Custom back spotfacing tools that can produce front and back spotfaces and counterbores allow for reduced cycle times and extended tool life. Capable of cutting nickel based alloys.



Rene 88

HTC015



GH-Z

Large Automated Back Counter Bore Solutions for the Power Generation Industry & Large Part Manufacturers



Study Details

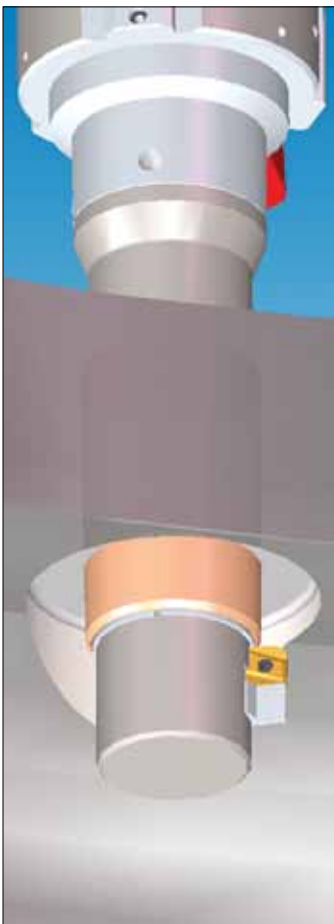

TOOL
Single Blade Automated Back Counter bore with Indexible Cutting Inserts

PRODUCTION
1-2 hubs / week (198 counter bores/ part)

MACHINE
Large vertical boring mill

MATERIAL
Cast Iron

HOLE SIZE
Ø39.0mm hole requires an Ø75.0mm back counter bore up to 15.0mm deep. (interrupted cut from casting variance)

DETAILS
Tool GH-E 50
Speed 390 RPM
Feed 0.1mm/rev (0.004 IPR) Full diameter counter bore depth... up to 15mm deep
Life (indexable) 1 part

REPLACING
Competitors flip-out style tooling

PRODUCT SECTION **PG. 207**

HEULE has been manufacturing the strongest and most reliable automated back counter bore tools for over 30 years. Some tools reach over several feet and can weigh over 50 lbs.

Large interrupted cuts created tool breakage problems for this customer slowing machine time. By purchasing a HEULE automatic back counter bore system the problem was solved.

"...increased production and shortened a 15 hour operation to only 2.5 hours."

This customer is currently running on two large boring mills with coolant through the spindle capability. Other common applications include; landing gear, crane and hoist components as well as hydro and other turbine manufacturers.





SPECIALS

*Custom Multi-Tasking
Easy and Cost Effective*



Study Details

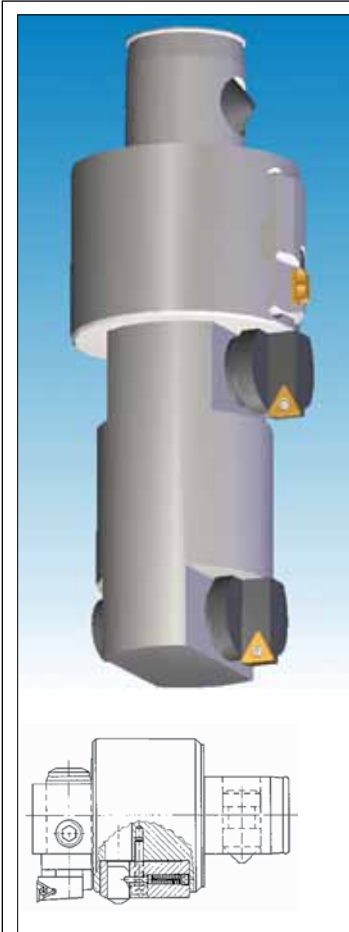

TOOL
Precision Mico Adjusting Boring Unit with SNAP chamfer cassette

PRODUCTION
300,000 / yr

MACHINE
Horizontal Machining Centers

MATERIAL
Cast Aluminum

HOLE SIZE
Ø76.2mm and Ø73.0mm; requires front/back chamfer of 74.1mm x 60°

DETAILS
Tool COMBI multi-task bore and front/back chamfer with std. deburr cassette chamfer blade 60 degree carbide diamond film cutting blade.
Speed 1070 SFM (1,400 RPM)
Feed 6 IPM
Life 10,000+

REPLACING
Cycle time reduced 20% (1.5 min)

PRODUCT SECTION → PG. CALL

Our SNAP & COFA cassettes and custom-made tooling make ordinary boring operations into money making processes by saving space and time. Any large bore operation above 1" can utilize a HEULE front & back chamfer cassette.

"We saved approximately \$150,000 a year by cutting over 1 min./part out of production of 300,000 parts a year."

Challenge: The cast surface where the 76mm bore was produced could move in location as much as 6mm. The spring loaded HEULE chamfer cartridge with special 60 degree cutting blades produced the same size chamfers front and back regardless of surface location.

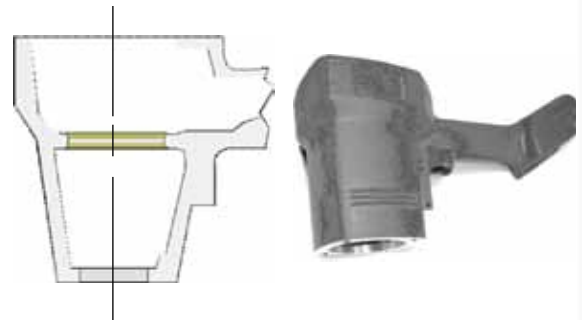

HTC015

SPECIALS

*Custom Multi-Tasking
Easy and Cost Effective*

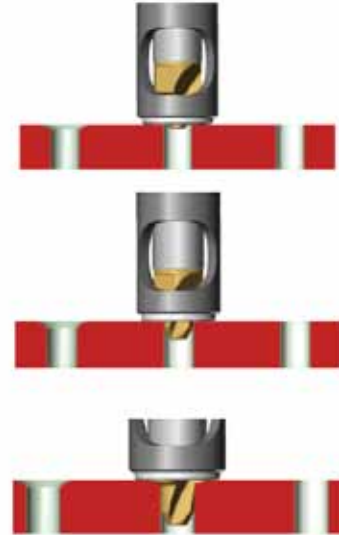

Study Details



TOOL
COMP V2 Tool

PRODUCTION
40,000 a month

PART
Housing with 4 hole bolt pattern

MATERIAL
Cast Aluminum

HOLE SIZE
Ø7.6mm

COUNTERSINK
0.30 ± 0.12mm x 72.5° ± 2°

Speed 500 RPM
Feed .007 IPR

REPLACING
Replaced solid carbide countersink which could not hold countersink tolerance due to 0.3 casting variation

PRODUCT SECTION → PG. CALL

Meeting aerospace customers' further need for accuracy and non-rotational end effectors that cannot mark super critical finishes, the COMP tool was born. The HEULE COMP highlights the true meaning of swiss engineering and innovation by meeting the challenges of manufacturing state of the art tooling that can hold up in high demand production facilities.

"We've had the tool in production with no problems... our scrap rate went from approx. 400 pcs a month to less than one due to chamfer issues..."

There are three different versions:
V1: Allowed simple insertable inserts to front countersink or radius drill holes where the surface of the part varied
V2: Allowed the cage to contact the part first avoiding chip interference. The double compression action allowed for drilling and countersinking with a carbide drill
V3: Offers fine adjustment to the chamfer depth of .0008" (0.02MM), a longer drill depth of up to 3xd, and non-rotating end effector.



Visit our website for our full line
of product brochures and videos

www.HeuleTool.com

We provide online tool selectors for the
COFA, **SNAP**, **DEFA** and **BSF** product groups.

Simply enter your application information and the correct tool will
be provided complete with order number and sample drawing.

We are also available on:



A large grid area for taking notes, consisting of approximately 30 columns and 30 rows of small squares. At the bottom center of the grid, there is a faint watermark logo consisting of a square with a white cross inside, and the text "SWISS MADE" in a large, bold, sans-serif font.

COFA

Deburring Tool for Elliptical or Contoured Surfaces

- Replaceable solid carbide coated blades
- Blade coatings offer longer tool life and increased performance
- Sizes 2-41mm (.079-1.614") available from stock
- Breakthrough technology provides consistent quality

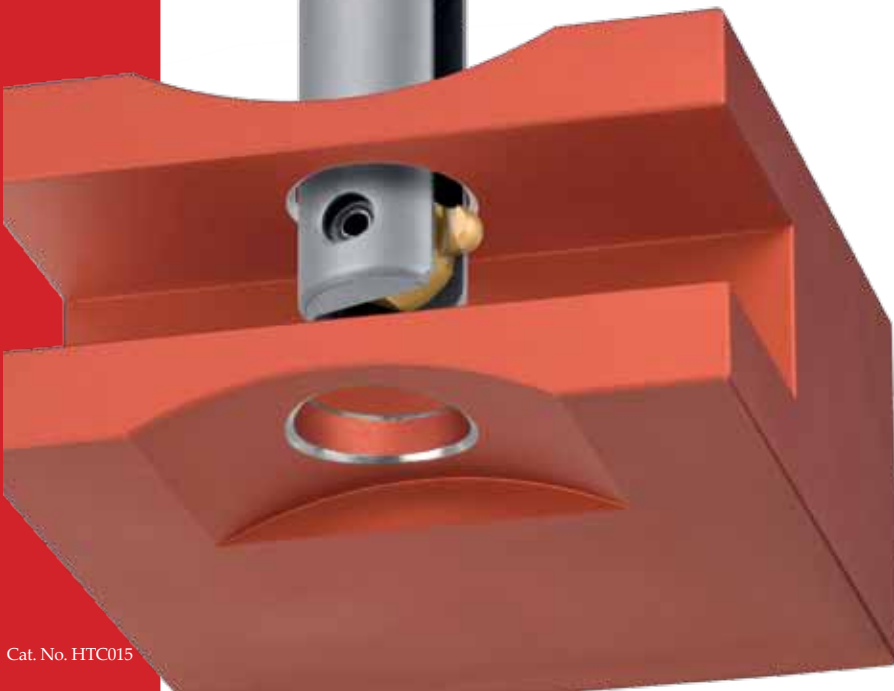

The HEULE COFA deburring tool removes burrs from the front and back of a drilled through hole without stopping or reversing the spindle. Whether you are deburring a flat surface or an irregular surface, the edge break is always even and consistent.

Deburr Elliptical Holes

The COFA tool will deburr the contours of an elliptical hole when two holes intersect or a hole is not perpendicular to the surface. The COFA with a standard blade can be used when the larger intersecting hole is two or more times the smaller or for surfaces up to 15°. Deburr more extreme contours by using a 30° blade with extra clearance relief.

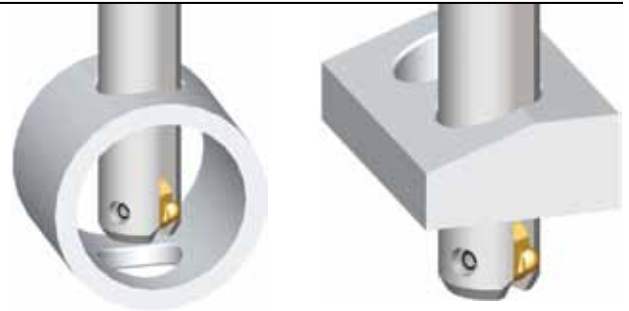

Radiused Edge Breaks on Flat Parts

Deburr the front and back of any through hole with a smooth tapered edge break to relieve stress points and sharp corners. Use the blade with 10° clearance relief for better tool life when deburring flat parts.

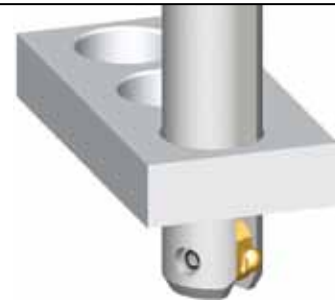

Wide Range of Tools

COFA tools are available from stock for immediate delivery in sizes 2mm-41mm (.079"-1.614"). The COFA Cassette is also in stock for deburring even larger holes quickly and efficiently.



How Does It Work?

Controlled by a simple spring, the carbide cutting blade follows the contour of the hole's surface removing all burrs while creating an even tapered corner break. The blade does not cut as it passes through the bore and will not damage the hole's surface.

The edge break begins only at the point where the blade makes contact with the material and then tapers the hole's edge. This allows for faster feed rates since the tool slows itself down as it enters the through hole.

The simple concept of the COFA tool has no adjusting screws or presetting requirements. Only a choice of common tool sizes and spring strengths for various materials and hole sizes.



COFA blade geometry cutting uneven surface.

Typical Parts



How to Order:

Ordering is simple. The COFA tool provides different blade and spring options to create the most effective tool for any application depending on the hole geometry and type of material being machined.

1. Choose the tool that best fits the hole diameter.
2. Choose the blade that best fits the hole geometry.
3. Choose the spring that best fits the material.

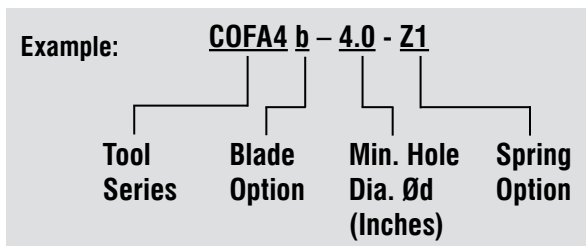

HTC015

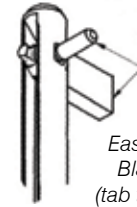
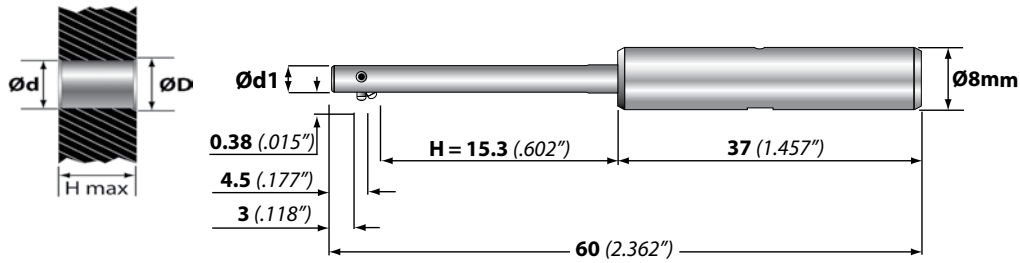

Easy to change
Blade and pin
(tab that snaps off)

COFA Deburring Series 2

Ød Min. Hole mm inches	ØD1 Tool Diameter +0/- .03 mm inches	ØD Approx. Cutting Diameter mm inches	Complete Tool with Blade	
			Front and Back Order Number	Back Only Order Number
2.0 .079	1.95 .077	2.3 .091	COFA2-2.0- <input type="checkbox"/>	COFA2b-2.0- <input type="checkbox"/>
2.1 .083	2.05 .081	2.4 .095	COFA2-2.1- <input type="checkbox"/>	COFA2b-2.1- <input type="checkbox"/>
2.3 .091	2.25 .089	2.6 .102	COFA2-2.3- <input type="checkbox"/>	COFA2b-2.3- <input type="checkbox"/>
2.5 .099	2.45 .096	2.8 .110	COFA2-2.5- <input type="checkbox"/>	COFA2b-2.5- <input type="checkbox"/>
2.7 .106	2.65 .104	3.0 .118	COFA2-2.7- <input type="checkbox"/>	COFA2b-2.7- <input type="checkbox"/>
2.9 .114	2.85 .112	3.2 .126	COFA2-2.9- <input type="checkbox"/>	COFA2b-2.9- <input type="checkbox"/>
3.0 .118	2.95 .116	3.3 .130	COFA2-3.0- <input type="checkbox"/>	COFA2b-3.0- <input type="checkbox"/>
3.1 .122	3.05 .120	3.4 .134	COFA2-3.1- <input type="checkbox"/>	COFA2b-3.1- <input type="checkbox"/>

Spring Choice: W, H, S, Z

BLADE
OPTIONS **PG. 53**

SPARE
PARTS **PG. 27**

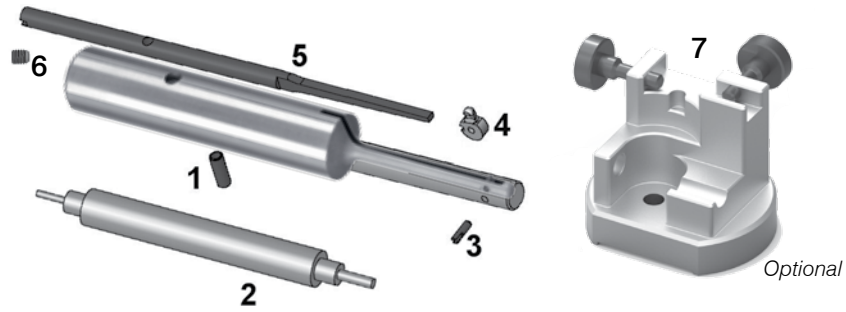

Spare Parts – COFA 2

1	2	3	4	5	6	7
Retainer Pin	Assembly Pin	Split Pin	Blade	Spring	Set Screw	Wrench
GH-H-S-1017	C2-V-0001	C2-E-0002	See Below	See Below	GH-H-S-0135	GH-H-S-2106
						C3-V-0002

Spring Options:

The cutting force of the COFA tool is controlled by a flat spring. Choose the proper spring for the material being machined.

Spring Code	Order Number	Typical Materials
W	C2-E-0013	Aluminum, Brass, Magnesium
H	C2-E-0014	Grey Cast Iron, Nodular Iron
S	C2-E-0015	Carbon Steel, Free Machining Steel
Z*	C2-E-0016	Nickel, Titanium, Stainless

Large or Heavy Burrs may require a stronger spring

Softer
↑
↓
Harder

* Not recommended with COFA2-2.0 tool.

Blade Options:

Blades are available from stock as front and back cutting (**fab**) or back cutting only (**bco**).

Blade Code	Blade Type	Geo.	Series 2
	TiALN 20° Standard	fab	C2-M-0006-A
b		bco	C2-M-0016-A
y	TiALN 10°	fab	C2-M-0007-A
yb		bco	C2-M-0017-A

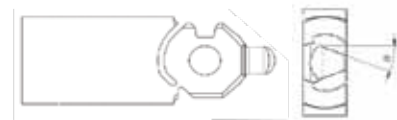

How to Order:

Ordering is simple. The COFA tool provides different blade and spring options to create the most effective tool for any application depending on the hole geometry and type of material being machined.

1. Choose the tool that best fits the hole diameter.
2. Choose the blade that best fits the hole geometry.
3. Choose the spring that best fits the material.

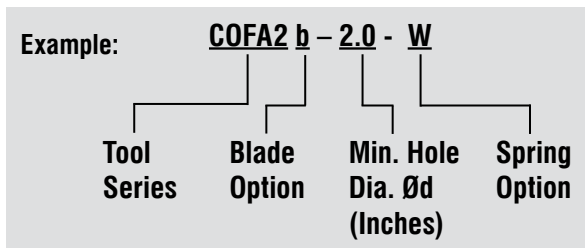

PROGRAMMING PG. 46-47

CHANGE BLADES PG. 48-51

HTC015

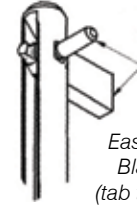
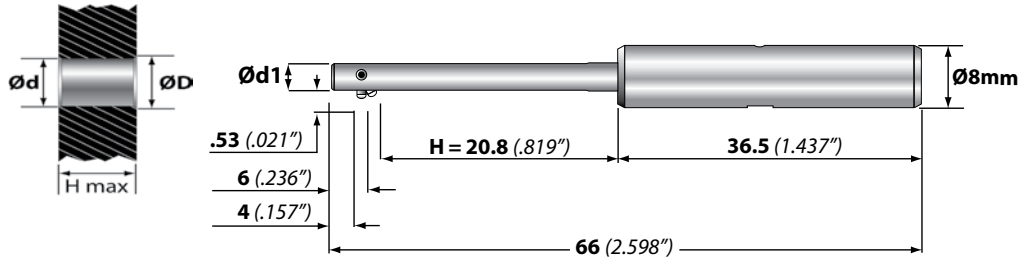

Easy to change
Blade and pin
(tab that snaps off)

COFA Deburring Series 3

Ød Min. Hole mm inches	Ød1 Tool Diameter +0/- .03 mm inches	ØD Approx. Cutting Diameter mm inches	Complete Tool with Blade	
			Front and Back Order Number	Back Only Order Number
3.0 .118	2.95 .116	3.4 .134	COFA3-3.0- <input type="checkbox"/>	COFA3b-3.0- <input type="checkbox"/>
3.1 .122	3.05 .120	3.5 .138	COFA3-3.1- <input type="checkbox"/>	COFA3b-3.1- <input type="checkbox"/>
3.3 .130	3.25 .128	3.7 .146	COFA3-3.3- <input type="checkbox"/>	COFA3b-3.3- <input type="checkbox"/>
3.5 .138	3.45 .136	3.9 .154	COFA3-3.5- <input type="checkbox"/>	COFA3b-3.5- <input type="checkbox"/>
3.7 .146	3.65 .144	4.1 .161	COFA3-3.7- <input type="checkbox"/>	COFA3b-3.7- <input type="checkbox"/>
3.9 .154	3.85 .152	4.3 .169	COFA3-3.9- <input type="checkbox"/>	COFA3b-3.9- <input type="checkbox"/>
4.0 .158	3.95 .156	4.4 .173	COFA3-4.0- <input type="checkbox"/>	COFA3b-4.0- <input type="checkbox"/>
4.1 .161	4.05 .159	4.5 .177	COFA3-4.1- <input type="checkbox"/>	COFA3b-4.1- <input type="checkbox"/>

Spring Choice: W, H, S, Z

BLADE
OPTIONS **PG. 53**

SPARE
PARTS **PG. 29**

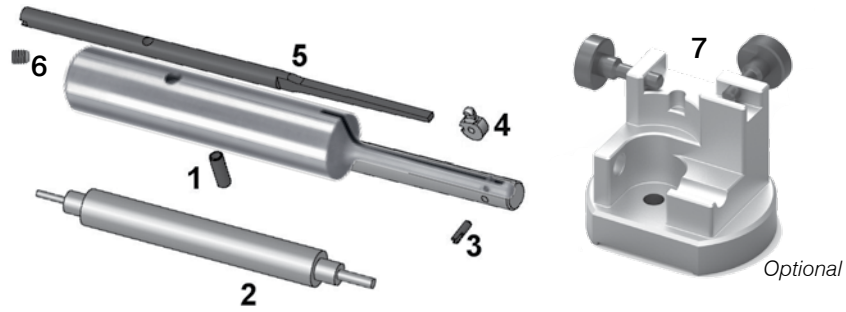

Spare Parts – COFA 3

1	2	3	4	5	6	7
Retainer Pin	Assembly Pin	Split Pin	Blade	Spring	Set Screw	Wrench
GH-H-S-1017	C3-V-0001	C3-E-0002	See Below	See Below	GH-H-S-0135	GH-H-S-2106
						C3-V-0002

Spring Options:

The cutting force of the COFA tool is controlled by a flat spring. Choose the proper spring for the material being machined.

Spring Code	Order Number	Typical Materials
W	C3-E-0013	Aluminum, Brass, Magnesium
H	C3-E-0014	Grey Cast Iron, Nodular Iron
S	C3-E-0015	Carbon Steel, Free Machining Steel
Z	C3-E-0016	Nickel, Titanium, Stainless

Large or Heavy Burrs may require a stronger spring

Softer
↑
↓
Harder

Blade Options:

Blades are available from stock as front and back cutting (**fab**) or back cutting only (**bco**).

Blade Code	Blade Type	Geo.	Series 3
	TiALN 20° Standard	fab	C3-M-0006-A
b		bco	C3-M-0016-A
y	TiALN 10°	fab	C3-M-0007-A
yb		bco	C3-M-0017-A



How to Order:

Ordering is simple. The COFA tool provides different blade and spring options to create the most effective tool for any application depending on the hole geometry and type of material being machined.

1. Choose the tool that best fits the hole diameter.
2. Choose the blade that best fits the hole geometry.
3. Choose the spring that best fits the material.

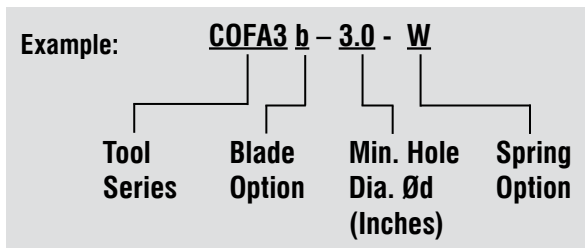

PROGRAMMING PG. 46-47

CHANGE BLADES PG. 48-51

HTC015

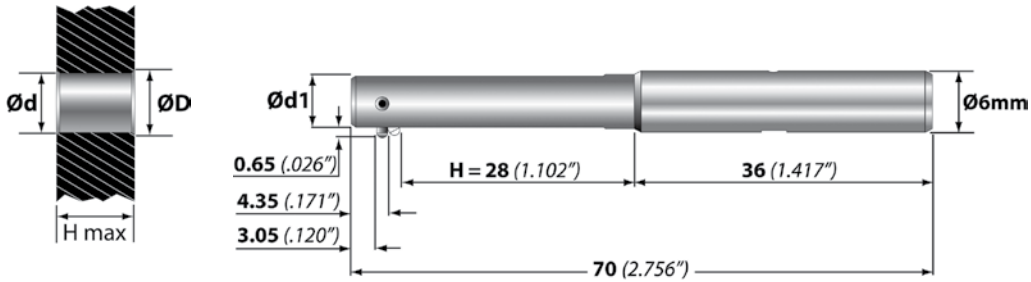

COFA Deburring Series 4

Ød Min. Hole mm inches	Ød1 Tool Dia. mm inches	ØD Approx. Cutting Dia. mm inches	Complete Tool with Blade	
			Front and Back Order Number	Back Only Order Number
4.0 .157	3.9 .154	4.5 .177	COFA4-4.0- <input type="checkbox"/>	COFA4b-4.0- <input type="checkbox"/>
4.1 .161	4.0 .157	4.6 .181	COFA4-4.1- <input type="checkbox"/>	COFA4b-4.1- <input type="checkbox"/>
4.2 .165	4.1 .161	4.7 .185	COFA4-4.2- <input type="checkbox"/>	COFA4b-4.2- <input type="checkbox"/>
4.3 .169	4.2 .165	4.8 .189	COFA4-4.3- <input type="checkbox"/>	COFA4b-4.3- <input type="checkbox"/>
4.4 .173	4.3 .169	4.9 .193	COFA4-4.4- <input type="checkbox"/>	COFA4b-4.4- <input type="checkbox"/>
4.5 .177	4.4 .173	5.0 .197	COFA4-4.5- <input type="checkbox"/>	COFA4b-4.5- <input type="checkbox"/>
4.6 .181	4.5 .177	5.1 .201	COFA4-4.6- <input type="checkbox"/>	COFA4b-4.6- <input type="checkbox"/>
4.7 .185	4.6 .181	5.2 .205	COFA4-4.7- <input type="checkbox"/>	COFA4b-4.7- <input type="checkbox"/>
4.8 .189	4.7 .185	5.3 .209	COFA4-4.8- <input type="checkbox"/>	COFA4b-4.8- <input type="checkbox"/>
4.9 .193	4.8 .189	5.4 .213	COFA4-4.9- <input type="checkbox"/>	COFA4b-4.9- <input type="checkbox"/>

Spring Choice: W, H, S, Z, Z1

BLADE
OPTIONS PG. 53

SPARE
PARTS PG. 31

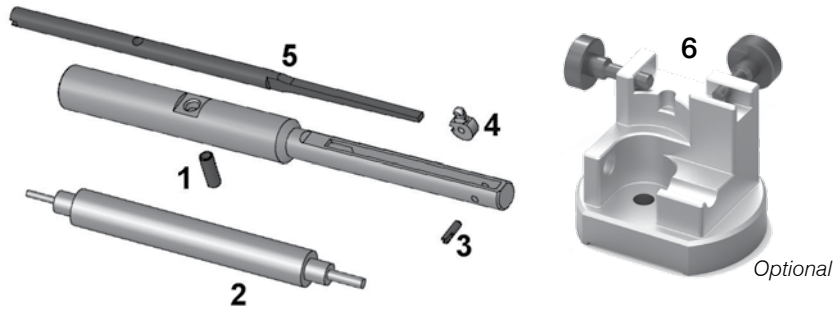

Spare Parts – COFA 4

1	2	3	4	5	6
Retainer Pin	Assembly Pin	Split Pin	Blade	Spring	Fixture
GH-H-S-0902	GH-C-V-0206	GH-C-E-0819	See Below	See Below	GH-C-V-0541

Spring Options:

The cutting force of the COFA tool is controlled by a flat spring. Choose the proper spring for the material being machined.

Spring Code	Order Number	Typical Materials
W	GH-C-E-0342	Aluminum, Brass, Magnesium
H	GH-C-E-0343	Grey Cast Iron, Nodular Iron
S	GH-C-E-0344	Carbon Steel, Free Machining Steel
Z	GH-C-E-0345	Long Chipping Steel, Stainless
Z1	GH-C-E-0346	Titanium, Hardened Steel, Nickel Alloy

Large or Heavy Burrs may require a stronger spring

Softer ↑
↓ Harder

Blade Options:

Blades are available from stock as front and back cutting (**fab**) or back cutting only (**bco**).

Blade Code	Blade Type	Geo.	Series 4
b	TiALN 20° Standard	fab	GH-C-M-0504
		bco	GH-C-M-0914
y	TiALN 10° Flat Surfaces	fab	GH-C-M-0764
yb		bco	GH-C-M-0874
x	TiALN 30° Uneven Spec	fab	GH-C-M-0148
xb		bco	GH-C-M-0182

How to Order:

Ordering is simple. The COFA tool provides different blade and spring options to create the most effective tool for any application depending on the hole geometry and type of material being machined.

1. Choose the tool that best fits the hole diameter.
2. Choose the blade that best fits the hole geometry.
3. Choose the spring that best fits the material.

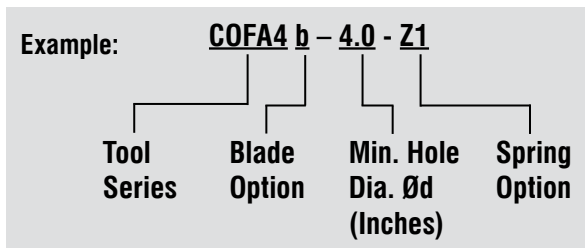

PROGRAMMING PG. 46-47

CHANGE BLADES PG. 48-51

HTC015

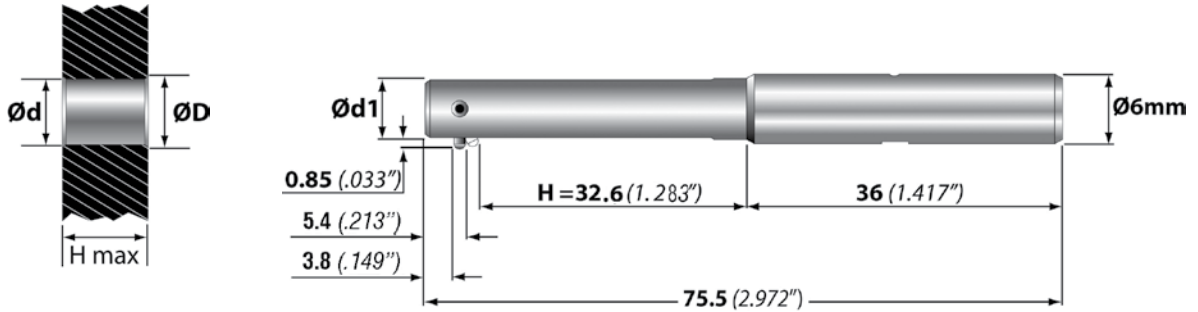

COFA Deburring Series 5

Ød	Ød1	ØD	Complete Tool with Blade	
Min. Hole mm inches	Tool Dia. mm inches	Approx. Cutting Dia. mm inches	Front and Back Order Number	Back Only Order Number
5.0 .197	4.9 .193	5.7 .224	COFA5-5.0- <input type="checkbox"/>	COFA5b-5.0- <input type="checkbox"/>
5.1 .201	5.0 .197	5.8 .228	COFA5-5.1- <input type="checkbox"/>	COFA5b-5.1- <input type="checkbox"/>
5.2 .205	5.1 .201	5.9 .232	COFA5-5.2- <input type="checkbox"/>	COFA5b-5.2- <input type="checkbox"/>
5.3 .209	5.2 .205	6.0 .236	COFA5-5.3- <input type="checkbox"/>	COFA5b-5.3- <input type="checkbox"/>
5.4 .213	5.3 .209	6.1 .240	COFA5-5.4- <input type="checkbox"/>	COFA5b-5.4- <input type="checkbox"/>
5.5 .217	5.4 .213	6.2 .244	COFA5-5.5- <input type="checkbox"/>	COFA5b-5.5- <input type="checkbox"/>
5.6 .220	5.5 .217	6.3 .248	COFA5-5.6- <input type="checkbox"/>	COFA5b-5.6- <input type="checkbox"/>
5.7 .224	5.6 .220	6.4 .252	COFA5-5.7- <input type="checkbox"/>	COFA5b-5.7- <input type="checkbox"/>
5.8 .228	5.7 .224	6.5 .256	COFA5-5.8- <input type="checkbox"/>	COFA5b-5.8- <input type="checkbox"/>
5.9 .232	5.8 .228	6.6 .260	COFA5-5.9- <input type="checkbox"/>	COFA5b-5.9- <input type="checkbox"/>

Spring Choice: W, H, S, Z, Z1

BLADE
OPTIONS **PG. 53**

SPARE
PARTS **PG. 33**

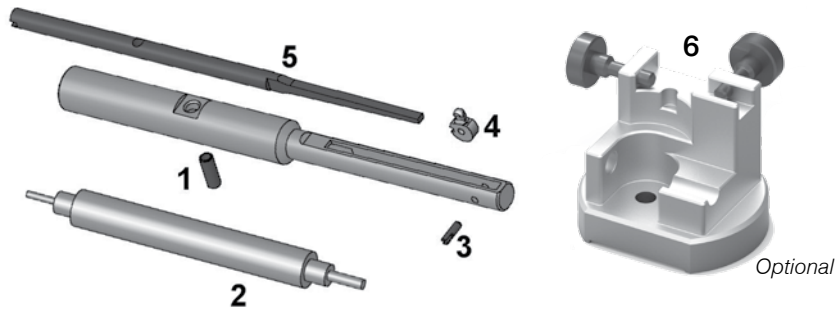

Spare Parts – COFA 5

1	2	3	4	5	6
Retainer Pin	Assembly Pin	Split Pin	Blade	Spring	Fixture
GH-H-S-0902	GH-C-V-0211	GH-C-E-0820	See Below	See Below	GH-C-V-0541

Spring Options:

The cutting force of the COFA tool is controlled by a flat spring. Choose the proper spring for the material being machined.

Spring Code	Order Number	Typical Materials <i>Large or Heavy Burrs may require a stronger spring</i>	
W	GH-C-E-0352	Softer ↑ ↓ Harder	Aluminum, Brass, Magnesium
H	GH-C-E-0353		Grey Cast Iron, Nodular Iron
S	GH-C-E-0354		Carbon Steel, Free Machining Steel
Z	GH-C-E-0355		Long Chipping Steel, Stainless
Z1	GH-C-E-0356		Titanium, Hardened Steel, Nickel Alloy

Blade Options:

Blades are available from stock as front and back cutting (fab) or back cutting only (bco).

Blade Code	Blade Type	Geo.	Series 5
	TiALN 20° Standard	fab	GH-C-M-0505
b		bco	GH-C-M-0915
y	TiALN 10° Flat Surfaces	fab	GH-C-M-0765
yb		bco	GH-C-M-0875
x	TiALN 30° Uneven Spec	fab	GH-C-M-0150
xb		bco	GH-C-M-0184

How to Order:

Ordering is simple. The COFA tool provides different blade and spring options to create the most effective tool for any application depending on the hole geometry and type of material being machined.

1. Choose the tool that best fits the hole diameter.
2. Choose the blade that best fits the hole geometry.
3. Choose the spring that best fits the material.

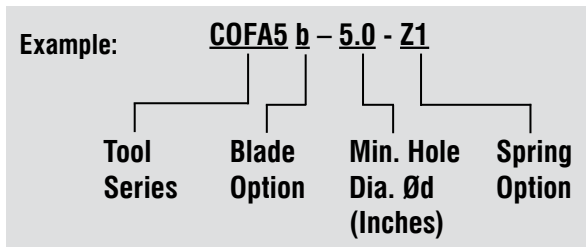

PROGRAMMING PG. 46-47

CHANGE BLADES PG. 48-51

HTC015

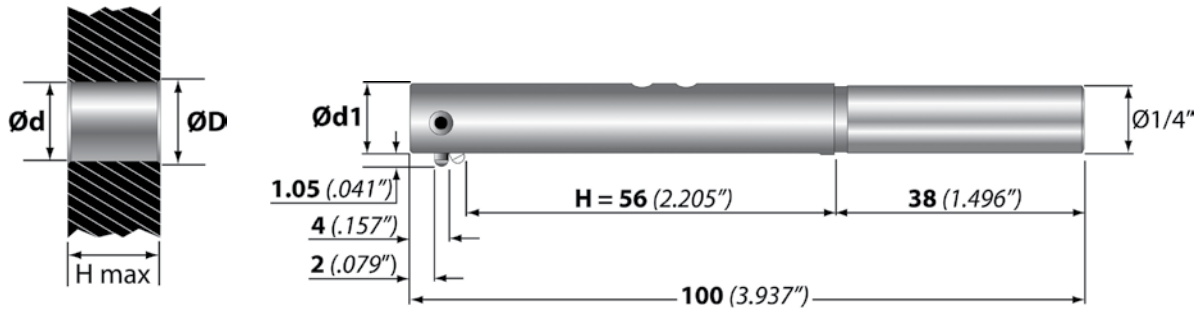

COFA Deburring Series 6

$\varnothing d$	$\varnothing d1$	$\varnothing D$	Complete Tool with Blade	
Min. Hole mm inches	Tool Dia. mm inches	Approx. Cutting Dia. mm inches	Front and Back Order Number	Back Only Order Number
6.0 .236	5.8 .228	6.7 .264	COFA6-236-□	COFA6b-236-□
6.2 .244	6.0 .236	6.9 .272	COFA6-244-□	COFA6b-244-□
6.4 .252	6.2 .244	7.1 .279	COFA6-252-□	COFA6b-252-□
6.6 .260	6.4 .252	7.3 .287	COFA6-260-□	COFA6b-260-□
6.8 .268	6.6 .260	7.5 .295	COFA6-268-□	COFA6b-268-□
7.0 .276	6.8 .268	7.7 .303	COFA6-276-□	COFA6b-276-□
7.2 .284	7.0 .276	7.9 .311	COFA6-284-□	COFA6b-284-□
7.4 .291	7.2 .283	8.1 .319	COFA6-291-□	COFA6b-291-□
7.6 .299	7.4 .291	8.3 .327	COFA6-299-□	COFA6b-299-□
7.8 .307	7.6 .299	8.5 .335	COFA6-307-□	COFA6b-307-□
8.0 .315	7.8 .307	8.7 .342	COFA6-315-□	COFA6b-315-□

Spring Choice: W, H, S, Z, Z1, Z2, Z3

BLADE
OPTIONS **PG. 53**

SPARE
PARTS **PG. 35**

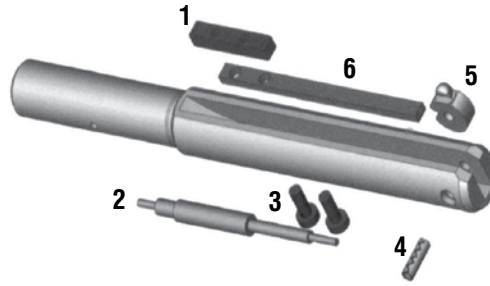

Spare Parts – COFA 6

1	2	3	4	5	6
Retainer Block	Assembly Pin	Screw	Roll Pin	Blade	Spring
GH-C-E-0812	GH-C-V-0126	GH-H-S-0803	GH-C-E-0811	See Below	See Below

Spring Options:

The cutting force of the COFA tool is controlled by a flat spring. Choose the proper spring for the material being machined.

Spring Code	Order Number	Typical Materials <i>Large or Heavy Burrs may require a stronger spring</i>
W	GH-C-E-0321	Aluminum, Brass, Magnesium
H	GH-C-E-0322	Grey Cast Iron, Nodular Iron
S	GH-C-E-0323	Carbon Steel, Free Machining Steel
Z	GH-C-E-0324	Long Chipping Steel, Stainless
Z1	GH-C-E-0325	Titanium, Hardened Steel, Nickel Alloy
Z2	GH-C-E-0326	Nickel Alloy, etc
Z3	GH-C-E-0327	Nickel Alloy, etc

Softer
↑
↓
Harder

Blade Options:

Blades are available from stock as front and back cutting (fab) or back cutting only (bco).

Blade Code	Blade Type	Geo.	Series 6
	TiALN 20° Standard	fab	GH-C-M-0002
b		bco	GH-C-M-0012
y	TiALN 10° Flat Surfaces	fab	GH-C-M-0462
yb		bco	GH-C-M-0472
x	TiALN 30° Uneven Spec	fab	GH-C-M-0142
xb		bco	GH-C-M-0143

How to Order:

Ordering is simple. The COFA tool provides different blade and spring options to create the most effective tool for any application depending on the hole geometry and type of material being machined.

1. Choose the tool that best fits the hole diameter.
2. Choose the blade that best fits the hole geometry.
3. Choose the spring that best fits the material.

Example:

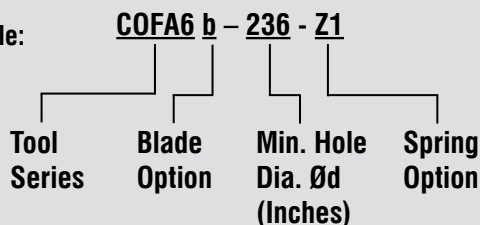

PROGRAMMING PG. 46-47

CHANGE BLADES PG. 48-51

HTC015

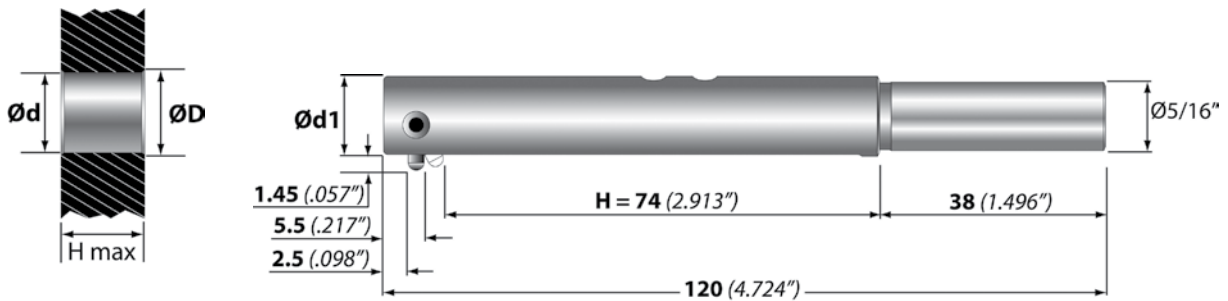

COFA Deburring Series 8

$\varnothing d$	$\varnothing d1$	$\varnothing D$	Complete Tool with Blade	
Min. Hole mm inches	Tool Dia. mm inches	Approx. Cutting Dia. mm inches	Front and Back Order Number	Back Only Order Number
8.0 .315	7.8 .307	9.0 .354	COFA8-315- <input type="checkbox"/>	COFA8b-315- <input type="checkbox"/>
8.2 .323	8.0 .315	9.2 .362	COFA8-323- <input type="checkbox"/>	COFA8b-323- <input type="checkbox"/>
8.4 .331	8.2 .323	9.4 .370	COFA8-331- <input type="checkbox"/>	COFA8b-331- <input type="checkbox"/>
8.6 .339	8.4 .331	9.6 .378	COFA8-339- <input type="checkbox"/>	COFA8b-339- <input type="checkbox"/>
8.8 .346	8.6 .339	9.8 .386	COFA8-346- <input type="checkbox"/>	COFA8b-346- <input type="checkbox"/>
9.0 .354	8.8 .346	10.0 .394	COFA8-354- <input type="checkbox"/>	COFA8b-354- <input type="checkbox"/>
9.2 .362	9.0 .354	10.2 .402	COFA8-362- <input type="checkbox"/>	COFA8b-362- <input type="checkbox"/>
9.4 .370	9.2 .362	10.4 .409	COFA8-370- <input type="checkbox"/>	COFA8b-370- <input type="checkbox"/>
9.6 .378	9.4 .370	10.6 .417	COFA8-378- <input type="checkbox"/>	COFA8b-378- <input type="checkbox"/>
9.8 .386	9.6 .378	10.8 .425	COFA8-386- <input type="checkbox"/>	COFA8b-386- <input type="checkbox"/>
10.0 .394	9.8 .386	11.0 .433	COFA8-394- <input type="checkbox"/>	COFA8b-394- <input type="checkbox"/>
10.2 .402	10.0 .394	11.2 .441	COFA8-402- <input type="checkbox"/>	COFA8b-402- <input type="checkbox"/>
10.4 .409	10.2 .402	11.4 .449	COFA8-409- <input type="checkbox"/>	COFA8b-409- <input type="checkbox"/>
10.6 .417	10.4 .409	11.6 .457	COFA8-417- <input type="checkbox"/>	COFA8b-417- <input type="checkbox"/>
10.8 .425	10.6 .417	11.8 .465	COFA8-425- <input type="checkbox"/>	COFA8b-425- <input type="checkbox"/>
11.0 .433	10.8 .425	12.0 .473	COFA8-433- <input type="checkbox"/>	COFA8b-433- <input type="checkbox"/>
11.2 .441	11.0 .433	12.2 .480	COFA8-441- <input type="checkbox"/>	COFA8b-441- <input type="checkbox"/>
11.4 .449	11.2 .441	12.4 .488	COFA8-449- <input type="checkbox"/>	COFA8b-449- <input type="checkbox"/>
11.6 .457	11.4 .449	12.6 .496	COFA8-457- <input type="checkbox"/>	COFA8b-457- <input type="checkbox"/>
11.8 .465	11.6 .457	12.8 .504	COFA8-465- <input type="checkbox"/>	COFA8b-465- <input type="checkbox"/>
12.0 .473	11.8 .465	13.0 .512	COFA8-473- <input type="checkbox"/>	COFA8b-473- <input type="checkbox"/>
12.2 .480	12.0 .473	13.2 .520	COFA8-480- <input type="checkbox"/>	COFA8b-480- <input type="checkbox"/>

Spring Choice: W, H, S, Z, Z1, Z2, Z3

BLADE
OPTIONS PG. 53

SPARE
PARTS PG. 37

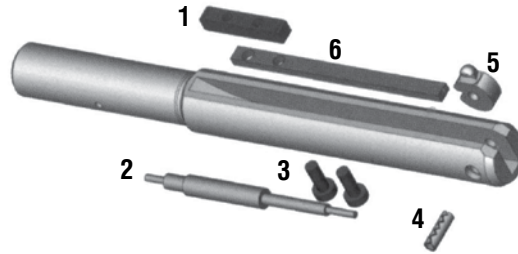

Spare Parts – COFA 8

1	2	3	4	5	6
Retainer Block	Assembly Pin	Screw	Roll Pin	Blade	Spring
GH-C-E-0808	GH-C-V-0111	GH-H-S-0517	GH-C-E-0810	See Below	See Below

Spring Options:

The cutting force of the COFA tool is controlled by a flat spring. Choose the proper spring for the material being machined.

Spring Code	Order Number	Typical Materials <i>Large or Heavy Burrs may require a stronger spring</i>	
W	GH-C-E-0331	Softer ↑ ↓ Harder	Aluminum, Brass, Magnesium
H	GH-C-E-0332		Grey Cast Iron, Nodular Iron
S	GH-C-E-0333		Carbon Steel, Free Machining Steel
Z	GH-C-E-0334		Long Chipping Steel, Stainless
Z1	GH-C-E-0335		Titanium, Hardened Steel, Nickel Alloy
Z2	GH-C-E-0336		Nickel Alloy, etc
Z3	GH-C-E-0337		Nickel Alloy, etc

Blade Options:

Blades are available from stock as front and back cutting (fab) or back cutting only (bco).

Blade Code	Blade Type	Geo.	Series 8
	TiALN 20° Standard	fab	GH-C-M-0003
b		bco	GH-C-M-0013
y	TiALN 10° Flat Surfaces	fab	GH-C-M-0463
yb		bco	GH-C-M-0473
x	TiALN 30° Uneven Spec	fab	GH-C-M-0133
xb		bco	GH-C-M-0131

How to Order:

Ordering is simple. The COFA tool provides different blade and spring options to create the most effective tool for any application depending on the hole geometry and type of material being machined.

1. Choose the tool that best fits the hole diameter.
2. Choose the blade that best fits the hole geometry.
3. Choose the spring that best fits the material.

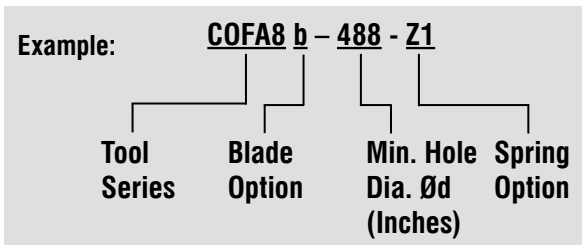

PROGRAMMING	PG. 46-47
CHANGE BLADES	PG. 48-51

HTC015

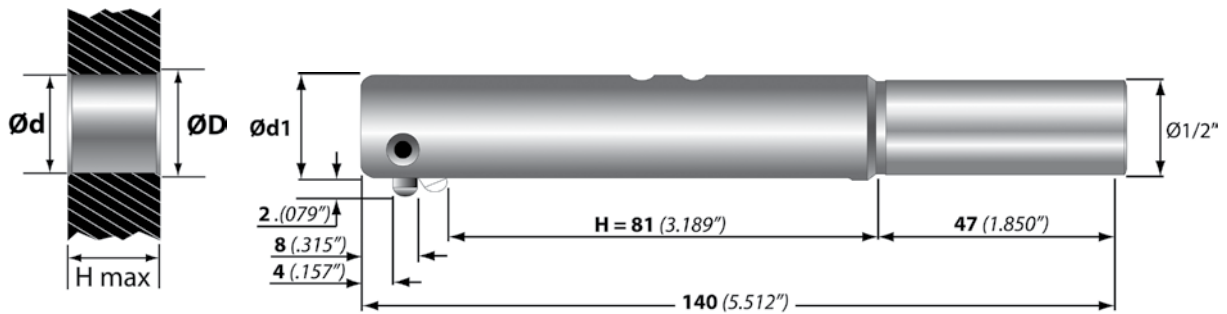

COFA Deburring Series 12

Ød Min. Hole mm inches	Ød1 Tool Dia. mm inches	ØD Approx. Cutting Dia. mm inches	Complete Tool with Blade	
			Front and Back Order Number	Back Only Order Number
12.4 .488	12.2 .480	13.8 .543	COFA12-488- <input type="checkbox"/>	COFA12b-488- <input type="checkbox"/>
12.8 .504	12.6 .496	14.2 .559	COFA12-504- <input type="checkbox"/>	COFA12b-504- <input type="checkbox"/>
13.2 .520	13.0 .512	14.6 .575	COFA12-520- <input type="checkbox"/>	COFA12b-520- <input type="checkbox"/>
13.6 .536	13.4 .528	15.0 .591	COFA12-536- <input type="checkbox"/>	COFA12b-536- <input type="checkbox"/>
14.0 .551	13.8 .543	15.4 .606	COFA12-551- <input type="checkbox"/>	COFA12b-551- <input type="checkbox"/>
14.4 .567	14.2 .559	15.8 .622	COFA12-567- <input type="checkbox"/>	COFA12b-567- <input type="checkbox"/>
14.8 .583	14.6 .575	16.2 .638	COFA12-583- <input type="checkbox"/>	COFA12b-583- <input type="checkbox"/>
15.2 .599	15.0 .591	16.6 .654	COFA12-599- <input type="checkbox"/>	COFA12b-599- <input type="checkbox"/>
15.6 .614	15.4 .606	17.0 .669	COFA12-614- <input type="checkbox"/>	COFA12b-614- <input type="checkbox"/>
16.0 .630	15.8 .622	17.4 .685	COFA12-630- <input type="checkbox"/>	COFA12b-630- <input type="checkbox"/>
16.4 .646	16.2 .638	17.8 .701	COFA12-646- <input type="checkbox"/>	COFA12b-646- <input type="checkbox"/>
16.8 .662	16.6 .654	18.2 .717	COFA12-662- <input type="checkbox"/>	COFA12b-662- <input type="checkbox"/>
17.2 .677	17.0 .669	18.6 .732	COFA12-677- <input type="checkbox"/>	COFA12b-677- <input type="checkbox"/>
17.6 .693	17.4 .685	19.0 .748	COFA12-693- <input type="checkbox"/>	COFA12b-693- <input type="checkbox"/>
18.0 .709	17.8 .701	19.4 .764	COFA12-709- <input type="checkbox"/>	COFA12b-709- <input type="checkbox"/>
18.4 .725	18.2 .717	19.8 .780	COFA12-725- <input type="checkbox"/>	COFA12b-725- <input type="checkbox"/>
18.8 .740	18.6 .732	20.2 .795	COFA12-740- <input type="checkbox"/>	COFA12b-740- <input type="checkbox"/>
19.2 .756	19.0 .748	20.6 .811	COFA12-756- <input type="checkbox"/>	COFA12b-756- <input type="checkbox"/>
19.6 .772	19.4 .764	21.0 .827	COFA12-772- <input type="checkbox"/>	COFA12b-772- <input type="checkbox"/>
20.0 .788	19.8 .780	21.4 .843	COFA12-788- <input type="checkbox"/>	COFA12b-788- <input type="checkbox"/>

Spring Choice: W, H, S, Z, Z1, Z2, Z3

BLADE
OPTIONS **PG. 53**

SPARE
PARTS **PG. 39**

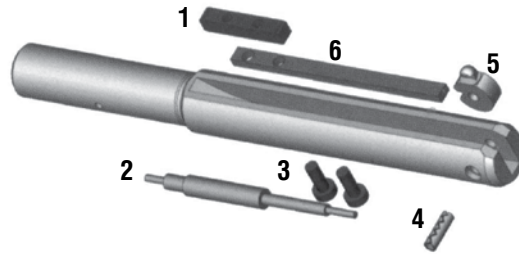

Spare Parts – COFA 12

1	2	3	4	5	6
Retainer Block	Assembly Pin	Screw	Roll Pin	Blade	Spring
GH-C-E-0800	GH-C-V-0100	GH-H-S-0530	GH-C-E-0801	See Below	See Below

Spring Options:

The cutting force of the COFA tool is controlled by a flat spring. Choose the proper spring for the material being machined.

Spring Code	Order Number	Typical Materials
W	GH-C-E-0361	Aluminum, Brass, Magnesium
H	GH-C-E-0362	Grey Cast Iron, Nodular Iron
S	GH-C-E-0363	Carbon Steel, Free Machining Steel
Z	GH-C-E-0364	Long Chipping Steel, Stainless
Z1	GH-C-E-0365	Titanium, Hardened Steel, Nickel Alloy
Z2	GH-C-E-0366	Nickel Alloy, etc
Z3	GH-C-E-0367	Nickel Alloy, etc

Large or Heavy Burrs may require a stronger spring

Softer

↑

Harder

Blade Options:

Blades are available from stock as front and back cutting (fab) or back cutting only (bco).

Blade Code	Blade Type	Geo.	Series 12
b	TiALN 20° Standard	fab	GH-C-M-0007
		bco	GH-C-M-0017
yb	TiALN 10° Flat Surfaces	fab	GH-C-M-0467
		bco	GH-C-M-0477
xb	TiALN 30° Uneven Spec	fab	GH-C-M-0105
		bco	GH-C-M-0104

How to Order:

Ordering is simple. The COFA tool provides different blade and spring options to create the most effective tool for any application depending on the hole geometry and type of material being machined.

1. Choose the tool that best fits the hole diameter.
2. Choose the blade that best fits the hole geometry.
3. Choose the spring that best fits the material.

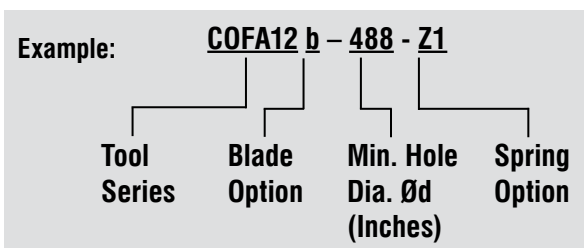

PROGRAMMING PG. 46-47

CHANGE BLADES PG. 48-51

HTC015

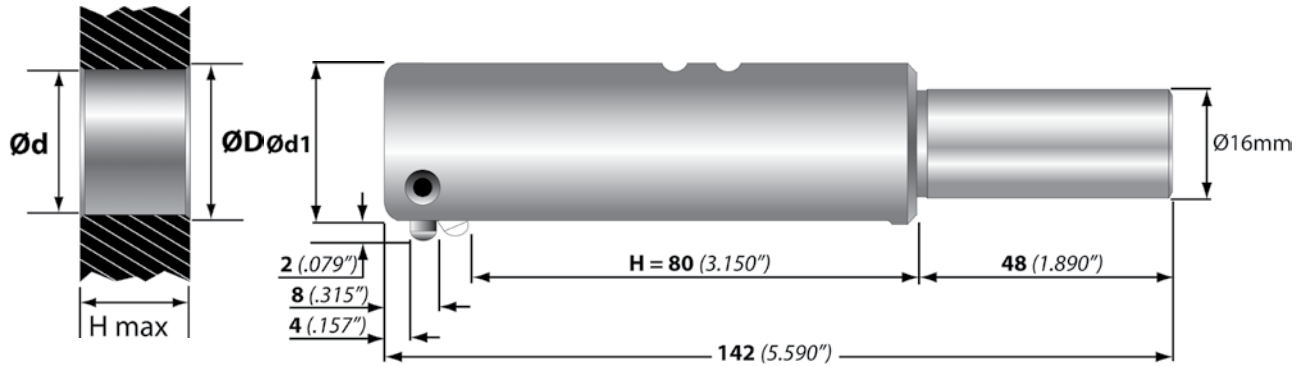

COFA Deburring Series 12 OVERSIZE - METRIC

$\varnothing d$	$\varnothing d1$	$\varnothing D$	Complete Tool with Blade	
Min. Hole mm inches	Tool Dia. mm inches	Approx. Cutting Dia. mm inches	Front and Back Order Number	Back Only Order Number
20.5 .807	20.3 .799	21.8 .858	COFA12-20.5-□	COFA12b-20.5-□
20.8 .819	20.6 .811	22.2 .874	COFA12-20.8-□	COFA12b-20.8-□
21.0 .827	20.8 .819	22.4 .882	COFA12-21.0-□	COFA12b-21.0-□
21.2 .835	21.0 .827	22.6 .890	COFA12-21.2-□	COFA12b-21.2-□
21.5 .847	21.3 .838	23.0 .906	COFA12-21.5-□	COFA12b-21.5-□
22.0 .866	21.8 .858	23.4 .921	COFA12-22.0-□	COFA12b-22.0-□
22.5 .886	22.3 .878	23.9 .941	COFA12-22.5-□	COFA12b-22.5-□
22.8 .898	22.6 .890	24.2 .953	COFA12-22.8-□	COFA12b-22.8-□
23.0 .905	22.8 .898	24.4 .960	COFA12-23.0-□	COFA12b-23.0-□
23.2 .914	23.0 .906	24.6 .969	COFA12-23.2-□	COFA12b-23.2-□
23.5 .925	23.3 .917	24.9 .981	COFA12-23.5-□	COFA12b-23.5-□
24.0 .945	23.8 .937	25.4 1.000	COFA12-24.0-□	COFA12b-24.0-□
24.5 .965	24.3 .953	25.9 1.020	COFA12-24.5-□	COFA12b-24.5-□
24.8 .977	24.6 .969	26.2 1.031	COFA12-24.8-□	COFA12b-24.8-□
25.0 .984	24.8 .976	26.6 1.047	COFA12-25.0-□	COFA12b-25.0-□
25.5 1.004	25.3 .996	26.9 1.059	COFA12-25.5-□	COFA12b-25.5-□
26.0 1.024	25.8 1.016	27.4 1.079	COFA12-26.0-□	COFA12b-26.0-□
26.5 1.043	26.3 1.035	27.9 1.098	COFA12-26.5-□	COFA12b-26.5-□
26.8 1.055	26.6 1.047	28.2 1.110	COFA12-26.8-□	COFA12b-26.8-□
27.0 1.063	26.8 1.055	28.4 1.118	COFA12-27.0-□	COFA12b-27.0-□
27.2 1.071	27.0 1.063	28.6 1.126	COFA12-27.2-□	COFA12b-27.2-□
27.5 1.083	27.3 1.075	28.9 1.138	COFA12-27.5-□	COFA12b-27.5-□
28.0 1.102	27.8 1.094	29.4 1.157	COFA12-28.0-□	COFA12b-28.0-□
28.5 1.122	28.3 1.114	29.9 1.177	COFA12-28.5-□	COFA12b-28.5-□
29.0 1.142	28.8 1.134	30.4 1.197	COFA12-29.0-□	COFA12b-29.0-□
29.5 1.162	29.3 1.154	30.9 1.217	COFA12-29.5-□	COFA12b-29.5-□
30.0 1.181	29.8 1.173	31.4 1.236	COFA12-30.0-□	COFA12b-30.0-□

Spring Choice: W, H, S, Z, Z1, Z2, Z3

BLADE
OPTIONS **PG. 53**

SPARE
PARTS **PG. 41**

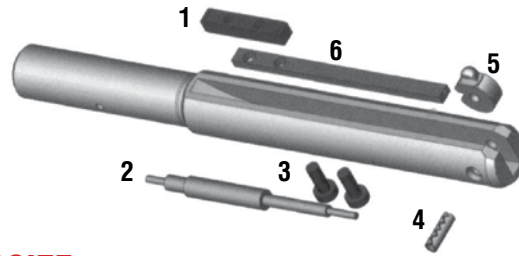

Spare Parts – COFA 12 OVERSIZE

1	2	3	4	5	6
Retainer Block	Assembly Pin	Screw	Roll Pin	Blade	Spring
GH-C-E-0800	GH-C-V-0130	GH-H-S-0513	GH-C-E-0807	See Below	See Below

Spring Options:

The cutting force of the COFA tool is controlled by a flat spring. Choose the proper spring for the material being machined.

Spring Code	Order Number	Typical Materials <i>Large or Heavy Burrs may require a stronger spring</i>	
W	GH-C-E-0361	Softer ↑ ↓ Harder	Aluminum, Brass, Magnesium
H	GH-C-E-0362		Grey Cast Iron, Nodular Iron
S	GH-C-E-0363		Carbon Steel, Free Machining Steel
Z	GH-C-E-0364		Long Chipping Steel, Stainless
Z1	GH-C-E-0365		Titanium, Hardened Steel, Nickel Alloy
Z2	GH-C-E-0366		Nickel Alloy, etc
Z3	GH-C-E-0367		Nickel Alloy, etc

Blade Options:

Blades are available from stock as front and back cutting (fab) or back cutting only (bco).

Blade Code	Blade Type	Geo.	Series 12
b	TiALN 20° Standard	fab	GH-C-M-0007
		bco	GH-C-M-0017
y	TiALN 10° Flat Surfaces	fab	GH-C-M-0467
yb		bco	GH-C-M-0477
x	TiALN 30° Uneven Spec	fab	GH-C-M-0105
xb		bco	GH-C-M-0104

How to Order:

Ordering is simple. The COFA tool provides different blade and spring options to create the most effective tool for any application depending on the hole geometry and type of material being machined.

1. Choose the tool that best fits the hole diameter.
2. Choose the blade that best fits the hole geometry.
3. Choose the spring that best fits the material.

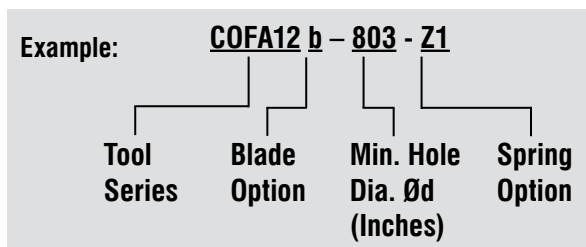

PROGRAMMING PG. 46-47

CHANGE BLADES PG. 48-51

HTC015

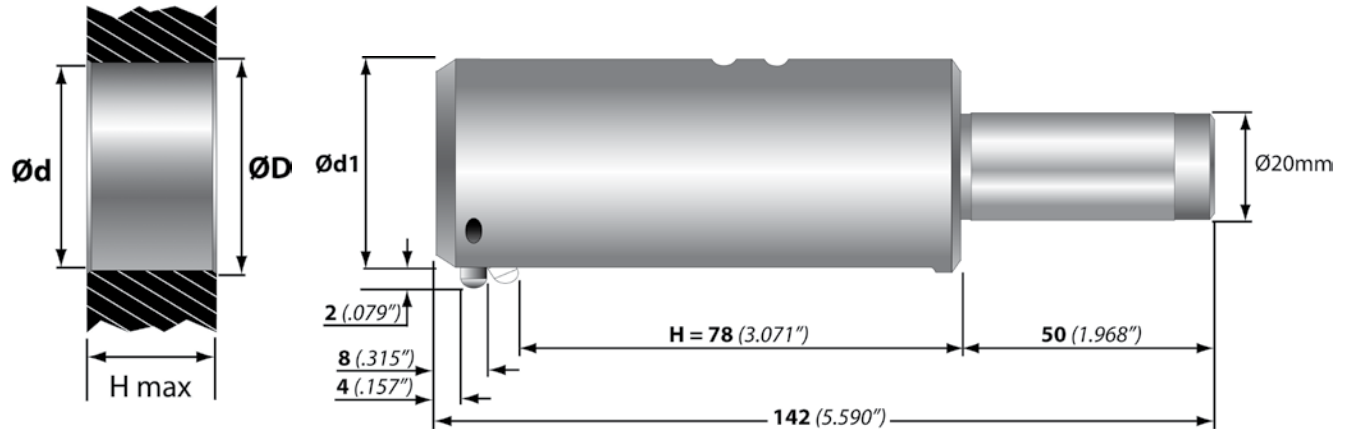

COFA Deburring Series 12 OVERSIZE - METRIC

$\varnothing d$	$\varnothing d1$	$\varnothing D$	Complete Tool with Blade	
Min. Hole mm inches	Tool Dia. mm inches	Approx. Cutting Dia. mm inches	Front and Back Order Number	Back Only Order Number
30.5 1.201	30.3 1.193	31.9 1.256	COFA12-30.5-□	COFA12b-30.5-□
31.0 1.221	30.8 1.213	32.4 1.276	COFA12-31.0-□	COFA12b-31.0-□
31.5 1.240	31.3 1.232	32.9 1.295	COFA12-31.5-□	COFA12b-31.5-□
32.0 1.260	31.8 1.252	33.4 1.315	COFA12-32.0-□	COFA12b-32.0-□
32.5 1.280	32.3 1.272	33.9 1.335	COFA12-32.5-□	COFA12b-32.5-□
33.0 1.299	32.8 1.291	34.4 1.354	COFA12-33.0-□	COFA12b-33.0-□
33.5 1.318	33.3 1.311	34.9 1.374	COFA12-33.5-□	COFA12b-33.5-□
34.0 1.339	33.8 1.331	35.4 1.394	COFA12-34.0-□	COFA12b-34.0-□
34.5 1.358	34.3 1.350	35.9 1.413	COFA12-34.5-□	COFA12b-34.5-□
35.0 1.378	34.8 1.370	36.4 1.433	COFA12-35.0-□	COFA12b-35.0-□
35.5 1.398	35.3 1.390	36.9 1.453	COFA12-35.5-□	COFA12b-35.5-□
36.0 1.417	35.8 1.409	37.4 1.472	COFA12-36.0-□	COFA12b-36.0-□
36.5 1.437	36.3 1.429	37.9 1.492	COFA12-36.5-□	COFA12b-36.5-□
37.0 1.457	36.8 1.449	38.4 1.512	COFA12-37.0-□	COFA12b-37.0-□
37.5 1.477	37.3 1.469	38.9 1.531	COFA12-37.5-□	COFA12b-37.5-□
38.0 1.496	37.8 1.488	39.4 1.551	COFA12-38.0-□	COFA12b-38.0-□
38.5 1.516	38.3 1.508	39.9 1.571	COFA12-38.5-□	COFA12b-38.5-□
39.0 1.536	38.8 1.528	40.4 1.591	COFA12-39.0-□	COFA12b-39.0-□
39.5 1.555	39.3 1.547	40.9 1.610	COFA12-39.5-□	COFA12b-39.5-□
40.0 1.575	39.8 1.567	41.4 1.630	COFA12-40.0-□	COFA12b-40.0-□

Spring Choice: W, H, S, Z, Z1, Z2, Z3

BLADE
OPTIONS **PG. 53**

SPARE
PARTS **PG. 43**

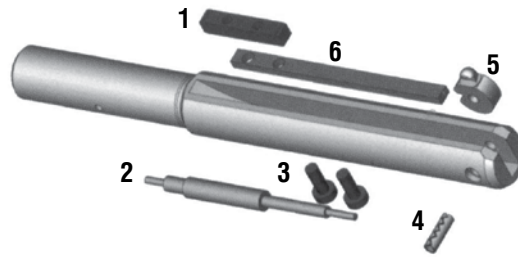

Spare Parts – COFA 12 OVERSIZE

1	2	3	4	5	6
Retainer Block	Assembly Pin	Screw	Roll Pin	Blade	Spring
GH-C-E-0800	GH-C-V-0130	GH-H-S-0513	GH-C-E-0807	See Below	See Below

Spring Options:

The cutting force of the COFA tool is controlled by a flat spring. Choose the proper spring for the material being machined.

Spring Code	Order Number	Typical Materials <i>Large or Heavy Burrs may require a stronger spring</i>	
W	GH-C-E-0361	Softer ↑ Harder	Aluminum, Brass, Magnesium
H	GH-C-E-0362		Grey Cast Iron, Nodular Iron
S	GH-C-E-0363		Carbon Steel, Free Machining Steel
Z	GH-C-E-0364		Long Chipping Steel, Stainless
Z1	GH-C-E-0365		Titanium, Hardened Steel, Nickel Alloy
Z2	GH-C-E-0366		Nickel Alloy, etc
Z3	GH-C-E-0367		Nickel Alloy, etc

Blade Options:

Blades are available from stock as front and back cutting (fab) or back cutting only (bco).

Blade Code	Blade Type	Geo.	Series 12
	TiALN 20° Standard	fab	GH-C-M-0007
b		bco	GH-C-M-0017
y	TiALN 10° Flat Surfaces	fab	GH-C-M-0467
yb		bco	GH-C-M-0477
x	TiALN 30° Uneven Spec	fab	GH-C-M-0105
xb		bco	GH-C-M-0104

How to Order:

Ordering is simple. The COFA tool provides different blade and spring options to create the most effective tool for any application depending on the hole geometry and type of material being machined.

1. Choose the tool that best fits the hole diameter.
2. Choose the blade that best fits the hole geometry.
3. Choose the spring that best fits the material.

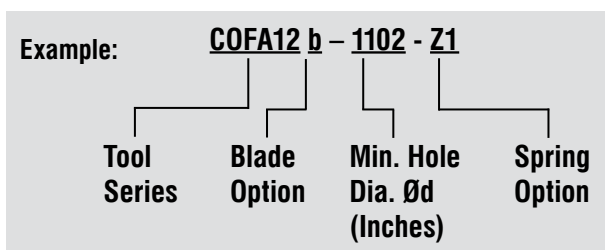

PROGRAMMING PG. 46-47

CHANGE BLADES PG. 48-51

HTC015

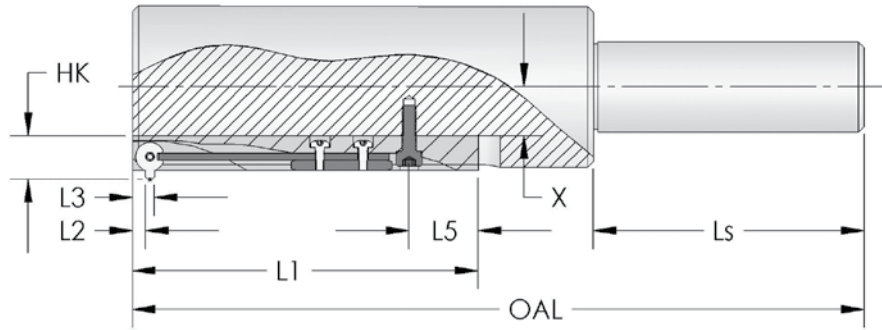
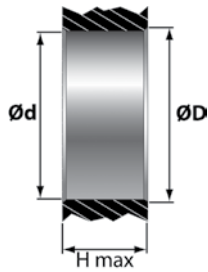

Ød	Hole Diameter
ØD	Chamfer Diameter
Ød1	Tool Diameter
x	Offset from Center

Order Number (Cassette Only)	Minimum Hole Ød mm inches	L1	L2	L3	HK	L5	BK	Ød1
COFA6-CAS-□	13 .512	60 2.36	2.0 .079	4.0 .157	7.55 .297	12 .472	7.6 .299	Ød - 1.1
COFA8-CAS-□	16 .630	80 3.15	2.5 .098	5.5 .216	9.65 .380	20 .787	9.0 .354	Ød - 1.4
COFA12-CAS-□	25 .984	93 3.66	4.0 .157	8.0 .315	15.0 .590	16 .630	14.0 .551	Ød - 2.5

Spring Choice: W, H, S, Z, Z1, Z2, Z3

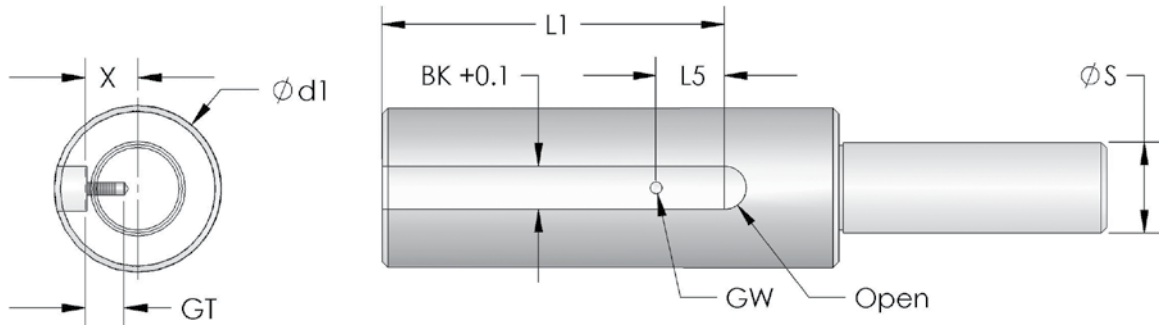

Cassette	Calc. of the "X" - Offset	GW	GT	OAL (min)	OAL	Ød
Series 6 (ØDmax= Ød + 1.1)	$X = \text{Ød}/2 - 6.6$	M2.5	6 .236	70 + Ls	Customer Specific:	Customer Specific:
Series 8 (ØDmax= Ød + 1.4)	$X = \text{Ød}/2 - 8.3$	M3	7.5 .295	90 + Ls		
Series 12 (ØDmax= Ød + 1.8)	$X = \text{Ød}/2 - 13.1$	M4	8.0 .315	103 + Ls		

Recommended Dimensions		
Ød1	Shank ØS	Ls
Ø13 - 16	Ø1/2 s.s.	47 1.850
Ø16 - 30	Ø5/8 s.s.	48 1.890
Ø30 - 50	Ø1" s.s.	58 2.283
Ø50+	Ø1.125 s.s.	58 2.283

BLADE OPTIONS PG. 53

SPARE PARTS PG. 45

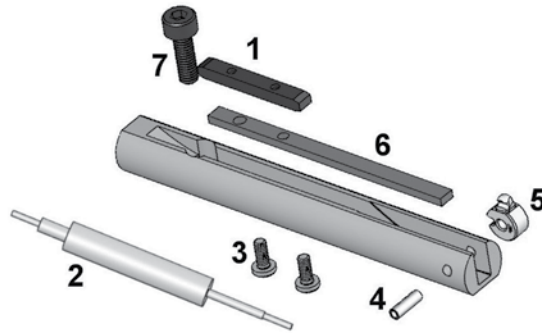

Spare Parts – Cassette

	1	2	3	4	5	6	7
Cassette	Retainer Block	Assembly Pin	Screw	Roll Pin	Blade	Spring	Cap Screw
SERIES 6	GH-C-E-0812	GH-C-V-0126	GH-H-S-0803	GH-C-E-0811	See Below	See Below	GH-H-S-0533
SERIES 8	GH-C-E-0808	GH-C-V-0111	GH-H-S-0517	GH-C-E-0810	See Below	See Below	GH-H-S-0538
SERIES 12	GH-C-E-0800	GH-C-V-0100	GH-H-S-0530	GH-C-E-0801	See Below	See Below	GH-H-S-0519

Spring Options:

The cutting force of the COFA tool is controlled by a flat spring. Choose the proper spring for the material being machined.

Spring Code	Typical Materials <i>Large or Heavy Burrs may require a stronger spring</i>	Series 6	Series 8	Series 12	
W	Softer ↑ Harder	Alum., Brass, Magnesium	GH-C-E-0321	GH-C-E-0331	GH-C-E-0361
H		Cast Iron, Nodular Iron	GH-C-E-0322	GH-C-E-0332	GH-C-E-0362
S		Steel, Free Machining Steel	GH-C-E-0323	GH-C-E-0333	GH-C-E-0363
Z		Long Chip Steel, Stainless	GH-C-E-0324	GH-C-E-0334	GH-C-E-0364
Z1		Ti, Hardened Steel, Ni Alloy	GH-C-E-0325	GH-C-E-0335	GH-C-E-0365
Z2		Nickel Alloy, etc	GH-C-E-0326	GH-C-E-0336	GH-C-E-0366
Z3		Nickel Alloy, etc	GH-C-E-0327	GH-C-E-0337	GH-C-E-0367

Blade Options:

Blades are available from stock as front and back cutting (fab) or back cutting only (bco).

Blade Code	Blade Type	Geo.	Series 6	Series 8	Series 12
b	TiN 20° Standard	fab	GH-C-M-0002	GH-C-M-0003	GH-C-M-0007
		bco	GH-C-M-0012	GH-C-M-0013	GH-C-M-0017
y	TiALN 10° Flat Surfaces	fab	GH-C-M-0462	GH-C-M-0463	GH-C-M-0467
yb		bco	GH-C-M-0472	GH-C-M-0473	GH-C-M-0477
x	TiN 30° Uneven Spec	fab	GH-C-M-0142	GH-C-M-0133	GH-C-M-0105
xb		bco	GH-C-M-0143	GH-C-M-0131	GH-C-M-0104

PROGRAMMING PG. 46-47

CHANGE BLADES PG. 48-51

Technical Information

For the standard COFA tool, the maximum cross hole to main hole ratio is 2:1 and the maximum surface angle is 15°. Above these values, the cutting insert may not have enough clearance. With irregular surfaces, the RPM must be lowered but the feed rate is unaffected. Deburr more extreme contours by using the 30° blade with extra clearance relief.

$$H = d/D$$

$$H \text{ max} = 0.5$$

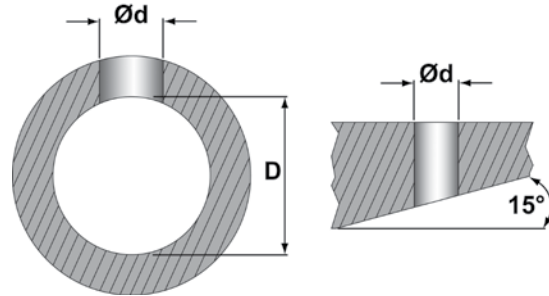

Spring Information

The spring gives cutting force to the carbide blade and the COFA tool easily accommodates several spring sizes. For easier cutting materials such as aluminum, a softer “W” spring is recommended. For harder materials or alloys, a stiffer spring is recommended.

*Recommended 10° cutting blades

MATERIAL			FEED (IPR)	Ø2 - Ø6 SPEED (SFM) Carbide-TiN		Ø6- Ø40 SPEED (SFM) Carbide-TiN	
	BHN	Spring Index		Flat*	Uneven	Flat*	Uneven
Low Carbon Steels 1010, 1020, 1513	100-200	H-Z	0.008-0.014	60-160	45-95	190-340	120-260
Med. Carbon Steels 1030, 1040, 1050, 1524	125-250	H-Z	0.008-0.014	65-130	40-75	180-280	100-200
Free Machining Alloy 4140, 4150, 4130	125-250	H-S	0.008-0.014	67-100	33-65	180-240	90-180
	125-340	S-Z	0.006-0.012	45-95	22-65	120-200	60-140
High Alloy Steel 4340	250-350	S-Z1	0.006-0.010	45-85	22-65	120-200	60-140
Stainless Steel 301, 316, 17-4PH etc.	140-250	S-Z2	0.006-0.010	33-110	15-45	100-175	40-110
Steel Castings	90-225	H-S	0.008-0.012	50-110	33-75	130-240	90-200
	150-250	Z	0.006-0.010	22-75	11-45	60-120	30-100
Gray Cast Iron	150-250	H	0.008-0.016	50-110	22-65	130-330	60-110
	200-330	H-S	0.007-0.012	22-75	18-45	90-210	50-140
Nodular Cast Iron	125-260	H	0.008-0.012	50-130	26-65	130-300	70-180
	200-300	H-S	0.006-0.012	40-105	18-45	100-180	50-140
Aluminum Alloys	30-180	W-H	0.008-0.016	75-225	30-110	200-600	80-250
Nickel Base Alloys	140-220	Z1-Z3	0.005-0.010	11-38	7-25	30-80	20-50
	220-310	Z2-Z3	0.004-0.008	7-29	7-20	20-45	15-40
Titanium Alloys		Z1-Z3	0.005-0.010	11-38	7-30	30-80	15-50

For Front & Back Deburring		For Back Only Deburring
Step 1: Referencing the front of the tool. Rapid traverse the tool the distance "A" into the hole. This will give .040"(1) clearance from the cutter.		For back deburring only, the COFA tool can rapid traverse through the top hole without damage to your hole surface.
Step 2: In forward working feed machine the top surface of the hole by moving to distance "B". (Ref. the front of the tool)		
Step 3: Rapid traverse through the hole. The hole will not be damaged.		Step 1: Rapid traverse through the hole. The hole cannot be damaged.
Step 4: In order to make the blade pop out again, the tool has to be positioned beyond the rear bore edge by the distance "C". (Ref. the front of the tool)		Step 2: In order to make the blade pop out again, the tool has to be positioned beyond the rear bore edge by the distance "C". (Ref. the front of the tool)
Step 5: (optional) Travel the tool in back rapid feed below the rear material surface of the hole or burr to reduce cycle time. Move to distance "D". (Ref. the front of the tool)		Step 3: (optional) Travel the tool in back rapid feed below the rear material surface of the hole or burr to reduce cycle time. Move to distance "D". (Ref. the front of the tool)
Step 6: In back working feed, move to distance "E" to machine the rear surface. (Ref. the front of the tool) Rapid out.		Step 4: In back working feed, move to distance "E" to machine the rear surface. (Ref. the front of the tool) Rapid out.

Tool Type	A	B-Flat	B-Irregular	C*	D*	E-Flat*	E-Irregular*
COFA 2	.067" (1.7)	.177" (4.5)	.194" (4.9)	.177" (4.5)	.169" (4.3)	.059" (1.5)	.040" (1.0)
COFA 3	.098" (2.5)	.236" (6.0)	.260" (6.6)	.236" (6.0)	.217" (5.5)	.078" (2.0)	.055" (1.4)
COFA 4	.079" (2.0)	.217" (5.5)	.240" (6.1)	.217" (5.5)	.209" (5.3)	.071" (1.8)	.048" (1.2)
COFA 5	.090" (2.3)	.276" (7.0)	.286" (7.3)	.272" (6.9)	.252" (6.4)	.087" (2.2)	.037" (0.9)
COFA 6	.039" (1.0)	.217" (5.5)	.258" (6.5)	.236" (6.0)	.197" (5.0)	.020" (0.5)	-.018" (-0.5)
COFA 8	.059" (1.5)	.276" (7.0)	.324" (8.2)	.315" (8.0)	.256" (6.5)	.0 (0)	-.049" (-1.2)
COFA 12	.118" (3.0)	.394" (10)	.468" (11.9)	.472" (12)	.354" (9.0)	.079" (2.0)	0

*Plus Material Thickness

How to Change the Blades COFA Series 2 and 3 with Fixture:

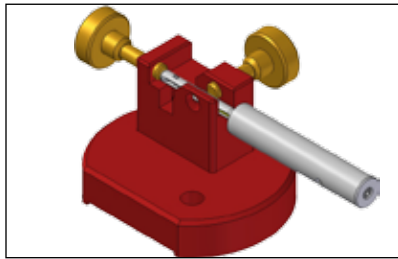

The COFA C2 and C3 blades can be installed and removed by clamping the tool in the COFA assembly fixture.

Fixture Order Number:
C3-V-0002

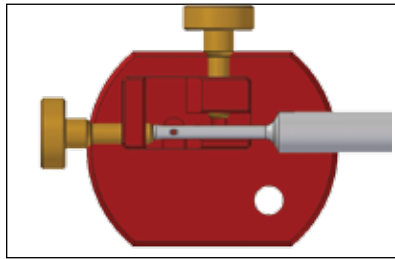

Position the blade pin hole over the fixture pin hole by adjusting the set screw at the end of the assembly fixture.

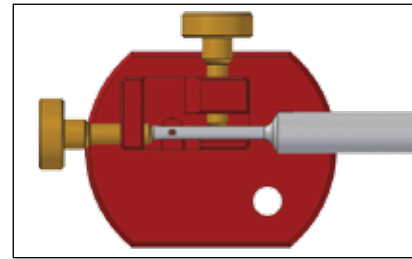

Lay the tool firmly into the assembly fixture, positioning the tool with the longer spring slot facing the clamping screw. Tighten the clamping screw.

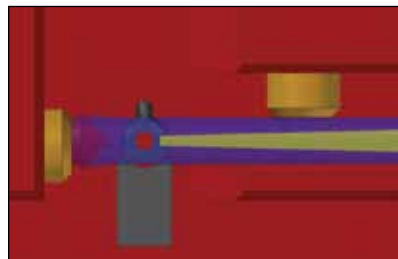

Install the blade into the blade window, nose first, so the nose of the blade is on the same side as the larger spring slot opening. Make sure, the bottom slot on the blade is engaged with the end of the spring.

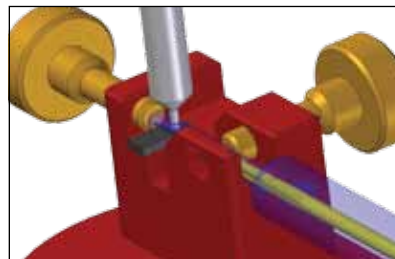

Use the assembly pin to make sure the blade hole and the pin hole are aligned. Press the assembly pin all the way through to the larger diameter.

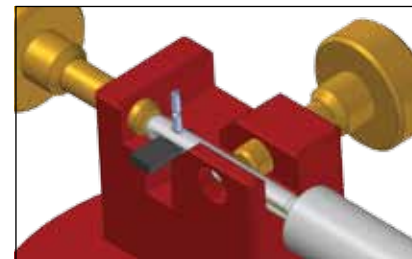

Remove the assembly pin and install the longer (and smaller diameter) of the split pin into the pin hole and blade hole.

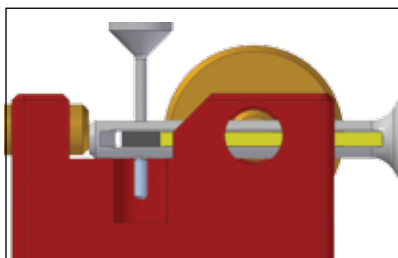

Carefully using the other end of the assembly pin drive the split pin flush with the pin hole of the tool.



Remove the tool from the fixture. Using your fingers break off the blade tab and longer end of the split pin.

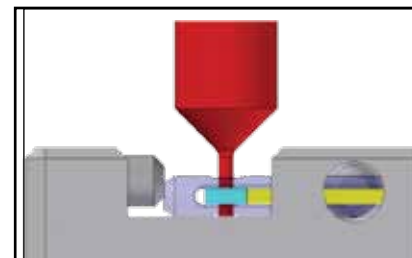

Disassembly: With the tool in the fixture, position tool with longer spring slot facing opposite of the clamp screw. Tighten. Use the small end of the pin, drive the split pin out. With the help of the small end of the pin, push the blade out.

*COFA assembly fixture is not mandatory to remove blades

How to Change the Blades COFA Series 4 and 5 with Fixture:



Assembly device for tool types COFA 4 and 5.

Fixture Order Number:
GH-C-V-0541

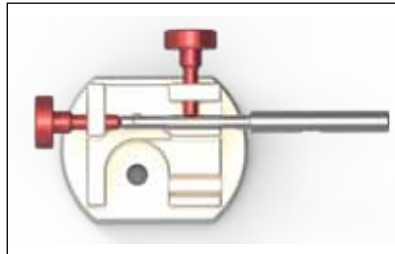

Position the tool so that the larger spring recess of the shaft is on the clamp screw side and the pin hole is over the assembly fixture hole. Tighten the clamping screw to secure the tool.

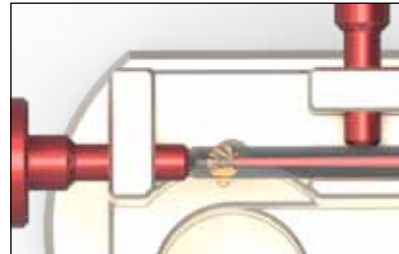

Insert the blade into the tool with the blade groove orientated towards the spring. Please observe the marks on the tool body.

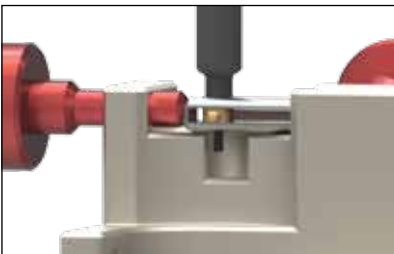

For positioning, push the long end of the assembly pin through the bore.

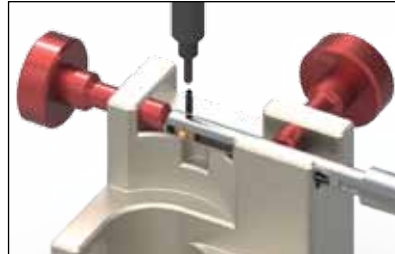

Insert the solid end of the split pin in the hole. Then push it with the assembly pin.

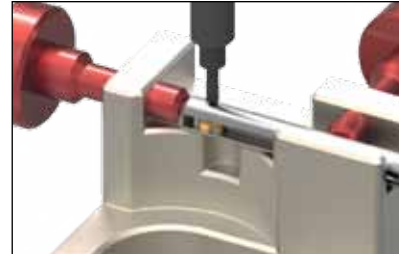

The assembly pin must be flush with both sides of the tool body.



Disassembly: Position the tool so the pin hole is over the fixture pin hole and the solid end of the split pin is facing up.



Push the roll pin carefully out of the bore. If necessary, use a small hammer.

How to Change the Blades COFA Series 2, 3, 4 and 5:

Step 1:

Line up the assembly pin on the side with the solid end of the split pin (opposite side of the split end).

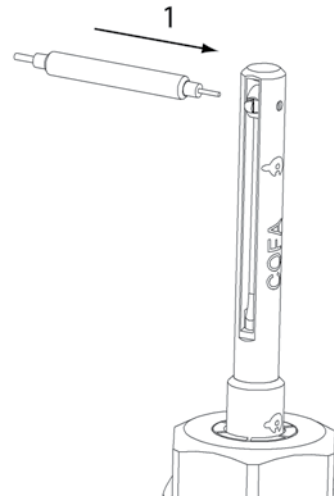

Step 2:

(2a) Remove the split pin out of the tool body by pressing the assembly pin from the solid end of the split pin. (2b) The blade will fall out of the tool. Carefully use a hammer if necessary.

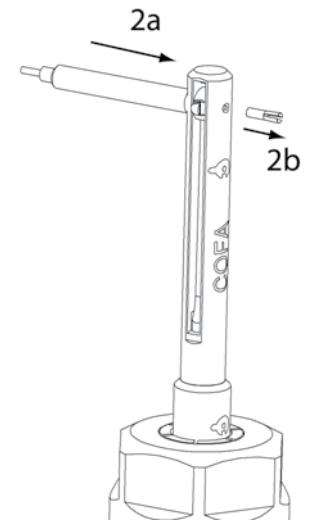

NOTE:

HEULE recommends that you use a new split pin with each blade change and throw out the old pin.

Step 3:

Insert the blade in the tool body with the notch down towards the spring. Use the mark on the tool body to reference the correct position.

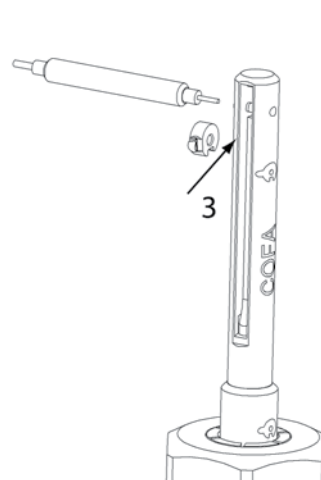

Step 4:

(4a) Line up the blade with the split pin hole using the assembly pin given with each tool. (4b) Insert the solid end of the split pin in the hole on the opposite side of the assembly pin and manually press into place. Using a small hammer or mallet, carefully press in the split pin on the split end into the hole.

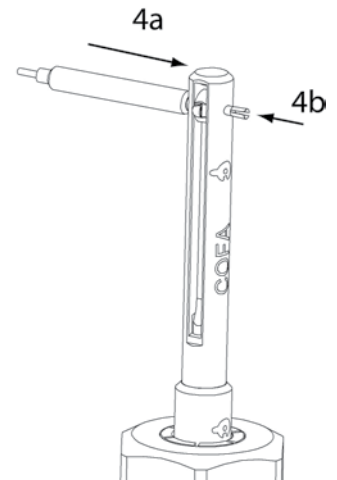

IMPORTANT:

The split pin must be below the tool body surface. If necessary, use the assembly pin and hammer to press the split pin completely in. Make sure it does not stick out on either side of the tool body.

Step 5:

Series 2 and 3 Only: Using your fingers break off the blade tab and longer end of the split pin.

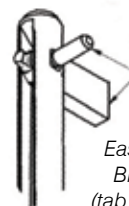

*Easy to change
Blade and pin
(tab that snaps off)*

How to Change the Blades COFA Series 6, 8, and 12:

STEP 1:

Insert the long end of the assembly pin into the roll pin.

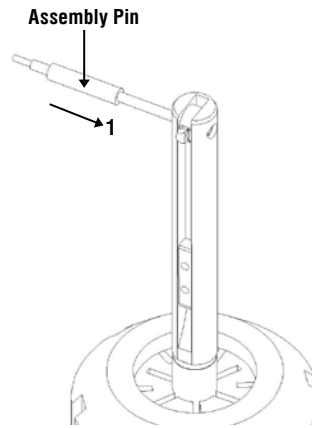

STEP 2:

Drive the roll pin out of the tool body. Keep the roll pin to reuse it.

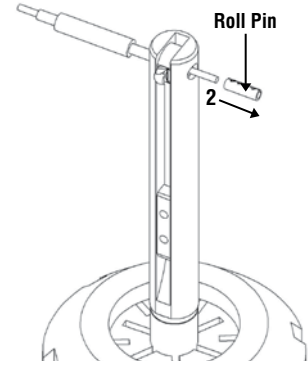

STEP 3:

Remove the assembly pin and then remove the blade.

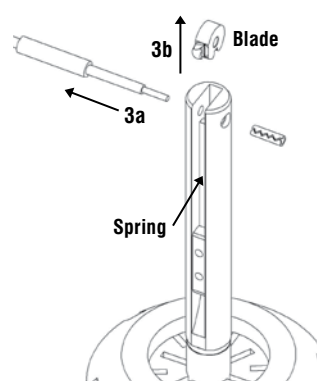

STEP 4:

Place new blade into the tool with the notch on the end of the spring.

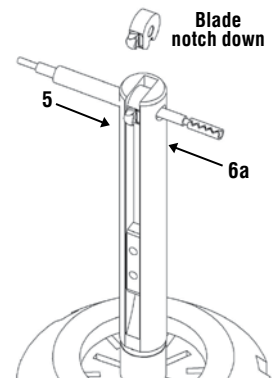

STEP 5:

Place the long end of the assembly pin through the holes to align the blade in the tool.

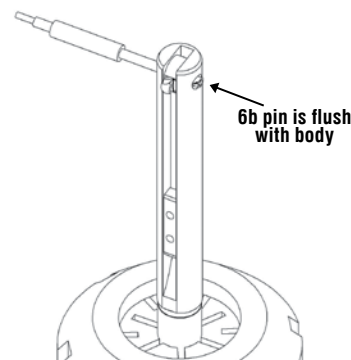

STEP 6:

Place the roll pin on the end of the assembly pin and hammer it into the tool. Use the assembly pin to maintain the proper alignment.

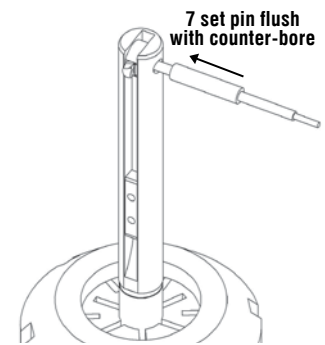

STEP 7:

Place the short end of the assembly pin into the roll pin and drive the assembly pin so it seats against the counterbore.

PROBLEM	EXPLANATION	SOLUTION
Chamfer Ø too large	<ul style="list-style-type: none"> • Tool is designed to cut to a set chamfer diameter 	<ul style="list-style-type: none"> • Select a smaller sized tool
Chamfer Ø too small	<ul style="list-style-type: none"> • Chamfer is cutting to the designated maximum from the catalog but this is not large enough • Chamfer is not to designed maximum size 	<ul style="list-style-type: none"> • Use the next size larger tool if possible • The COFA tool is only designed for edge breaks but specials can be requested • Use the next higher strength spring • Use a slower feed rate
Tool chatters	<ul style="list-style-type: none"> • Operating conditions are not correct • Not enough cutting force for your material 	<ul style="list-style-type: none"> • Increase feed rates • Decrease speed rates • Use coolant on tool • Use the next higher strength spring
Tool is pushing the burr	<ul style="list-style-type: none"> • Blade is used or dull • Blade is new but still not working 	<ul style="list-style-type: none"> • Change the insert • Use the next higher strength spring • Check programming position and feed rates • Burrs are too large
Tool creates a secondary burr or poor surface finish	<ul style="list-style-type: none"> • Spring is too heavy • Chamfer size is large • Operating conditions are not correct 	<ul style="list-style-type: none"> • Use next lighter strength spring • Use a smaller tool to achieve a smaller edge break • Check recommended feed and speed rates
Cutting Blades are chipping	<ul style="list-style-type: none"> • Programming error • Interrupted cut or possible wall interference 	<ul style="list-style-type: none"> • Make sure cutting edge is not in fast feed when cutting • Try smaller tool • Reduce speed rate
Uneven chamfer or missing some burrs	<ul style="list-style-type: none"> • Speed rate far too high • Ratio between crosshole and tube diameter (d:D) is larger than 0.5 • Not enough cutting force for your material 	<ul style="list-style-type: none"> • Special inserts are possible • Change spring or use the next higher strength spring
Blade is breaking or falling out of tool	<ul style="list-style-type: none"> • Interrupted cut or possible wall interference • Roll pins are being deformed • Program is incorrect 	<ul style="list-style-type: none"> • Try smaller tool • Check assembly procedures • Assembly pins must be used when changing blades • Change roll pin • Check programming positioning • Do not use bore cycle



Grinding may produce hazardous dust. To avoid adverse effects, use adequate ventilation and read MSDS. Cutting tools may break during use. To avoid injury, use proper safety precautions and protective equipment. Use the machine tool with sufficient rigidity and horsepower. Use a cover on a machine tool and protector, such as glasses, against shattering chips and broken tools due to misuse. Do not use insoluble oil because there is a danger of causing fire.

Standard Blade Options:

Standard Blades are available from stock as front and back cutting (fab) or back cutting only (bco).

Blade Code	Blade Type	Geo.	Series 2 C2-M-	Series 3 C3-M-	Series 4 GH-C-M-	Series 5 GH-C-M-	Series 6 GH-C-M-	Series 8 GH-C-M-	Series 12 GH-C-M-
b	TiN 20° Standard	fab	-0006-A*	-0006-A*	-0504	-0505	-0002	-0003	-0007
		bco	-0016-A*	-0016-A*	-0914	-0915	-0012	-0013	-0017
y	TiALN 10° Flat Surfaces	fab	-0007-A	-0007-A	-0764	-0765	-0462	-0463	-0467
yb		bco	-0017-A	-0017-A	-0874	-0875	-0472	-0473	-0477
x	TiN 30° Uneven Spec	fab	-	-	-0148	-0150	-0142	-0133	-0105
xb		bco	-	-	-0182	-0184	-0143	-0131	-0104

* TIALN is standard for COFA Series 2 and 3

Special Blade Options:

To order a standard COFA tool with a special insert (those not marked with an *), add a 'k' behind the series number to indicate the tool is without the standard insert and then order the special blades separately.

For example: 1 pc COFA8k-315-H - COFA Tool Holder without insert
5 pc GH-C-M-0083 - COFA8 Blade, DLC 10° *special*

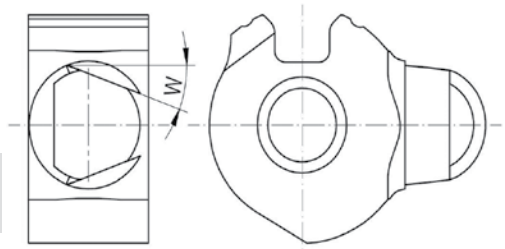

Note: These items are non-stock standard items with extended delivery time.

Blade Type	Geo.	Series 4	Series 5	Series 6	Series 8	Series 12
DLC 20° Diamond	fab	GH-C-M-0584	GH-C-M-0585	GH-C-M-0082	GH-C-M-0083	GH-C-M-0087
	bco	GH-C-M-0994	GH-C-M-0995	GH-C-M-0092	GH-C-M-0093	GH-C-M-0097
DLC 10° Flat Surfaces	fab	GH-C-M-0784	GH-C-M-0785	GH-C-M-0482	GH-C-M-0483	GH-C-M-0487
	bco	GH-C-M-0894	GH-C-M-0895	GH-C-M-0492	GH-C-M-0493	GH-C-M-0497
TiALN 20° Spec Coat	fab	GH-C-M-0564	GH-C-M-0565	GH-C-M-0062	GH-C-M-0063	GH-C-M-0067
	bco	GH-C-M-0974	GH-C-M-0975	GH-C-M-0072	GH-C-M-0073	GH-C-M-0077
TiCN 10° Flat Surfaces	fab	GH-C-M-0744	GH-C-M-0745	GH-C-M-0442	GH-C-M-0443	GH-C-M-0447
	bco	GH-C-M-0854	GH-C-M-0855	GH-C-M-0452	GH-C-M-0453	GH-C-M-0457
Uncoated 20°	fab	GH-C-M-0524	GH-C-M-0525	GH-C-M-0022	GH-C-M-0023	GH-C-M-0027
	bco	GH-C-M-0934	GH-C-M-0935	GH-C-M-0032	GH-C-M-0033	GH-C-M-0037
Uncoated 10°	fab	GH-C-M-0724	GH-C-M-0725	GH-C-M-0422	GH-C-M-0423	GH-C-M-0427
	bco	GH-C-M-0834	GH-C-M-0835	GH-C-M-0432	GH-C-M-0433	GH-C-M-0437
TiN 25° Uneven Spec	fab	GH-C-M-0161	GH-C-M-0163	GH-C-M-0113	GH-C-M-0112	GH-C-M-0103
	bco	GH-C-M-0181	GH-C-M-0183	GH-C-M-0140	GH-C-M-0141	GH-C-M-0102



Visit our website for our full line
of product brochures and videos

www.HeuleTool.com

We provide online tool selectors for the
COFA, **SNAP**, **DEFA** and **BSF** product groups.

Simply enter your application information and the correct tool will
be provided complete with order number and sample drawing.

We are also available on:



MICROSAP

MICRO SERIES Front & Back Chamfering of Small Through Holes

- Chamfers front and back surfaces in a single pass
- Provides high quality, consistent chamfers
- Coated carbide blades provide long tool life
- Sizes 2mm-5mm (.080"-.197") available from stock

The HEULE SNAP chamfering carbide tool for all purpose deburring and chamfering of through holes 2mm-5mm (.079"-.197"), front and back, and in a single pass. SNAP is a very simple tool for deburring and/or chamfering through holes on the top and bottom without reversing the spindle, dwelling, or indexing the part. The SNAP tool offers a simple to use, high quality chamfering tool with Carbide inserts coated with TiAlN to meet today's manufacturing needs.

High Quality Consistent Chamfers

The SNAP blades are ground with a patented geometry developed by HEULE to produce quality chamfers and eliminate secondary burrs. Different chamfer sizes can be achieved by selecting a different blade. There is no need for adjustments or operator intervention. In hard materials above Rc=28, request the SNAP-DF geometry.



Easy to Change Cutting Blades

Despite the very small size, the MICRO Series SNAP Tools offer a very easy blade change solution. Each cutting blade comes with extra material that is *Snapped Off* after the blade is installed. See instructions in "Technical Instructions".

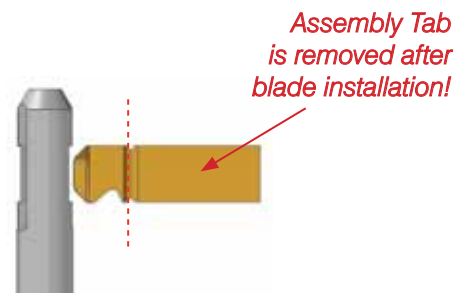

High Quality Consistent Chamfers

There are different blade options for the SNAP tool if an application requires a different chamfer than the standard 90° blade. DEFA geometry blades provide precision chamfering. DEFA is recommended for all materials above 28HRC. When deburring through holes breaking into cross holes; a min. ratio of 1:5 (Øhole:ØCross Hole) for 90° blades should be referenced.

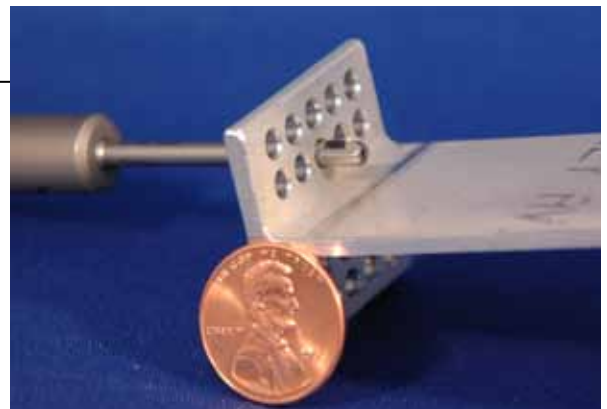

How Does It Work?

As the rotating tool is fed into the hole, the front cutting edge deburrs the top of the hole by cutting a 45° chamfer. As the tool feeds into the part, the blade is forced into the body and slides in the blade window.

When the blade is in the hole, only the ground sliding surface touches the hole protecting it from damage while the tool is fed through the part. There is no need to stop or reverse the spindle.

When the blade reaches the back of the part the coiled spring acts with the control bolt to push it back out into cutting position. The back edge is deburred and chamfered as the tool is withdrawn. When the blade is again in the hole, the tool can be rapid fed out and on the next hole.

Typical Parts



How to Select the Tool and Blade:

Selecting the proper tool is very easy and you only need to know the bore diameter and desired chamfer size. Tools are sold without blades. In most cases, there are several choices of blade sizes based on size of desired edge break. (Example: .010", .020", .030" x 45°)

Sample Tool Selection

1. Use the bore size to select a tool body. $\varnothing d$
 - Select the largest tool that fits the bore.
2. Use the desired chamfer size to select a blade. $\varnothing D$
 - Select the proper cutting blade.

Order Example:

Bore $\varnothing 0.094$ " / Chamfer $\varnothing 0.114$ " fab Alm.

Tool Holder Order Number: SNAP2-2.3-20

Blade Order Number: GH-Q-M-40071

If the application calls for different chamfer specifications, see our special blade options section for each series

HTC015

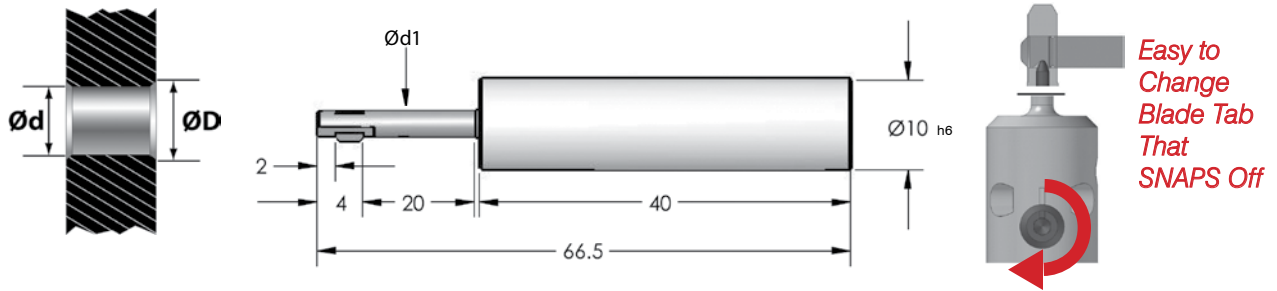

MICRO SNAP Series 2

$$(\text{ØD2} = \text{ØD} + 0.2\text{mm})$$

Minimum Hole Ø mm inches	Tool Diameter Ød1 +0/- .03 mm inches	Order Number	2. Housings Ln-20mm GH-Q-N-	9. Blade Gs, 90°, Carbide, TiAlN GH-Q-M-____ and Chamfer ØD (mm)			
				Front & Back (fab)		Back Only (bco)*	
2.0 .079	1.95 .077	SNAP2-2.0-20	-0061	--	-40031 (2.4)	--	-40631* (2.4)
2.1 .083	2.05 .081	SNAP2-2.1-20	-0062	-40031 (2.4)	-40051 (2.6)	-40631* (2.4)	-40651* (2.6)
2.2 .087	2.15 .085	SNAP2-2.2-20	-0063	-40031 (2.4)	-40051 (2.6)	-40631* (2.4)	-40651* (2.6)
2.3 .091	2.25 .089	SNAP2-2.3-20	-0064	-40051 (2.6)	-40071 (2.8)	-40651* (2.6)	-40671* (2.8)
2.4 .095	2.35 .092	SNAP2-2.4-20	-0065	-40051 (2.6)	-40071 (2.8)	-40651* (2.6)	-40671* (2.8)
2.5 .099	2.45 .097	SNAP2-2.5-20	-0066	-40071 (2.8)	-40091 (3.0)	-40671* (2.8)	-40691* (3.0)
2.6 .102	2.55 .100	SNAP2-2.6-20	-0067	-40071 (2.8)	-40091 (3.0)	-406718* (2.8)	-40691* (3.0)
2.7 .106	2.65 .104	SNAP2-2.7-20	-0068	-40091 (3.0)	-40111 (3.2)	-40691* (3.0)	-40711* (3.2)
2.8 .110	2.75 .108	SNAP2-2.8-20	-0069	-40091 (3.0)	-40111 (3.2)	-40691* (3.0)	-40711* (3.2)
2.9 .114	2.85 .112	SNAP2-2.9-20	-0070	-40111 (3.2)	-40131 (3.4)	-40711* (3.2)	-40731* (3.4)

* Limited-stock standard item with extended delivery time Note: DEFA Geometry available for material above 28Rc

BLADE
OPTIONS PG.
59

SPARE
PARTS PG.
59

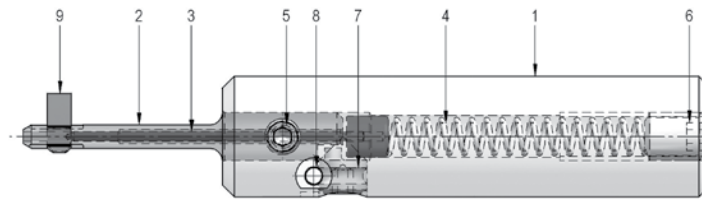

10. Wrench for Set Screw
GH-H-S-2101

Spare Parts – MICRO SNAP 2

1	2	3	4	5	6	7	8	9
Tool Body GH-Q-G-	Housing 20mm	Control 20mm GH-Q-E-	Spring GH-H-F-	Set Screw GH-H-S-	Screw GH-H-S-	Eccentric GH-S-E-	Roll Pin GH-C-E-	Blade
-5024	See pg 58	-0237	-0047	-1075	-0134	-0031	-0811	Below

Blades – MICRO SNAP 2 – GS geometry 90° angle

Max. Chamfer ØD mm Inches	fab TiAlN coated	bco TiAlN coated*	Dimensions	
			A	C
2.4 .095	GH-Q-M-40031	GH-Q-M-40631*	1.92	0.53
2.6 .102	GH-Q-M-40051	GH-Q-M-40651*	2.02	0.58
2.8 .110	GH-Q-M-40071	GH-Q-M-40671*	2.12	0.63
3.0 .118	GH-Q-M-40091	GH-Q-M-40691*	2.12	0.63
3.2 .126	GH-Q-M-40111	GH-Q-M-40711*	2.52	0.63
3.4 .134	GH-Q-M-40131	GH-Q-M-40731*	2.72	0.63

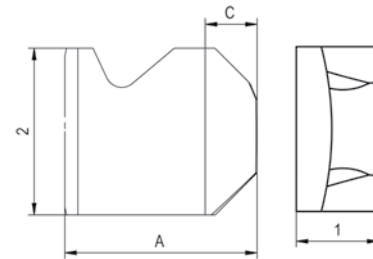

* Limited-stock standard item with extended delivery time

Blades – MICRO SNAP 2 – DF (DEFA) geometry 90° angle

Max. Chamfer ØD mm Inches	fab TiAlN coated	bco TiAlN coated*	Dimensions	
			A	C
2.4 .095	GH-Q-M-44031	GH-Q-M-44631*	1.92	0.53
2.6 .102	GH-Q-M-44051	GH-Q-M-44651*	2.02	0.58
2.8 .110	GH-Q-M-44071	GH-Q-M-44671*	2.12	0.63
3.0 .118	GH-Q-M-44091	GH-Q-M-44691*	2.12	0.63
3.2 .126	GH-Q-M-44111	GH-Q-M-44711*	2.52	0.63
3.4 .134	GH-Q-M-44131	GH-Q-M-44731*	2.72	0.63

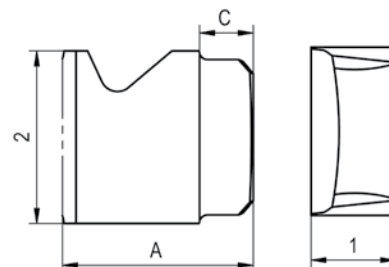

* Limited-stock standard item with extended delivery time

PROGRAMMING PG. 66-67

CHANGE BLADES PG. 64

HTC015

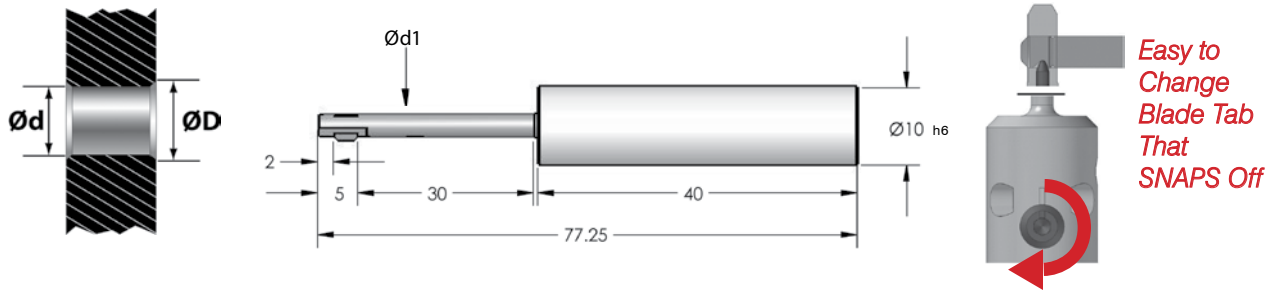

MICRO SNAP Series 3

$$(\text{ØD2} = \text{ØD} + 0.3\text{mm})$$

Minimum Hole Ø mm inches	Tool Diameter Ød1 +0/- .03 mm inches	Order Number	2. Housings Ln-30mm GH-Q-N-	9. Blade Gs, 90°, Carbide, TiAlN GH-Q-M-____ and Chamfer ØD (mm)			
				Front & Back (fab)		Back Only (bco)*	
3.0 .118	2.90 .114	SNAP3-3.0-30	-0141	-40171 (3.3)	-40201 (3.6)	-40771* (3.3)	-40801* (3.6)
3.1 .122	3.00 .118	SNAP3-3.1-30	-0142	-40201 (3.6)	-40231 (3.9)	-40801* (3.6)	-40831* (3.9)
3.2 .126	3.10 .122	SNAP3-3.2-30	-0143	-40201 (3.6)	-40231 (3.9)	-40801* (3.6)	-40831* (3.9)
3.3 .130	3.20 .126	SNAP3-3.3-30	-0144	-40231 (3.9)	-40261 (4.2)	-40831* (3.9)	-40861* (4.2)
3.4 .134	3.30 .130	SNAP3-3.4-30	-0145	-40231 (3.9)	-40261 (4.2)	-40831* (3.9)	-40861* (4.2)
3.5 .138	3.40 .134	SNAP3-3.5-30	-0146	-40231 (3.9)	-40261 (4.2)	-40831* (3.9)	-40861* (4.2)
3.6 .142	3.50 .138	SNAP3-3.6-30	-0147	-40261 (4.2)	-40291 (4.5)	-40861* (4.2)	-40891* (4.5)
3.7 .146	3.60 .142	SNAP3-3.7-30	-0148	-40261 (4.2)	-40291 (4.5)	-40861* (4.2)	-40891* (4.5)
3.8 .150	3.70 .146	SNAP3-3.8-30	-0149	-40261 (4.2)	-40291 (4.5)	-40861* (4.2)	-40891* (4.5)
3.9 .154	3.80 .150	SNAP3-3.9-30	-0150	-40291 (4.5)	-40321 (4.8)	-40891* (4.5)	-40921* (4.8)

* Limited-stock standard item with extended delivery time Note: DEFA Geometry available for material above 28Rc

BLADE
OPTIONS PG.
61

SPARE
PARTS PG.
61

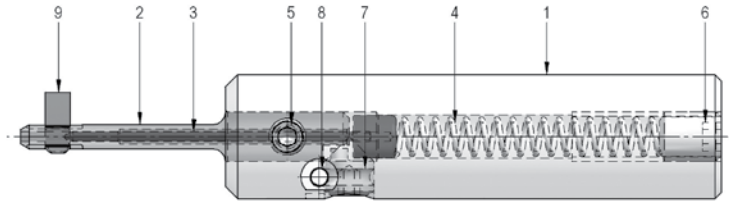

10. Wrench for Set Screw
GH-H-S-2101

Spare Parts – MICRO SNAP 3

1	2	3	4	5	6	7	8	9
Tool Body GH-Q-G-	Housing 30mm	Control 30mm GH-Q-E-	Spring GH-H-F-	Set Screw GH-H-S-	Screw GH-H-S-	Eccentric GH-S-E-	Roll Pin GH-C-E-	Blade
-5024	See pg 60	-0238	-0047	-1075	-0134	-0031	-0811	Below

Blades – MICRO SNAP 3 – GS geometry 90° angle

Max. Chamfer ØD mm Inches	fab TiAIN coated	bco TiAIN coated*	Dimensions	
			A	C
3.3 .130	GH-Q-M-40171	GH-Q-M-40771*	2.84	0.55
3.6 .142	GH-Q-M-40201	GH-Q-M-40801*	2.84	0.70
3.9 .154	GH-Q-M-40231	GH-Q-M-40831*	2.84	0.85
4.2 .165	GH-Q-M-40261	GH-Q-M-40861*	3.04	0.90
4.5 .177	GH-Q-M-40291	GH-Q-M-40891*	3.34	0.90
4.8 .189	GH-Q-M-40321	GH-Q-M-40921*	3.64	0.90

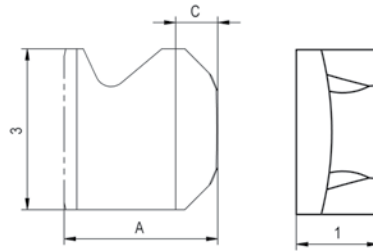

* Limited-stock standard item with extended delivery time

Blades – MICRO SNAP 3 – DF (DEFA) geometry 90° angle

Max. Chamfer ØD mm Inches	fab TiAIN coated	bco TiAIN coated*	Dimensions	
			A	C
3.3 .130	GH-Q-M-44171	GH-Q-M-44771*	2.84	0.55
3.6 .142	GH-Q-M-44201	GH-Q-M-44801*	2.84	0.70
3.9 .154	GH-Q-M-44231	GH-Q-M-44831*	2.84	0.85
4.2 .165	GH-Q-M-44261	GH-Q-M-44861*	3.04	0.90
4.5 .177	GH-Q-M-44291	GH-Q-M-44891*	3.34	0.90
4.8 .189	GH-Q-M-44321	GH-Q-M-44921*	3.64	0.90

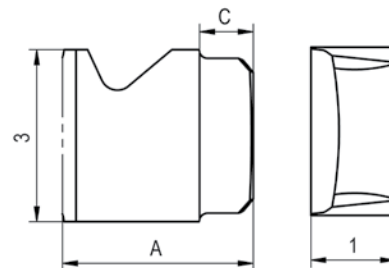

* Limited-stock standard item with extended delivery time

PROGRAMMING PG. 66-67

CHANGE BLADES PG. 64

HTC015

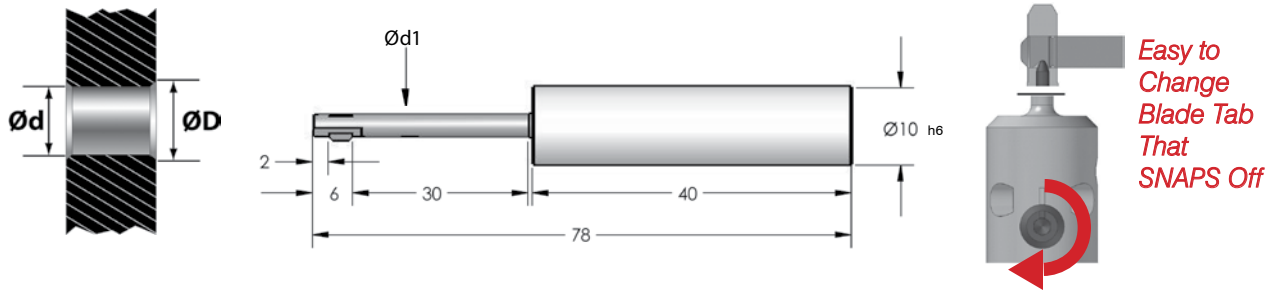

Easy to Change Blade Tab That SNAPS Off

MICRO SNAP Series 4

$$(\text{ØD2} = \text{ØD} + 0.4\text{mm})$$

Minimum Hole Ø mm inches	Tool Diameter Ød1 +0/- .03 mm inches	Order Number	2. Housings Ln-30mm GH-Q-N-	9. Blade Gs, 90°, Carbide, TiAlN GH-Q-M-____ and Chamfer ØD (mm)		
				Front & Back (fab)		
4.0 .157	3.90 .153	SNAP4-4.0-30	-0161	-40381 (4.4)	-40421 (4.8)	-40461 (5.2)
4.1 .161	4.00 .157	SNAP4-4.1-30	-0162	-40421 (4.8)	-40461 (5.2)	-40501 (5.6)
4.2 .165	4.10 .161	SNAP4-4.2-30	-0163	-40421 (4.8)	-40461 (5.2)	-40501 (5.6)
4.3 .169	4.20 .165	SNAP4-4.3-30	-0164	-40421 (4.8)	-40461 (5.2)	-40501 (5.6)
4.4 .173	4.30 .169	SNAP4-4.4-30	-0165	-40421 (4.8)	-40461 (5.2)	-40501 (5.6)
4.5 .177	4.40 .173	SNAP4-4.5-30	-0166	-40461 (5.2)	-40501 (5.6)	-40541 (6.0)
4.6 .181	4.50 .177	SNAP4-4.6-30	-0167	-40461 (5.2)	-40501 (5.6)	-40541 (6.0)
4.7 .185	4.60 .181	SNAP4-4.7-30	-0168	-40461 (5.2)	-40501 (5.6)	-40541 (6.0)
4.8 .189	4.70 .185	SNAP4-4.8-30	-0169	-40461 (5.2)	-40501 (5.6)	-40541 (6.0)
4.9 .193	4.80 .189	SNAP4-4.9-30	-0170	-40501 (5.6)	-40541 (6.0)	-40581 (6.4)
5.0 .197	4.90 .193	SNAP4-5.0-30	-0171	-40501 (5.6)	-40541 (6.0)	-40581 (6.4)

Note: DEFA Geometry available for material above 28Rc

BLADE
OPTIONS **PG. 63**

SPARE
PARTS **PG. 63**

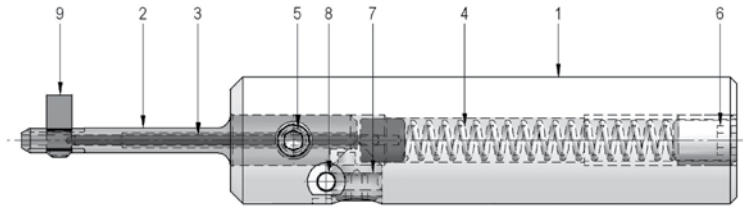

10. Wrench for Set Screw
GH-H-S-2101

Spare Parts – MICRO SNAP 4

1	2	3	4	5	6	7	8	9
Tool Body GH-Q-G-	Housing 30mm	Control 30mm GH-Q-E-	Spring GH-H-F-	Set Screw GH-H-S-	Screw GH-H-S-	Eccentric GH-S-E-	Roll Pin GH-C-E-	Blade
-5024	See pg 62	-0238	-0047	-1075	-0134	-0031	-0811	Below

Blades – MICRO SNAP 4 – GS geometry 90° angle

Max. Chamfer ØD mm Inches	fab TiAIN coated	bco TiAIN coated*	Dimensions	
			A	C
4.4 .173	GH-Q-M-40381	GH-Q-M-40981*	3.84	0.65
4.8 .189	GH-Q-M-40421	GH-Q-M-41021*	3.84	0.85
5.2 .205	GH-Q-M-40461	GH-Q-M-41061*	3.84	1.05
5.6 .220	GH-Q-M-40501	GH-Q-M-41101*	3.94	1.20
6.0 .236	GH-Q-M-40541	GH-Q-M-41141*	4.35	1.20
6.4 .252	GH-Q-M-40581	GH-Q-M-41181*	4.75	1.20

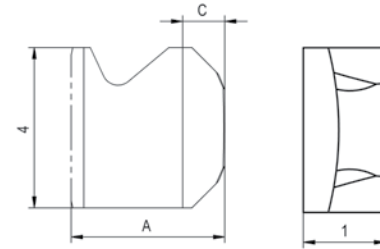

* Non-stock standard item with extended delivery time

Blades – MICRO SNAP 4 – DF (DEFA) geometry 90° angle

Max. Chamfer ØD mm Inches	fab TiAIN coated	bco TiAIN coated*	Dimensions	
			A	C
4.4 .173	GH-Q-M-44381	GH-Q-M-44981*	3.84	0.65
4.8 .189	GH-Q-M-44421	GH-Q-M-45021*	3.84	0.85
5.2 .205	GH-Q-M-44461	GH-Q-M-45061*	3.84	1.05
5.6 .220	GH-Q-M-44501	GH-Q-M-45101*	3.94	1.20
6.0 .236	GH-Q-M-44541	GH-Q-M-45141*	4.35	1.20
6.4 .252	GH-Q-M-44581	GH-Q-M-45181*	4.75	1.20

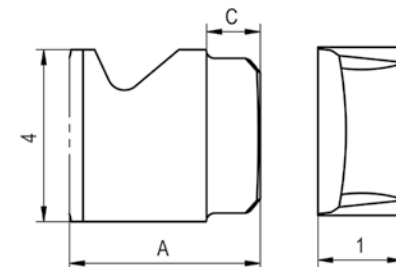

* Non-stock standard item with extended delivery time

PROGRAMMING PG. 66-67

CHANGE BLADES PG. 64

HTC015

Changing the Blade - MICRO SNAP Series 2, 3, & 4

Blade Removal

Step 1:

With 1.5mm Hex Wrench (1), Turn eccentric screw (2) 180° until notch points down (opposite of blade).

Step 2:

The Control Bolt (3) is lowered and the blade (4) is now free to fall out or can be pushed out with a new blade.

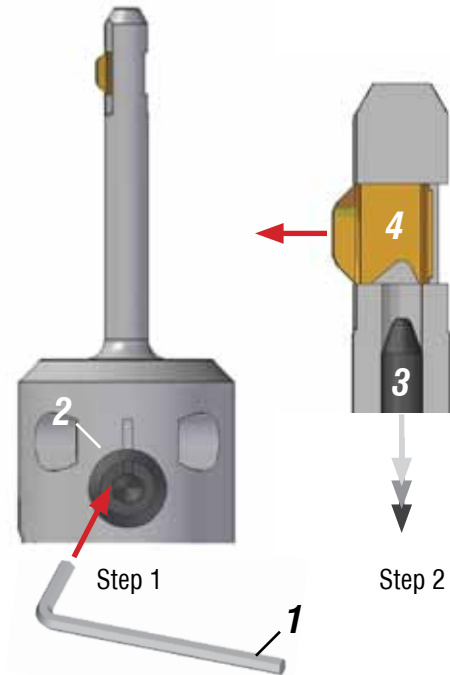

Installing NEW Blade

Step 3:

With the eccentric screw (2) 180° notch still pointing down (opposite of blade); install a NEW blade with assembly tab (5) into the blade window (6) opposite side of the chip flat.

Step 4:

Install the blade so the pin groove of the blade is located over the Control Bolt (3). The cutting side of the blade should be visible.

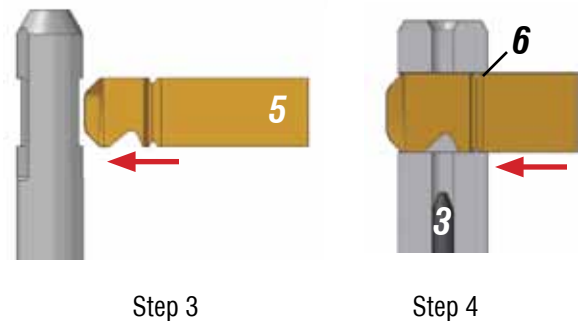

Step 5:

Using the 1.5mm Hex Wrench (1), turn the eccentric screw (2) 180° so the notch is back towards the blade. The Control Bolt (3) will move up. Check that the blade is locked into the tool.

Step 6:

To remove the assembly tab (5); slightly pull back on the assembly tab so the blade is still engaged but the score mark is located close to the edge of the window. Then, using a back and forth movement break-off the assembly tab. Discard or recycle the carbide tab.

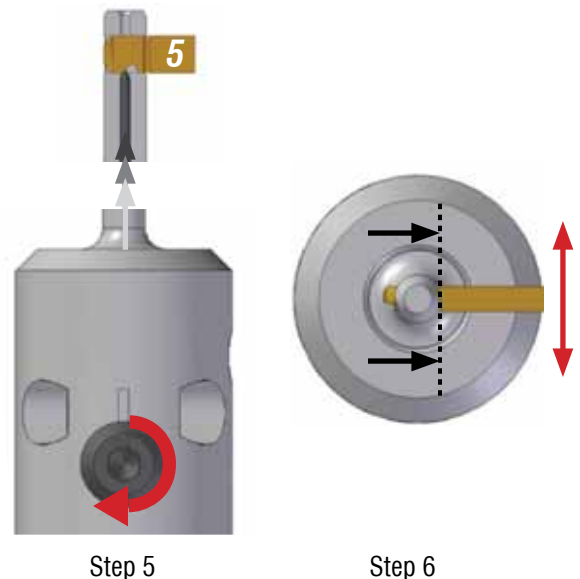

Adjusting the Chamfer Size

Chamfer size is based on the size of the blade. Both the blade force and the feed rate can be adjusted to slightly increase or decrease the chamfer size. The maximum chamfer size may not be possible when cutting harder materials such as those with hardness Rc>28 or exotic alloys. It is recommended to use our DEFA (DF) geometry when cutting difficult material or large burr formations.

ATTENTION: MAXIMUM FEED RATE OF "DF" GEOMETRY IS 0.003 IPR!!

Setting the Blade Force

The blade force can be adjusted with the set screw in the end of the shank. The blade force should be enough to ensure the blade extends completely after passing through the bore. Changing the blade force does not change the chamfer size.

- Increase the blade force by turning the set screw clockwise.
- Decrease the blade force by turning the set screw counter-clockwise.

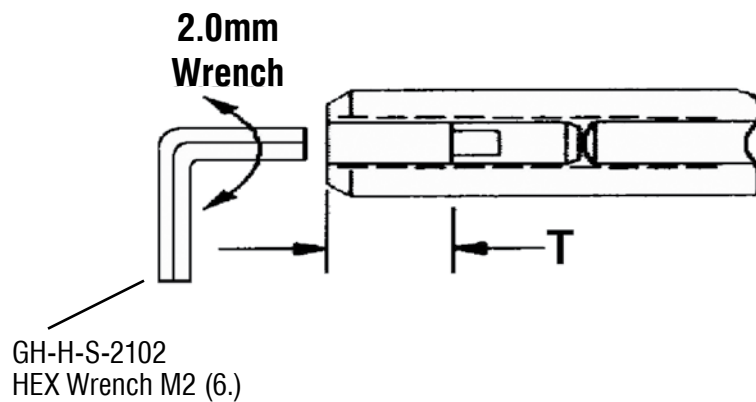

*Housing Set Screw Wrench is GH-H-S-2101 (5.)

HTC015

Programming Information

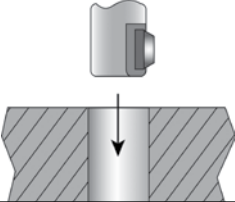
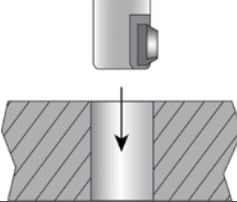
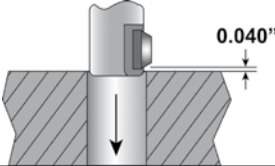
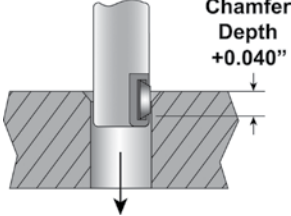
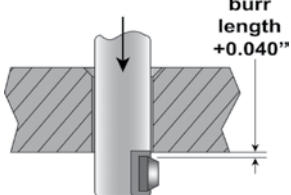
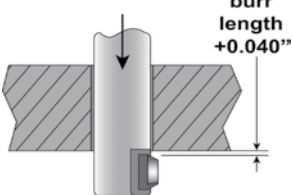
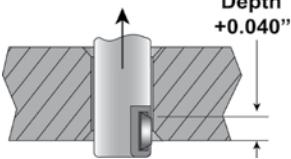
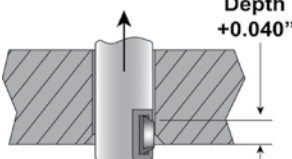
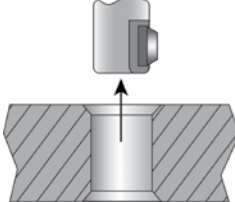
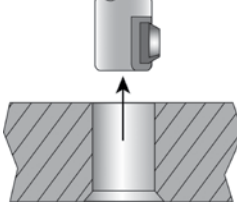
For Front & Back Chamfer		Back Chamfer Only
	<p>Step 1:</p> <p>Set the RPM according to the suggested values.</p>	
	<p>Step 2: (Move into position)</p> <p>Move the tool with rapid feed into position with the front.</p>	
	<p>Step 3: (Cut front chamfer)</p> <p>Machine the part with cutting feed (cf) and speed (cs). Feed into the part the chamfer depth + 0.040" to ensure the tool is finished cutting.</p>	
	<p>Step 4: (Rapid through part)</p> <p>Move the tool through the part with rapid feed until the blade is 0.040" beyond burr. The blade will not damage the through hole.</p>	
	<p>Step 5: (Cut back chamfer)</p> <p>Machine the part with cutting feed (cf) and speed (cs). Feed into the part the chamfer depth + 0.040" to ensure the tool is finished cutting.</p>	
	<p>Step 6: (Remove from the part)</p> <p>Remove the tool from the part with a rapid feed and proceed to the next hole. The blade will not damage the through hole.</p>	

Programming Information (continued)

Material	IPR (SNAP- GS)	IPR (SNAP- DF)	SFM
Aluminum	0.006-0.012	0.001-0.003	210-400
Brass	0.006-0.014	0.001-0.003	210-400
Low Carbon Steels	0.004-0.008	0.001-0.003	150-210
Med Carbon Steels	0.004-0.009	0.001-0.002	130-180
Free Machining Alloys	0.004-0.006	0.001-0.002	100-160
Stainless Steel	0.002-0.005	0.001-0.002	90-140
Gray Cast Iron	0.004-0.008	0.001-0.003	150-220
Nodular Cast Iron	0.003-0.007	0.001-0.002	150-220
Short Chipping Iron	0.003-0.007	0.001-0.002	100-150
Titanium	0.001-0.003	0.001-0.002	20-50

Important Note: RECOMMENDED MAXIMUM SPEED IS 6,000 RPM. Please contact Heule Tool Corporation Engineering Department for further assistance with your application.

For added stability, tool working lengths of 10mm and 20mm are available at request.



Visit our website for our full line
of product brochures and videos

www.HeuleTool.com

We provide online tool selectors for the
COFA, **SNAP**, **DEFA** and **BSF** product groups.

Simply enter your application information and the correct tool will
be provided complete with order number and sample drawing.

We are also available on:



SNAP

All Purpose Front & Back Chamfering of Through Holes

- Chamfers front and back surfaces in a single pass
- Provides high quality, consistent chamfers
- Coated carbide blades provide long tool life
- Sizes 5mm-25mm (.197"-.984") available from stock

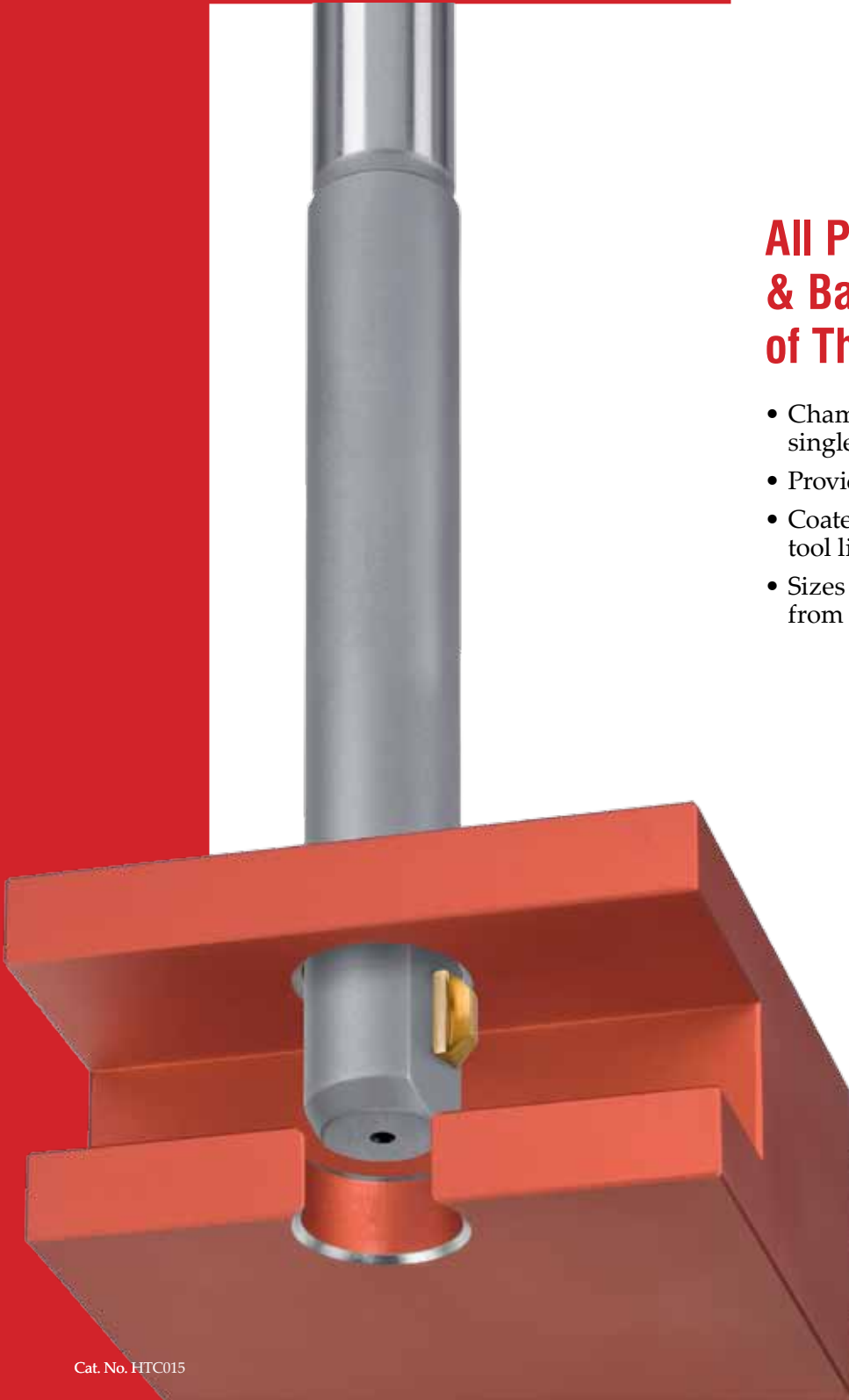

The HEULE SNAP chamfering tool is the answer for today's manufacturers requiring simpler and more flexible solutions without sacrificing quality or tool life. SNAP is a very simple tool for deburring and/or chamfering through holes on the top and bottom without reversing the spindle, dwelling, or indexing the part. The SNAP tool offers a simple to use high quality chamfering tool with Carbide inserts coated with TiN, TiCN, or TiAlN to meet today's manufacturing needs.

High Quality Consistent Chamfers

The SNAP blades are ground with a patented geometry developed by HEULE to produce quality chamfers and eliminate secondary burrs. Different chamfer sizes can be achieved by selecting a different blade. There is no need for adjustments or operator intervention. In hard materials above Rc=28, request the SNAP-DF geometry.



Long Tool Life

The solid body design of the SNAP tool provides the highest durability of any deburring tool. Additionally, the coated carbide blades give longer tool life and faster operation speeds. This durability and blade life make SNAP the ideal choice for high volume manufacturers.



Wide Range of Standard Tools

SNAP tools are available from stock from 2mm to 25mm (0.079"-0.984"). The SNAP Cassette makes it possible to deburr even larger holes quickly and efficiently and is also available from stock.

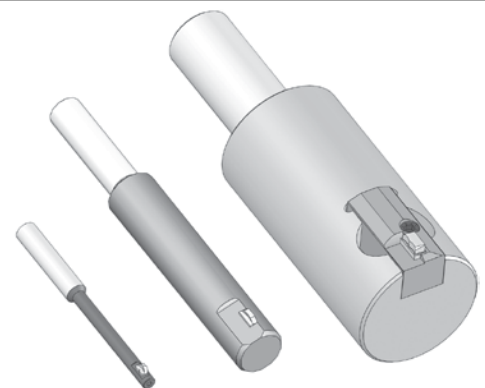

How Does It Work?

As the rotating tool is fed into the hole, the front cutting edge deburrs the top of the hole by cutting a 45° chamfer. As the tool feeds into the part, the blade is forced into the body and slides in the blade window.

When the blade is in the hole, only the ground sliding surface touches the hole protecting it from damage while the tool is fed through the part. There is no need to stop or reverse the spindle.

When the blade reaches the back of the part the coiled spring acts with the control bolt to push it back out into cutting position. The back edge is deburred and chamfered as the tool is withdrawn. When the blade is again in the hole, the tool can be rapid fed out and on the next hole.

Typical Parts

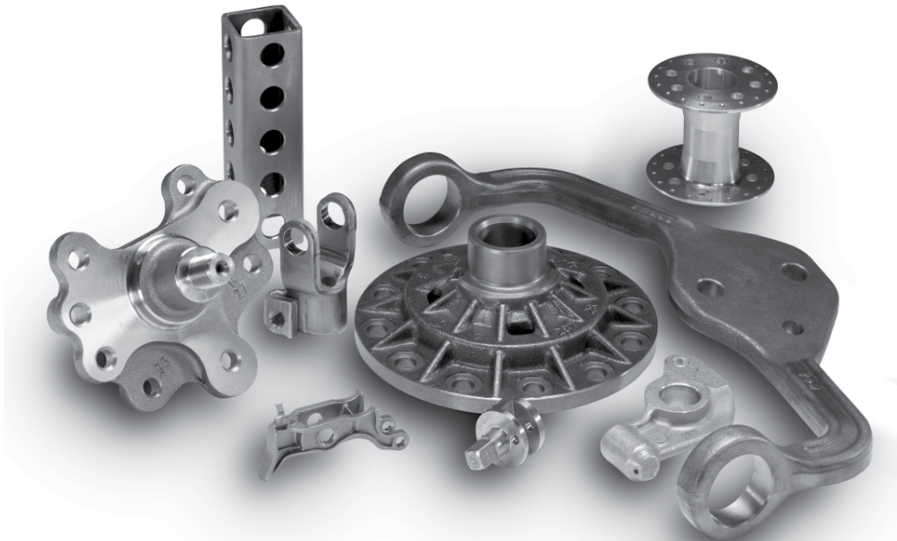

How to Select the Tool and Blade:

Selecting the proper tool is very easy and you only need to know the bore diameter and desired chamfer size. Tools are sold without blades. In most cases, there are four choices of blade sizes based on size of desired edge break. (Example: .010", .020", .030", .040" x 45°)

Sample Tool Selection

1. Use the bore size to select a tool body. Ød
 - Select the largest tool that fits the bore.
2. Use the desired chamfer size to select a blade. ØD
 - Select the proper cutting blade.

Order Example:

Bore Ø.500" / Chamfer Ø.550" (.025" x 45°)

Tool Body Order Number: SNAP12-492

Blade Order Number: GH-Q-M-03744

HTC015

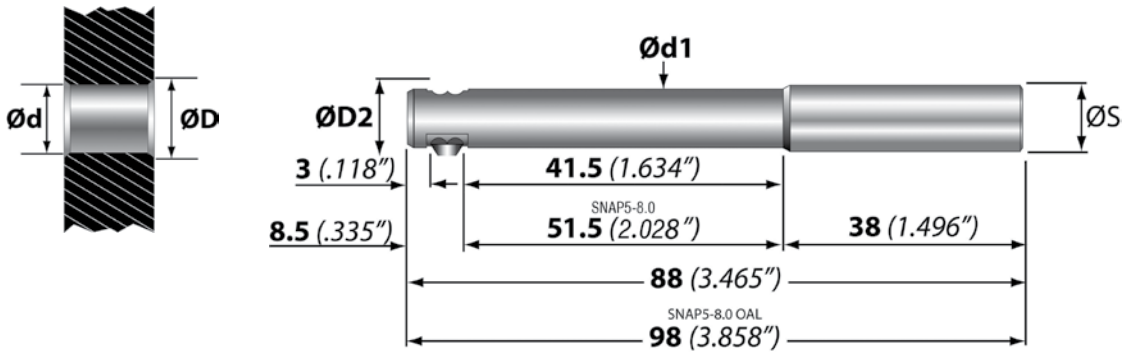

SNAP Series 5

(ØD2= ØD+0.6mm)

Minimum Hole Ø mm inches	Tool Diameter Ød1 mm inches	Tool Holder	Shank Diameter ØS mm	Blade Options* Front and Back Cutting Gs, 90°, Carbide, TiAlN GH-Q-M-_____ Chamfer ØD (mm)			
				-30204 (5.5)	-30205 (6.0)	-30206 (6.5)	-30207 (7.0)
5.0 .197	4.9 .193	SNAP5-5.0	Ø8mm	-30204 (5.5)	-30205 (6.0)	-30206 (6.5)	-30207 (7.0)
5.5 .217	5.4 .214	SNAP5-5.5	Ø8mm	-30205 (6.0)	-30206 (6.5)	-30207 (7.0)	-30208 (7.5)
6.0 .236	5.9 .232	SNAP5-6.0	Ø8mm	-30206 (6.5)	-30207 (7.0)	-30208 (7.5)	-30209 (8.0)
6.5 .256	6.4 .252	SNAP5-6.5	Ø8mm	-30207 (7.0)	-30208 (7.5)	-30209 (8.0)	-30210 (8.5)
7.0 .276	6.9 .272	SNAP5-7.0	Ø8mm	-30208 (7.5)	-30209 (8.0)	-30210 (8.5)	-30211 (9.0)
7.5 .296	7.4 .291	SNAP5-7.5	Ø8mm	-30209 (8.0)	-30210 (8.5)	-30211 (9.0)	-30212 (9.5)
8.0 .315	7.8 .307	SNAP5-8.0	Ø10mm	-30210 (8.5)	-30211 (9.0)	-30212 (9.5)	-30213 (10.0)
8.5 .335	8.3 .331	SNAP5-8.5	Ø10mm	-30211 (9.0)	-30212 (9.5)	-30213 (10.0)	-30214 (10.5)
9.0 .354	8.8 .346	SNAP5-9.0	Ø10mm	-30212 (9.5)	-30213 (10.0)	-30214 (10.5)	-30215 (11.0)
9.5 .374	9.3 .366	SNAP5-9.5	Ø10mm	-30213 (10.0)	-30214 (10.5)	-30215 (11.0)	-30216 (11.5)

* Blade sold separately

BLADE
OPTIONS PG.
73

SPARE
PARTS PG.
73

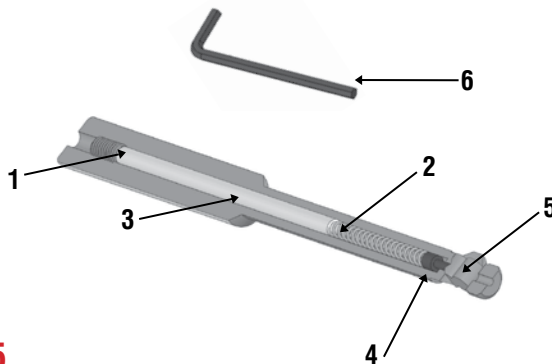

Spare Parts – SNAP 5

1	2	3	4	5	6
Set Screw	Spring	Distance Pin	Control Bolt	Blade	Wrench
GH-H-S-0127	GH-H-F-0019	GH-Q-E-0041*	GH-Q-E-0008	See Below	GH-H-S-2101

* For SNAP 5-8.0 through SNAP 5-9.5 use GH-Q-E-0068

Blades – SNAP 5 – GH-S geometry 90° angle (a = 90°)

Max. Chamfer ØD	fab TiAlN coated	bco TiAlN coated*	Dimensions	
			A	C
5.5	GH-Q-M-30204	GH-Q-M-31204	4.40	0.8
6.0	GH-Q-M-30205	GH-Q-M-31205	4.65	1.3
6.5	GH-Q-M-30206	GH-Q-M-31206	4.70	1.6
7.0	GH-Q-M-30207	GH-Q-M-31207	4.85	1.6
7.5	GH-Q-M-30208	GH-Q-M-31208	5.20	1.6
8.0	GH-Q-M-30209	GH-Q-M-31209	5.70	1.7
8.5	GH-Q-M-30210	GH-Q-M-31210	5.80	1.7
9.0	GH-Q-M-30211	GH-Q-M-31211	6.30	1.7
9.5	GH-Q-M-30212	GH-Q-M-31212	6.80	1.7
10.0	GH-Q-M-30213	GH-Q-M-31213	7.30	1.7
10.5	GH-Q-M-30214	GH-Q-M-31214	7.80	1.7
11.0	GH-Q-M-30215	GH-Q-M-31215	7.80	1.8
11.5	GH-Q-M-30216	GH-Q-M-31216	8.05	1.8
12.0	GH-Q-M-30217	GH-Q-M-31217	8.30	1.8
12.5	GH-Q-M-30218	GH-Q-M-31218	8.55	1.8
13.0	GH-Q-M-30219	GH-Q-M-31219	8.80	1.8

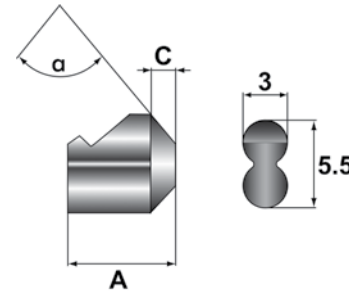

* Non-stock standard item with extended delivery time

PROGRAMMING PG. 88-89

CHANGE BLADES PG. 87

HTC015

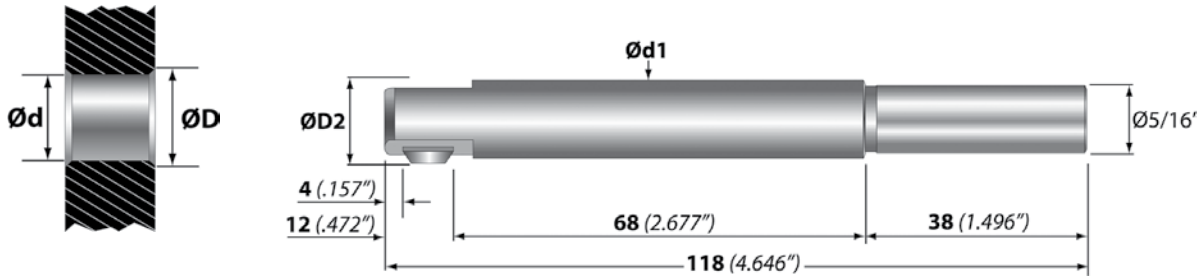

SNAP Series 8

(ØD2= ØD+0.8mm)

Minimum Hole Ø mm inches	Tool Diameter Ød1 mm inches	Tool Holder	Blade Options* Front and Back Cutting Gs, 90°, Carbide, TiN GH-Q-M-_____ Chamfer ØD (mm)		
			-03720 (8.5)	-03721 (9.0)	-03722 (9.5)
8.0 .315	7.8 .307	SNAP8-315	-03720 (8.5)	-03721 (9.0)	-03722 (9.5)
8.5 .335	8.3 .327	SNAP8-335	-03721 (9.0)	-03722 (9.5)	-03723 (10.0)
9.0 .354	8.8 .346	SNAP8-354	-03722 (9.5)	-03723 (10.0)	-03724 (10.5)
9.5 .374	9.3 .366	SNAP8-374	-03723 (10.0)	-03724 (10.5)	-03725 (11.0)
10.0 .394	9.8 .386	SNAP8-394	-03724 (10.5)	-03725 (11.0)	-03726 (11.5)
10.5 .413	10.3 .406	SNAP8-413	-03725 (11.0)	-03726 (11.5)	-03727 (12.0)
11.0 .433	10.8 .425	SNAP8-433	-03726 (11.5)	-03727 (12.0)	-03728 (12.5)
11.5 .453	11.3 .445	SNAP8-453	-03727 (12.0)	-03728 (12.5)	-03729 (13.0)
12.0 .472	11.8 .465	SNAP8-472	-03728 (12.5)	-03729 (13.0)	-03730 (13.5)

* Blade sold separately

BLADE
OPTIONS PG.
85

SPARE
PARTS PG.
75

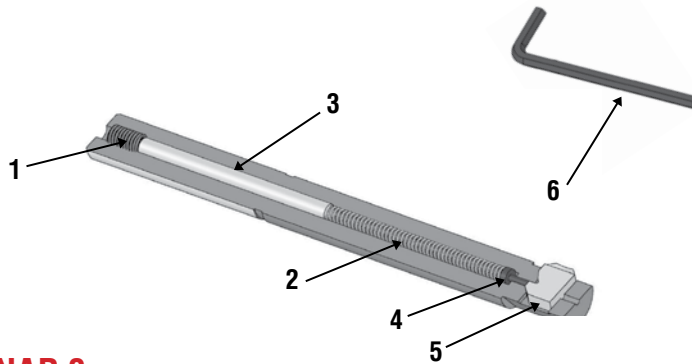

Spare Parts – SNAP 8

1	2	3	4	5	6
Set Screw	Spring	Distance Pin	Control Bolt	Blade	Wrench
GH-H-S-0119	GH-H-F-0007	GH-Q-E-0028	GH-Q-E-0002	See Below	GH-H-S-2100

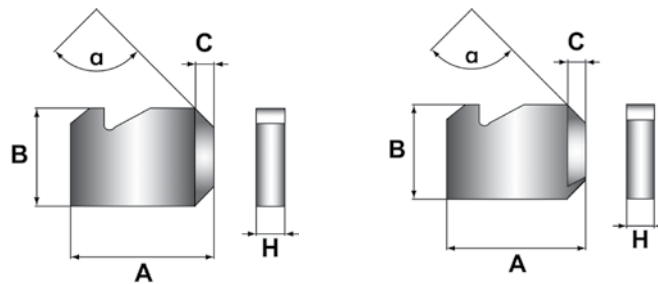

Blades – SNAP 8 – GH-S geometry 90° angle

(a = 90°)

Max. Chamfer ØD	fab TiN coated	bco TiN coated*	Dimensions			
			A	B	C	H
8.5	GH-Q-M-03720	GH-Q-M-05720	7.5	8.0	1.2	2.0
9.0	GH-Q-M-03721	GH-Q-M-05721	7.6	8.0	1.4	2.0
9.5	GH-Q-M-03722	GH-Q-M-05722	8.0	8.0	1.6	2.0
10.0	GH-Q-M-03723	GH-Q-M-05723	8.1	8.0	1.6	2.0
10.5	GH-Q-M-03724	GH-Q-M-05724	8.5	8.0	1.6	2.0
11.0	GH-Q-M-03725	GH-Q-M-05725	8.6	8.0	1.8	2.0
11.5	GH-Q-M-03726	GH-Q-M-05726	9.0	8.0	1.8	2.0
12.0	GH-Q-M-03727	GH-Q-M-05727	9.4	8.0	1.8	2.0
12.5	GH-Q-M-03728	GH-Q-M-05728	9.8	8.0	1.8	2.0
13.0	GH-Q-M-03729	GH-Q-M-05729	10.2	8.0	1.8	2.0
13.5	GH-Q-M-03730	GH-Q-M-05730	10.5	8.0	1.8	2.0

* Non-stock standard item with extended delivery time

PROGRAMMING PG. 88-89

CHANGE BLADES PG. 87

HTC015

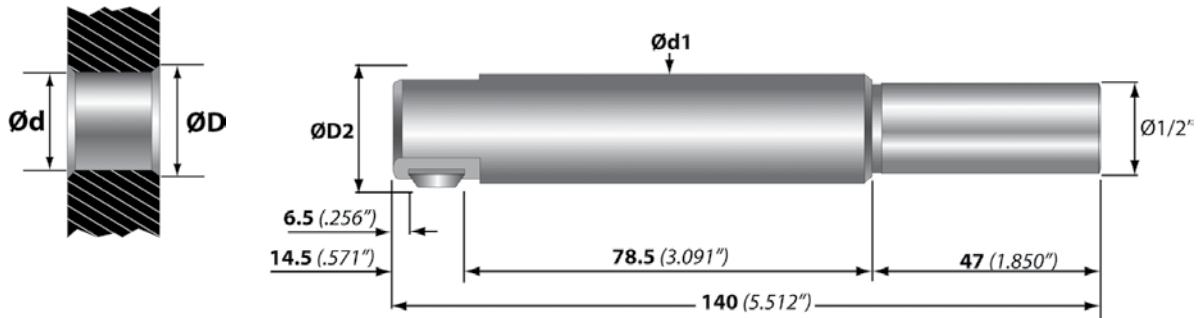

SNAP Series 12

(ØD2 = ØD + 0.8mm)

Minimum Hole Ø mm inches	Tool Diameter Ød1 mm inches	Tool Holder	Blade Options* Front and Back Cutting Gs, 90°, Carbide, TiN GH-Q-M-_____ Chamfer ØD (mm)			
			-03740 (12.5)	-03741 (13.0)	-03742 (13.5)	-03743 (14.0)
12.0 .473	11.8 .465	SNAP12-473	-03740 (12.5)	-03741 (13.0)	-03742 (13.5)	-03743 (14.0)
12.5 .492	12.3 .484	SNAP12-492	-03741 (13.0)	-03742 (13.5)	-03743 (14.0)	-03744 (14.5)
13.0 .512	12.8 .504	SNAP12-512	-03742 (13.5)	-03743 (14.0)	-03744 (14.5)	-03745 (15.0)
13.5 .531	13.3 .524	SNAP12-531	-03743 (14.0)	-03744 (14.5)	-03745 (15.0)	-03746 (15.5)
14.0 .551	13.8 .543	SNAP12-551	-03744 (14.5)	-03745 (15.0)	-03746 (15.5)	-03747 (16.0)
14.5 .571	14.3 .563	SNAP12-571	-03745 (15.0)	-03746 (15.5)	-03747 (16.0)	-03748 (16.5)
15.0 .591	14.8 .583	SNAP12-591	-03746 (15.5)	-03747 (16.0)	-03748 (16.5)	-03749 (17.0)
15.5 .610	15.3 .602	SNAP12-610	-03747 (16.0)	-03748 (16.5)	-03749 (17.0)	-03750 (17.5)
16.0 .630	15.8 .622	SNAP12-630	-03748 (16.5)	-03749 (17.0)	-03750 (17.5)	-03751 (18.0)
16.5 .650	16.3 .642	SNAP12-650	-03749 (17.0)	-03750 (17.5)	-03751 (18.0)	-03752 (18.5)
17.0 .669	16.8 .661	SNAP12-669	-03750 (17.5)	-03751 (18.0)	-03752 (18.5)	-03753 (19.0)
17.5 .689	17.3 .681	SNAP12-689	-03751 (18.0)	-03752 (18.5)	-03753 (19.0)	-03754 (19.5)
18.0 .709	17.8 .701	SNAP12-709	-03752 (18.5)	-03753 (19.0)	-03754 (19.5)	-03755 (20.0)
18.5 .729	18.3 .720	SNAP12-729	-03753 (19.0)	-03754 (19.5)	-03755 (20.0)	-03756 (20.5)
19.0 .748	18.8 .740	SNAP12-748	-03754 (19.5)	-03755 (20.0)	-03756 (20.5)	-03757 (21.0)
19.5 .768	19.3 .760	SNAP12-768	-03755 (20.0)	-03756 (20.5)	-03757 (21.0)	-03758 (21.5)
20.0 .787	19.8 .780	SNAP12-787	-03756 (20.5)	-03757 (21.0)	-03758 (21.5)	-03759 (22.0)

* Blade sold separately

BLADE
OPTIONS PG.
86

SPARE
PARTS PG.
77

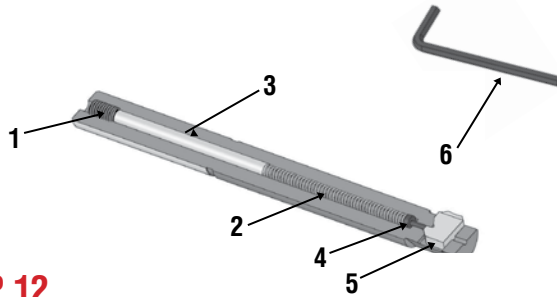

Spare Parts – SNAP 12

1	2	3	4	5	6
Set Screw	Spring	Distance Pin	Control Bolt	Blade	Wrench
GH-H-S-0119	GH-H-F-0007	GH-Q-E-0032	GH-Q-E-0002	See Below	GH-H-S-2100

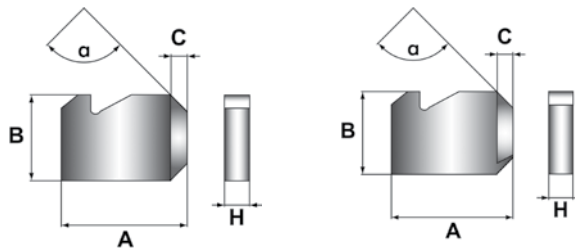

Blades – SNAP 12 – GH-S geometry 90° angle

(a = 90°)

Max. Chamfer ØD	fab TiN coated	bco TiN coated*	Dimensions			
			A	B	C	H
12.5	GH-Q-M-03740	GH-Q-M-05740	10.5	8.0	1.5	3.0
13.0	GH-Q-M-03741	GH-Q-M-05741	10.7	8.0	1.8	3.0
13.5	GH-Q-M-03742	GH-Q-M-05742	11.0	8.0	1.8	3.0
14.0	GH-Q-M-03743	GH-Q-M-05743	11.5	8.0	1.8	3.0
14.5	GH-Q-M-03744	GH-Q-M-05744	12.0	8.0	1.8	3.0
15.0	GH-Q-M-03745	GH-Q-M-05745	12.5	8.0	1.8	3.0
15.5	GH-Q-M-03746	GH-Q-M-05746	12.8	8.0	1.8	3.0
16.0	GH-Q-M-03747	GH-Q-M-05747	13.0	8.0	1.8	3.0
16.5	GH-Q-M-03748	GH-Q-M-05748	13.2	8.0	1.8	3.0
17.0	GH-Q-M-03749	GH-Q-M-05749	13.6	8.0	1.8	3.0
17.5	GH-Q-M-03750	GH-Q-M-05750	14.0	8.0	1.8	3.0
18.0	GH-Q-M-03751	GH-Q-M-05751	14.2	8.0	1.8	3.0
18.5	GH-Q-M-03752	GH-Q-M-05752	14.5	8.0	1.8	3.0
19.0	GH-Q-M-03753	GH-Q-M-05753	14.8	8.0	1.8	3.0
19.5	GH-Q-M-03754	GH-Q-M-05754	15.0	8.0	1.8	3.0
20.0	GH-Q-M-03755	GH-Q-M-05755	15.4	8.0	1.8	3.0
20.5	GH-Q-M-03756	GH-Q-M-05756	15.6	8.0	1.8	3.0
21.0	GH-Q-M-03757	GH-Q-M-05757	16.0	8.0	1.8	3.0
21.5	GH-Q-M-03758	GH-Q-M-05758	16.4	8.0	1.8	3.0
22.0	GH-Q-M-03759	GH-Q-M-05759	16.6	8.0	1.8	3.0

* Non-stock standard item with extended delivery time



HTC015

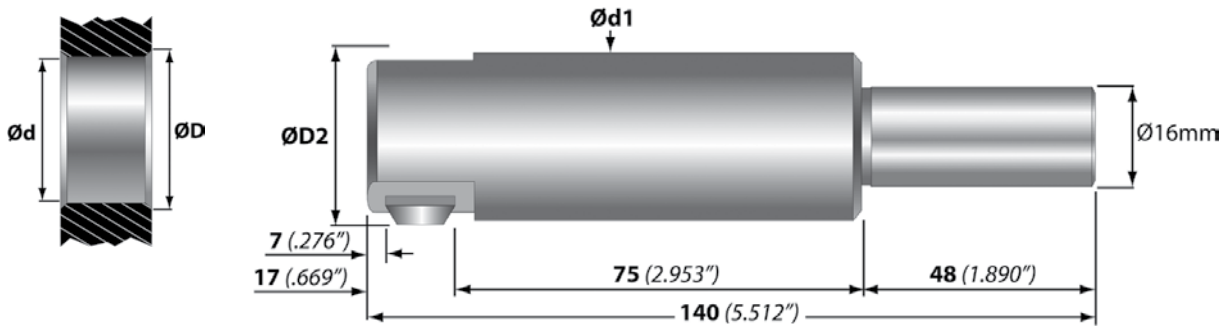

SNAP Series 20

($\text{ØD2} = \text{ØD} + 0.8\text{mm}$)

Minimum Hole Ø mm inches	Tool Diameter Ød1 mm inches	Tool Holder*	Blade Options* Front and Back Cutting Gs,90°, Carbide, TiN and Chamfer ØD (mm)		
			GH-Q-M-		
20.0 .787	19.8 .780	SNAP20-20.0	-03770 (21.0)	-03771 (22.0)	-03772 (23.0)
21.0 .827	20.8 .819	SNAP20-21.0	-03771 (22.0)	-03772 (23.0)	-03773 (24.0)
22.0 .866	21.8 .858	SNAP20-22.0	-03772 (23.0)	-03773 (24.0)	-03774 (25.0)
23.0 .906	22.8 .898	SNAP20-23.0	-03773 (24.0)	-03774 (25.0)	-03775 (26.0)
24.0 .945	23.8 .937	SNAP20-24.0	-03774 (25.0)	-03775 (26.0)	-03776 (27.0)
25.0 .984	24.8 .976	SNAP20-25.0	-03775 (26.0)	-03776 (27.0)	-03777 (28.0)
26.0 1.024	25.8 1.016	SNAP20-26.0	-03776 (27.0)	-03777 (28.0)	-03778 (29.0)
27.0 1.063	26.8 1.055	SNAP20-27.0	-03777 (28.0)	-03778 (29.0)	-03779 (30.0)
28.0 1.102	27.8 1.094	SNAP20-28.0	-03778 (29.0)	-03779 (30.0)	-03780 (31.0)
29.0 1.142	28.8 1.134	SNAP20-29.0	-03779 (30.0)	-03780 (31.0)	-03781 (32.0)
30.0 1.181	29.8 1.173	SNAP20-30.0	-03780 (31.0)	-03781 (32.0)	-03782 (33.0)
31.0 1.220	30.8 1.213	SNAP20-31.0	-03781 (32.0)	-03782 (33.0)	-03783 (34.0)
32.0 1.260	31.8 1.252	SNAP20-32.0	-03782 (33.0)	-03783 (34.0)	-03784 (35.0)
33.0 1.299	32.8 1.291	SNAP20-33.0	-03783 (34.0)	-03784 (35.0)	-03785 (36.0)
34.0 1.339	33.8 1.331	SNAP20-34.0	-03784 (35.0)	-03785 (36.0)	-03786 (37.0)
35.0 1.378	34.8 1.370	SNAP20-35.0	-03785 (36.0)	-03786 (37.0)	-03787 (38.0)

* Blade sold separately

* Non-stock standard item with extended delivery time

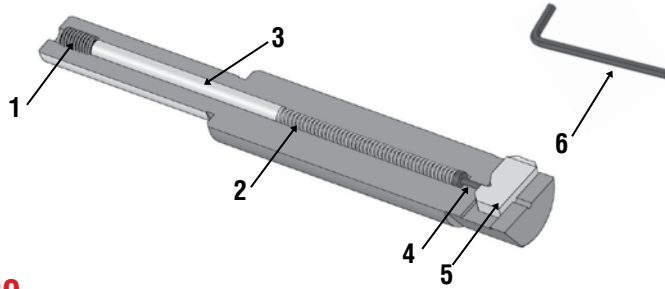

Spare Parts – SNAP 20

1	2	3	4	5	6
Set Screw	Spring	Distance Pin	Control Bolt	Blade	Wrench
GH-H-S-0119	GH-H-F-0011	GH-Q-E-0031	GH-Q-E-0003	See Table	GH-H-S-2100

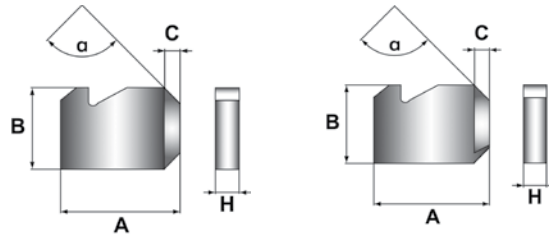

Blades – SNAP 20 – GH-S geometry 90° angle

(a = 90°)

Max. Chamfer ØD	fab TiN coated	bco TiN coated*	Dimensions			
			A	B	C	H
21.0	GH-Q-M-03770	GH-Q-M-05770	17.0	10.0	2.5	5.0
22.0	GH-Q-M-03771	GH-Q-M-05771	17.5	10.0	2.5	5.0
23.0	GH-Q-M-03772	GH-Q-M-05772	18.0	10.0	2.5	5.0
24.0	GH-Q-M-03773	GH-Q-M-05773	18.5	10.0	2.5	5.0
25.0	GH-Q-M-03774	GH-Q-M-05774	20.0	10.0	2.5	5.0
26.0	GH-Q-M-03775	GH-Q-M-05775	20.5	10.0	2.5	5.0
27.0	GH-Q-M-03776	GH-Q-M-05776	21.0	10.0	2.5	5.0
28.0	GH-Q-M-03777	GH-Q-M-05777	21.5	10.0	2.5	5.0
29.0	GH-Q-M-03778	GH-Q-M-05778	22.0	10.0	2.5	5.0
30.0	GH-Q-M-03779	GH-Q-M-05779	23.5	10.0	2.5	5.0
31.0	GH-Q-M-03780	GH-Q-M-05780	24.0	10.0	2.5	5.0
32.0	GH-Q-M-03781	GH-Q-M-05781	24.5	10.0	2.5	5.0
33.0	GH-Q-M-03782	GH-Q-M-05782	25.0	10.0	2.5	5.0
34.0	GH-Q-M-03783	GH-Q-M-05783	25.5	10.0	2.5	5.0
35.0	GH-Q-M-03784	GH-Q-M-05784	27.0	10.0	2.5	5.0
36.0	GH-Q-M-03785	GH-Q-M-05785	27.5	10.0	2.5	5.0
37.0	GH-Q-M-03786	GH-Q-M-05786	28.0	10.0	2.5	5.0
38.0	GH-Q-M-03787	GH-Q-M-05787	28.5	10.0	2.5	5.0

* Non-stock standard item with extended delivery time

PROGRAMMING PG. 88-89

CHANGE BLADES PG. 87

SNAP 5 “Slim Line” Cassette

Easy Incorporation with Various Multi-Tasking Tools while Producing Quality Front & Back Chamfers

New SNAP 5 “Slim Line” Cassette with GS geometry cutting blade. The SNAP 5 Cassette is the smallest standard cassette Heule makes, measuring 5mm thick and 30mm long.

The advantage of the “Slim Line” SNAP 5 Cassette is it can easily be incorporated into various multi-tasking tools, including drills, boring tools and other state of the art technology.

The benefits are using Heule’s quality front and back chamfer system with the industry’s best hole making technology.

The part number for the cassette is **GH-Q-0-1430**.



SNAP Cassette

	Reference
Ød	Hole Diameter
ØD2	Over Blade Dia.
ØD	Chamfer Diameter
Ød1	Tool Diameter
x	Offset from Center

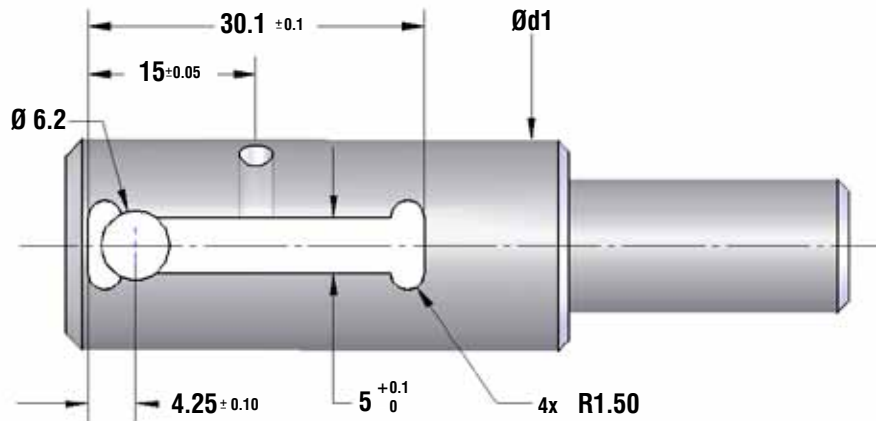
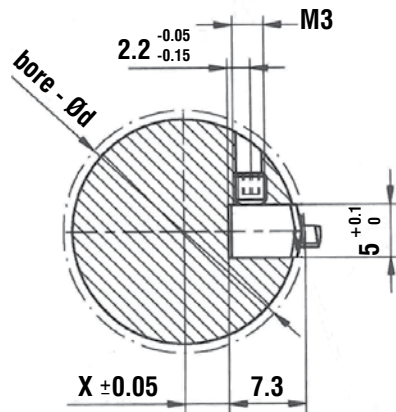

Minimum Bore Ød	Maximum Chamfer ØDmax	Maximum Tool Diameter Ød1	Calc. of the “X” offset
20mm - 80mm (Specials on request down to Ø12.6mm)	$\text{ØDmax} = \text{Ød} + 2$	$\text{Max } \text{Ød1} = \text{Bore } \text{Ød} - 0.5\text{mm}$	$X = \frac{\text{BORE Dia } (\text{Ød})}{2} - 7.3\text{mm}$

BLADE OPTIONS **PG. 81**

SPARE PARTS **PG. 81**

Blade Options: SNAP 5 Cassette

Blades are available from stock as front and back cutting (fab) or back only cutting (bco).

GS Geometry 90° Carb-TiAlN

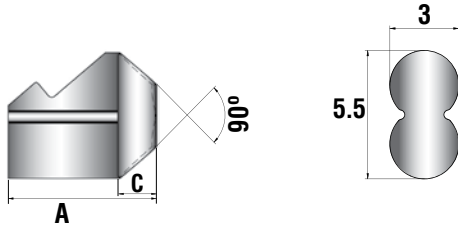

Chamfer	Front & Back GH-Q-M-	Back Only GH-Q-M-	A	C
0.5 x 45°	-30770	-31770	6.15	1.25
1.0 x 45°	-30771	-31771	6.6	1.8

DF Geometry 90° Carbide-TiAlN

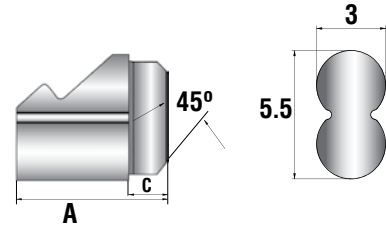

Chamfer	Front & Back GH-Q-M-	Back Only GH-Q-M-	A	C
0.5 x 90°	-30780*	-31780*	6.3	1.3
1.0 x 90°	-30781*	-31781*	6.8	1.8

*Extended delivery

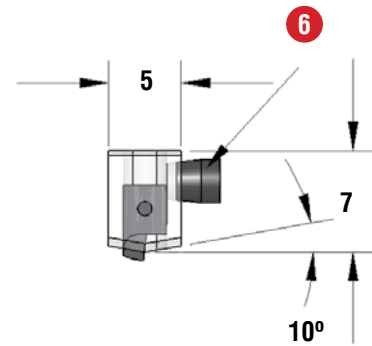
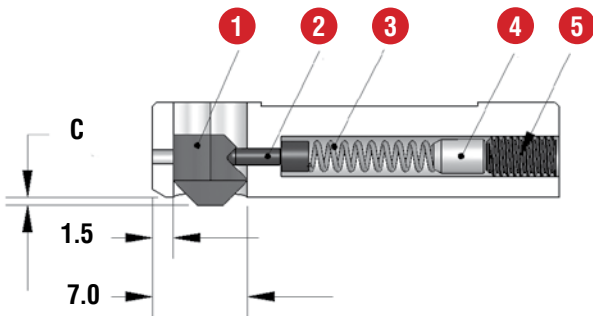

Spare Parts – SNAP 5 CASS; Order Number Complete GH-Q-0-1430*

1	2	3	4	5	6
Blade*	Bolt	Spring	Distance Pin	Screw	Set Screw
See Above	GH-Q-E-0008	GH-H-F-0027	GH-H-Q-E-0046	GH-H-S-0127	GH-H-S-0355

*Blade sold separately.

PROGRAMMING PG. 88-89

CHANGE BLADES PG. 87

HTC015

SNAP 35 Cassette

Large Bore Chamfering and Multi-Tasking is easy with Heule's SNAP Cassette

The SNAP 35 Cassette makes it possible to deburr larger holes quickly and efficiently and is also available from stock.

New blade options include both DF and GS geometries. Large chamfer up to .060" (1.5mm) is possible. Use DF geometry for materials above 28Rc.

The part number for the cassette is **GH-Q-0-1030**.

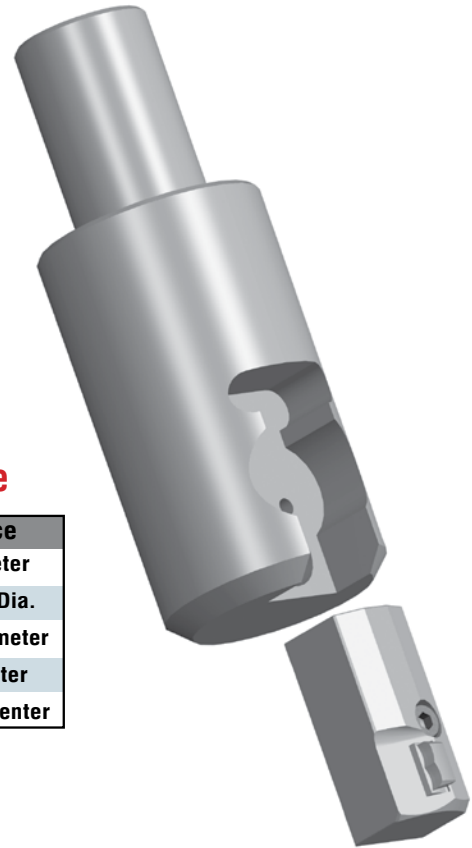

SNAP Cassette

	Reference
Ød	Hole Diameter
ØD2	Over Blade Dia.
ØD	Chamfer Diameter
Ød1	Tool Diameter
x	Offset from Center

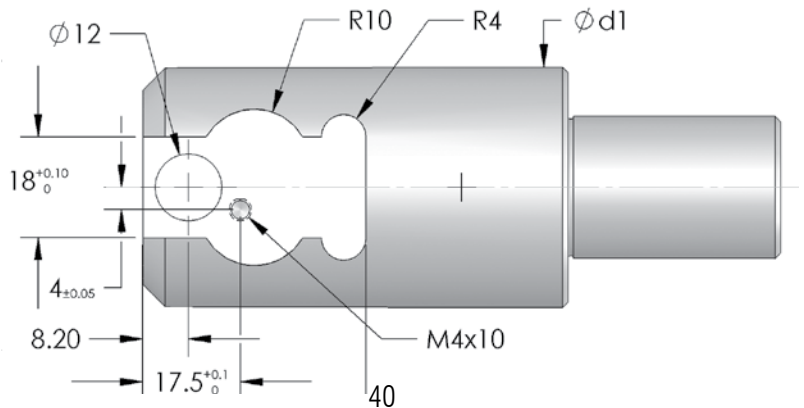
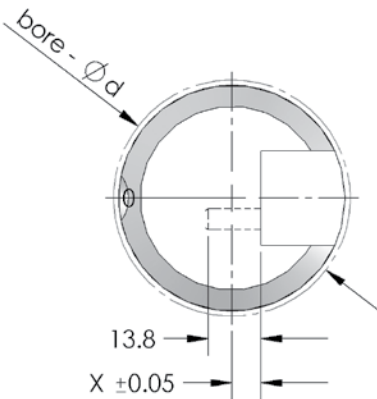

Minimum Bore Ød	Maximum Chamfer ØDmax	Maximum Tool Diameter Ød1	Calc. of the "X" offset
35mm	$\text{ØDmax} = \text{Ød} + 3.0$	$\text{Max } \text{Ød1} = \text{Bore } \text{Ød} - 2.0\text{mm}$	$X = \frac{\text{BORE Dia } (\text{Ød})}{2} - 17.0\text{mm}$

BLADE
OPTIONS **PG. 83**

SPARE
PARTS **PG. 83**

Blade Options: Cassette Series 35:

Blades are available from stock as front and back cutting (**fab**) or back cutting only (**bco**).

SNAP DEFA Front & Back

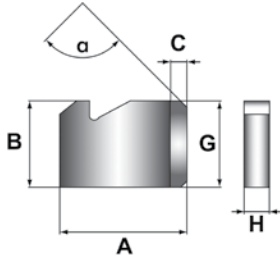

SNAP DEFA Back Only

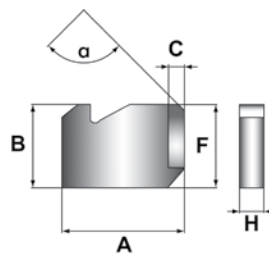

SNAP GS Front & Back

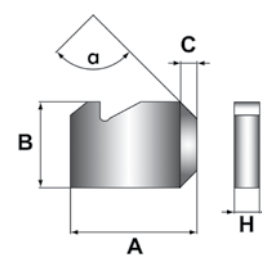

Maximum Chamfer	Dimensions					DEFA front and back cutting 90° Carb-TiN	DEFA back cutting only 90° Carb-TiN	GS front and back cutting 90° Carb-TiAlN
	A	B	F	G	H			
0.5 0.020	16 0.630	10 0.394	9.5 0.374	9.0 0.354	5.0 0.197	GH-Q-M-01901	GH-Q-M-01921	GH-Q-M-01802
1.0 0.039	16.5 0.650	10 0.394	9.5 0.374	9.0 0.354	5.0 0.197	GH-Q-M-01904	GH-Q-M-01924	GH-Q-M-01812
1.5 0.059	16.5 0.650	10 0.394	9.5 0.374	9.0 0.354	5.0 0.197	GH-Q-M-01907	GH-Q-M-01927	GH-Q-M-01822

*Note: GS chamfer range can vary more than DF geometry.

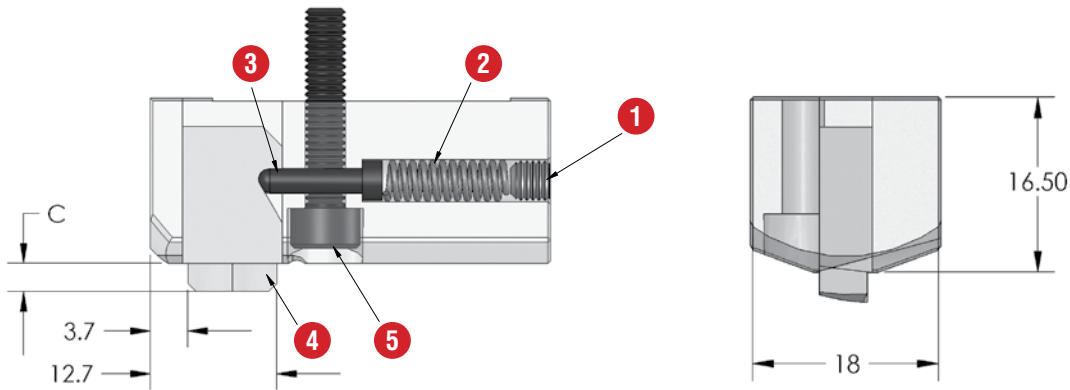

Spare Parts – Cassette

	1	2	3	4	5
Cassette	Set Screw	Spring	Control Bolt	Blade	Cap Screw
Series 35	GH-H-S-0120	GH-H-F-0012	GH-Q-E-0003	See Above	GH-H-S-0502

PROGRAMMING PG. 88-89

CHANGE BLADES PG. 87

HTC015

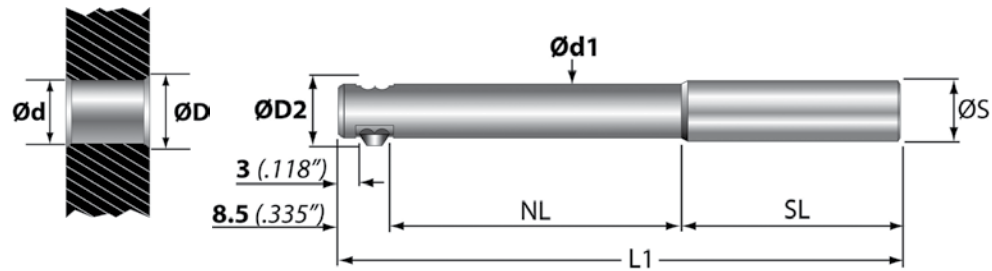

SNAP Tooling for Common Tap Holes

SNAP Deburring Series 5											$\text{ØD2} = \text{ØD} + 0.6\text{mm}$	
For holes 5mm-8mm (0.197" through .315")											$\text{Ød1} + 0 / - .002"$	
Tap/Pitch	Drill $+0.1$ -0		Order Number	Tool Dia.				Shank ØS	Blade**, Carbide-TiAlN, 90°, fab			
	mm	inches		Ød1	L1	NL	SL		Chamfer (ØD) ¹		Order Number	
			mm	mm	mm	mm	mm	mm	mm	inches		
M6-1.0	5.0	(.197)	SNAP5-5.0	4.9	88	41.5	38	Ø8	6.5	(.256)	GH-Q-M-30206	
1/4"-20	5.11	(.201)	SNAP5-5.0	4.9	88	41.5	38	Ø8	7.0	(.276)	GH-Q-M-30207	
M7-1.0	6.0	(.236)	SNAP5-6.0	5.9	88	41.5	38	Ø8	7.5	(.295)	GH-Q-M-30208	
5/16"-18	6.53	(.257)	SNAP5-6.5	6.4	88	40	38	Ø8	8.5	(.335)	GH-Q-M-30210	
M8-1.25	6.7	(.264)	SNAP5-6.5	6.4	88	40	38	Ø8	8.5	(.335)	GH-Q-M-30210	
3/8"-16	7.9	(.311)	SNAP5-7.5	7.4	88	40	38	Ø8	10.0	(.394)	GH-Q-M-30213	

SNAP Deburring Series 5 Extended Range											$\text{ØD2} = \text{ØD} + 0.6\text{mm}$	
For holes 8mm-10.5mm (0.316" through .500")											$\text{Ød1} + 0 / - .002"$	
Tap/Pitch	Drill $+0.1$ -0		Order Number	Tool Dia.				Shank ØS	Blade**, Carbide-TiAlN, 90°, fab			
	mm	inches		Ød1	L1	NL	SL		Chamfer (ØD) ¹		Order Number	
			mm	mm	mm	mm	mm	mm	mm	inches		
M10-1.5	8.4	(.331)	SNAP5-8.0	7.9	98	51.5	38	Ø10	10.5	(.413)	GH-Q-M-30214	
M10-1.25	8.75	(.344)	SNAP5-8.5	8.4	98	51.5	38	Ø10	11.0	(.433)	GH-Q-M-30215	
7/16"-14	9.35	(.368)	SNAP5-9.0	8.8	98	51.5	38	Ø10	11.5	(.453)	GH-Q-M-30216	
7/16"-20	9.92	(.391)	SNAP5-9.5	9.3	98	51.5	38	Ø10	12.0	(.472)	GH-Q-M-30217	
M12-1.75	10.3	(.406)	SNAP5-10.0*	9.8	107	51.5	47	Ø12	12.5	(.492)	GH-Q-M-30218	
1/2"-13	10.7	(.421)	SNAP5-10.5*	10.3	107	51.5	47	Ø12	13.0	(.512)	GH-Q-M-30219	

¹ Attainable chamfer size depends on material, blade force and feed rate. Not recommended for materials above 28Rc

*Non-stock standard item with extended delivery time

**Blade sold separately

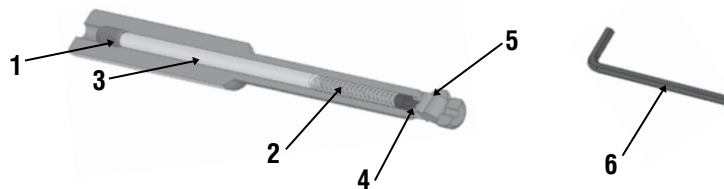

Spare Parts

	1	2	3	4	5	6
Order Number	Set Screw	Spring	Distance Pin	Control Bolt	Blade	Wrench
SNAP5-5.0-7.5	GH-H-S-0127	GH-H-F-0019	GH-Q-E-0041	GH-Q-E-0008	See Above	GH-H-S-2101
SNAP5-8.0-9.0	GH-H-S-0127	GH-H-F-0019	GH-Q-E-0068	GH-Q-E-0008	See Above	GH-H-S-2101
SNAP5-10.0-10.5	GH-H-S-0127	GH-H-F-0019	GH-Q-E-0067	GH-Q-E-0008	See Above	GH-H-S-2101

PROGRAMMING **PG. 88-89**

CHANGE BLADES **PG. 87**

BLADE OPTIONS **PG. 73**

Front & Back Chamfering

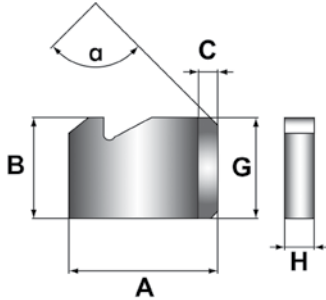

Back Only Chamfering

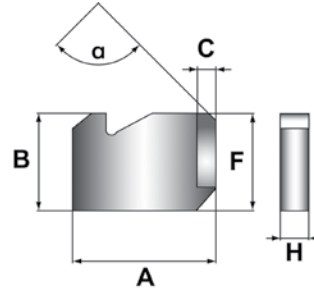

SNAP 8 – DEFA Geometry 90° angle*

(a = 90°)

Max. Chamfer	fab TiN coated	bco TiN coated	Dimensions					
			A	B	C	G	H	F
8.5	GH-Q-M-03120	GH-Q-M-05120	7.5	8.0	1.2	7.2	2.0	7.6
9.0	GH-Q-M-03121	GH-Q-M-05121	7.6	8.0	1.4	7.2	2.0	7.6
9.5	GH-Q-M-03122	GH-Q-M-05122	8.0	8.0	1.6	7.2	2.0	7.6
10.0	GH-Q-M-03123	GH-Q-M-05123	8.1	8.0	1.6	7.2	2.0	7.6
10.5	GH-Q-M-03124	GH-Q-M-05124	8.5	8.0	1.6	7.2	2.0	7.6
11.0	GH-Q-M-03125	GH-Q-M-05125	8.6	8.0	1.8	7.2	2.0	7.6
11.5	GH-Q-M-03126	GH-Q-M-05126	9.0	8.0	1.8	7.2	2.0	7.6
12.0	GH-Q-M-03127	GH-Q-M-05127	9.4	8.0	1.8	7.2	2.0	7.6
12.5	GH-Q-M-03128	GH-Q-M-05128	9.8	8.0	1.8	7.2	2.0	7.6
13.0	GH-Q-M-03129	GH-Q-M-05129	10.2	8.0	1.8	7.2	2.0	7.6
13.5	GH-Q-M-03130	GH-Q-M-05130	10.5	8.0	1.8	7.2	2.0	7.6

SNAP Blade Options

There are different blade options for the SNAP tool if an application requires a different chamfer than the standard 90° blade. The 60° blades offer a 60° angled chamfer instead of the standard 90° angled chamfer while the DEFA geometry blades provide precision chamfering and handles larger burr formation.

HTC015

Front & Back Chamfering

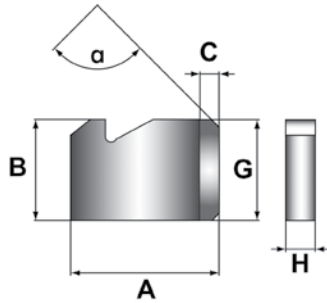

Back Only Chamfering

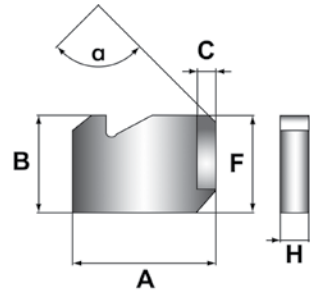

SNAP 12 – DEFA Geometry 90° angle*

(a = 90°)

Max. Chamfer	fab TiN coated	bco TiN coated	Dimensions					
			A	B	C	G	H	F
12.5	GH-Q-M-03140	GH-Q-M-05140	10.5	8.0	1.5	7.2	3.0	7.6
13.0	GH-Q-M-03141	GH-Q-M-05141	10.7	8.0	1.8	7.2	3.0	7.6
13.5	GH-Q-M-03142	GH-Q-M-05142	11.0	8.0	1.8	7.2	3.0	7.6
14.0	GH-Q-M-03143	GH-Q-M-05143	11.5	8.0	1.8	7.2	3.0	7.6
14.5	GH-Q-M-03144	GH-Q-M-05144	12.0	8.0	1.8	7.2	3.0	7.6
15.0	GH-Q-M-03145	GH-Q-M-05145	12.5	8.0	1.8	7.2	3.0	7.6
15.5	GH-Q-M-03146	GH-Q-M-05146	12.8	8.0	1.8	7.2	3.0	7.6
16.0	GH-Q-M-03147	GH-Q-M-05147	13.0	8.0	1.8	7.2	3.0	7.6
16.5	GH-Q-M-03148	GH-Q-M-05148	13.2	8.0	1.8	7.2	3.0	7.6
17.0	GH-Q-M-03149	GH-Q-M-05149	13.6	8.0	1.8	7.2	3.0	7.6
17.5	GH-Q-M-03150	GH-Q-M-05150	14.0	8.0	1.8	7.2	3.0	7.6
18.0	GH-Q-M-03151	GH-Q-M-05151	14.2	8.0	1.8	7.2	3.0	7.6
18.5	GH-Q-M-03152	GH-Q-M-05152	14.5	8.0	1.8	7.2	3.0	7.6
19.0	GH-Q-M-03153	GH-Q-M-05153	14.8	8.0	1.8	7.2	3.0	7.6
19.5	GH-Q-M-03154	GH-Q-M-05154	15.0	8.0	1.8	7.2	3.0	7.6
20.0	GH-Q-M-03155	GH-Q-M-05155	15.4	8.0	1.8	7.2	3.0	7.6
20.5	GH-Q-M-03156	GH-Q-M-05156	15.6	8.0	1.8	7.2	3.0	7.6
21.0	GH-Q-M-03157	GH-Q-M-05157	16.0	8.0	1.8	7.2	3.0	7.6
21.5	GH-Q-M-03158	GH-Q-M-05158	16.4	8.0	1.8	7.2	3.0	7.6
22.0	GH-Q-M-03159	GH-Q-M-05159	16.6	8.0	1.8	7.2	3.0	7.6

*Non-stock standard item with extended delivery time

Adjusting the Chamfer Size

Chamfer size is based on the size of the blade. The maximum possible chamfer size is between 0.5mm and 1.5mm per side depending on the blade size. The maximum chamfer size may not be possible when cutting harder materials such as those with hardness Rc>30 or exotic alloys.

Setting the Blade Force

The blade force can be adjusted with the set screw in the end of the shank. The blade force should be enough to ensure the blade extends completely after passing through the bore. Changing the blade force does not change the chamfer size.

- Increase the blade force by turning the set screw clockwise
- Decrease the blade force by turning the set screw counter-clockwise.

Working with the correct blade pressure increases the blade life and improves the chamfer quality. If a very strong blade force is required, the harder spring can be inserted into the tools of SNAP5 and SNAP12 groups (not standard).

- Harder spring for SNAP5 is GH-H-F-0041
- Harder spring for SNAP12 is GH-H-F-0011
- Add suffix -HS for complete tool (ie. SNAP12-423-HS)

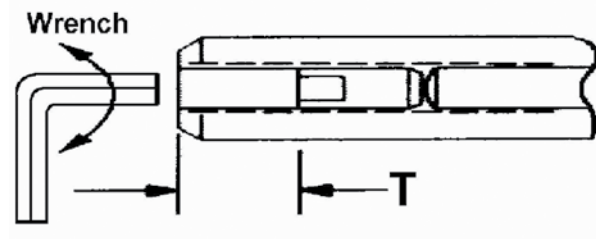

Changing Blades

The blade change in the SNAP tool is quick and easy. There are no tools required and it can be done with the tool in the spindle.

- Remove the blade by simply pushing it past center and out the back of the tool.
- Install the new blade by pushing the back side of the blade through the window until it “snaps”.
- The tool is ready to run.

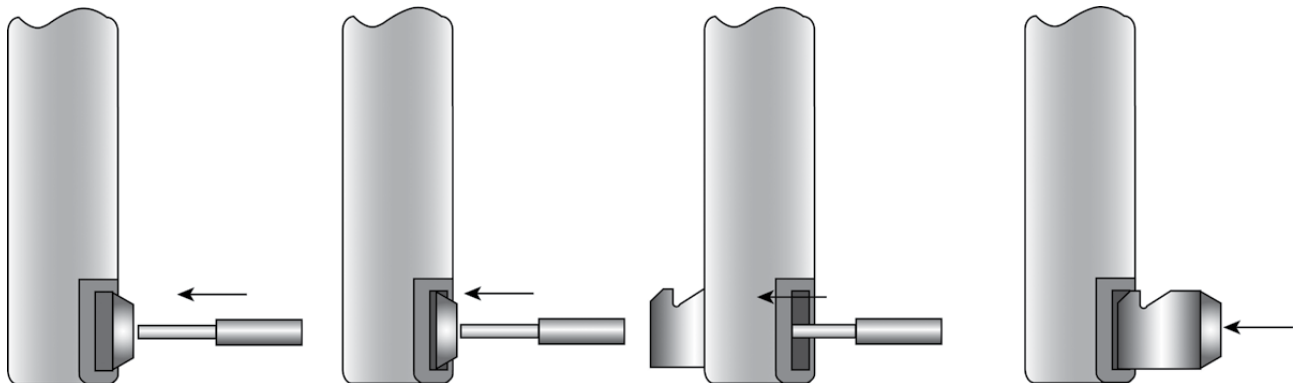

Programming Information

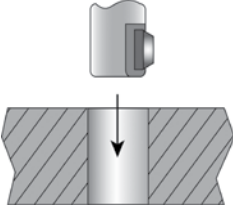
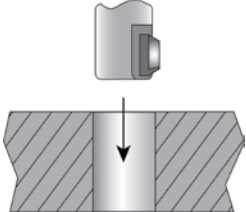
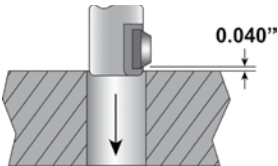
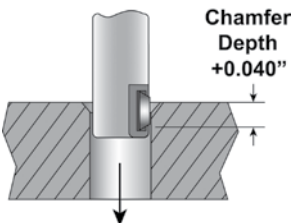
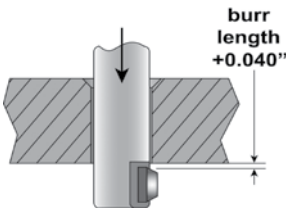
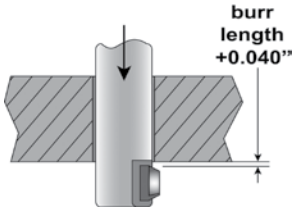
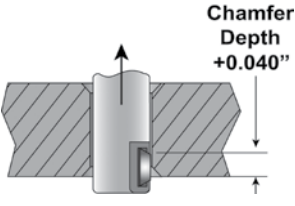
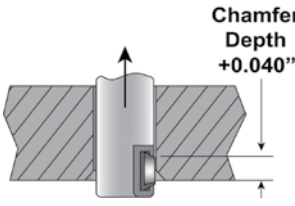
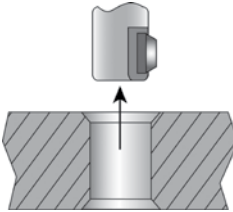
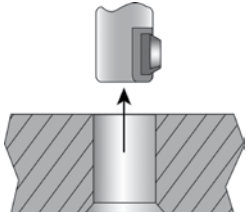
For Front & Back Chamfer		Back Chamfer Only
	<p>Step 1: Set the RPM according to the suggested values.</p>	
	<p>Step 2: (Move into position) Move the tool with rapid feed into position with the front.</p>	
	<p>Step 3: (Cut front chamfer) Machine the part with cutting feed (cf) and speed (cs). Feed into the part the chamfer depth + 0.040" to ensure the tool is finished cutting.</p>	
	<p>Step 4: (Rapid through part) Move the tool through the part with rapid feed until the blade is 0.040" beyond burr. The blade will not damage the through hole.</p>	
	<p>Step 5: (Cut back chamfer) Machine the part with cutting feed (cf) and speed (cs). Feed into the part the chamfer depth + 0.040" to ensure the tool is finished cutting.</p>	
	<p>Step 6: (Remove from the part) Remove the tool from the part with a rapid feed and proceed to the next hole. The blade will not damage the through hole.</p>	

Programming Information (continued)

Material	IPR (SNAP- GS)	IPR (SNAP- DF)	SFM
Aluminum	0.006-0.012	0.001-0.003	400-600
Brass	0.006-0.014	0.001-0.003	210-400
Low Carbon Steels	0.004-0.008	0.001-0.003	200-280
Med Carbon Steels	0.004-0.009	0.001-0.002	175-225
Free Machining Alloys	0.004-0.006	0.001-0.002	200-280
Stainless Steel	0.002-0.005	0.001-0.002	150-225
Gray Cast Iron	0.004-0.008	0.001-0.003	150-250
Nodular Cast Iron	0.003-0.007	0.001-0.002	150-220
Short Chipping Iron	0.003-0.007	0.001-0.002	100-250
Titanium	0.001-0.003	0.001-0.002	40-80

Important Note:
Tool holder must be modified with blade locking mechanism for spindle speeds above 6,000 rpm. Please contact Heule Tool Corporation Engineering Department.

Optional SNAP Locking Mechanism Configuration for Standard SNAP Tool Holders

When Ordering please use a suffix -LM after the standard order number. Locking mechanism allows for higher RPM.

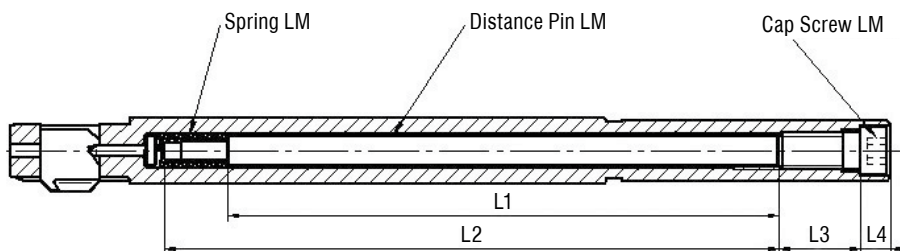

Order Example of SNAP Tooling with Locking Mechanism

SNAP - 8 - 315 - LM

LM Indicates SNAP Tooling with Locking Mechanism

Tooling	Size (mm)	DIMENSIONS (mm)				PART NUMBER		
		L1	L2	L3	L4	Cap Screw - LM	Distance Pin - LM	Spring- LM
SNAP 5	5.0 – 7.5	52.85	61.35	9	3.5	GH-H-S-0538-1	GH-Q-E-0089	GH-H-F-0055
	8 – 9.5	62.85	71.35	9	3.5	GH-H-S-0538-1	GH-Q-E-0090	GH-H-F-0055
	10 – 10.5	71.85	80.35	9	3.5	GH-H-S-0538-1	GH-Q-E-0091	GH-H-F-0055
SNAP8	8 – 12	73.9	82.4	11	4	GH-H-S-0524-5	GH-Q-E-0093	GH-H-F-0012
SNAP12	12 – 20	93.5	102	11	4	GH-H-S-0524-1	GH-Q-E-0094	GH-H-F-0012

Important Note:

Tool holder must be modified for locking mechanism components.

PROBLEM	EXPLANATION	SOLUTION
Chamfer too small	<ul style="list-style-type: none"> Selected blade is too small Blade force is too small Feed rate is too high 	<ul style="list-style-type: none"> Choose larger blade (if possible) Increase blade force Reduce feed rate
No chamfer at all	<ul style="list-style-type: none"> Tool is incorrectly programmed Blade force is too small Blade is dull Too heavy of a burr 	<ul style="list-style-type: none"> Check programming depths Increase blade force Replace the blade Replace the drill tool
Chamfer is too large	<ul style="list-style-type: none"> Selected blade is too large Feed rate too small Blade force too high 	<ul style="list-style-type: none"> Choose a smaller blade Increase the feed rate Reduce the blade force Use DF geometry
Chamfer differs from front to back	<ul style="list-style-type: none"> Feed varies between forward and reverse feed Variation of burr between front and back 	<ul style="list-style-type: none"> Select a constant feed rate Reduce the feed rate when too small or increase feed rate when too large Increase blade tension
Poor surface finish	<ul style="list-style-type: none"> Tool or part not held properly Tool is unstable Speed rate is too high 	<ul style="list-style-type: none"> Ensure tool and part are secured Reduce Speed Check workpiece and holder
Inconsistent chamfer	<ul style="list-style-type: none"> Varying feed rate Incorrect programming position Tool is unstable 	<ul style="list-style-type: none"> Ensure constant feed rate Check workpiece and holder Check programming Reduce Speed
Poor blade life (chipping) (excessive wear)	<ul style="list-style-type: none"> Workpiece or tool not secured Insufficient machine stability Poor cutting conditions 	<ul style="list-style-type: none"> Ensure tool or part is secured Recondition or rectify machine faults Check speed and feed and coolant supply



Grinding may produce hazardous dust. To avoid adverse effects, use adequate ventilation and read MSDS. Cutting tools may break during use. To avoid injury, use proper safety precautions and protective equipment. Use the machine tool with sufficient rigidity and horsepower. Use a cover on a machine tool and protector, such as glasses, against shattering chips and broken tools due to misuse. Do not use insoluble oil because there is a danger of causing fire.

VEX-S

Combination Drill with Front & Back Chamfering of Through Holes

- High performance solid carbide drill tip combined with patented SNAP chamfering system
- VEX drill geometry for better chip control
- Quick and easy drill tip and chamfer blade replacement
- No presetting between drill changes

The VEX-S Tool combines a new high performance solid carbide drill with Heule's patented SNAP chamfering system to drill and chamfer through holes in a single operation. Combining common operations increases the user's productivity and efficiency while maintaining quality. The specially developed connecting system ensures a robust and accurate connection with the tool body and facilitates good transmission of power and also allows quick and easy replacement of the VEX-S twist drill. The replaceable VEX drill tip can be reground and recoated for optimum cost effectiveness and is available in sizes 5-12.0 mm.

New VEX Drill Geometry

With the new patented VEX self centering cutting geometry, HEULE is setting new benchmarks in the field of drilling technology. The new VEX cutting geometry guarantees high drilling performance with short chips. Due to the convex cutting edge (1) which merges into a concave chip angle (2) short chips are guaranteed even when machining a long chipping material. A large chip channel also optimizes swarf evacuation.

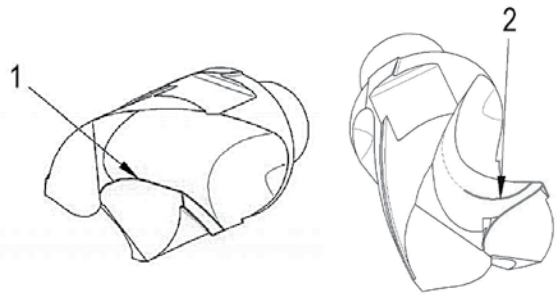

Typical Applications

The VEX-S tool is ideal for drilling smaller diameters and is well suited for the automotive industry and other high production environments. Applications include brake discs, various tube applications, wheel hubs and other components.



Standard and Special Tooling

The VEX-S tool is available from stock in sizes 5-12 mm in the 1xd tooling; other options are available upon request. VEX-S is also available for special design and build custom tooling to suit many special application needs. Contact Heule Tool Corporation for further information if you need a customized tool.

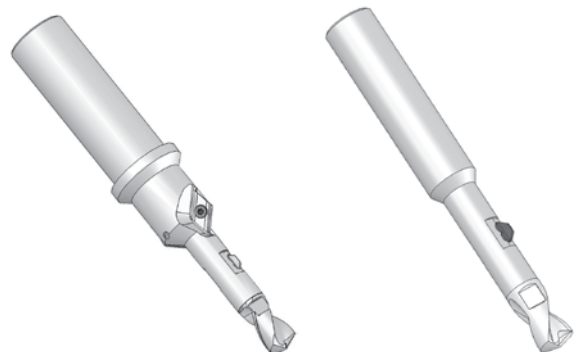

How to Select a VEX-S Tool

1. Determine the drill hole size.
2. Select the appropriate Drill Tip and the coordinating Tool holder.
3. Choose the SNAP chamfer blade according to the needed chamfer size.

Sample Order: Ø3/8" Drill Hole: 1pc P-S-E2-0953-1A VEX-S DRILL Ø3/8", TiAlN, Series E, 1:1
 1pc VEXS-9.5-1d VEX-S Tool Holder Ø9.5 Series E, 1:1, without inserts
 1pc GH-Q-M-30214 SNAP5 Chamfer Blade Ø10.5mm, Carb- TiAlN

1 Series

Bore Range	Series
5.00-5.99	B
6.00-6.99	C
7.00-8.49	D
8.50-10.49	E
10.50-11.49	F

2 Bore-depth T

.5xd	1
1xd	2
1.5xd	3
2xd	4

3 Bore Diameter Ød

Indicate the bore diameter here. For example: Ø9.50 = 0950
 Standard size as shown.

4 Cutting Material

Carbide K20-K30	1
-----------------	---

5 Coating

Uncoated	U
TiN	T
TiAlN	A
DLC	D
Helica*	H*

*Will soon be discontinued - replaced with TiAlN

Drill Blade Dimensions

Bore Range	Series	X1	Bore Depth			Bore Depth			Wrench Size	Torque Setting	Flat Wrench
			T	L	L1	T	L	L1			
Ød3		X1	T	L	L1	T	L	L1	SW	Ncm	GH-H-S-
5.0-5.49	B	1.00	5.0	10.2	14.7				4	170	2301
5.5-5.99		1.10	5.5	11.1	15.6				4	170	2301
6.0-6.49	C	1.20	6.0	11.7	16.2	12	18.4	22.9	5	250	2301
6.5-6.99		1.30	6.5	12.7	17.2	13	20.0	24.5	5	250	2301
7.0-7.49	D	1.35	7.0	13.6	19.1	14	21.4	26.9	6	400	2302
7.5-7.99		1.45	7.5	14.4	19.9	15	22.7	28.2	6	400	2302
8.0-8.49	E	1.55	8.0	15.2	20.7	16	24.0	29.5	7	400	2302
8.5-8.99		1.65	8.5	16.1	21.6	17	25.4	30.9	7	600	2302
9.0-9.49	E	1.75	9.0	16.9	22.4	18	26.7	32.2	8	600	2303
9.5-9.99		1.85	9.5	17.8	23.3	19	28.1	33.6	8	600	2303
10.0-10.49	F	1.90	10.0	18.6	24.1	20	29.4	34.9	9	600	2303
10.5-10.99		2.10	10.5	19.1	24.6	21	30.2	35.7	9	600	2303
11.0-11.49	F	2.22	11.0	19.9	25.4	22	31.5	37.0	9	600	2303

Order Number Example: P-S-E 2-0950-1 A

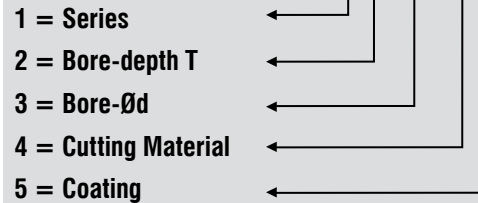

Order Example:

Bore-Ød	= 9.50mm
Carbide Quality	= K20-K30
Coating	= TiAlN = 9.50mm
Bore-depth T	1xd
Order Number: P-S-E2-0950-1A	

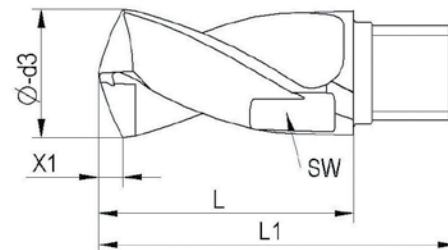

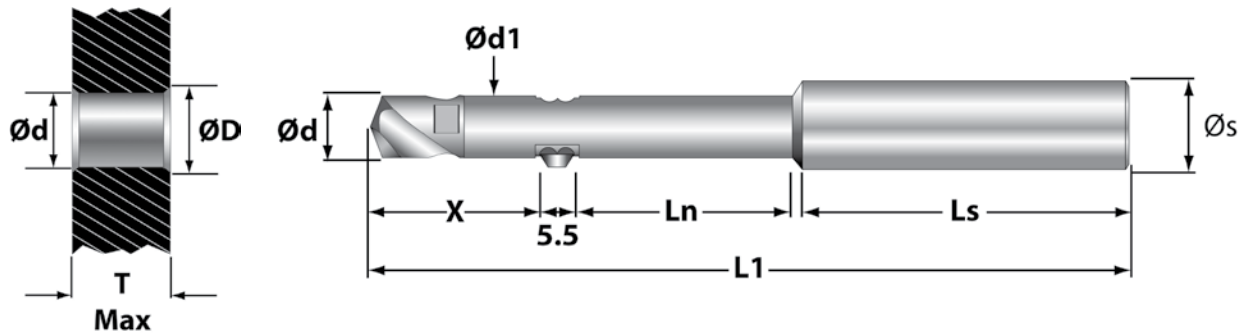

VEX-S Series B, C and D - 1xd Tools

Tool Holder Order Number	Ød Range mm	T Max	Ød1	X	L1	Ln	Ls	Øs
GH-Q-O-4000	5.0 - 5.4	5.0 (.197")	4.9 (.193")	18.9 (.744")	70.5 (2.776")	7.5 (.295")	36.0 (1.417")	8.0 (.315")
GH-Q-O-4001	5.5 - 5.9	5.5 (.217")	5.4 (.213")	19.8 (.780")	71.6 (2.776")	8.0 (.315")	36.0 (1.417")	8.0 (.315")
GH-Q-O-4052	6.0 - 6.4	6.0 (.236")	5.9 (.232")	20.6 (.811")	84.1 (3.311")	15.0 (.591")	40.0 (1.575")	10.0 (.394")
GH-Q-O-4053	6.5 - 6.9	6.5 (.256")	6.4 (.252")	21.6 (.850")	86.1 (3.390")	16.0 (.630")	40.0 (1.575")	10.0 (.394")
GH-Q-O-4054	7.0 - 7.4	7.0 (.276")	6.9 (.272")	23.8 (.937")	89.3 (3.518")	17.0 (.669")	40.0 (1.575")	10.0 (.394")
GH-Q-O-4055	7.5 - 7.9	7.5 (.295")	7.4 (.291")	24.6 (.969")	91.1 (3.587")	18.0 (.709")	40.0 (1.575")	10.0 (.394")
GH-Q-O-4056	8.0 - 8.4	8.0 (.315")	7.9 (.311")	25.4 (1.000")	92.9 (3.658")	19.0 (.748")	45.0 (1.772")	12.0 (.472")

VEX-S Series B, C and D - 1xd Drills and Blades

Series	Ød Drill* mm inches	Tool Holder Order Number	Drill Tip Order #	Chmf. Series	Chamfer Blade Order Number (fab)**			
					(0.25mm x 45°) GH-Q-M-	(0.5mm x 45°) GH-Q-M-	(0.75mm x 45°) GH-Q-M-	(1.0mm x 45°) GH-Q-M-
B	5.0mm (.197)	GH-Q-O-4000	P-S-B2-0500-1A	5	-30204 (5.5)	-30205 (6.0)	-30206 (6.5)	-30207 (7.0)
	5.1mm (.201)	GH-Q-O-4000	P-S-B2-0510-1A		-30204 (5.5)	-30205 (6.0)	-30206 (6.5)	-30207 (7.0)
	5.5mm (.217)	GH-Q-O-4001	P-S-B2-0550-1A		-30205 (6.0)	-30206 (6.5)	-30207 (7.0)	-30208 (7.5)
C	6.0mm (.236)	GH-Q-O-4052	P-S-C2-0600-1A		-30206 (6.5)	-30207 (7.0)	-30208 (7.0)	-30209 (7.0)
	6.35mm (1/4")	GH-Q-O-4052	P-S-C2-0635-1A		-30206 (6.5)	-30207 (7.0)	-30208 (7.5)	-30209 (8.0)
	6.5mm (.256)	GH-Q-O-4053	P-S-C2-0650-1A		-30207 (7.0)	-30208 (7.5)	-30209 (8.0)	-30210 (8.5)
	6.8mm (.268)	GH-Q-O-4053	P-S-C2-0680-1A		-30207 (7.0)	-30208 (7.5)	-30209 (8.0)	-30210 (8.5)
D	7.0mm (.276)	GH-Q-O-4054	P-S-D2-0700-1A		-30208 (7.5)	-30209 (8.0)	-30210 (8.5)	-30211 (9.0)
	7.14mm (9/32")	GH-Q-O-4054	P-S-D2-0714-1A		-30208 (7.5)	-30209 (8.0)	-30210 (8.5)	-30211 (9.0)
	7.5mm (.295)	GH-Q-O-4055	P-S-D2-0750-1A		-30209 (8.0)	-30210 (8.5)	-30211 (9.0)	-30212 (9.5)
	7.94mm (5/16")	GH-Q-O-4055	P-S-D2-0794-1A		-30210 (8.5)	-30211 (9.0)	-30212 (9.5)	-30213 (10.0)
	8.0mm (.315)	GH-Q-O-4056	P-S-D2-0800-1A		-30210 (8.5)	-30211 (9.0)	-30212 (9.5)	-30213 (10.0)
	8.4mm (.331)	GH-Q-O-4056	P-S-D2-0840-1A	-30211 (9.0)	-30212 (9.5)	-30213 (10.0)	-30214 (10.5)	

*Other drill sizes available on request. Example: Ød = 8.33mm (.328") - P-S-D4-0833-1A

** Chamfer blades are interchangeable; maximum chamfer diameter ØD = hole Ød + 2mm

BLADE
OPTIONS PG. 73

SPARE
PARTS PG. 100

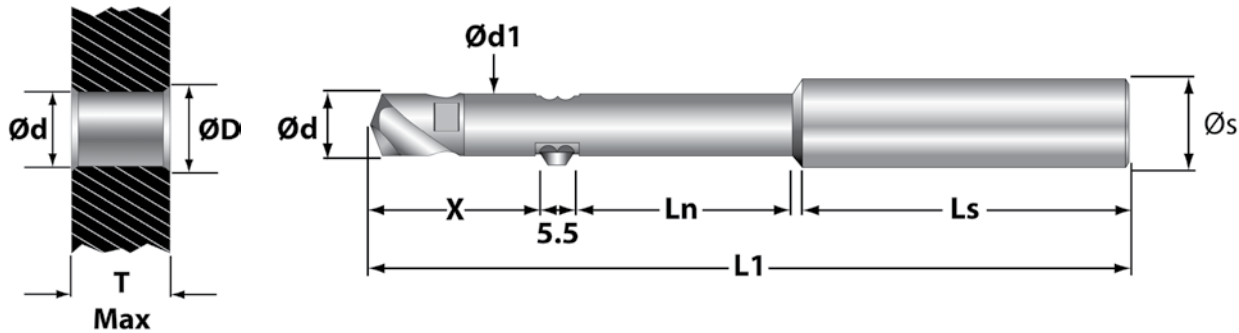

VEX-S Series E and F - 1xd Tools

Tool Holder Order Number	Ød Range mm	T Max	Ød1	X	L1	Ln	Ls	Øs
GH-Q-O-4057	8.5 - 8.9	8.5 (.335")	8.4 (.331")	26.6 (1.047")	100.1 (3.941")	20.0 (.787")	45.0 (1.772)	12.0 (.472")
GH-Q-O-4058	9.0 - 9.4	9.0 (.354")	8.9 (.350")	27.4 (1.079")	101.9 (4.012")	21.0 (.827")	45.0 (1.772)	12.0 (.472")
GH-Q-O-4059	9.5 - 9.9	9.5 (.374")	9.4 (.370")	28.3 (1.114")	103.8 (4.087")	22.0 (.866")	45.0 (1.772)	12.0 (.472")
GH-Q-O-4060	10.0 - 10.4	10.0 (.394")	9.9 (.390")	29.5 (1.161")	106.0 (4.173")	23.0 (.906")	45.0 (1.772)	14.0 (.551")
GH-Q-O-4061	10.5 - 11.0	10.5 (.413")	10.4 (.409")	30.1 (1.185")	107.4 (4.228")	24.0 (.945")	45.0 (1.772)	14.0 (.551")
GH-Q-O-4062	11.0 - 11.4	11.0 (.433")	10.9 (.429")	30.9 (1.217")	108.9 (4.287")	24.0 (.945")	45.0 (1.772)	14.0 (.551")

VEX-S Series E and F - 1xd Drills and Blades

Series	Ød Drill* mm inches	Tool Holder Order Number	Drill Tip Order #	Cmt. Series	Chamfer Blade Order Number (fab)**			
					(0.25mm x 45°) GH-Q-M-	(0.5mm x 45°) GH-Q-M-	(0.75mm x 45°) GH-Q-M-	(1.0mm x 45°) GH-Q-M-
E	8.5mm (.335)	GH-Q-O-4057	P-S-E2-0850-1A	5	-30211 (9.0)	-30212 (9.5)	-30213 (10.0)	-30214 (10.5)
	8.73mm (11/32")	GH-Q-O-4057	P-S-E2-0873-1A		-30212 (9.5)	-30213 (10.0)	-30214 (10.5)	-30215 (11.0)
	9.0mm (.354)	GH-Q-O-4058	P-S-E2-0900-1A		-30212 (9.5)	-30213 (10.0)	-30214 (10.5)	-30215 (11.0)
	9.35mm (.368)	GH-Q-O-4058	P-S-E2-0935-1A		-30213 (10.0)	-30214 (10.5)	-30215 (11.0)	-30216 (11.5)
	9.5mm (.374)	GH-Q-O-4059	P-S-E2-0950-1A		-30213 (10.0)	-30214 (10.5)	-30215 (11.0)	-30216 (11.5)
	9.53mm (3/8")	GH-Q-O-4059	P-S-E2-0953-1A		-30213 (10.0)	-30214 (10.5)	-30215 (11.0)	-30216 (11.5)
	10.0mm (.394)	GH-Q-O-4060	P-S-E2-1000-1A		-30214 (10.5)	-30215 (11.0)	-30216 (11.5)	-30217 (12.0)
	10.3mm (.406)	GH-Q-O-4060	P-S-E2-1030-1A		-30215 (11.0)	-30216 (11.5)	-30217 (12.0)	-30218 (12.5)
F	10.5mm (.413)	GH-Q-O-4061	P-S-F2-1050-1A	-30215 (11.0)	-30216 (11.5)	-30217 (12.0)	-30218 (12.5)	
	11.0mm (.433)	GH-Q-O-4062	P-S-F2-1100-1A	-30216 (11.5)	-30217 (12.0)	-30218 (12.5)	-30219 (13.0)	
	11.1mm (.437)	GH-Q-O-4062	P-S-F2-1110-1A	-30216 (11.5)	-30217 (12.0)	-30218 (12.5)	-30219 (13.0)	

*Other drill sizes available on request. Example: Ød = 8.33mm (.328") - P-S-D4-0833-1A

** Chamfer blades are interchangeable; maximum chamfer diameter ØD = hole Ød + 2mm

BLADE OPTIONS PG. 73

PROGRAMMING PG. 98-99

HTC015

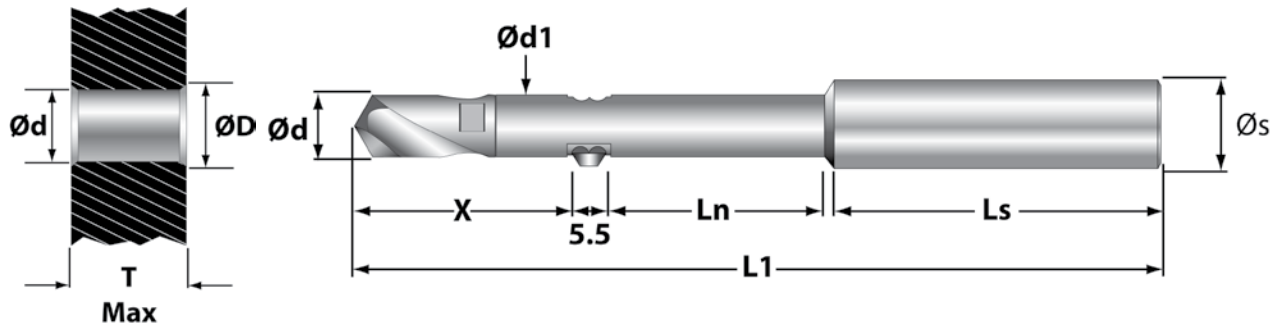

VEX-S Series C and D - 2xd Tools

Tool Holder Order Number	Ød Range mm	T Max	Ød1	X	L1	Ln	Ls	Øs
GH-Q-O-4052	6.0 - 6.4	12.0 (.472")	5.9 (.232")	27.3 (1.075")	90.8 (3.575")	15.0 (.591")	40.0 (1.575")	10.0 (.394")
GH-Q-O-4053	6.5 - 6.9	13.0 (.512")	6.4 (.252")	28.9 (1.138")	93.3 (3.673")	16.0 (.630")	40.0 (1.575")	10.0 (.394")
GH-Q-O-4054	7.0 - 7.4	14.0 (.551")	6.9 (.272")	31.6 (1.244")	96.7 (3.807")	17.0 (.669")	40.0 (1.575")	10.0 (.394")
GH-Q-O-4055	7.5 - 7.9	15.0 (.591")	7.4 (.291")	32.9 (1.295")	98.7 (3.886")	18.0 (.709")	40.0 (1.575")	10.0 (.394")
GH-Q-O-4056	8.0 - 8.4	16.0 (.630")	7.9 (.311")	33.3 (1.465")	106.8 (4.205")	19.0 (.748")	40.0 (1.575")	12.0 (.394")

VEX-S Series C and D - 2xd Drills and Blades

Series	Ød Drill* mm inches	Tool Holder Order Number	Drill Tip Order #	Cmt. Series	Chamfer Blade Order Number (fab)**			
					(0.25mm x 45°) GH-Q-M-	(0.5mm x 45°) GH-Q-M-	(0.75mm x 45°) GH-Q-M-	(1.0mm x 45°) GH-Q-M-
C	6.0mm (.236)	GH-Q-O-4052	P-S-C4-0600-1A	5	-30206 (6.5)	-30207 (7.0)	-30207 (7.0)	-30207 (7.0)
	6.35mm (1/4")	GH-Q-O-4052	P-S-C4-0635-1A		-30206 (6.5)	-30207 (7.0)	-30208 (7.5)	-30209 (8.0)
	6.5mm (.256)	GH-Q-O-4053	P-S-C4-0650-1A		-30207 (7.0)	-30208 (7.5)	-30209 (8.0)	-30210 (8.5)
	6.8mm (.268)	GH-Q-O-4053	P-S-C4-0680-1A		-30207 (7.0)	-30208 (7.5)	-30209 (8.0)	-30210 (8.5)
D	7.0mm (.276)	GH-Q-O-4054	P-S-D4-0700-1A		-30208 (7.5)	-30209 (8.0)	-30210 (8.5)	-30211 (9.0)
	7.14mm (9/32")	GH-Q-O-4054	P-S-D4-0714-1A		-30208 (7.5)	-30209 (8.0)	-30210 (8.5)	-30211 (9.0)
	7.5mm (.295)	GH-Q-O-4055	P-S-D4-0750-1A		-30209 (8.0)	-30210 (8.5)	-30211 (9.0)	-30212 (9.5)
	7.94mm (5/16")	GH-Q-O-4055	P-S-D4-0794-1A		-30210 (8.5)	-30211 (9.0)	-30212 (9.5)	-30213 (10.0)
	8.0mm (.315)	GH-Q-O-4056	P-S-D4-0800-1A		-30210 (8.5)	-30211 (9.0)	-30212 (9.5)	-30213 (10.0)
	8.4mm (.331)	GH-Q-O-4056	P-S-D4-0840-1A		-30211 (9.0)	-30212 (9.5)	-30213 (10.0)	-30214 (10.5)

*Other drill sizes available on request. Example: Ød = 8.33mm (.328") - P-S-D2-0833-1A

** Chamfer blades are interchangeable; maximum chamfer diameter ØD = hole Ød + 2mm

BLADE
OPTIONS **PG. 75**

SPARE
PARTS **PG. 100**

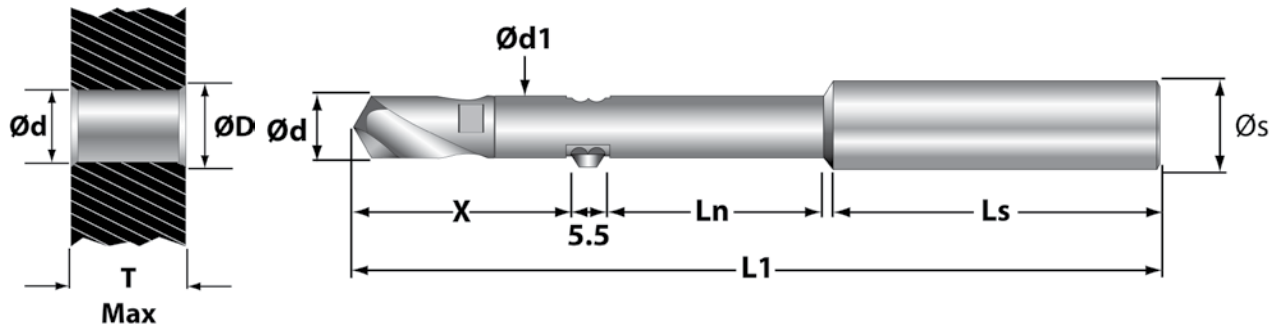

VEX-S Series E and F - 2xd Tools

Tool Holder Order Number	Ød Range mm	T Max	Ød1	X	L1	Ln	Ls	Øs
GH-Q-O-4057	8.5 - 8.9	17.0 (.669")	8.4 (.331")	35.8 (1.409")	109.1 (4.295")	20.0 (.787")	40.0 (1.575")	12.0 (.472")
GH-Q-O-4058	9.0 - 9.4	18.0 (.709")	8.9 (.350")	37.2 (1.465")	111.2 (4.378")	21.0 (.827")	45.0 (1.772")	12.0 (.472")
GH-Q-O-4059	9.5 - 9.9	19.0 (.748")	9.4 (.370")	38.6 (1.520")	113.3 (4.461")	22.0 (.866")	45.0 (1.772")	12.0 (.472")
GH-Q-O-4060	10.0 - 10.4	20.0 (.787")	9.9 (.390")	39.9 (1.571")	116.4 (4.583")	23.0 (.906")	45.0 (1.772")	14.0 (.551")
GH-Q-O-4061	10.5 - 10.9	21.0 (.827")	10.4 (.409")	41.2 (1.622")	118.5 (4.665")	24.0 (.945")	45.0 (1.772")	14.0 (.551")
GH-Q-O-4062	11.0 - 11.4	22.0 (.866")	10.9 (.429")	42.5 (1.673")	120.5 (4.744")	25.0 (.984")	45.0 (1.772")	14.0 (.551")

VEX-S Series E and F - 2xd Drills and Blades

Series	Ød Drill* mm inches	Tool Holder Order Number	Drill Tip Order #	Cmf. Series	Chamfer Blade Order Number (fab)**			
					(0.25mm x 45°) GH-Q-M-	(0.5mm x 45°) GH-Q-M-	(0.75mm x 45°) GH-Q-M-	(1.0mm x 45°) GH-Q-M-
E	8.5mm (.335)	GH-Q-O-4057	P-S-E4-0850-1A	5	-30211 (9.0)	-30212 (9.5)	-30213 (10.0)	-30214 (10.5)
	8.73mm (11/32")	GH-Q-O-4057	P-S-E4-0873-1A		-30212 (9.5)	-30213 (10.0)	-30214 (10.5)	-30215 (11.0)
	9.0mm (.354)	GH-Q-O-4058	P-S-E4-0900-1A		-30212 (9.5)	-30213 (10.0)	-30214 (10.5)	-30215 (11.0)
	9.35mm (.368)	GH-Q-O-4058	P-S-E4-0935-1A		-30213 (10.0)	-30214 (10.5)	-30215 (11.0)	-30216 (11.5)
	9.5mm (.374)	GH-Q-O-4059	P-S-E4-0950-1A		-30213 (10.0)	-30214 (10.5)	-30215 (11.0)	-30216 (11.5)
	9.53mm (3/8")	GH-Q-O-4059	P-S-E4-0953-1A		-30213 (10.0)	-30214 (10.5)	-30215 (11.0)	-30216 (11.5)
	10.0mm (.394)	GH-Q-O-4060	P-S-E4-1000-1A		-30214 (10.5)	-30215 (11.0)	-30216 (11.5)	-30217 (12.0)
	10.3mm (.406)	GH-Q-O-4060	P-S-E4-1030-1A		-30215 (11.0)	-30216 (11.5)	-30217 (12.0)	-30218 (12.5)
F	10.5mm (.413)	GH-Q-O-4061	P-S-F4-1050-1A	-30215 (11.0)	-30216 (11.5)	-30217 (12.0)	-30218 (12.5)	
	11.0mm (.433)	GH-Q-O-4062	P-S-F4-1100-1A	-30216 (11.5)	-30217 (12.0)	-30218 (12.5)	-30219 (13.0)	
	11.1mm (.437)	GH-Q-O-4062	P-S-F4-1110-1A	-30216 (11.5)	-30217 (12.0)	-30218 (12.5)	-30219 (13.0)	

*Other drill sizes available on request. Example: Ød = 8.33mm (.328") - P-S-D2-0833-1A

** Chamfer blades are interchangeable; maximum chamfer diameter ØD = hole Ød + 2mm

BLADE
OPTIONS **PG. 77**

PROGRAMMING **PG. 98-99**

VEX-S Speeds and Feeds

IMPORTANT: Tool holder must be modified with blade locking mechanism for spindle speeds above 6,000 rpm. Please contact Heule Tool Corporation Engineering Department.

Material	SFM	IPR		
		Ø5-6.5	Ø6.5-8	Ø8-11.5
Unalloyed steel	300-400	.003-.005	.004-.008	.006-.010
Cast steel	150-250	.003-.005	.004-.008	.006-.010
Low-alloy steel	250-400	.003-.005	.004-.008	.006-.010
Free machining steel	220-350	.003-.005	.004-.008	.006-.010
High-alloy steel	130-220	.002-.004	.003-.006	.004-.008
Stainless steel	100-160	.001-.002	.002-.003	.003-.004
Grey cast iron	275-500	.004-.007	.006-.010	.008-.013
Nodular cast iron	275-450	.003-.006	.004-.009	.006-.012
Aluminium-forging alloys	380-600	.005-.007	.007-.010	.010-.013
Aluminium-casting alloys	300-600	.005-.007	.007-.010	.010-.013
Brass	300-500	.005-.007	.007-.010	.010-.013
Bronze-short chipping	200-300	.004-.006	.006-.009	.008-.012
Bronze-long chipping	130-200	.003-.005	.004-.008	.006-.010

VEX-S Programming Sequence



It is not necessary to change the direction of rotation or stop the spindle

AV: Working feed, forward

AR: Working feed, backward

EV: Rapid feed, forward

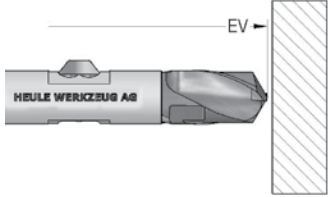
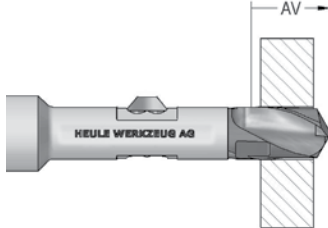
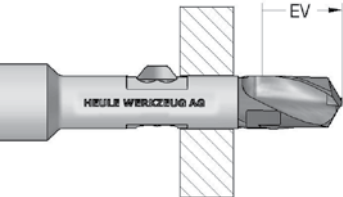
ER: Rapid feed, backward

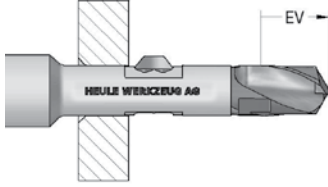
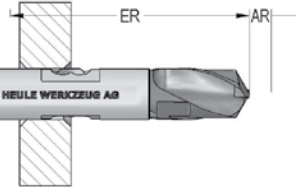
	<p>Step 1: Rapid Feed the tool to within clearance of the workpiece.</p>
	<p>Step 2: With forward Working Feed (WF), feed the tool through the workpiece until the hole is drilled and the drill tip is clear of the bore.</p>
	<p>Step 3: Rapid feed the tool so the SNAP blade is within clearance of the workpiece top surface or burr.</p>
	<p>Step 4: With working feed, cut the top chamfer. Continue feeding until the SNAP blade is completely retracted into the tool body.</p>
	<p>Step 5: Use rapid feed to position the SNAP blade on the far side of the part. Position the tool so the SNAP blade is completely extended and clear of the part or burr.</p>
	<p>Step 6: With back working feed, cut the back chamfer. When the SNAP blade is completely within the tool and clear of the back surface, the tool can be extracted with rapid feed.</p>

HTC015

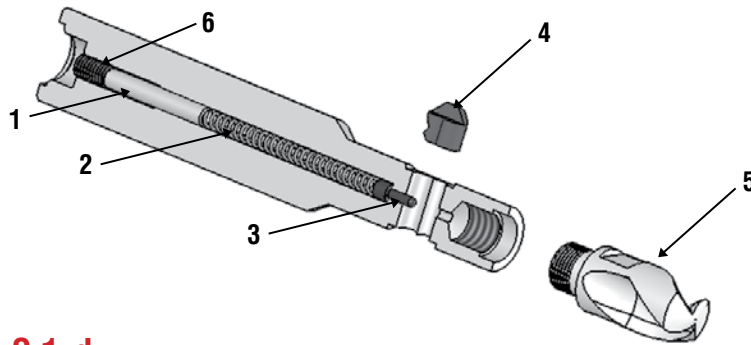

Spare Parts – VEX-S 1xd

Tool Holder	1	2	3	4	5	6
GH-Q-0-	Distance Pin	Spring	Control Bolt	Blade	Drill Tip	Screw Set
4000 4001	GH-Q-E-0052	GH-H-F-0019	GH-Q-E-0008	See Below	See Pages 94-95	GH-H-S-0127

Spare Parts – VEX-S 2xd

Tool Holder	1	2	3	4	5	6
GH-Q-0-	Distance Pin	Spring	Control Bolt	Blade	Drill Tip	Screw Set
4052 4053 4054 4055	GH-Q-E-0048	GH-H-F-0019	GH-Q-E-0008	See Below	See Pages 96-97	GH-H-S-0127
4056 4057 4058 4059 4060 4061 4062	GH-Q-E-0039	GH-H-F-0019	GH-Q-E-0008	See Below	See Pages 96-97	GH-H-S-0127

Bore Range	Tool Holder	SNAP 5 Blade, Carbide TiAlN 90°, front and back cutting Order Number and (Chamfer ØD mm)			
5.0-5.49	GH-Q-0-4000	GH-Q-M-30205 (6.0)	GH-Q-M-30206 (6.5)	GH-Q-M-30207 (7.0)	
5.5-5.99	GH-Q-0-4001	GH-Q-M-30206 (6.5)	GH-Q-M-30207 (7.0)	GH-Q-M-30208 (7.5)	
6.0-6.49	GH-Q-0-4052	GH-Q-M-30207 (7.0)	GH-Q-M-30208 (7.5)	GH-Q-M-30209 (8.0)	
6.5-6.99	GH-Q-0-4053	GH-Q-M-30208 (7.5)	GH-Q-M-30209 (8.0)	GH-Q-M-30210 (8.5)	
7.0-7.49	GH-Q-0-4054	GH-Q-M-30209 (8.0)	GH-Q-M-30210 (8.5)	GH-Q-M-30211 (9.0)	
7.5-7.99	GH-Q-0-4055	GH-Q-M-30210 (8.5)	GH-Q-M-30211 (9.0)	GH-Q-M-30212 (9.5)	
8.0-8.49	GH-Q-0-4056	GH-Q-M-30211 (9.0)	GH-Q-M-30212 (9.5)	GH-Q-M-30213 (10.0)	
8.5-8.99	GH-Q-0-4057	GH-Q-M-30212 (9.5)	GH-Q-M-30213 (10.0)	GH-Q-M-30214 (10.5)	
9.0-9.49	GH-Q-0-4058	GH-Q-M-30213 (10.0)	GH-Q-M-30214 (10.5)	GH-Q-M-30215 (11.0)	
9.5-9.99	GH-Q-0-4059	GH-Q-M-30214 (10.5)	GH-Q-M-30215 (11.0)	GH-Q-M-30216 (11.5)	
10.0-10.49	GH-Q-0-4060	GH-Q-M-30215 (11.0)	GH-Q-M-30216 (11.5)	GH-Q-M-30217 (12.0)	
10.5-10.99	GH-Q-0-4061	GH-Q-M-30216 (11.5)	GH-Q-M-30217 (12.0)	GH-Q-M-30218 (12.5)	
10.0-11.49	GH-Q-0-4062	GH-Q-M-30217 (12.0)	GH-Q-M-30218 (12.5)	GH-Q-M-30219 (13.0)	

Note: For blade dimensions, see page 73. For wrench and drill tip dimensions, see page 93.

How to Change the VEX Drill Tip

Assembly:

Step 1:

Clean the surfaces between the VEX-S twist drill and the tool body.

Step 2:

Screw the VEX-S drill insert tightly with a flat wrench to the tool body.

Step 3:

Check to make sure there is a seamless connection between the drill insert and tool body after tightening the drill insert. There should not be any gaps.

NOTE: There are a few situations that could cause gaps;

- Dirt between drill and tool body.
To fix: remove the VEX-S twist drill and clean.
- VEX-S twist drill is not tight enough.
To fix: tighten the VEX-S twist drill.
- Adaption areas are damaged.
To fix: exchange the VEX-S twist drill and/or VEX-S tool body.

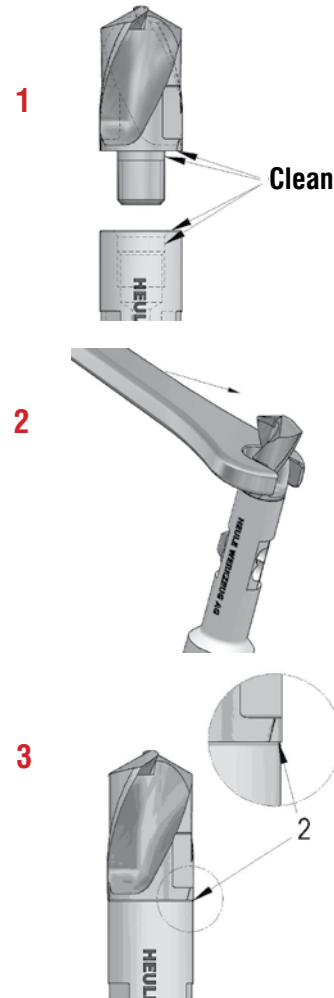

Disassembly:

Step 1:

Unscrew the VEX-S twist drill with a flat wrench in counter-clockwise direction from the tool body and remove the twist drill.

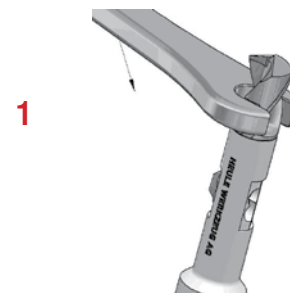

Wrenches:

Be sure to use the wrenches available from HEULE to assemble the VEX-S tools. This chart explains which wrench goes with which series.

Wrenches	Description	Distance Across Flats
GH-H-S-2301	Wrench; Series B&C, 5.0-6.99	4 or 5mm
GH-H-S-2302	Wrench; Series D&E 7.0-8.99	6 or 7mm
GH-H-S-2303	Wrench; Series E&F, 9.0-11.5	8 or 9mm

Problem	Explanation	Solution
Built-up material on cutting edge	<ul style="list-style-type: none"> • Cutting Speed is too slow • Feed Rate is too slow • Coating is incorrect for this material • Insufficient coolant flow 	<ul style="list-style-type: none"> • Increase cutting Speed • Increase Feed Rate • Change Drill Tip Coating • Adjust coolant flow or position
Chips Jamming in the Chip Gullet	<ul style="list-style-type: none"> • Feed rate is too high for chip evacuation • Drill tip is too short for material thickness • Insufficient coolant flow 	<ul style="list-style-type: none"> • Reduce feed rate • Use a Peck Drill cycle • Adjust coolant flow or position • Use longer drill
Burr Formation on the Exit of the Bore (see SNAP troubleshooting on page 56 for burr removal issues)	<ul style="list-style-type: none"> • Feed and Speed Rate is too high • Drill Tip worn • Insufficient coolant flow 	<ul style="list-style-type: none"> • Reduce cutting speed • Reduce exit feed 50% • Exchange worn drill tip • Adjust coolant flow or position
Hole size is inconsistent or not symmetrical	<ul style="list-style-type: none"> • Feed is too heavy • Spindle, fixture or set-up is not stable • Insufficient coolant flow 	<ul style="list-style-type: none"> • Reduce feed rate • Check stability of set up • Check rotation • Adjust coolant flow or position
Poor Surface finish Quality	<ul style="list-style-type: none"> • Drill Tip worn • Incorrect feeds and speeds • Spindle, fixture or set-up is not stable • Insufficient coolant flow 	<ul style="list-style-type: none"> • Exchange worn drill tip • Change feed and speed • Check stability of set up • Adjust coolant flow or position
Chatter during drilling (this must be corrected to avoid tool breakage)	<ul style="list-style-type: none"> • Incorrect feeds and speeds (normally insignificant feed rate) • Spindle, fixture or set-up is not stable • Insufficient coolant flow 	<ul style="list-style-type: none"> • Reduce cutting speed • Increase feed rate • Check stability of set up • Adjust coolant flow or position
Excessive Cutting Edge Wear	<ul style="list-style-type: none"> • Incorrect feeds and speeds (normally lacking cutting speed) • Spindle, fixture or set-up is not stable • Insufficient coolant flow 	<ul style="list-style-type: none"> • Increase cutting speed • Decrease feed rate • Check stability of set up • Adjust coolant flow or position
Chipping of Cutting Edge	<ul style="list-style-type: none"> • Material building up on Cutting edge (chipping off) • Incorrect feeds and speeds (normally lacking cutting speed) • Spindle, fixture or set-up is not stable • Entering / Exiting on incline, or irregular surface • Insufficient coolant flow 	<ul style="list-style-type: none"> • Increase cutting speed • Reduce feed rate. • Enter / Exit irregularities at 50% of feed rate • Check stability of set up • Adjust coolant flow or position
Excessive Margin Wear (Corner wear or discoloration on Margins O.D.)	<ul style="list-style-type: none"> • Incorrect feeds and speeds (normally excessive cutting speed) • Tool is running out of round • Insufficient coolant flow 	<ul style="list-style-type: none"> • Reduce cutting speed • Check run out • Check stability of set up • Adjust coolant flow or position
Chipping of the Top of the Drill-bit	<ul style="list-style-type: none"> • Drill is deflecting during drilling 	<ul style="list-style-type: none"> • Reduce feed rate • Check stability of set up

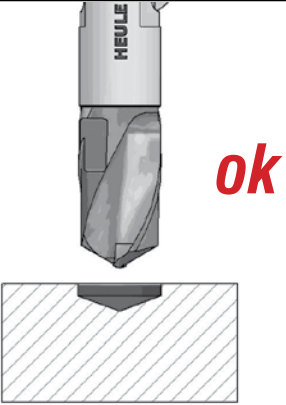
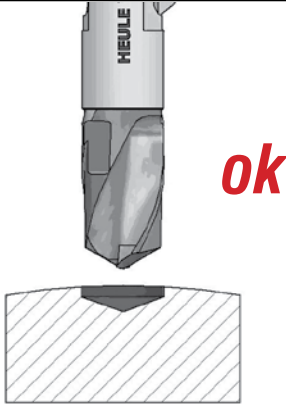
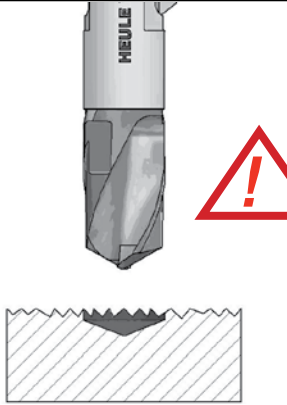
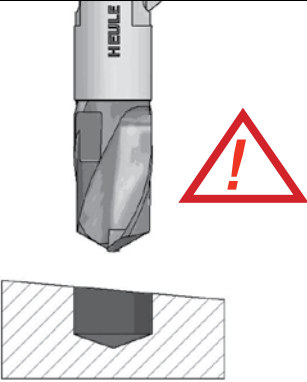
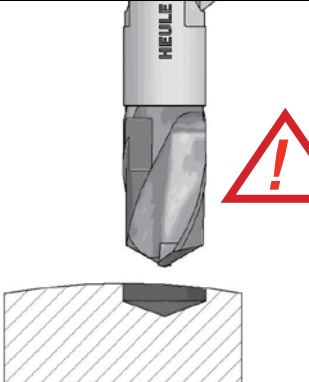
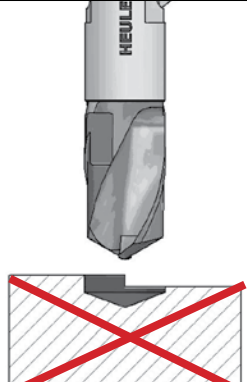
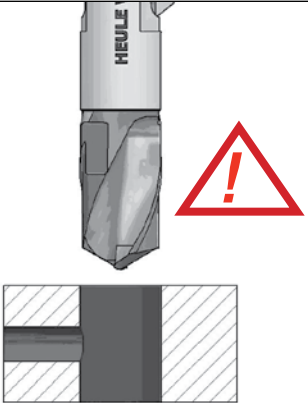
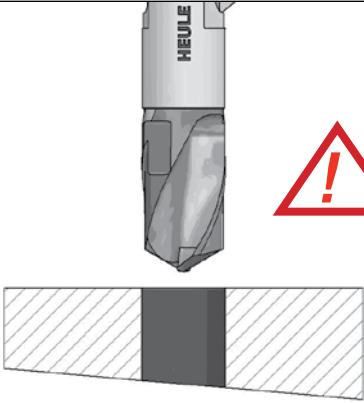
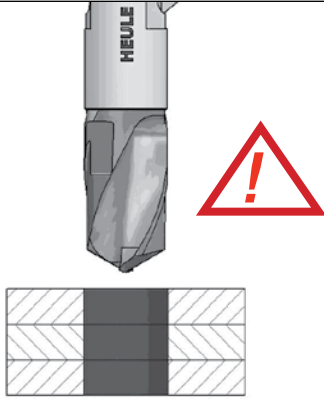
 <p style="text-align: right; color: red; font-weight: bold; font-size: 24px;">ok</p>	 <p style="text-align: right; color: red; font-weight: bold; font-size: 24px;">ok</p>	
<p>Drilling of even machined surfaces.</p>	<p>Drilling on central or convex surfaces.</p>	<p>Drilling on uneven surfaces. If necessary reduce feed-rate.*</p>
		
<p>Drilling on angled surfaces.*</p>	<p>Drilling on off-center convex or concave surfaces.*</p>	<p>Drilling on uneven surface in forged or cast iron: Not possible.</p>
		
<p>Drilling through a cross-hole. Ø cross-hole max. 0.5x Ø bore. If necessary reduce feed rate.**</p>	<p>Drilling with angle on back side. Reduce feed rate to about 50-60%*</p>	<p>Drilling through several layers. Seamless fitting of the different workpieces is necessary.</p>

*Chamfer won't be clean.

**Tool can break! Chamfer blade can get stuck in the cross-hole (drive through the bore with no rotation of the tool!)



Grinding may produce hazardous dust. To avoid adverse effects, use adequate ventilation and read MSDS. Cutting tools may break during use. To avoid injury, use proper safety precautions and protective equipment. Use the machine tool with sufficient rigidity and horsepower. Use a cover on a machine tool and protector, such as glasses, against shattering chips and broken tools due to misuse. Do not use insoluble oil because there is a danger of causing fire.



Visit our website for our full line
of product brochures and videos

www.HeuleTool.com

We provide online tool selectors for the
COFA, **SNAP**, **DEFA** and **BSF** product groups.

Simply enter your application information and the correct tool will
be provided complete with order number and sample drawing.

We are also available on:



VEX-P

Combination of Drilling and Front and Back Chamfering in One Operation.

- High performance replaceable carbide drill tip combined with patented SNAP chamfering system
- VEX drill geometry for better chip control
- Quick and easy drill tip and chamfer blade replacement
- Coolant Through
- Sizes 11.0-17.0mm (.433-.669") available from stock

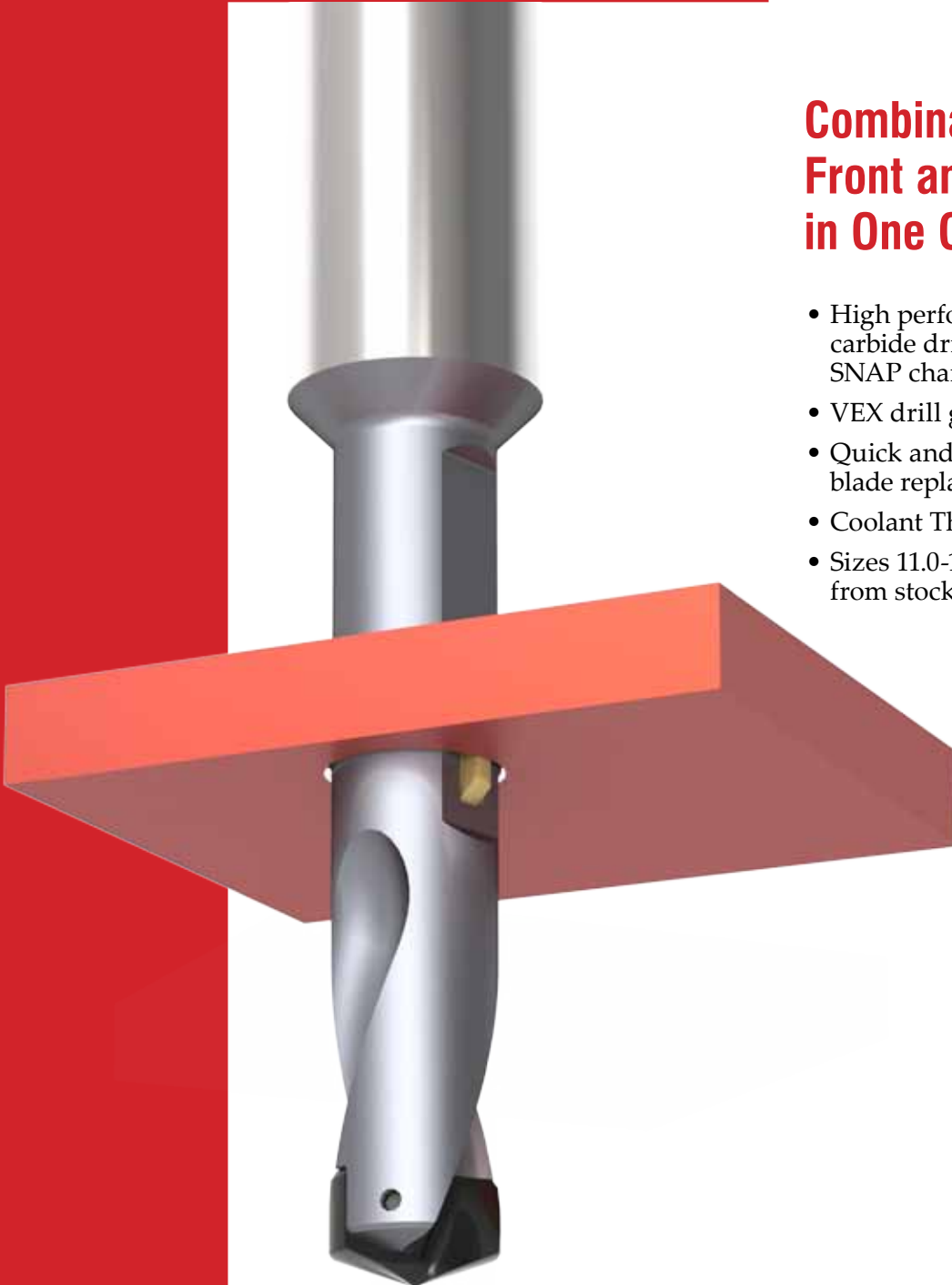

HTC015

COFA | SNAP | VEX-S | VEX-P | COMBI | DEFA | GH-K | BSF | SOLO | GH-Z/E

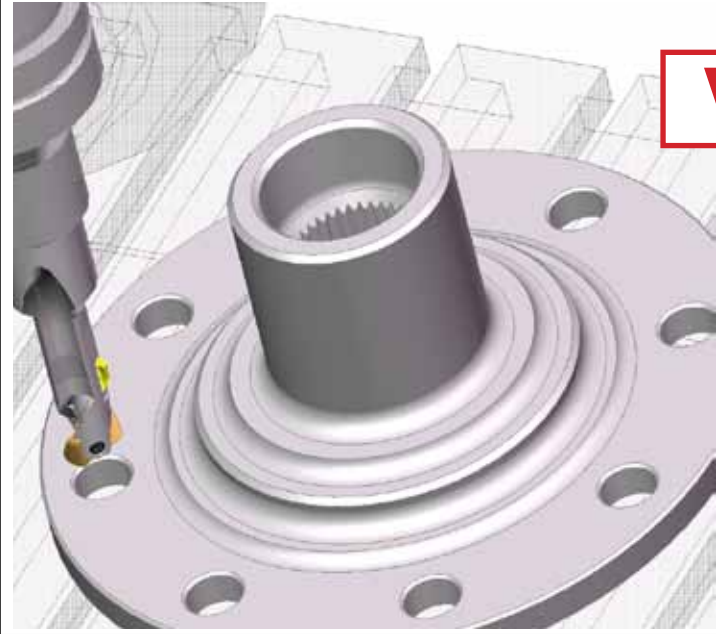

VEX-P

Combination of Drilling and Front/Back Chamfering in One Operation.

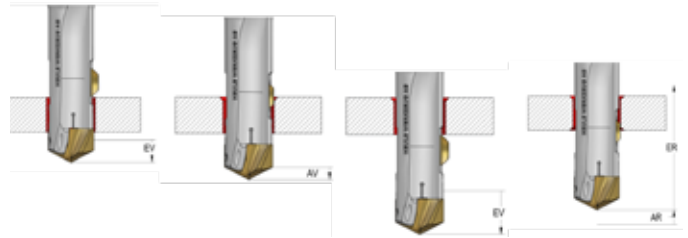

Study Details



TOOL
VEX-P

PRODUCTION
30,000 parts per month

MACHINE
Vertical CNC

MATERIAL
1050 Steel

HOLE SIZE
Ø13.0mm (.512") drilled front and back chamfered in one single operation

DETAILS
Tool:
Speed: VEX-P SNAP12 drill combi
Feed: 3720 RPM 500 SFM
VEX: 0.25 mm/rev (.0101" IPR)
Life: SNAP: 0.20 mm/rev (.008" IPR)
VEX: 4,500 holes/
SNAP: 13,500 holes

REPLACING
Solid carbide and secondary operation

The VEX-P tool combines a replaceable solid carbide high performance drill tip with HEULE's patented SNAP chamfering system to enable drilling and front and back chamfering in one operation.

"The Vex-P combination tool replaced two tools and cut our cycle time in half for that operation..."

For bores from diameters 11.00 mm to 17.0 mm (0.433 - 0.669") and bore depths up to 1.5 times diameter.



How to Select a VEX-P Tool

1. Determine the drill hole size.
2. Select the appropriate drill tip and the coordinating tool holder.
3. Choose the SNAP chamfer blade according to the needed chamfer size.

1 Series

Bore Range	Series
11.0-13.99	C
14.0-17.0	D

2 Bore Diameter Ød

Indicate the bore diameter here. For example: Ø15.10 = 1510
Standard size as shown.

3 Cutting Material

Carbide K20-K30	1
-----------------	---

4 Coating

TiAlN	A
DLC	D

Within the holder range, drill tips of different diameters can be exchanged within the same series number.

Tool Description

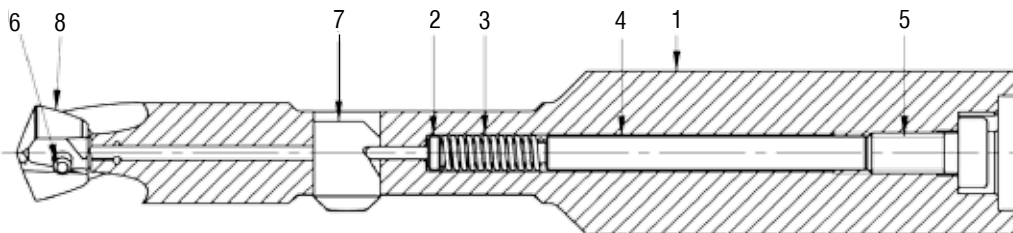

- 1 Tool Body
- 2 Control Bolt
- 3 Spring
- 4 Distance Pin
- 5 Cap Screw
- 6 Torx Screw
- 7 Chamfer Blade
- 8 Drill Tip

Order Number Example: P- P- D 1450 -1 A

- 1 = Series
- 2 = Bore-Ød
- 3 = Cutting Material
- 4 = Coating

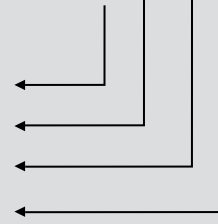

Order Example:

Bore-Ød	= 14.50mm
Carbide Quality	= K20-K30
Coating	= TiAlN
Order Number: P-P-D-1450-1A	



Spare Parts

Bore Range	Series	2 Control Bolt	3 Spring	4 Distance Pin	5 Cap Screw GH-H-S-	Hex Wrench GH-H-S-	Hex Wrench Description mm
11.0 - 11.99	C	GH-Q-E-0078	GH-H-F-0027	GH-Q-E-0503	0538-1	2100	2.5
12.0 - 13.99	C	GH-Q-E-0002	GH-H-F-0012	GH-Q-E-0514	0524-1	2103	3.0
14.0 - 15.49	D	GH-Q-E-0002	GH-H-F-0012	GH-Q-E-0514	0524-1	2103	3.0
15.5 - 17.0	D	GH-Q-E-0002	GH-H-F-0012	GH-Q-E-0515	0524-1	2103	3.0

Bore Range	Series	6 Torx Screw	Clamp Screw Description	Torx Wrench GH-H-S-	Torque Setting Nm	<i>Recommended</i> Precision Torque Wrench Wrench Order # Description	
11.0 - 11.99	C	GH-H-S-0038	M2.2 x 10.2 T7	2001	1.1	HT-TX-H-0002	Handle 1.1 NM with IP7 Torx Bit
12.0 - 13.99	C	GH-H-S-0038	M2.2 x 10.2 T7	2001	1.1		
14.0 - 15.49	D	GH-H-S-0035	M2.5 x 12 T8	2002	1.2	HT-TX-H-0003	Handle 1.2 NM with T8 Torx Bit
15.5 - 17.0	D	GH-H-S-0035	M2.5 x 12 T8	2002	1.2		

HTC015

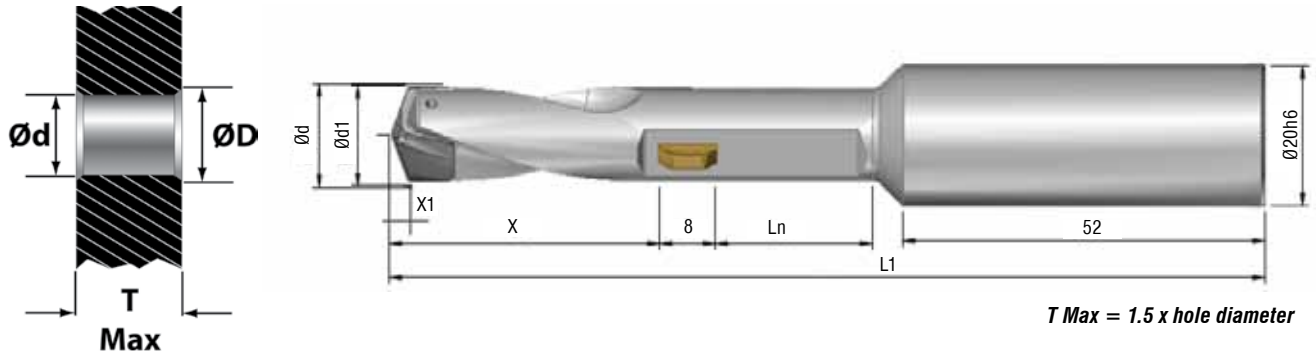

VEX-P Series C Tool Holders Ødx1.5 with Coolant Through

Tool Holder Order Number	Ød Range	Ød1	L1	Ln	X1	X
GH-Q-O-4250E	11.0 – 11.4	10.8 (.425")	116.9 (4.602")	17.2 (.677")	2.5 (.099")	33.5 (1.319")
GH-Q-O-4251E	11.5 – 11.9	11.3 (.445")	118.2 (4.654")	18.0 (.709")	2.6 (.102")	34.3 (1.350")
GH-Q-O-4252E	12.0 – 12.4	11.8 (.465")	119.4 (4.701")	18.7 (.736")	2.7 (.106")	35.1 (1.382")
GH-Q-O-4253E	12.5 – 12.9	12.3 (.484")	120.7 (4.752")	19.5 (.768")	2.8 (.110")	35.8 (1.409")
GH-Q-O-4254E	13.0 – 13.4	12.8 (.504")	121.9 (4.799")	20.2 (.795")	2.9 (.114")	36.6 (1.441")
GH-Q-O-4255E	13.5 – 13.9	13.3 (.524")	123.2 (4.850")	21.0 (.827")	3.0 (.118")	37.3 (1.469")

VEX-P Series C Drills & Chamfer Blades

Ød Drill*	Tool Holder Order Number	Carbide TiAlN Drill Order #	Cmf. Series	Chamfer Blade Order Number (fab)*			
				(0.25mm x 45°) GH-Q-M-	(0.5mm x 45°) GH-Q-M-	(0.75mm x 45°) GH-Q-M-	(1.0mm x 45°) GH-Q-M-
11.0mm (.433")	GH-Q-O-4250E	P-P-C-1100-1A	8	-03726 (11.5)	-03727 (12.0)	-03728 (12.5)	-
11.1mm (.437")	GH-Q-O-4250E	P-P-C-1110-1A		-03727 (12.0)	-03728 (12.5)	-03729 (13.0)	-
11.5mm (.453")	GH-Q-O-4251E	P-P-C-1150-1A		-03727 (12.0)	-03728 (12.5)	-03729 (13.0)	-
11.9mm (.469")	GH-Q-O-4251E	P-P-C-1190-1A		-03728 (12.5)	-03729 (13.0)	-03730 (13.5)	-
12.0mm (.472")	GH-Q-O-4252E	P-P-C-1200-1A	12	-03740 (12.5)	-03741 (13.0)	-03742 (13.5)	-03743 (14.0)
12.5mm (.492")	GH-Q-O-4253E	P-P-C-1250-1A		-03741 (13.0)	-03742 (13.5)	-03743 (14.0)	-03744 (14.5)
12.7mm (.500")	GH-Q-O-4253E	P-P-C-1270-1A		-03741 (13.0)	-03742 (13.5)	-03743 (14.0)	-03744 (14.5)
13.0mm (.511")	GH-Q-O-4254E	P-P-C-1300-1A		-03742 (13.5)	-03743 (14.0)	-03744 (14.5)	-03745 (15.0)
13.5mm (.531")	GH-Q-O-4255E	P-P-C-1350-1A		-03743 (14.0)	-03744 (14.5)	-03745 (15.0)	-03746 (15.5)

*Special sizes and geometries available on request

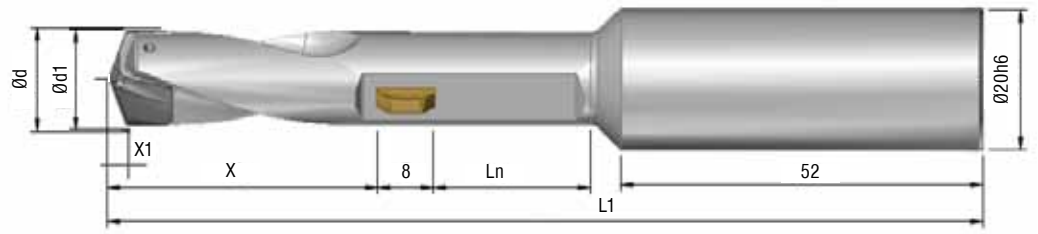
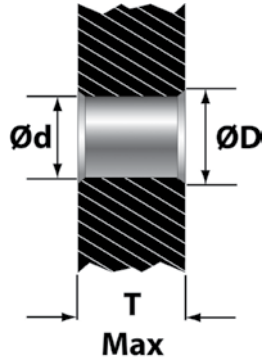

T Max = 1.5 x hole diameter

VEX-P Series D Tool Holders Ødx1.5 with Coolant Through

Tool Holder Order Number	Ød Range	Ød1	L1	Ln	X1	X
GH-Q-0-4256E	14.0 – 14.4	13.8 (.543")	123.4 (4.858")	21.7 (.854")	3.1 (.122")	37.1 (1.461)
GH-Q-0-4257E	14.5 – 14.9	14.3 (.563")	124.7 (4.909")	22.5 (.886")	3.2 (.126")	37.8 (1.488)
GH-Q-0-4258E	15.0 – 15.4	14.8 (.583")	125.9 (4.957")	23.2 (.913")	3.3 (.130")	38.6 (1.520)
GH-Q-0-4259E	15.5 – 15.9	15.3 (.602")	127.2 (5.008")	24.0 (.945")	3.4 (.134")	39.3 (1.547)
GH-Q-0-4260E	16.0 – 16.4	15.8 (.622")	128.4 (5.055")	24.7 (.972")	3.5 (.138")	40.1 (1.579)
GH-Q-0-4261E	16.5 – 17.0	16.3 (.642")	129.7 (5.106")	25.5 (1.004")	3.6 (.142")	40.8 (1.606)

VEX-P Series D Drills & Chamfer Blades

Ød Drill*	Tool Holder Order Number	Carbide TiAlN Drill Order #	Cmf. Series	Chamfer Blade Order Number (fab)*			
				(0.25mm x 45°) GH-Q-M-	(0.5mm x 45°) GH-Q-M-	(0.75mm x 45°) GH-Q-M-	(1.0mm x 45°) GH-Q-M-
14.0mm (.551")	GH-Q-0-4256E	P-P-D-1400-1A	12	-03744 14.5	-03745 15.0	-03746 15.5	-03747 16.0
14.3mm (.562")	GH-Q-0-4256E	P-P-D-1430-1A		-03744 14.5	-03745 15.0	-03746 15.5	-03747 16.0
14.5mm (.571")	GH-Q-0-4257E	P-P-D-1450-1A		-03745 15.0	-03746 15.5	-03747 16.0	-03748 16.5
15.0mm (.591")	GH-Q-0-4258E	P-P-D-1500-1A		-03746 15.5	-03747 16.0	-03748 16.5	-03749 17.0
15.5mm (.610")	GH-Q-0-4259E	P-P-D-1550-1A		-03747 16.0	-03748 16.5	-03749 17.0	-03750 17.5
15.9mm (5/8")	GH-Q-0-4259E	P-P-D-1590-1A		-03747 16.5	-03749 17.0	-03750 17.5	-03751 18.0
16.0mm (.630")	GH-Q-0-4260E	P-P-D-1600-1A		-03748 16.5	-03749 17.0	-03750 17.5	-03751 18.0
16.5mm (.650")	GH-Q-0-4261E	P-P-D-1650-1A		-03749 17.0	-03750 17.5	-03751 18.0	-03752 18.5
17.0mm (.669")	GH-Q-0-4261E	P-P-D-1700-1A		-03750 17.5	-03751 18.0	-03752 18.5	-03753 19.0

*Special sizes available on request

PROGRAMMING PG. 111
CHANGE BLADES PG. 112

VEX-P Speeds and Feeds

IMPORTANT: Cutting data is for guidance only and based on recommended values, assuming ideal conditions. Cutting data may need to be adjusted subject to the application settings, machining or consistency of the workpiece.

Material	Hardness HB	SFM	IPR Ø11-13.9	IPR Ø14-16.9
Alloy Steel	280-415	130-300	.005-.009	.007-.012
Med Carbon Steel	300-450	300-425	.006-.012	.008-.014
Free machining steel	425-550	220-450	.006-.012	.007-.013
Low-Carbon steel	350-520	250-490	.007-.012	.008-.014
Cast steel		150-250	.004-.008	.006-.012
High-alloy steel	100-130	100-220	.005-.010	.006-.012
Tool steel	205-265	120-210	.005-.008	.007-.010
Hardened steel	120-155	65-130	.004-.006	.005-.008
Chilled castings*	80-145	65-145	.004-.006	.005-.008
Stainless steel*	100-240	80-210	.004-.008	.005-.008
Titanium*	100-140	90-130	.004-.006	.005-.008
Grey cast iron	335-500	300-590	.010-.014	.013-.020
Nodular cast iron	335-500	335-525	.008-.013	.011-.019
Aluminium**	1000-1400	400-1000	.010-.016	.011-.016
Aluminum-casting alloys**	75-1000	300-800	.010-.015	.013-.018
Brass	660	300-500	.010-.014	.015-.016
Copper alloys	425	300-460	.004-.010	.006-.012
Bronze-Short Chipping	295-360	295-360	.012-.014	.015-.016
Bronze-Long Chipping		130-200	.006-.012	.006-.015

Note: Carbide - TiAlN/TiN (drill and chamfer) recommendation

*Optional geometry available on request, contact Heule Tool Engineering

**Recommend DLC coating

VEX-P Programming Sequence

It is not necessary to change the direction of rotation or stop the spindle

WF: Working feed

RF: Rapid feed

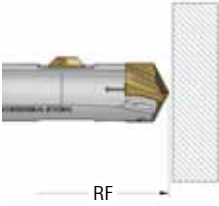
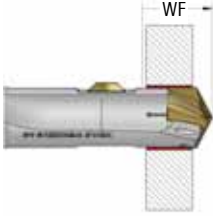
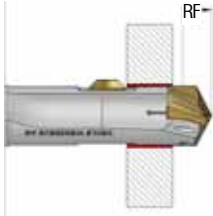
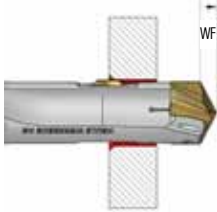
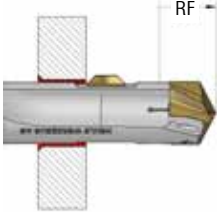
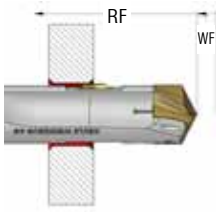
	<p>Step 1: Rapid feed of the tool to within clearance for the work piece</p>
	<p>Step 2: With forward working feed, feed the tool through the workpiece until the hole is drilled and the drill tip is clear of the bore.</p>
	<p>Step 3: Rapid feed the tool so the SNAP blade is within clearance of the workpiece top surface or burr.</p> <p>Note: Clearance distance (+1.0mm/0.04")</p>
	<p>Step 4: With working feed, cut the top chamfer. Continue feeding until the SNAP blade is completely retracted into the tool body.</p>
	<p>Step 5: Use rapid feed to position the SNAP blade on the far side of the part. Position the tool so the SNAP blade is completely extended and clear of the part or burr.</p>
	<p>Step 6: With back working feed, cut the back chamfer. When the SNAP blade is completely within the tool and clear of the back surface, the tool can be extracted with rapid feed.</p>

How to Replace the Snap Chamfer Blade

Step 1:

Turn cap screw counterclockwise approximately 3-5 turns.

Step 2:

Remove the blade by simply pushing it past center and out the back of the tool.

Step 3:

Install the new blade by pushing the back side of the blade through the window until it “snaps”. Retighten screw clockwise. Check to make sure blade moves freely.

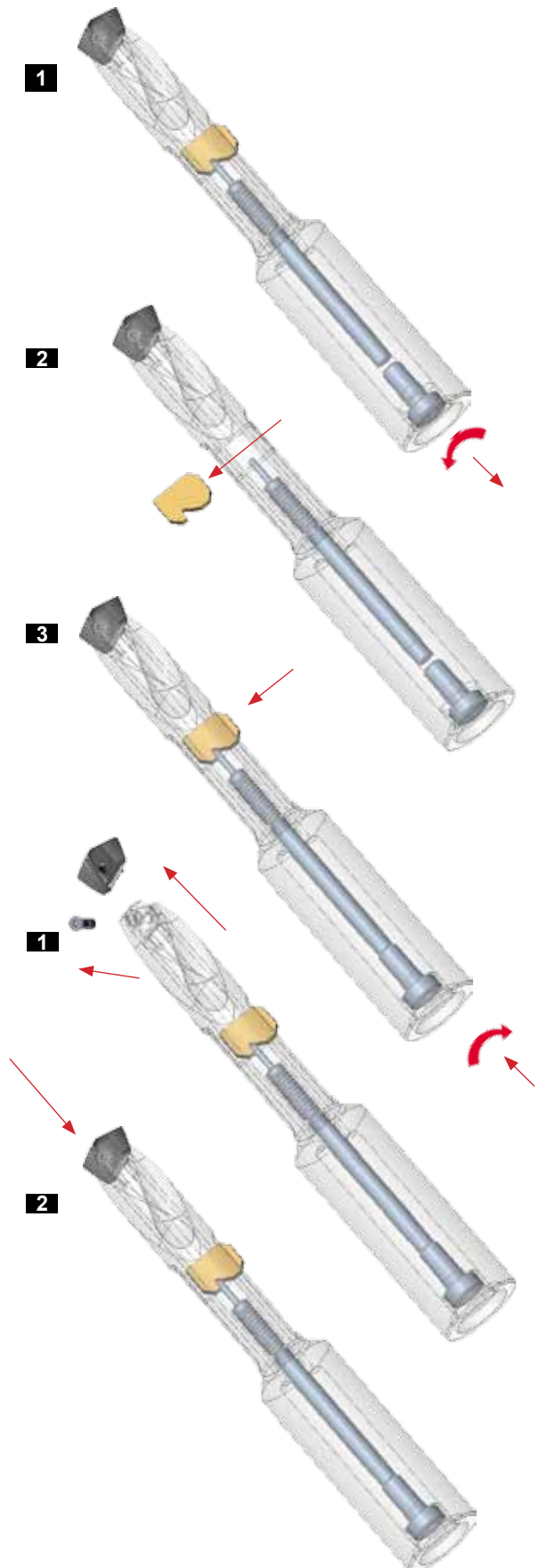

How to Replace the Drill Tip

Step 1:

Use Torx wrench to remove drill tip. Clean the drill connection.

Step 2:

Insert new drill tip and screw into holder. Tighten screw to recommended torque setting.

COMBI



Combination Drill with Front & Back Chamfering of Through Holes

- Save time and money by combining operations
- Ideal for automotive applications – wheels, brake discs
- Custom tooling options available for various multi-task operations
- Available in sizes 9.5-35mm

The HEULE COMBI tool is a unique innovation combining the proven throw-away style drill blades with HEULE's patented SNAP chamfering system to create a single tool. Simple tools combine drilling and chamfering, complex tools combine drilling, chamfering, countersinking, and spotfacing. This tool offers several machining operations in one machine cycle saving time, money, and space.

Combines Operations

The HEULE COMBI tool combines operations into one tool to reduce tool changes and cycle time, which saves time, money, and space. Reducing cycle time which will boost production and allow a competitive advantage. With HEULE's proven SNAP chamfering system, the COMBI tool provides high quality consistent chamfers on every bore.

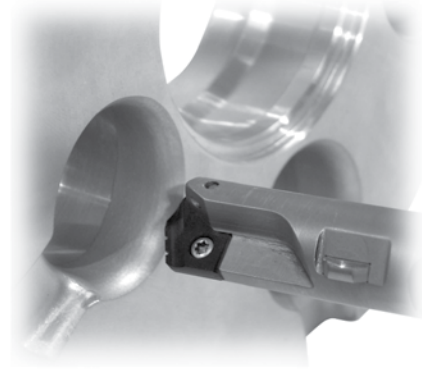

Ideal for Automotive Industry

The HEULE COMBI tool has proven very effective in the automotive industry, particularly with wheel, axle and brake disc applications. The tool design and function are well suited for high production environments and the proven drilling and SNAP chamfering systems provide consistent, high quality results.



Custom Tooling Options

The HEULE COMBI tool design provides the ability to create custom tooling for almost any application. The COMBI standard drilling range is 9.5-35mm (.374-1.378") and design options can combine drilling, spotfacing, and countersinking with chamfering or back chamfering only. Through coolant is available, as well as varied lengths to improve rigidity or meet specific application needs.

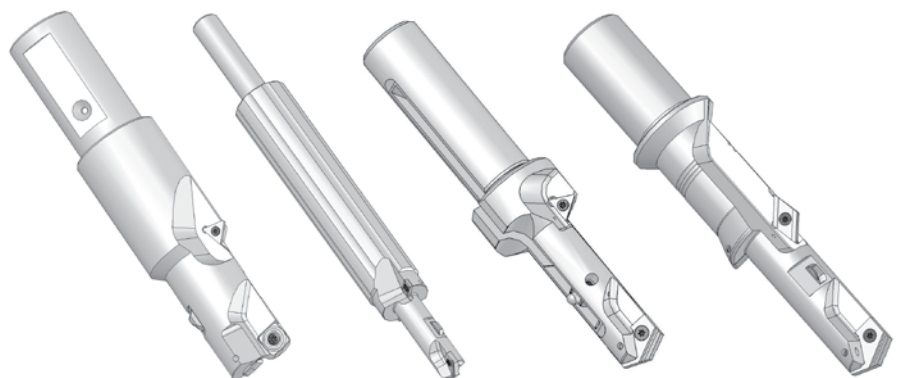

How Does It Work?

The Combi tool uses a standard spade drill and SNAP Chamfer Blade to create drilled holes that are chamfered and deburred on the front and back of the work piece in one operation.

The drill forward feeds completely through the work piece until the spade drill insert clears the part. Then rapid feed so the SNAP blade is within clearance of the top of the part. Feed the tool forward to produce the front chamfer. When the SNAP blade is retracted in the hole, only the ground sliding surface touches the hole protecting it from damage while the tool is fed through the part in rapid feed. There is no stopping or reversing the spindle.

When the blade reaches the back of the part past the burr the chamfer blade extends to the cutting position and then the tool is retracted with the same working feed and speed. When the blade is again in the hole, the tool can be rapid fed out and on to the next hole. Standard Countersink Combi tools add pocket ISO inserts to the tool body to create large front countersinks.

Typical Parts



How to Order:

1 Series

Bore Range Ød	Series
9.5 - 11.0	Y
11.1 - 12.9	Z
13.0 - 17.6	0
17.7 - 24.3	1
24.4 - 35.0	2

2 Bore Diameter Ød

Indicate the bore diameter here.
For example: Ø9.50 = 0950
Standard size as shown.

3 Cutting Material

HSS	1
C2 Carbide	2
C5 Carbide	3

4 Coating

Ucoated	U
TiN	T
TiAlN	A
DLC	D

Order Number Example:

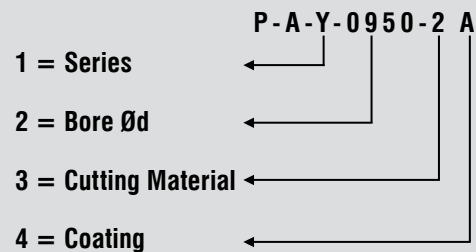

Sample:

Bore-Ød	= 9.50mm
Carbide Quality	= C2 Carbide
Coating	= TiAlN

Order Number: P-A-Y-0950-2A

HTC015

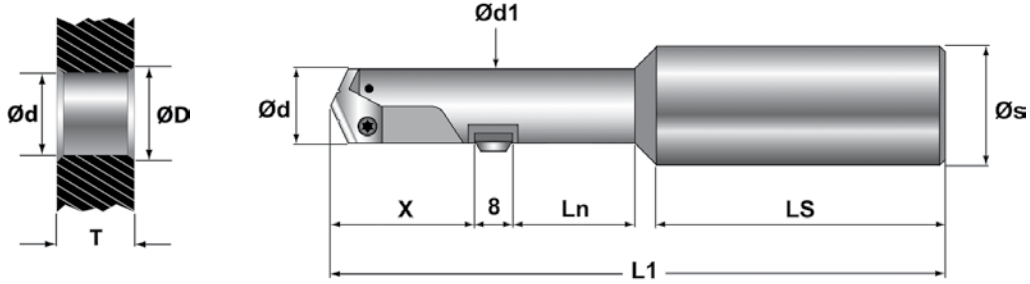

COMBI Drill Chamfer Tools Ø9.5-Ø17.99mm with coolant through

Series	Tool Holder Order Number	Ød Range mm	T	Ød1	X	L1	Ln	LS	Øs
Y	GH-Q-O-3441	9.5 - 10.4	12 (.472")	9.4 (.370")	21.3 (.839")	102.3 (4.028")	17 (.669")	50 (1.969")	20 (.787")
	GH-Q-O-3445	10.5 - 11.4	12 (.472")	10.0 (.394")	21.3 (.839")	102.3 (4.028")	17 (.669")		
Z	GH-Q-O-3449	11.5 - 11.9	12 (.472")	10.8 (.425")	21.3 (.839")	102.3 (4.028")	17 (.669")		
	GH-Q-O-3453	12.0 - 12.9	14 (.551")	11.8 (.465")	24.3 (.957")	104.8 (4.126")	18 (.709")		

Chamfer Blade Options

Series	Ød Drill* mm inches	Tool Holder ¹ Order Number	Drill Tip Order Number	Cmt. Series	Blade, Carbide-TiN, 90°, front and back** Order Number (Chamfer ØD mm)			
					(0.25mm x 45°) GH-Q-M-	(0.5mm x 45°) GH-Q-M-	(0.75mm x 45°) GH-Q-M-	(1.0mm x 45°) GH-Q-M-
Y	9.53 .375	GH-Q-O-3441	P-A-Y-0953-2A	8	-03723 (10.0)	-03724 (10.5)	-03725 (11.0)	-
	10.0 .394	GH-Q-O-3441	P-A-Y-1000-2A		-03724 (10.5)	-03725 (11.0)	-03726 (11.5)	-
	10.32 13/32"	GH-Q-O-3445	P-A-Y-1032-2A		-03725 (11.0)	-03726 (11.5)	-03727 (12.0)	-
	10.5 .413	GH-Q-O-3445	P-A-Y-1050-2A		-03725 (11.0)	-03726 (11.5)	-03727 (12.0)	-
	11.0 .433	GH-Q-O-3445	P-A-Y-1100-2A		-03726 (11.5)	-03727 (12.0)	-03728 (12.5)	-
Z	11.1 7/16"	GH-Q-O-3449	P-A-Z-1110-2A	12	-03726 (11.5)	-03727 (12.0)	-03728 (12.5)	-
	11.5 .453	GH-Q-O-3449	P-A-Z-1150-2A		-03727 (12.0)	-03728 (12.5)	-03729 (13.0)	-
	11.91 15/32"	GH-Q-O-3449	P-A-Z-1191-2A		-03728 (12.5)	-03729 (13.0)	-03730 (13.5)	-
	12.0 .472	GH-Q-O-3453	P-A-Z-1200-2A		-03740 (12.5)	-03741 (13.0)	-03742 (13.5)	-03743 (14.0)
	12.5 .492	GH-Q-O-3453	P-A-Z-1250-2A		-03741 (13.0)	-03742 (13.5)	-03743 (14.0)	-03744 (14.5)
	12.7 1/2"	GH-Q-O-3453	P-A-Z-1270-2A		-03742 (13.5)	-03743 (14.0)	-03744 (14.5)	-03745 (15.0)

* Non-stock standard item with extended delivery time. Spade drill 10 piece minimum.

Other drill sizes available upon request. Example: Ød = 13.75mm (.541") - P-A-O-1375-2A.

** Chamfer blades are interchangeable; maximum chamfer diameter ØD = hole Ød + 1.5mm (series 8)/2.0mm (series 12).

¹ Non-stock standard item with extended delivery time.

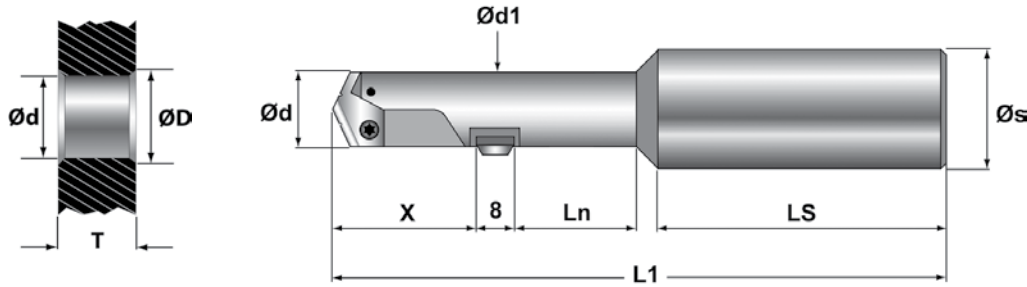

COMBI Drill Chamfer Tools Ø9.5-Ø17.99mm with coolant through

Series	Tool Holder Order Number	Ød Range mm	T	Ød1	X	L1	Ln	Ls	Øs
0	GH-Q-0-3457S	13.0 - 14.9	16 (.630")	12.8 (.504")	26.8 (1.055")	107.3 (4.224")	18 (.709")	50 (1.969")	20 (.787")
	GH-Q-0-3461S	15.0 - 17.9	18 (.709")	14.8 (.583")	29.8 (1.173")	115.8 (4.560")	24 (.945")		

Chamfer Blade Options

Series	Ød Drill* mm inches	Tool Holder ¹ Order Number	Drill Tip Order Number	Cmf. Series	Blade, Carbide-TiN, 90°, front and back** Order Number (Chamfer ØD mm)			
					(0.25mm x 45°) GH-Q-M-	(0.5mm x 45°) GH-Q-M-	(0.75mm x 45°) GH-Q-M-	(1.0mm x 45°) GH-Q-M-
0	13.0 .511	GH-Q-0-3457S	P-A-0-1300-2A	12	-03742 (13.5)	-03743 (14.0)	-03744 (14.5)	-03745 (15.0)
	13.5 .531	GH-Q-0-3457S	P-A-0-1350-2A		-03743 (14.0)	-03744 (14.5)	-03745 (15.0)	-03746 (15.5)
	14.0 .551	GH-Q-0-3457S	P-A-0-1400-2A		-03744 (14.5)	-03745 (15.0)	-03746 (15.5)	-03747 (16.0)
	14.29 9/16"	GH-Q-0-3457S	P-A-0-1429-2A		-03745 (15.0)	-03746 (15.5)	-03747 (16.0)	-03748 (16.5)
	14.5 .571	GH-Q-0-3457S	P-A-0-1450-2A		-03745 (15.0)	-03746 (15.5)	-03747 (16.0)	-03748 (16.5)
	15.0 .591	GH-Q-0-3461S	P-A-0-1500-2A		-03746 (15.5)	-03747 (16.0)	-03748 (16.5)	-03749 (17.0)
	15.5 .610	GH-Q-0-3461S	P-A-0-1550-2A		-03747 (16.0)	-03748 (16.5)	-03749 (17.0)	-03750 (17.5)
	15.88 5/8"	GH-Q-0-3461S	P-A-0-1588-2A		-03748 (16.5)	-03749 (17.0)	-03750 (17.5)	-03751 (18.0)
	16.0 .630	GH-Q-0-3461S	P-A-0-1600-2A		-03748 (16.5)	-03749 (17.0)	-03750 (17.5)	-03751 (18.0)
	16.5 .650	GH-Q-0-3461S	P-A-0-1650-2A		-03749 (17.0)	-03750 (17.5)	-03751 (18.0)	-03752 (18.5)
	17.0 .669	GH-Q-0-3461S	P-A-0-1700-2A		-03750 (17.5)	-03751 (18.0)	-03752 (18.5)	-03753 (19.0)
	17.46 11/16"	GH-Q-0-3461S	P-A-0-1746-2A		-03751 (18.0)	-03752 (18.5)	-03753 (19.0)	-03754 (19.5)

* Non-stock standard item with extended delivery time. Spade drill 10 piece minimum.

Other drill sizes available upon request. Example: Ød = 13.75mm (.541") - P-A-0-1375-2A.

** Chamfer blades are interchangeable; maximum chamfer diameter ØD = hole Ød + 1.5mm (series 8)/2.0mm (series 12).

¹ Non-stock standard item with extended delivery time.

HTC015

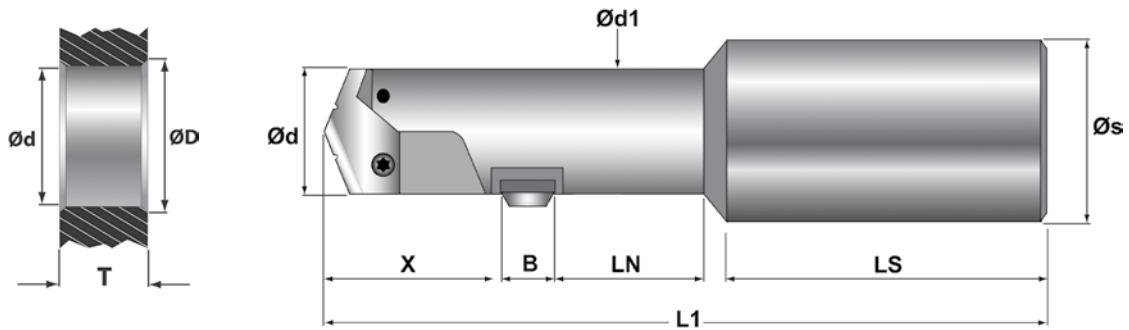

COMBI Drill Chamfer Tools Ø18.0-Ø35.0mm with Coolant Through

Series	Tool Holder Order Number	Ød Range mm	T	Ød1	B	X	L1	Ln	Ls	Øs
1	GH-Q-0-3465S	18.0 - 19.9	20 (.787")	17.5 (.689")	8 (.315")	34.6 (1.362")	125.6 (4.945")	22 (.866")	56 (2.205")	25 (.984")
	GH-Q-0-3469S	20.0 - 24.9	24 (.945")	19.8 (.780")	8 (.315")	39.6 (1.559")	136.6 (5.378")	28 (1.102")	56 (2.205")	25 (.984")

COMBI Series 1 Chamfer Drill and Chamfer Blades

Series	Ød Drill mm inches	Tool Holder ¹ (with coolant)	Drill Tip Order Number	Cmf. Series	Blade, Carbide-TiN, 90°, front and back Order Number (Chamfer ØD mm)		
					(0.5mm x 45°) GH-Q-M-	(0.75mm x 45°) GH-Q-M-	(1.0mm x 45°) GH-Q-M-
1	18.0 .709	GH-Q-0-3465S	P-A-1-1800-2A	12	-03753 (19.0)	-03754 (19.5)	-03755 (20.0)
	18.5 .728	GH-Q-0-3465S	P-A-1-1850-2A		-03754 (19.5)	-03755 (20.0)	-03756 (20.5)
	19.05 3/4"	GH-Q-0-3465S	P-A-1-1905-2A		-03755 (20.0)	-03756 (20.5)	-03757 (21.0)
	19.50 .768	GH-Q-0-3465S	P-A-1-1950-2A		-03756 (20.5)	-03757 (21.0)	-03758 (21.5)
	20.0 .787	GH-Q-0-3469S	P-A-1-2000-2A	20	-03770 (21.0)	-03771 (22.0)	-03772 (23.0)
	21.0 .827	GH-Q-0-3469S	P-A-1-2100-2A		-03771 (22.0)	-03772 (23.0)	-03773 (24.0)
	22.0 .866	GH-Q-0-3469S	P-A-1-2200-2A		-03772 (23.0)	-03773 (24.0)	-03774 (25.0)
	23.0 .906	GH-Q-0-3469S	P-A-1-2300-2A		-03773 (24.0)	-03774 (25.0)	-03775 (26.0)
	24.0 .945	GH-Q-0-3469S	P-A-1-2400-2A		-03774 (25.0)	-03775 (26.0)	-03776 (27.0)

* Non-stock standard item with extended delivery time. Spade drill 10 piece minimum. Other drill sizes available upon request. Example: Ød = 26.5mm (1.043") - P-A-2-2650-2A.

** Chamfer blades are interchangeable; maximum chamfer diameter ØD = hole Ød + 2mm.

¹ Non-stock standard item with extended delivery time.

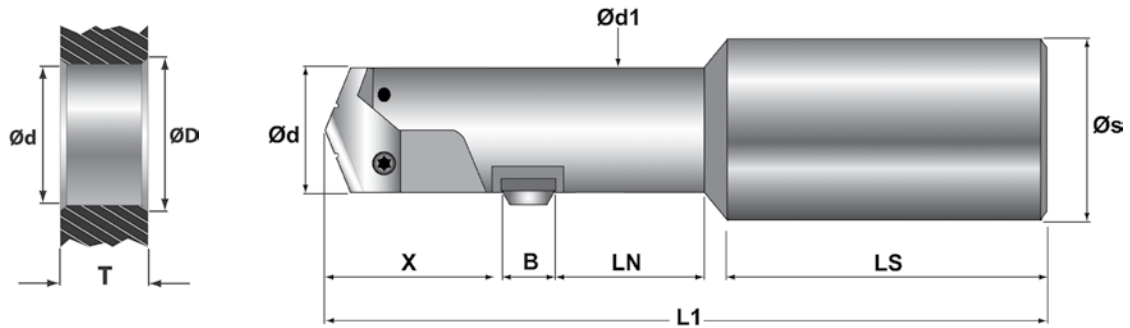

COMBI Drill Chamfer Tools Ø18.0-Ø35.0mm with Coolant Through

Series	Tool Holder Order Number	Ød Range mm	T	Ød1	B	X	L1	Ln	Ls	Øs
2	GH-Q-0-3473S	25.0 - 29.9	30 (1.181")	24.2 (.953")	10 (.394")	48.6 (1.913")	155.6 (6.126")	32 (1.260")	60 (2.362")	32 (1.260")
	GH-Q-0-3477S	30.0 - 34.9	38 (1.496")	29.8 (1.173")	10 (.394")	59.6 (2.346")	171.6 (6.756")	40 (1.575")	60 (2.362")	32 (1.260")

COMBI Series 2 Chamfer Drill and Chamfer Blades

Series	Ød Drill mm inches	Tool Holder ¹ (with coolant)	Drill Tip Order Number	Cmf. Series	Blade, Carbide-TiN, 90°, front and back Order Number (Chamfer ØD mm)		
					(0.5mm x 45°) GH-Q-M-	(1.0mm x 45°) GH-Q-M-	(1.5mm x 45°) GH-Q-M-
2	25.0 .984	GH-Q-0-3473S	P-A-2-2500-2A	20	-03775 (26.0)	-03776 (27.0)	-03777 (28.0)
	25.4 1.00	GH-Q-0-3473S	P-A-2-2540-2A		-03775 (26.0)	-03776 (27.0)	-03777 (28.0)
	26.0 1.023	GH-Q-0-3473S	P-A-2-2600-2A		-03776 (27.0)	-03777 (28.0)	-03778 (29.0)
	27.0 1.063	GH-Q-0-3473S	P-A-2-2700-2A		-03777 (28.0)	-03778 (29.0)	-03779 (30.0)
	28.0 1.102	GH-Q-0-3473S	P-A-2-2800-2A		-03778 (29.0)	-03779 (30.0)	-03780 (31.0)
	29.0 1.141	GH-Q-0-3473S	P-A-2-2900-2A		-03779 (30.0)	-03780 (31.0)	-03781 (32.0)
	30.0 1.181	GH-Q-0-3477S	P-A-2-3000-2A		-03780 (31.0)	-03781 (32.0)	-03782 (33.0)
	31.0 1.220	GH-Q-0-3477S	P-A-2-3100-2A		-03780 (31.0)	-03781 (32.0)	-03782 (33.0)
	31.75 1 1/4"	GH-Q-0-3477S	P-A-2-3175-2A		-03781 (32.0)	-03782 (33.0)	-03783 (34.0)
	32.0 1.260	GH-Q-0-3477S	P-A-2-3200-2A		-03782 (33.0)	-03783 (34.0)	-03784 (35.0)
	33.0 1.300	GH-Q-0-3477S	P-A-2-3300-2A		-03783 (34.0)	-03784 (35.0)	-03785 (36.0)
	34.0 1.339	GH-Q-0-3477S	P-A-2-3400-2A		-03784 (35.0)	-03785 (36.0)	-03786 (37.0)
	35.0 1.378	GH-Q-0-3477S	P-A-2-3500-2A		-03785 (36.0)	-03786 (37.0)	-03787 (38.0)

* Non-stock standard item with extended delivery time. Spade drill 10 piece minimum. Other drill sizes available upon request. Example: Ød = 26.5mm (1.043") - P-A-2-2650-2A.

** Chamfer blades are interchangeable; maximum chamfer diameter ØD = hole Ød + 2mm.

¹ Non-stock standard item with extended delivery time.

HTC015

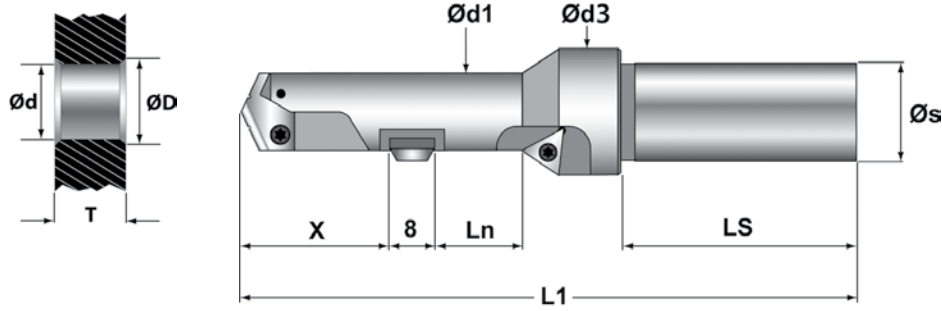

COMBI Drill Chamfer Tools Ø9.5-Ø17.99mm with Coolant Through

Series	Tool Holder Order Number	Ød Range mm	T	Ød1	Ød3	X	L1	Ln	Ls	Øs
Y	GH-Q-O-3641	9.5 - 9.9	12 (.472")	9.4 (.370")	20.0 (.787")	21.3 (.839")	112.3 (4.421")	12.2 (.480")	48 (1.890")	16 (.630")
	GH-Q-O-3645	10.0 - 10.4	12 (.472")	10.0 (.394")	20.0 (.787")	21.3 (.839")	112.3 (4.421")	12.4 (.488")	48 (1.890")	16 (.630")
Z	GH-Q-O-3649	10.5 - 10.9	12 (.472")	10.8 (.425")	20.0 (.787")	21.3 (.839")	112.3 (4.421")	13.5 (.531")	48 (1.890")	16 (.630")
	GH-Q-O-3653	11.0 - 11.4	14 (.551")	11.8 (.465")	24.0 (.945")	24.3 (.957")	119.8 (4.717")	14.2 (.559")	50 (1.969")	20 (.787")

COMBI Series Y, Z Chamfer Drill and Chamfer Blades

Series	Ød Drill* mm inches	Tool Holder ¹ Order #	Drill Tip Order #	Cmf. Series	Blade, Carbide-TiN, 90°, front and back** Order Number (Chamfer ØD mm)			
					(0.25mm x 45°) GH-Q-M-	(0.5mm x 45°) GH-Q-M-	(0.75mm x 45°) GH-Q-M-	Insert GH-H-P-
Y	9.53 .375	GH-Q-O-3641	P-A-Y-0953-2A	8	-03723 (10.0)	-03724 (10.5)	-03725 (11.0)	-0131
	10.0 .394	GH-Q-O-3641	P-A-Y-1000-2A		-03724 (10.5)	-03725 (11.0)	-03726 (11.5)	
	10.32 13/32"	GH-Q-O-3645	P-A-Y-1032-2A		-03725 (11.0)	-03726 (11.5)	-03727 (12.0)	
	10.5 .413	GH-Q-O-3645	P-A-Y-1050-2A		-03725 (11.0)	-03726 (11.5)	-03727 (12.0)	
Z	11.0 .433	GH-Q-O-3645	P-A-Y-1100-2A		-03726 (11.5)	-03727 (12.0)	-03728 (12.5)	
	11.1 7/16"	GH-Q-O-3649	P-A-Z-1110-2A		-03726 (11.5)	-03727 (12.0)	-03728 (12.5)	
	11.5 .453	GH-Q-O-3649	P-A-Z-1150-2A		-03727 (12.0)	-03728 (12.5)	-03729 (13.0)	
	11.91 15/32"	GH-Q-O-3649	P-A-Z-1191-2A		-03728 (12.5)	-03729 (13.0)	-03730 (13.5)	
	12.0 .472	GH-Q-O-3653	P-A-Z-1200-2A	-03740 (12.5)	-03741 (13.0)	-03742 (13.5)		
12.5 .492	GH-Q-O-3653	P-A-Z-1250-2A	12	-03741 (13.0)	-03742 (13.5)	-03743 (14.0)	-0128	
12.7 1/2"	GH-Q-O-3653	P-A-Z-1270-2A	-03742 (13.5)	-03743 (14.0)	-03744 (14.5)			

* Non-stock standard item with extended delivery time. Spade drill 10 piece minimum. Other drill sizes available upon request.

Example: Ød = 13.75mm (.541") - P-A-O-1375-2A.

** Chamfer blades are interchangeable; maximum chamfer diameter ØD = hole Ød + 1.5mm.

¹ Non-stock standard item with extended delivery time.

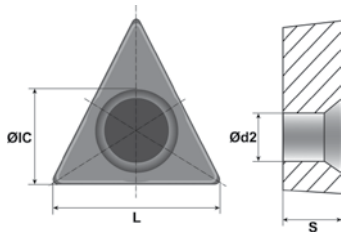

Indexable Inserts for Countersinking

Drill Ød	ØIC	L	S	Ød2	Order Number
9.5-11.9	3.97	6.8	1.59	2.2	GH-H-P-0140
12.0-14.9	5.56	9.6	2.38	2.5	GH-H-P-0128
15.0-19.9	6.35	11.0	2.38	2.8	GH-H-P-0130

SPARE PARTS PG. 127

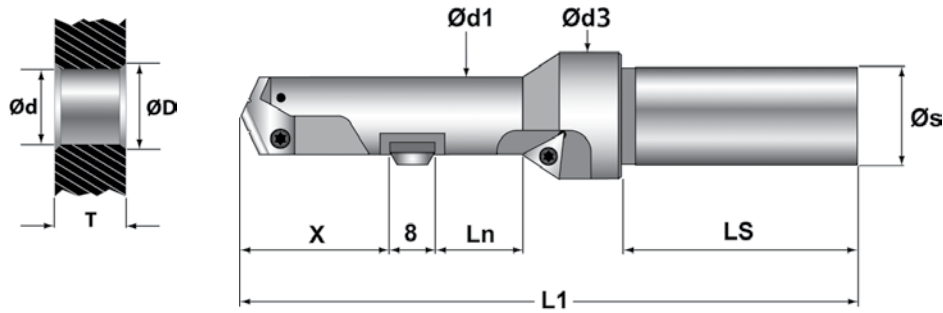

COMBI Drill Chamfer Tools Ø9.5-Ø17.9mm with Coolant Through

Series	Tool Holder Order Number	Ød Range mm	T	Ød1	Ød3	X	L1	Ln	Ls	Øs
0	GH-Q-0-3657S	11.5 - 11.9	16 (.630")	12.8 (.504")	24.0 (.945")	26.8 (1.055")	122.3 (4.815")	15.9 (.626")	50 (1.969")	20 (.787")
	GH-Q-0-3661S	12.0 - 12.4	18 (.709")	14.8 (.583")	26.0 (1.024")	29.8 (1.173")	125.3 (4.933")	18.4 (.724")	50 (1.969")	20 (.787")

COMBI Series 0 Chamfer Drill and Chamfer Blades

Series	Ød Drill* mm inches	Tool Holder ¹ Order #	Drill Tip Order #	Cmf. Series	Blade, Carbide-TiN, 90°, front and back** Order Number (Chamfer ØD mm)				Insert GH-H-P-
					(0.25mm x 45°) GH-Q-M-	(0.5mm x 45°) GH-Q-M-	(0.75mm x 45°) GH-Q-M-	(1.0mm x 45°) GH-Q-M-	
0	13.0 .511	GH-Q-0-3657S	P-A-0-1300-2A	12	-03742 (13.5)	-03743 (14.0)	-03744 (14.5)	-03745 (15.0)	-0128
	13.5 .531	GH-Q-0-3657S	P-A-0-1350-2A		-03743 (14.0)	-03744 (14.5)	-03745 (15.0)	-03746 (15.5)	
	14.0 .551	GH-Q-0-3657S	P-A-0-1400-2A		-03744 (14.5)	-03745 (15.0)	-03746 (15.5)	-03747 (16.0)	
	14.29 9/16"	GH-Q-0-3657S	P-A-0-1429-2A		-03745 (15.0)	-03746 (15.5)	-03747 (16.0)	-03748 (16.5)	
	14.5 .571	GH-Q-0-3657S	P-A-0-1450-2A		-03745 (15.0)	-03746 (15.5)	-03747 (16.0)	-03748 (16.5)	
	15.0 .591	GH-Q-0-3661S	P-A-0-1500-2A		-03746 (15.5)	-03747 (16.0)	-03748 (16.5)	-03749 (17.0)	
	15.5 .610	GH-Q-0-3661S	P-A-0-1550-2A		-03747 (16.0)	-03748 (16.5)	-03749 (17.0)	-03750 (17.5)	-0130
	15.88 5/8"	GH-Q-0-3661S	P-A-0-1588-2A		-03748 (16.5)	-03749 (17.0)	-03750 (17.5)	-03751 (18.0)	
	16.0 .630	GH-Q-0-3661S	P-A-0-1600-2A		-03748 (16.5)	-03749 (17.0)	-03750 (17.5)	-03751 (18.0)	
	16.5 .650	GH-Q-0-3661S	P-A-0-1650-2A		-03749 (17.0)	-03750 (17.5)	-03751 (18.0)	-03752 (18.5)	
	17.0 .669	GH-Q-0-3661S	P-A-0-1700-2A		-03750 (17.5)	-03751 (18.0)	-03752 (18.5)	-03753 (19.0)	
	17.46 11/16"	GH-Q-0-3661S	P-A-0-1746-2A		-03751 (18.0)	-03752 (18.5)	-03753 (19.0)	-03754 (19.5)	

* Non-stock standard item with extended delivery time. Spade drill 10 piece minimum. Other drill sizes available upon request.

Example: Ød = 13.75mm (.541") - P-A-0-1375-2A.

** Chamfer blades are interchangeable; maximum chamfer diameter ØD = hole Ød + 2mm.

¹ Non-stock standard item with extended delivery time.

HTC015

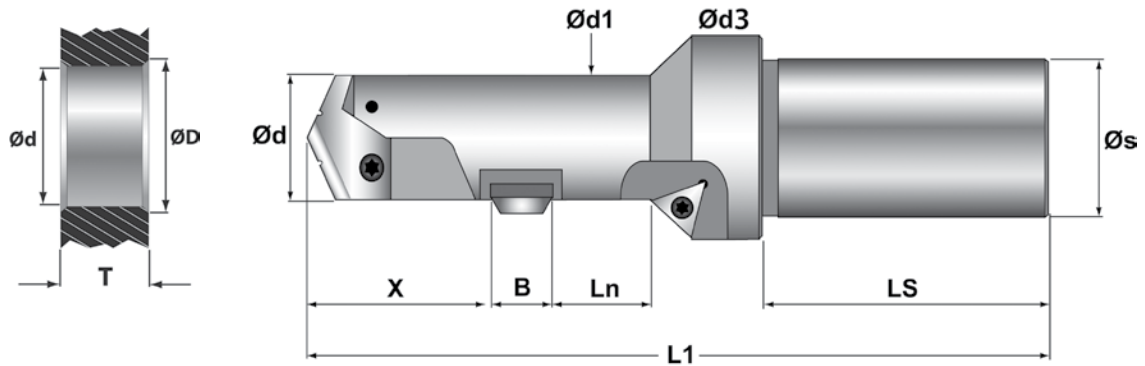

COMBI Drill Chamfer Tools Ø18.0-Ø35.0mm with Coolant Through

Series	Tool Holder Order Number	Ød Range mm	T	Ød1	B	Ød3	X	L1	Ln	Ls	Øs
1	GH-Q-0-3665S	13.0 - 14.9	20 (.787")	17.5 (.689")	8 (.315")	28.0 (.787")	34.6 (2.205")	125.6 (2.205")	22 (.866")	56 (2.205")	25 (.984")
	GH-Q-0-3669S	15.0 - 17.9	24 (.945")	19.8 (.780")	10 (.394")	30.0 (.787")	39.6 (2.205")	136.6 (2.205")	28 (1.102")	56 (2.205")	25 (.984")

COMBI Series 1 Chamfer Drill and Chamfer Blades

Series	Ød Drill* mm inches	Tool Holder ¹ Order #	Drill Tip Order #	Cmf. Series	Blade, Carbide-TiN, 90°, front and back** Order Number (Chamfer ØD mm)				Insert GH-H-P-
					(0.25mm x 45°) GH-Q-M-	(0.5mm x 45°) GH-Q-M-	(0.75mm x 45°) GH-Q-M-	(1.0mm x 45°) GH-Q-M-	
1	18.0 .709	GH-Q-0-3665S	P-A-1-1800-2A	12	-03752 (18.5)	-03753 (19.0)	-03754 (19.5)	-03755 (20.0)	-0130
	18.5 .728	GH-Q-0-3665S	P-A-1-1850-2A		-03753 (19.0)	-03754 (19.5)	-03755 (20.0)	-03756 (20.5)	
	19.05 3/4"	GH-Q-0-3665S	P-A-1-1905-2A		-03754 (19.5)	-03755 (20.0)	-03756 (20.5)	-03757 (21.0)	
	19.50 .768	GH-Q-0-3665S	P-A-1-1950-2A		-03755 (20.0)	-03756 (20.5)	-03757 (21.0)	-03758 (21.5)	
	20.0 .787	GH-Q-0-3669S	P-A-1-2000-2A	20	-	-03757 (21.0)	-03758 (21.5)	-03759 (22.0)	
	21.0 .827	GH-Q-0-3669S	P-A-1-2100-2A		-	-03770 (21.0)	-03771 (22.0)	-03772 (23.0)	
	22.0 .866	GH-Q-0-3669S	P-A-1-2200-2A		-	-03771 (22.0)	-03772 (23.0)	-03773 (24.0)	
	23.0 .906	GH-Q-0-3669S	P-A-1-2300-2A		-	-03772 (23.0)	-03773 (24.0)	-03774 (25.0)	
	24.0 .945	GH-Q-0-3669S	P-A-1-2400-2A		-	-03773 (24.0)	-03774 (25.0)	-03775 (26.0)	

* Non-stock standard item with extended delivery time. Spade drill 10 piece minimum. Other drill sizes available upon request.
Example: Ød = 26.5mm (1.043") - P-A-2-2650-2A.

** Chamfer blades are interchangeable; maximum chamfer diameter ØD = hole Ød + 2mm.

¹ Non-stock standard item with extended delivery time.

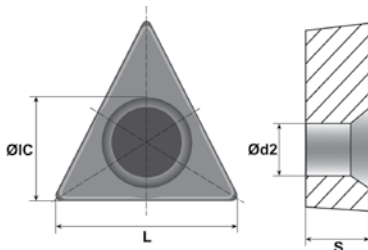

Indexable Inserts for Countersinking

Drill Ød	ØIC	L	S	Ød2	Order Number
15.0-35.0	6.35	11.0	2.38	2.8	GH-H-P-0130

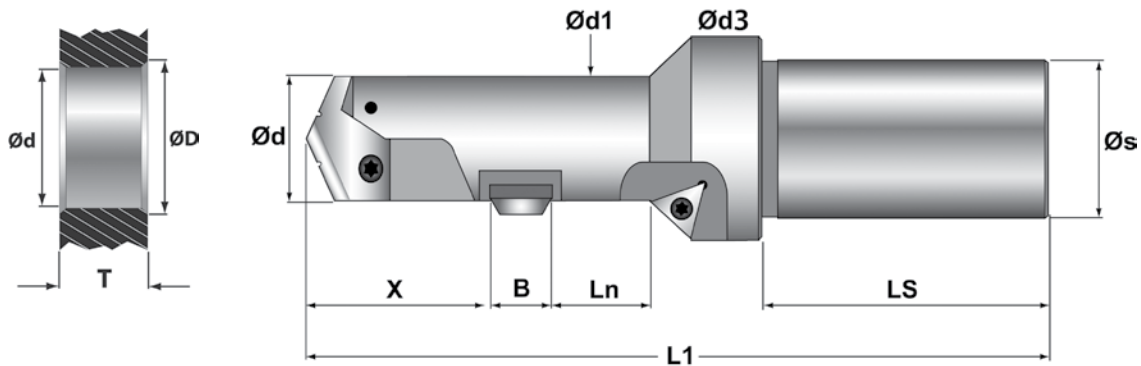

COMBI Drill Chamfer Tools Ø18.0-Ø35.0mm with Coolant Through

Series	Tool Holder Order Number	Ød Range mm	T	Ød1	B	Ød3	X	L1	Ln	Ls	Øs
2	GH-Q-0-3673S	25.0 - 29.9	30 (1.181")	24.2 (.953")	8 (.315")	38.0 (.787")	48.6 (2.262")	155.6 (2.262")	32 (1.260")	60 (2.262")	32 (1.260")
	GH-Q-0-3677S	30.0 - 34.9	38 (1.496")	29.8 (1.173")	10 (.394")	42.0 (.945")	59.6 (2.262")	171.6 (2.262")	40 (1.575")	60 (2.262")	32 (1.260")

COMBI Series 2 Chamfer Drill and Chamfer Blades

Series	Ød Drill* mm inches	Tool Holder ¹ Order #	Drill Tip Order #	Cmf. Series	Blade, Carbide-TiN, 90°, front and back** Order Number (Chamfer ØD mm)			Insert GH-H-P-
					(0.5mm x 45°) GH-Q-M-	(0.75mm x 45°) GH-Q-M-	(1.0mm x 45°) GH-Q-M-	
2	25.0 .984	GH-Q-0-3673S	P-A-2-2500-2A	20	-03775 (26.0)	-03776 (27.0)	-03777 (28.0)	-0130
	25.4 1.00	GH-Q-0-3673S	P-A-2-2540-2A		-03775 (26.0)	-03776 (27.0)	-03777 (28.0)	
	26.0 1.023	GH-Q-0-3673S	P-A-2-2600-2A		-03776 (27.0)	-03777 (28.0)	-03778 (29.0)	
	27.0 1.063	GH-Q-0-3673S	P-A-2-2700-2A		-03777 (28.0)	-03778 (29.0)	-03779 (30.0)	
	28.0 1.102	GH-Q-0-3673S	P-A-2-2800-2A		-03778 (29.0)	-03779 (30.0)	-03780 (31.0)	
	29.0 1.141	GH-Q-0-3673S	P-A-2-2900-2A		-03779 (30.0)	-03780 (31.0)	-03781 (32.0)	
	30.0 1.181	GH-Q-0-3677S	P-A-2-3000-2A		-03780 (31.0)	-03781 (32.0)	-03782 (33.0)	
	31.0 1.220	GH-Q-0-3677S	P-A-2-3100-2A		-03780 (31.0)	-03781 (32.0)	-03782 (33.0)	
	31.75 1 1/4"	GH-Q-0-3677S	P-A-2-3175-2A		-03781 (32.0)	-03782 (33.0)	-03783 (34.0)	
	32.0 1.260	GH-Q-0-3677S	P-A-2-3200-2A		-03782 (33.0)	-03783 (34.0)	-03784 (35.0)	
	33.0 1.300	GH-Q-0-3677S	P-A-2-3300-2A		-03783 (34.0)	-03784 (35.0)	-03785 (36.0)	
	34.0 1.339	GH-Q-0-3677S	P-A-2-3400-2A		-03784 (35.0)	-03785 (36.0)	-03786 (37.0)	
	35.0 1.378	GH-Q-0-3677S	P-A-2-3500-2A		-03785 (36.0)	-03786 (37.0)	-03787 (38.0)	

* Non-stock standard item with extended delivery time. Spade drill 10 piece minimum. Other drill sizes available upon request.

Example: Ød = 26.5mm (1.043") - P-A-2-2650-2A.

** Chamfer blades are interchangeable; maximum chamfer diameter ØD = hole Ød + 2mm.

¹ Non-stock standard item with extended delivery time.

Feed and Speed Information-Carbide Drill Blade

	Brinell	Carbide Grade	Feed (IPR) Bore Size, Ød				
			Ft/min	9.5-12.5	13-17	18-24	25-35
Free Machining Steel	100-150	C5	320	.006	.009	.012	.015
	150-200		280	.006	.008	.011	.013
	200-250		260	.005	.008	.010	.012
Low Carbon Steel	85-125	HSS/C5	300	.006	.008	.010	.014
	125-175		260	.005	.008	.010	.014
	175-225		240	.004	.007	.008	.012
Medium Carbon Steel	125-175	HSS/C5	260	.005	.008	.010	.014
	175-225		240	.005	.007	.008	.012
	225-275		220	.004	.007	.008	.012
Alloy Steel	125-175	C5	250	.005	.008	.010	.013
	175-225		230	.005	.007	.009	.012
	225-275		210	.004	.007	.009	.012
High Strength Alloy	225-300	C5	160	.005	.007	.008	.010
	300-350		140	.004	.006	.007	.009
Structural Steel	100-150	C5	240	.006	.010	.011	.012
	150-250		200	.005	.008	.009	.011
High Temp Alloy	140-220	C2	80	.003	.006	.007	.009
	220-310		60	.003	.005	.006	.008
Stainless Steel	135-185	C2	160	.006	.008	.009	.011
	185-275		120	.005	.007	.008	.010
Tool Steel	150-200	C5	160	.003	.005	.007	.009
	200-250		120	.003	.005	.007	.009
Aluminum	30	C2	1200	.008	.013	.016	.020
	180		800	.007	.011	.014	.018
Cast Iron	120-150	C2	320	.006	.009	.011	.015
	150-200		270	.005	.008	.010	.014
	200-220		240	.005	.007	.008	.012

SNAP Chamfer Inserts

Material	IPR (SNAP - GS)	SFM
Aluminum	0.006-0.012	320-800
Brass	0.006-0.014	210-400
Low Carbon Steels	0.004-0.008	150-210
Med Carbon Steels	0.004-0.009	130-180
Free Machining Alloys	0.004-0.006	100-160
Stainless Steel	0.002-0.005	90-140
Gray Cast Iron	0.004-0.008	150-220
Nodular Cast Iron	0.003-0.007	150-220
Short Chipping Iron	0.003-0.007	100-150
Titanium	0.001-0.003	20-50

Important: Tool holder must be modified with blade locking mechanism for spindle speeds above 6,000 rpm. Please contact Heule Tool Corporation Engineering Department.

Programming Instructions - Drill Chamfer Tool

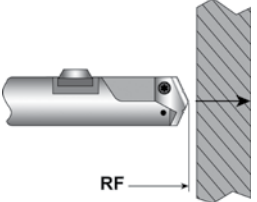
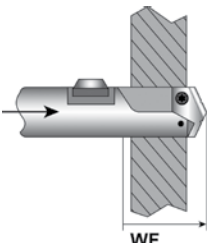
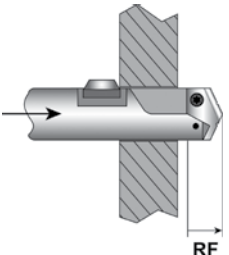
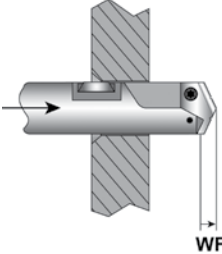
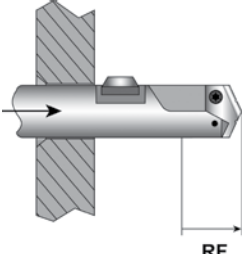
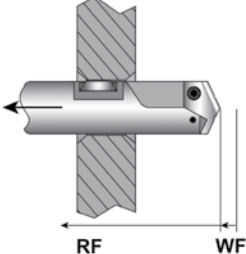
	<p>Step 1: Rapid Feed the tool to within clearance of the workpiece.</p>
	<p>Step 2: With forward Working Feed (WF), feed the tool through the workpiece until the hole is drilled and the drill tip is clear of the bore.</p>
	<p>Step 3: Rapid feed the tool so the SNAP blade is within clearance of the workpiece top surface or burr.</p>
	<p>Step 4: With working feed, cut the top chamfer. Continue feeding until the SNAP blade is completely retracted into the tool body.</p>
	<p>Step 5: Use rapid feed to position the SNAP blade on the far side of the part. Position the tool so the SNAP blade is completely extended and clear of the part or burr.</p>
	<p>Step 6: With back working feed, cut the back chamfer. When the SNAP blade is completely within the tool and clear of the back surface, the tool can be extracted with rapid feed.</p>

Programming Instructions - Drill Countersink Chamfer Tool

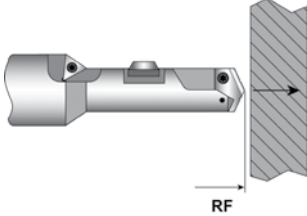
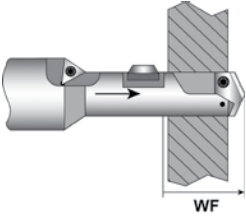
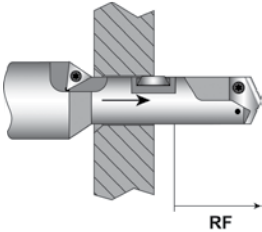
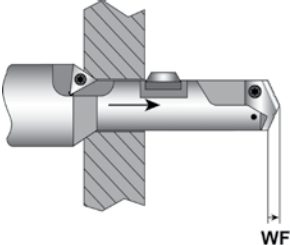
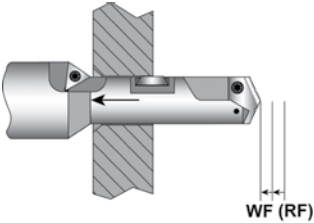
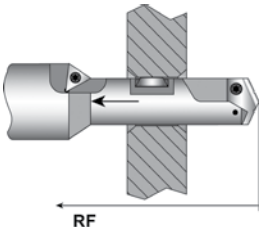
	<p>Step 1: Rapid Feed the tool to within clearance of the workpiece.</p>
	<p>Step 2: With forward Working Feed (WF), feed the tool through the workpiece until the hole is drilled and the drill tip is clear of the bore.</p>
	<p>Step 3: Rapid feed the tool so the SNAP blade is within clearance of the workpiece top surface or burr.</p>
	<p>Step 4: With working feed, cut the top countersink. Continue feeding until the required countersink size is achieved.</p>
	<p>Step 5: If necessary, use rapid backward feed to position the SNAP insert within clearance distance of the back surface of the workpiece or burr. The back chamfer can then be cut in working backward feed.</p>
	<p>Step 6: When the SNAP insert is clear of the back surface and completely retracted in the tool body, the tool can be retracted from the workpiece using rapid backward feed.</p>

COMBI Drill Chamfer Tools

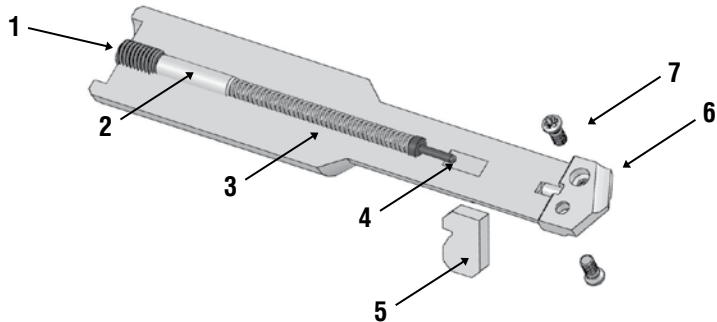

COMBI Drill/Countersink/Chamfer Tools

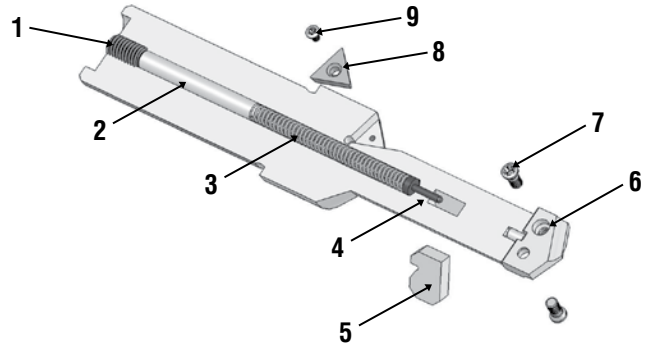

COMBI Drill Chamfer Tools Ø9.5-Ø17.99mm-Spare Parts

Series	Tool Holder	1	2	3	4	5 and 6	7	Size
		Set Screw	Distance Pin	Spring	Control Bolt	Chamfer & Drill Blades	Torx Screw	
Y	GH-Q-O-3441	GH-H-S-0119	GH-Q-E-0021	GH-H-F-0007	GH-Q-E-0002	See Page 116	GH-H-S-0070	IP7
	GH-Q-O-3445	GH-H-S-0119	GH-Q-E-0021	GH-H-F-0007	GH-Q-E-0002	See Page 116	GH-H-S-0070	IP7
Z	GH-Q-O-3449	GH-H-S-0119	GH-Q-E-0021	GH-H-F-0007	GH-Q-E-0002	See Page 116	GH-H-S-0071	IP7
	GH-Q-O-3453	GH-H-S-0119	GH-Q-E-0021	GH-H-F-0007	GH-Q-E-0002	See Page 116	GH-H-S-0071	IP7
0	GH-Q-O-3457	GH-H-S-0119	GH-Q-E-0021	GH-H-F-0007	GH-Q-E-0002	See Page 117	GH-H-S-0066	T8
	GH-Q-O-3461	GH-H-S-0119	GH-Q-E-0022	GH-H-F-0007	GH-Q-E-0002	See Page 117	GH-H-S-0067	IP8

COMBI Drill Chamfer Tools Ø18.0-Ø35.0mm-Spare Parts

Series	Tool Holder	1	2	3	4	5 and 6	7	Size
		Set Screw	Distance Pin	Spring	Control Bolt	Chamfer & Drill Blades	Torx Screw	
1	GH-Q-O-3465	GH-H-S-0119	GH-Q-E-0023	GH-H-F-0007	GH-Q-E-0002	See Page 118	GH-H-S-0068	IP9
	GH-Q-O-3469	GH-H-S-0119	GH-Q-E-0023	GH-H-F-0011	GH-Q-E-0003	See Page 118	GH-H-S-0069	IP9
2	GH-Q-O-3473	GH-H-S-0119	GH-Q-E-0025	GH-H-F-0011	GH-Q-E-0003	See Page 119	GH-H-S-0072	IP15
	GH-Q-O-3477	GH-H-S-0119	GH-Q-E-0026	GH-H-F-0011	GH-Q-E-0003	See Page 119	GH-H-S-0072	IP15

COMBI Drill/Countersink/Chamfer Tools Ø9.5-Ø17.99mm-Spare Parts

Series	Tool Holder	1	2	3	4	5 and 6	7	8	9	Size
		Set Screw	Distance Pin	Spring	Control Bolt	Chamfer & Drill Blades	Torx Screw*	C'sink Insert	Torx Screw	
Y	GH-Q-O-3641	GH-H-S-0119	GH-Q-E-0023	GH-H-F-0007	GH-Q-E-0002	See Page 120	GH-H-S-0070	GH-H-P-0131	GH-H-S-0055	T6
	GH-Q-O-3645	GH-H-S-0119	GH-Q-E-0023	GH-H-F-0007	GH-Q-E-0002	See Page 120	GH-H-S-0070	GH-H-P-0131	GH-H-S-0055	T6
Z	GH-Q-O-3649	GH-H-S-0119	GH-Q-E-0023	GH-H-F-0007	GH-Q-E-0002	See Page 120	GH-H-S-0071	GH-H-P-0131	GH-H-S-0055	T6
	GH-Q-O-3653	GH-H-S-0119	GH-Q-E-0024	GH-H-F-0007	GH-Q-E-0002	See Page 120	GH-H-S-0071	GH-H-P-0128	GH-H-S-0050	T6
0	GH-Q-O-3657	GH-H-S-0119	GH-Q-E-0024	GH-H-F-0007	GH-Q-E-0002	See Page 121	GH-H-S-0066	GH-H-P-0128	GH-H-S-0050	T6
	GH-Q-O-3661	GH-H-S-0119	GH-Q-E-0024	GH-H-F-0007	GH-Q-E-0002	See Page 121	GH-H-S-0067	GH-H-P-0130	GH-H-S-0051	T7

COMBI Drill/Countersink/Chamfer Tools Ø18.0-Ø35.0mm-Spare Parts

Series	Tool Holder	1	2	3	4	5 and 6	7	8	9	Size
		Set Screw	Distance Pin	Spring	Control Bolt	Chamfer & Drill Blades	Torx Screw*	C'sink Insert	Torx Screw	
1	GH-Q-O-3665	GH-H-S-0119	GH-Q-E-0026	GH-H-F-0007	GH-Q-E-0002	See Page 122	GH-H-S-0068	GH-H-P-0130	GH-H-S-0051	T7
	GH-Q-O-3669	GH-H-S-0119	GH-Q-E-0026	GH-H-F-0011	GH-Q-E-0003	See Page 122	GH-H-S-0069	GH-H-P-0130	GH-H-S-0051	T7
2	GH-Q-O-3673	GH-H-S-0119	GH-Q-E-0029	GH-H-F-0011	GH-Q-E-0003	See Page 123	GH-H-S-0072	GH-H-P-0130	GH-H-S-0051	T7
	GH-Q-O-3677	GH-H-S-0119	GH-Q-E-0030	GH-H-F-0011	GH-Q-E-0003	See Page 123	GH-H-S-0072	GH-H-P-0130	GH-H-S-0051	T7

*Torx Screw	GH-H-S-	0070/0071	0066	0067	0068/0069	0072
Size		IP7	T8	IP8	IP9	IP15



Visit our website for our full line
of product brochures and videos

www.HeuleTool.com

We provide online tool selectors for the
COFA, **SNAP**, **DEFA** and **BSF** product groups.

Simply enter your application information and the correct tool will
be provided complete with order number and sample drawing.

We are also available on:



DEFA

Precision Chamfering for the Front and Back of Through Holes

- Chamfers front and back in a single pass
- Adjustable chamfer range to provide precise chamfer size
- Solid carbide cutting blades with coatings to provide long tool life
- Sliding surface in blade geometry prevents damage to finished holes

The HEULE DEFA chamfering tool was designed to offer controlled chamfers over a range of adjustments. DEFA chamfers the front and back of through holes without reversing the spindle or indexing the work piece. The DEFA tool offers the user a high quality chamfering tool with TiN coated solid carbide cutting blades.

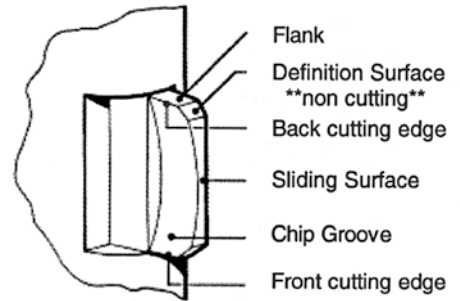

Consistent Chamfers

One of the biggest advantages of the DEFA tool is the ability to set the chamfer size. The DEFA tool is designed to allow the user to set the blade force, which holds the blades to the desired size and allows the blades to cut consistent chamfers despite material or burr size. This provides precise front and back chamfers specific to the user's needs.

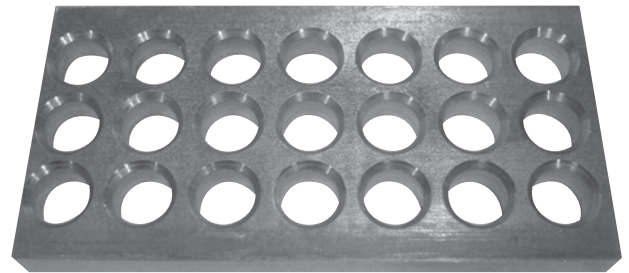

Protects Threaded Holes

The DEFA blade geometry has a sliding surface that allows the tool to cut chamfers without damaging the bore or thread surface. This provides a finished hole once the chamfers are cut.

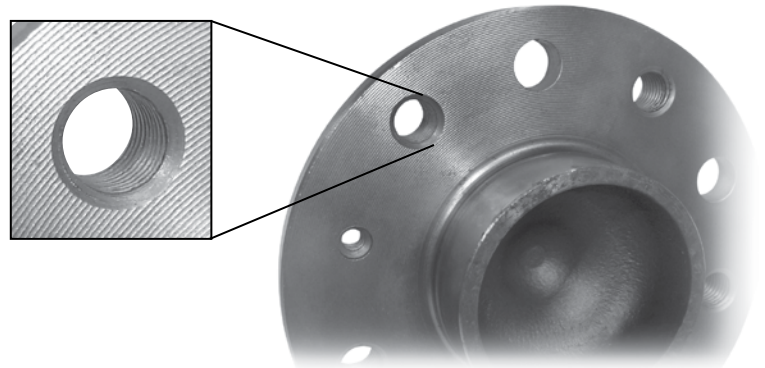

Ideal for the Aerospace Industry

Starting at 4mm, the DEFA tool offers consistent chamfers ideal for cutting Inconel and other exotic materials. The spring loaded tool with form cutting blades reacts only when both cutting blades touch the part. Tooling is available with front and back cutting or back cutting only geometry.



How Does It Work?

The DEFA tool cuts a pre-adjusted chamfer diameter. The blade force keeps the DEFA blades out to the predetermined setting, thereby defining the chamfer diameter. The blade's upper and lower cutting edge permit machining in both forward and reverse directions.

As the DEFA blades enter the material, the force occurring through the feed on to the chamfer definition surface causes the blades to retract radially along the axis of the chamfered surface. The cutting width is constantly reduced. The definition surface angle determines the chamfer angle.

Damage to the hole or thread surface is prevented by the sliding surface geometry of the DEFA blades.

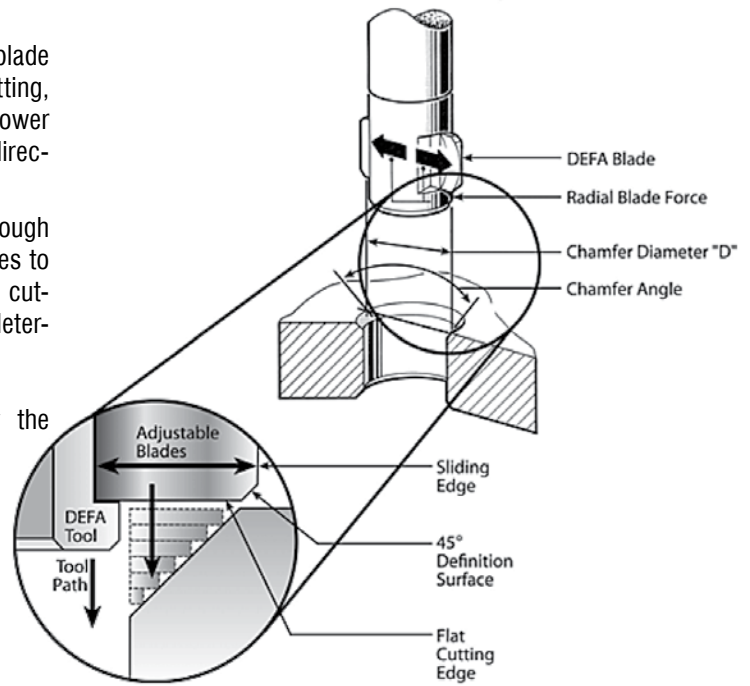

Typical Parts

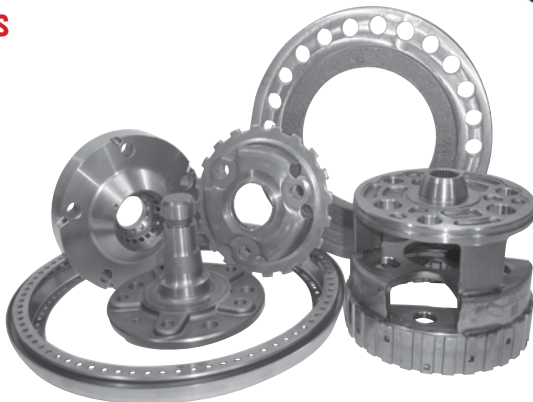

How to Order:

To select the correct tool you must know the hole size and chamfer size required. Cutting blade options also include front & back cutting and back only cutting.

Use the minimum hole column to choose the tool holder best matching your drill hole size. Check to make sure the chamfer diameter requirement does not exceed the maximum chamfer. Calculate the ØD2 (over the blade) diameter and add this dimension as a suffix to the order number. See page 150- for information on how to calculate ØD2.

Add "p" to the order number if you need the tool with an End Plug. Leave blank for tool with straight shank.

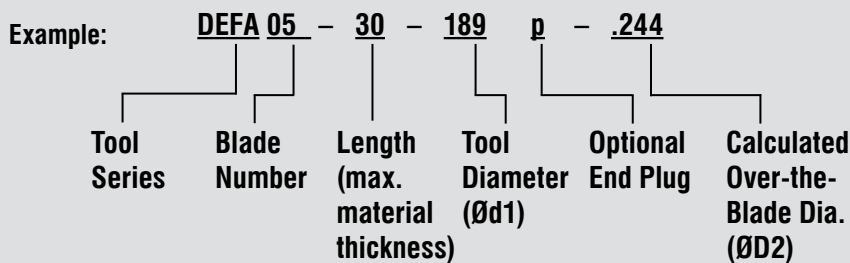

HTC015

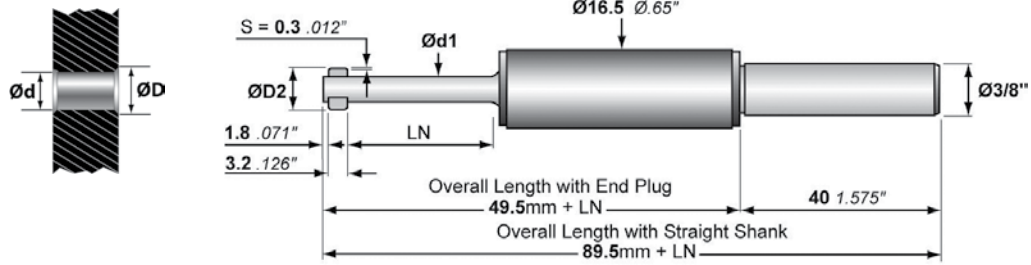

DEFA Series 02-06

Ød1 = Ødmin – .2mm (.008")

Min. Hole Ød	Max Chamfer ØD	Max ØD2	Tool Holder without blades			TiAIN Blade Set	
			Order Number Short	Order Number Standard	Order Number Long	Order Number	Order Number
mm inches	mm inches	mm inches	LN = 15mm	LN = 30mm	LN = 60mm	Front/Back	Back only
4.0 .157	4.8 .189	5.4 .213	DEFA02-15-150- □/___	DEFA02-30-150- □/___	DEFA02-60-150-□/___	-3X02	-4X02
4.1 .161			DEFA02-15-153- □/___	DEFA02-30-153- □/___	DEFA02-60-153-□/___		
4.2 .165			DEFA02-15-157- □/___	DEFA02-30-157- □/___	DEFA02-60-157-□/___		
4.3 .169	5.2 .205	5.8 .229	DEFA03-15-161- □/___	DEFA03-30-161- □/___	DEFA03-60-161-□/___	-3X03	-4X03
4.4 .173			DEFA03-15-165- □/___	DEFA03-30-165- □/___	DEFA03-60-165-□/___		
4.5 .177			DEFA03-15-169- □/___	DEFA03-30-169- □/___	DEFA03-60-169-□/___		
4.6 .181	5.8 .228	6.4 .252	DEFA04-15-173- □/___	DEFA04-30-173- □/___	DEFA04-60-173-□/___	-3X04	-4X04
4.7 .185			DEFA04-15-177- □/___	DEFA04-30-177- □/___	DEFA04-60-177-□/___		
4.8 .189			DEFA04-15-181- □/___	DEFA04-30-181- □/___	DEFA04-60-181-□/___		
4.9 .193	6.4 .252	+ '\$.276	DEFA05-15-189- □/___	DEFA05-30-189- □/___	DEFA05-60-189-□/___	-3X05	-4X05
5.0 .197			DEFA05-15-193- □/___	DEFA05-30-193- □/___	DEFA05-60-193-□/___		
5.1 .201			DEFA05-15-197- □/___	DEFA05-30-197- □/___	DEFA05-60-197-□/___		
5.2 .205	6.8 .268	7.4 .292	DEFA05-15-201- □/___	DEFA05-30-201- □/___	DEFA05-60-201-□/___	-3X06	-4X06
5.3 .209			DEFA05-15-205- □/___	DEFA05-30-205- □/___	DEFA05-60-205-□/___		
5.4 .213			DEFA06-15-209- □/___	DEFA06-30-209- □/___	DEFA06-60-209-□/___		
5.5 .216	6.8 .268	7.4 .292	DEFA06-15-213- □/___	DEFA06-30-213- □/___	DEFA06-60-213-□/___	-3X06	-4X06
5.6 .220			DEFA06-15-216- □/___	DEFA06-30-216- □/___	DEFA06-60-216-□/___		
5.7 .224			DEFA06-15-220- □/___	DEFA06-30-220- □/___	DEFA06-60-220-□/___		
5.8 .228	6.8 .268	7.4 .292	DEFA06-15-224- □/___	DEFA06-30-224- □/___	DEFA06-60-224-□/___	-3X06	-4X06
5.9 .232			DEFA06-15-224- □/___	DEFA06-30-224- □/___	DEFA06-60-224-□/___		

To order the tool with a pre-set chamfer size, we recommend adding a calculated over-the-blade diameter ($\text{ØD2} = \text{ØD} + .024"$) as a suffix to the order number, otherwise a calculated default dimension is used ($\text{ØD2} = .052" + \text{Ød1}$).

The first tool in each series are STANDARD TOOLS which should be used when you have a stable set-up and are cutting any material under 28 Rc.

□ – Add “p” for tool with end plug.
Leave blank for tool with straight shank.
___ – Fill in your calculated over-the-blade diameter
 $\text{ØD2} = \text{ØD} + .024"$ or $\text{ØD2} = \text{ØD} + (2x's)$

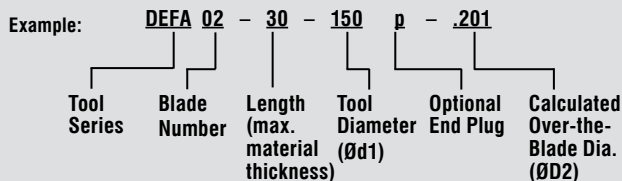

BLADE
OPTIONS **PG. 149**

SPARE
PARTS **PG. 133**

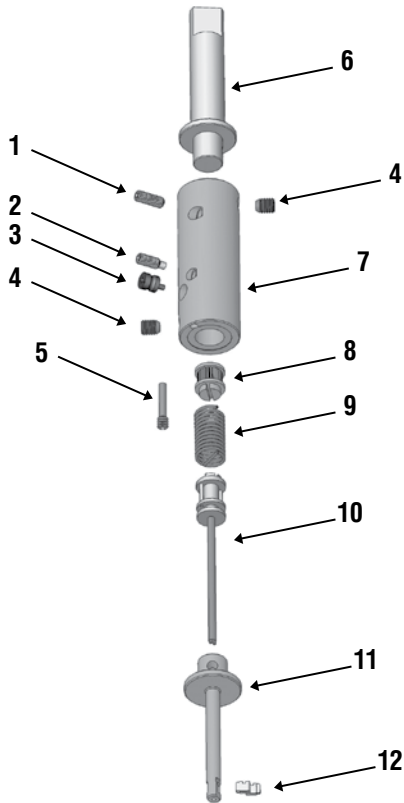

Spare Parts – DEFA Series 02-06

	Order Number	Description
1	GH-H-S-0101	Tension Screw
2	GH-H-S-0322	Set Screw
3	GH-S-E-0001	Eccentric Cam
4	GH-H-S-0201	Clamping Screw
5	GH-S-X-0001	Positioning Screw
6	GH-S-S-0155**	3/8" Straight Shank
	GH-S-S-0090**	End Plug
7	GH-S-G-0001	Tool Body
8	GH-S-C-0001	Gear Wheel
9	GH-S-T-0001	Torsion Spring
10	GH-S-W-0002	Blade Control-Length=15mm
	GH-S-W-0003	Blade Control-Length=30mm
	GH-S-W-0027*	Blade Control-Length=60mm
11	Blade Housing	See housing chart below
12	Blade Set	See table on pg. 132

*Non-stock standard item with extended delivery time.

**Tool bodies are sold with either a straight shank or end plug, please read the ordering instructions to indicate your preference. Other options are available and sold separately. Please contact engineering for details.

DEFA Series 02-06 – Blade Housing Chart*

Tool Holder Order Number	Blade Housing Order Number	Tool Holder Order Number	Blade Housing Order Number	Tool Holder Order Number	Blade Housing Order Number
DEFA02-15-150	GH-S-N-1000	DEFA02-30-150	GH-S-N-1001	DEFA02-60-150	GH-S-N-1002
DEFA02-15-153	GH-S-N-1003	DEFA02-30-153	GH-S-N-1004	DEFA02-60-153	GH-S-N-1005
DEFA02-15-157	GH-S-N-1006	DEFA02-30-157	GH-S-N-1007	DEFA02-60-157	GH-S-N-1008
DEFA03-15-161	GH-S-N-1009	DEFA03-30-161	GH-S-N-1010	DEFA03-60-161	GH-S-N-1011
DEFA03-15-165	GH-S-N-1012	DEFA03-30-165	GH-S-N-1013	DEFA03-60-165	GH-S-N-1014
DEFA03-15-169	GH-S-N-1015	DEFA03-30-169	GH-S-N-1016	DEFA03-60-169	GH-S-N-1017
DEFA04-15-173	GH-S-N-1018	DEFA04-30-173	GH-S-N-1019	DEFA04-60-173	GH-S-N-1020
DEFA04-15-177	GH-S-N-1021	DEFA04-30-177	GH-S-N-1022	DEFA04-60-177	GH-S-N-1023
DEFA04-15-181	GH-S-N-1024	DEFA04-30-181	GH-S-N-1025	DEFA04-60-181	GH-S-N-1026
DEFA04-15-185	GH-S-N-1027	DEFA04-30-185	GH-S-N-1028	DEFA04-60-185	GH-S-N-1029
DEFA05-15-189	GH-S-N-1030	DEFA05-30-189	GH-S-N-1031	DEFA05-60-189	GH-S-N-1032
DEFA05-15-193	GH-S-N-1033	DEFA05-30-193	GH-S-N-1034	DEFA05-60-193	GH-S-N-1035
DEFA05-15-197	GH-S-N-1036	DEFA05-30-197	GH-S-N-1037	DEFA05-60-197	GH-S-N-1038
DEFA05-15-201	GH-S-N-1039	DEFA05-30-201	GH-S-N-1040	DEFA05-60-201	GH-S-N-1041
DEFA05-15-205	GH-S-N-1042	DEFA05-30-205	GH-S-N-1043	DEFA05-60-205	GH-S-N-1044
DEFA06-15-209	GH-S-N-1045	DEFA06-30-209	GH-S-N-1046	DEFA06-60-209	GH-S-N-1047
DEFA06-15-213	GH-S-N-1048	DEFA06-30-213	GH-S-N-1049	DEFA06-60-213	GH-S-N-1050
DEFA06-15-216	GH-S-N-1051	DEFA06-30-216	GH-S-N-1052	DEFA06-60-216	GH-S-N-1053
DEFA06-15-220	GH-S-N-1054	DEFA06-30-220	GH-S-N-1055	DEFA06-60-220	GH-S-N-1056
DEFA06-15-224	GH-S-N-1057	DEFA06-30-224	GH-S-N-1058	DEFA06-60-224	GH-S-N-1059

*Extended delivery time

PROGRAMMING PG. 151-152

CHANGE BLADES PG. 153

HTC015

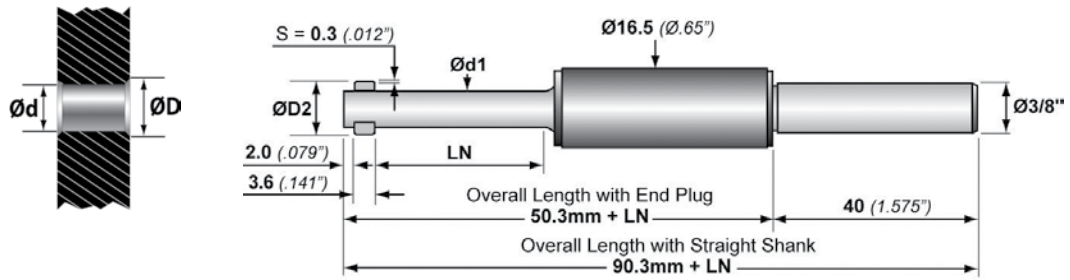

DEFA Series 07-09

Ød1 = Ødmin – .2mm (.008")

Min. Hole Ød	Max Chamfer ØD	Max ØD2	Tool Holder without blades			TiAlN Blade Set	
			Order Number Short	Order Number Standard	Order Number Long	Order Number	
mm inches	mm inches	mm inches	LN = 20mm	LN = 34mm	LN = 60mm	Front/Back	Back only
6.0 .236	6.8 .268	7.4 .292	DEFA07-20-228-□/___	DEFA07-34-228-□/___	DEFA07-60-228-□/___	-3X07	-4X07
6.1 .240			DEFA07-20-232-□/___	DEFA07-34-232-□/___	DEFA07-60-232-□/___		
6.2 .244			DEFA07-20-236-□/___	DEFA07-34-236-□/___	DEFA07-60-236-□/___		
6.3 .248	7.6 .299	8.2 .323	DEFA08-20-240-□/___	DEFA08-34-240-□/___	DEFA08-60-240-□/___	-3X08	-4X08
6.4 .252			DEFA08-20-244-□/___	DEFA08-34-244-□/___	DEFA08-60-244-□/___		
6.5 .256			DEFA08-20-248-□/___	DEFA08-34-248-□/___	DEFA08-60-248-□/___		
6.6 .260			DEFA08-20-252-□/___	DEFA08-34-252-□/___	DEFA08-60-252-□/___		
6.7 .264			DEFA08-20-256-□/___	DEFA08-34-256-□/___	DEFA08-60-256-□/___		
6.8 .268	8.5 .335	9.1 .359	DEFA09-20-260-□/___	DEFA09-34-260-□/___	DEFA09-60-260-□/___	-3X09	-4X09
6.9 .272			DEFA09-20-264-□/___	DEFA09-34-264-□/___	DEFA09-60-264-□/___		
7.0 .276			DEFA09-20-268-□/___	DEFA09-34-268-□/___	DEFA09-60-268-□/___		
7.1 .280			DEFA09-20-272-□/___	DEFA09-34-272-□/___	DEFA09-60-272-□/___		
7.2 .283			DEFA09-20-276-□/___	DEFA09-34-276-□/___	DEFA09-60-276-□/___		
7.3 .287			DEFA09-20-280-□/___	DEFA09-34-280-□/___	DEFA09-60-280-□/___		
7.4 .291			DEFA09-20-283-□/___	DEFA09-34-283-□/___	DEFA09-60-283-□/___		
7.5 .295			DEFA09-20-287-□/___	DEFA09-34-287-□/___	DEFA09-60-287-□/___		
7.6 .299			DEFA09-20-291-□/___	DEFA09-34-291-□/___	DEFA09-60-291-□/___		

To order the tool with a pre-set chamfer size, we recommend adding a calculated over-the-blade diameter (ØD2 = ØD + .024") as a suffix to the order number, otherwise a calculated default dimension is used (ØD2 = .052" + Ød1).

The first tool in each series are STANDARD TOOLS which should be used when you have a stable set-up and are cutting any material under 28 Rc.

□ – Add "p" for tool with end plug.
Leave blank for tool with straight shank.
___ – Fill in your calculated over-the-blade diameter
ØD2 = ØD + .024" or **ØD2 = ØD + (2x's')**

Example: **DEFA 07 - 34 - 228 p - .280**

Tool Series	Blade Number	Length (max. material thickness)	Tool Diameter (Ød1)	Optional End Plug	Calculated Over-the-Blade Dia. (ØD2)
-------------	--------------	----------------------------------	---------------------	-------------------	--------------------------------------

BLADE
OPTIONS **PG. 149**

SPARE
PARTS **PG. 135**

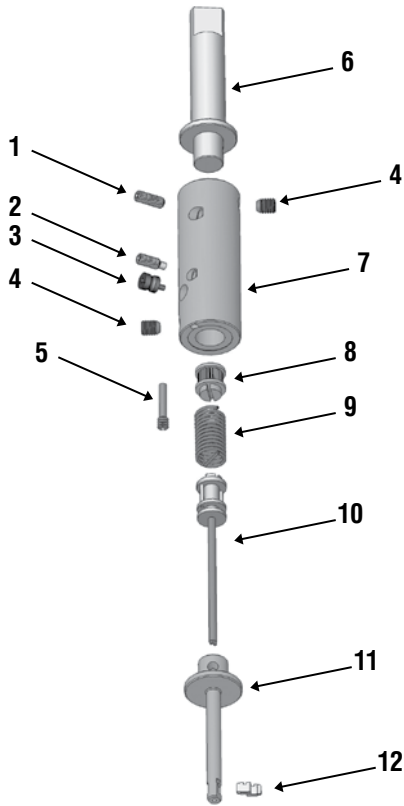

Spare Parts – DEFA Series 07-09

	Order Number	Description
1	GH-H-S-0101	Tension Screw
2	GH-H-S-0322	Set Screw
3	GH-S-E-0001	Eccentric Cam
4	GH-H-S-0201	Clamping Screw
5	GH-S-X-0001	Positioning Screw
6	GH-S-S-0155**	3/8" Straight Shank
	GH-S-S-0090**	End Plug
7	GH-S-G-0001	Tool Body
8	GH-S-C-0001	Gear Wheel
9	GH-S-T-0001	Torsion Spring
10	GH-S-W-0604	Blade Control-Length=20mm
	GH-S-W-0605	Blade Control-Length=34mm
	GH-S-W-0628*	Blade Control-Length=60mm
11	Blade Housing	See housing chart below
12	Blade Set	See table on pg. 134

*Non-stock standard item with extended delivery time.

**Tool bodies are sold with either a straight shank or end plug, please read the ordering instructions to indicate your preference. Other options are available and sold separately. Please contact engineering for details.

DEFA Series 07-09 – Blade Housing Chart*

Tool Holder Order Number	Blade Housing Order Number	Tool Holder Order Number	Blade Housing Order Number	Tool Holder Order Number	Blade Housing Order Number
DEFA07-20-228	GH-S-N-1081	DEFA07-34-228	GH-S-N-1082	DEFA07-60-228	GH-S-N-1083
DEFA07-20-232	GH-S-N-1084	DEFA07-34-232	GH-S-N-1085	DEFA07-60-232	GH-S-N-1086
DEFA07-20-236	GH-S-N-1087	DEFA07-34-236	GH-S-N-1088	DEFA07-60-236	GH-S-N-1089
DEFA08-20-240	GH-S-N-1090	DEFA08-34-240	GH-S-N-1091	DEFA08-60-240	GH-S-N-1092
DEFA08-20-244	GH-S-N-1093	DEFA08-34-244	GH-S-N-1094	DEFA08-60-244	GH-S-N-1095
DEFA08-20-248	GH-S-N-1096	DEFA08-34-248	GH-S-N-1097	DEFA08-60-248	GH-S-N-1098
DEFA08-20-252	GH-S-N-1099	DEFA08-34-252	GH-S-N-1100	DEFA08-60-252	GH-S-N-1101
DEFA08-20-256	GH-S-N-1102	DEFA08-34-256	GH-S-N-1103	DEFA08-60-256	GH-S-N-1104
DEFA09-20-260	GH-S-N-1105	DEFA09-34-260	GH-S-N-1106	DEFA09-60-260	GH-S-N-1107
DEFA09-20-264	GH-S-N-1108	DEFA09-34-264	GH-S-N-1109	DEFA09-60-264	GH-S-N-1110
DEFA09-20-268	GH-S-N-1111	DEFA09-34-268	GH-S-N-1112	DEFA09-60-268	GH-S-N-1113
DEFA09-20-272	GH-S-N-1114	DEFA09-34-272	GH-S-N-1115	DEFA09-60-272	GH-S-N-1116
DEFA09-20-276	GH-S-N-1117	DEFA09-34-276	GH-S-N-1118	DEFA09-60-276	GH-S-N-1119
DEFA09-20-280	GH-S-N-1120	DEFA09-34-280	GH-S-N-1121	DEFA09-60-280	GH-S-N-1122
DEFA09-20-283	GH-S-N-1123	DEFA09-34-283	GH-S-N-1124	DEFA09-60-283	GH-S-N-1125
DEFA09-20-287	GH-S-N-1126	DEFA09-34-287	GH-S-N-1127	DEFA09-60-287	GH-S-N-1128
DEFA09-20-291	GH-S-N-1129	DEFA09-34-291	GH-S-N-1130	DEFA09-60-291	GH-S-N-1131

*Extended delivery time

PROGRAMMING PG. 151-152

CHANGE BLADES PG. 153

HTC015

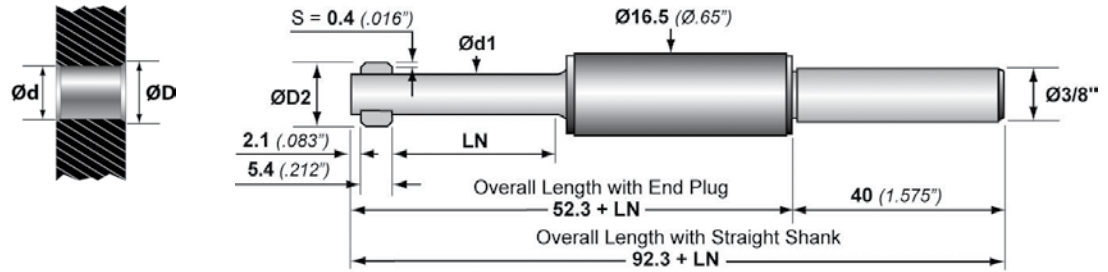

DEFA Series 10-11

$\varnothing d1 = \varnothing d_{min} - .2mm (.008")$

Min. Hole $\varnothing d$	Max Chamfer $\varnothing D$	Max $\varnothing D2$	Tool Holder without blades			TiAlN Blade Set	
			Order Number Short	Order Number Standard	Order Number Long	Order Number	Order Number
mm inches	mm inches	mm inches	LN = 20mm	LN = 34mm	LN = 60mm	Front/Back	Back only
7.7 .303	9.6 .378	10.4 .410	DEFA10-20-295-□/___	DEFA10-34-295-□/___	DEFA10-60-295-□/___	-3X10	-4X10
7.8 .307			DEFA10-20-299-□/___	DEFA10-34-299-□/___	DEFA10-60-299-□/___		
7.9 .311			DEFA10-20-303-□/___	DEFA10-34-303-□/___	DEFA10-60-303-□/___		
8.0 .315			DEFA10-20-307-□/___	DEFA10-34-307-□/___	DEFA10-60-307-□/___		
8.1 .319			DEFA10-20-311-□/___	DEFA10-34-311-□/___	DEFA10-60-311-□/___		
8.2 .323	10.4 .409	11.2 .441	DEFA11-20-315-□/___	DEFA11-34-315-□/___	DEFA11-60-315-□/___	-3X11	-4X11
8.3 .327			DEFA11-20-319-□/___	DEFA11-34-319-□/___	DEFA11-60-319-□/___		
8.4 .331			DEFA11-20-323-□/___	DEFA11-34-323-□/___	DEFA11-60-323-□/___		
8.5 .335			DEFA11-20-327-□/___	DEFA11-34-327-□/___	DEFA11-60-327-□/___		
8.6 .339			DEFA11-20-331-□/___	DEFA11-34-331-□/___	DEFA11-60-331-□/___		
8.7 .343			DEFA11-20-335-□/___	DEFA11-34-335-□/___	DEFA11-60-335-□/___		
8.8 .346			DEFA11-20-339-□/___	DEFA11-34-339-□/___	DEFA11-60-339-□/___		
8.9 .350			DEFA11-20-343-□/___	DEFA11-34-343-□/___	DEFA11-60-343-□/___		

To order the tool with a pre-set chamfer size, we recommend adding a calculated over-the-blade diameter ($\varnothing D2 = \varnothing D + .032"$) as a suffix to the order number, otherwise a calculated default dimension is used ($\varnothing D2 = .060" + \varnothing d1$).

The first tool in each series are STANDARD TOOLS which should be used when you have a stable set-up and are cutting any material under 28 Rc.

□ – Add “p” for tool with end plug.
Leave blank for tool with straight shank.
___ – Fill in your calculated over-the-blade diameter
 $\varnothing D2 = \varnothing D + .032"$ or $\varnothing D2 = \varnothing D + (2 \times s')$

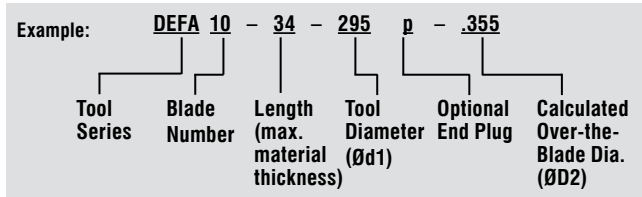

BLADE
OPTIONS **PG. 149**

SPARE
PARTS **PG. 137**

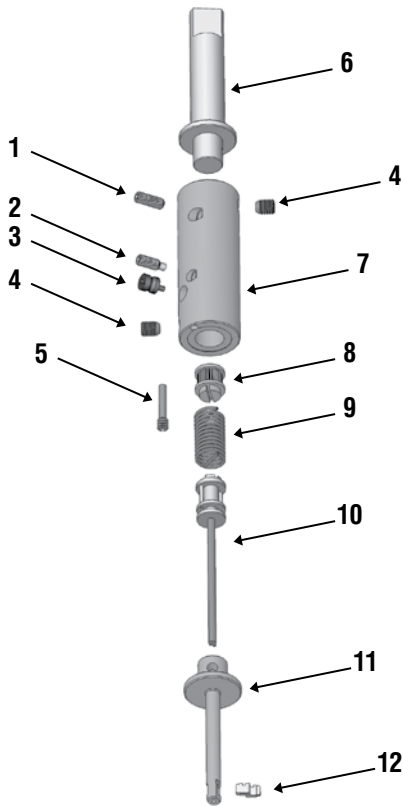

Spare Parts – DEFA Series 10-11

	Order Number	Description
1	GH-H-S-0101	Tension Screw
2	GH-H-S-0322	Set Screw
3	GH-S-E-0001	Eccentric Cam
4	GH-H-S-0201	Clamping Screw
5	GH-S-X-0001	Positioning Screw
6	GH-S-S-0155**	3/8" Straight Shank
	GH-S-S-0090**	End Plug
7	GH-S-G-0001	Tool Body
8	GH-S-C-0001	Gear Wheel
9	GH-S-T-0001	Torsion Spring
10	GH-S-W-0604	Blade Control-Length=20mm
	GH-S-W-0605	Blade Control-Length=34mm
	GH-S-W-0628*	Blade Control-Length=60mm
11	Blade Housing	See housing chart below
12	Blade Set	See table on pg. 136

*Non-stock standard item with extended delivery time.

**Tool bodies are sold with either a straight shank or end plug, please read the ordering instructions to indicate your preference. Other options are available and sold separately. Please contact engineering for details.

DEFA Series 10-11 – Blade Housing Chart*

Tool Holder Order Number	Blade Housing Order Number	Tool Holder Order Number	Blade Housing Order Number	Tool Holder Order Number	Blade Housing Order Number
DEFA10-20-295	GH-S-N-1150	DEFA10-34-295	GH-S-N-1151	DEFA10-60-295	GH-S-N-1152
DEFA10-20-299	GH-S-N-1153	DEFA10-34-299	GH-S-N-1154	DEFA10-60-299	GH-S-N-1155
DEFA10-20-303	GH-S-N-1156	DEFA10-34-303	GH-S-N-1157	DEFA10-60-303	GH-S-N-1158
DEFA10-20-307	GH-S-N-1159	DEFA10-34-307	GH-S-N-1160	DEFA10-60-307	GH-S-N-1161
DEFA10-20-311	GH-S-N-1162	DEFA10-34-311	GH-S-N-1163	DEFA10-60-311	GH-S-N-1164
DEFA11-20-315	GH-S-N-1165	DEFA11-34-315	GH-S-N-1166	DEFA11-60-315	GH-S-N-1167
DEFA11-20-319	GH-S-N-1168	DEFA11-34-319	GH-S-N-1169	DEFA11-60-319	GH-S-N-1170
DEFA11-20-323	GH-S-N-1171	DEFA11-34-323	GH-S-N-1172	DEFA11-60-323	GH-S-N-1173
DEFA11-20-327	GH-S-N-1174	DEFA11-34-327	GH-S-N-1175	DEFA11-60-327	GH-S-N-1176
DEFA11-20-331	GH-S-N-1177	DEFA11-34-331	GH-S-N-1178	DEFA11-60-331	GH-S-N-1179
DEFA11-20-335	GH-S-N-1180	DEFA11-34-335	GH-S-N-1181	DEFA11-60-335	GH-S-N-1182
DEFA11-20-339	GH-S-N-1183	DEFA11-34-339	GH-S-N-1184	DEFA11-60-339	GH-S-N-1185
DEFA11-20-343	GH-S-N-1186	DEFA11-34-343	GH-S-N-1187	DEFA11-60-343	GH-S-N-1188

*Extended delivery time

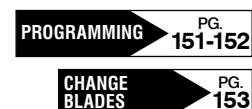

HTC015

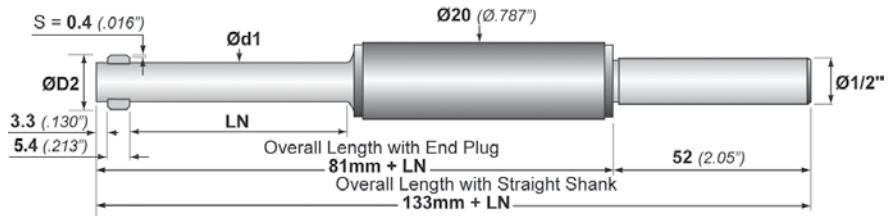
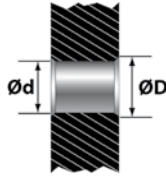

DEFA Series 12-13

Ød1 = Ødmin – .2mm (.008")

Min. Hole Ød	Max Chamfer ØD	Max ØD2	Tool Holder without blades			TiAlN Blade Set	
			Order Number Short	Order Number Standard	Order Number Long	Order Number	Order Number
mm inches	mm inches	mm inches	LN = 30mm	LN = 60mm	LN = 100mm	Front/Back	Back only
9.0 .354	12.0 .472	12.8 .504	DEFA12-30-346-□/___	DEFA12-60-346-□/___	DEFA12-100-346-□/___	-3X12	-4X12
9.1 .358			DEFA12-30-350-□/___	DEFA12-60-350-□/___	DEFA12-100-350-□/___		
9.2 .362			DEFA12-30-354-□/___	DEFA12-60-354-□/___	DEFA12-100-354-□/___		
9.3 .366			DEFA12-30-358-□/___	DEFA12-60-358-□/___	DEFA12-100-358-□/___		
9.4 .370			DEFA12-30-362-□/___	DEFA12-60-362-□/___	DEFA12-100-362-□/___		
9.5 .374			DEFA12-30-366-□/___	DEFA12-60-366-□/___	DEFA12-100-366-□/___		
9.6 .378			DEFA12-30-370-□/___	DEFA12-60-370-□/___	DEFA12-100-370-□/___		
9.7 .382			DEFA13-30-374-□/___	DEFA13-60-374-□/___	DEFA13-100-374-□/___		
9.8 .386	13.0 .512	13.8 .544	DEFA13-30-378-□/___	DEFA13-60-378-□/___	DEFA13-100-378-□/___	-3X13	-4X13
9.9 .390			DEFA13-30-382-□/___	DEFA13-60-382-□/___	DEFA13-100-382-□/___		
10.0 .394			DEFA13-30-386-□/___	DEFA13-60-386-□/___	DEFA13-100-386-□/___		
10.1 .398			DEFA13-30-390-□/___	DEFA13-60-390-□/___	DEFA13-100-390-□/___		
10.2 .402			DEFA13-30-394-□/___	DEFA13-60-394-□/___	DEFA13-100-394-□/___		
10.3 .406			DEFA13-30-398-□/___	DEFA13-60-398-□/___	DEFA13-100-398-□/___		
10.4 .409			DEFA13-30-402-□/___	DEFA13-60-402-□/___	DEFA13-100-402-□/___		
10.5 .413			DEFA13-30-406-□/___	DEFA13-60-406-□/___	DEFA13-100-406-□/___		
10.6 .417			DEFA13-30-409-□/___	DEFA13-60-409-□/___	DEFA13-100-409-□/___		
10.7 .421			DEFA13-30-413-□/___	DEFA13-60-413-□/___	DEFA13-100-413-□/___		
10.8 .425			DEFA13-30-417-□/___	DEFA13-60-417-□/___	DEFA13-100-417-□/___		
10.9 .429			DEFA13-30-421-□/___	DEFA13-60-421-□/___	DEFA13-100-421-□/___		
11.0 .433			DEFA13-30-425-□/___	DEFA13-60-425-□/___	DEFA13-100-425-□/___		
11.1 .437			DEFA13-30-429-□/___	DEFA13-60-429-□/___	DEFA13-100-429-□/___		

To order the tool with a pre-set chamfer size, we recommend adding a calculated over-the-blade diameter (ØD2 = ØD + .032") as a suffix to the order number, otherwise a calculated default dimension is used (ØD2 = .060" + Ød1).

The first tool in each series are STANDARD TOOLS which should be used when you have a stable set-up and are cutting any material under 28 Rc.

- – Add "p" for tool with end plug.
Leave blank for tool with straight shank.
- ___ – Fill in your calculated over-the-blade diameter
ØD2 = ØD + .032" or **ØD2 = ØD + (2x's')**

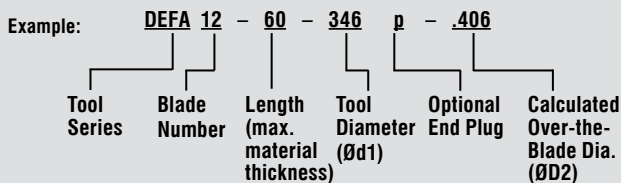

BLADE OPTIONS PG. 149

SPARE PARTS PG. 139

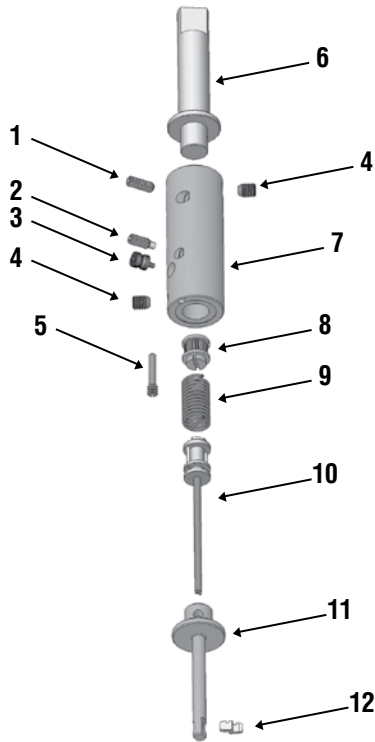

Spare Parts – DEFA Series 12-13

	Order Number	Description
1	GH-H-S-0102	Tension Screw
2	GH-H-S-0325	Set Screw
3	GH-S-E-0003	Eccentric Cam
4	GH-H-S-0201	Clamping Screw
5	GH-S-X-0006	Positioning Screw
6	GH-S-S-0156**	1/2" Straight Shank
	GH-S-S-0092**	End Plug
7	GH-S-G-0011	Tool Body
8	GH-S-C-0008	Gear Wheel
9	GH-S-T-0006	Torsion Spring
10	GH-S-W-0608	Blade Control-Length=30mm
	GH-S-W-0609	Blade Control-Length=60mm
	GH-S-W-0629*	Blade Control-Length=100mm
11	Blade Housing	See housing chart below
12	Blade Set	See table on pg. 138

*Non-stock standard item with extended delivery time.

**Tool bodies are sold with either a straight shank or end plug, please read the ordering instructions to indicate your preference. Other options are available and sold separately. Please contact engineering for details.

DEFA Series 12-13 – Blade Housing Chart*

Tool Holder Order Number	Blade Housing Order Number	Tool Holder Order Number	Blade Housing Order Number	Tool Holder Order Number	Blade Housing Order Number
DEFA12-30-346	GH-S-N-1216	DEFA12-60-346	GH-S-N-1217	DEFA12-100-346	GH-S-N-1218
DEFA12-30-350	GH-S-N-1219	DEFA12-60-350	GH-S-N-1220	DEFA12-100-350	GH-S-N-1221
DEFA12-30-354	GH-S-N-1222	DEFA12-60-354	GH-S-N-1223	DEFA12-100-354	GH-S-N-1224
DEFA12-30-358	GH-S-N-1225	DEFA12-60-358	GH-S-N-1226	DEFA12-100-358	GH-S-N-1227
DEFA12-30-362	GH-S-N-1228	DEFA12-60-362	GH-S-N-1229	DEFA12-100-362	GH-S-N-1230
DEFA12-30-366	GH-S-N-1231	DEFA12-60-366	GH-S-N-1232	DEFA12-100-366	GH-S-N-1233
DEFA12-30-370	GH-S-N-1234	DEFA12-60-370	GH-S-N-1235	DEFA12-100-370	GH-S-N-1236
DEFA13-30-374	GH-S-N-1237	DEFA13-60-374	GH-S-N-1238	DEFA13-100-374	GH-S-N-1239
DEFA13-30-378	GH-S-N-1240	DEFA13-60-378	GH-S-N-1241	DEFA13-100-378	GH-S-N-1242
DEFA13-30-382	GH-S-N-1243	DEFA13-60-382	GH-S-N-1244	DEFA13-100-382	GH-S-N-1245
DEFA13-30-386	GH-S-N-1246	DEFA13-60-386	GH-S-N-1247	DEFA13-100-386	GH-S-N-1248
DEFA13-30-390	GH-S-N-1249	DEFA13-60-390	GH-S-N-1250	DEFA13-100-390	GH-S-N-1251
DEFA13-30-394	GH-S-N-1252	DEFA13-60-394	GH-S-N-1253	DEFA13-100-394	GH-S-N-1254
DEFA13-30-398	GH-S-N-1255	DEFA13-60-398	GH-S-N-1256	DEFA13-100-398	GH-S-N-1257
DEFA13-30-402	GH-S-N-1258	DEFA13-60-402	GH-S-N-1259	DEFA13-100-402	GH-S-N-1260
DEFA13-30-406	GH-S-N-1261	DEFA13-60-406	GH-S-N-1262	DEFA13-100-406	GH-S-N-1263
DEFA13-30-409	GH-S-N-1264	DEFA13-60-409	GH-S-N-1265	DEFA13-100-409	GH-S-N-1266
DEFA13-30-413	GH-S-N-1267	DEFA13-60-413	GH-S-N-1268	DEFA13-100-413	GH-S-N-1269
DEFA13-30-417	GH-S-N-1270	DEFA13-60-417	GH-S-N-1271	DEFA13-100-417	GH-S-N-1272
DEFA13-30-421	GH-S-N-1273	DEFA13-60-421	GH-S-N-1274	DEFA13-100-421	GH-S-N-1275
DEFA13-30-425	GH-S-N-1276	DEFA13-60-425	GH-S-N-1277	DEFA13-100-425	GH-S-N-1278
DEFA13-30-429	GH-S-N-1279	DEFA13-60-429	GH-S-N-1280	DEFA13-100-429	GH-S-N-1281

*Extended delivery time

PROGRAMMING PG. 151-152

CHANGE BLADES PG. 153

HTC015

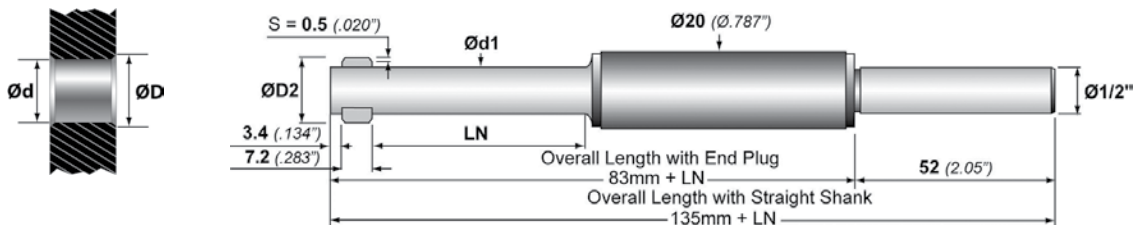

DEFA Series 14-15

Ød1 = Ødmin – .2mm (.008")

Min. Hole Ød	Max Chamfer ØD	Max ØD2	Tool Holder without blades			TiAlN Blade Set	
			Order Number Short	Order Number Standard	Order Number Long	Order Number	Order Number
mm inches	mm inches	mm inches	LN = 30mm	LN = 60mm	LN = 100mm	Front/Back	Back only
11.2 .441	14.6 .575	15.6 .615	DEFA14-30-433-□/___	DEFA14-60-433-□/___	DEFA14-100-433-□/___	-3X14	-4X14
11.3 .445			DEFA14-30-437-□/___	DEFA14-60-437-□/___	DEFA14-100-437-□/___		
11.4 .449			DEFA14-30-441-□/___	DEFA14-60-441-□/___	DEFA14-100-441-□/___		
11.5 .453			DEFA14-30-445-□/___	DEFA14-60-445-□/___	DEFA14-100-445-□/___		
11.6 .457			DEFA14-30-449-□/___	DEFA14-60-449-□/___	DEFA14-100-449-□/___		
11.7 .461			DEFA14-30-453-□/___	DEFA14-60-453-□/___	DEFA14-100-453-□/___		
11.8 .465			DEFA14-30-457-□/___	DEFA14-60-457-□/___	DEFA14-100-457-□/___		
11.9 .469			DEFA14-30-461-□/___	DEFA14-60-461-□/___	DEFA14-100-461-□/___		
12.0 .472			DEFA14-30-465-□/___	DEFA14-60-465-□/___	DEFA14-100-465-□/___		
12.1 .476			DEFA14-30-469-□/___	DEFA14-60-469-□/___	DEFA14-100-469-□/___		
12.2 .480			16.2 .638	17.2 .678	DEFA15-30-472-□/___		
12.3 .484	DEFA15-30-476-□/___	DEFA15-60-476-□/___			DEFA15-100-476-□/___		
12.4 .488	DEFA15-30-480-□/___	DEFA15-60-480-□/___			DEFA15-100-480-□/___		
12.5 .492	DEFA15-30-484-□/___	DEFA15-60-484-□/___			DEFA15-100-484-□/___		
12.6 .496	DEFA15-30-488-□/___	DEFA15-60-488-□/___			DEFA15-100-488-□/___		
12.7 .500	DEFA15-30-492-□/___	DEFA15-60-492-□/___			DEFA15-100-492-□/___		
12.8 .504	DEFA15-30-496-□/___	DEFA15-60-496-□/___			DEFA15-100-496-□/___		
12.9 .508	DEFA15-30-500-□/___	DEFA15-60-500-□/___			DEFA15-100-500-□/___		
13.0 .512	DEFA15-30-504-□/___	DEFA15-60-504-□/___			DEFA15-100-504-□/___		
13.1 .516	DEFA15-30-508-□/___	DEFA15-60-508-□/___			DEFA15-100-508-□/___		
13.2 .520	DEFA15-30-512-□/___	DEFA15-60-512-□/___			—		
13.3 .524	DEFA15-30-516-□/___	DEFA15-60-516-□/___			—		
13.4 .528	DEFA15-30-520-□/___	DEFA15-60-520-□/___			—		

To order the tool with a pre-set chamfer size, we recommend adding a calculated over-the-blade diameter (ØD2 = ØD + .040") as a suffix to the order number, otherwise a calculated default dimension is used (ØD2 = .068" + Ød1).

The first tool in each series are STANDARD TOOLS which should be used when you have a stable set-up and are cutting any material under 28 Rc.

□ – Add "p" for tool with end plug.
Leave blank for tool with straight shank.

___ – Fill in your calculated over-the-blade diameter
ØD2 = ØD + .040." or ØD2 = ØD + (2x's')

Example: **DEFA 14 - 60 - 433 p - .501**

Tool Series	Blade Number	Length (max. material thickness)	Tool Diameter (Ød1)	Optional End Plug	Calculated Over-the-Blade Dia. (ØD2)
-------------	--------------	----------------------------------	---------------------	-------------------	--------------------------------------

BLADE OPTIONS PG. 149

SPARE PARTS PG. 141

COFA | SNAP | VEX-S | VEX-P | COMBI | DEFA | GH-K | BSF | SOLO | GH-Z/E

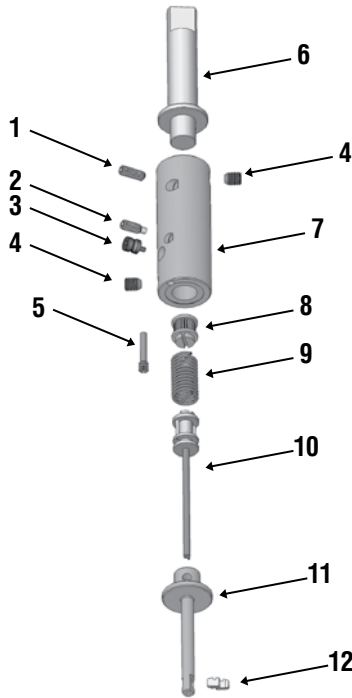

Spare Parts – DEFA Series 14-15

	Order Number	Description
1	GH-H-S-0102	Tension Screw
2	GH-H-S-0325	Set Screw
3	GH-S-E-0003	Eccentric Cam
4	GH-H-S-0201	Clamping Screw
5	GH-S-X-0006	Positioning Screw
6	GH-S-S-0156**	1/2" Straight Shank
	GH-S-S-0092**	End Plug
7	GH-S-G-0011	Tool Body
8	GH-S-C-0008	Gear Wheel
9	GH-S-T-0006	Torsion Spring
10	GH-S-W-0611	Blade Control-Length=30mm
	GH-S-W-0612	Blade Control-Length=60mm
	GH-S-W-0630*	Blade Control-Length=100mm
11	Blade Housing	See housing chart below
12	Blade Set	See table on pg. 140

*Non-stock standard item with extended delivery time.

**Tool bodies are sold with either a straight shank or end plug, please read the ordering instructions to indicate your preference. Other options are available and sold separately. Please contact engineering for details.

DEFA Series 14-15 – Blade Housing Chart*

Tool Holder Order Number	Blade Housing Order Number	Tool Holder Order Number	Blade Housing Order Number	Tool Holder Order Number	Blade Housing Order Number
DEFA14-30-433	GH-S-N-1327	DEFA14-60-433	GH-S-N-1328	DEFA14-100-433	GH-S-N-1329
DEFA14-30-437	GH-S-N-1330	DEFA14-60-437	GH-S-N-1331	DEFA14-100-437	GH-S-N-1332
DEFA14-30-441	GH-S-N-1333	DEFA14-60-441	GH-S-N-1334	DEFA14-100-441	GH-S-N-1335
DEFA14-30-445	GH-S-N-1336	DEFA14-60-445	GH-S-N-1337	DEFA14-100-445	GH-S-N-1338
DEFA14-30-449	GH-S-N-1339	DEFA14-60-449	GH-S-N-1340	DEFA14-100-449	GH-S-N-1341
DEFA14-30-453	GH-S-N-1342	DEFA14-60-453	GH-S-N-1343	DEFA14-100-453	GH-S-N-1344
DEFA14-30-457	GH-S-N-1345	DEFA14-60-457	GH-S-N-1346	DEFA14-100-457	GH-S-N-1347
DEFA14-30-461	GH-S-N-1348	DEFA14-60-461	GH-S-N-1349	DEFA14-100-461	GH-S-N-1350
DEFA14-30-465	GH-S-N-1351	DEFA14-60-465	GH-S-N-1352	DEFA14-100-465	GH-S-N-1353
DEFA14-30-469	GH-S-N-1354	DEFA14-60-469	GH-S-N-1355	DEFA14-100-469	GH-S-N-1356
DEFA15-30-472	GH-S-N-1357	DEFA15-60-472	GH-S-N-1358	DEFA15-100-472	GH-S-N-1359
DEFA15-30-476	GH-S-N-1360	DEFA15-60-476	GH-S-N-1361	DEFA15-100-476	GH-S-N-1362
DEFA15-30-480	GH-S-N-1363	DEFA15-60-480	GH-S-N-1364	DEFA15-100-480	GH-S-N-1365
DEFA15-30-484	GH-S-N-1366	DEFA15-60-484	GH-S-N-1367	DEFA15-100-484	GH-S-N-1368
DEFA15-30-488	GH-S-N-1369	DEFA15-60-488	GH-S-N-1370	DEFA15-100-488	GH-S-N-1371
DEFA15-30-492	GH-S-N-1372	DEFA15-60-492	GH-S-N-1373	DEFA15-100-492	GH-S-N-1374
DEFA15-30-496	GH-S-N-1375	DEFA15-60-496	GH-S-N-1376	DEFA15-100-496	GH-S-N-1377
DEFA15-30-500	GH-S-N-1378	DEFA15-60-500	GH-S-N-1379	DEFA15-100-500	GH-S-N-1380
DEFA15-30-504	GH-S-N-1381	DEFA15-60-504	GH-S-N-1382	DEFA15-100-504	GH-S-N-1383
DEFA15-30-508	GH-S-N-1384	DEFA15-60-508	GH-S-N-1385	DEFA15-100-508	GH-S-N-1386
DEFA15-30-512	GH-S-N-1387	DEFA15-60-512	GH-S-N-1388	—	—
DEFA15-30-516	GH-S-N-1390	DEFA15-60-516	GH-S-N-1391	—	—
DEFA15-30-520	GH-S-N-1393	DEFA15-60-520	GH-S-N-1394	—	—

*Extended delivery time

PROGRAMMING PG. 151-152

CHANGE BLADES PG. 153

HTC015

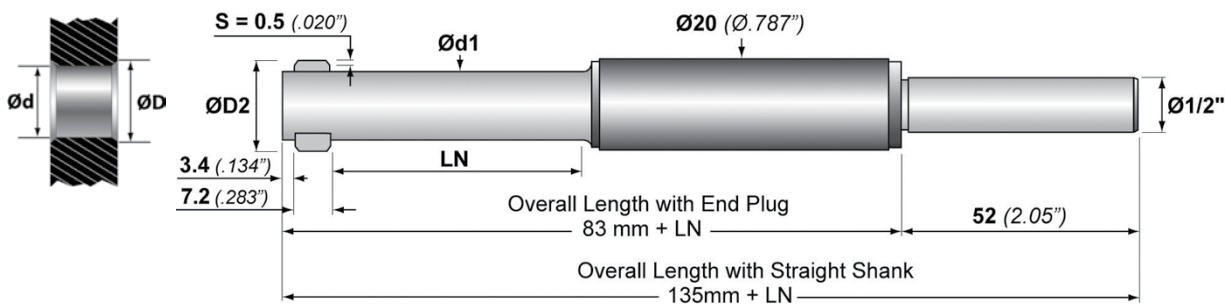

DEFA Series 16-17

Ød1 = Ødmin – .2mm (.008")

Min. Hole Ød	Max Chamfer ØD	Max ØD2	Tool Holder without blades			TiAlN Blade Set	
			Order Number Short	Order Number Standard	Order Number Long	Order Number	
mm inches	mm inches	mm inches	LN = 30mm	LN = 60mm	LN = 100mm	Front/Back	Back only
13.2 .520	17.6 .693	18.6 .733	DEFA16-30-512-□/___	DEFA16-60-512-□/___	DEFA16-100-512-□/___	-3X16	-4X16
13.4 .528			DEFA16-30-520-□/___	DEFA16-60-520-□/___	DEFA16-100-520-□/___		
13.6 .535			DEFA16-30-528-□/___	DEFA16-60-528-□/___	DEFA16-100-528-□/___		
13.8 .543			DEFA16-30-535-□/___	DEFA16-60-535-□/___	DEFA16-100-535-□/___		
14.0 .551			DEFA16-30-543-□/___	DEFA16-60-543-□/___	DEFA16-100-543-□/___		
14.2 .559			DEFA16-30-551-□/___	DEFA16-60-551-□/___	DEFA16-100-551-□/___		
14.4 .567			DEFA16-30-559-□/___	DEFA16-60-559-□/___	DEFA16-100-559-□/___		
14.6 .575			DEFA16-30-567-□/___	DEFA16-60-567-□/___	DEFA16-100-567-□/___		
14.8 .583			DEFA16-30-575-□/___	DEFA16-60-575-□/___	DEFA16-100-575-□/___		
15.0 .591			DEFA16-30-583-□/___	DEFA16-60-583-□/___	DEFA16-100-583-□/___		
15.2 .598			19.0 .748	20.0 .788	DEFA17-30-591-□/___		
15.4 .606	DEFA17-30-598-□/___	DEFA17-60-598-□/___			DEFA17-100-598-□/___		
15.6 .614	DEFA17-30-606-□/___	DEFA17-60-606-□/___			DEFA17-100-606-□/___		
15.8 .622	DEFA17-30-614-□/___	DEFA17-60-614-□/___			DEFA17-100-614-□/___		
16.0 .630	DEFA17-30-622-□/___	DEFA17-60-622-□/___			DEFA17-100-622-□/___		
16.2 .638	DEFA17-30-630-□/___	DEFA17-60-630-□/___			DEFA17-100-630-□/___		
16.4 .646	DEFA17-30-638-□/___	DEFA17-60-638-□/___			DEFA17-100-638-□/___		
16.6 .654	DEFA17-30-646-□/___	DEFA17-60-646-□/___			DEFA17-100-646-□/___		

To order the tool with a pre-set chamfer size, we recommend adding a calculated over-the-blade diameter ($\text{ØD2} = \text{ØD} + .040$) as a suffix to the order number, otherwise a calculated default dimension is used ($\text{ØD2} = .068 + \text{Ød1}$).

The first tool in each series are STANDARD TOOLS which should be used when you have a stable set-up and are cutting any material under 28 Rc.

□ – Add “p” for tool with end plug.
Leave blank for tool with straight shank.
___ – Fill in your calculated over-the-blade diameter
 $\text{ØD2} = \text{ØD} + .040$ ” or $\text{ØD2} = \text{ØD} + (2 \times \text{s})$

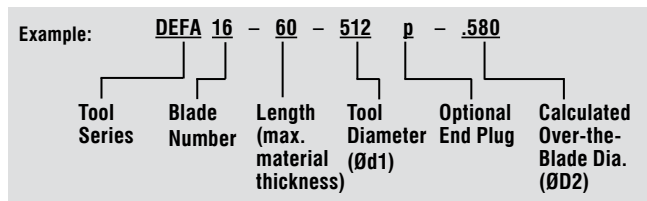

BLADE
OPTIONS **PG. 149**

SPARE
PARTS **PG. 143**

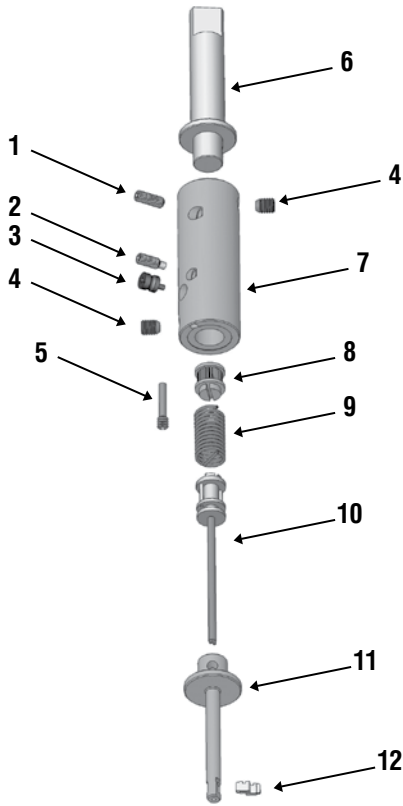

Spare Parts – DEFA Series 16-17

	Order Number	Description
1	GH-H-S-0102	Tension Screw
2	GH-H-S-0325	Set Screw
3	GH-S-E-0003	Eccentric Cam
4	GH-H-S-0201	Clamping Screw
5	GH-S-X-0006	Positioning Screw
6	GH-S-S-0156**	1/2" Straight Shank
	GH-S-S-0092**	End Plug
7	GH-S-G-0011	Tool Body
8	GH-S-C-0008	Gear Wheel
9	GH-S-T-0006	Torsion Spring
10	GH-S-W-0611	Blade Control-Length=30mm
	GH-S-W-0612	Blade Control-Length=60mm
	GH-S-W-0630*	Blade Control-Length=100mm
11	Blade Housing	See housing chart below
12	Blade Set	See table on pg. 142

*Non-stock standard item with extended delivery time.

**Tool bodies are sold with either a straight shank or end plug, please read the ordering instructions to indicate your preference. Other options are available and sold separately. Please contact engineering for details.

DEFA Series 16-17 – Blade Housing Chart*

Tool Holder Order Number	Blade Housing Order Number	Tool Holder Order Number	Blade Housing Order Number	Tool Holder Order Number	Blade Housing Order Number
DEFA16-30-512	GH-S-N-1465	DEFA16-60-512	GH-S-N-1466	DEFA16-100-512	GH-S-N-1467
DEFA16-30-520	GH-S-N-1471	DEFA16-60-520	GH-S-N-1472	DEFA16-100-520	GH-S-N-1473
DEFA16-30-528	GH-S-N-1477	DEFA16-60-528	GH-S-N-1478	DEFA16-100-528	GH-S-N-1479
DEFA16-30-535	GH-S-N-1483	DEFA16-60-535	GH-S-N-1484	DEFA16-100-535	GH-S-N-1485
DEFA16-30-543	GH-S-N-1489	DEFA16-60-543	GH-S-N-1490	DEFA16-100-543	GH-S-N-1491
DEFA16-30-551	GH-S-N-1495	DEFA16-60-551	GH-S-N-1496	DEFA16-100-551	GH-S-N-1497
DEFA16-30-559	GH-S-N-1501	DEFA16-60-559	GH-S-N-1502	DEFA16-100-559	GH-S-N-1503
DEFA16-30-567	GH-S-N-1507	DEFA16-60-567	GH-S-N-1508	DEFA16-100-567	GH-S-N-1509
DEFA16-30-575	GH-S-N-1513	DEFA16-60-575	GH-S-N-1514	DEFA16-100-575	GH-S-N-1515
DEFA16-30-583	GH-S-N-1519	DEFA16-60-583	GH-S-N-1520	DEFA16-100-583	GH-S-N-1521
DEFA17-30-591	GH-S-N-1525	DEFA17-60-591	GH-S-N-1526	DEFA17-100-591	GH-S-N-1527
DEFA17-30-598	GH-S-N-1531	DEFA17-60-598	GH-S-N-1532	DEFA17-100-598	GH-S-N-1533
DEFA17-30-606	GH-S-N-1537	DEFA17-60-606	GH-S-N-1538	DEFA17-100-606	GH-S-N-1539
DEFA17-30-614	GH-S-N-1543	DEFA17-60-614	GH-S-N-1544	DEFA17-100-614	GH-S-N-1545
DEFA17-30-622	GH-S-N-1549	DEFA17-60-622	GH-S-N-1550	DEFA17-100-622	GH-S-N-1551
DEFA17-30-630	GH-S-N-1555	DEFA17-60-630	GH-S-N-1556	DEFA17-100-630	GH-S-N-1557
DEFA17-30-638	GH-S-N-1561	DEFA17-60-638	GH-S-N-1562	DEFA17-100-638	GH-S-N-1563
DEFA17-30-646	GH-S-N-1567	DEFA17-60-646	GH-S-N-1568	DEFA17-100-646	GH-S-N-1569

*Extended delivery time

PROGRAMMING PG. 151-152

CHANGE BLADES PG. 153

HTC015

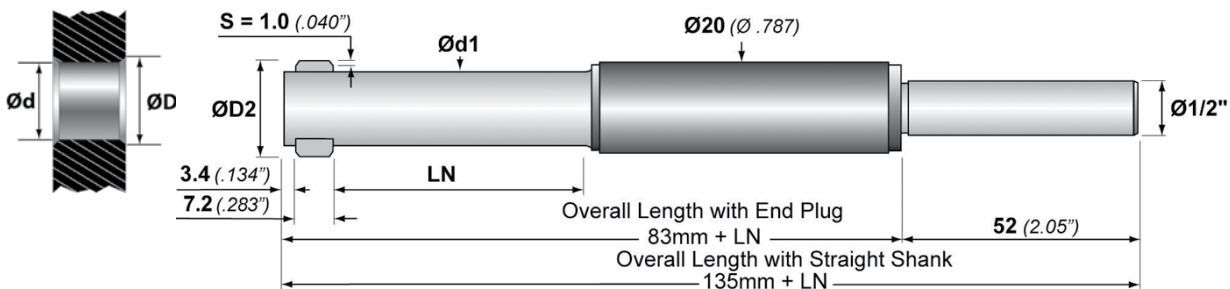

DEFA Series 18-19

$\varnothing d1 = \varnothing d_{min} - .2mm (.008")$

Min. Hole $\varnothing d$	Max Chamfer $\varnothing D$	Max $\varnothing D2$	Tool Holder without blades			TiAlN Blade Set					
			Order Number Short	Order Number Standard	Order Number Long	Order Number					
mm inches	mm inches	mm inches	LN = 30mm	LN = 60mm	LN = 100mm	Front/Back	Back only				
16.8 .661	21.8 .858	23.8 .938	DEFA18-30-654-□/___	DEFA18-60-654-□/___	DEFA18-100-654-□/___	-3X18	-4X18				
17.0 .669			DEFA18-30-661-□/___	DEFA18-60-661-□/___	DEFA18-100-661-□/___						
17.2 .677			DEFA18-30-669-□/___	DEFA18-60-669-□/___	DEFA18-100-669-□/___						
17.4 .685			DEFA18-30-677-□/___	DEFA18-60-677-□/___	DEFA18-100-677-□/___						
17.6 .693			DEFA18-30-685-□/___	DEFA18-60-685-□/___	DEFA18-100-685-□/___						
17.8 .701			DEFA18-30-693-□/___	DEFA18-60-693-□/___	DEFA18-100-693-□/___						
18.0 .709			DEFA18-30-701-□/___	DEFA18-60-701-□/___	DEFA18-100-701-□/___						
18.2 .717			DEFA18-30-709-□/___	DEFA18-60-709-□/___	DEFA18-100-709-□/___						
18.4 .724			DEFA18-30-717-□/___	DEFA18-60-717-□/___	DEFA18-100-717-□/___						
18.6 .732			DEFA18-30-724-□/___	DEFA18-60-724-□/___	DEFA18-100-724-□/___						
18.8 .740			24.2 .953	26.2 1.033	DEFA19-30-732-□/___			DEFA19-60-732-□/___	DEFA19-100-732-□/___	-3X19	-4X19
19.0 .748					DEFA19-30-740-□/___			DEFA19-60-740-□/___	DEFA19-100-740-□/___		
19.2 .756	DEFA19-30-748-□/___	DEFA19-60-748-□/___			DEFA19-100-748-□/___						
19.4 .764	DEFA19-30-756-□/___	DEFA19-60-756-□/___			DEFA19-100-756-□/___						
19.6 .772	DEFA19-30-764-□/___	DEFA19-60-764-□/___			DEFA19-100-764-□/___						
19.8 .780	DEFA19-30-772-□/___	DEFA19-60-772-□/___			DEFA19-100-772-□/___						
20.0 .787	DEFA19-30-780-□/___	DEFA19-60-780-□/___			DEFA19-100-780-□/___						
20.2 .795	DEFA19-30-787-□/___	DEFA19-60-787-□/___			DEFA19-100-787-□/___						
20.4 .803	DEFA19-30-795-□/___	DEFA19-60-795-□/___			DEFA19-100-795-□/___						

To order the tool with a pre-set chamfer size, we recommend adding a calculated over-the-blade diameter ($\varnothing D2 = \varnothing D + .080"$) as a suffix to the order number, otherwise a calculated default dimension is used ($\varnothing D2 = .108" + \varnothing d1$).

The first tool in each series are STANDARD TOOLS which should be used when you have a stable set-up and are cutting any material under 28 Rc.

□ – Add “p” for tool with end plug.
Leave blank for tool with straight shank.

___ – Fill in your calculated over-the-blade diameter
 $\varnothing D2 = \varnothing D + .080."$ or **$\varnothing D2 = \varnothing D + (2x's')$**

Example: **DEFA 18 - 60 - 654 p - .761**

Tool Series	Blade Number	Length (max. material thickness)	Tool Diameter ($\varnothing d1$)	Optional End Plug	Calculated Over-the-Blade Dia. ($\varnothing D2$)
-------------	--------------	----------------------------------	------------------------------------	-------------------	---

BLADE OPTIONS PG. 149

SPARE PARTS PG. 145

COFA | SNAP | VEX-S | VEX-P | COMBI | DEFA | GH-K | BSF | SOLO | GH-Z/E

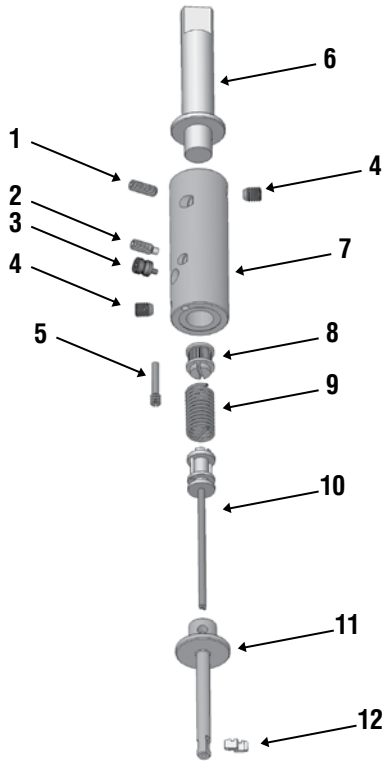

Spare Parts – DEFA Series 18-19

	Order Number	Description
1	GH-H-S-0102	Tension Screw
2	GH-H-S-0325 ¹	Set Screw
3	GH-S-E-0003	Eccentric Cam
4	GH-H-S-0201	Clamping Screw
5	GH-S-X-0006	Positioning Screw
6	GH-S-S-0156**	1/2" Straight Shank
	GH-S-S-0092**	End Plug
7	GH-S-G-0013	Tool Body
8	GH-S-C-0008	Gear Wheel
9	GH-S-T-0006	Torsion Spring
10	GH-S-W-0620	Blade Control-Length=30mm
	GH-S-W-0621	Blade Control-Length=60mm
	GH-S-W-0631*	Blade Control-Length=100mm
11	Blade Housing	See housing chart below
12	Blade Set	See table on pg. 144

*Non-stock standard item with extended delivery time.

**Tool bodies are sold with either a straight shank or end plug, please read the ordering instructions to indicate your preference. Other options are available and sold separately. Please contact engineering for details.

¹ Use set screw GH-H-S-0302 if ØD2 is greater than 22.5mm (.880") for Series 18 or 25.4mm (1.00") for Series 19.

DEFA Series 18-19 – Blade Housing Chart*

Tool Holder Order Number	Blade Housing Order Number	Tool Holder Order Number	Blade Housing Order Number	Tool Holder Order Number	Blade Housing Order Number
DEFA18-30-654	GH-S-N-1639	DEFA18-60-654	GH-S-N-1640	DEFA18-100-654	GH-S-N-1641
DEFA18-30-661	GH-S-N-1645	DEFA18-60-661	GH-S-N-1646	DEFA18-100-661	GH-S-N-1647
DEFA18-30-669	GH-S-N-1651	DEFA18-60-669	GH-S-N-1652	DEFA18-100-669	GH-S-N-1653
DEFA18-30-677	GH-S-N-1657	DEFA18-60-677	GH-S-N-1658	DEFA18-100-677	GH-S-N-1659
DEFA18-30-685	GH-S-N-1663	DEFA18-60-685	GH-S-N-1664	DEFA18-100-685	GH-S-N-1665
DEFA18-30-693	GH-S-N-1669	DEFA18-60-693	GH-S-N-1670	DEFA18-100-693	GH-S-N-1671
DEFA18-30-701	GH-S-N-1675	DEFA18-60-701	GH-S-N-1676	DEFA18-100-701	GH-S-N-1677
DEFA18-30-709	GH-S-N-1681	DEFA18-60-709	GH-S-N-1682	DEFA18-100-709	GH-S-N-1683
DEFA18-30-717	GH-S-N-1687	DEFA18-60-717	GH-S-N-1688	DEFA18-100-717	GH-S-N-1689
DEFA18-30-724	GH-S-N-1693	DEFA18-60-724	GH-S-N-1694	DEFA18-100-724	GH-S-N-1695
DEFA19-30-732	GH-S-N-1699	DEFA19-60-732	GH-S-N-1700	DEFA19-100-732	GH-S-N-1701
DEFA19-30-740	GH-S-N-1705	DEFA19-60-740	GH-S-N-1706	DEFA19-100-740	GH-S-N-1707
DEFA19-30-748	GH-S-N-1711	DEFA19-60-748	GH-S-N-1712	DEFA19-100-748	GH-S-N-1713
DEFA19-30-756	GH-S-N-1717	DEFA19-60-756	GH-S-N-1718	DEFA19-100-756	GH-S-N-1719
DEFA19-30-764	GH-S-N-1723	DEFA19-60-764	GH-S-N-1724	DEFA19-100-764	GH-S-N-1725
DEFA19-30-772	GH-S-N-1729	DEFA19-60-772	GH-S-N-1730	DEFA19-100-772	GH-S-N-1731
DEFA19-30-780	GH-S-N-1735	DEFA19-60-780	GH-S-N-1736	DEFA19-100-780	GH-S-N-1737
DEFA19-30-787	GH-S-N-1741	DEFA19-60-787	GH-S-N-1742	DEFA19-100-787	GH-S-N-1743
DEFA19-30-795	GH-S-N-1747	DEFA19-60-795	GH-S-N-1748	DEFA19-100-795	GH-S-N-1749

*Extended delivery time

PROGRAMMING PG. 151-152

CHANGE BLADES PG. 153

HTC015

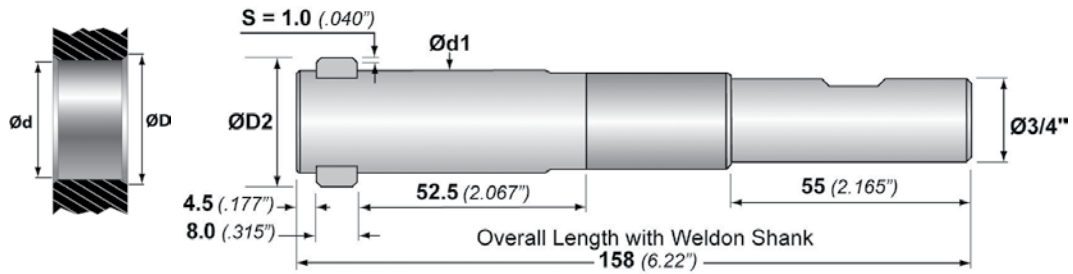

DEFA Series 22-24

$$\text{Ød1} = \text{Ødmin} - .2\text{mm} (.008\text{\"})$$

Min. Hole Ød	Max Chamfer ØD	Max ØD2	Tool Holder w/o Blades		Blade Set	
			Order Number	Order Number	Order Number	Order Number
mm inches	mm inches	mm inches			GH-S-M-	
20.7 .815	25.2 .992	27.2 1.072	DEFA22-807/___	-3X22	-4X22	
23.2 .913	27.5 1.083	29.5 1.163	DEFA24-906/___	-3X24	-4X24	

___ – Fill in your calculated over-the-blade diameter
 $\text{ØD2} = \text{ØD} + .080\text{\"}$ or $\text{ØD2} = \text{ØD} + (2x\text{'s})$

To order the tool with a pre-set chamfer size, we recommend adding a calculated over-the-blade diameter ($\text{ØD2} = \text{ØD} + .080\text{\"}$) as a suffix to the order number, otherwise a calculated default dimension is used as follows:

Series 22: $\text{ØD2} = 1.057\text{\"}$ (26.7mm)

Series 24: $\text{ØD2} = 1.120\text{\"}$ (28.4mm)

Spare Parts – DEFA Series 22-24*

	Order Number	Description	Series
1	GH-H-S-0201	Clamping Screw	22-24
2	GH-H-S-0102	Tension Screw	22
	GH-H-S-0103	Tension Screw	24
3	GH-H-S-0325	Set Screw	22-24
4	GH-S-E-0003	Ecclentric Cam	22
	GH-S-E-0004	Ecclentric Cam	24
5	GH-S-X-0006	Positioning Screw	22-24
6	GH-S-S-0157	3/4" Weldon Shank	22-24
7	GH-S-C-0008	Gear Wheel	22-24
8	GH-S-T-0006	Torsion Spring	22-24
9	GH-S-W-0014	Blade Control	22-24
10	GH-S-G-0023	Tool Body	22
	GH-S-G-0024	Tool Body	24
11	Blade Set	See table above	22-24

*Non-stock standard item with extended delivery time

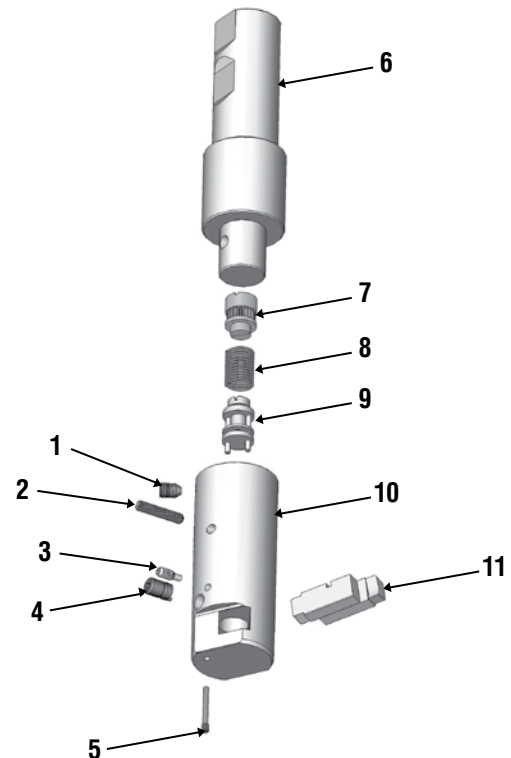

PROGRAMMING PG. 151-152

BLADE OPTIONS PG. 149

CHANGE BLADES PG. 153

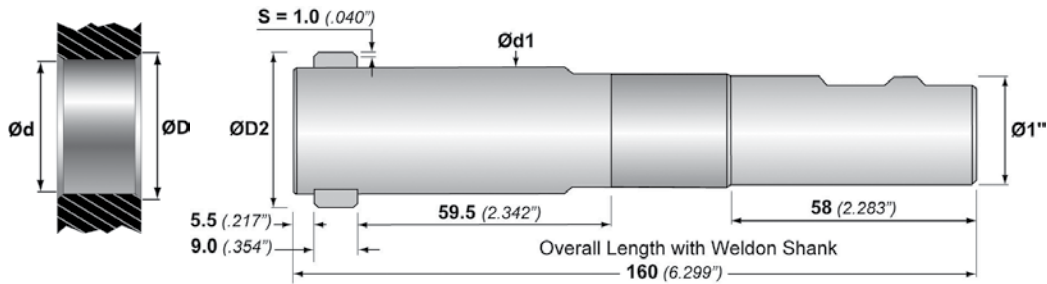

DEFA Series 26-28

$$\text{Ød1} = \text{Ødmin} - .2\text{mm} (.008\text{"})$$

Min. Hole Ød	Max Chamfer ØD	Max ØD2	Tool Holder w/o Blades		Blade Set	
			Order Number	Order Number Front/Back Back only		
26.2 1.031	31.8 1.252	33.8 1.331	DEFA26-1024/___	-3X26 -4X26	GH-S-M-	
29.2 1.150	34.8 1.370	36.8 1.449	DEFA28-1142/___	-3X28 -4X28		

___ – Fill in your calculated over-the-blade diameter
 $\text{ØD2} = \text{ØD} + .080\text{"}$ or $\text{ØD2} = \text{ØD} + (2 \times \text{s})$

To order the tool with a pre-set chamfer size, we recommend adding a calculated over-the-blade diameter ($\text{ØD2} = \text{ØD} + .080\text{"}$) as a suffix to the order number, otherwise a calculated default dimension is used as follows:

Series 26: $\text{ØD2} = 1.235\text{"}$ (31.3mm)

Series 28: $\text{ØD2} = 1.370\text{"}$ (34.8mm)

Spare Parts – DEFA Series 26-28*

	Order Number	Description	Series
1	GH-H-S-0202	Clamping Screw	26-28
2	GH-H-S-0105	Tension Screw	26
	GH-H-S-0106	Tension Screw	28
3	GH-H-S-0327	Set Screw	26-28
4	GH-S-E-0005	Ecclentric Cam	26
	GH-S-E-0006	Ecclentric Cam	28
5	GH-S-X-0007	Positioning Screw	26-28
6	GH-S-S-0163	1" Weldon Shank	26-28
7	GH-S-C-0009	Gear Wheel	26-28
8	GH-S-T-0007	Torsion Spring	26-28
9	GH-S-W-0015	Blade Control	26-28
10	GH-S-G-0025	Tool Body	26
	GH-S-G-0026	Tool Body	28
11	Blade Set	See table above	26-28

*Extended delivery time

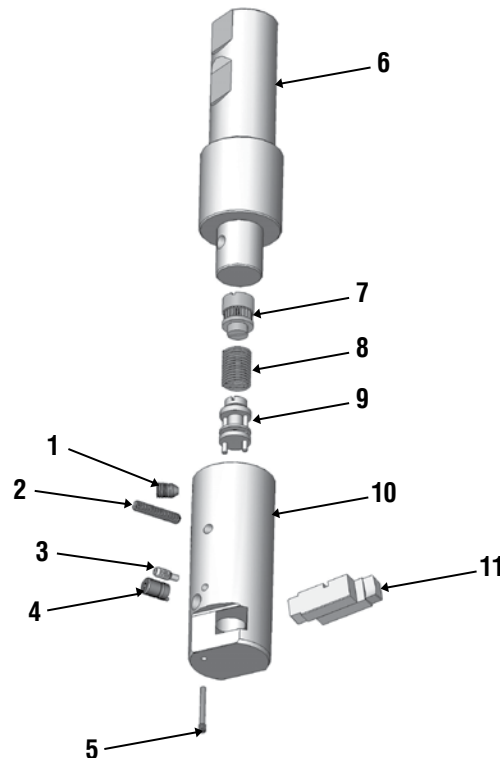

PROGRAMMING PG. 151-152

BLADE OPTIONS PG. 149

CHANGE BLADES PG. 153

HTC015

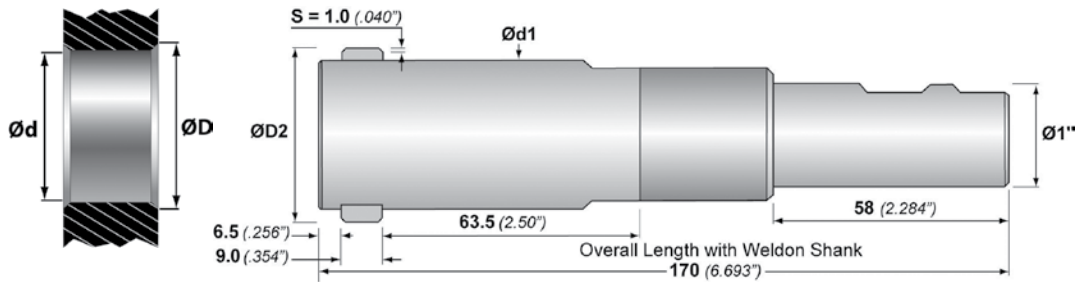

DEFA Series 30-32

$$\varnothing d1 = \varnothing d_{min} - .2mm (.008")$$

Min. Hole $\varnothing d$	Max Chamfer $\varnothing D$	Max $\varnothing D2$	Tool Holder w/o Blades		Blade Set	
			Order Number	Order Number	Front/Back	Back only
mm inches	mm inches	mm inches	GH-S-M-			
32.2 1.268	37.8 1.488	39.8 1.568	DEFA30-1260/___	-3X30	-4X30	
36.2 1.425	41.8 1.646	43.8 1.724	DEFA32-1417/___	-3X32	-4X32	

___ – Fill in your calculated over-the-blade diameter
 $\varnothing D2 = \varnothing D + .080."$ or $\varnothing D2 = \varnothing D + (2x's)$

To order the tool with a pre-set chamfer size, we recommend adding a calculated over-the-blade diameter ($\varnothing D2 = \varnothing D + .080"$) as a suffix to the order number, otherwise a calculated default dimension is used as follows:

Series 30: $\varnothing D2 = 1.495"$ (37.9mm)

Series 32: $\varnothing D2 = 1.620"$ (41.1mm)

Spare Parts – DEFA Series 30-32*

	Order Number	Description	Series
1	GH-H-S-0202	Clamping Screw	30-32
2	GH-H-S-0107	Tension Screw	30-32
3	GH-H-S-0327	Set Screw	30-32
4	GH-S-E-0007	Eccentric Cam	30
	GH-S-E-0008	Eccentric Cam	32
5	GH-S-X-0007	Positioning Screw	30-32
6	GH-S-S-0158	1" Weldon Shank	30-32
7	GH-S-C-0009	Gear Wheel	30-32
8	GH-S-T-0007	Torsion Spring	30-32
9	GH-S-W-0015	Blade Control	30-32
10	GH-S-G-0027	Tool Body	30
	GH-S-G-0028	Tool Body	32
11	Blade Set	See table above	30-32

*Non-stock standard item with extended delivery time

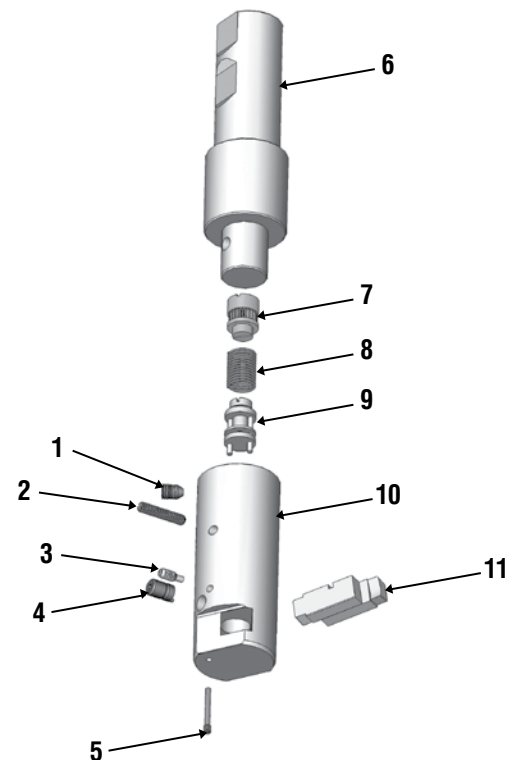

PROGRAMMING PG. 151-152

BLADE OPTIONS PG. 149

CHANGE BLADES PG. 153

Front and Back Chamfering

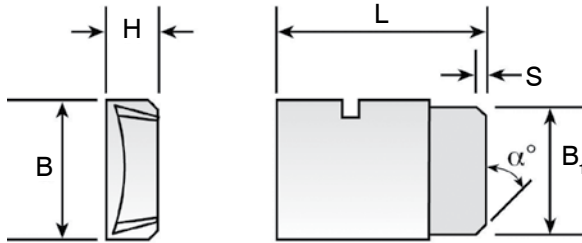

Back Chamfering Only

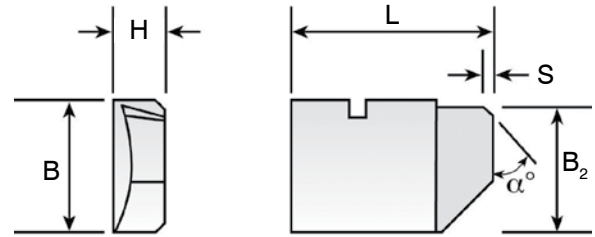

DEFA Blade Sets – Carbide- 90° (1 set = 2 pieces)

NEW (old) Series	TiN* F&B Chamfer GH-S-M-	Standard F&B Chamfer GH-S-M-	TiN* BCO GH-S-M-	Standard BCO GH-S-M-	S mm	L mm	B mm	H mm	B1 mm	B2 mm	Chamfer Angle
02 (4-4.8)	-3902	-3X02	-4902	-4X02	0.3	3.8					90°
03 (4.2-5.2)	-3903	-3X03	-4903	-4X03	0.3	3.95					
04 (4.6-5.8)	-3904	-3X04	-4904	-4X04	0.3	4.35	3.2	1.0	2.8	3.0	
05 (5-6.4)	-3905	-3X05	-4905	-4X05	0.3	4.8					
06 (5.5-6.8)	-3906	-3X06	-4906	-4X06	0.3	5.0					
07 (6-7)	-3907	-3X07	-4907	-4X07	0.3	5.6					
08 (6.5-7.5)	-3908	-3X08	-4908	-4X08	0.3	6.0	4.0	1.25	3.6	3.8	
09 (7-8)	-3909	-3X09	-4909	-4X09	0.3	6.4					
10 (8-9.5)	-3910	-3X10	-4910	-4X10	0.4	7.0					
11 (8.5-10)	-3911	-3X11	-4911	-4X11	0.4	7.4	6.0	1.5	5.4	5.7	
12 (9-12)	-3912	-3X12	-4912	-4X12	0.4	8.8					
13 (10-13)	-3913	-3X13	-4913	-4X13	0.4	9.2					
14 (12-14)	-3914	-3X14	-4914	-4X14	0.5	10.7					
15 (13-16)	-3915	-3X15	-4915	-4X15	0.5	11.5		2.0			
16 (14-17)	-3916	-3X16	-4916	-4X16	0.5	12.2					
17 (16-19)	-3917	-3X17	-4917	-4X17	0.5	12.9	8.0	3.0	7.2	7.6	
18 (17-21)	-3918	-3X18	-4918	-4X18	1.0	15.9		4.0			
19 (19-24)	-3919	-3X19	-4919	-4X19	1.0	17.1					
22 (21-25)	-3922	-3X22*	-4922	-4X22*	1.0	19.3	9.0	5.0	8.0	8.5	
24 (23-28)	-3924	-3X24*	-4924	-4X24*	1.0	20.4					
26 (26-32)	-3926	-3X26*	-4926	-4X26*	1.0	23.0					
28 (29-35)	-3928	-3X28*	-4928	-4X28*	1.0	24.6	10.0	6.0	9.0	9.5	
30 (32-38)	-3930	-3X30*	-4930	-4X30*	1.0	26.0					
32 (36-42)	-3932	-3X32*	-4932	-4X32*	1.0	28.1					

* Extended delivery item

**

Note:

Heule's 'X' blades use the latest TiAlN coating, it provides a stronger cutting edge and a more effective angle tolerance correction for harder to machine materials. 'X' blades can be used for all materials.

The D2 Dimension

Setting ØD2

The ØD2 is the measurement across the outer edge of the DEFA blades. The ØD2 can be adjusted by changing the position of the chamfer adjusting “Set Screw.” Use a pre-setter or calipers to measure across the outer edges of the blades when installed in the tool holder and adjust the “Set Screw” to get the proper dimension for ØD2.

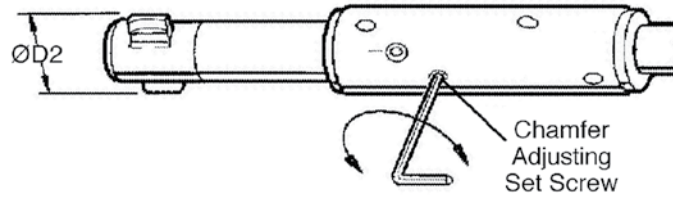

Calculating ØD2

ØD2 is the measurement across the outer sliding edge of the cutting blades when they are installed in the tool holder. ØD2 is based on the desired chamfer diameter, ØD, and the projected length of the non-cutting guiding edge, ‘s’.

$$\text{ØD2} = \text{ØD} + 2(\text{S})$$

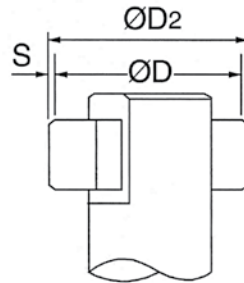

$$\text{ØD2} = \text{Chamfer Dia. (ØD)} + [2 \times \text{'s'}]$$

Series	Values for ‘s’	
	Old Series	‘s’
02 thru 09	4 thru 8	0.3mm .012”
10 thru 13	8 thru 13	0.4mm .016”
14 thru 17	12 thru 19	0.5mm .020”
18 thru 32	17 thru 42	1.0mm .040”

Adjusting ØD2

- Remove the red sealant from the chamfer adjusting set screw.
- To increase the ØD2 dimension, turn the set screw counter-clockwise.
- To decrease the ØD2 dimension, turn the set screw clockwise.
- Reapply screw sealant to the set screw to prevent unintentional changes.

Hint: When setting the ØD2, increase the blade tension to ensure maximum extension of the blades against the calipers.

Programming Information

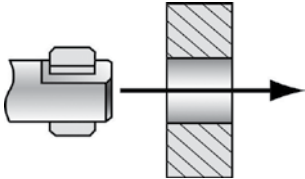
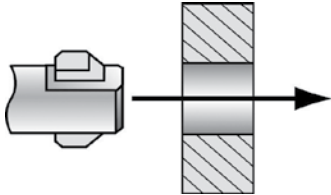
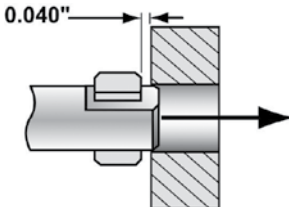
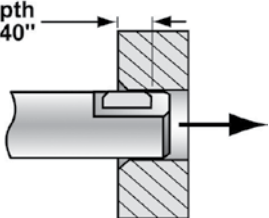
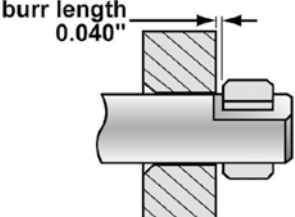
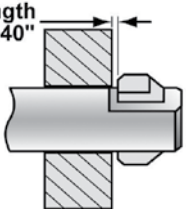
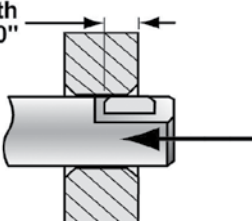
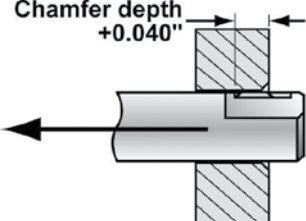
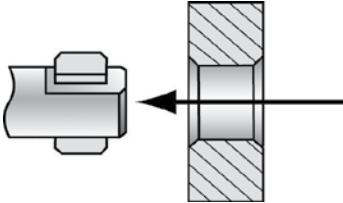
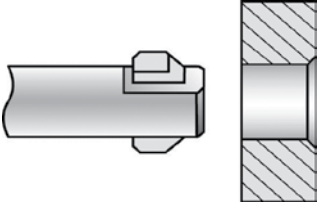
For Front & Back Chamfer		Back Chamfer Only
	<p>Step 1: See Feed and Speed chart on next page for proper parameters.</p>	
 <p>0.040"</p>	<p>Step 2: (Rapid into position) Move the tool with rapid feed into position with the front of the cutting blade 0.040" above the part.</p>	<p>N/A</p>
 <p>Chamfer depth 0.040"</p>	<p>Step 3: (Cut front chamfer) Machine the part with cutting feed (cf) and speed (cs). Feed into the part the chamfer depth +0.040" to ensure the blade has finished cutting.</p>	<p>N/A</p>
 <p>burr length 0.040"</p>	<p>Step 4: (Rapid to back) Move the tool through the part with rapid feed (rf) so the blade is 0.040" beyond the burr. The blade will not mark nor damage the through hole.</p>	 <p>burr length +0.040"</p>
 <p>Chamfer depth 0.040"</p>	<p>Step 5: (Cut back chamfer) Machine the part with back cutting feed (cf) and speed (cs). Feed into part the chamfer depth +0.040" to ensure the blade has finished cutting the back chamfer.</p>	 <p>Chamfer depth +0.040"</p>
	<p>Step 6: (Remove from the part) Remove the tool from the hole with rapid feed and proceed to the next hole. The blade will not mark nor damage the through hole.</p>	

While the DEFA tool is designed to handle almost any size of breakout burr, poor machining procedures may result in an excessively large, extruded burr which are extremely hard and difficult to machine. Timely replacement of dull drills and reamers as well as sufficient coolant supply can help control the burr size extending the life of the chamfer tool and improve chamfer quality.

Programming – Feed and Speeds

Material		Feed IPR	Speed - SFM Carbide - TiN
Aluminum	150<Bn<250	.001-.003	300-400
Brass	150<Bn<250	.001-.003	240-315
Low Carbon Steel	100<Bn<225	.001-.003	200-260
Med. Carbon Steel	150<Bn<250	.001-.003	100-240
Free Machining Alloy	150<Bn<250	.001-.003	140-200
High Alloy Steel*	200<Bn<350	.001-.003	100-130
Steel Casting	90<Bn<225	.001-.003	80-160
	150<Bn<250	.001-.003	80-130
Stainless Steel	150<Bn<250	.001-.003	100-150
	110<Bn<145	.001-.003	100-210
Malleable Cast Iron	150<Bn<270	.001-.003	125-185
	150<Bn<220	.001-.003	180-240
Gray Cast Iron	200<Bn<330	.001-.003	140-210
	150<Bn<250	.001-.003	180-150
Nodular Cast Iron	200<Bn<300	.001-.003	140-210
	22<Rc<32	.0008-.0015	30-80
Nickel Base Alloy*	32<Rc<42	.0008-.0015	20-50
	14<Rc<22	.0008-.0015	60-90
Titanium Alloy	22<Rc<32	.0008-.0015	60-90

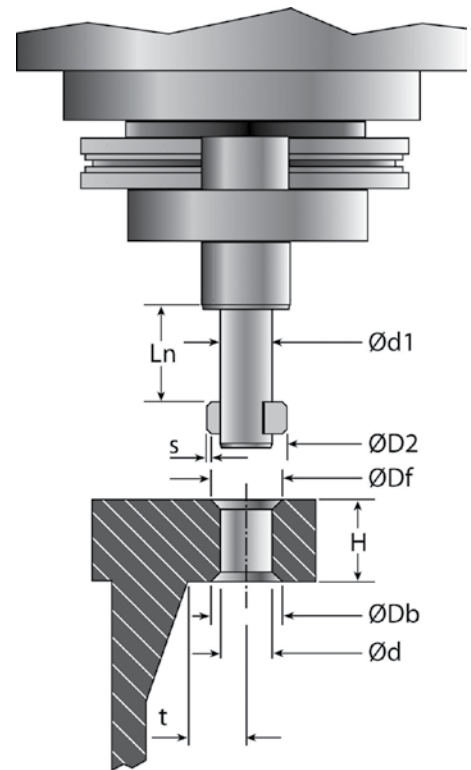

*When machining materials with a hardness greater than 28Rc, Heule recommends using a tool with the blade housing sized .006" under the hole size. Call Heule Tool engineering department for more info.

Key Terms

- Ød1** Blade Housing diameter
- ØD2** Over-the-blade diameter setting
- ØD** Chamfer diameter
 - ØD(f) – Front chamfer diameter
 - ØD(b) – Back chamfer diameter
- Ød** Hole diameter (in process)
- s** Definition surface width (non-cutting portion)
- L_n** Working Length
- H** Workpiece thickness
- t** Clearance from interferences

Formulas and Guidelines

- ØD2 = ØD + [2 x 's']**
- ØD <** Maximum chamfer diameter is shown for each tool size. DO NOT EXCEED THIS VALUE!
- H < L_n** (use shortest standard L_n value possible)
- t > ØD2/2**
- Recommended (for materials above 28 Rc):
 - min: **Ød1 = Ød (mean) - .006"**
 - max: **Ød1 = Ød - .012"**

<p>Eccentric Blade Control Control Pins</p>	<p>Step 1: With a 1.5mm Allen wrench, turn the eccentric 180° until the eccentric notch is opposite the tool body notch. The blade control will be lifted so the control pins release the blades.</p>
<p>Blade Set</p>	<p>Step 2: Remove the blades from the housing.</p>
<p>Blade Set</p>	<p>Step 3: Insert the clean new blade set so they are nearly flush with the blade housing. Ensure the notches are in the proper orientation.</p>
<p>Eccentric Control Pins</p>	<p>Step 4: Turn the eccentric back towards the tool body notch until a slight resistance is left. DO NOT USE FORCE!</p>
	<p>Step 5: Slide one blade then the other until control pins engage the blades. Check that both blades move simultaneously.</p>

Is there another way?

- With a #8 Torx Driver, remove the clamping screw and lift the blade housing.
- Remove the old blades by pushing them through the window.
- Turn the blade housing ¼ turn to the right by observing the clamping screw hole in the blade housing and the clamping screw.
- Insert the new blade set into the blade window so that they are flush with the diameter of the housing.
- Let the housing down and gently wiggle it back and forth until the control pins engage and the housing sits flush with the tool body. DO NOT USE FORCE!
- Ensure the clamping screw hole is aligned with the clamping screw and tighten the screw with a #8 Torx Driver.

NOTE:

Slide one blade then the other until control pins engage the blades. Check that both blades move simultaneously.

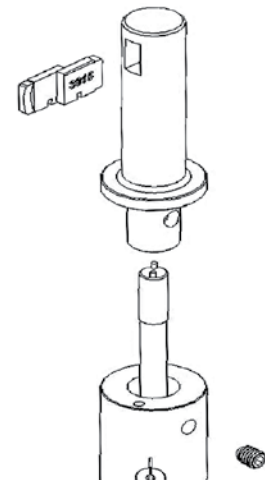

Setting Blade Force

How much Blade Force is enough?

The blade force does not affect the chamfer size. The blade force merely ensures that the blades open to their full diameter after passing through the hole. It should be possible to press the blades into the tool easily with the fingers. When released, the blades should snap out to the diameter set as the ØD2.

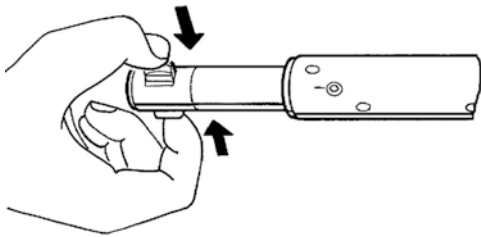

How to adjust the Blade Force

The tool body has a “tension screw” which can be used to adjust the force behind the blades. By turning this screw, the force will be increased or decreased.

- To increase the blade force, turn the “tension screw” clockwise.
- To decrease the blade force, turn the “tension screw” counter-clockwise.

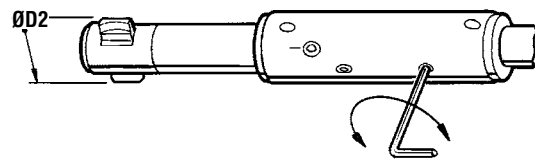

How to check the Blade Force

If the DEFA tools are being setup by various operators and consistency in setting the blade force is desired, the HEULE DPM3 Force Caliper Gage is recommended.

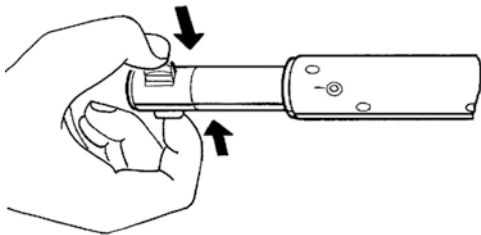

The HEULE DPM3 Force Caliper Gage is battery operated and uses a digital readout to display the force required to push the blades into the tool.

Using the DPM3 assures consistency in tool setup when several operators are using the same tooling.

When measuring with the DPM3, the recommended force is 8-12 newtons for the DEFA tools.



DPM3 Order Number:
DPM3-US

What do the screws do?

- 1) Clamping Screw (Blade Housing) – Holds the blade housing to the tool body. It must seat at the tapered pocket in the housing for maximum holding force.
- 2) Eccentric Cam – Disengages and engages the blade control pins from the blades making it possible to exchange the blades easily.
- 3) Set Screw (Chamfer adjusting) – Adjusts ØD2 setting and chamfer ØD. Turn clockwise to decrease chamfer, counter-clockwise to increase chamfer.
- 4) Tension Screw – Adjusts the force behind the blades. Turn clockwise to increase tension, counter-clockwise to decrease tension.
- 5) Clamping Screw (Shank) – Holds the shank to the tool body. It must seat in the tapered pocket in the shank for maximum holding force.

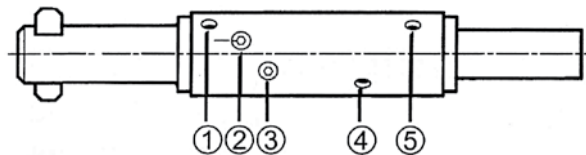

GH-K



Interchangeable Blade Countersink Tool For Large Chatter-free Countersinks

- Replaceable blades simplify use
- Regrindable blades provide increased cost savings
- Chamfer milling capabilities
- Creates countersinks from 3mm-45mm (1/8"-1 3/4")

The GH-K tool is a precision inserted countersink tool with one or three effective cutting edges and large countersink range. Positive geometry allows for high shear cutting action. Carbide blades are best suited for cast iron, aluminum and other non-ferrous materials and HSS-Cobalt coated blades are used for stainless and steel applications.

Replaceable Blades

Replaceable blades are an economical choice and the GH-K blades can be reground using the available fixture. Three bladed sets are ground in sets and numerically marked and should not be separated. Each blade cuts at the same time reducing any chance of chatter.



Chamfer Milling

GH-K can be used to conventional mill chamfers around the perimeter of a larger hole or the entire part. The short radial clearance reduces chatter and improves surface finish. Three bladed tools are suited for manual or CNC applications while the economical single bladed tool is designed for all machining centers.

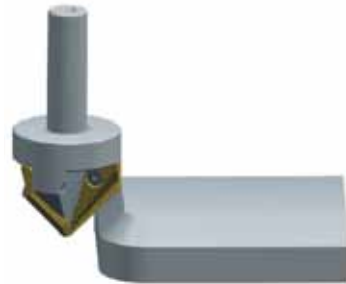

Large Chamfer Range

GH-K tooling can be used for hole sizes as small as .118" (3mm) diameter and produce countersinks as large as 1.771" (45mm) diameter. Standard tooling is available from stock.

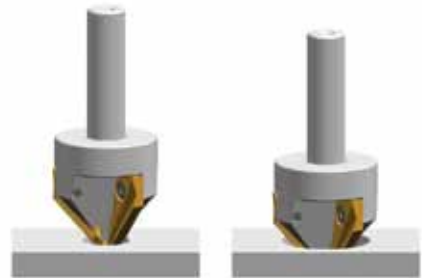

How Does It Work?

Feed the tool into the part. The blade(s) start cutting once the tip reaches the part. Continue to feed the tool until the desired countersink size is achieved, then rapid the tool out of the part. The GH-K tool provides precision cut countersinks without chatter due to the shallow radial clearance which may require controlled feed rates. Shims can be added when more aggressive feed rates are required.

Typical Parts

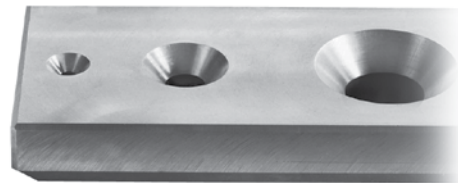

How to Order

1. Select the appropriate tool body based on the required countersink size.
2. Select the appropriate blades based on the material and desired countersink angle.

NOTE: Choose the triple bladed tool in all manual feed operations.

Regrindable Cutting Blades

To increase the economy of the precision countersinking tool, the single and triple blades can be reground to original accuracy using available re-grind fixtures.

When regrounding pay attention to the following details:

- Triple blade sets are matched and numbered. These numbered sets should be kept as a set of three.
- Regrind the 30° radial rake only enough to renew a sharp edge. The maximum regrind depth is 1.0mm for GH-K25 and 1.4mm for GH-K45.
- Appropriate safety measures should be used when grinding Carbide.



Grinding may produce hazardous dust. To avoid adverse effects, use adequate ventilation and read MSDS. Cutting tools may break during use. To avoid injury, use proper safety precautions and protective equipment. Use the machine tool with sufficient rigidity and horsepower. Use a cover on a machine tool and protector, such as glasses, against shattering chips and broken tools due to misuse. Do not use insoluble oil because there is a danger of causing fire.

Ø25 Three and Single Bladed Countersink Tool with Through Coolant

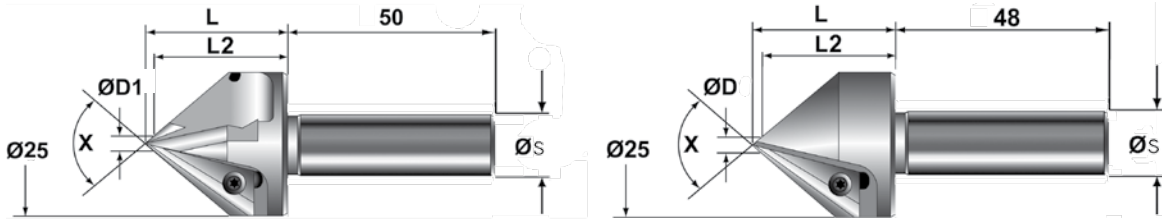

THREE BLADED TOOL BODY & CUTTING BLADES							
Size	Angle (X)	ØD	L	L2	Shank Øs	Three Bladed Description	Order Number
GHK 25	100°	3	25.82	24.56	10mm	Tool Body GH-K25/100° w/10mm shank	GH-K-O-0109
						Blade Set*, HSS-TiN	GH-K-M-0001
						Blade Set*, Carbide	GH-K-M-0007
						Blade Set*, Carbide-TiN	GH-K-M-0017
						Shim, 0.05mm thick, trio	GH-K-U-0001
GHK 25	90°	3	26.37	24.87	10mm	Tool Body GH-K25/90° w/10mm shank	GH-K-B-0001
						Blade Set*, HSS-TiN	GH-K-M-0001
						Blade Set*, Carbide	GH-K-M-0007
						Blade Set*, Carbide-TiN	GH-K-M-0017
						Shim, 0.05mm thick, trio	GH-K-U-0001
GHK 25	82°	5	28.45	25.57	12mm	Tool Body GH-K25/82° w/12mm shank	GH-K-O-0016
						Blade Set*, Carbide	GH-K-M-0070
						Blade Set*, Carbide-TiALN	GH-K-M-0074
						Shim, 0.05mm thick, trio	GH-K-U-0001
GHK 25	60°	3	35.65	33.05	10mm	Tool Body GH-K25/60° w/10mm shank	GH-K-B-0601
						Blade Set*, Carbide	GH-K-M-0607
						Blade Set*, Carbide-TiN	GH-K-M-0617
						Shim, 0.05mm thick, trio	GH-K-U-0004
SINGLE BLADED TOOL BODY & CUTTING BLADES							
Size	Angle (X)	ØD	L	L2	Shank Øs	Single Bladed Description	Order Number
GHK 25	90°	3	26.32	24.82	10mm	Tool Body GH-K25/90° w/10mm shank	GH-K-B-0010
						Tool Body GH-K25/90° w/3/8" shank	GH-K-B-0008
						Blade*, HSS-TiN	GH-K-M-0022
						Blade*, Carbide	GH-K-M-0023
						Blade*, Carbide-TiN	GH-K-M-0024
						Shim, 0.05mm thick, trio	GH-K-U-0001

*** IMPORTANT NOTE:** All tool bodies are sold without cutting blades.

Single bladed countersink tools; cutting blades are sold per piece .

Three bladed countersink tools; cutting blades are sold and packaged in sets of three (trio) i.e. 1 set = 3pcs.

Max 82° cutting diameter Ø23.5

Spare Parts

GH-K 25	90° regrind fixture	GH-K-V-0020	Torx screw GH-K25 GH-H-S-0008	Torx driver T9 GH-H-S-2014
	82° regrind fixture	GH-K-V-0133		
	60° regrind fixture	GH-K-V-0023		

*** NOTE:** 100° holders use standard 90° blades.

Uncoated carbide can be requested with alternative coatings.

Contact Heule Tool Engineering for more information.

PROGRAMMING PG. 160

CHANGE BLADES PG. 160

Ø45 Three and Single Bladed Countersink Tool with Through Coolant

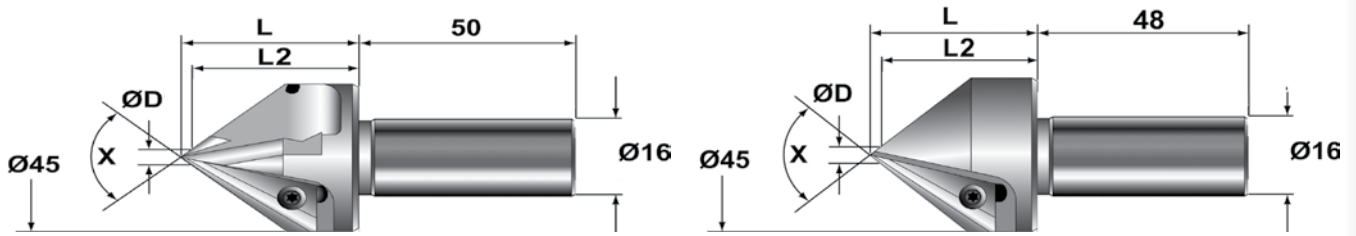

THREE BLADED TOOL BODY & CUTTING BLADES							
Size	Angle (X)	ØD	L	L2	Shank Øs	Three Bladed Description	Order Number
GHK 45	100°	5	46.1	44.0	16mm	Tool Body GH-K45/100° w/16mm shank	GH-K-O-0108
						Blade Set*, HSS-TiN	GH-K-M-0002
						Blade Set*, Carbide	GH-K-M-0008
						Blade Set*, Carbide-TiN	GH-K-M-0018
						Shim, 0.05mm thick, trio	GH-K-U-0002
GHK 45	90°	4	46.56	44.56	16mm	Tool Body GH-K45/90° w/16mm shank	GH-K-B-0012
						Blade Set*, HSS-TiN	GH-K-M-0002
						Blade Set*, Carbide	GH-K-M-0008
						Blade Set*, Carbide-TiN	GH-K-M-0018
						Shim, 0.05mm thick, trio	GH-K-U-0002
GHK 45	60°	9	63.03	55.23	16mm	Tool Body GH-K45/60° w/16mm shank	GH-K-B-0612
						Blade Set*, Carbide	GH-K-M-0608
						Blade Set*, Carbide-TiN	GH-K-M-0618
						Shim, 0.05mm thick, trio	GH-K-U-0005
						SINGLE BLADED TOOL BODY & CUTTING BLADES	
Size	Angle (X)	ØD	L	L	Shank Øs	Single Bladed Description	Order Number
GHK 45	90°	4	46.6	44.6	16mm	Tool Body GH-K45/90° w/16mm shank	GH-K-B-0011
						Blade*, HSS-TiN	GH-K-M-0028
						Blade*, Carbide	GH-K-M-0029
						Blade*, Carbide-TiN	GH-K-M-0030
						Shim, 0.05mm thick, trio	GH-K-U-0002

*** IMPORTANT NOTE:** All tool bodies are sold without cutting blades.

Single bladed countersink tools; cutting blades are sold per piece .

Three bladed countersink tools; cutting blades are sold and packaged in sets of three (trio) i.e. 1 set = 3pcs.

ØD = Minimum recommended countersink

*Use single blade design only with power feed and stable ridge set-up

Spare Parts				
GH-K 45	90° regrind fixture	GH-K-V-0021	<u>Torx screw GH-K45</u>	<u>Torx driver T15</u>
	60° regrind fixture	GH-K-V-0024	GH-H-S-0009	GH-H-S-2016

*** NOTE:** 100° holders use standard 90° blades.

Uncoated carbide can be requested with alternative coatings.

Contact Heule Tool Engineering for more information.

PROGRAMMING PG. 160

CHANGE BLADES PG. 160

Programming Information

Power feed control is suggested to prevent overfeeding the single blade tool. Overfeeding the tool can damage the cutting blade and possibly the tool. Shims can be added behind the cutting blade to increase front clearance.

GH-K Programming				
Feed:	0.002" (0.05mm) per blade. Depending upon the material and machine rigidity, or with the use of shims, the feed rate can be increased.			
Speed:	Material	HSS-TiN	Carbide	Carbide-TiN
(SFM)*	Aluminum	80-230	80-360	100-450
	Cast Iron	50-100	65-125	100-250
	Carbon Steel	33-65	50-100*	82-125*
	Stainless Steel	30-50	35-65*	45-80*

*based on countersink diameter

*Optional Geometry available on request, contact Heule Tool Engineering

Replacing GH-K Blades

1. Unscrew the screw for each blade that attaches it to the tool body.
2. Place the new blade on the tool body and insert the screw.
Repeat for each blade.

NOTE: Be sure to replace the entire set of blades and not just one single blade as they come in sets and are



Calculation Reference

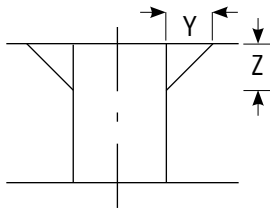

	Z	Y
60°	1	.577
82°	1	.869
90°	1	1.00
100°	1	1.191

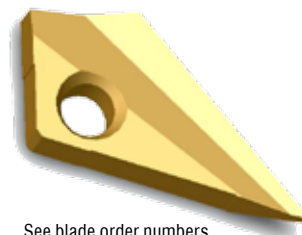

See blade order numbers on pages 158 and 159

BSF

Large Ratio Automatic Back Counterboring & Spotfacing Tool

- Counterbores up to 2.3xd
- Replaceable carbide coated blades for extended life
- Very simple to use
- Suitable for CNC machines with through coolant
- Sizes 6.5-20.5mm (.256-.807") available from stock



How Does the BSF Tool Work?

BSF (Back Spot Facer) is an economical backwards counterboring tool. It allows the machining of large spotfaces and counterbores without turning the work piece over. This means that the machining is done on the same side as the drilled hole. The BSF is specifically designed for CNC machining and functions without an anti-rotation device, change of spindle direction or contact mechanism. The blade expands using centrifugal force when activating the spindle. The blade retracts by coolant pressure. The coolant pressure moves a piston which is pushing a pin that forces the blade (closed) into the blade housing. The design of the BSF focuses on optimal cutting performance, chip removal and reliability. The tool and the blade have special coolant pipes and chip guiding geometries that continuously flush the blade window and the blade itself with coolant. This keeps the whole section clean and allows for optimal chip removal performance. The tool is a has a very simplistic design but is also very robust due to the coolant pressure.

Easy to Change Carbide Cutting Blades

Changing the blade is easily executed with an assembly pin that is included with each tool. An extra split pin is included with each blade that is ordered. See page 194 for more information.

Tool Description

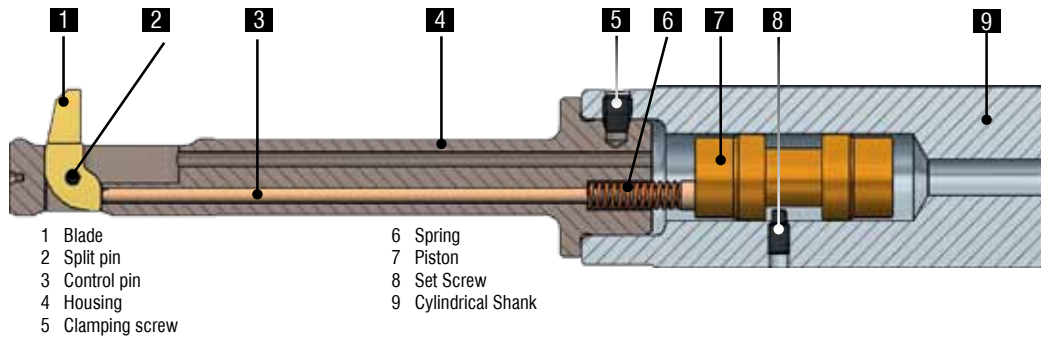

How to Order

The tools and blades are sold separately and they each have an OFFSET dimension. When combined they equal the effective counterbore diameter. Choose the tool closest to the bore diameter, then choose the proper blade for the required counterbore diameter. There are 36 different size carbide blades that can fit their corresponding tool holder series.

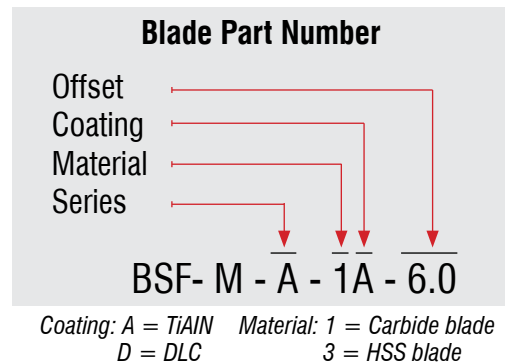
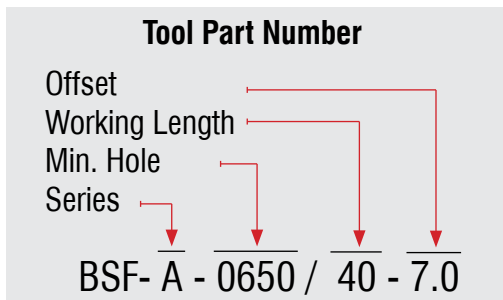

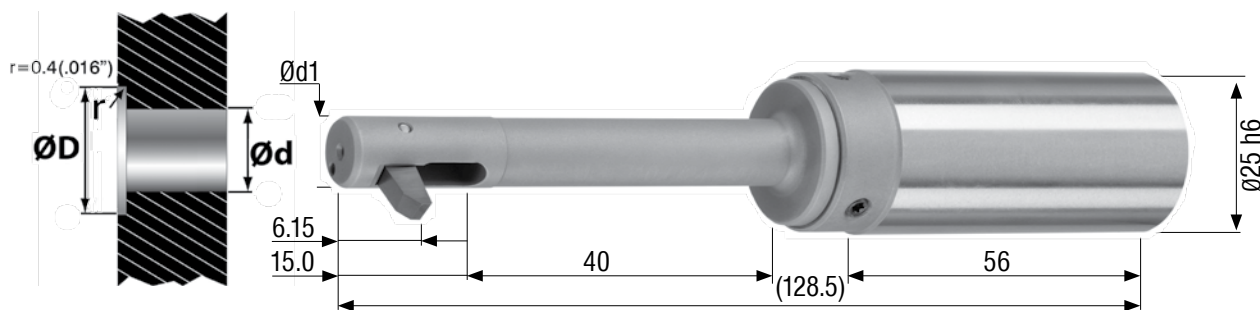

Minimum Hole $\varnothing d$	Tool Series A				
	$\varnothing d1$	C'Bore $\varnothing D$	Tool Order #	Blade Order #	
6.5 0.256	6.4 0.252	9.50 0.374	BSF-A-0650/040-6.5	BSF-M-A-1A-3.0	
		10.00 0.394	BSF-A-0650/040-7.0		
		10.50 0.413	BSF-A-0650/040-7.5		
		11.00 0.433	BSF-A-0650/040-6.5	BSF-M-A-1A-4.5	
		11.50 0.453	BSF-A-0650/040-7.0		
		12.00 0.472	BSF-A-0650/040-7.5	BSF-M-A-1A-6.0	
		12.50 0.492	BSF-A-0650/040-6.5		
		13.00 0.512	BSF-A-0650/040-7.0		
		13.50 0.531	BSF-A-0650/040-7.5		
		14.00 0.551	BSF-A-0650/040-6.5	BSF-M-A-1A-7.5	
	14.50 0.571	BSF-A-0650/040-7.0			
	15.00 0.591	BSF-A-0650/040-7.5			
7.0 0.276	6.9 0.272	10.50 0.413	BSF-A-0700/040-7.5	BSF-M-A-1A-3.0	
		11.00 0.433	BSF-A-0700/040-8.0		
			11.50 0.453	BSF-A-0700/040-7.0	BSF-M-A-1A-4.5
			12.00 0.472	BSF-A-0700/040-7.5	
			12.50 0.492	BSF-A-0700/040-8.0	
			13.00 0.512	BSF-A-0700/040-7.0	BSF-M-A-1A-6.0
			13.50 0.531	BSF-A-0700/040-7.5	
			14.00 0.551	BSF-A-0700/040-8.0	
			14.50 0.571	BSF-A-0700/040-7.0	
			15.00 0.591	BSF-A-0700/040-7.5	BSF-M-A-1A-7.5
	15.50 0.610	BSF-A-0700/040-8.0			
	16.00 0.630	BSF-A-0700/040-7.0			
	16.50 0.650	BSF-A-0700/040-7.5	BSF-M-A-1A-9.0		

*Other blade options available

Order Instructions:

Refer to page 162
"How to Order"
for order
instructions and
example

Special Application?

Submit the Application
Data Sheet on [Page 214](#)
to Heule Tool with your
application information
for our engineering team
to review.

Submit to:
info@heuletool.com

HOUSING
OPTIONS **PG. 189-190**

SPARE
PARTS **PG. 188**

PROGRAMMING **PG. 192-193**

CHANGE
BLADES **PG. 194**

HTC015

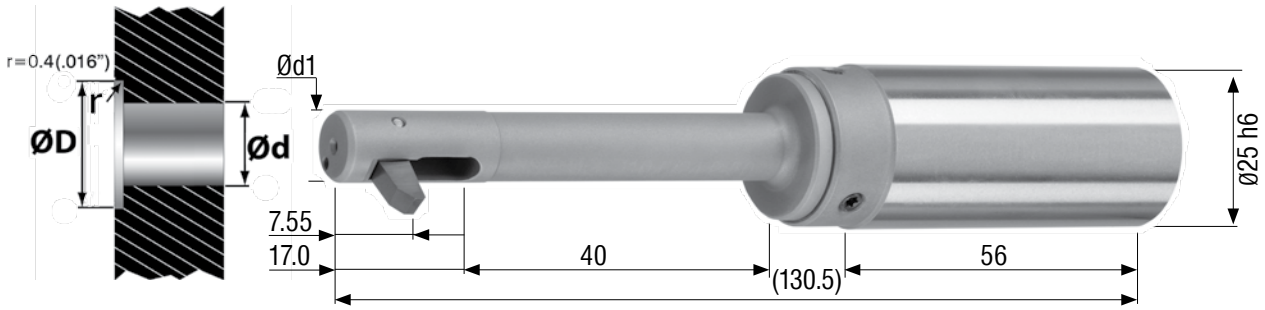

Minimum Hole $\varnothing d$	Tool Series B					
	$\varnothing d1$	C'Bore $\varnothing D$	Tool Order #	Blade Order #		
mm inches	mm inches	mm inches		Carbide, TiAlN*		
7.5 0.295	7.4 0.291	11.0 0.433	BSF-B-0750/040-7.5	BSF-M-B-1A-3.5		
		11.5 0.453	BSF-B-0750/040-8.0			
		12.0 0.472	BSF-B-0750/040-8.5			
				12.5 0.492	BSF-B-0750/040-7.5	BSF-M-B-1A-5.0
				13.0 0.512	BSF-B-0750/040-8.0	
				13.5 0.531	BSF-B-0750/040-8.5	
				14.0 0.551	BSF-B-0750/040-7.5	BSF-M-B-1A-6.5
				14.5 0.571	BSF-B-0750/040-8.0	
				15.0 0.591	BSF-B-0750/040-8.5	
				15.5 0.610	BSF-B-0750/040-7.5	BSF-M-B-1A-8.0
				16.0 0.630	BSF-B-0750/040-8.0	
				16.5 0.650	BSF-B-0750/040-8.5	
				17.0 0.669	BSF-B-0750/040-7.5	BSF-M-B-1A-9.5
				17.5 0.689	BSF-B-0750/040-8.0	
				18.0 0.709	BSF-B-0750/040-8.5	
8.0 0.315	7.9 0.311	12.0 0.472	BSF-B-0800/040-8.5	BSF-M-B-1A-3.5		
		12.5 0.492	BSF-B-0800/040-9.0			
		13.0 0.512	BSF-B-0800/040-8.0		BSF-M-B-1A-5.0	
		13.5 0.531	BSF-B-0800/040-8.5			
		14.0 0.551	BSF-B-0800/040-9.0			
				14.5 0.571	BSF-B-0800/040-8.0	BSF-M-B-1A-6.5
				15.0 0.591	BSF-B-0800/040-8.5	
				15.5 0.610	BSF-B-0800/040-9.0	
				16.0 0.630	BSF-B-0800/040-8.0	BSF-M-B-1A-8.0
				16.5 0.650	BSF-B-0800/040-8.5	
				17.0 0.669	BSF-B-0800/040-9.0	
				17.5 0.689	BSF-B-0800/040-8.0	BSF-M-B-1A-9.5
		18.0 0.709	BSF-B-0800/040-8.5			
		18.5 0.728	BSF-B-0800/040-9.0			

*Other blade options available

Order Instructions:
Refer to page 162
"How to Order"
for order
instructions and
example

Special Application?
Submit the Application
Data Sheet on [Page 214](#)
to Heule Tool with your
application information
for our engineering
team to review.

Submit to:
info@heuletool.com

HOUSING
OPTIONS **PG. 189-190**

SPARE
PARTS **PG. 188**

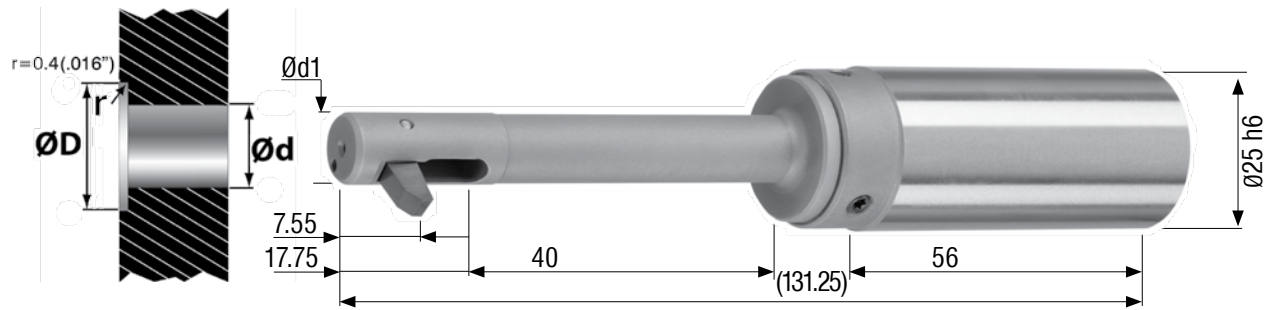

Minimum Hole $\varnothing d$	Tool Series B			
	$\varnothing d1$	C'Bore $\varnothing D$	Tool Order #	Blade Order #
mm inches	mm inches	mm inches		Carbide, TiAlN*
8.5 0.335	8.4 0.331	12.5 0.492	BSF-B-0850/040-9.0	BSF-M-B-1A-3.5
		13.0 0.512	BSF-B-0850/040-9.5	
		13.5 0.531	BSF-B-0850/040-8.5	BSF-M-B-1A-5.0
		14.0 0.551	BSF-B-0850/040-9.0	
		14.5 0.571	BSF-B-0850/040-9.5	
		15.0 0.591	BSF-B-0850/040-8.5	
		15.5 0.610	BSF-B-0850/040-9.0	BSF-M-B-1A-6.5
		16.0 0.630	BSF-B-0850/040-9.5	
		16.5 0.650	BSF-B-0850/040-8.5	BSF-M-B-1A-8.0
		17.0 0.669	BSF-B-0850/040-9.0	
		17.5 0.689	BSF-B-0850/040-9.5	
		18.0 0.709	BSF-B-0850/040-8.5	
		18.5 0.728	BSF-B-0850/040-9.0	BSF-M-B-1A-9.5
		19.0 0.748	BSF-B-0850/040-9.5	
		19.5 0.768	BSF-B-0850/040-8.5	BSF-M-B-1A-11.0
		20.0 0.787	BSF-B-0850/040-9.0	

*Other blade options available

Order Instructions:
Refer to page 162
"How to Order"
for order
instructions and
example

Special Application?
Submit the Application
Data Sheet on [Page 214](#)
to Heule Tool with your
application information
for our engineering team
to review.

Submit to:
info@heuletool.com

PROGRAMMING **PG. 192-193**

CHANGE BLADES **PG. 194**

HTC015

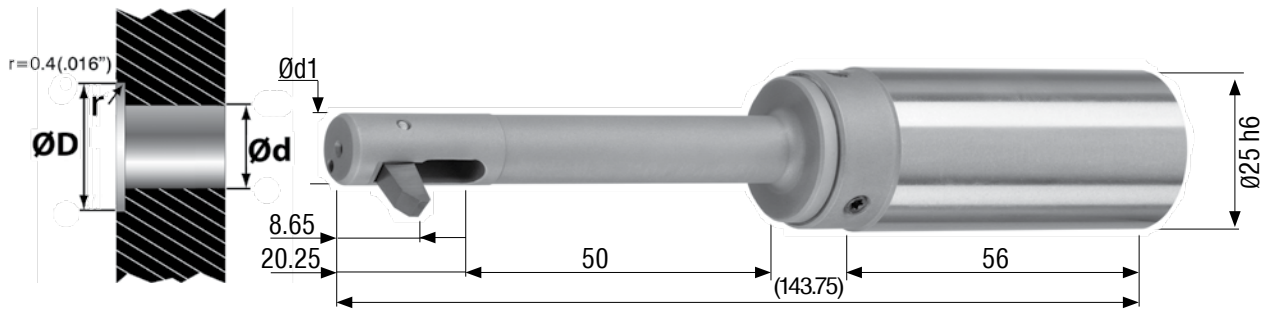

Minimum Hole $\varnothing d$	Tool Series C			
	$\varnothing d1$	C'Bore $\varnothing D$	Tool Order #	Blade Order #
mm inches	mm inches	mm inches		Carbide, TiAlN*
9.0 0.354	8.9 0.350	13.5 0.531	BSF-C-0900/050-9.5	BSF-M-C-1A-4.0
		14.0 0.551	BSF-C-0900/050-10.0	
		14.5 0.571	BSF-C-0900/050-10.5	
		15.0 0.591	BSF-C-0900/050-9.5	BSF-M-C-1A-5.5
		15.5 0.610	BSF-C-0900/050-10.0	
		16.0 0.630	BSF-C-0900/050-10.5	
		16.5 0.650	BSF-C-0900/050-9.5	BSF-M-C-1A-7.0
		17.0 0.669	BSF-C-0900/050-10.0	
		17.5 0.689	BSF-C-0900/050-10.5	
		18.0 0.709	BSF-C-0900/050-9.5	BSF-M-C-1A-8.5
9.5 0.374	9.4 0.370	18.5 0.728	BSF-C-0900/050-10.0	
		19.0 0.748	BSF-C-0900/050-10.5	
		19.5 0.768	BSF-C-0900/050-9.5	BSF-M-C-1A-10.0
		20.0 0.787	BSF-C-0900/050-10.0	
		20.5 0.807	BSF-C-0900/050-10.5	
		21.0 0.827	BSF-C-0900/050-9.5	BSF-M-C-1A-11.5
		14.5 0.571	BSF-C-0950/050-10.5	BSF-M-C-1A-4.0
		15.0 0.591	BSF-C-0950/050-11.0	
		15.5 0.610	BSF-C-0950/050-10.0	BSF-M-C-1A-5.5
		16.0 0.630	BSF-C-0950/050-10.5	
16.5 0.650	BSF-C-0950/050-11.0			
17.0 0.669	BSF-C-0950/050-10.0	BSF-M-C-1A-7.0		
17.5 0.689	BSF-C-0950/050-10.5			
18.0 0.709	BSF-C-0950/050-11.0			
18.5 0.728	BSF-C-0950/050-10.0	BSF-M-C-1A-8.5		
19.0 0.748	BSF-C-0950/050-10.5			
19.5 0.768	BSF-C-0950/050-11.0			
20.0 0.787	BSF-C-0950/050-10.0	BSF-M-C-1A-10.0		
20.5 0.807	BSF-C-0950/050-10.5			
21.0 0.827	BSF-C-0950/050-11.0			
21.5 0.846	BSF-C-0950/050-10.0	BSF-M-C-1A-11.5		
22.0 0.866	BSF-C-0950/050-10.5			

*Other blade options available

Order Instructions:

Refer to page 162
"How to Order"
for order
instructions and
example

Special Application?

Submit the Application
Data Sheet on [Page 214](#)
to Heule Tool with your
application information
for our engineering
team to review.

Submit to:
info@heuletool.com

HOUSING
OPTIONS PG.
189-190

SPARE
PARTS PG.
188

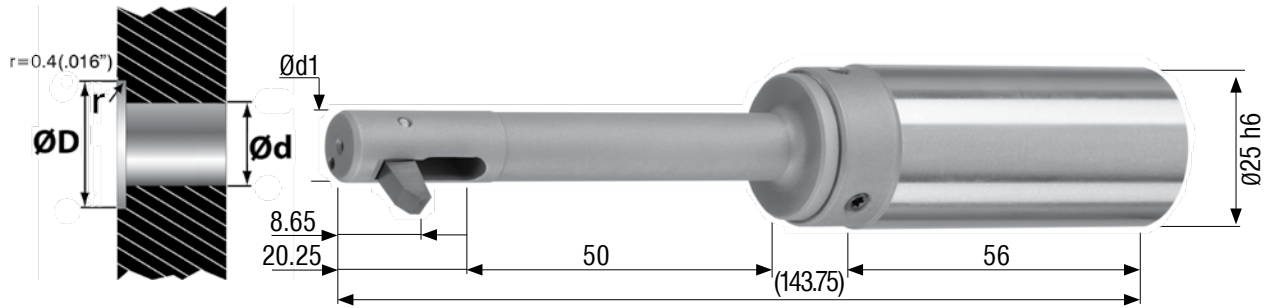

Minimum Hole $\varnothing d$	Tool Series C			
	$\varnothing d1$	C'Bore $\varnothing D$	Tool Order #	Blade Order #
mm inches	mm inches	mm inches		Carbide, TiAlN*
10.0 0.394	9.9 0.390	15.0 0.591	BSF-C-1000/050-11.0	BSF-M-C-1A-4.0
		15.5 0.610	BSF-C-1000/050-11.5	
		16.0 0.630	BSF-C-1000/050-10.5	BSF-M-C-1A-5.5
		16.5 0.650	BSF-C-1000/050-11.0	
		17.0 0.669	BSF-C-1000/050-11.5	
		17.5 0.689	BSF-C-1000/050-10.5	
		18.0 0.709	BSF-C-1000/050-11.0	
		18.5 0.728	BSF-C-1000/050-11.5	BSF-M-C-1A-7.0
		19.0 0.748	BSF-C-1000/050-10.5	
		19.5 0.768	BSF-C-1000/050-11.0	
		20.0 0.787	BSF-C-1000/050-11.5	BSF-M-C-1A-8.5
		20.5 0.807	BSF-C-1000/050-10.5	
		21.0 0.827	BSF-C-1000/050-11.0	
		21.5 0.846	BSF-C-1000/050-11.5	BSF-M-C-1A-10.0
		22.0 0.866	BSF-C-1000/050-10.5	
		22.5 0.886	BSF-C-1000/050-11.0	
		23.0 0.906	BSF-C-1000/050-11.5	BSF-M-C-1A-11.5

*Other blade options available

Order Instructions:

Refer to page 162
"How to Order"
for order
instructions and
example

Special Application?

Submit the Application
Data Sheet on **Page 214**
to Heule Tool with your
application information
for our engineering team
to review.

Submit to:
info@heuletool.com

PROGRAMMING **PG. 192-193**

CHANGE BLADES **PG. 194**

HTC015

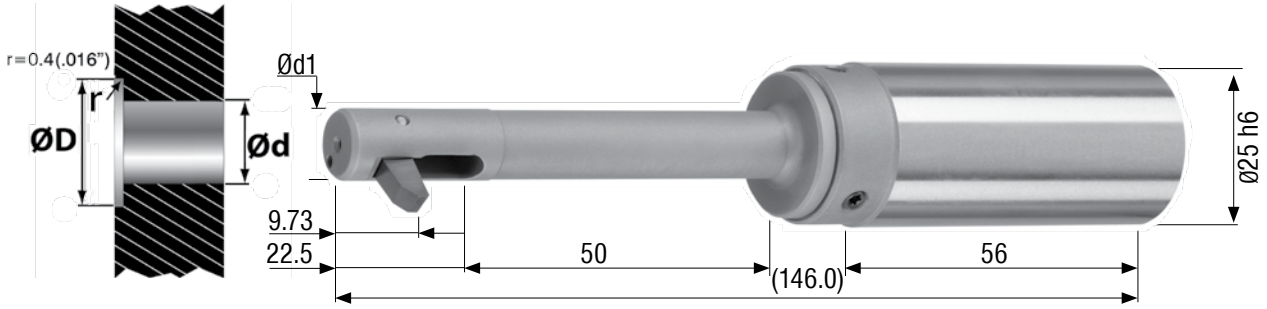

Minimum Hole $\varnothing d$	Tool Series D			
	$\varnothing d1$	C'Bore $\varnothing D$	Tool Order #	Blade Order #
mm inches	mm inches	mm inches		Carbide, TiAlN*
10.5 0.413	10.4 0.409	16.0 0.630	BSF-D-1050/050-11.5	BSF-M-D-1A-4.5
		16.5 0.650	BSF-D-1050/050-12.0	
		17.0 0.669	BSF-D-1050/050-12.5	
		17.5 0.689	BSF-D-1050/050-13.0	
		18.0 0.709	BSF-D-1050/050-11.0	BSF-M-D-1A-7.0
		18.5 0.728	BSF-D-1050/050-11.5	
		19.0 0.748	BSF-D-1050/050-12.0	
		19.5 0.768	BSF-D-1050/050-12.5	
		20.0 0.787	BSF-D-1050/050-13.0	
		20.5 0.807	BSF-D-1050/050-11.0	
21.0 0.827	BSF-D-1050/050-11.5			
21.5 0.846	BSF-D-1050/050-12.0			
22.0 0.866	BSF-D-1050/050-12.5			
		22.5 0.886	BSF-D-1050/050-13.0	BSF-M-D-1A-12.0
		23.0 0.906	BSF-D-1050/050-11.0	
		23.5 0.925	BSF-D-1050/050-11.5	
		24.0 0.945	BSF-D-1050/050-12.0	
		24.5 0.965	BSF-D-1050/050-12.5	
		25.0 0.984	BSF-D-1050/050-13.0	

*Other blade options available

Order Instructions:

Refer to page 162
"How to Order"
for order
instructions and
example

Special Application?

Submit the Application
Data Sheet on [Page 214](#)
to Heule Tool with your
application information
for our engineering
team to review.

Submit to:
info@heuletool.com

HOUSING
OPTIONS **PG. 189-190**

SPARE
PARTS **PG. 188**

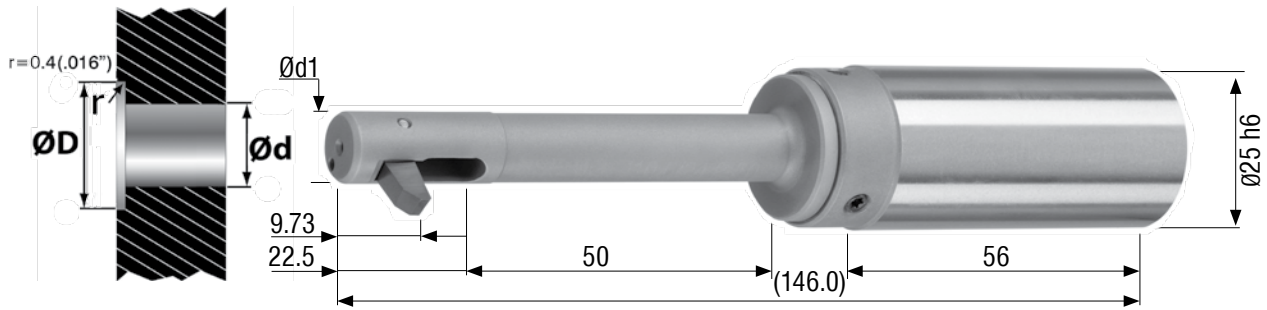

Minimum Hole $\varnothing d$	Tool Series D						
	$\varnothing d1$	C'Bore $\varnothing D$	Tool Order #	Blade Order #			
mm inches	mm inches	mm inches		Carbide, TiAlN*			
11.0 0.433	10.9 0.429	16.5 0.650	BSF-D-1100/050-12.0	BSF-M-D-1A-4.5			
		17.0 0.669	BSF-D-1100/050-12.5				
		17.5 0.689	BSF-D-1100/050-13.0				
				18.0 0.709	BSF-D-1100/050-13.5	BSF-M-D-1A-7.0	
				18.5 0.728	BSF-D-1100/050-11.5		
				19.0 0.748	BSF-D-1100/050-12.0		
				19.5 0.768	BSF-D-1100/050-12.5		
				20.0 0.787	BSF-D-1100/050-13.0		
20.5 0.807	BSF-D-1100/050-13.5						
				21.0 0.827	BSF-D-1100/050-11.5		BSF-M-D-1A-9.5
		21.5 0.846	BSF-D-1100/050-12.0				
		22.0 0.866	BSF-D-1100/050-12.5				
		22.5 0.886	BSF-D-1100/050-13.0				
		23.0 0.906	BSF-D-1100/050-13.5				
				23.5 0.925	BSF-D-1100/050-11.5	BSF-M-D-1A-12.0	
				24.0 0.945	BSF-D-1100/050-12.0		
				24.5 0.965	BSF-D-1100/050-12.5		
25.0 0.984	BSF-D-1100/050-13.0						
25.5 1.004	BSF-D-1100/050-13.5						

*Other blade options available

Order Instructions:

Refer to page 162
"How to Order"
for order
instructions and
example

Special Application?

Submit the Application
Data Sheet on [Page 214](#)
to Heule Tool with your
application information
for our engineering team
to review.

Submit to:
info@heuletool.com

PROGRAMMING PG. 192-193

CHANGE BLADES PG. 194

HTC015

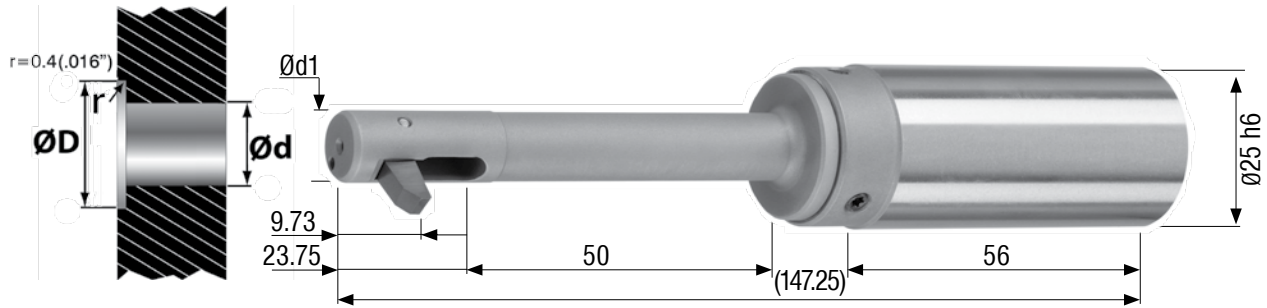

Minimum Hole $\varnothing d$	Tool Series D			
	$\varnothing d1$	C'Bore $\varnothing D$	Tool Order #	Blade Order #
mm inches	mm inches	mm inches		Carbide, TiAlN*
11.5 0.453	11.4 0.449	17.5 0.689	BSF-D-1150/050-13.0	BSF-M-D-1A-4.5
		18.0 0.709	BSF-D-1150/050-13.5	
		18.5 0.728	BSF-D-1150/050-14.0	
		19.0 0.748	BSF-D-1150/050-12.0	
		19.5 0.768	BSF-D-1150/050-12.5	
		20.0 0.787	BSF-D-1150/050-13.0	
		20.5 0.807	BSF-D-1150/050-13.5	
		21.0 0.827	BSF-D-1150/050-14.0	BSF-M-D-1A-7.0
		21.5 0.846	BSF-D-1150/050-12.0	
		22.0 0.866	BSF-D-1150/050-12.5	
		22.5 0.886	BSF-D-1150/050-13.0	
		23.0 0.906	BSF-D-1150/050-13.5	
		23.5 0.925	BSF-D-1150/050-14.0	
		24.0 0.945	BSF-D-1150/050-12.0	
		24.5 0.965	BSF-D-1150/050-12.5	BSF-M-D-1A-12.0
		25.0 0.984	BSF-D-1150/050-13.0	
		25.5 1.004	BSF-D-1150/050-13.5	
		26.0 1.024	BSF-D-1150/050-14.0	
		26.5 1.043	BSF-D-1150/050-12.0	

*Other blade options available

Order Instructions:

Refer to page 162
"How to Order"
for order
instructions and
example

Special Application?

Submit the Application
Data Sheet on [Page 214](#)
to Heule Tool with your
application information
for our engineering
team to review.

Submit to:
info@heuletool.com

HOUSING
OPTIONS **PG. 189-190**

SPARE
PARTS **PG. 188**

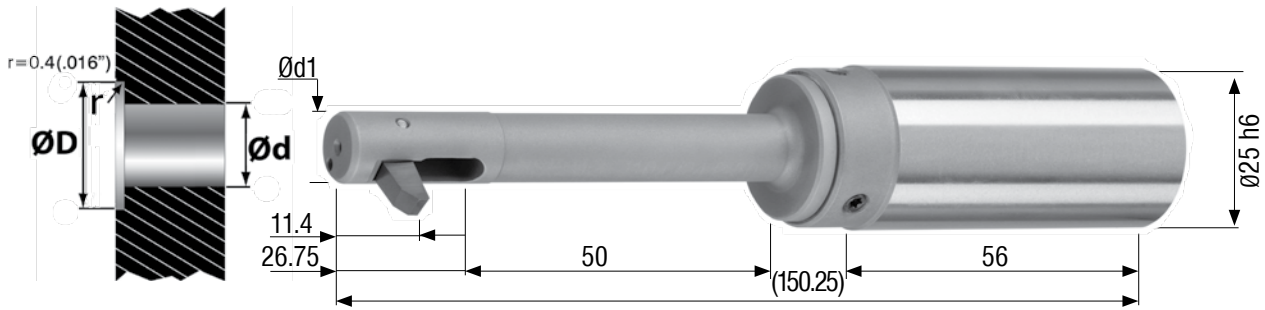

Minimum Hole \varnothing	Tool Series E				
	$\varnothing d1$	C'Bore	Tool Order #	Blade Order #	
mm inches	mm inches	mm inches		Carbide, TiAlN*	
12.0 0.472	11.9 0.469	18.0 0.709	BSF-E-1200/050-13.0	BSF-M-E-1A-5.0	
		18.5 0.728	BSF-E-1200/050-13.5		
		19.0 0.748	BSF-E-1200/050-14.0		
		19.5 0.768	BSF-E-1200/050-14.5		
		20.0 0.787	BSF-E-1200/050-15.0		
		20.5 0.807	BSF-E-1200/050-13.0	BSF-M-E-1A-7.5	
		21.0 0.827	BSF-E-1200/050-13.5		
		21.5 0.846	BSF-E-1200/050-14.0		
		22.0 0.866	BSF-E-1200/050-14.5		
		22.5 0.886	BSF-E-1200/050-15.0		
		23.0 0.906	BSF-E-1200/050-13.0		BSF-M-E-1A-10.0
		23.5 0.925	BSF-E-1200/050-13.5		
		24.0 0.945	BSF-E-1200/050-14.0	BSF-M-E-1A-12.5	
		24.5 0.965	BSF-E-1200/050-14.5		
		25.0 0.984	BSF-E-1200/050-15.0		
		25.5 1.004	BSF-E-1200/050-13.0		
		26.0 1.024	BSF-E-1200/050-13.5		
		26.5 1.043	BSF-E-1200/050-14.0		
		27.0 1.063	BSF-E-1200/050-14.5		
		27.5 1.083	BSF-E-1200/050-15.0	BSF-M-E-1A-15.0	
		28.0 1.102	BSF-E-1200/050-13.0		

*Other blade options available

Order Instructions:

Refer to page 162
"How to Order"
for order
instructions and
example

Special Application?

Submit the Application
Data Sheet on **Page 214**
to Heule Tool with your
application information
for our engineering team
to review.

Submit to:
info@heuletool.com

PROGRAMMING PG. 192-193

CHANGE BLADES PG. 194

HTC015

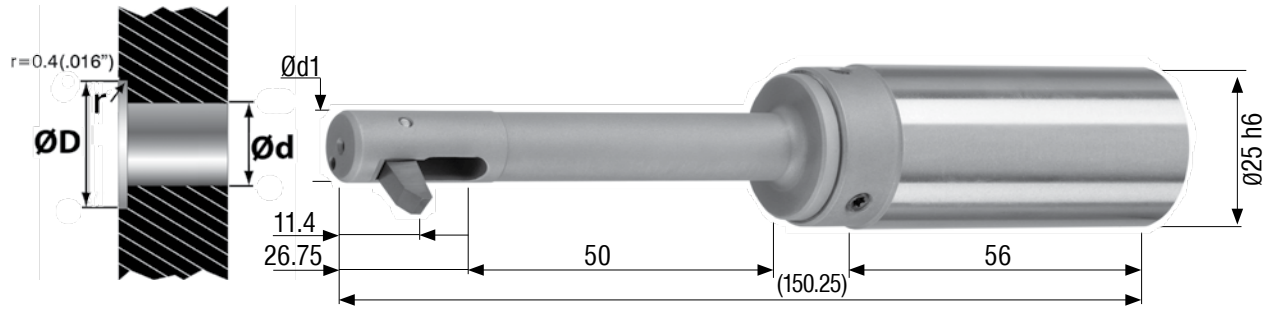

Minimum Hole $\varnothing d$	Tool Series E				
	$\varnothing d1$	C'Bore $\varnothing D$	Tool Order #	Blade Order #	
mm inches	mm inches	mm inches		Carbide, TiAlN*	
12.5 0.492	12.4 0.488	19.0 0.748	BSF-E-1250/050-14.0	BSF-M-E-1A-5.0	
		19.5 0.768	BSF-E-1250/050-14.5		
		20.0 0.787	BSF-E-1250/050-15.0		
		20.5 0.807	BSF-E-1250/050-15.5	BSF-M-E-1A-7.5	
		21.0 0.827	BSF-E-1250/050-13.5		
		21.5 0.846	BSF-E-1250/050-14.0		
		22.0 0.866	BSF-E-1250/050-14.5		
		22.5 0.886	BSF-E-1250/050-15.0		
		23.0 0.906	BSF-E-1250/050-15.5		
		23.5 0.925	BSF-E-1250/050-13.5	BSF-M-E-1A-10.0	
		24.0 0.945	BSF-E-1250/050-14.0		
		24.5 0.965	BSF-E-1250/050-14.5		
		25.0 0.984	BSF-E-1250/050-15.0		
		25.5 1.004	BSF-E-1250/050-15.5		
		26.0 1.024	BSF-E-1250/050-13.5		BSF-M-E-1A-12.5
		26.5 1.043	BSF-E-1250/050-14.0		
		27.0 1.063	BSF-E-1250/050-14.5	BSF-M-E-1A-15.0	
		27.5 1.083	BSF-E-1250/050-15.0		
		28.0 1.102	BSF-E-1250/050-15.5		
		28.5 1.122	BSF-E-1250/050-13.5		
		29.0 1.142	BSF-E-1250/050-14.0		

*Other blade options available

Order Instructions:

Refer to page 162
"How to Order"
for order
instructions and
example

Special Application?

Submit the Application
Data Sheet on [Page 214](#)
to Heule Tool with your
application information
for our engineering
team to review.

Submit to:
info@heuletool.com

HOUSING
OPTIONS **PG. 189-190**

SPARE
PARTS **PG. 188**

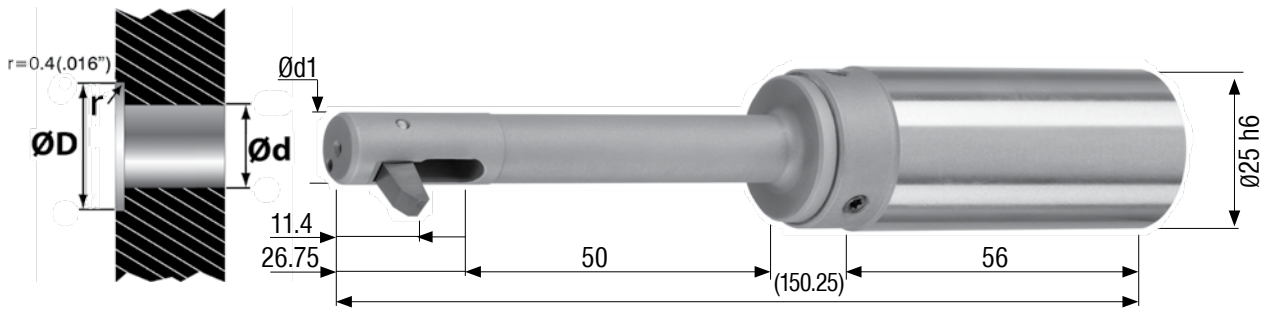

Minimum Hole $\varnothing d$	Tool Series E			
	$\varnothing d1$	C'Bore $\varnothing D$	Tool Order #	Blade Order #
mm inches	mm inches	mm inches		Carbide, TiAlN*
13.0 0.512	12.9 0.508	19.5 0.768	BSF-E-1300/050-14.5	BSF-M-E-1A-5.0
		20.0 0.787	BSF-E-1300/050-15.0	
		20.5 0.807	BSF-E-1300/050-15.5	
		21.0 0.827	BSF-E-1300/050-16.0	BSF-M-E-1A-7.5
		21.5 0.846	BSF-E-1300/050-14.0	
		22.0 0.866	BSF-E-1300/050-14.5	
		22.5 0.886	BSF-E-1300/050-15.0	
		23.0 0.906	BSF-E-1300/050-15.5	
		23.5 0.925	BSF-E-1300/050-16.0	
		24.0 0.945	BSF-E-1300/050-14.0	BSF-M-E-1A-10.0
		24.5 0.965	BSF-E-1300/050-14.5	
		25.0 0.984	BSF-E-1300/050-15.0	
		25.5 1.004	BSF-E-1300/050-15.5	
		26.0 1.024	BSF-E-1300/050-16.0	
		26.5 1.043	BSF-E-1300/050-14.0	
27.0 1.063	BSF-E-1300/050-14.5			
27.5 1.083	BSF-E-1300/050-15.0			
28.0 1.102	BSF-E-1300/050-15.5			
		28.5 1.122	BSF-E-1300/050-16.0	BSF-M-E-1A-15.0
		29.0 1.142	BSF-E-1300/050-14.0	
		29.5 1.161	BSF-E-1300/050-14.5	
		30.0 1.181	BSF-E-1300/050-15.0	

*Other blade options available

Order Instructions:
Refer to page 162
"How to Order"
for order
instructions and
example

Special Application?
Submit the Application
Data Sheet on [Page 214](#)
to Heule Tool with your
application information
for our engineering team
to review.

Submit to:
info@heuletool.com

PROGRAMMING PG. 192-193

CHANGE BLADES PG. 194

HTC015

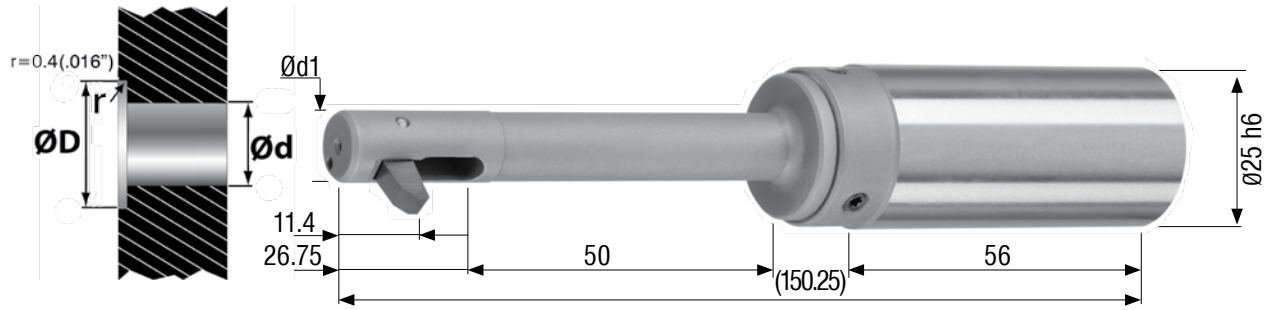

Minimum Hole $\varnothing d$	Tool Series E				
	$\varnothing d1$	C'Bore $\varnothing D$	Tool Order #	Blade Order #	
mm inches	mm inches	mm inches		Carbide, TiAlN*	
13.5 0.531	13.4 0.528	20.5 0.807	BSF-E-1350/050-15.5	BSF-M-E-1A-5.0	
		21.0 0.827	BSF-E-1350/050-16.0		
		21.5 0.846	BSF-E-1350/050-16.5		
		22.0 0.866	BSF-E-1350/050-14.5	BSF-M-E-1A-7.5	
		22.5 0.886	BSF-E-1350/050-15.0		
		23.0 0.906	BSF-E-1350/050-15.5		
		23.5 0.925	BSF-E-1350/050-16.0		
		24.0 0.945	BSF-E-1350/050-16.5		
		24.5 0.965	BSF-E-1350/050-14.5		BSF-M-E-1A-10.0
		25.0 0.984	BSF-E-1350/050-15.0		
		25.5 1.004	BSF-E-1350/050-15.5	BSF-M-E-1A-12.5	
		26.0 1.024	BSF-E-1350/050-16.0		
		26.5 1.043	BSF-E-1350/050-16.5		
		27.0 1.063	BSF-E-1350/050-14.5		
		27.5 1.083	BSF-E-1350/050-15.0		
		28.0 1.102	BSF-E-1350/050-15.5		
		28.5 1.122	BSF-E-1350/050-16.0		
		29.0 1.142	BSF-E-1350/050-16.5	BSF-M-E-1A-15.0	
		29.5 1.161	BSF-E-1350/050-14.5		
		30.0 1.181	BSF-E-1350/050-15.0		
		30.5 1.201	BSF-E-1350/050-15.5		
		31.0 1.220	BSF-E-1350/050-16.0		
		31.5 1.240	BSF-E-1350/050-16.5		

*Other blade options available

Order Instructions:

Refer to page 162
"How to Order"
for order
instructions and
example

Special Application?

Submit the Application
Data Sheet on [Page 214](#)
to Heule Tool with your
application information
for our engineering
team to review.

Submit to:
info@heuletool.com

HOUSING
OPTIONS **PG. 189-190**

SPARE
PARTS **PG. 188**

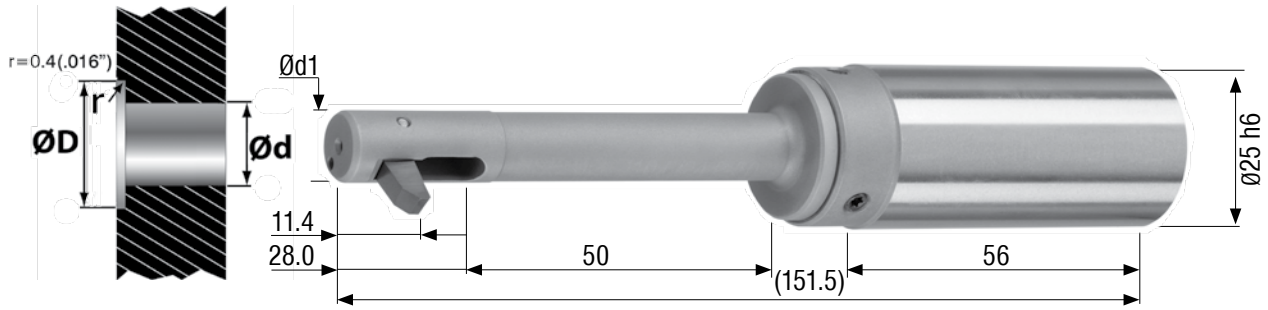

Minimum Hole $\varnothing d$	Tool Series E				
	$\varnothing d1$	C'Bore $\varnothing D$	Tool Order #	Blade Order #	
mm inches	mm inches	mm inches		Carbide, TiAlN*	
14.0 0.551	13.9 0.547	21.0 0.827	BSF-E-1400/050-16.0	BSF-M-E-1A-5.0	
		21.5 0.846	BSF-E-1400/050-16.5		
		22.0 0.866	BSF-E-1400/050-17.0		
		22.5 0.886	BSF-E-1400/050-15.0	BSF-M-E-1A-7.5	
		23.0 0.906	BSF-E-1400/050-15.5		
		23.5 0.925	BSF-E-1400/050-16.0		
		24.0 0.945	BSF-E-1400/050-16.5		
		24.5 0.965	BSF-E-1400/050-17.0		
		25.0 0.984	BSF-E-1400/050-15.0		BSF-M-E-1A-10.0
		25.5 1.004	BSF-E-1400/050-15.5		
		26.0 1.024	BSF-E-1400/050-16.0	BSF-M-E-1A-12.5	
		26.5 1.043	BSF-E-1400/050-16.5		
		27.0 1.063	BSF-E-1400/050-17.0		
		27.5 1.083	BSF-E-1400/050-15.0		
		28.0 1.102	BSF-E-1400/050-15.5		
		28.5 1.122	BSF-E-1400/050-16.0		
		29.0 1.142	BSF-E-1400/050-16.5		
		29.5 1.161	BSF-E-1400/050-17.0	BSF-M-E-1A-15.0	
		30.0 1.181	BSF-E-1400/050-15.0		
		30.5 1.201	BSF-E-1400/050-15.5		
		31.0 1.220	BSF-E-1400/050-16.0		
		31.5 1.240	BSF-E-1400/050-16.5		
		32.0 1.260	BSF-E-1400/050-17.0	BSF-M-E-1A-17.5	
		32.5 1.280	BSF-E-1400/050-15.0		

*Other blade options available

Order Instructions:
Refer to page 162
"How to Order"
for order
instructions and
example

Special Application?
Submit the Application
Data Sheet on [Page 214](#)
to Heule Tool with your
application information
for our engineering team
to review.

Submit to:
info@heuletool.com

PROGRAMMING PG. 192-193

CHANGE BLADES PG. 194

HTC015

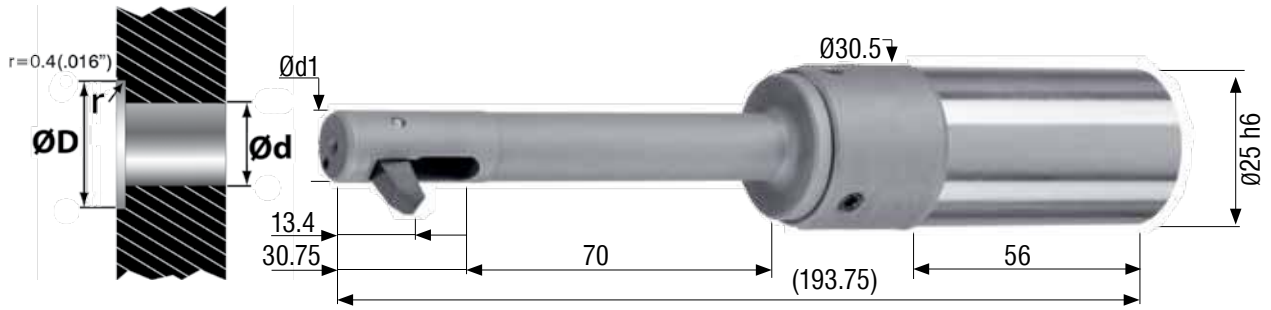

Minimum Hole $\varnothing d$	Tool Series F				
	$\varnothing d1$	C'Bore $\varnothing D$	Tool Order #	Blade Order #	
mm inches	mm inches	mm inches		Carbide, TiAlN*	
14.5 0.571	14.4 0.567	22.0 0.866	BSF-F-1450/070-16.5	BSF-M-F-1A-5.5	
		22.5 0.886	BSF-F-1450/070-17.0		
		23.0 0.906	BSF-F-1450/070-17.5		
		23.5 0.925	BSF-F-1450/070-18.0		
		24.0 0.945	BSF-F-1450/070-18.5		
		24.5 0.965	BSF-F-1450/070-19.0		
		25.0 0.984	BSF-F-1450/070-16.0	BSF-M-F-1A-9.0	
		25.5 1.004	BSF-F-1450/070-16.5		
		26.0 1.024	BSF-F-1450/070-17.0		
		26.5 1.043	BSF-F-1450/070-17.5		
		27.0 1.063	BSF-F-1450/070-18.0		
		27.5 1.083	BSF-F-1450/070-18.5		
		28.0 1.102	BSF-F-1450/070-19.0		
		28.5 1.122	BSF-F-1450/070-16.0		BSF-M-F-1A-12.5
		29.0 1.142	BSF-F-1450/070-16.5		
		29.5 1.161	BSF-F-1450/070-17.0		
30.0 1.181	BSF-F-1450/070-17.5				
		30.5 1.201	BSF-F-1450/070-18.0	BSF-M-F-1A-16.0	
		31.0 1.220	BSF-F-1450/070-18.5		
		31.5 1.240	BSF-F-1450/070-19.0		
		32.0 1.260	BSF-F-1450/070-16.0		
		32.5 1.280	BSF-F-1450/070-16.5		
		33.0 1.299	BSF-F-1450/070-17.0		
		33.5 1.319	BSF-F-1450/070-17.5		

*Other blade options available

Order Instructions:

Refer to page 162
"How to Order"
for order
instructions and
example

Special Application?

Submit the Application
Data Sheet on [Page 214](#)
to Heule Tool with your
application information
for our engineering
team to review.

Submit to:
info@heuletool.com

HOUSING
OPTIONS **PG. 189-190**

SPARE
PARTS **PG. 188**

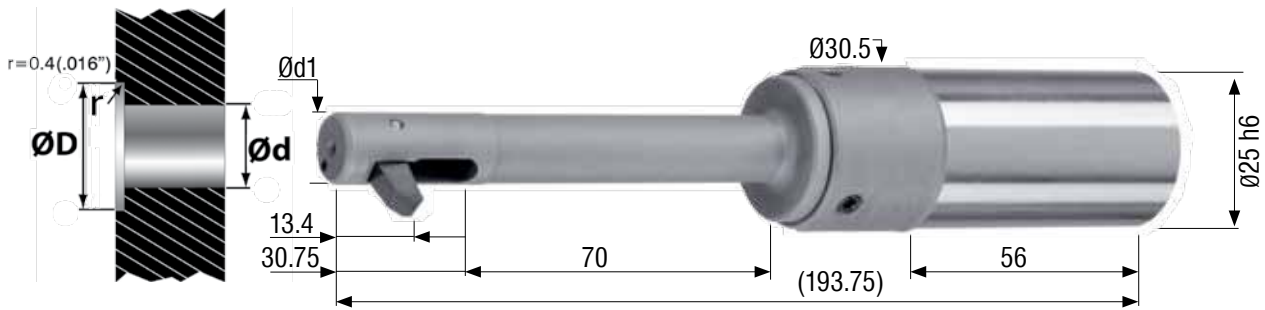

Minimum Hole $\varnothing d$	Tool Series F				
	$\varnothing d1$	C'Bore $\varnothing D$	Tool Order #	Blade Order #	
mm inches	mm inches	mm inches		Carbide, TiAlN*	
15.0 0.591	14.9 0.587	22.5 0.886	BSF-F-1500/070-17.0	BSF-M-F-1A-5.5	
		23.0 0.906	BSF-F-1500/070-17.5		
		23.5 0.925	BSF-F-1500/070-18.0		
		24.0 0.945	BSF-F-1500/070-18.5		
		24.5 0.965	BSF-F-1500/070-19.0		
		25.0 0.984	BSF-F-1500/070-19.5		
		25.5 1.004	BSF-F-1500/070-16.5		BSF-M-F-1A-9.0
		26.0 1.024	BSF-F-1500/070-17.0		
		26.5 1.043	BSF-F-1500/070-17.5		
		27.0 1.063	BSF-F-1500/070-18.0		
		27.5 1.083	BSF-F-1500/070-18.5		
		28.0 1.102	BSF-F-1500/070-19.0		
		28.5 1.122	BSF-F-1500/070-19.5		
		29.0 1.142	29.0 1.142		29.0 1.142
29.5 1.161	BSF-F-1500/070-17.0				
30.0 1.181	BSF-F-1500/070-17.5				
30.5 1.201	BSF-F-1500/070-18.0				
31.0 1.220	BSF-F-1500/070-18.5				
31.5 1.240	BSF-F-1500/070-19.0				
32.0 1.260	BSF-F-1500/070-19.5				
32.5 1.280	BSF-F-1500/070-16.5			BSF-M-F-1A-16.0	
33.0 1.299	BSF-F-1500/070-17.0				
33.5 1.319	BSF-F-1500/070-17.5				
34.0 1.339	BSF-F-1500/070-18.0				
34.5 1.358	BSF-F-1500/070-18.5				

Order Instructions:

Refer to page 162
"How to Order"
for order
instructions and
example

Special Application?

Submit the Application
Data Sheet on **Page 214**
to Heule Tool with your
application information
for our engineering team
to review.

Submit to:
info@heuletool.com

PROGRAMMING PG. 192-193

CHANGE BLADES PG. 194

HTC015

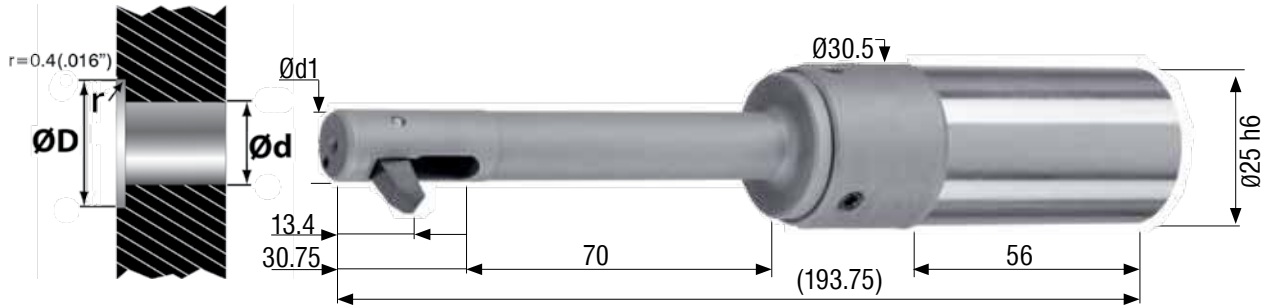

Minimum Hole $\varnothing d$	Tool Series F				
	$\varnothing d1$	C'Bore $\varnothing D$	Tool Order #	Blade Order #	
mm inches	mm inches	mm inches		Carbide, TiAlN*	
15.5 0.610	15.4 0.606	23.5 0.925	BSF-F-1550/070-18.0	BSF-M-F-1A-5.5	
		24.0 0.945	BSF-F-1550/070-18.5		
		24.5 0.965	BSF-F-1550/070-19.0		
		25.0 0.984	BSF-F-1550/070-19.5		
		25.5 1.004	BSF-F-1550/070-20.0		
		26.0 1.024	BSF-F-1550/070-17.0	BSF-M-F-1A-9.0	
		26.5 1.043	BSF-F-1550/070-17.5		
		27.0 1.063	BSF-F-1550/070-18.0		
		27.5 1.083	BSF-F-1550/070-18.5		
		28.0 1.102	BSF-F-1550/070-19.0		
		28.5 1.122	BSF-F-1550/070-19.5		
		29.0 1.142	BSF-F-1550/070-20.0		
		29.5 1.161	BSF-F-1550/070-17.0		BSF-M-F-1A-12.5
		30.0 1.181	BSF-F-1550/070-17.5		
		30.5 1.201	BSF-F-1550/070-18.0		
31.0 1.220	BSF-F-1550/070-18.5				
31.5 1.240	BSF-F-1550/070-19.0				
		32.0 1.260	BSF-F-1550/070-19.5	BSF-M-F-1A-16.0	
		32.5 1.280	BSF-F-1550/070-20.0		
		33.0 1.299	BSF-F-1550/070-17.0		
		33.5 1.319	BSF-F-1550/070-17.5		
		34.0 1.339	BSF-F-1550/070-18.0		
		34.5 1.358	BSF-F-1550/070-18.5		
		35.0 1.378	BSF-F-1550/070-19.0		
35.5 1.398	BSF-F-1550/070-19.5				
36.0 1.417	BSF-F-1550/070-20.0				

Order Instructions:

Refer to page 162
"How to Order"
for order
instructions and
example

Special Application?

Submit the Application
Data Sheet on **Page 214**
to Heule Tool with your
application information
for our engineering
team to review.

Submit to:
info@heuletool.com

*Other blade options available

HOUSING
OPTIONS **PG. 189-190**

SPARE
PARTS **PG. 188**

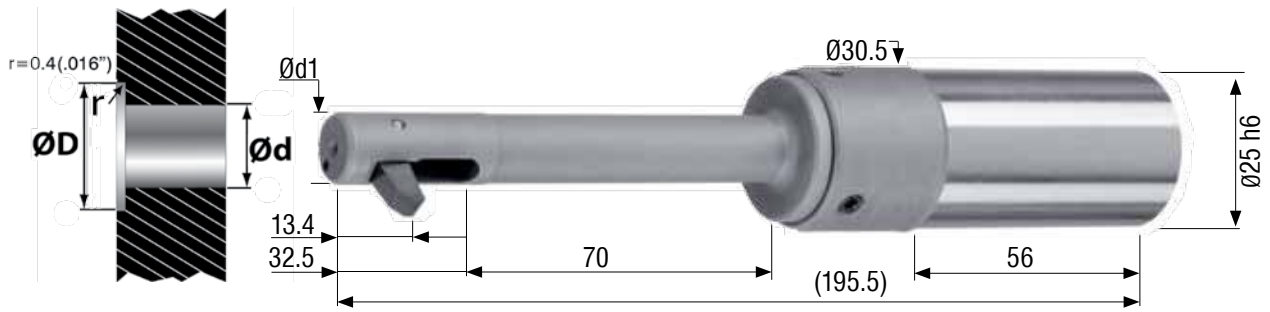

Minimum Hole Ød	Tool Series F				
	Ød1	C'Bore ØD	Tool Order #	Blade Order #	
mm inches	mm inches	mm inches		Carbide, TiAlN*	
16.0 0.630	15.9 0.626	24.0 0.945	BSF-F-1600/070-18.5	BSF-M-F-1A-5.5	
		24.5 0.965	BSF-F-1600/070-19.0		
		25.0 0.984	BSF-F-1600/070-19.5		
		25.5 1.004	BSF-F-1600/070-20.0		
		26.0 1.024	BSF-F-1600/070-20.5		
		26.5 1.043	BSF-F-1600/070-17.5		BSF-M-F-1A-9.0
		27.0 1.063	BSF-F-1600/070-18.0		
		27.5 1.083	BSF-F-1600/070-18.5		
		28.0 1.102	BSF-F-1600/070-19.0		
		28.5 1.122	BSF-F-1600/070-19.5		
		29.0 1.142	BSF-F-1600/070-20.0	BSF-M-F-1A-12.5	
		29.5 1.161	BSF-F-1600/070-20.5		
		30.0 1.181	BSF-F-1600/070-17.5		
		30.5 1.201	BSF-F-1600/070-18.0		
		31.0 1.220	BSF-F-1600/070-18.5		
		31.5 1.240	BSF-F-1600/070-19.0		
		32.0 1.260	BSF-F-1600/070-19.5		BSF-M-F-1A-16.0
32.5 1.280	BSF-F-1600/070-20.0				
33.0 1.299	BSF-F-1600/070-20.5				
33.5 1.319	BSF-F-1600/070-17.5				
34.0 1.339	BSF-F-1600/070-18.0				
		34.5 1.358	BSF-F-1600/070-18.5		
		35.0 1.378	BSF-F-1600/070-19.0		
		35.5 1.398	BSF-F-1600/070-19.5		
		36.0 1.417	BSF-F-1600/070-20.0		
		36.5 1.437	BSF-F-1600/070-20.5		

*Other blade options available

Order Instructions:
Refer to page 162
"How to Order"
for order
instructions and
example

Special Application?
Submit the Application
Data Sheet on **Page 214**
to Heule Tool with your
application information
for our engineering team
to review.

Submit to:
info@heuletool.com

PROGRAMMING PG. 192-193

CHANGE BLADES PG. 194

HTC015

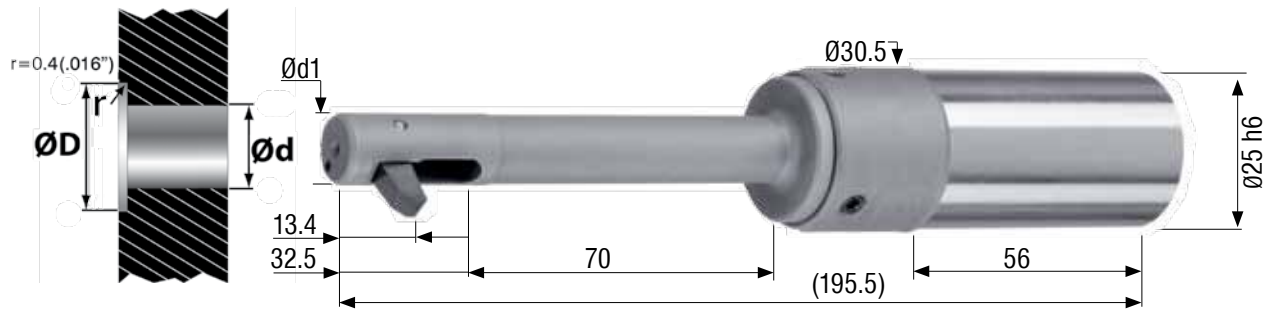

Minimum Hole $\varnothing d$	Tool Series F				
	$\varnothing d1$	C'Bore $\varnothing D$	Tool Order #	Blade Order #	
mm inches	mm inches	mm inches		Carbide, TiAlN*	
16.5 0.650	16.4 0.646	25.0 0.984	BSF-F-1650/070-19.5	BSF-M-F-1A-5.5	
		25.5 1.004	BSF-F-1650/070-20.0		
		26.0 1.024	BSF-F-1650/070-20.5		
		26.5 1.043	BSF-F-1650/070-21.0	BSF-M-F-1A-9.0	
		27.0 1.063	BSF-F-1650/070-18.0		
		27.5 1.083	BSF-F-1650/070-18.5		
		28.0 1.102	BSF-F-1650/070-19.0		
		28.5 1.122	BSF-F-1650/070-19.5		
		29.0 1.142	BSF-F-1650/070-20.0		
		29.5 1.161	BSF-F-1650/070-20.5		
		30.0 1.181	BSF-F-1650/070-21.0		
		30.5 1.201	BSF-F-1650/070-18.0		BSF-M-F-1A-12.5
		31.0 1.220	BSF-F-1650/070-18.5		
31.5 1.240	BSF-F-1650/070-19.0				
32.0 1.260	BSF-F-1650/070-19.5				
		32.5 1.280	BSF-F-1650/070-20.0	BSF-M-F-1A-16.0	
		33.0 1.299	BSF-F-1650/070-20.5		
		33.5 1.319	BSF-F-1650/070-21.0		
		34.0 1.339	BSF-F-1650/070-18.0		
		34.5 1.358	BSF-F-1650/070-18.5		
		35.0 1.378	BSF-F-1650/070-19.0		
		35.5 1.398	BSF-F-1650/070-19.5		
		36.0 1.417	BSF-F-1650/070-20.0		
		36.5 1.437	BSF-F-1650/070-20.5	BSF-M-F-1A-19.5	
		37.0 1.457	BSF-F-1650/070-21.0		
		37.5 1.476	BSF-F-1650/070-18.0		
38.0 1.496	BSF-F-1650/070-18.5				

*Other blade options available

Order Instructions:
Refer to page 162
"How to Order"
for order
instructions and
example

Special Application?
Submit the Application
Data Sheet on [Page 214](#)
to Heule Tool with your
application information
for our engineering
team to review.

Submit to:
info@heuletool.com

HOUSING
OPTIONS **PG. 189-190**

SPARE
PARTS **PG. 188**

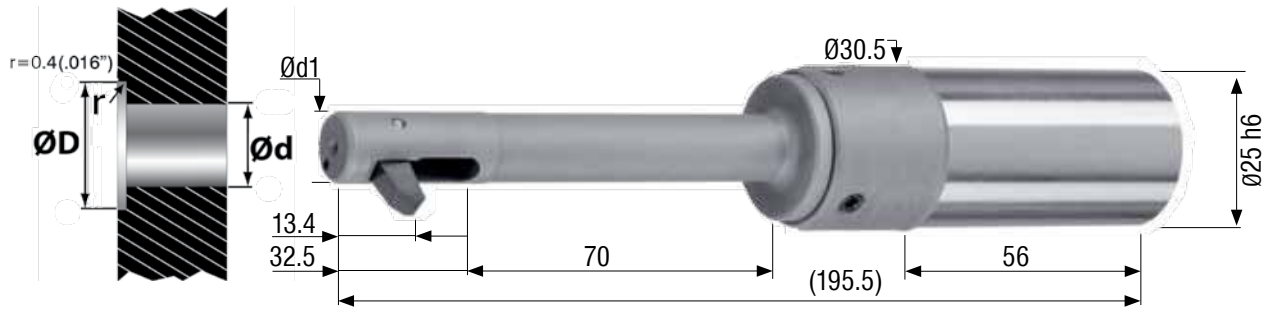

Minimum Hole $\varnothing d$	Tool Series F						
	$\varnothing d1$	C'Bore $\varnothing D$	Tool Order #	Blade Order #			
mm inches	mm inches	mm inches		Carbide, TiAlN*			
17.0 0.669	16.9 0.665	25.5 1.004	BSF-F-1700/070-20.0	BSF-M-F-1A-5.5			
		26.0 1.024	BSF-F-1700/070-20.5				
		26.5 1.043	BSF-F-1700/070-21.0				
		27.0 1.063	BSF-F-1700/070-21.5				
		27.5 1.083	BSF-F-1700/070-18.5		BSF-M-F-1A-9.0		
		28.0 1.102	BSF-F-1700/070-19.0				
		28.5 1.122	BSF-F-1700/070-19.5				
		29.0 1.142	BSF-F-1700/070-20.0				
		29.5 1.161	BSF-F-1700/070-20.5				
		30.0 1.181	BSF-F-1700/070-21.0				
					30.5 1.201	BSF-F-1700/070-21.5	BSF-M-F-1A-12.5
					31.0 1.220	BSF-F-1700/070-18.5	
31.5 1.240	BSF-F-1700/070-19.0						
32.0 1.260	BSF-F-1700/070-19.5						
32.5 1.280	BSF-F-1700/070-20.0						
33.0 1.299	BSF-F-1700/070-20.5						
33.5 1.319	BSF-F-1700/070-21.0						
34.0 1.339	BSF-F-1700/070-21.5						
34.5 1.358	BSF-F-1700/070-18.5			BSF-M-F-1A-16.0			
35.0 1.378	BSF-F-1700/070-19.0						
35.5 1.398	BSF-F-1700/070-19.5						
36.0 1.417	BSF-F-1700/070-20.0						
36.5 1.437	BSF-F-1700/070-20.5						
37.0 1.457	BSF-F-1700/070-21.0						
		37.5 1.476	BSF-F-1700/070-21.5	BSF-M-F-1A-19.5			
		38.0 1.496	BSF-F-1700/070-18.5				
		38.5 1.516	BSF-F-1700/070-19.0				
		39.0 1.535	BSF-F-1700/070-19.5				
		39.5 1.555	BSF-F-1700/070-20.0				

*Other blade options available

Order Instructions:
Refer to page 162
"How to Order"
for order
instructions and
example

Special Application?
Submit the Application
Data Sheet on **Page 214**
to Heule Tool with your
application information
for our engineering team
to review.

Submit to:
info@heuletool.com

PROGRAMMING PG. 192-193

CHANGE BLADES PG. 194

HTC015

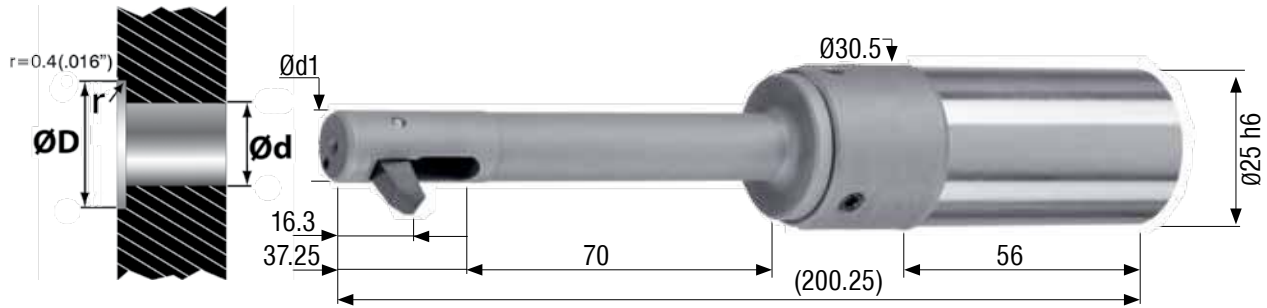

Minimum Hole $\varnothing d$	Tool Series G						
	$\varnothing d1$	C'Bore $\varnothing D$	Tool Order #	Blade Order #			
mm inches	mm inches	mm inches		Carbide, TiAlN*			
17.5 0.689	17.4 0.685	26.5 1.043	BSF-G-1750/070-20.5	BSF-M-G-1A-6.0			
		27.0 1.063	BSF-G-1750/070-21.0				
		27.5 1.083	BSF-G-1750/070-21.5				
		28.0 1.102	BSF-G-1750/070-22.0				
		28.5 1.122	BSF-G-1750/070-22.5				
		29.0 1.142	BSF-G-1750/070-23.0				
		29.5 1.161	BSF-G-1750/070-23.5				
		30.0 1.181	BSF-G-1750/070-24.0				
		30.5 1.201	30.5 1.201		30.5 1.201	BSF-G-1750/070-20.0	BSF-M-G-1A-10.5
					31.0 1.220	BSF-G-1750/070-20.5	
31.5 1.240	BSF-G-1750/070-21.0						
32.0 1.260	BSF-G-1750/070-21.5						
32.5 1.280	BSF-G-1750/070-22.0						
33.0 1.299	BSF-G-1750/070-22.5						
33.5 1.319	BSF-G-1750/070-23.0						
34.0 1.339	BSF-G-1750/070-23.5						
34.5 1.358	BSF-G-1750/070-24.0						
35.0 1.378	35.0 1.378			35.0 1.378	BSF-G-1750/070-20.0	BSF-M-G-1A-15.0	
		35.5 1.398	BSF-G-1750/070-20.5				
		36.0 1.417	BSF-G-1750/070-21.0				
		36.5 1.437	BSF-G-1750/070-21.5				
		37.0 1.457	BSF-G-1750/070-22.0				
		37.5 1.476	BSF-G-1750/070-22.5				
		38.0 1.496	BSF-G-1750/070-23.0				
		38.5 1.516	BSF-G-1750/070-23.5				
		39.0 1.535	BSF-G-1750/070-24.0				
		39.5 1.555	39.5 1.555	39.5 1.555	BSF-G-1750/070-20.0		BSF-M-G-1A-19.5
40.0 1.575	BSF-G-1750/070-20.5						
40.5 1.594	BSF-G-1750/070-21.0						

*Other blade options available

Order Instructions:
Refer to page 162
"How to Order"
for order
instructions and
example

Special Application?
Submit the Application
Data Sheet on [Page 214](#)
to Heule Tool with your
application information
for our engineering
team to review.

Submit to:
info@heuletool.com

HOUSING
OPTIONS **PG. 189-190**

SPARE
PARTS **PG. 188**

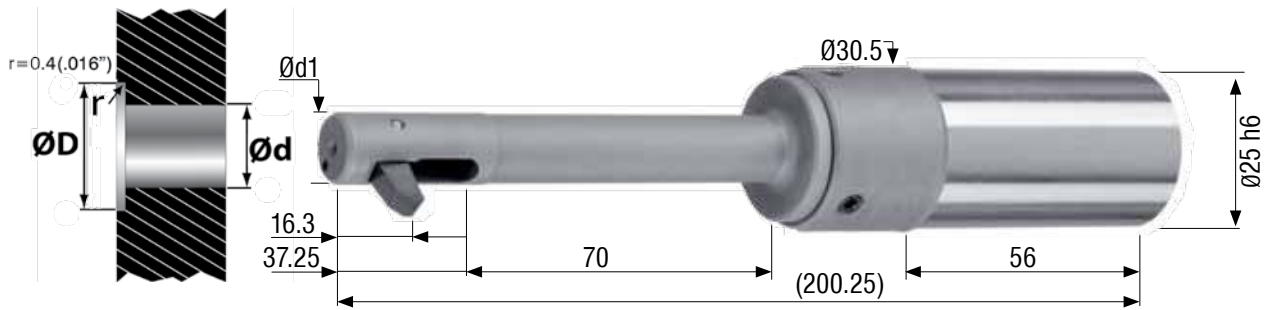

Minimum Hole $\varnothing d$	Tool Series G						
	$\varnothing d1$	C'Bore $\varnothing D$	Tool Order #	Blade Order #			
mm inches	mm inches	mm inches		Carbide, TiAlN*			
18.0 0.709	17.9 0.705	27.0 1.063	BSF-G-1800/070-21.0	BSF-M-G-1A-6.0			
		27.5 1.083	BSF-G-1800/070-21.5				
		28.0 1.102	BSF-G-1800/070-22.0				
		28.5 1.122	BSF-G-1800/070-22.5				
		29.0 1.142	BSF-G-1800/070-23.0				
		29.5 1.161	BSF-G-1800/070-23.5				
		30.0 1.181	BSF-G-1800/070-24.0				
		30.5 1.201	BSF-G-1800/070-24.5				
					31.0 1.220	BSF-G-1800/070-20.5	BSF-M-G-1A-10.5
					31.5 1.240	BSF-G-1800/070-21.0	
32.0 1.260	BSF-G-1800/070-21.5						
32.5 1.280	BSF-G-1800/070-22.0						
33.0 1.299	BSF-G-1800/070-22.5						
33.5 1.319	BSF-G-1800/070-23.0						
34.0 1.339	BSF-G-1800/070-23.5						
34.5 1.358	BSF-G-1800/070-24.0						
35.0 1.378	BSF-G-1800/070-24.5						
				35.5 1.398	BSF-G-1800/070-20.5	BSF-M-G-1A-15.0	
		36.0 1.417	BSF-G-1800/070-21.0				
		36.5 1.437	BSF-G-1800/070-21.5				
		37.0 1.457	BSF-G-1800/070-22.0				
		37.5 1.476	BSF-G-1800/070-22.5				
		38.0 1.496	BSF-G-1800/070-23.0				
		38.5 1.516	BSF-G-1800/070-23.5				
		39.0 1.535	BSF-G-1800/070-24.0				
		39.5 1.555	BSF-G-1800/070-24.5				
				40.0 1.575	BSF-G-1800/070-20.5		BSF-M-G-1A-19.5
40.5 1.594	BSF-G-1800/070-21.0						
41.0 1.614	BSF-G-1800/070-21.5						
41.5 1.634	BSF-G-1800/070-22.0						

*Other blade options available

Order Instructions:
Refer to page 162
"How to Order"
for order
instructions and
example

Special Application?
Submit the Application
Data Sheet on **Page 214**
to Heule Tool with your
application information
for our engineering team
to review.

Submit to:
info@heuletool.com

PROGRAMMING PG. 192-193

CHANGE BLADES PG. 194

HTC015

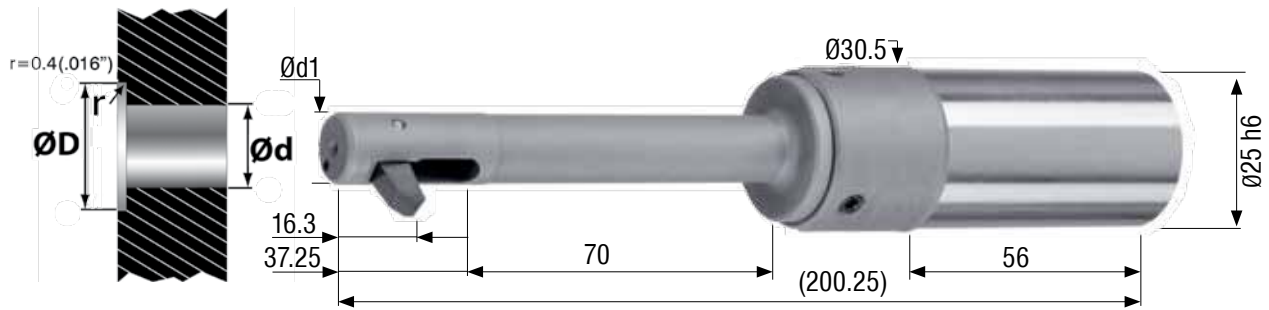

Minimum Hole $\varnothing d$	Tool Series G				
	$\varnothing d1$	C'Bore $\varnothing D$	Tool Order #	Blade Order #	
mm inches	mm inches	mm inches		Carbide, TiAlN*	
18.5 0.728	18.4 0.724	28.0 1.102	BSF-G-1850/070-22.0	BSF-M-G-1A-6.0	
		28.5 1.122	BSF-G-1850/070-22.5		
		29.0 1.142	BSF-G-1850/070-23.0		
		29.5 1.161	BSF-G-1850/070-23.5		
		30.0 1.181	BSF-G-1850/070-24.0		
		30.5 1.201	BSF-G-1850/070-24.5		
		31.0 1.220	BSF-G-1850/070-25.0		
		31.5 1.240	BSF-G-1850/070-21.0		BSF-M-G-1A-10.5
		32.0 1.260	BSF-G-1850/070-21.5		
		32.5 1.280	BSF-G-1850/070-22.0		
		33.0 1.299	BSF-G-1850/070-22.5		
		33.5 1.319	BSF-G-1850/070-23.0		
		34.0 1.339	BSF-G-1850/070-23.5		
		34.5 1.358	BSF-G-1850/070-24.0		
		35.0 1.378	BSF-G-1850/070-24.5		
		35.5 1.398	BSF-G-1850/070-25.0		
		36.0 1.417	BSF-G-1850/070-21.0	BSF-M-G-1A-15.0	
		36.5 1.437	BSF-G-1850/070-21.5		
		37.0 1.457	BSF-G-1850/070-22.0		
		37.5 1.476	BSF-G-1850/070-22.5		
		38.0 1.496	BSF-G-1850/070-23.0		
		38.5 1.516	BSF-G-1850/070-23.5		
		39.0 1.535	BSF-G-1850/070-24.0		
		39.5 1.555	BSF-G-1850/070-24.5		
		40.0 1.575	BSF-G-1850/070-25.0	BSF-M-G-1A-19.5	
		40.5 1.594	BSF-G-1850/070-21.0		
		41.0 1.614	BSF-G-1850/070-21.5		
		41.5 1.634	BSF-G-1850/070-22.0		
		42.0 1.654	BSF-G-1850/070-22.5		
		42.5 1.673	BSF-G-1850/070-23.0		
		43.0 1.693	BSF-G-1850/070-23.5		

Order Instructions:

Refer to page 162
"How to Order"
for order
instructions and
example

Special Application?

Submit the Application
Data Sheet on [Page 214](#)
to Heule Tool with your
application information
for our engineering
team to review.

Submit to:
info@heuletool.com

HOUSING
OPTIONS PG.
189-190

SPARE
PARTS PG.
188

*Other blade options available

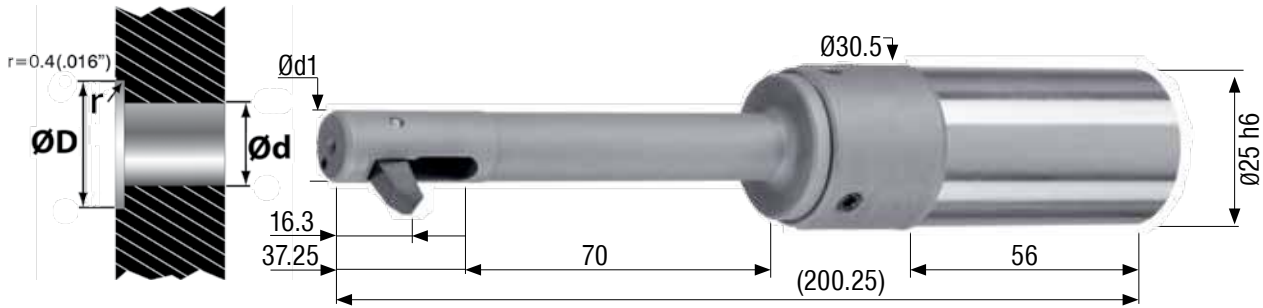

Minimum Hole Ød	Tool Series G				
	Ød1	C'Bore ØD	Tool Order #	Blade Order #	
mm inches	mm inches	mm inches		Carbide, TiAlN*	
19.0 0.748	18.9 0.744	28.5 1.122	BSF-G-1900/070-22.5	BSF-M-G-1A-6.0	
		29.0 1.142	BSF-G-1900/070-23.0		
		29.5 1.161	BSF-G-1900/070-23.5		
		30.0 1.181	BSF-G-1900/070-24.0		
		30.5 1.201	BSF-G-1900/070-24.5		
		31.0 1.220	BSF-G-1900/070-25.0		
		31.5 1.240	BSF-G-1900/070-25.5		
		32.0 1.260	BSF-G-1900/070-21.5		BSF-M-G-1A-10.5
		32.5 1.280	BSF-G-1900/070-22.0		
		33.0 1.299	BSF-G-1900/070-22.5		
		33.5 1.319	BSF-G-1900/070-23.0		
		34.0 1.339	BSF-G-1900/070-23.5		
		34.5 1.358	BSF-G-1900/070-24.0		
		35.0 1.378	BSF-G-1900/070-24.5		
		35.5 1.398	BSF-G-1900/070-25.0		
		36.0 1.417	BSF-G-1900/070-25.5		
		36.5 1.437	BSF-G-1900/070-21.5		
		37.0 1.457	BSF-G-1900/070-22.0		
		37.5 1.476	BSF-G-1900/070-22.5		
38.0 1.496	BSF-G-1900/070-23.0				
38.5 1.516	BSF-G-1900/070-23.5				
39.0 1.535	BSF-G-1900/070-24.0				
39.5 1.555	BSF-G-1900/070-24.5				
40.0 1.575	BSF-G-1900/070-25.0				
40.5 1.594	BSF-G-1900/070-25.5				
41.0 1.614	BSF-G-1900/070-21.5	BSF-M-G-1A-19.5			
41.5 1.634	BSF-G-1900/070-22.0				
42.0 1.654	BSF-G-1900/070-22.5				
42.5 1.673	BSF-G-1900/070-23.0				
43.0 1.693	BSF-G-1900/070-23.5				
43.5 1.713	BSF-G-1900/070-24.0				
44.0 1.732	BSF-G-1900/070-24.5				

Order Instructions:
Refer to page 162
"How to Order"
for order
instructions and
example

Special Application?
Submit the Application
Data Sheet on **Page 214**
to Heule Tool with your
application information
for our engineering team
to review.

Submit to:
info@heuletool.com

PROGRAMMING PG. 192-193

CHANGE BLADES PG. 194

HTC015

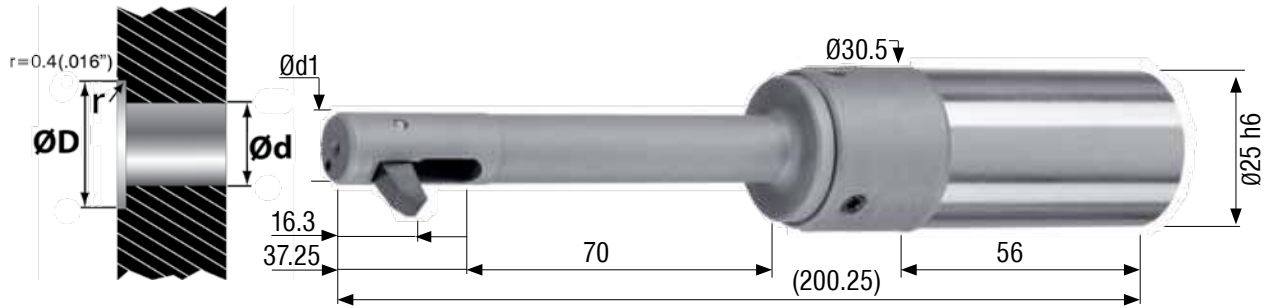

Minimum Hole \varnothing	Tool Series G				
	$\varnothing d1$	C'Bore $\varnothing D$	Tool Order #	Blade Order #	
mm inches	mm inches	mm inches		Carbide, TiAlN*	
19.5 0.768	19.4 0.764	29.5 1.161	BSF-G-1950/070-23.5	BSF-M-G-1A-6.0	
		30.0 1.181	BSF-G-1950/070-24.0		
		30.5 1.201	BSF-G-1950/070-24.5		
		31.0 1.220	BSF-G-1950/070-25.0		
		31.5 1.240	BSF-G-1950/070-25.5		
		32.0 1.260	BSF-G-1950/070-26.0		
		32.5 1.280	BSF-G-1950/070-22.0		BSF-M-G-1A-10.5
		33.0 1.299	BSF-G-1950/070-22.5		
		33.5 1.319	BSF-G-1950/070-23.0		
		34.0 1.339	BSF-G-1950/070-23.5		
		34.5 1.358	BSF-G-1950/070-24.0		
		35.0 1.378	BSF-G-1950/070-24.5		
35.5 1.398	36.0 1.417	35.5 1.398	BSF-G-1950/070-25.0	BSF-M-G-1A-15.0	
		36.0 1.417	BSF-G-1950/070-25.5		
		36.5 1.437	BSF-G-1950/070-26.0		
		37.0 1.457	BSF-G-1950/070-22.0		
		37.5 1.476	BSF-G-1950/070-22.5		
		38.0 1.496	BSF-G-1950/070-23.0		
		38.5 1.516	BSF-G-1950/070-23.5		
		39.0 1.535	BSF-G-1950/070-24.0		
		39.5 1.555	BSF-G-1950/070-24.5		
		40.0 1.575	BSF-G-1950/070-25.0		
		40.5 1.594	BSF-G-1950/070-25.5		
		41.0 1.614	BSF-G-1950/070-26.0		
41.5 1.634	42.0 1.654	41.5 1.634	BSF-G-1950/070-22.0	BSF-M-G-1A-19.5	
		42.0 1.654	BSF-G-1950/070-22.5		
		42.5 1.673	BSF-G-1950/070-23.0		
		43.0 1.693	BSF-G-1950/070-23.5		
		43.5 1.713	BSF-G-1950/070-24.0		
		44.0 1.732	BSF-G-1950/070-24.5		
		44.5 1.752	BSF-G-1950/070-25.0		
		45.0 1.772	BSF-G-1950/070-25.5		

Order Instructions:
Refer to page 162
"How to Order"
for order
instructions and
example

Special Application?
Submit the Application
Data Sheet on [Page 214](#)
to Heule Tool with your
application information
for our engineering
team to review.

Submit to:
info@heuletool.com

HOUSING
OPTIONS PG.
189-190

SPARE
PARTS PG.
188

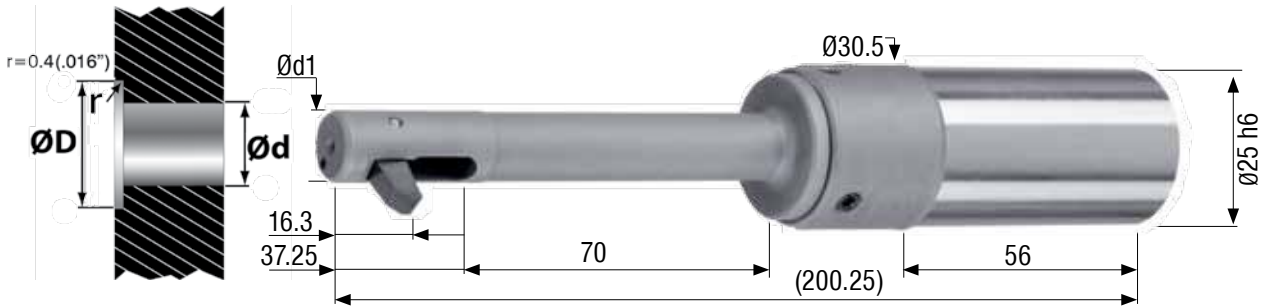

Minimum Hole Ød	Tool Series G								
	Ød1	C'Bore ØD	Tool Order #	Blade Order #					
mm inches	mm inches	mm inches	Carbide, TiAlN*						
20.0 0.787	19.9 0.783	30.0 1.181	BSF-G-2000/070-24.0	BSF-M-G-1A-6.0					
		30.5 1.201	BSF-G-2000/070-24.5						
		31.0 1.220	BSF-G-2000/070-25.0						
		31.5 1.240	BSF-G-2000/070-25.5						
		32.0 1.260	BSF-G-2000/070-26.0						
		32.5 1.280	BSF-G-2000/070-26.5						
		33.0 1.299	33.0 1.299	33.0 1.299	BSF-G-2000/070-22.5	BSF-M-G-1A-10.5			
				33.5 1.319	BSF-G-2000/070-23.0				
				34.0 1.339	BSF-G-2000/070-23.5				
				34.5 1.358	BSF-G-2000/070-24.0				
				35.0 1.378	BSF-G-2000/070-24.5				
				35.5 1.398	BSF-G-2000/070-25.0				
				36.0 1.417	BSF-G-2000/070-25.5				
				36.5 1.437	BSF-G-2000/070-26.0				
				37.0 1.457	BSF-G-2000/070-26.5				
				37.5 1.476	37.5 1.476		37.5 1.476	BSF-G-2000/070-22.5	BSF-M-G-1A-15.0
							38.0 1.496	BSF-G-2000/070-23.0	
							38.5 1.516	BSF-G-2000/070-23.5	
39.0 1.535	BSF-G-2000/070-24.0								
39.5 1.555	BSF-G-2000/070-24.5								
40.0 1.575	BSF-G-2000/070-25.0								
40.5 1.594	BSF-G-2000/070-25.5								
41.0 1.614	BSF-G-2000/070-26.0								
41.5 1.634	BSF-G-2000/070-26.5								
42.0 1.654	42.0 1.654	42.0 1.654	BSF-G-2000/070-22.5			BSF-M-G-1A-19.5			
		42.5 1.673	BSF-G-2000/070-23.0						
		43.0 1.693	BSF-G-2000/070-23.5						
		43.5 1.713	BSF-G-2000/070-24.0						
		44.0 1.732	BSF-G-2000/070-24.5						
		44.5 1.752	BSF-G-2000/070-25.0						
		45.0 1.772	BSF-G-2000/070-25.5						
		45.5 1.791	BSF-G-2000/070-26.0						
		46.0 1.811	BSF-G-2000/070-26.5						

Order Instructions:
Refer to page 162
"How to Order"
for order
instructions and
example

Special Application?
Submit the Application
Data Sheet on [Page 214](#)
to Heule Tool with your
application information
for our engineering team
to review.

Submit to:
info@heuletool.com

PROGRAMMING **PG. 192-193**

CHANGE BLADES **PG. 194**

Tool Description

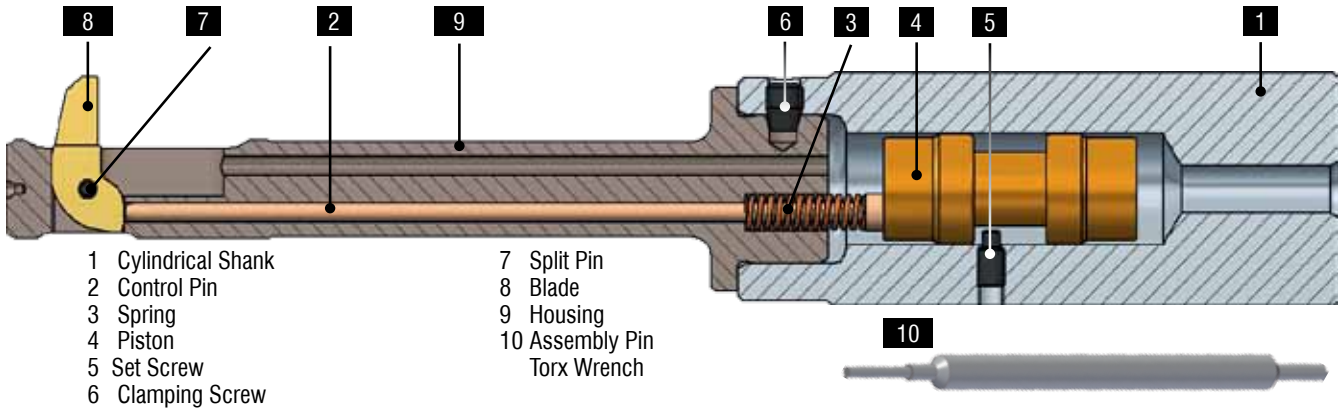

- 1 Cylindrical Shank
- 2 Control Pin
- 3 Spring
- 4 Piston
- 5 Set Screw
- 6 Clamping Screw
- 7 Split Pin
- 8 Blade
- 9 Housing
- 10 Assembly Pin
Torx Wrench

SPARE PARTS		SERIES A	SERIES B	SERIES C
1	CYLINDRICAL SHANK	BSF-S-0003	BSF-S-0003	BSF-S-0003
2	CONTROL PIN	BSF-B-0001 (6.5) BSF-B-0002 (7.0)	BSF-B-0003 (7.5) BSF-B-0004 (8.5)	BSF-B-0005 (9.0)
3	SPRING	GH-H-F-0052	GH-H-F-0052	GH-H-F-0053
4	PISTON	BSF-E-0014	BSF-E-0014	BSF-E-0014
5	SET SCREW	GH-H-S-0302	GH-H-S-0302	GH-H-S-0302
6	CLAMPING SCREW	GH-H-S-0201	GH-H-S-0201	GH-H-S-0201
7	SPLIT PIN	BSF-E-0009	BSF-E-0018	BSF-E-0010
10	ASSEMBLY PIN WRENCH	BSF-V-0009 GH-H-S-2023	BSF-V-0009 GH-H-S-2023	BSF-V-0006 GH-H-S-2023
SPARE PARTS		SERIES D	SERIES E	SERIES F
1	CYLINDRICAL SHANK	BSF-S-0003	BSF-S-0003	BSF-S-0004
2	CONTROL PIN	BSF-B-0006 (10.5) BSF-B-0007 (11.5)	BSF-B-0008 (12.0) BSF-B-0009 (14.0)	BSF-B-0010 (14.5) BSF-B-0011 (16.0)
3	SPRING	GH-H-F-0053	GH-H-F-0053	GH-H-F-0051
4	PISTON	BSF-E-0014	BSF-E-0014	BSF-E-0014
5	SET SCREW	GH-H-S-0302	GH-H-S-0302	GH-H-S-0302
6	CLAMPING SCREW	GH-H-S-0201	GH-H-S-0201	GH-H-S-0202
7	SPLIT PIN	BSF-E-0019	BSF-E-0011	BSF-E-0012
10	ASSEMBLY PIN WRENCH	BSF-V-0006 GH-H-S-2023	BSF-V-0007 GH-H-S-2023	BSF-V-0007 GH-H-S-2100
SPARE PARTS		SERIES G		
1	CYLINDRICAL SHANK	BSF-S-0004		
2	CONTROL PIN	BSF-B-0012 (17.5) BSF-B-0013 (20.5)		
3	SPRING	GH-H-F-0051		
4	PISTON	BSF-E-0014		
5	SET SCREW	GH-H-S-0302		
6	CLAMPING SCREW	GH-H-S-0202		
7	SPLIT PIN	BSF-E-0013		
10	ASSEMBLY PIN WRENCH	BSF-V-0008 GH-H-S-2100		

1- Clamping screws sold individually (3x needed)

	(8) Carbide TiAlN BLADES	(9) HOUSING		(9) HOUSING		
		TOOL NUMBER	HOUSING	TOOL NUMBER	HOUSING	
SERIES A	BSF-M-A-1A-3.0	BSF-A-0650/040-6.5	BSF-N-A-0650/N025/040	SERIES E	BSF-E-1200/050-13.0	BSF-N-E-1200/N050/050
	BSF-M-A-1A-4.5	BSF-A-0650/040-7.0	BSF-N-A-0650/0000/040		BSF-E-1200/050-13.5	BSF-N-E-1200/N025/050
	BSF-M-A-1A-6.0	BSF-A-0650/040-7.5	BSF-N-A-0650/P025/040		BSF-E-1200/050-14.0	BSF-N-E-1200/0000/050
	BSF-M-A-1A-7.5	BSF-A-0700/040-7.0	BSF-N-A-0700/0000/040		BSF-E-1200/050-14.5	BSF-N-E-1200/P025/050
	BSF-M-A-1A-9.0	BSF-A-0700/040-7.5	BSF-N-A-0700/P025/040		BSF-E-1200/050-15.0	BSF-N-E-1200/P050/050
SERIES B	BSF-M-B-1A-3.5	BSF-A-0700/040-8.0	BSF-N-A-0700/P050/040	BSF-E-1250/050-13.5	BSF-N-E-1250/N025/050	
	BSF-M-B-1A-5.0	BSF-B-0750/040-7.5	BSF-N-B-0750/N025/040	BSF-E-1250/050-14.0	BSF-N-E-1250/0000/050	
	BSF-M-B-1A-6.5	BSF-B-0750/040-8.0	BSF-N-B-0750/0000/040	BSF-E-1250/050-14.5	BSF-N-E-1250/P025/050	
	BSF-M-B-1A-8.0	BSF-B-0750/040-8.5	BSF-N-B-0750/P025/040	BSF-E-1250/050-15.0	BSF-N-E-1250/P050/050	
	BSF-M-B-1A-9.5	BSF-B-0800/040-8.0	BSF-N-B-0800/0000/040	BSF-E-1250/050-15.5	BSF-N-E-1250/P075/050	
BSF-M-B-1A-11.0	BSF-B-0800/040-8.5	BSF-N-B-0800/P025/040	SERIES E	BSF-E-1300/050-14.0	BSF-N-E-1300/0000/050	
SERIES C	BSF-M-C-1A-4.0	BSF-B-0800/040-9.0		BSF-N-B-0800/P050/040	BSF-E-1300/050-14.5	BSF-N-E-1300/P025/050
	BSF-M-C-1A-5.5	BSF-B-0850/040-8.5		BSF-N-B-0850/P025/040	BSF-E-1300/050-15.0	BSF-N-E-1300/P050/050
	BSF-M-C-1A-7.0	BSF-B-0850/040-9.0		BSF-N-B-0850/P050/040	BSF-E-1300/050-15.5	BSF-N-E-1300/P075/050
	BSF-M-C-1A-8.5	BSF-B-0850/040-9.5		BSF-N-B-0850/P075/040	BSF-E-1300/050-16.0	BSF-N-E-1300/P100/050
	BSF-M-C-1A-10.0	BSF-C-0900/050-9.5	BSF-N-C-0900/N025/050	BSF-E-1350/050-14.5	BSF-N-E-1350/P025/050	
BSF-M-C-1A-11.5	BSF-C-0900/050-10.0	BSF-N-C-0900/0000/050	BSF-E-1350/050-15.0	BSF-N-E-1350/P050/050		
SERIES D	BSF-M-D-1A-4.5	BSF-C-0900/050-10.5	BSF-N-C-0900/P025/050	BSF-E-1350/050-15.5	BSF-N-E-1350/P075/050	
	BSF-M-D-1A-7.0	BSF-C-0950/050-10.0	BSF-N-C-0950/0000/050	BSF-E-1350/050-16.0	BSF-N-E-1350/P100/050	
	BSF-M-D-1A-9.5	BSF-C-0950/050-10.5	BSF-N-C-0950/P025/050	BSF-E-1350/050-16.5	BSF-N-E-1350/P125/050	
	BSF-M-D-1A-12.0	BSF-C-0950/050-11.0	BSF-N-C-0950/P050/050	BSF-E-1400/050-15.0	BSF-N-E-1400/P050/050	
	BSF-M-D-1A-14.5	BSF-C-1000/050-10.5	BSF-N-C-1000/P025/050	BSF-E-1400/050-15.5	BSF-N-E-1400/P075/050	
SERIES E	BSF-M-E-1A-5.0	BSF-C-1000/050-11.0	BSF-N-C-1000/P050/050	BSF-E-1400/050-16.0	BSF-N-E-1400/P100/050	
	BSF-M-E-1A-7.5	BSF-C-1000/050-11.5	BSF-N-C-1000/P075/050	BSF-E-1400/050-16.5	BSF-N-E-1400/P125/050	
	BSF-M-E-1A-10.0	BSF-D-1050/050-11.0	BSF-N-D-1050/N050/050	BSF-E-1400/050-17.0	BSF-N-E-1400/P150/050	
	BSF-M-E-1A-12.5	BSF-D-1050/050-11.5	BSF-N-D-1050/N025/050			
	BSF-M-E-1A-15.0	BSF-D-1050/050-12.0	BSF-N-D-1050/0000/050			
SERIES F	BSF-M-F-1A-5.5	BSF-D-1050/050-12.5	BSF-N-D-1050/P025/050			
	BSF-M-F-1A-9.0	BSF-D-1050/050-13.0	BSF-N-D-1050/P050/050			
	BSF-M-F-1A-12.5	BSF-D-1100/050-11.5	BSF-N-D-1100/N025/050			
	BSF-M-F-1A-16.0	BSF-D-1100/050-12.0	BSF-N-D-1100/0000/050			
	BSF-M-F-1A-19.5	BSF-D-1100/050-12.5	BSF-N-D-1100/P025/050			
SERIES G	BSF-M-G-1A-6.0	BSF-D-1100/050-13.0	BSF-N-D-1100/P050/050			
	BSF-M-G-1A-10.5	BSF-D-1100/050-13.5	BSF-N-D-1100/P075/050			
	BSF-M-G-1A-15.0	BSF-D-1150/050-12.0	BSF-N-D-1150/0000/050			
	SERIES G	BSF-M-G-1A-19.5	BSF-D-1150/050-12.5	BSF-N-D-1150/P025/050		
			BSF-D-1150/050-13.0	BSF-N-D-1150/P050/050		
		BSF-D-1150/050-13.5	BSF-N-D-1150/P075/050			
		BSF-D-1150/050-14.0	BSF-N-D-1150/P100/050			

Series F and G on next page

SERIES F (9)		SERIES G (9)	
TOOL NUMBER	HOUSING	TOOL NUMBER	HOUSING
BSF-F-1450/070-16.0	BSF-N-F-1450/N075/070	BSF-G-1750/070-20.0	BSF-N-G-1750/N100/070
BSF-F-1450/070-16.5	BSF-N-F-1450/N050/070	BSF-G-1750/070-20.5	BSF-N-G-1750/N075/070
BSF-F-1450/070-17.0	BSF-N-F-1450/N025/070	BSF-G-1750/070-21.0	BSF-N-G-1750/N050/070
BSF-F-1450/070-17.5	BSF-N-F-1450/0000/070	BSF-G-1750/070-21.5	BSF-N-G-1750/N025/070
BSF-F-1450/070-18.0	BSF-N-F-1450/P025/070	BSF-G-1750/070-22.0	BSF-N-G-1750/0000/070
BSF-F-1450/070-18.5	BSF-N-F-1450/P050/070	BSF-G-1750/070-22.5	BSF-N-G-1750/P025/070
BSF-F-1450/070-19.0	BSF-N-F-1450/P075/070	BSF-G-1750/070-23.0	BSF-N-G-1750/P050/070
BSF-F-1500/070-16.5	BSF-N-F-1500/N050/070	BSF-G-1750/070-23.5	BSF-N-G-1750/P075/070
BSF-F-1500/070-17.0	BSF-N-F-1500/N025/070	BSF-G-1750/070-24.0	BSF-N-G-1750/P100/070
BSF-F-1500/070-17.5	BSF-N-F-1500/0000/070	BSF-G-1800/070-20.5	BSF-N-G-1800/N075/070
BSF-F-1500/070-18.0	BSF-N-F-1500/P025/070	BSF-G-1800/070-21.0	BSF-N-G-1800/N050/070
BSF-F-1500/070-18.5	BSF-N-F-1500/P050/070	BSF-G-1800/070-21.5	BSF-N-G-1800/N025/070
BSF-F-1500/070-19.0	BSF-N-F-1500/P075/070	BSF-G-1800/070-22.0	BSF-N-G-1800/0000/070
BSF-F-1500/070-19.5	BSF-N-F-1500/P100/070	BSF-G-1800/070-22.5	BSF-N-G-1800/P025/070
BSF-F-1550/070-17.0	BSF-N-F-1550/N025/070	BSF-G-1800/070-23.0	BSF-N-G-1800/P050/070
BSF-F-1550/070-17.5	BSF-N-F-1550/0000/070	BSF-G-1800/070-23.5	BSF-N-G-1800/P075/070
BSF-F-1550/070-18.0	BSF-N-F-1550/P025/070	BSF-G-1800/070-24.0	BSF-N-G-1800/P100/070
BSF-F-1550/070-18.5	BSF-N-F-1550/P050/070	BSF-G-1800/070-24.5	BSF-N-G-1800/P125/070
BSF-F-1550/070-19.0	BSF-N-F-1550/P075/070	BSF-G-1850/070-21.0	BSF-N-G-1850/N050/070
BSF-F-1550/070-19.5	BSF-N-F-1550/P100/070	BSF-G-1850/070-21.5	BSF-N-G-1850/N025/070
BSF-F-1550/070-20.0	BSF-N-F-1550/P125/070	BSF-G-1850/070-22.0	BSF-N-G-1850/0000/070
BSF-F-1600/070-17.5	BSF-N-F-1600/0000/070	BSF-G-1850/070-22.5	BSF-N-G-1850/P025/070
BSF-F-1600/070-18.0	BSF-N-F-1600/P025/070	BSF-G-1850/070-23.0	BSF-N-G-1850/P050/070
BSF-F-1600/070-18.5	BSF-N-F-1600/P050/070	BSF-G-1850/070-23.5	BSF-N-G-1850/P075/070
BSF-F-1600/070-19.0	BSF-N-F-1600/P075/070	BSF-G-1850/070-24.0	BSF-N-G-1850/P100/070
BSF-F-1600/070-19.5	BSF-N-F-1600/P100/070	BSF-G-1850/070-24.5	BSF-N-G-1850/P125/070
BSF-F-1600/070-20.0	BSF-N-F-1600/P125/070	BSF-G-1850/070-25.0	BSF-N-G-1850/P150/070
BSF-F-1600/070-20.5	BSF-N-F-1600/P150/070	BSF-G-1900/070-21.5	BSF-N-G-1900/N025/070
BSF-F-1650/070-18.0	BSF-N-F-1650/P025/070	BSF-G-1900/070-22.0	BSF-N-G-1900/0000/070
BSF-F-1650/070-18.5	BSF-N-F-1650/P050/070	BSF-G-1900/070-22.5	BSF-N-G-1900/P025/070
BSF-F-1650/070-19.0	BSF-N-F-1650/P075/070	BSF-G-1900/070-23.0	BSF-N-G-1900/P050/070
BSF-F-1650/070-19.5	BSF-N-F-1650/P100/070	BSF-G-1900/070-23.5	BSF-N-G-1900/P075/070
BSF-F-1650/070-20.0	BSF-N-F-1650/P125/070	BSF-G-1900/070-24.0	BSF-N-G-1900/P100/070
BSF-F-1650/070-20.5	BSF-N-F-1650/P150/070	BSF-G-1900/070-24.5	BSF-N-G-1900/P125/070
BSF-F-1650/070-21.0	BSF-N-F-1650/P175/070	BSF-G-1900/070-25.0	BSF-N-G-1900/P150/070
BSF-F-1700/070-18.5	BSF-N-F-1700/P050/070	BSF-G-1900/070-25.5	BSF-N-G-1900/P175/070
BSF-F-1700/070-19.0	BSF-N-F-1700/P075/070	BSF-G-1950/070-22.0	BSF-N-G-1950/0000/070
BSF-F-1700/070-19.5	BSF-N-F-1700/P100/070	BSF-G-1950/070-22.5	BSF-N-G-1950/P025/070
BSF-F-1700/070-20.0	BSF-N-F-1700/P125/070	BSF-G-1950/070-23.0	BSF-N-G-1950/P050/070
BSF-F-1700/070-20.5	BSF-N-F-1700/P150/070	BSF-G-1950/070-23.5	BSF-N-G-1950/P075/070
BSF-F-1700/070-21.0	BSF-N-F-1700/P175/070	BSF-G-1950/070-24.0	BSF-N-G-1950/P100/070
BSF-F-1700/070-21.5	BSF-N-F-1700/P200/070	BSF-G-1950/070-24.5	BSF-N-G-1950/P125/070
		BSF-G-1950/070-25.0	BSF-N-G-1950/P150/070
		BSF-G-1950/070-25.5	BSF-N-G-1950/P175/070
		BSF-G-1950/070-26.0	BSF-N-G-1950/P200/070
		BSF-G-2000/070-22.5	BSF-N-G-2000/P025/070
		BSF-G-2000/070-23.0	BSF-N-G-2000/P050/070
		BSF-G-2000/070-23.5	BSF-N-G-2000/P075/070
		BSF-G-2000/070-24.0	BSF-N-G-2000/P100/070
		BSF-G-2000/070-24.5	BSF-N-G-2000/P125/070
		BSF-G-2000/070-25.0	BSF-N-G-2000/P150/070
		BSF-G-2000/070-25.5	BSF-N-G-2000/P175/070
		BSF-G-2000/070-26.0	BSF-N-G-2000/P200/070
		BSF-G-2000/070-26.5	BSF-N-G-2000/P225/070

COFA | SNAP | VEX-S | VEX-P | COMBI | DEFA | GH-K | BSF | SOLO | GH-Z/E

Blade Working Principle

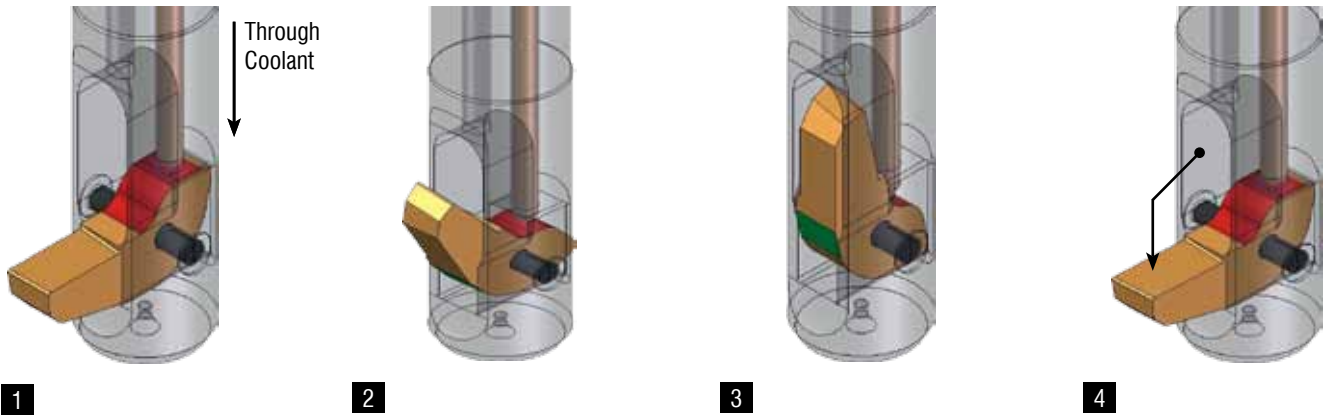

- 1 With the coolant on, the control pin is forcing the blade (red color) to retract into the blade housing.
- 2 The control pin, while still under coolant pressure, supplies pressure to the back of the blade which forces the blade to fully retract.
- 3 The control pin holds the blade in the retracted position and the tool may be moved in the axial direction (Z-axis) through the hole.
- 4 Turn off the through coolant and start the spindle rotation at the recommended activation speed. With centrifugal force the blade will swing out into working position. The through coolant may be turned on when the cutting blade is in full contact with the work piece. When the counterbore operation is finished the through coolant is turned off, the insert exits the counterbore. Reactivate the through coolant, the blade will retract again.

CNC Machine Requirements

BSF Tools require a minimum 280 PSI (approximately 19.3 BAR) and 2000-5000 RPM to properly activate. Typical spotface diameter tolerances of +/-0.1 mm (0.004"). The recommended tool diameters should be 0.004"-0.016" below the minimum hole diameter. All materials can be machined but special considerations should be given to interruptions and long chipping materials. All tools are ground with large cylindrical shanks with h6 tolerances. Proper tool holding may include hydraulic, mill chuck or precision collet holders. Coolant filtration required (<25µm).

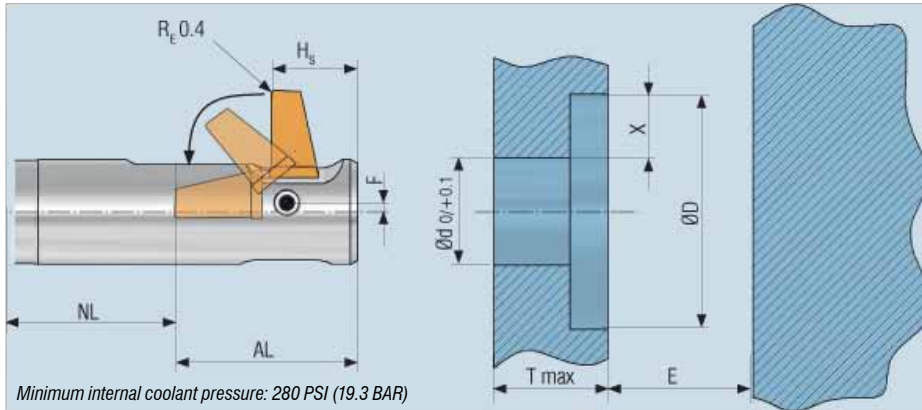

Minimum internal coolant pressure: 280 PSI (19.3 BAR)

Legend

Ød	Bore diameter (tol. 0/+0.1)
ØD	Counterbore diameter
X	Cutting edge width
E	Distance interfering edge
NL	Working length
AL	Swing length
H _s	Cutting position
R _e	Edge radius standard 0.4 mm
T max	Maximum material thickness



1
M05 (spindle stop)
M88 (internal coolant on)
G04 X2.0 (dwell 2 seconds)

Position tool above part, spindle off, internal coolant on, dwell 2- 5 seconds (dwell time depends on pump), blade retracts.

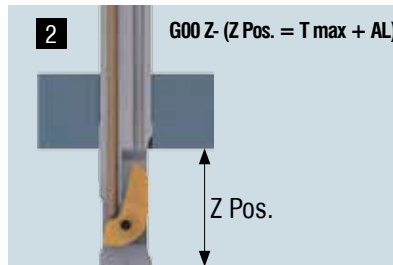

2
G00 Z- (Z Pos. = T max + AL)

Position tool through the hole (Z Pos. = T max + AL).

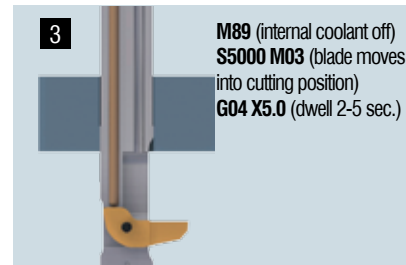

3
M89 (internal coolant off)
S5000 M03 (blade moves into cutting position)
G04 X5.0 (dwell 2-5 sec.)

Internal coolant off and start spindle 2000-5000 RPM, dwell 2-5 seconds (dwell depends on time it takes to purge the internal coolant), blade moves into cutting position.

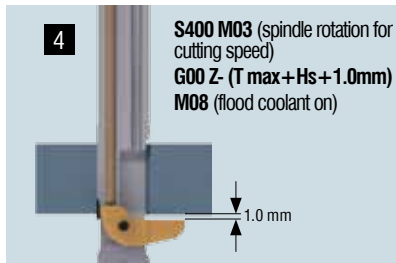

4
S400 M03 (spindle rotation for cutting speed)
G00 Z- (T max+H_s+1.0mm)
M08 (flood coolant on)

Turn on spindle at cutting speed. Position cutting blade 1 mm below T max (note tolerance and burr size), turn on flood coolant.

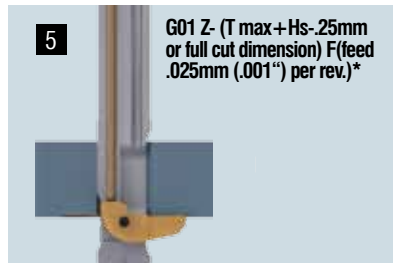

5
G01 Z- (T max+H_s-.25mm or full cut dimension) F(feed .025mm (.001") per rev)*

Move Z axis for cutting (approximately .25 mm deep or until full cut) with cutting feed rate.
 *continue to desired depth of cut unless optional next step is required

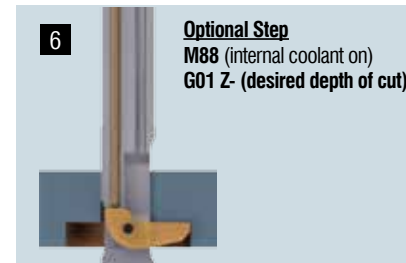

Optional Step
M88 (internal coolant on)
G01 Z- (desired depth of cut)

Optional: For deep bores, turn internal coolant on and feed to desired depth. Insert must be in full cut.

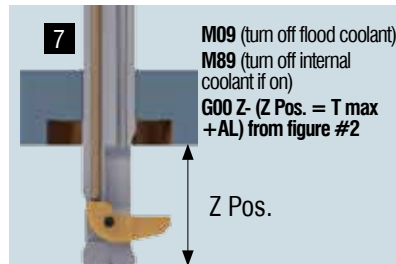

7
M09 (turn off flood coolant)
M89 (turn off internal coolant if on)
G00 Z- (Z Pos. = T max +AL) from figure #2

If the counterbore depth is reached, switch off internal coolant and external coolant, and rapid back to Z position (Z Pos. = T max + AL).



8
M05 (spindle off)
M88 (internal coolant on)
G04 X5.0 (dwell 5 seconds)

Spindle stop, internal coolant on, dwell 2-5 seconds, blade retracts.

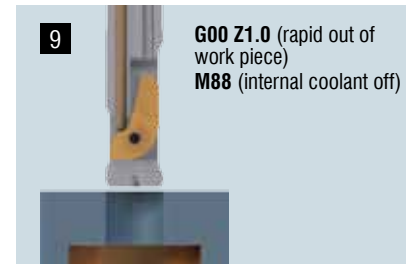

9
G00 Z1.0 (rapid out of work piece)
M88 (internal coolant off)

Position tool out of work piece. Internal coolant off or move to next hole location.

*Programming codes vary per machine make and model

1 - Check swing length 2 - Check activation speed on pg 193 3 - Reference cutting data on pg 193

Cutting Data

Material	Blade material	SFM	Feed f (mm/rev)						
			Series and bore diameter						
			A	B	C	D	E	F	G
			6.50 - 7.00	7.50 - 8.50	9.00 - 10.00	10.50 - 11.50	12.00 - 14.00	14.50 - 17.00	17.50 - 21.00
Carbon steel < 200 HB	HM	130-260	0.02-0.04	0.02-0.04	0.02-0.04	0.03-0.06	0.03-0.08	0.03-0.08	0.03-0.08
	HSS	65-130							
Carbon steel > 200 HB	HM	100-230	0.02-0.03	0.02-0.03	0.02-0.03	0.02-0.05	0.03-0.06	0.03-0.06	0.03-0.08
	HSS	50-100							
Alloy steel < 240 HB	HM	100-200	0.02-0.04	0.02-0.04	0.02-0.04	0.03-0.06	0.03-0.08	0.03-0.08	0.03-0.08
	HSS	50-100							
Tool steel < 300 HB	HM	65-130	0.02-0.04	0.02-0.04	0.02-0.04	0.03-0.06	0.03-0.08	0.03-0.08	0.03-0.08
	HSS	30-50							
Tool steel > 300 HB	HM	30-30	0.02-0.03	0.02-0.03	0.02-0.03	0.02-0.04	0.03-0.05	0.03-0.05	0.03-0.06
	HSS	15-30							
Stainless steel < 200 HB	HM	65-100	0.02-0.04	0.02-0.04	0.02-0.04	0.03-0.06	0.03-0.05	0.03-0.05	0.03-0.06
	HSS	30-65							
Stainless steel > 200 HB	HM	50-65	0.02-0.03	0.02-0.03	0.02-0.03	0.02-0.04	0.03-0.05	0.03-0.05	0.03-0.06
	HSS	15-30							
Grey cast	HM	65-130	0.02-0.03	0.02-0.03	0.02-0.03	0.02-0.05	0.03-0.05	0.03-0.06	0.05-0.08
	HSS	30-65							
Aluminium	HM	200-400	0.02-0.05	0.02-0.05	0.02-0.05	0.02-0.08	0.05-0.1	0.05-0.1	0.05-0.12
	HSS	100-200							
Special alloy material	HM	30-65	0.02-0.03	0.02-0.03	0.02-0.03	0.02-0.04	0.02-0.05	0.02-0.05	0.03-0.06
	HSS	15-30							

$$*IPR = \frac{\text{mm/rev}}{25.4}$$

Requirements and Recommendations:

- Activation speed: 2000 - 5000 RPM
- Coolant filtration (<25µm)
- Clamping: Sealed collet or hydraulic holder
- If there is long chipping and deep counterbores, program the feed cycle so short chips are received
- Minimum coolant pressure: 280 PSI (approximately 19.3 BAR)

Note:

- Cutting data is dependent on irregular surface, machine and workpiece stability.
- For uneven bore edges and critical conditions use the lower cutting values.
- All cutting information = guideline values

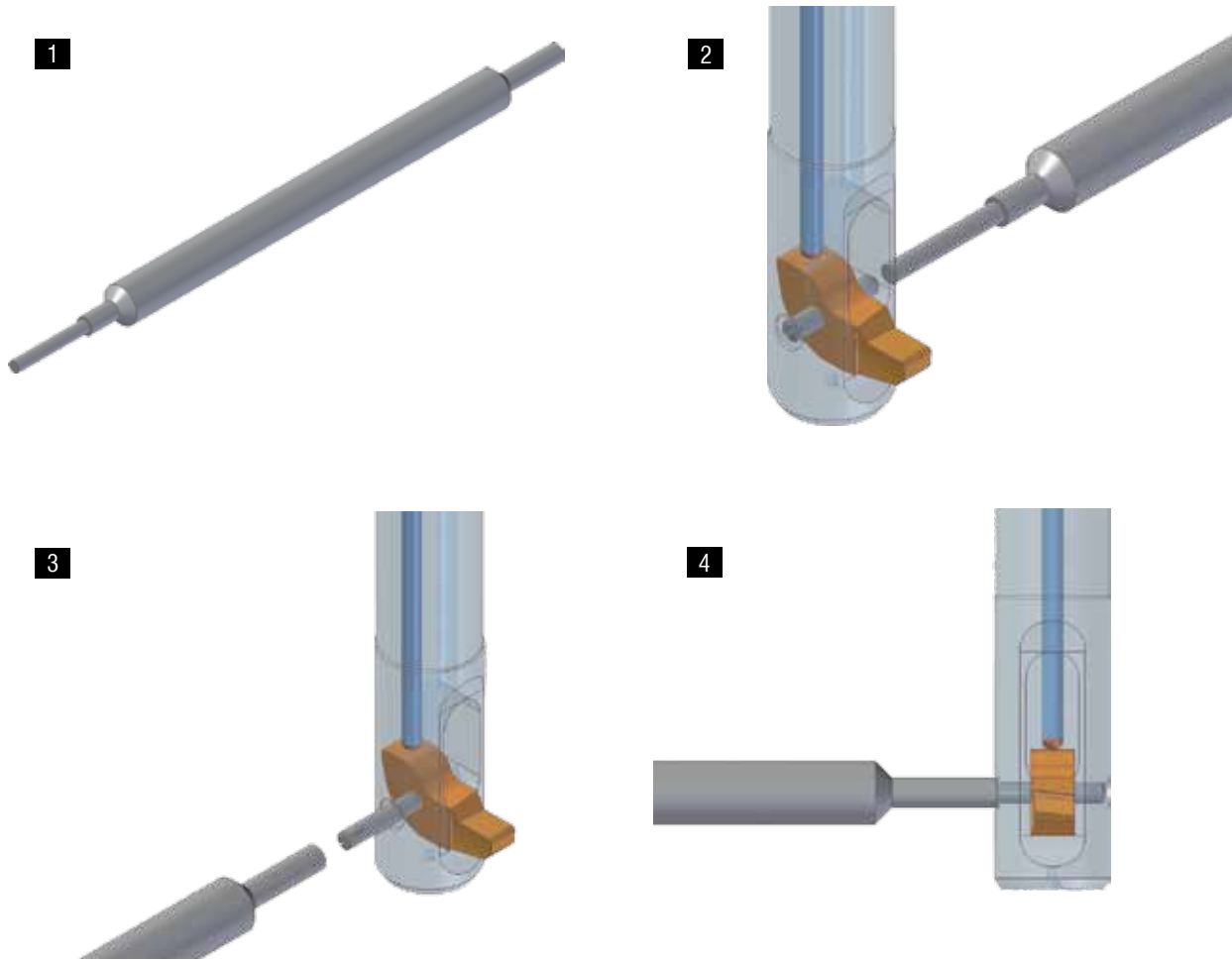

Dismantling

(1) Use the supplied assembly pin for the BSF blade change. (2) Position the assembly pin on the solid end of the split pin (opposite side of the slot). Press the assembly pin in until the split pin falls out and the blade is free.

Assembling

(3) Insert the blade. Then insert the split pin and fix the blade. (4) With the flat side of the assembly pin, push in the split pin until it is flush with the blade housing diameter. Blade is fixed in place.

Note:

The blade must move freely. If it is not, dismantle the blade and repeat the steps listed above. The blade and blade housing must be cleaned and inspected.

After an extended time, check that the blade moves about freely. Dried oil, coolant or dust may cause the blade to stick.

Every time the blade is changed the split pin must be replaced (pin is included in blade shipment). Using a split pin several times may cause blade fixing problems.

Frequently Asked Questions

The blade swings out automatically after the spindle stops (vertical position), is that normal?

Yes. The BSF is designed so the blade swings out automatically. Nevertheless, for machining the recommended activation speed is compulsory.

After running the machine, a counterbore is missing.

Check for correct activation speed and tool position. Check to see if the blade moves freely. Dismount the blade and clean the window of the blade housing and the blade itself. Increase activation speed and/or dwell if necessary. Check to make sure through coolant is off. Replace split pin if necessary.

Does the BSF tool rub the bore surface?

The possibility of rubbing the hole exists due to the single blade design. For critical hole finishes we recommend using a smaller bore diameter (semi-finished bore).

The housing is fixed with 3 clamping screws. Is there a fixing procedure recommended?

No. The housing can be set in any position. Make sure all screws are secure.

Are the housings replaceable?

Yes, each tool size has a different diameter and hole off-set size, housings are not interchangeable between series.

Are sloping surface permitted?

If you are working near a radius area do not use internal coolant until blade is in a full cut. Slow feeds and speeds accordingly.

Caution must be taken
on interrupted cuts

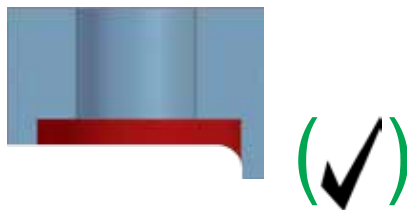

Fully interrupted cut (nut, groove, etc.)
not possible.



Note:

Pay special attention to the recommended bore hole tolerance (+0.1). Bores with a bigger tolerance can cause undesirable results (tool is rubbing in the bore, reduced counterbore diameter etc.) Watch the tool collision diameter (counterbore diameter + 2 mm) when you store the tool in the tool magazine.



Grinding may produce hazardous dust. To avoid adverse effects, use adequate ventilation and read MSDS. Cutting tools may break during use. To avoid injury, use proper safety precautions and protective equipment. Use the machine tool with sufficient rigidity and horsepower. Use a cover on a machine tool and protector, such as glasses, against shattering chips and broken tools due to misuse. Do not use insoluble oil because there is a danger of causing fire.



Visit our website for our full line
of product brochures and videos

www.HeuleTool.com

We provide online tool selectors for the
COFA, **SNAP**, **DEFA** and **BSF** product groups.

Simply enter your application information and the correct tool will
be provided complete with order number and sample drawing.

We are also available on:



SOLO



Automatic Front & Back Counterbore and Spotfacing Tool

- No Anti-rotation device or stop block are required
- Suitable for all CNC, transfer, dial and multi-spindle machines
- Easy handling, Quick change blade system, Modular Set-up
- Excellent ratio of price and performance

As a worldwide leader in tool development, HEULE introduces SOLO, an easy-to-use front and back spotfacing and formsinking tool. The SOLO tool functions reliably without an anti-rotation device, change of spindle rotation, coolant pressure or contact mechanism. The SOLO tool is immediately ready for operation on any machine (CNC, transfer, multi-spindle or conventional machine).

The completely closed tool design (tool head) prevents any coolant contamination. In addition, the pin driven cutting blade, which moves in and out radially, prevents chips from jamming the system.

Simple to Use

Each SOLO Tool is modular and comes with quick change cutting blades that can be changed without removing the tool from the machine. A common tool head can accommodate any configuration of pilot housings and cutting blade configurations.

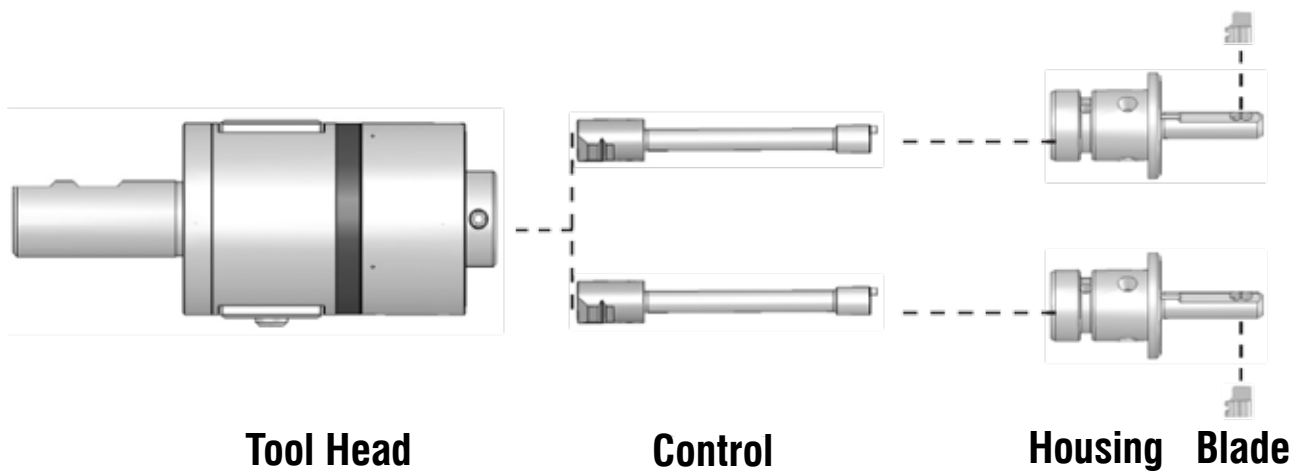

Strong Durable Design

The nature of back counterboring tends to be an unstable and difficult operation due to the large chip force and small pilot hole to counterbore size. Heule tools have proven to be the strongest automatic back boring tool on the market able to cut the most difficult materials and counterbore geometry. Our tools cut on center and are designed to use the maximum pilot size allowed; this helps guarantee stability even in deep hole applications. Experience with difficult applications demonstrates that our unique cutting blade geometry far surpasses other back counterbore tools in strength and reliability. Unlike the flip out back boring systems, HEULE's patented pin drive system activates the cutting blade radially, which prevents chips from interfering with the tool's operation. Keyed blades with no sharp corners and smooth transitions add strength to both the housing and the cutting blade.



How Does It Work?

There are two different models of the SOLO tool, the SOLO 1900 and the SOLO 2. Each tool is capable of reaching counterbore sizes two times the bore diameter minus 1mm. Possible applications up to 30mm through hole. (Max ratio = $\varnothing dx2 - 1mm$).

The **SOLO 1900** uses two centrifugal weights installed in a sealed tool head. With an activation speed rate of 1900 rpm, the weights start moving outwards and turn the gearwheel. The gearwheel drives the blade out by rotating the blade control. When the spindle is stopped, a pull back spring pushes the centrifugal weights back to the center and retracts the blades.

The **SOLO 2** uses similar parts, but works in the opposite way. With an activation speed rate of 2000 rpm or higher, the blades retract when the centrifugal weights move. When the spindle rotation is below 1500 RPM, the weights are pushed back to the center and the blade is fixed in the cutting position. *Optional: SOLO S2, a larger SOLO head (blue ring) may be used for bores larger than approximately 22mm, contact Heule Tool Engineering.*

Example: SOLO 2

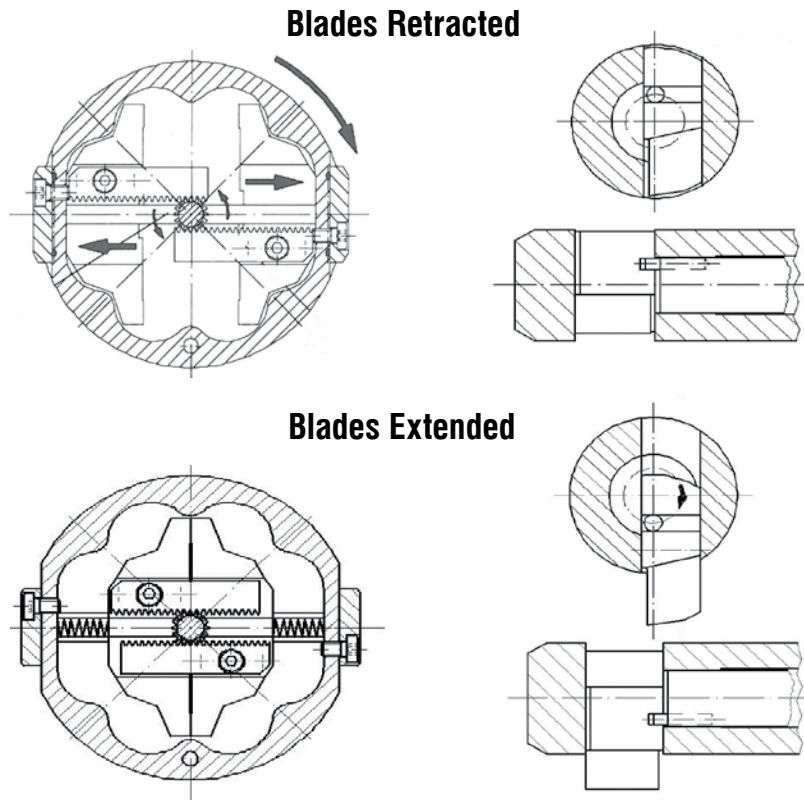

Custom Tooling Options

Each tool is designed and built to our customers specifications. We will always manufacture the strongest tool possible and stand behind the quality of our product.

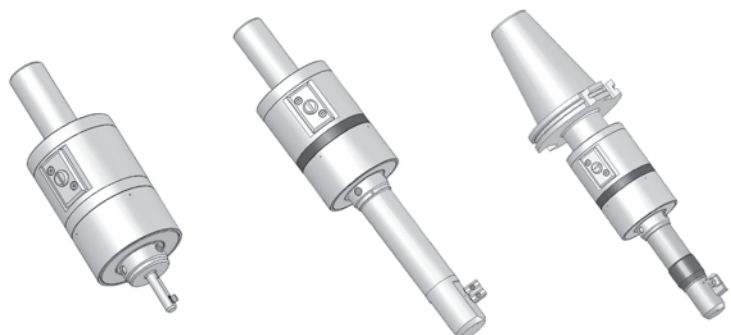

Why Choose Solo

“Solo is the most reliable and strongest Automatic Back Counterbore on the market...”

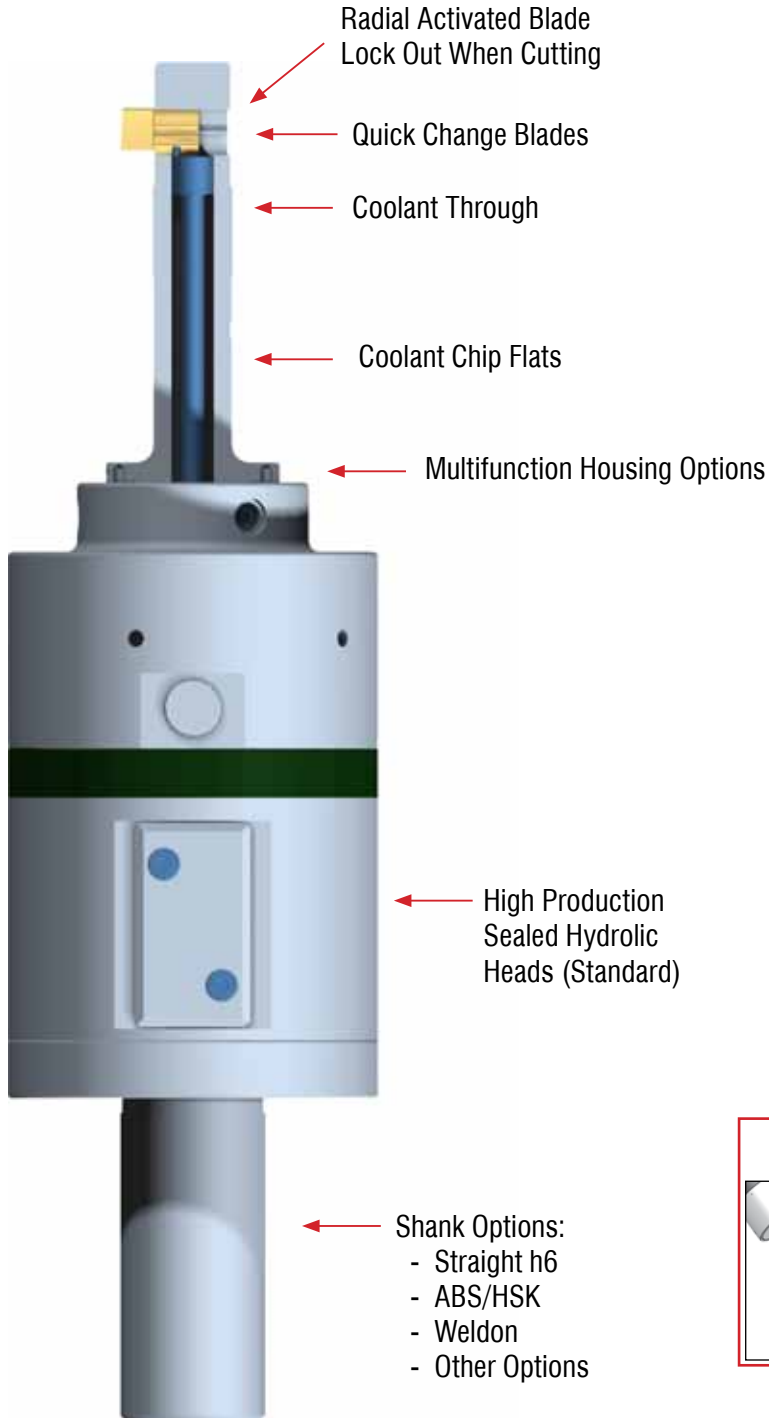

Sample Blade Configurations

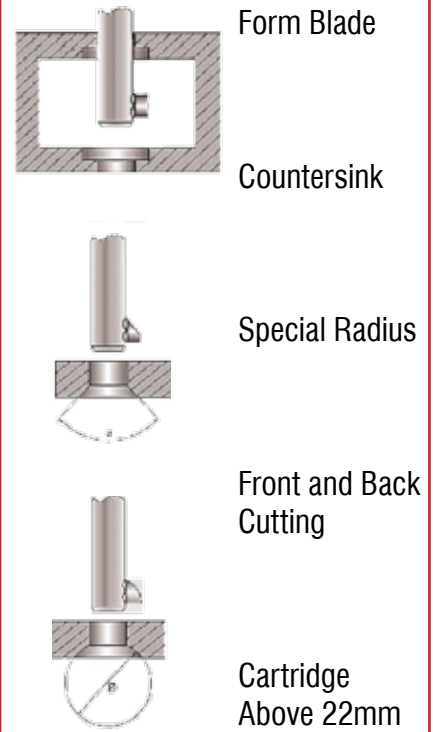

Sample Housing Options

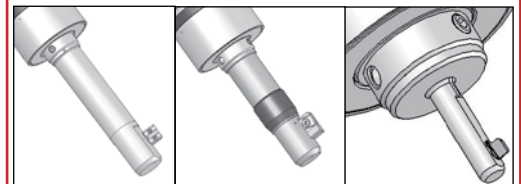

How to Order:

HEULE's SOLO back counterboring tool consists of two major components:

1. Standard TOOL HEAD with integral shank
2. Custom Components; Cutting BLADE (or Cartridge with indexable insert), HOUSING and CONTROL.

- 1) **TOOL HEAD** - This tool head is of standard design and is the base element for all applications with bore diameters 8 to 30mm.
- 2) **Special Components** - Housing pilots, control mechanism and cutting blades are optimized per the desired back bore application and are Design & Build items to suit the needs of our customers. Heule will always manufacture the strongest tool possible and stand behind the quality of our product. Simply submit the **SOLO DATA SHEET** (pg 215) with your application information for our engineering team to review. With each order, approval prints will be supplied to the end user within one week of order.

SOLO Tooling Multi-Operations

The SOLO Tooling system is completely customizable and can be engineered to create multiple features in one tool. Options include indexable inserts, form countersinks and more. All tooling has the capability of through spindle coolant (up to 30 BAR). The coolant holes come from the center of the shank and are diverted through the outer jacket back through the housing to the blade window. For extreme ratios or small housing diameters (typically below 10mm) through coolant to the housing, not the blade is possible. Other options include integral shanks, extra long reach and cartridge style (above hole Ø22mm).

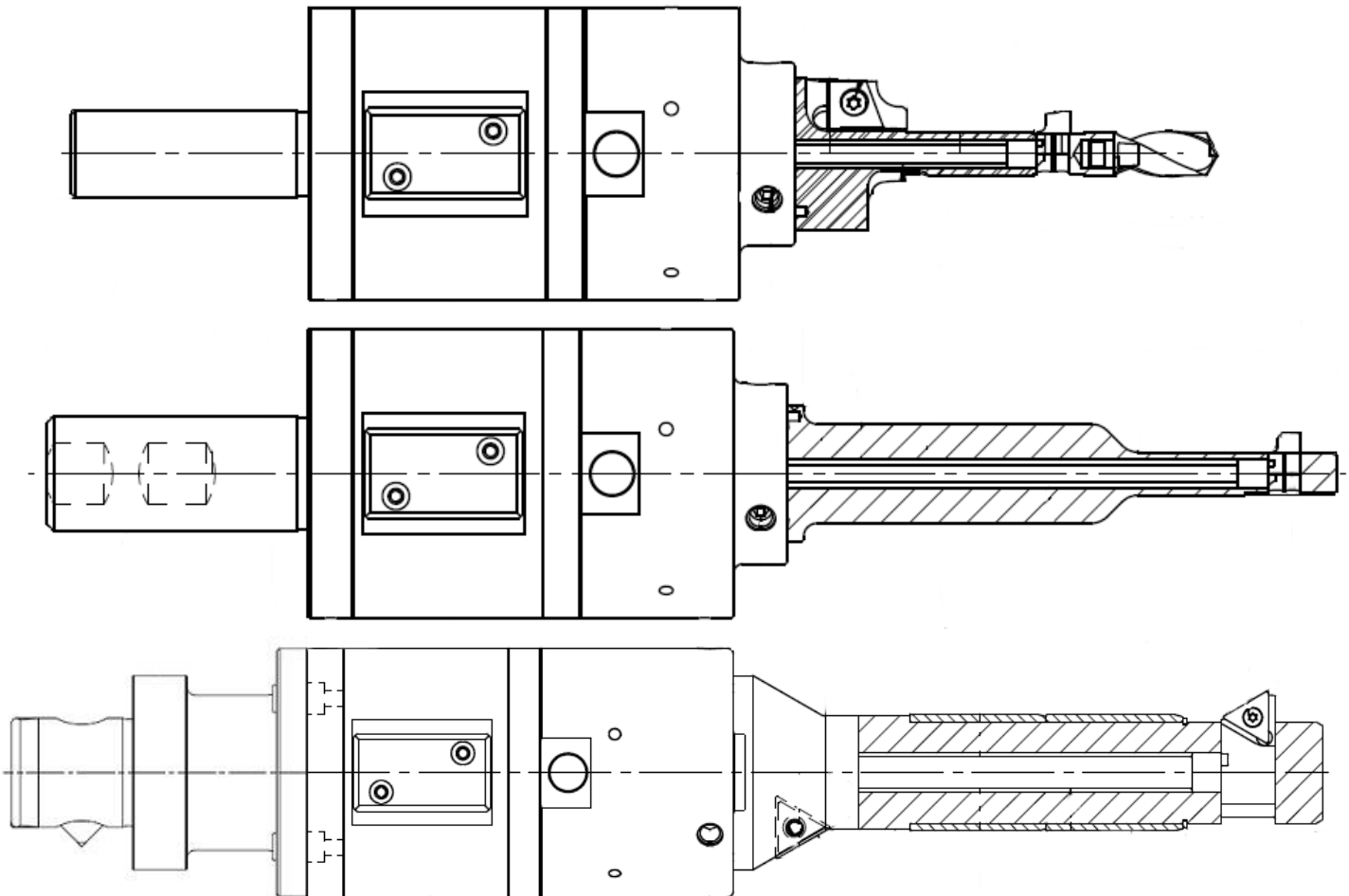

SOLO 1900 (Black Ring) Programming Information

Attention: Pay attention to the speed rate of your tool head. The blade will move out sooner than the tool rated but cutting should only be made at or above the rated speed.

1. With no spindle rotation, pass through the workpiece (blade is retracted)
EV = Fwd Feed.
2. Activate spindle in normal clockwise rotation (blade will extend within rated head speed. (BLACK=1900 RPM)
3. Dwell a minimum 1 second to allow insert to fully extend.
4. Turn coolant on.
5. Back feed and machine your workpiece. AR = Working Feed
6. Travel out of work piece. EV = Forward Feed.
7. Turn coolant off.
8. Spindle Stop, speed rate: 0 (blade will retract).
9. Dwell minimum of 1-2 seconds.
10. With stopped spindle, retract the tool from the workpiece (blade is retracted: speed rate is 0). ER = Rapid Back Feed.

IMPORTANT: Do not run dry! Coolant supply to the blade must be adequate. Do not exceed 3000 RPM or with unstable, unbalanced tool holder.

Material	Speed <small>Surface footage are recommendations only; Remember you must run the minimum of your rate Tool Head (reduce for interrupted cuts).</small>	Feed (IPR) <small>Based on bore ϕd : Counterbore ϕD ratio $Rt = \phi D / \phi d$</small>	
		<small>Rt < 1.6</small>	<small>Rt > 1.6</small>
Aluminum	600-800	.004-.008	.0020-.0030
Stainless Steel	140-300	.003-.005	.0008-.0015
Titanium	60-180	.001-.003	.0008-.0015
Inconel	40-90	.001-.002	.0007-.0012
Cast Iron	260-400	.004-.007	.0010-.0025
Carbon Steel	210-350	.003-.006	.0010-.0020

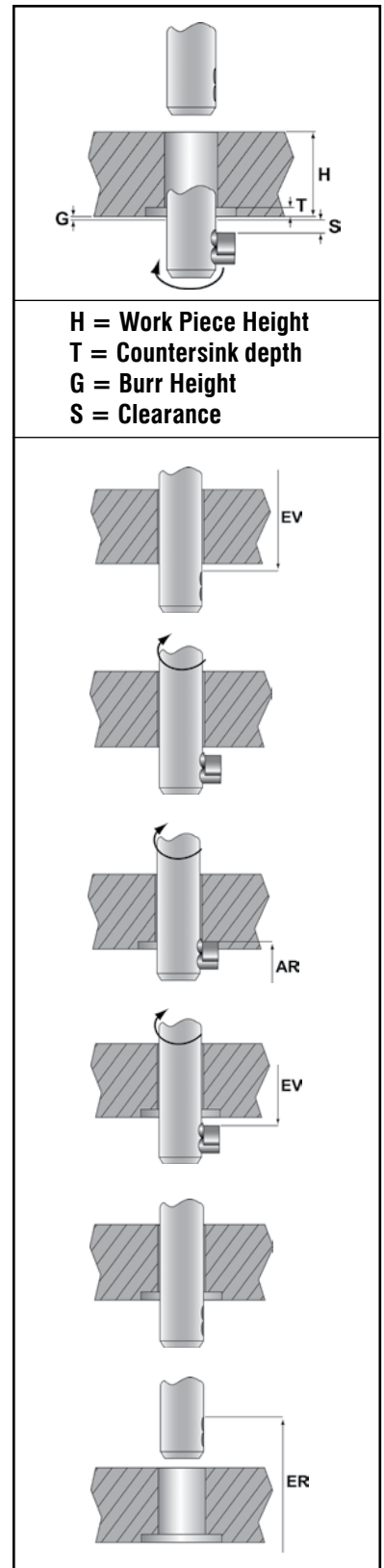

SOLO 2 (Green Ring) Programming Information

Attention: The SOLO 2 works opposite of the SOLO 1900. The cutting blade is always active until the spindle reaches 2000 RPM. Please remain under 1500 RPM (Green Ring) when cutting.

1. With 2000 RPM spindle rotation, pass through the workpiece (blade is retracted). EV = Forward Feed. (Dwell if necessary).
2. Slow spindle down to 200 RPM or stop spindle (blade will extend).
3. Dwell a minimum of 1 second to allow insert to fully extend.
4. Activate spindle to working speed in normal clockwise rotation (max 1500RPM).
5. Turn coolant on.
6. Back Feed and machine your workpiece. AR = Working Feed.
7. Travel out of workpiece. EV = Forward Feed.
8. Turn coolant off.
9. Increase spindle speed >2000 RPM, speed ratio: min 2000 RPM (blade will retract).
Note: Countersinks above 30mm, min 2400 RPM
10. Dwell minimum 1-2 seconds.
11. With spindle rotating at 2000 RPM retract the tool from the work piece (blade is retracted; speed rate is min 2000). ER = Rapid Back Feed.

IMPORTANT: Do not run dry! Coolant supply to the blade must be adequate. Do not exceed 3000 RPM or with unstable, unbalanced tool holder.

Material	Speed Surface footage are recommendations only; Remember you must run the minimum of your rate Tool Head (reduce for interrupted cuts).	Feed (IPR) Based on bore $\varnothing d$: Counterbore $\varnothing D$ ratio $Rt = \varnothing D / \varnothing d$	
		$Rt < 1.6$	$Rt > 1.6$
Aluminum	600-800	.004-.008	.0020-.0030
Stainless Steel	140-300	.003-.005	.0008-.0015
Titanium	60-180	.001-.003	.0008-.0015
Inconel	40-90	.001-.002	.0007-.0012
Cast Iron	260-400	.004-.007	.0010-.0025
Carbon Steel	210-350	.003-.006	.0010-.0020

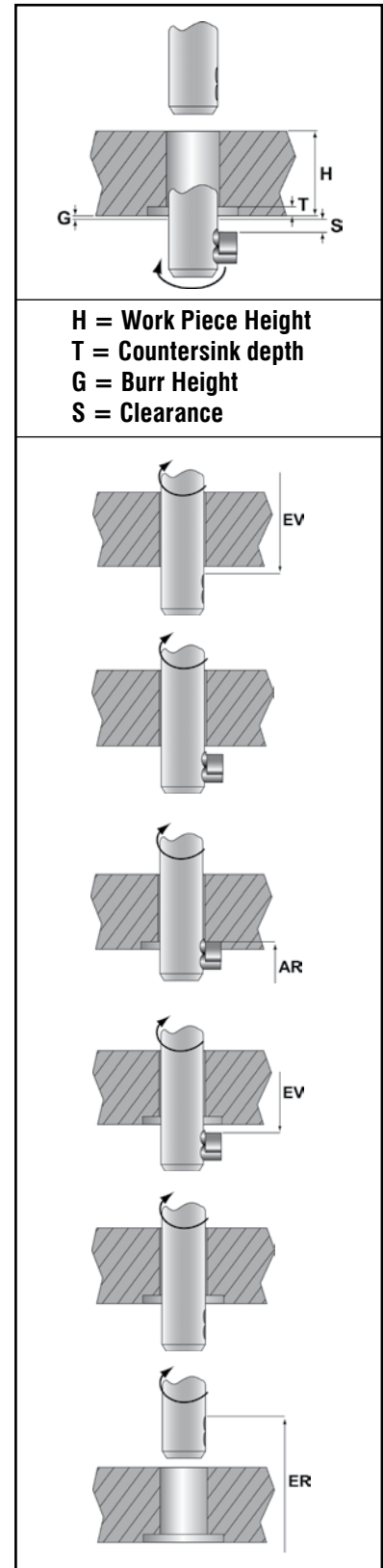

Changing the Blades (Black & Green Rings)

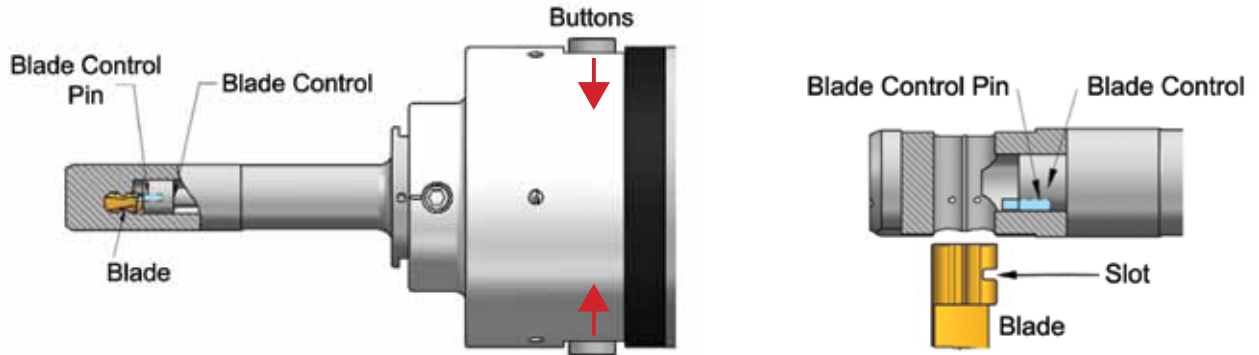

Dismantling of blade:

By pressing the compression buttons at the tool head the blade control with the blade control pin are pulled back. The blade is released and can be pushed out. Keep the compression buttons pressed until the blade is completely removed.

Insertion of blade:

By pressing the compression buttons at the side of the tool head the blade control with blade control pin is pulled back. Keep the compression buttons pressed until the blade is inserted. Insert blade flush with blade window (Black Ring) or insert blade in the blade window in the cutting position (Green Ring). Compression buttons can be released. The control pin must line up with the slot of the cutting blade.

Dismantling Housing and Control

Loosen the 3 clamping screws at the tool head with M3 Hex wrench. Pull the blade housing forward, away from the tool head using the smaller end of the SOLO Disassembly KEY. Then pull blade control forwards away from the tool head. **DO NOT TWIST** or use Vise Grips that would bend or damage Control.

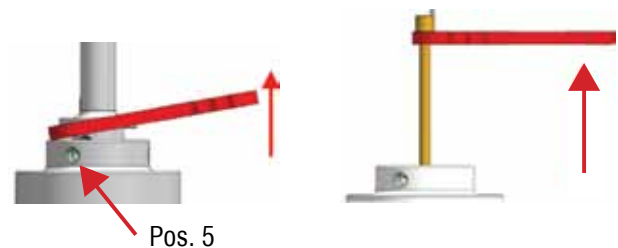

Pos. 5

Assembly and Check Blade Function

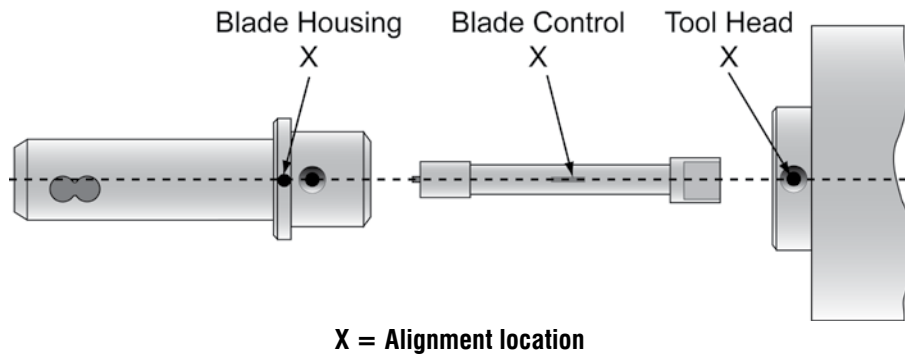

Assembly:

Assemble the blade control by lining up alignment marks (X), press control with slight force into the tool head until the control engages.

Mount blade housing (do not tighten screws) on the tool head making sure the position pin is over the clearance slot and perform a tool function blade check.

Check:

To CHECK the tool function (extension and retraction of the blade) insert the SOLO key (order number GH-B-X-0103) and turn (Black Ring - Clockwise / Green Ring Counterclockwise). The blade should move in & out. After the blade function test, re-position the housing until the position pin hits the end stop. The housing position mark must line up with the notch mark on the tool head.

Then line up the position notch, tighten clamping screws (Pos. 5) firmly using M3 hex wrench.

Attention: All turns with the SOLO key must be done slowly by hand to detect any interference with the blade. DO NOT USE FORCE.

*If using SOLO S2, order number for SOLO key is GH-X-B-0105

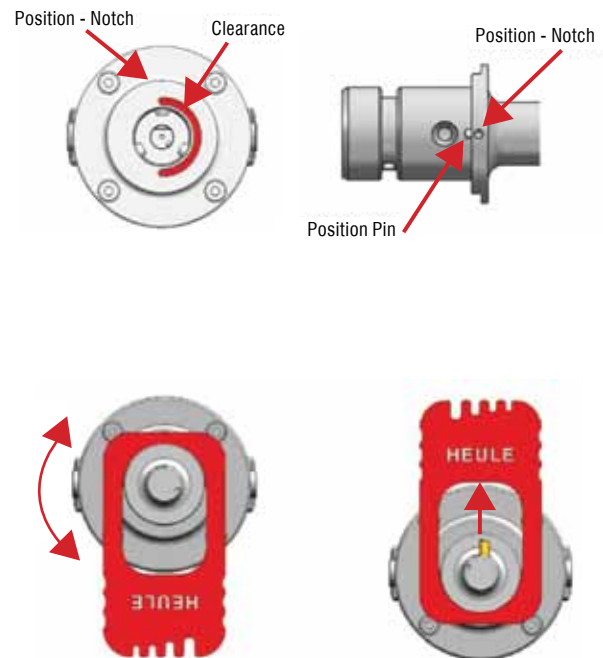



Visit our website for our full line
of product brochures and videos

www.HeuleTool.com

We provide online tool selectors for the
COFA, **SNAP**, **DEFA** and **BSF** product groups.

Simply enter your application information and the correct tool will
be provided complete with order number and sample drawing.

We are also available on:



GH-Z/E



Automatic Front and Back Counterboring Tool for Large Parts

- Rigid locking of blades in cutting position
- No chip interference with blade activation
- Suitable for CNC machines
- Modular tool system

HEULE GH-Z Back Counterboring Tool is the strongest built automated back counterboring tool available on the market today. Used primarily for large part production and turbine industry, Heule's back counterbore tools can be used with any CNC Machining center, conventional and NC mill. The GH-Z back counterbore tooling is capable of producing forward and reverse spotfaces and counterbores as well as special form countersinks and other contour forms. Each tool is design and built to meet customer's specific needs and requirements.

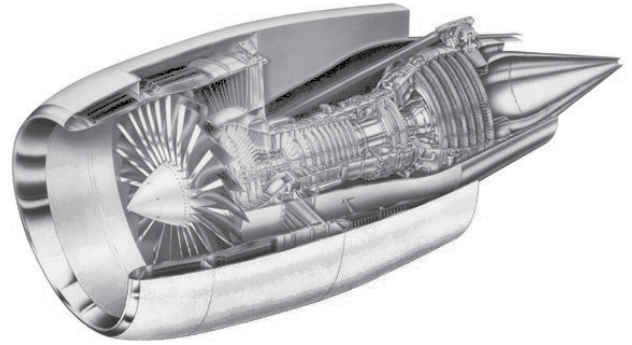

Modular Cutting Tool with Coolant Through

Each GH-Z Reverser System is modular and is available with coolant through the center. Each unit consists of a tool head, control, housing and cutting blade or Cassette with indexable cutting inserts. There are three standard tool heads with weldon shanks. V-tapers adaptations or other precision HSK or ABS shanks are optional. The housing, control and cutting blade configuration is designed specifically for each hole and counterbore application to guarantee the strongest tool possible.

Balance Rigid Tooling

Cutting forces are distributed throughout the complete blade window guaranteeing an optimal balance cutting tool. Close tolerance tooling and balance force distribution adds stability and additional cutting capacity. Size and finish are maintained throughout each operation by the keyed blade cartridge system. No flip out or centrifugal force is used, which creates a reliable tool.

Large Ratio Cuts

Counterbore sizes are capable of reaching 2 times the bore diameter minus 1mm in almost any material and part configuration. Close tolerance insert cartridge holders and housing pockets have proven to add rigidity for exceptional surface finishes even in interrupted cuts. Large ratios require a single cutter for added stability.

GH-Z = 2 effective cutters

GH-E = single cutter

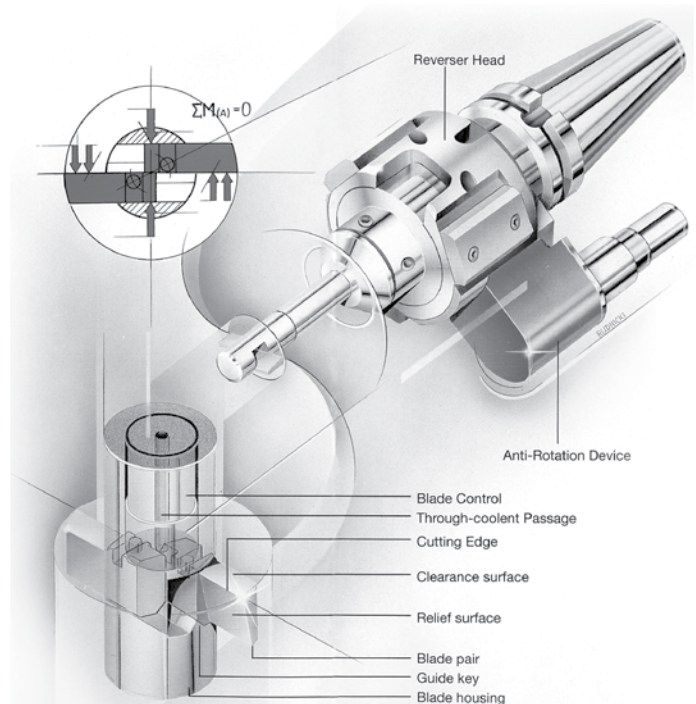

How Does It Work?

The compact tool head contains the mechanical control for blade activation. The integrated braking system, which is fixed by the anti-rotation device to the machine, guarantees a defined position of the blades. Depending on spindle rotation, the cutting blades will extend or retract perpendicular to the bore axis. Pass through the bore with counterclockwise rotation. After the blades pass beyond the workpiece and any side wall, activate the spindle clockwise. The blades extend automatically. Feed back into the work piece to counterbore depth, push out of the bore and reverse the spindle to retract the cutting blades. The back spotface is now finished.

Typical Parts

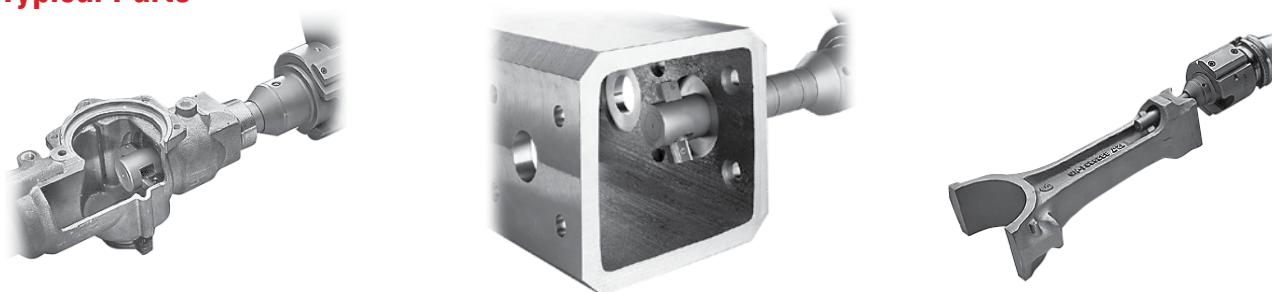

Tool Description

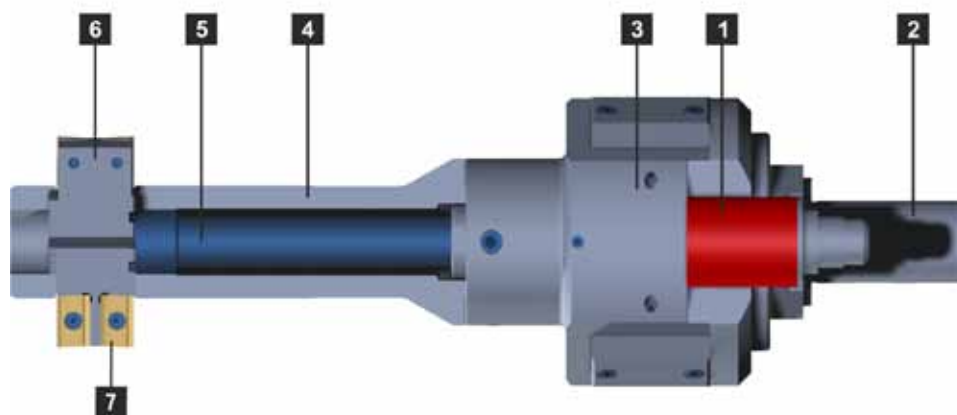

- 1 ARD
- 2 Shank
- 3 Tool Head
- 4 Housing
- 5 Control
- 6 Cartridge
- 7 Blade or Insert

How to Select a Tool

Each tool is built to the needs and requirements of the customer. Typical variables to consider: Counterbore ($\varnothing D$) to hole ($\varnothing d$) ratio (Max 2x hole diameter minus 1mm (0.040")), in process hole diameter and tolerance, over all tool length, interrupted cut or weldments, material quality, machine or part rigidity, surface finish, cast surfaces or machined surface. Tooling options may include manual or automated tool changer (ARD) arm, guide & wear bushings, and front & back cutters.

Please note large ratios and difficult applications require a single blade or cartridge cutter for added stability. The tool head is modified to accommodate the single blade application (GH-E).
(Max ratio = $\varnothing d \times 2 - 1\text{mm}$)

Please fill out the application data sheet on page 162 with each application request and include your part print and/or configuration.

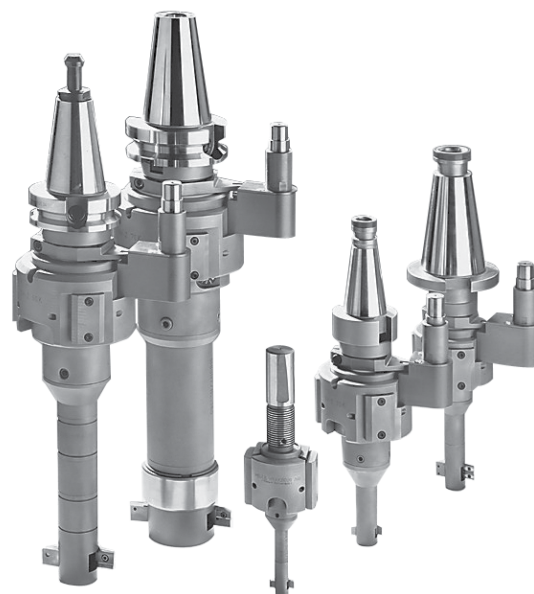

Programming Information

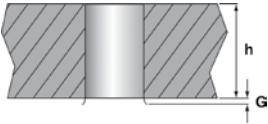
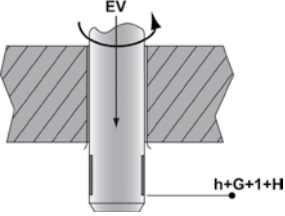
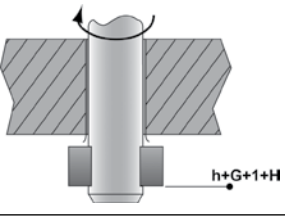
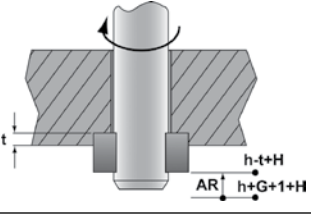
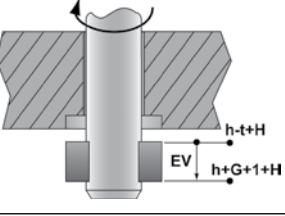
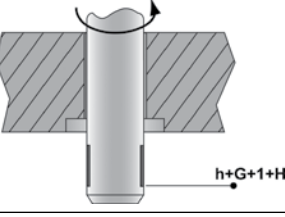
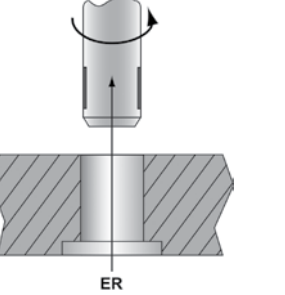
	<p>Step 1: After each tool change the start position of the tool has to be newly defined. This can be achieved by minimum two spindle rotations clockwise and afterwards counter-clockwise. This changeover guarantees the perfect function of the tool. $G = \text{Burr Length}$.</p>
	<p>Step 2: Spindle rotating counter-clockwise passing through the bore with rapid-feed, forwards (blades retracted). $h = \text{Workpiece Height}$ $H = \text{Blade Height}$ $EV = \text{Rapid-feed, forwards}$</p>
	<p>Step 3: Change the direction of the spindle rotation to clockwise (blades extended).</p>
	<p>Step 4: Machine the workpiece with working-feed, backwards. $t = \text{Countersink Depth}$ $AR = \text{Working-feed, backwards (0.05-0.1mm/rev)}$</p>
	<p>Step 5: Travel out of the workpiece with rapid-feed, forwards (direction of spindle rotation: clockwise).</p>
	<p>Step 6: Change the direction of the spindle rotation counter-clockwise (blades retracted). Note: Most machines require a .5 second dwell following step 6.</p>
	<p>Step 7: Withdraw the tool from the workpiece with rapid-feed, backwards. $ER = \text{Rapid-feed, backwards}$.</p>

Programming Information – Feeds and Speeds

The compact tool head contains the mechanical control for blade activation. The integrated braking system, which is fixed by the anti-rotation device to the machine, guarantees a defined position of the blades. Depending on spindle rotation, the cutting blades will extend or retract perpendicular to the bore axis. Pass through the bore with counterclockwise rotation. After the blades pass beyond the workpiece and any side wall, activate the spindle clockwise. The blades extend automatically. Feed back into the work piece to counterbore depth, push out of the bore and reverse the spindle to retract the cutting blades. The back spotface is now finished.

Cutting speeds: Based on twin-bladed cutting tools in the corresponding material and with the equivalent counterbore diameter.

Feed Rate: 0,04 to 0,1 mm/rev. The feed is based on the relation between the counterbore diameter (D) and the bore diameter (d) (as diameter (D) approaches 2x that of diameter (d) – the slower the feed).

Material	Speed Surface footage are recommendations only (reduce for interrupted cuts).	Feed (IPR) Based on bore $\varnothing d$: Counterbore $\varnothing D$ ratio $Rt = \varnothing D / \varnothing d$	
		$Rt < 1.6$	$Rt > 1.6$
Aluminum	260-400	.004-.008	.0020-.0030
Stainless Steel	80-240	.003-.005	.0008-.0015
Titanium	40-120	.001-.003	.0008-.0015
Inconel	15-50	.001-.002	.0007-.0012
Cast Iron	220-340	.004-.007	.0010-.0025
Carbon Steel	180-290	.003-.006	.0010-.0020

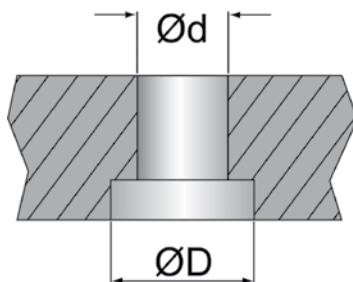



HEULE+

PRECISION TOOLS



Appendix

REFERENCE
MATERIALS

WWW.HEULETOOL.COM

Return to info@heuletool.com

HEULE Application Data Sheet
For Deburring – Chamfering

Interest:

- | | |
|--|---|
| <input type="checkbox"/> Front and Back Deburring | <input type="checkbox"/> Back Only Deburring |
| <input type="checkbox"/> Front and Back Chamfering | <input type="checkbox"/> Back Only Chamfering |
| <input type="checkbox"/> Combination Tooling | <input type="checkbox"/> Front Countersinking |
| <input type="checkbox"/> Back Spotfacing | <input type="checkbox"/> Other _____ |

Information for:

- Purchase Order _____
- Request for Quotation (RFQ)
- Request for Tool Test Approval
- Requesting Technical Help
- Date Needed:**
- By _____
- Urgent

Company Name: _____

Date: _____

Contact Name: _____

Phone: _____

Address: _____

Fax: _____

Email: _____

City: _____ **State:** _____ **Zip:** _____

Problem Description: (Please specify any issues and include drawing or part print)

Part Configuration: (Fill in values that apply):

REF: Part name/Drawing number: _____

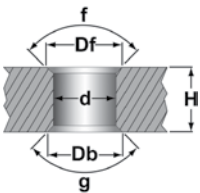

- Straight Hole
Deburring/Chmf.

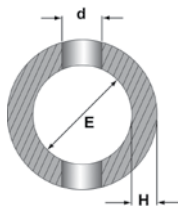

- Tube or I.D.
Deburring

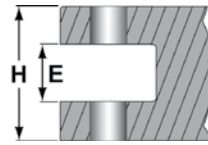

- Inline Holes
Deburring/Chmf.

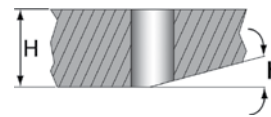

- Irregular
Surface

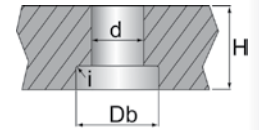

- Back
Counterboring

d = _____ + _____ f = _____

Df = _____ + _____ g = _____

Db = _____ + _____ h = _____

H = _____ i = _____

E = _____ **Surface**
Finish Req. = _____

In Process Hole Size: _____

Material: _____ **Hardness:** _____

Production (Yr.): _____ **Cycle Time:** _____

Sequence (1, 2, 3, etc.):

Drill Bore Tap

Ream Deburr/Chmf.

Other Information/Sketch:

Machine Type: _____

Shank Size: _____

Feed Unit: _____ **Hydrl.** _____ **Pneum.** _____ **Elec.**

Back Feed Control? Y or N **Interrupted Cuts/Cross Holes? Y or N**

Return to info@heuletool.com

Heule Tool Application Data Sheet
For Countersinking – Counterboring – Spotfacing

Information for:

Purchase Order _____

Request for Quotation (RFQ)

Request for Tool Test Approval

Requesting Technical Help

Date Needed:

By _____

Urgent

Interest:

Back Counterboring	Back Countersink
Front and Back Counterboring	Front and Back Countersink
Back Spotfacing	
Front and Back Spotfacing	Other _____

Company Name: _____	Date: _____
Contact Name: _____	Phone: _____
Address: _____	Fax: _____
_____	Email: _____
City: _____ State: _____ Zip: _____	

Application Description: (Please specify any issues and include drawing or part print)

Part Configuration: (Fill in values that apply):

REF: Part name/Drawing number: _____

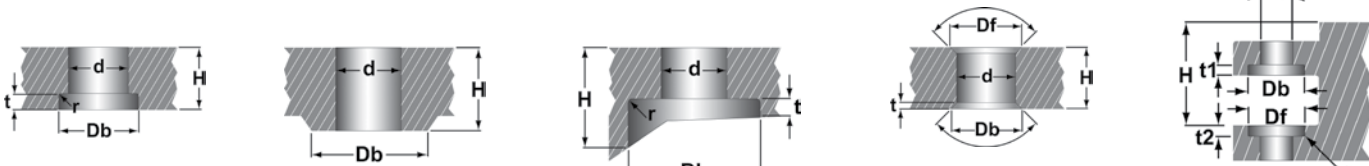

- Back Counterboring Back Spotfacing Interrupted Back C'bore Back/Front Countersink Front/Back Counterbore

Ød = _____ +/- _____ a° = _____

ØDb = _____ +/- _____ b° = _____

ØDf = _____ +/- _____ t1 (depth) = _____

H = _____ t2 (depth) = _____

r = _____

Surface Finish required: _____

Material: _____	Hardness: _____
Production (Yr.): _____	Cycle Time: _____
Sequence (1, 2, 3, etc.):	
<input type="checkbox"/> Drill <input type="checkbox"/> Bore <input type="checkbox"/> Tap	
<input type="checkbox"/> Ream <input type="checkbox"/> C'bore/sink	

Other Information/Sketch:

Machine Type: _____

Shank Size: _____

Feed Unit: _____ Hydrl. _____ Pneum. _____ Elec. _____

Back Feed Control? Y or N **Interrupted Cuts/Cross Holes?** Y or N

Heule Tool Application Data Sheet
For Drilling

Company Name: _____	Date: _____
Contact Name: _____	Phone: _____
Address: _____	Fax: _____
City: _____ State: _____ Zip: _____	Email: _____

Application Data

Part No.: _____	Description: _____	Workpiece Material: _____
Hardness: _____	Print (Yes or No): _____	Surface Quality of Workpiece: _____
Required Hole Surface Finish: _____	Hole Diameter Tolerance: _____	Position of Workpiece: _____
Hole Description: <input type="checkbox"/> Blind <input type="checkbox"/> Through <input type="checkbox"/> Pre-Drilled <input type="checkbox"/> Interrupted <input type="checkbox"/> Cast Hole Actual Size: _____ Hole Depth: _____		
<input type="checkbox"/> Single Pass <input type="checkbox"/> Multiple Pass <input type="checkbox"/> Reamed Hole <input type="checkbox"/> Threaded Hole	Sketch:	Chip Form: 

Machine Data

Drilling Info.: _____	Tool Holder: _____	Spindle RPM Range: _____
Drilling Angle: _____	Coolant Available (Yes or No): _____	<input type="checkbox"/> Through Spindle <input type="checkbox"/> External
Coolant Pressure: _____	Coolant Flow: _____	Compressed Air: _____
Type of Coolant: <input type="checkbox"/> Soluble Oil <input type="checkbox"/> Cutting Oil <input type="checkbox"/> Synthetic	Type of Tool Holder: _____	Bushing (Yes or No): _____
Distance to Workpiece: _____	Current Type of Cutting Tool in Use: <input type="checkbox"/> HSS <input type="checkbox"/> Inserted <input type="checkbox"/> Carbide <input type="checkbox"/> Other: _____	
Flute Style: <input type="checkbox"/> Fast <input type="checkbox"/> Standard <input type="checkbox"/> Slow <input type="checkbox"/> Other: _____		

Present Data

No. of Parts to be Machined (Month/Year): _____	No. of Holes Per Part: _____	Surface Footage (SFM): _____
Spindle Speed (RPM/SFM): _____	Feed (IPR/mm/u): _____	Feed (IPR/MPM): _____
Index Time: _____	Cut Time: _____	Tool Change Time: _____
No. of Holes Per Grind: _____	No. of Grinds Available Per Tool: _____	No. of Tools to Produce Job: _____

Objective







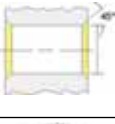

<input type="checkbox"/> Increase Holes Per Tool	<input type="checkbox"/> Shorten Process Time	<input type="checkbox"/> Improve Hold Finish	<input type="checkbox"/> Eliminate 2nd Operation
<input type="checkbox"/> Combine Drilling/Deburring	<input type="checkbox"/> Cut Multi-Diameter Holes in One Pass	<input type="checkbox"/> Other: _____	

Explanation:

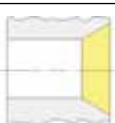
Material Description	W - Nr. German	DIN - German	AIS/SAE - USA
Low Carbon Steel	1.0035	St 33	1010
	1.0038	RSt 37-2	1045
	1.0401	C 15	1015
	1.0050	St 50-2	1050
Alloy Steel	1.0501	Ck 35 V	1035
	1.1141	Ck 15	1115
	1.5732	14 NiCr 14	3415
	1.7225	42 CrMo 4 G	4140
Tool Steel	1.1221	Ck 60	1060
	1.3505	100 Cr 6	52100
	1.7225	42 CrMo 4	4140
	1.5141	53MnSi 4	-
Alloy Tool Steel	1.1191	Ck 45 V	4140
	1.7225	42 CrMo 4	4142
	1.2080	X 210 Cr 12	D3
	1.7220	CS-34 CrMo 12	4135
Alloy Cast Steel	1.6582	34 CrNiMo 6	4340
	1.8159	50 CrV4	6150
	1.2367	X 38 CrMoV 5 3	A2
	1.7361	32 CrMo 12	4145
Stainless Steel	1.4006	X 10 Cr 13	403
	1.4057	X 22 CrNi 12	431
	1.4034	X 40 Cr 13	420
	1.4005	X 12 CrS 13	416
Stainless Steel – Austenitic, Martensitic	1.4300	X 12 CrNi 18 8	302
	1.4301	X 5 CrNi 18 9	304 (304H)
	1.4435	X 2 CrNiMo 18 12	316
	1.4542	X 10 CrNiMoTi 18 12	17-4 ph
Grey Cast Iron	0.6010	GG-10	A48-20B
	0.6015	GG-15	A48-25B
	0.6020	GG-20	A48-30B
Cast Iron Malleable	0.6025	GG-25	A48-35B
	0.8135	GTS-35	A48-40B
	0.8140	GTS-40	A48-45B
	0.7050	GGG-50	80-55-06
Copper Alloys	2.0331	CuZn 36 Pb 1.5	B121
	2.0401	CuZn 36 Pb 3	B121
	2.1030	CuSn 8	B103
	2.0920	CuAl 8	CuAl 8
Aluminum Alloys	3.2582.05	GD-ALSi 12	383.2 (ALSi0120)
	3.3541.01	G-ALMg 3	514.0 (ALMg 3)
	3.2315	ALMgSi 1	413.0 (ALMgSi 1)
	3.0205	Al 99	1200 AL 99

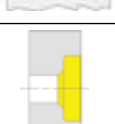
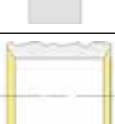
HTC015

Metric	Inch	Metric	Inch	Metric	Inch	Metric	Inch	Metric	Inch	Metric	Inch
2.0	0.079	8.0	0.315	14.0	0.551	20.0	0.787	26.0	1.024	32.0	1.260
2.1	0.083	8.1	0.319	14.1	0.555	20.1	0.791	26.1	1.028	32.1	1.264
2.2	0.087	8.2	0.323	14.2	0.559	20.2	0.795	26.2	1.032	32.2	1.268
2.3	0.091	8.3	0.327	14.3	0.563	20.3	0.799	26.3	1.036	32.3	1.272
2.4	0.095	8.4	0.331	14.4	0.567	20.4	0.803	26.4	1.040	32.4	1.276
2.5	0.099	8.5	0.335	14.5	0.571	20.5	0.807	26.5	1.044	32.5	1.280
2.6	0.102	8.6	0.339	14.6	0.575	20.6	0.811	26.6	1.047	32.6	1.283
2.7	0.106	8.7	0.343	14.7	0.579	20.7	0.815	26.7	1.051	32.7	1.287
2.8	0.110	8.8	0.346	14.8	0.583	20.8	0.819	26.8	1.055	32.8	1.291
2.9	0.114	8.9	0.350	14.9	0.587	20.9	0.823	26.9	1.059	32.9	1.295
3.0	0.118	9.0	0.354	15.0	0.591	21.0	0.827	27.0	1.063	33.0	1.299
3.1	0.122	9.1	0.358	15.1	0.594	21.1	0.831	27.1	1.067	33.1	1.303
3.2	0.126	9.2	0.362	15.2	0.598	21.2	0.835	27.2	1.071	33.2	1.307
3.3	0.130	9.3	0.366	15.3	0.602	21.3	0.839	27.3	1.075	33.3	1.311
3.4	0.134	9.4	0.370	15.4	0.606	21.4	0.843	27.4	1.079	33.4	1.315
3.5	0.138	9.5	0.374	15.5	0.610	21.5	0.846	27.5	1.083	33.5	1.319
3.6	0.142	9.6	0.378	15.6	0.614	21.6	0.850	27.6	1.087	33.6	1.323
3.7	0.146	9.7	0.382	15.7	0.618	21.7	0.854	27.7	1.091	33.7	1.327
3.8	0.150	9.8	0.386	15.8	0.622	21.8	0.858	27.8	1.094	33.8	1.331
3.9	0.154	9.9	0.390	15.9	0.626	21.9	0.862	27.9	1.098	33.9	1.335
4.0	0.157	10.0	0.394	16.0	0.630	22.0	0.866	28.0	1.102	34.0	1.339
4.1	0.161	10.1	0.398	16.1	0.634	22.1	0.870	28.1	1.106	34.1	1.343
4.2	0.165	10.2	0.402	16.2	0.638	22.2	0.874	28.2	1.110	34.2	1.346
4.3	0.169	10.3	0.406	16.3	0.642	22.3	0.878	28.3	1.114	34.3	1.350
4.4	0.173	10.4	0.409	16.4	0.646	22.4	0.882	28.4	1.118	34.4	1.354
4.5	0.177	10.5	0.413	16.5	0.650	22.5	0.886	28.5	1.122	34.5	1.358
4.6	0.181	10.6	0.417	16.6	0.654	22.6	0.890	28.6	1.126	34.6	1.362
4.7	0.185	10.7	0.421	16.7	0.657	22.7	0.894	28.7	1.130	34.7	1.366
4.8	0.189	10.8	0.425	16.8	0.661	22.8	0.898	28.8	1.134	34.8	1.370
4.9	0.193	10.9	0.429	16.9	0.665	22.9	0.902	28.9	1.138	34.9	1.374
5.0	0.197	11.0	0.433	17.0	0.669	23.0	0.906	29.0	1.142	35.0	1.378
5.1	0.201	11.1	0.437	17.1	0.673	23.1	0.909	29.1	1.146	35.1	1.382
5.2	0.205	11.2	0.441	17.2	0.677	23.2	0.913	29.2	1.150	35.2	1.386
5.3	0.209	11.3	0.445	17.3	0.681	23.3	0.917	29.3	1.154	35.3	1.390
5.4	0.213	11.4	0.449	17.4	0.685	23.4	0.921	29.4	1.157	35.4	1.394
5.5	0.217	11.5	0.453	17.5	0.689	23.5	0.925	29.5	1.161	35.5	1.398
5.6	0.220	11.6	0.457	17.6	0.693	23.6	0.929	29.6	1.165	35.6	1.402
5.7	0.224	11.7	0.461	17.7	0.697	23.7	0.933	29.7	1.169	35.7	1.406
5.8	0.228	11.8	0.465	17.8	0.701	23.8	0.937	29.8	1.173	35.8	1.409
5.9	0.232	11.9	0.469	17.9	0.705	23.9	0.941	29.9	1.177	35.9	1.413
6.0	0.236	12.0	0.472	18.0	0.709	24.0	0.945	30.0	1.181	36.0	1.417
6.1	0.240	12.1	0.476	18.1	0.713	24.1	0.949	30.1	1.185	36.1	1.421
6.2	0.244	12.2	0.480	18.2	0.717	24.2	0.953	30.2	1.189	36.2	1.425
6.3	0.248	12.3	0.484	18.3	0.720	24.3	0.957	30.3	1.193	36.3	1.429
6.4	0.252	12.4	0.488	18.4	0.724	24.4	0.961	30.4	1.197	36.4	1.433
6.5	0.256	12.5	0.492	18.5	0.728	24.5	0.965	30.5	1.201	36.5	1.437
6.6	0.260	12.6	0.496	18.6	0.732	24.6	0.969	30.6	1.205	36.6	1.441
6.7	0.264	12.7	0.500	18.7	0.736	24.7	0.972	30.7	1.209	36.7	1.445
6.8	0.268	12.8	0.504	18.8	0.740	24.8	0.976	30.8	1.213	36.8	1.449
6.9	0.272	12.9	0.508	18.9	0.744	24.9	0.980	30.9	1.217	36.9	1.453
7.0	0.276	13.0	0.512	19.0	0.748	25.0	0.984	31.0	1.220	37.0	1.457
7.1	0.280	13.1	0.516	19.1	0.752	25.1	0.988	31.1	1.224	37.1	1.461
7.2	0.283	13.2	0.520	19.2	0.756	25.2	0.992	31.2	1.228	37.2	1.465
7.3	0.287	13.3	0.524	19.3	0.760	25.3	0.996	31.3	1.232	37.3	1.469
7.4	0.291	13.4	0.528	19.4	0.764	25.4	1.000	31.4	1.236	37.4	1.472
7.5	0.295	13.5	0.531	19.5	0.768	25.5	1.004	31.5	1.240	37.5	1.476
7.6	0.299	13.6	0.535	19.6	0.772	25.6	1.008	31.6	1.244	37.6	1.480
7.7	0.303	13.7	0.539	19.7	0.776	25.7	1.012	31.7	1.248	37.7	1.484
7.8	0.307	13.8	0.543	19.8	0.780	25.8	1.016	31.8	1.252	37.8	1.488
7.9	0.311	13.9	0.547	19.9	0.783	25.9	1.020	31.9	1.256	37.9	1.492

Key Words	Part Configuration	Typical Call-Out	Material	COFA	SNAP-GHS	SNAP-DEFA	DEFA	SOLO	GH-Z/E	VEX-S	Important Limits/Comments
Common Deburr		Break edge .005 - .015"	Any; Rc<28	●	●	✓	✓	■	■	●	SNAP tooling is quick and simple
			Any; Rc>28	●	▲	✓	●	■	■	■	COFA with 10° cutting blades on flat surfaces is ideal for break edge; DEFA for large burr formation
Angle Call-out		Deburr .010x45°	Any; Rc<28	X	●	✓	✓	▲	▲	●	SNAP tooling is quick and simple
			Any; Rc>28	X	▲	✓	●	▲	▲	■	DEFA is the best solution for harder to cut material or large burr formations
Tube/I.D. Deburr		Break edge .005 - .015"	Any; Rc<28	●	▲	X	X	▲	▲	▲	Use standard COFA tooling up to 1:2 (hole:cross hole) SNAP tooling up to 1:5 or use SNAP 60° blades up to 1:4
			Any; Rc>28	●	■	X	X	▲	▲	■	COFA is ideal for common break edge
Large Back Countersinks		Back Countersinks over 0.060"	Any; Rc<28	X	X	▲	▲	●	●	X	SOLO or GH-Z/E tooling with special blades Use DEFA if possible
			Any; Rc>28	X	X	▲	▲	●	●	X	SOLO or GH-Z/E tooling
Tap/Thread		Deburr Tap hole; Chamfer over Major Diameter	Any; Rc<28	■	●	✓	●	▲	▲	●	Best choice is standard SNAP tool with large enough SNAP blade
			Any; Rc>28	■	■	●	●	▲	▲	■	Over 28Rc DEFA may be the best choice
Back Counterbore		Back Counterbore	Any; Rc<28	X	X	X	X	●	●	X	SOLO is your choice; above 1" holes consider GH-Z/E
			Any; Rc>28	X	X	X	X	●	●	X	SOLO is your choice; above 1" holes consider GH-Z/E
Large Bore		Deburr Bores larger than 1"; up to 6"	Any; Rc<28	●	✓	●	▲	X	■	X	Use HEULE Cassettes
			Any; Rc>28	●	✓	●	▲	X	■	X	Use HEULE Cassettes
Interference		Deburr close to interruption	Any; Rc<28	■	✓	■	■	✓	✓	■	Check with HEULE - Need Special Blades with clearance
			Any; Rc>28	■	✓	■	■	✓	✓	■	Check with HEULE - Need Special Blades with clearance
Deep Hole Deburring		Deburr deep holes	Any; Rc<28	●	●	▲	▲	■	■	X	Extended tool may be required
			Any; Rc>28	●	●	▲	▲	■	■	X	Possible cassette application
Deburring Snap Grooves		Break edge .005 - .015"	Any; Rc<28	●	✓	X	X	X	X	X	Possible application for Heule's special penetration deburr tooling
			Any; Rc>28	●	X	X	X	X	X	X	X

NOTE: The above information is for reference only; please contact Heule Tool Corp for application specific tooling.

- = Best Choice
- ✓ = Recommended
- ▲ = Possible Solution
- = Available
- X = Will not work

A large grid area for taking notes, with a faint watermark reading "SWISS MADE" in the lower right portion of the grid.

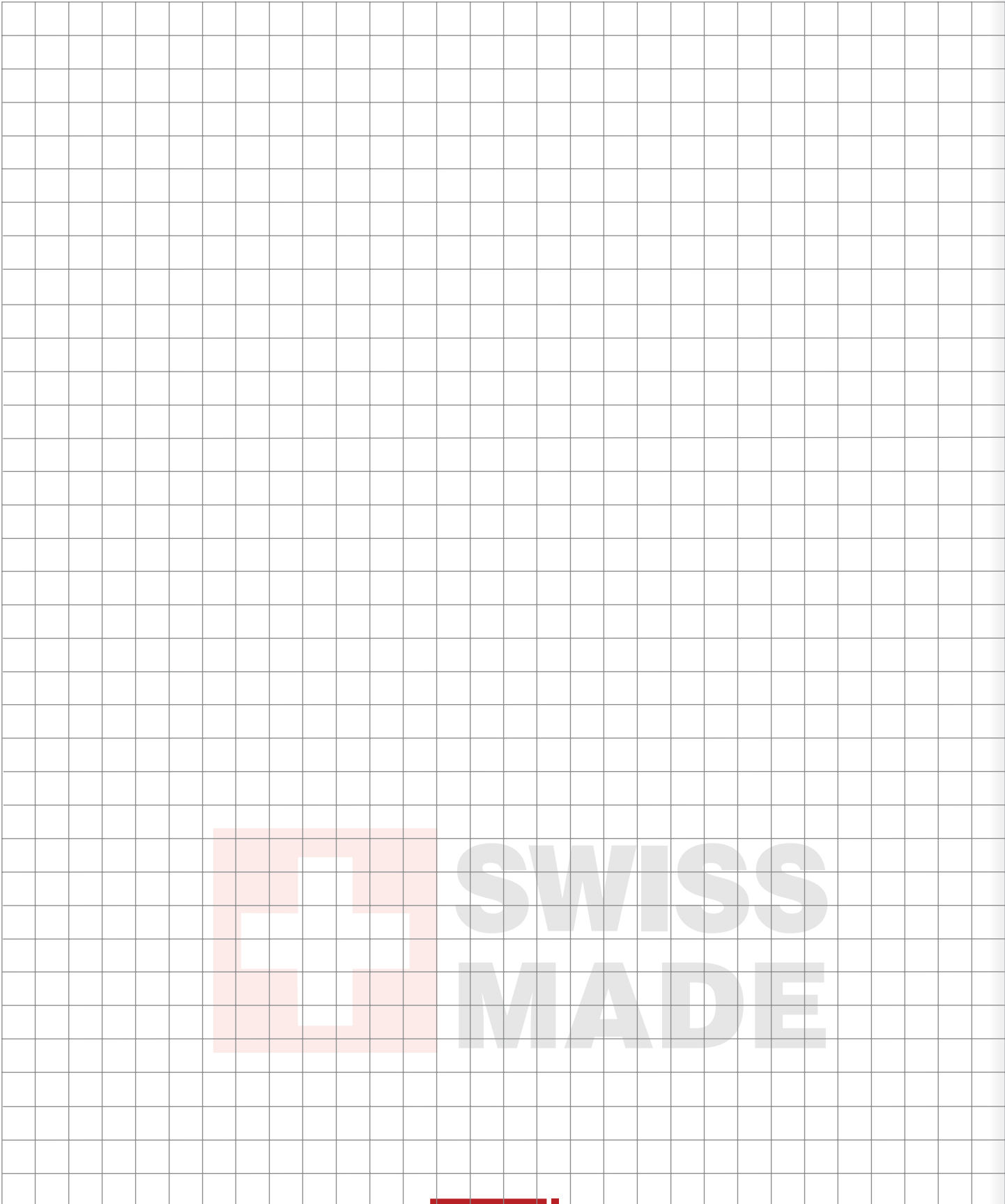

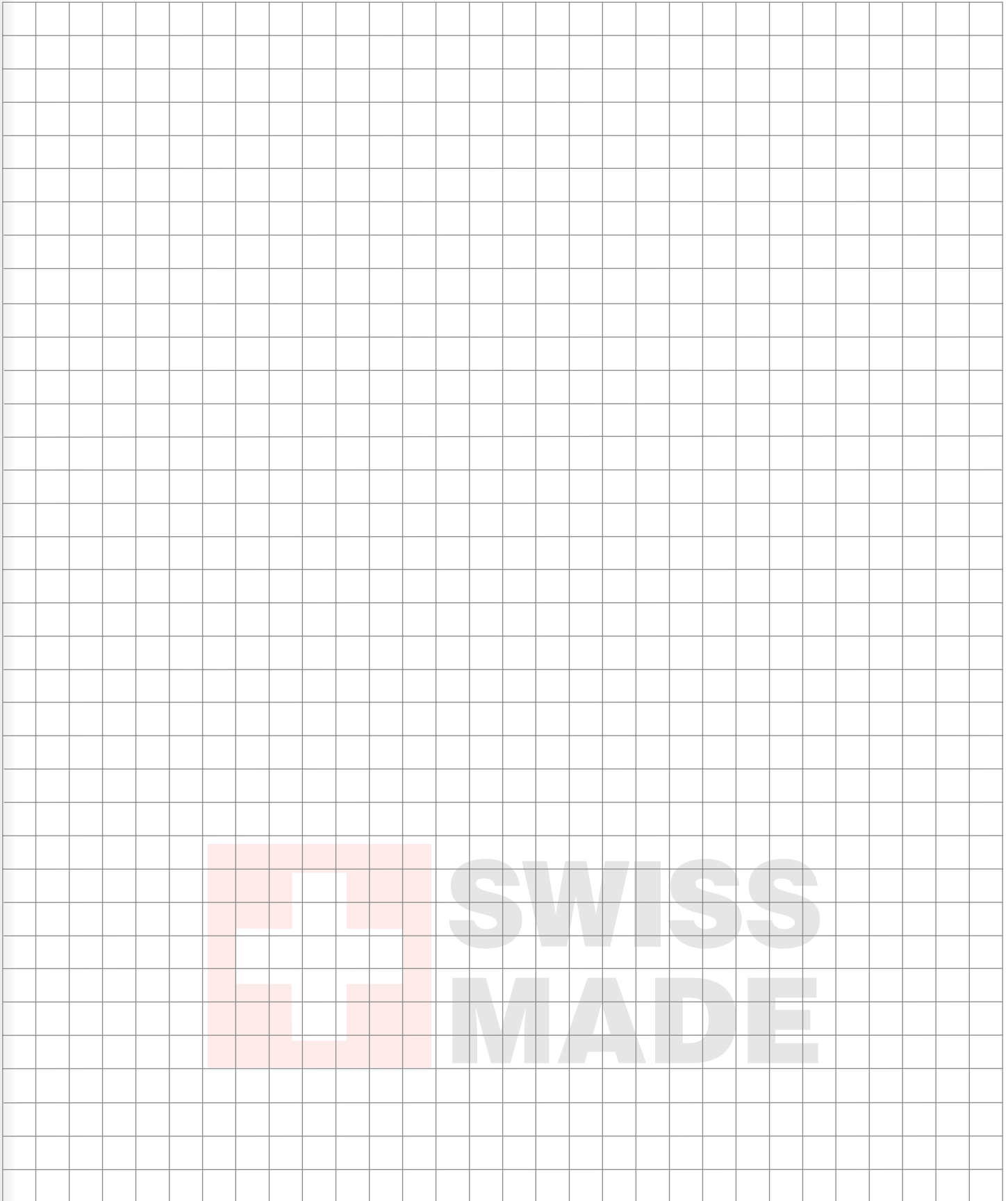

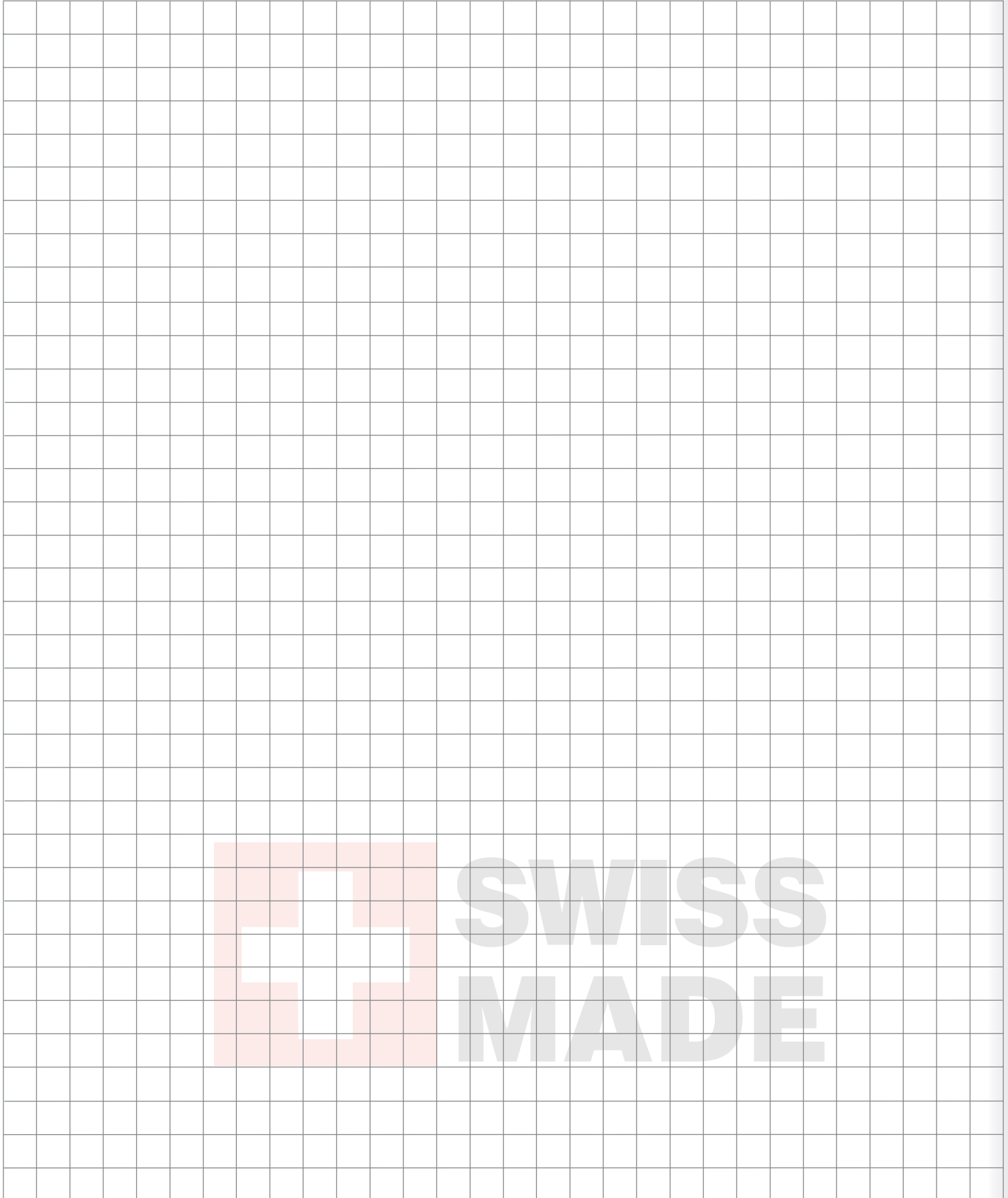

A large grid area for taking notes, with a faint watermark reading "HEULE+ SWISS MADE" in the lower center.

A large grid of graph paper for taking notes, consisting of 20 columns and 30 rows of small squares. A faint watermark logo is visible in the lower-left quadrant of the grid, and the text 'SWISS MADE' is printed in large, light grey letters in the lower-right quadrant.

A large grid area for taking notes, with a faint watermark reading "SWISS MADE" in the lower right portion of the grid.

Celebrating **50** Years *in the* **CUTTING TOOL INDUSTRY**

The Quality Leader in Through-Hole Deburring, Chamfering and Countersinking



1961 Heule, a Swiss based company, was started by Heinrich Heule. Originally starting in a home cellar, Heule created deburring and back boring tools which soon captured the German Automotive Manufactures.



1988 With such great success in Europe, Heule opened a subsidiary in USA in 1988 to support a growing need for specialized quality deburring and back boring tools.

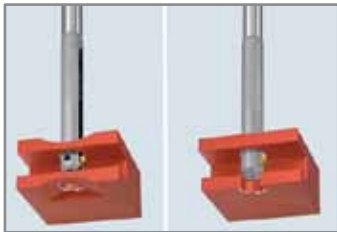

Present Heule now sells in over 48 countries to the leaders in the automotive and aerospace industry. Heule continues their global presence with offices in Switzerland, USA, Korea and China.

"Heule Tool thanks you for over 50 great years of continued support. We look forward to surpassing your expectations again with our innovative technology in the future!"

*Gary Brown
North American President*



"We got the consistency we needed to keep our production going, AND saw a \$45,000/yr savings in time and labor."

HEULE+
PRECISION TOOLS

"We saved over \$60,000 just by eliminating a second machining operation."

For Product Videos and Brochures visit www.HeuleTool.com



Over 50 Years of Manufacturing Cutting Tools

HEULE manufactures cutting tools of the highest quality and precision consistent with Swiss craftsmanship for use in the machine tools of some of the world's largest manufacturers; and the smallest machine shops.



CHAMFERING / DEBURRING

COFA
SNAP
GH-S
DEFA

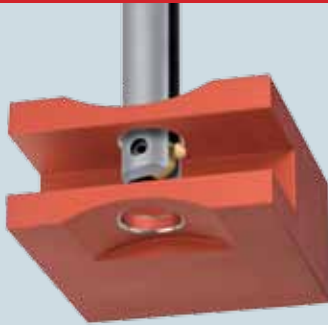

COUNTERSINKING

GH-K
COMP

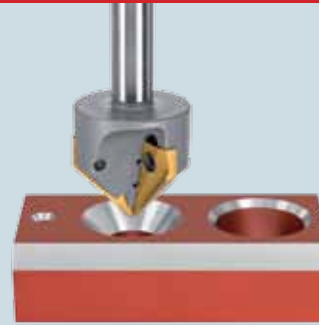

BACK SPOTFACING

BSF
SOLO
GH-Z/E



DRILLING

VEX-P
VEX-S
COMBI



HEULE TOOL CORPORATION
131 Commerce Drive
Loveland, Ohio 45140
USA

Phone (513) 860-9900 Fax
(513) 860-9992 info@heuletool.com
www.heuletool.com

HEULE WERKZEUG AG
Wegenstrasse 11/Postfach
9436 Balgach
Switzerland

Phone +41 71 726 38 38
Fax +41 71 726 38 39
www.heule.com

ISO 9001:2008 Company