



**COMPLETE
METALWORKING
SOLUTIONS**

(800) 991-4225
www.ahbinc.com
ISO Certified
customerservice@ahbinc.com



Milling Catalog

2018/2019





Boehlerit – Pioneer in Carbide Development

The Boehlerit brand was established in 1932 for the carbide production of the Böhler company in Düsseldorf. 1950 was the beginning of carbide production in the Austrian steel town of Kapfenberg where the Boehlerit Group's headquarters are located today. The take-over of the entire Boehlerit Group by the Leitz Group from Oberkochen, Germany in 1991 marked an important milestone in the history of Boehlerit. Since its integration into the Leitz Group, Boehlerit has successfully developed into the group's center for cutting materials. It is one of the world's leading producers of carbide cutting materials for tools for wood, plastic and metal cutting and tools for turning, milling, drilling, bar peeling, steel industry and crankshaft machining.

Carbide for structural parts and wear protection are yet another core competency of Boehlerit.

Synergies with the affiliated company Bilz, the internationally leading producer of tapping chucks, are utilized to the benefit of customers worldwide.

Production sites

The Boehlerit Group sets international quality standards. Every year, the company invests in new production technologies and in the expansion of capacities at its advanced production sites. High-quality products made in Austria, Germany, Spain and Turkey incorporate the latest research and development findings.

Distribution

Together with the Bilz Group and exclusive partners, Boehlerit Group is represented on nearly all continents. Absolute dedication to its customers, swift consulting and supply service and the highest product quality are its core principles. Our highly specialized distribution organizations with more than 300 qualified application consultants and sales engineers live by these principles, and our experienced field staff is always and everywhere on hand nearby to provide consultation and service for any challenge our customers may be faced with.

Research and Development

The Research and Development department of Boehlerit meets the continuously changing demands (increased productivity, improved materials, new applications) that carbide, as a cutting and wear protection material must fulfill. It does so with its advanced analytical methods and in close cooperation with universities and research institutions.

The result of the company's concentration on development are new application-oriented products of the highest quality – made by Boehlerit.

PH HORN PH

boehlerit

Milling



The Boehlerit brand was established in 1932 for the carbide production of the Böhler company in Düsseldorf. 1950 was the beginning of carbide production in the Austrian steel town of Kapfenberg where the Boehlerit Group's headquarters are located today. The take-over of the entire Boehlerit Group by the Leitz Group from Oberkochen, Germany in 1991 marked an important milestone in the history of Boehlerit. Since its integration into the Leitz Group, Boehlerit has successfully developed into the group's centre for cutting materials.

It is one of the world's leading producers of carbide cutting materials for tools for wood, plastic and metal cutting and tools for turning, milling, drilling, bar peeling, steel industry and crankshaft machining.

Carbide for structural parts and wear protection are yet another core competency of Boehlerit.

Synergies with the affiliated company Bilz, the internationally leading producer of tapping chucks, are utilised to the benefit of customers worldwide.

Production sites

The Boehlerit Group sets international quality standards. Every year the company invests in new production technologies and in the expansion of capacities at its advanced production sites. High-quality products made in Austria, Germany, Spain and Turkey incorporate the latest research and development findings.

Distribution

Together with the Bilz Group and exclusive partners, Boehlerit Group is represented on nearly all continents. Absolute dedication to its customers, swift consulting and supply service and the highest product quality are its core principles. Our highly specialised distribution organisations with more than 300 qualified application consultants and sales engineers live by these principles, and our experienced field staff is always and everywhere on hand nearby to provide consultation and service for any challenge our customers may be faced with.

Research and Development

The Research and Development department of Boehlerit meets the continuously changing demands (increased productivity, improved materials, new applications) that carbide, as a cutting and wear protection material must fulfil.

It does so with its advanced analytical methods and in close cooperation with universities and research institutions. The result of the company's concentration on development are new application-oriented products of the highest quality – made by Boehlerit.



Kapfenberg in Styria / AUSTRIA

Overview Tools Milling	4
ISO indexable inserts for milling	
Designation systems	10
Indexable inserts program	12
Milling tools	
Milling cutters 45° for indexable inserts	27
Cutting data recommendations milling 45°	40
Milling cutters 90° for indexable inserts	43
Cutting data recommendations milling 90°	82
3D-milling	85
Cutting data recommendations 3D-milling	102
Solid carbide extensions	105
Technical hints	
Technological advantages milling	110
Grade overview milling	112
Spare parts - Fixation screw	115
Torque wrench®	116
DINA PLUS® torque wrench kit	116
Ramping	117
Formulas	117
Attachment	
Calculation of approach angle w_s	118
Dimensions, units and application formulas	119
Solutions of problems in milling	120
Material comparison chart	121
Sales organisations	128

Milling 45°

Pltec 45N

Ø 50 mm - 250 mm Face Milling Cutter
Insert size 05 and 08

Ø 2" - 10" Face Milling Cutter
Insert size 05 and 08

Page 28

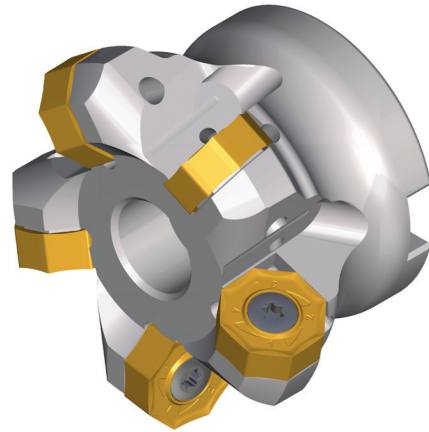

ETAtec 45P Multi Functional

Ø 50 mm - 200 mm Face Milling Cutter
Insert size 04 and (13)

Ø 2" - 8" Face Milling Cutter
Insert size 04 and (13)

Ø 25 mm - 40 mm End Milling Cutter
Insert size 04 and (13)

Ø 25 mm - 40 mm Screw on type
Insert size 04 and (13)

Page 32

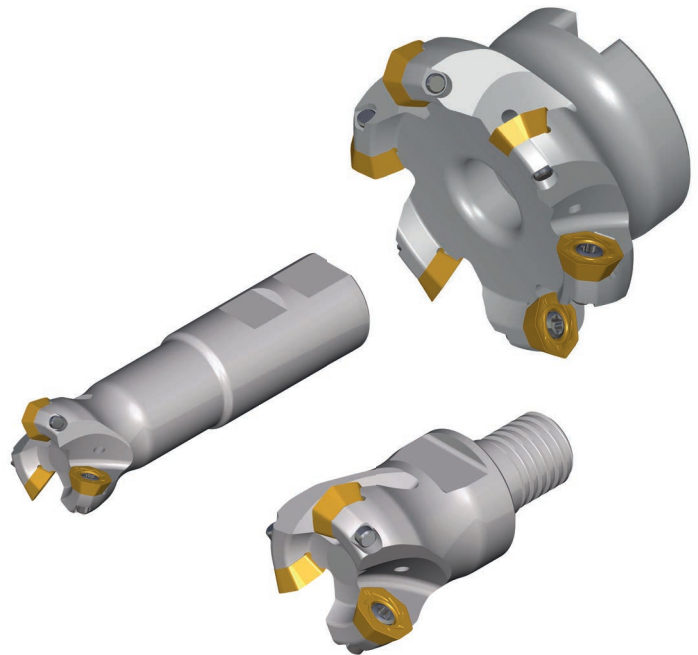

THETAtec 45N

Ø 50 mm - 250 mm Face Milling Cutter
Insert size 12

Ø 2" - 10" Face Milling Cutter
Insert size 12

Page 36

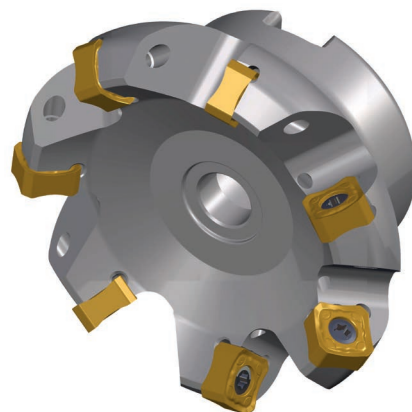

Milling 45°

ISO 45P

Ø 40 mm - 160 mm Face Milling Cutter
Insert size 12

Page 38

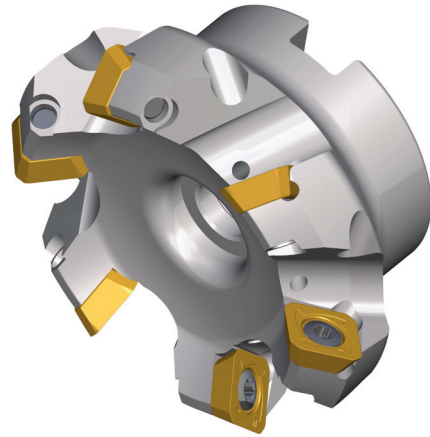

Milling 90°

BETAtec 90P Feed
Multi Functional

Ø 40 mm - 160 mm Face Milling Cutter
Insert size 10 and 18

Ø 1 1/2" - 5" Face Milling Cutter
Insert size 10 and 18

Ø 16 mm - 40 mm End Milling Cutter
Insert size 10 und 18

Ø 1/2" - 1 1/2" End Milling Cutter
Insert size 10 und 18

Ø 16 mm - 40 mm Screw on type
Insert size 10

Page 44

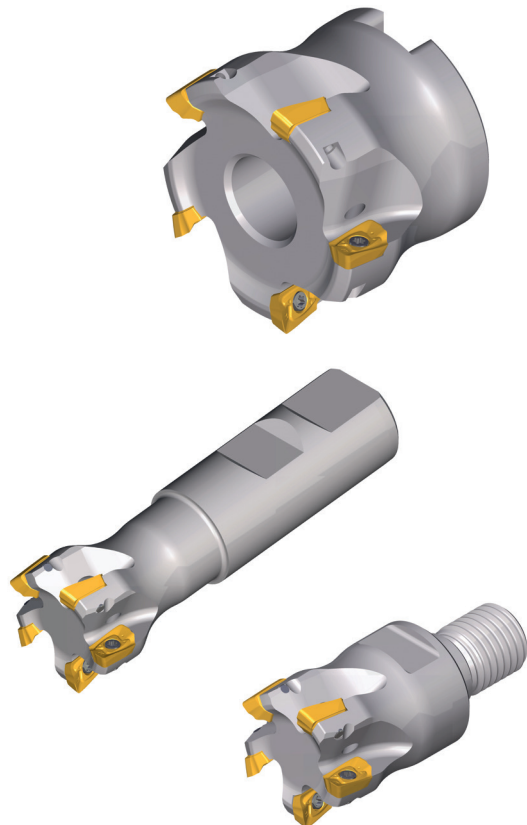

Milling 90°

DELTAtec 90P Feed Multi Functional

Ø 40 mm - 200 mm Face Milling Cutter
Insert size 10, 14 and 18

Ø 1 1/2" - 5" Face Milling Cutter
Insert size 10 and 14

Ø 25 mm - 32 mm End Milling Cutter
Insert size 10

Ø 1" - 1 1/4" End Milling Cutter
Insert size 10

Ø 25 mm - 40 mm Screw on type
Insert size 10

Page 52

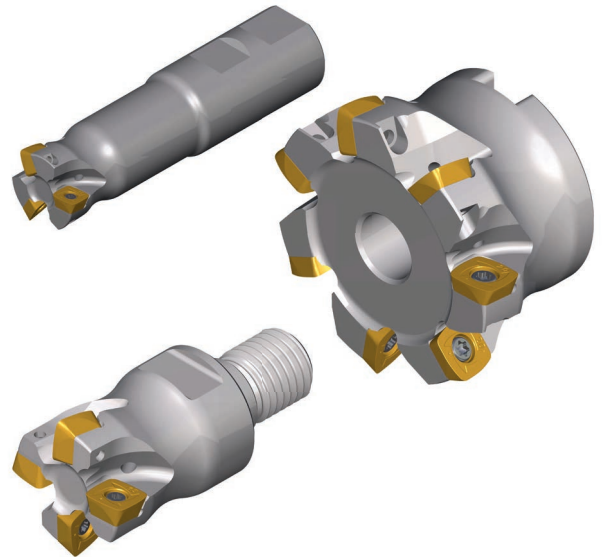

DELTAtec 90N

Ø 40 mm - 160 mm Face Milling Cutter
Insert size 10 and 15

Ø 20 mm - 40 mm End Milling Cutter
Insert size 10 and 15

Page 60

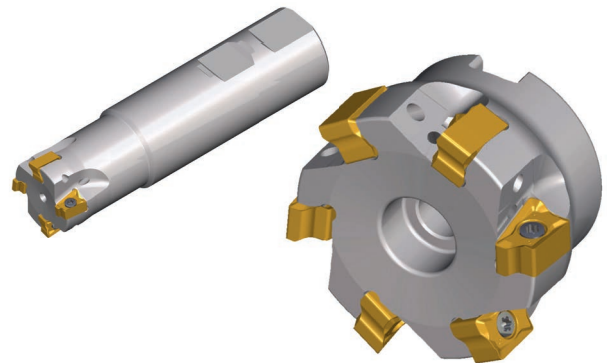

DELTAtec 90N Tang

Ø 50 mm - 315 mm Face Milling Cutter
Insert size 13

Page 64

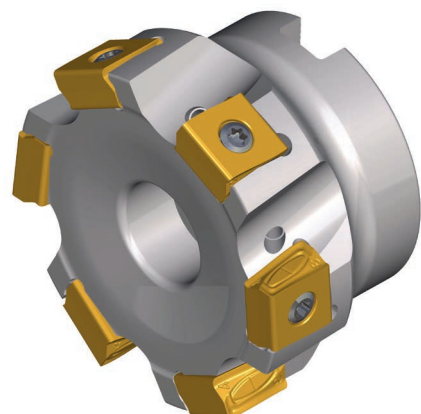

Milling 90°

ISO 90P

Ø 40 mm - 125 mm Face Milling Cutter
Insert size 10 and 16

Ø 1 1/2" - 5" Face Milling Cutter
Insert size 10 and 16



Ø 12 mm - 40 mm End Milling Cutter
Insert size 10 and 16

Ø 1/2" - 1 1/2" End Milling Cutter
Insert size 10 and 16



Ø 16 mm - 32 mm Screw on type
Insert size 10

Page 66

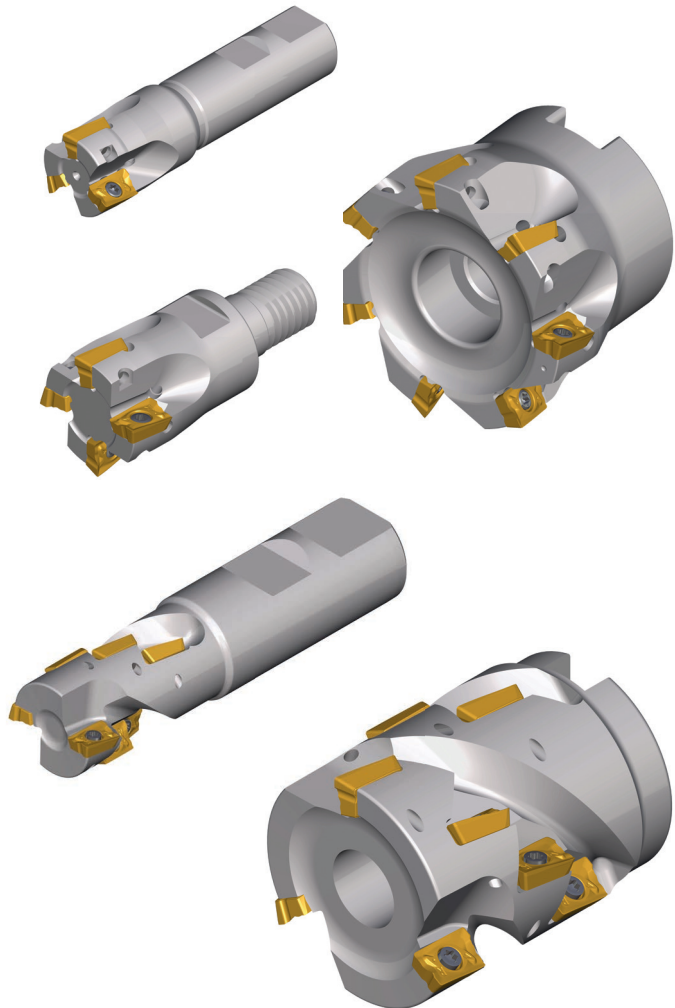

THETAtec 88N

Ø 50 mm - 250 mm Face Milling Cutter
Insert size 12

Page 76

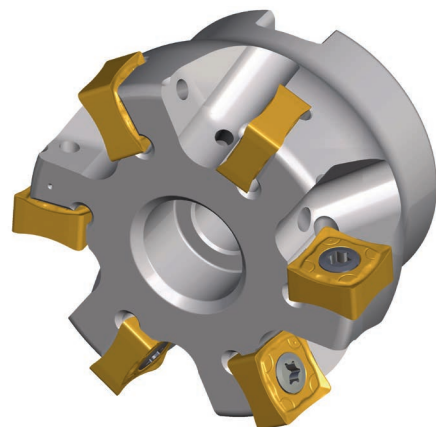

Milling 90°

ZETAtec 90N

Ø 32 mm - 160 mm Face Milling Cutter
Insert size 04 and 08

Ø 2" - 6" Face Milling Cutter
Insert size 08

Ø 20 mm - 32 mm End Milling Cutter
Insert size 04

Page 78

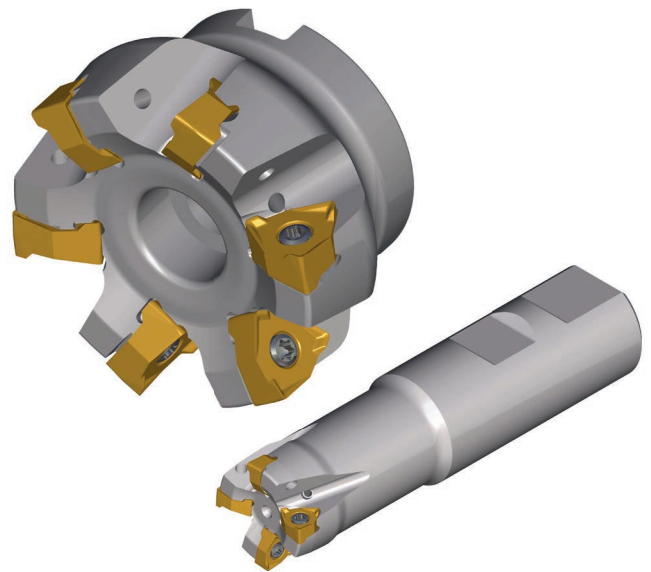

3D Milling

ISO 00P

Ø 40 mm - 160 mm Face Milling Cutter
Insert size 10, 12 and 16

Ø 1 1/2" - 5"
Insert Size 10, 12, 16

Ø 15 mm - 20 mm End Milling Cutter
Insert size 07 and 10

Ø 10 mm - 42 mm Screw on type
Insert size 05, 07, 10, 12 and 16

Page 86

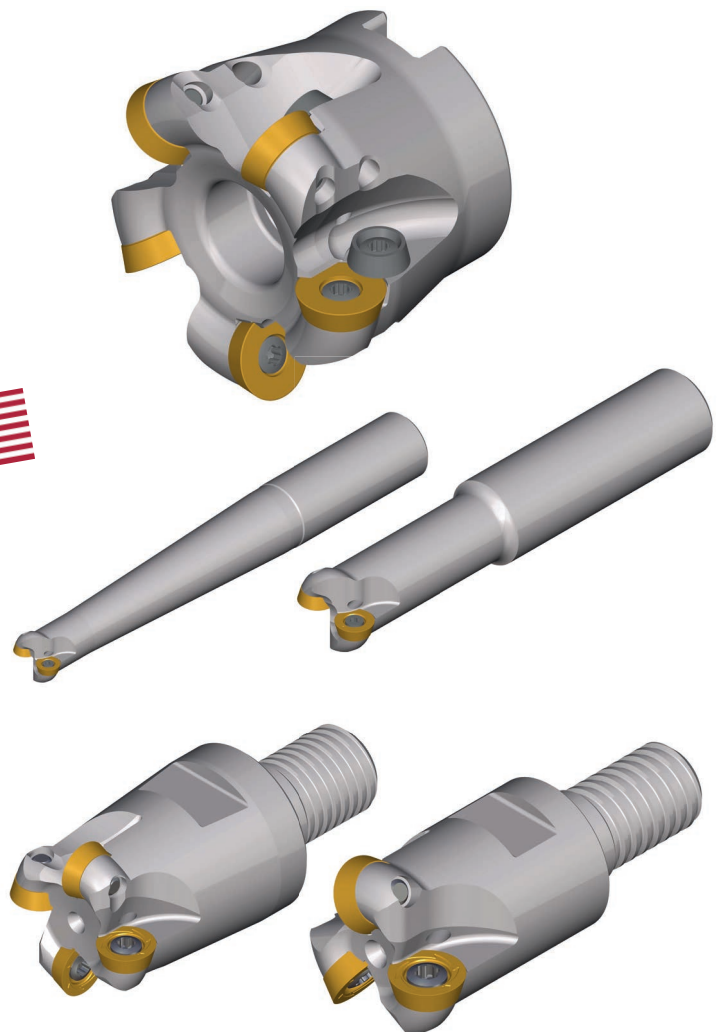

3D Milling

RHOMBICtec 95P

Ø 16 mm - 25 mm Face Milling Cutter
Insert size 06

Page 93



BALLtec

Ø 8 mm - 25 mm End Milling Cutter Steel Shank
Insert size 08 to 25

Ø 8 mm - 32 mm End Milling Cutter Solid Carbide Shank
Insert size 08 to 32

Ø 8 mm - 32 mm Screw on type Steel Shank
Insert size 08 to 32

Page 95



Cutter designation system

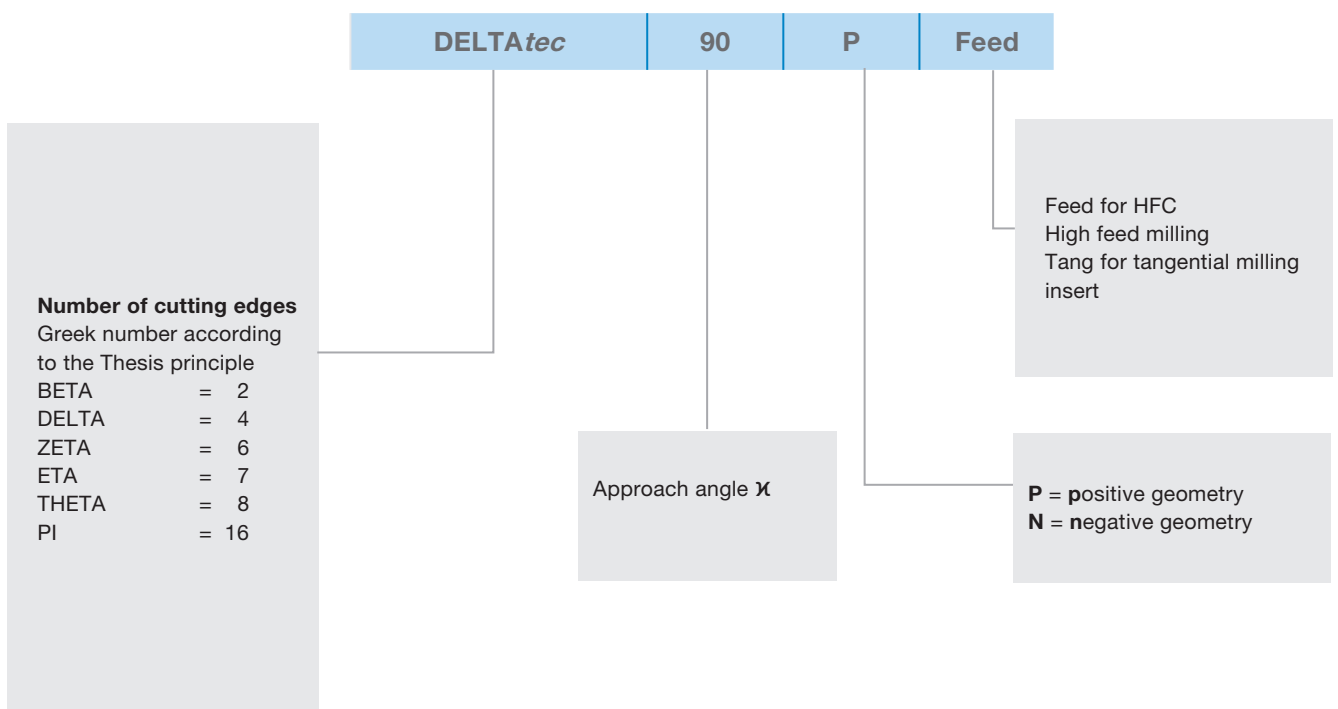
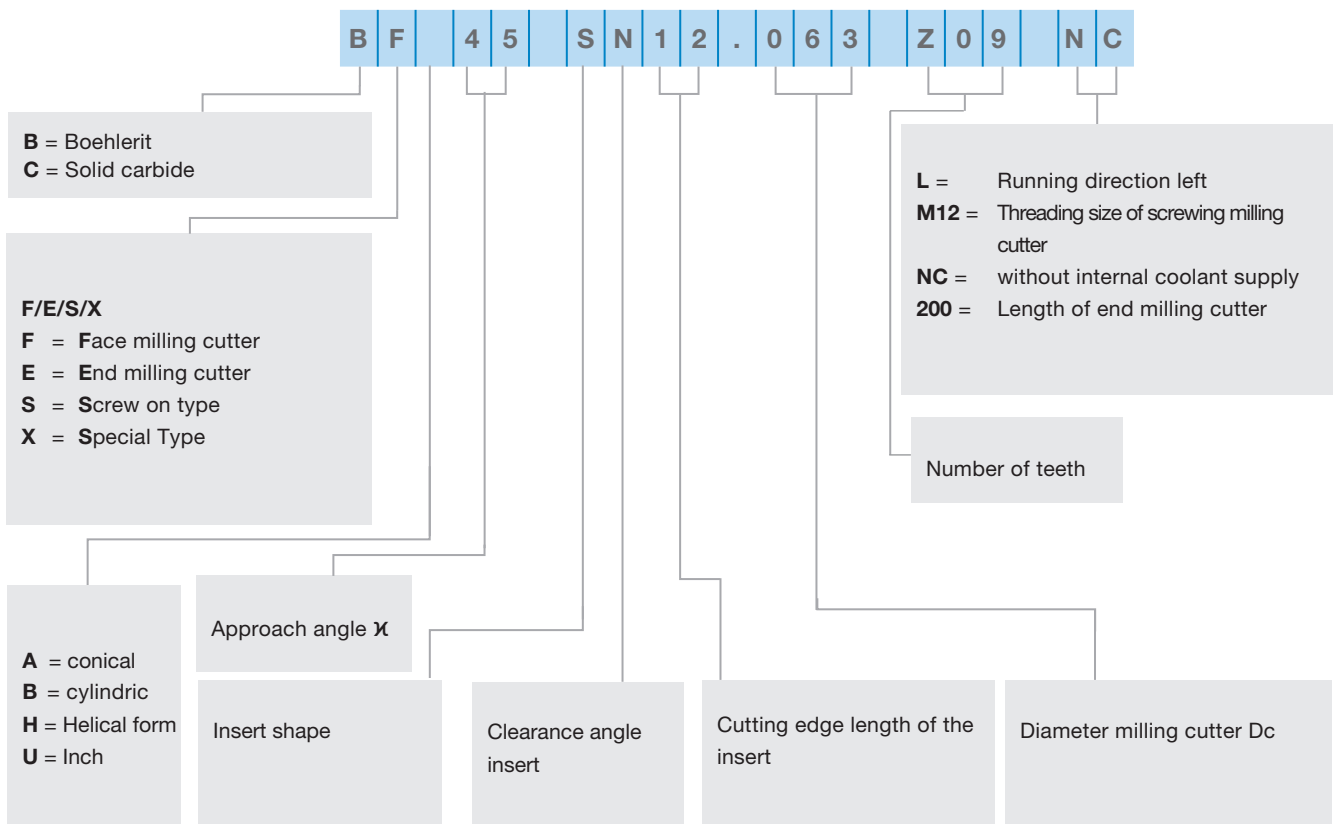

Cutting materials, designation system

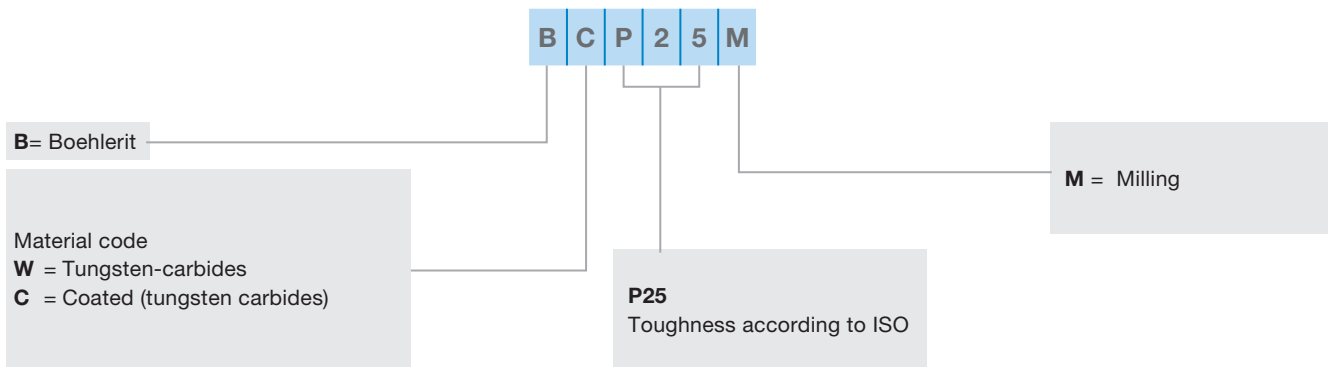



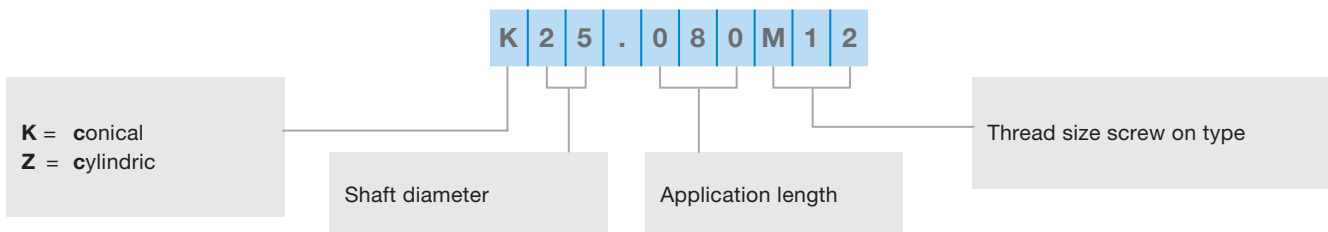



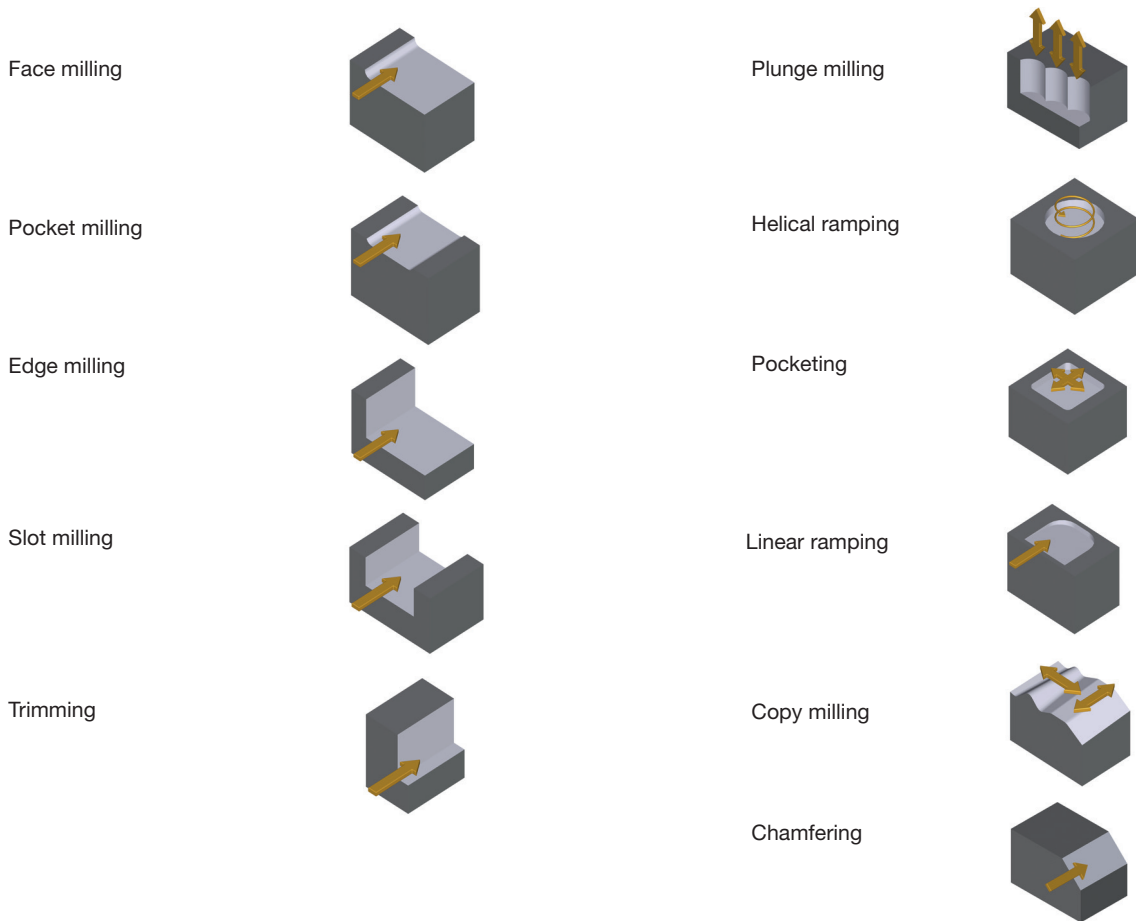

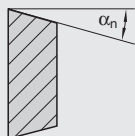
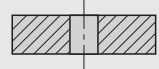

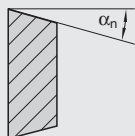



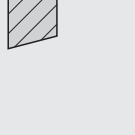
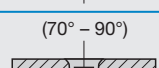

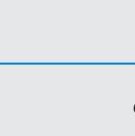
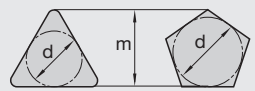
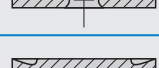

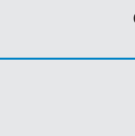
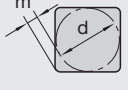
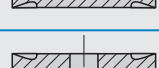

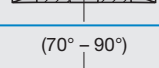





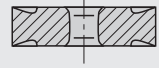





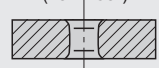

Solid carbide extension, designation system

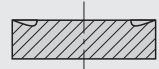

Symbols for milling operations

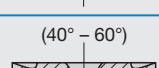

S	N	M	X	12																																																																														
Insert shape	Clearance angle	Tolerances	Chip breaker. fixation	Cutting edge length																																																																														
A  85°		<table border="1"> <thead> <tr> <th></th> <th>m</th> <th>s</th> <th>d</th> </tr> </thead> <tbody> <tr><td>A</td><td>±0.005</td><td>±0.025</td><td>±0.025</td></tr> <tr><td>C</td><td>±0.013</td><td>±0.025</td><td>±0.025</td></tr> <tr><td>E</td><td>±0.025</td><td>±0.025</td><td>±0.025</td></tr> <tr><td>F</td><td>±0.005</td><td>±0.025</td><td>±0.013</td></tr> <tr><td>G</td><td>±0.025</td><td>±0.13</td><td>±0.025</td></tr> <tr><td>H</td><td>±0.013</td><td>±0.025</td><td>±0.013</td></tr> <tr><td>J</td><td>±0.005</td><td>±0.025</td><td>see Tab. 4</td></tr> <tr><td>K</td><td>±0.013</td><td>±0.025</td><td>see Tab. 4</td></tr> <tr><td>L</td><td>±0.025</td><td>±0.025</td><td>see Tab. 4</td></tr> <tr><td>M</td><td>see Tab. 5</td><td>±0.13</td><td>see Tab. 4</td></tr> <tr><td>N</td><td>see Tab. 5</td><td>±0.025</td><td>see Tab. 4</td></tr> <tr><td>U</td><td>see Tab. 5</td><td>±0.13</td><td>see Tab. 4</td></tr> </tbody> </table>		m	s	d	A	±0.005	±0.025	±0.025	C	±0.013	±0.025	±0.025	E	±0.025	±0.025	±0.025	F	±0.005	±0.025	±0.013	G	±0.025	±0.13	±0.025	H	±0.013	±0.025	±0.013	J	±0.005	±0.025	see Tab. 4	K	±0.013	±0.025	see Tab. 4	L	±0.025	±0.025	see Tab. 4	M	see Tab. 5	±0.13	see Tab. 4	N	see Tab. 5	±0.025	see Tab. 4	U	see Tab. 5	±0.13	see Tab. 4	A 	<table border="1"> <thead> <tr> <th></th> <th>l</th> </tr> </thead> <tbody> <tr><td>06</td><td>6.350</td></tr> <tr><td>07</td><td>7.938</td></tr> <tr><td>09</td><td>9.525</td></tr> <tr><td>11</td><td>11.000</td></tr> <tr><td>12</td><td>12.700</td></tr> <tr><td>15</td><td>15.875</td></tr> <tr><td>16</td><td>16.500</td></tr> <tr><td>19</td><td>19.050</td></tr> <tr><td>22</td><td>22.000</td></tr> <tr><td>25</td><td>25.400</td></tr> <tr><td>31</td><td>31.750</td></tr> <tr><td>38</td><td>38.100</td></tr> </tbody> </table>		l	06	6.350	07	7.938	09	9.525	11	11.000	12	12.700	15	15.875	16	16.500	19	19.050	22	22.000	25	25.400	31	31.750	38	38.100
		m	s	d																																																																														
A		±0.005	±0.025	±0.025																																																																														
C		±0.013	±0.025	±0.025																																																																														
E		±0.025	±0.025	±0.025																																																																														
F		±0.005	±0.025	±0.013																																																																														
G		±0.025	±0.13	±0.025																																																																														
H		±0.013	±0.025	±0.013																																																																														
J		±0.005	±0.025	see Tab. 4																																																																														
K		±0.013	±0.025	see Tab. 4																																																																														
L	±0.025	±0.025	see Tab. 4																																																																															
M	see Tab. 5	±0.13	see Tab. 4																																																																															
N	see Tab. 5	±0.025	see Tab. 4																																																																															
U	see Tab. 5	±0.13	see Tab. 4																																																																															
	l																																																																																	
06	6.350																																																																																	
07	7.938																																																																																	
09	9.525																																																																																	
11	11.000																																																																																	
12	12.700																																																																																	
15	15.875																																																																																	
16	16.500																																																																																	
19	19.050																																																																																	
22	22.000																																																																																	
25	25.400																																																																																	
31	31.750																																																																																	
38	38.100																																																																																	
B  82°		<table border="1"> <thead> <tr> <th colspan="2">d</th> <th>J, K, L, M</th> <th>U</th> </tr> <tr> <th>over</th> <th>up to</th> <th></th> <th></th> </tr> </thead> <tbody> <tr><td>3.9</td><td>10.0</td><td>±0.05</td><td>±0.08</td></tr> <tr><td>10.0</td><td>15.0</td><td>±0.08</td><td>±0.13</td></tr> <tr><td>15.0</td><td>20.0</td><td>±0.10</td><td>±0.18</td></tr> <tr><td>20.0</td><td>26.0</td><td>±0.13</td><td>±0.25</td></tr> <tr><td>26.0</td><td>32.0</td><td>±0.15</td><td>±0.25</td></tr> </tbody> </table>	d		J, K, L, M	U	over	up to			3.9	10.0	±0.05	±0.08	10.0	15.0	±0.08	±0.13	15.0	20.0	±0.10	±0.18	20.0	26.0	±0.13	±0.25	26.0	32.0	±0.15	±0.25	B (70° - 90°) 																																																			
d		J, K, L, M	U																																																																															
over		up to																																																																																
3.9		10.0	±0.05	±0.08																																																																														
10.0		15.0	±0.08	±0.13																																																																														
15.0		20.0	±0.10	±0.18																																																																														
20.0		26.0	±0.13	±0.25																																																																														
26.0		32.0	±0.15	±0.25																																																																														
C  80°			<table border="1"> <thead> <tr> <th colspan="2">d</th> <th>M, N</th> <th>U</th> </tr> <tr> <th>over</th> <th>up to</th> <th></th> <th></th> </tr> </thead> <tbody> <tr><td>3.9</td><td>10.0</td><td>±0.08</td><td>±0.13</td></tr> <tr><td>10.0</td><td>15.0</td><td>±0.13</td><td>±0.20</td></tr> <tr><td>15.0</td><td>20.0</td><td>±0.15</td><td>±0.27</td></tr> <tr><td>20.0</td><td>26.0</td><td>±0.18</td><td>±0.38</td></tr> <tr><td>26.0</td><td>32.0</td><td>±0.20</td><td>±0.38</td></tr> </tbody> </table>	d		M, N	U	over	up to			3.9	10.0	±0.08	±0.13	10.0	15.0	±0.13	±0.20	15.0	20.0	±0.15	±0.27	20.0	26.0	±0.18	±0.38	26.0	32.0	±0.20	±0.38	C (70° - 90°) 																																																		
d			M, N	U																																																																														
over	up to																																																																																	
3.9	10.0		±0.08	±0.13																																																																														
10.0	15.0		±0.13	±0.20																																																																														
15.0	20.0		±0.15	±0.27																																																																														
20.0	26.0		±0.18	±0.38																																																																														
26.0	32.0		±0.20	±0.38																																																																														
D  55°			 <p>Corner rounding uneven number of sides</p>	F 																																																																														
E  75°				 <p>Corner rounding even number of sides</p>	G 																																																																													
H  120°		A		3°	H (70° - 90°) 																																																																													
K  55°		B		5°	J (70° - 90°) 																																																																													
L  90°		C		7°	M 																																																																													
M  86°		D		15°	N 																																																																													
O  135°		E		20°	Q (40° - 60°) 																																																																													
P  108°		F		25°	R 																																																																													
R  -		G		30°	T (40° - 60°) 																																																																													
S  90°		N		0°	U (40° - 60°) 																																																																													
T  60°	P	11°		W (40° - 60°) 																																																																														
V  35°	O																																																																																	
W  80°																																																																																		

The corner angle is in the case of not equiangular basic forms always the smaller angle.

Normal clearance angles, which require a special description.

Chamfered inserts

X with special feature according to drawing

() Cone angle for screw

06 Thickness	
	S
02	2.38
03	3.18
T3	3.97
04	4.76
05	5.56
06	6.35
07	7.94
08	8.00
09	9.52
Dimensions in mm	

AN Cutting edge corner	
For radius inserts	
	Corner radius-r
00	sharp-edged
02	0.2
04	0.4
08	0.8
12	1.2
16	1.6
20	2.0
	usw. etc.
For chamfered inserts face milling	
	Approach angle
	χ_r
A	45°
D	60°
E	75°
F	85°
P	90°
Z	Special
	Clearance angle of face milling edge α_n
A	3°
B	5°
C	7°
D	15°
E	20°
F	25°
G	30°
N	0°
P	11°
Z	Special
MO	Round insert metric
OO	Round insert Inch

S Cutting edge type ¹⁾	
sharp-edged	
rounded	
chamfered	
chamfered and rounded*	
double chamfered	
double chamfered and rounded	

N Direction of cut ¹⁾	
right hand cut only	
left hand cut only	
right and left hand cut	
1)The use of these reference letters is optional	

- MP Boehrer-Standard	
Geometry code	
Example:	
S N M X 12 06 AN S N-MP	
#	1 2 3 4 5 6 7 8 9 10
1	Basic form square
2	Clearance angle 0°
3	Tolerances m ± 0.013 s ± 0.025 d ± 0.13
4	Fixing cutting face with special feature according to drawing
5	Length of cutting edge 12.7
6	Thickness 6.35
7	Cutting edge corner 45° chamfer/clearance angle
8	Cutting edge *
9	Direction of cut right- and lefthand
10	Internal designation MP = Geometry

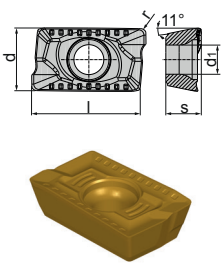
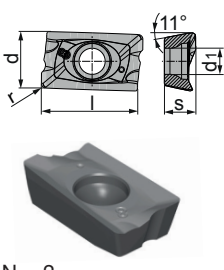
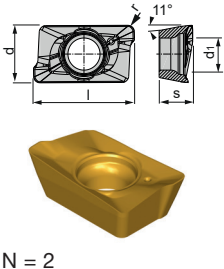
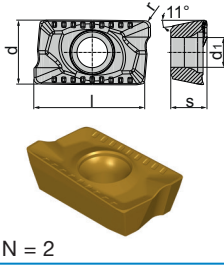
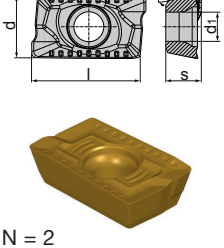
N = Number of cutting edges	Ordering code	l	d	s	d ₁	r	Cutting materials										Assignment tools		
							BCP20M	BCP25M	BCP30M	BCP35M	BCP40M	BCM35M	BCM40M	BCK15M	BCK20M	BCN10M		BWN10M	
 N = 2	ADKX 110308 SRTR	11.9	7.9	3.47	3.4	0.8				●									
 N = 2	APHT 100304 FR-MN	10	6.7	3.5	2.8	0.4											●	●	
	APHT 160408 FR-MN	16	9.52	5.26	4.5	0.8											●	●	
	APHT 100304 FR-MN2	10	6.7	3.5	2.8	0.4											●	●	
	APHT 160408 FR-MN2	16	9.52	5.26	4.5	0.8											●	●	
 N = 2	APKT 060204-PDTR	6	3.65	2.15	2.05	0.4		●		●		●							
 N = 2	APKT 1003 PDSR-BP	10	6.7	3.5	2.8	0.5		●	●	●				●	●				
	APKT 1003 PDSR-BM	10	6.7	3.5	2.8	0.5						●							
	APKT 1604 PDSR-BP	16	9.52	5.26	4.5	0.8		●	●	●				●					
	APKT 1604 PDSR-BM	16	9.52	5.26	4.5	0.8						●							
	APKT 160416 SR-BP	16	9.52	5.26	4.5	1.6				●									
	APKT 160424 SR-BP	16	9.52	5.26	4.5	2.4				●									
	APKT 160432 SR-BP	16	9.52	5.26	4.5	3.2				●									
 N = 2	APKT 15T3 PDTR-BP	15	9.73	4.36	4.5	0.8			●	●									

Page 66

Order example: 10 pieces ADKX 110308 SRTR BCP35M

Colours and execution of the original indexable inserts, may deviate from the illustration!

- Available from stock
- On request

N = Number of cutting edges	Ordering code	l	d	s	d ₁	r	Cutting materials										Assignment tools				
							BCP20M	BCP25M	BCP30M	BCP35M	BCP40M	BCM35M	BCM40M	BCK15M	BCK20M	BCN10M		BWN10M			
<p>N=2</p>	APKT 100304 SR-MP2	10	6.7	3.5	2.8	0.4	●														
	APKT 100304 SR-MM2	10	6.7	3.5	2.8	0.4						●									
	APKT 100304 SR-RP2	10	6.7	3.5	2.8	0.4			●	●	●										
	APKT 100304 SR-RK2	10	6.7	3.5	2.8	0.4								●	●						
	APKT 160408 SR-MP2	16	9.52	5.26	4.5	0.8	●														
	APKT 160408 SR-MM2	16	9.52	5.26	4.5	0.8							●								
	APKT 160408 SR-RP2	16	9.52	5.26	4.5	0.8			●	●	●										
	APKT 160408 SR-RK2	16	9.52	5.26	4.5	0.8									●	●					

Page 66

N = Number of cutting edges	Ordering code	l	d	s	d ₁	r	Cutting materials				Assignment tools
							BCH03M	BCH10M	BCH23M	BCH30M	
<p>N = 2</p>	BE12-FHF		12	2.99	3.5		●				
	BE12-SHF		12	2.99	3.5			●			
	BE12-MHF		12	2.99	3.5						●
	BE16-FHF		16	3.99	4		●				
	BE16-SHF		16	3.99	4			●		●	
	BE16-MHF		16	3.99	4						●
	BE20-FHF		20	4.99	5		●				
	BE20-SHF		20	4.99	5			●		●	
	BE20-MHF		20	4.99	5						●
	BE25-SHF		25	5.99	6				●	●	
	BE25-MHF		25	5.99	6						●
	BE32-SHF		32	6.99	8				●	●	
	BE32-MHF		32	6.99	8						●

Page 95

Order example: 10 pieces APKT 100304 SR-MP2 BCP25M

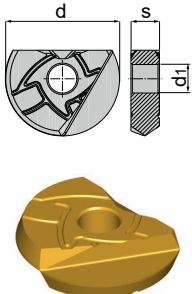
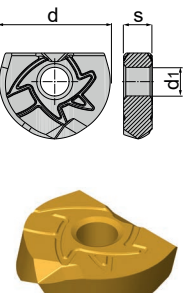
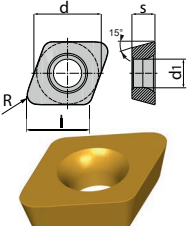
N = Number of cutting edges	Ordering code	l	d	s	d ₁	r	Cutting materials				Assignment tools
							BCH03M	BCH10M	BCH23M	BCH30M	
	BE08-MHN		8	2.39	2.5			●	●	●	Page 95
	BE10-MHN		10	2.59	3			●	●	●	
	BE12-SHN		12	2.99	3.5		●				
	BE12-MHN		12	2.99	3.5			●	●	●	
	BE16-SHN		16	3.99	4		●				
	BE16-MHN		16	3.99	4			●	●	●	
	BE20-SHN		20	4.99	5		●				
	BE20-MHN		20	4.99	5			●	●	●	
	BE25-MHN		25	5.99	6			●	●	●	
	BE32-MHN		32	6.99	8			●	●	●	
N = 2											
	BE08-MHN2		8	2.39	2.5				●	●	Page 95
	BE08-SHN2		8	2.39	2.5					●	
	BE10-MHN2		10	2.59	3				●	●	
	BE10-SHN2		10	2.59	3					●	
	BE12-FHN2		12	2.99	3.5		●				
	BE12-MHN2		12	2.99	3.5			●		●	
	BE12-SHN2		12	2.99	3.5				●		
	BE16-FHN2		16	3.99	4		●				
	BE16-MHN2		16	3.99	4			●		●	
	BE16-SHN2		16	3.99	4				●		
BE20-FHN2		20	4.99	5		●					
BE20-MHN2		20	4.99	5			●		●		
BE20-SHN2		20	4.99	5				●			
BE25-MHN2		25	5.99	6			●		●		
BE25-SHN2		25	5.99	6				●			
N = 2											
	CDGX 060210 SR-FH	5.8	6.5	2.38	2.9	1	●	●	●	●	Page 93
	CDGX 060210 SR-FW	1.72	6.5	2.38	2.9	1	●	●			

Order example: 10 pieces BE08-MHN BCH10M

- Available from stock
- On request
- Available 4th quarter 2018

Colours and execution of the original indexable inserts, may deviate from the illustration!

N = Number of cutting edges	Ordering code	l	d	s	d ₁	r	Cutting materials											Assignment tools							
							BCP20M	BCP25M	BCP30M	BCP35M	BCP40M	BCM35M	BCM40M	BCK15M	BCK20M	BCK35M	BCN10M		BCN15M	BWN10M					
	LDMX 100408 SR-MP	10	6.6	4.76	2.8	0.8	●	●	●															Page 44	
	LDMX 100408 SR-MM	10	6.6	4.76	2.8	0.8						●	●												
	LDMX 100408 SR-MK	10	6.6	4.76	2.8	0.8									●										
	LDMX 100408 SR-MT	10	6.6	4.76	2.8	0.8										□									
	LDMX 100408 FR-MN	10	6.6	4.76	2.8	0.8																	●		
	LDMX 100420 SR-MP	10	6.6	4.76	2.8	2.0		●		●															
	LDMX 100430 SR-MP	10	6.6	4.76	2.8	3.0		●		●															
	LDMX 180508 FR-MN	18	9.65	5	4.15	0.8																	●		●
	LDMX 180508 SR-MP	18	9.65	5	4.15	0.8		●		●	●														
	LDMX 180508 SR-MM	18	9.65	5	4.15	0.8							●	●											
	LDMX 180508 SR-MK	18	9.65	5	4.15	0.8									●										
	LDMX 180512 SR-RP	18	9.65	5	4.15	1.2		●		●	●														
	LDMX 180512 SR-RK	18	9.65	5	4.15	1.2									●										
		LDMX 100415 SR-MPH	1.5	6.6	4.76	2.8	1.5	●	●	●	●														
LDMX 100415 SR-MMH		1.5	6.6	4.76	2.8	1.5						●	●												
LDMX 100415 SR-MKH		1.5	6.6	4.76	2.8	1.5									●	●									
	LNMX 100605 SR-RP	10	6.6	6.35	2.8	0.5		●		●	●													Page 60	
	LNMX 100605 SR-RK	10	6.6	6.35	2.8	0.5								●	●										
	LNMX 100605 SR-RM	10	6.6	6.35	2.8	0.5										●									
	LNMX 151008 SR-RP	15	9.52	10.0	4.5	0.8		●		●	●														
	LNMX 151008 SR-RK	15	9.52	10.0	4.5	0.8									●	●									
	LNMX 151008 SR-RM	15	9.52	10.0	4.5	0.8										●									
	LNMX 131308 SR-MP	13	7	13	4.6	0.8		●		●														Page 64	
	LNMX 131308 SR-MM	13	7	13	4.6	0.8									●										
	LNMX 131308 SR-RP	13	7	13	4.6	0.8				●	●	●													
	LNMX 131308 SR-RK	13	7	13	4.6	0.8									●	●									

Order example: 10 pieces LDMX 100408 SR-MP BCP25M

- Available from stock
- On request
- Available 4th quarter 2018

								Cutting materials										Assignment tools			
N = Number of cutting edges	Ordering code	l	d	s	d ₁	r	BCP20M	BCP25M	BCP30M	BCP35M	BCP40M	BCM35M	BCM40M	BCK15M	BCK20M	BCH03M	BCH05M		BCH10M	BCH23M	BCH30M
<p>N = 8</p>	OFER 070405 SN-BP	7	18.1	4.76	-	0.5	●														
	OFEX 05T305 SN-BP	5	12.7	3.97	4.6	0.5	●	●	●												
<p>N = 16</p>	ONMU 050608 SN-MP	5.24	12.7	5.8	5.45	0.8	●		●												
	ONMU 050608 SN-MM	5.24	12.7	5.8	5.45	0.8						●	●								
	ONMU 050608 SN-MH	5.24	12.7	5.8	5.45	0.8															●
	ONMU 050608 SN-MK	5.24	12.7	5.8	5.45	0.8										●					
	ONMU 080608 SN-MP	8	19	6.95	6.75	0.8	●	●	●	●											
	ONMU 080608 SN-MM	8	19	6.95	6.75	0.8						●	●								
	ONMU 080608 SN-MK	8	19	6.95	6.75	0.8									●	●					
	ONMQ 0806-FW	8	19.1	6.95	6.75	-							●								○
	RDHT 12T3MO-MM	-	12	3.97	4.4	-						●	●								
	RDHW 0501 MOS-FH	-	5	1.5	2.2	-										●					
	RDHW 0702 MOS-FH	-	7	2.38	2.7	-										●					
	RDHW 1003 MOS-FH	-	10	3.18	3.9	-											●				

Order example: 10 pieces OFER 070405 SN-BP BCP25M

Colours and execution of the original indexable inserts, may deviate from the illustration!

- Available from stock
- On request

N = Number of cutting edges	Ordering code	l	d	s	d ₁	Cutting materials												Assignment tools	
						BCP20M	BCP25M	BCP30M	BCP35M	BCP40M	BCM35M	BCM40M	BCK15M	BCK20M	BCH03M	BCH05M	BCH10M		BCH23M
	RDKT 12T3 MOS-MP		12	3.97	3.9	●	●	●	●										
	RDKT 12T3 MOS-MM		12	3.97	3.9						●	●							
	RDKT 1604 MOS-MP		16	4.76	5.2	●	●	●	●										
	RDKT 1604 MOS-MM		16	4.76	5.2						●	●							
	RDKW 0501 MOS-MH		5	1.5	2.2											●	●		
	RDKW 0501 MOS-MP		5	1.5	2.2	●	●												
	RDKW 0501 MOS-MM		5	1.5	2.2						●	●							
	RDKW 0501 MOS-MK		5	1.5	2.2								●	●					
	RDKW 0501 MOS-RH		5	1.5	2.2														●
	RDKW 0702 MOS-MH		7	2.38	2.7												●	●	
	RDKW 0702 MOS-MP		7	2.38	2.7	●	●	●	●										
	RDKW 0702 MOS-MM		7	2.38	2.7						●	●							
	RDKW 0702 MOS-MK		7	2.38	2.7								●	●					
	RDKW 0702 MOS-RH		7	2.38	2.7														●
	RDKW 1003 MOS-MH		10	3.18	3.9												●	●	
	RDKW 1003 MOS-MP		10	3.18	3.9	●	●	●	●										
	RDKW 1003 MOS-MM		10	3.18	3.9						●	●							
	RDKW 1003 MOS-MK		10	3.18	3.9								●	●					
	RDKW 1003 MOS-RH		10	3.18	3.9														●
	RDKW 12T3 MOS-MH		12	3.97	3.9												●	●	
	RDKW 12T3 MOS-MP		12	3.97	3.9	●	●	●	●										
	RDKW 12T3 MOS-MK		12	3.97	3.9								●	●					
	RDKW 12T3 MOS-RH		12	3.97	3.9														●
	RDKW 1604 MOS-MH		16	4.76	5.2												●	●	
RDKW 1604 MOS-MP		16	4.76	5.2	●	●	●	●											
RDKW 1604 MOS-MK		16	4.76	5.2								●	●						
RDKW 1604 MOS-RH		16	4.76	5.2														●	
	REMW 1304MO-MP	-	13.2	4.76	4.6	●	●	●	●										
	REMW 1304MO-MM	-	13.2	4.76	4.6							●							
	REMW 1304MO-MK	-	13.2	4.76	4.6								●	●					
	REMW 1304MO-MH	-	13.2	4.76	4.6											●	●		●

Order example: 10 pieces RDKT 12T3 MOS-MP BCP20M

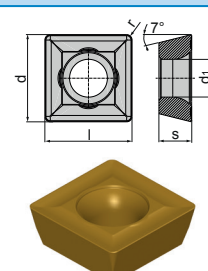
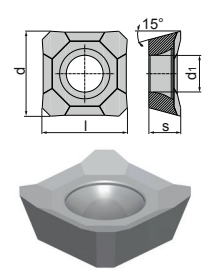
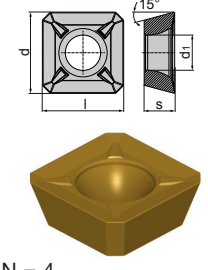
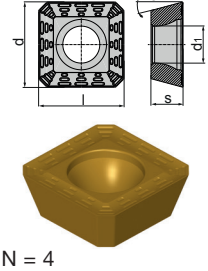
N = Number of cutting edges	Ordering code	l	d	s	d ₁	r	Cutting materials										Assignment tools						
							BCP20M	BCP25M	BCP30M	BCP35M	BCP40M	BCM35M	BCM40M	BCK15M	BCK20M	BCK35M		BCN10M	BWN10M				
 <p>N = 4</p>	SCMX 120512	12.70	12.70	5.56	5.5	1.2			●														
 <p>N = 4</p>	SDHT 1204 AEFN-ALC	12.70	12.70	4.76	5.5	-																	
	SDHT 1504 AEFN-ALC	15.88	15.88	4.76	5.5	-																●	●
 <p>N = 4</p>	SDHT 1204 AESN	12.70	12.70	4.76	5.5	-		●	●	●				●									
	SDHT 1504 AESN	15.88	15.88	4.76	5.5	-			●														
 <p>N = 4</p>	SDHT 1204 AESN-BM	12.70	12.70	4.76	5.5	-								●									
N = 4																							

Order example: 10 pieces SCMX 120512 BCP30M

Colours and execution of the original indexable inserts, may deviate from the illustration!

- Available from stock
- On request

N = Number of cutting edges	Ordering code	l	d	s	d ₁	r	Cutting materials											Assignment tools									
							BCP20M	BCP25M	BCP30M	BCP35M	BCP40M	BCM35M	BCM40M	BCK15M	BCK20M	BCS35M	BCN15M		BCH05M	BCH10M	BCH30M						
<p>N = 4</p>	SDMT 090308	9.52	9.52	3.18	4	0.8	●																				
	SDMT 120408-SN	12.70	12.70	4.76	5.5	0.8		●																			
	SDMT 1205 PDSR-BP	12.70	12.70	5.56	5.5	-			●	●																	
<p>N = 4</p>	SDMT 100408 SR-MP	10.4	10.4	4.86	3.5	0.8	●		●	●																	
	SDMT 100408 ER-MM	10.4	10.4	4.86	3.5	0.8					●	●															
	SDMT 100408 SR-MK	10.4	10.4	4.86	3.5	0.8							●														
	SDMT 100408 FR-MN	10.4	10.4	4.86	3.5	0.8									●												
	SDMT 140512 SR-MP	14.8	14.8	5.2	5.5	1.2	●		●	●																	
	SDMT 140512 ER-MM	14.8	14.8	5.2	5.5	1.2					●	●															
	SDMT 140512 SR-MK	14.8	14.8	5.2	5.5	1.2							●														
	SDMT 140512 FR-MN	14.8	14.8	5.2	5.5	1.2									●												
<p>N = 4</p>	SDMT 100415 SR-MPH	1.1	10.2	4.76	3.5	1.5	●	●	●	●																	
	SDMT 100415 ER-MMH	1.1	10.2	4.76	3.5	1.5					●	●															
	SDMT 100415 SR-MHH	1.1	10.2	4.76	3.5	1.5																		●			
	SDGT 100415 SR-MTH	1.1	10.2	4.76	3.5	1.5																					
	SDMT 140520 SR-MPH	2.2	14.7	5	5.5	2	●	●	●	●																	
	SDMT 140520 ER-MMH	2.2	14.7	5	5.5	2					●	●															
	SDMT 140520 SR-MHH	2.2	14.7	5	5.5	2																			●		
	SDMT 180630 SR-MPH	3	18.7	6	6.5	3.0	●		●																		
	SDMT 180630 SR-MMH	3	18.7	6	6.5	3.0					●	●															
<p>N = 4</p>	SDMW 100415 SR-RPH	1.1	10.2	4.76	3.5	1.5	●	●	●	●																	
	SDMW 100415 SR-RKH	1.1	10.2	4.76	3.5	1.5							●	●													
	SDMW 100415 SR-RHH	1.1	10.2	4.76	3.5	1.5																	●	●	●		
	SDMW 140520 SR-RPH	2.2	14.7	5	5.5	2	●	●	●	●																	
	SDMW 140520 SR-RKH	2.2	14.7	5	5.5	2							●	●													
	SDMW 140520 SR-RHH	2.2	14.7	5	5.5	2																		●	●	●	
	SDMW 180630 SR-RPH	3	18.7	6	6.5	3.0			●	●																	
	SDMW 180630 SR-RKH	3	18.7	6	6.5	3.0							●	●													
	SDMW 180630 SR-RHH	3	18.7	6	6.5	3.0																			●		

Order example: 10 pieces SDMT 090308 BCP25M

● Available from stock
○ On request

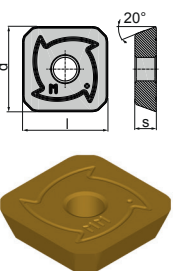
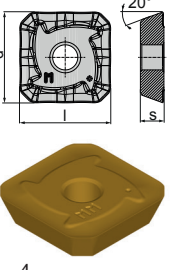
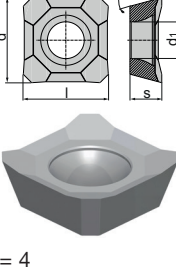
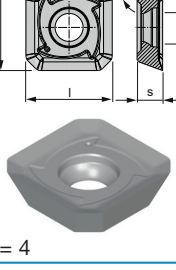
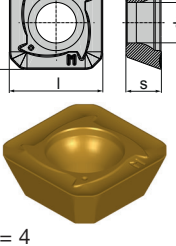
N = Number of cutting edges	Ordering code	l	d	s	d ₁	r	Cutting materials										Assignment tools	
							BCP20M	BCP25M	BCP30M	BCP35M	BCP40M	BCM35M	BCM40M	BCK15M	BCK20M	BCN10M		BWN10M
 <p>N = 4</p>	SEKN 1203 AFSN-MP	12.70	12.70	3.18	-	-		●	●	●								
	SEKN 1203 AFEN-MM	12.70	12.70	3.18	-	-						●						
	SEKN 1203 AFSN-MK	12.70	12.70	3.18	-	-							●	●				
	SEKN 1504 AFSN-MP	15.88	15.88	4.76	-	-	●	●	●	●	●							
	SEKN 1504 AFEN-MM	15.88	15.88	4.76	-	-					●	●						
	SEKN 1504 AFSN-MK	15.88	15.88	4.76	-	-							●					
 <p>N = 4</p>	SEKR 1203 AFSN-MP	12.70	12.70	3.18	-	-		●	●	●								
	SEKR 1203 AFEN-MM	12.70	12.70	3.18	-	-						●						
 <p>N = 4</p>	SEHT 1204 AFFN-ALC	12.70	12.70	4.76	5.5	-										●	●	
 <p>N = 4</p>	SEHT 13T3 AZFN-MN	13.4	13.4	3.97	4.2											●	●	
 <p>N = 4</p>	SEKT 1204 AFSN-MP	12.70	12.70	4.76	5.5	-	●	●	●	●								
	SEKT 1204 AFEN-MM	12.70	12.70	4.76	5.5	-					●	●						
	SEKT 13T3 AFSN-MP	13.4	13.4	3.97	4.2	-	●	●	●	●								
	SEKT 13T3 AFEN-MM	13.4	13.4	3.97	4.2	-					●	●						

Order example: 10 pieces SEKN 1203 AFSN-MP BCP25M

N = Number of cutting edges	Ordering code	l	d	s	d ₁	r	Cutting materials										Assignment tools	
							BCP20M	BCP25M	BCP30M	BCP35M	BCP40M	BCM35M	BCM40M	BCK15M	BCK20M	BCN10M		BWN10M
 	SEKW 1204 AFSN-MP	12.70	12.70	4.76	5.5	-	●	●	●	●								Page 38
	SEKW 1204 AFEN-MM	12.70	12.70	4.76	5.5	-					●							
	SEKW 1204 AFSN-MK	12.70	12.70	4.76	5.5	-						●	●					
	SEKW 13T3 AFSN-MP	13.4	13.4	3.97	4.2	-	●	●	●	●								Page 36
	SEKW 13T3 AFEN-MM	13.4	13.4	3.97	4.2	-					●							
	SEKW 13T3 AFSN-MK	13.4	13.4	3.97	4.2	-						●	●					
 	SNMX 1206 ANSN-MP	12.70	12.70	6.35	5.2	-	●	●	●	●							Page 76	
	SNMX 1206 ANSN-MM	12.70	12.70	6.35	5.2	-					●	●						
	SNMX 1206 ANSN-MK	12.70	12.70	6.35	5.2	-						●	●					
	SNEX 1206-FW	12.70	12.70	6.35	5.2	-					●							
	SNMX 120608 SN-MP	12.70	12.70	6.35	5.2	0.8			●	●								
SNMX 120608 SN-MM	12.70	12.70	6.35	5.2	0.8						●							
SNMX 120608 SN-MK	12.70	12.70	6.35	5.2	0.8							●	●					
SNMX 120612 SN-MP	12.70	12.70	6.35	5.2	1.2			●	●									
SNMX 120612 SN-MK	12.70	12.70	6.35	5.2	1.2							●	●					
 	SPKN 1203 EDSR-MP	12.70	12.70	3.18	-	-	●	●	●	●								
	SPKN 1203 EDSR-MK	12.70	12.70	3.18	-	-						●	●					
	SPKN 1504 EDSR-MP	15.88	15.88	4.76	-	-	●	●	●	●								
	SPKN 1504 EDSR-MK	15.88	15.88	4.76	-	-						●	●					
	SPKN 2506 DZSR-MP	25.4	25.4	6.35	-	-			●	●								
 	SPKR 1203 EDSR	12.70	12.70	3.18	-	-		●										

Order example: 10 pieces SEKW 1204 AFSN-MP BCP25M

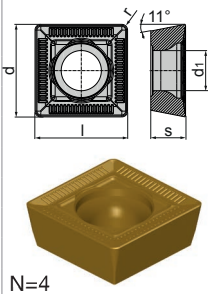
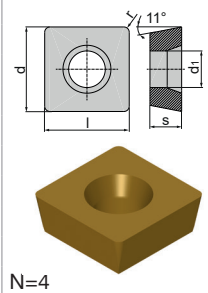
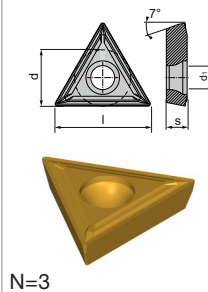
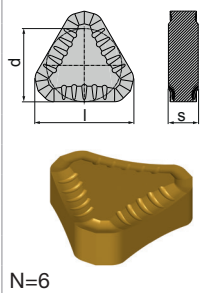
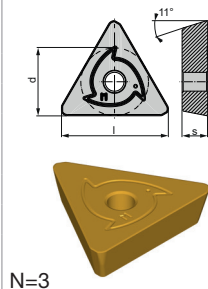
N = Number of cutting edges	Ordering code	l	d	s	d ₁	r	Cutting materials										Assignment tools			
							BCP20M	BCP25M	BCP30M	BCP35M	BCP40M	BCM35M	BCM40M	BCK15M	BCK20M	BCN10M		BWN10M		
 <p>N=4</p>	SPMT 060304	6.35	6.35	3.18	3.4	0.4				●										
	SPMT 120408-SN	12.70	12.70	4.76	5.2	0.8				●	●									
 <p>N=4</p>	SPMW 120408	12.70	12.70	4.76	5.2	0.8														
 <p>N=3</p>	TCMT 110202 EN	10.4	6.35	2.38	2.8	0.2				●										
	TCMT 16T304 EN	15.5	9.52	3.97	4.4	0.4				●										
 <p>N=6</p>	TNHF 1204 ANSN-BK	12	12.70	2.38	-	-														
 <p>N=3</p>	TPKN 1603 PDSR-MP	16	9.52	3.18	-	-	●	●	●	●										
	TPKN 1603 PDSR-MK	16	9.52	3.18	-	-														
	TPKN 2204 PDSR-MP	22	12.70	4.76	-	-	●	●	●	●										
	TPKN 2204 PDSR-MK	22	12.70	4.76	-	-														

Order example: 10 pieces SPMT 060304 BCP30M

- Available from stock
- On request
- Available 4th quarter 2018

Colours and execution of the original indexable inserts, may deviate from the illustration!

							Cutting materials											Assignment tools						
N = Number of cutting edges	Ordering code	l	d	s	d ₁	r	BCP20M	BCP25M	BCP30M	BCP35M	BCP40M	BCM35M	BCM40M	BCK20M	BCN10M	BCN15M	BWN10M		BCS35M	BCH05M	BCH10M	BCH30M		
<p>N=6</p>	WNEX 040304-MP	4	6.7	3.97	3.2	0.4		◻		◻													Page 78	
	WNEX 040304-MM	4	6.7	3.97	3.2	0.4						◻												
	WNEX 040304-MK	4	6.7	3.97	3.2	0.4								◻										
	WNEX 080608-RP	8	12.7	6.55	4.6	0.8		●		●														
	WNEX 080608-RM	8	12.7	6.55	4.6	0.8						●	●											
	WNEX 080608 RK	8	12.7	6.55	4.6	0.8								●										
	WNEX 080608-MN	8	12.7	6.55	4.6	0.8									●		●							
<p>N=7</p>	XEMT 040408-MP	4	12.7	4.76	4.6	0.8	●	●	●	●													Page 32	
	XEMT 040408-MM	4	12.7	4.76	4.6	0.8					●	●												
	XEMT 040408-MN	4	12.7	4.76	4.6	0.8									●									
	XEGT 040408-MT	4	12.7	4.76	4.6	0.8												●						
<p>N=7</p>	XEMW 040408-MP	4	12.7	4.76	4.6	0.8	●	●	●	●													Page 32	
	XEMW 040408-MM	4	12.7	4.76	4.6	0.8					●													
	XEMW 040408-MK	4	12.7	4.76	4.6	0.8								●										
	XEMW 040408-MH	4	12.7	4.76	4.6	0.8												●	●					

Order example: 10 pieces WNEX 040304-MP BCP25M

Description of grades page 114

- Available from stock
- On request
- ◻ Available 4th quarter 2018

News

- Torque wrench[®] with self-regulating torque load for each torx-size.
- DINA PLUS[®] torque wrench kit



Detailed information please refer from page 116

Face Milling 45°

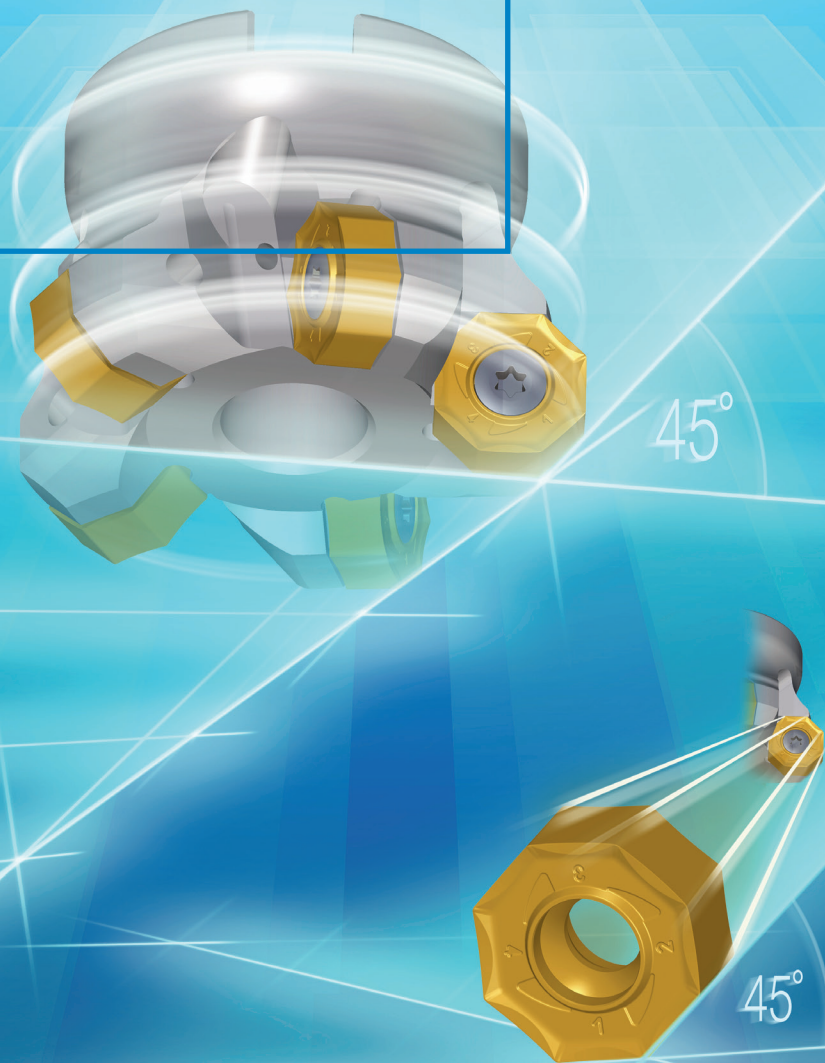

**Ø 50 mm - 250 mm
Face Milling Cutter
Insert size 05 and 08**

Special features:

- 16 cutting edges for increase of productivity
- Negativ basic geometry, thus extremely stable
- Effective positive cutting edge geometry, thus smooth cut
- Numbering of cutting edges for exact true running
- WIPER – geometry for qualitativ high-class surface. Best results if increasing cutting speed (approximately double vc. small cutting depth, approximately ap 0.7 mm, tooth feed approximately fz 0.25 mm with milling cutter diameter 63 mm)
- Big metal removal due to close division of the tools
- Uneven spacing leads to reduced vibration and extremely smooth running
- Cutting material diversity for optimal cutting results on a wide material range

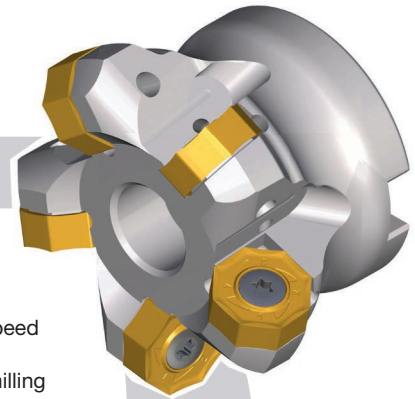

ON.. 05..

Insert geometry	Cutting depth [mm] a_p max ONM. 05	Feed [mm] f_z ONM. 05
MP	0.40 2 3.00	0.16 0.22 0.30
MM	0.40 2 3.00	0.12 0.18 0.25
MK	0.40 2 3.00	0.20 0.25 0.35
MH	0.40 1.50 2.50	0.10 0.16 0.26



ON.. 08..

Insert geometry	Cutting depth [mm] a_p max ONM. 08	Feed [mm] f_z ONM. 08
MP	1 3 5	0.2 0.27 0.45
MM	1 3 5	0.2 0.25 0.35
MK	1 3 5	0.2 0.35 0.60
FW	0.5 0.7 0.9	0.2 0.25 0.30

Cutting speed page 40-41

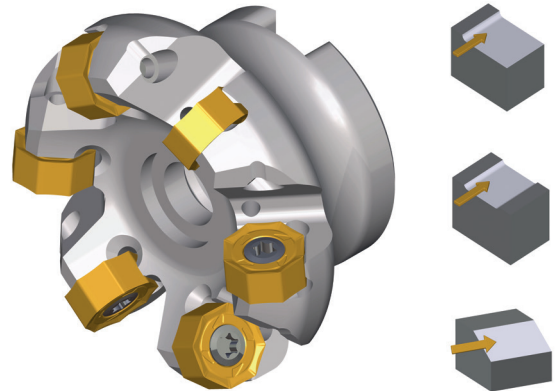
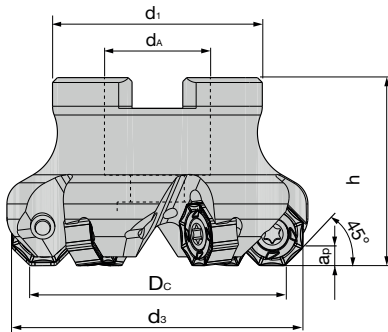
Face milling cutter 45° for ONMU 05../ metric



Dimensions in mm							Ordering code	Availability	Spare parts	
Dc	ds	d1	h	da	ap	z				
50	57.5	50	40	22	3	4	BF45 ON05.050 Z04	●	 Fixation screw AP06-40115 5131917	 Torque wrench IP20 5088521
50	57.5	50	40	22	3	6	BF45 ON05.050 Z06	●		
63	70.5	50	40	22	3	6	BF45 ON05.063 Z06	●		
63	70.5	50	40	22	3	8	BF45 ON05.063 Z08	●		
80	87.5	60	50	27	3	7	BF45 ON05.080 Z07	●		
80	87.5	60	50	27	3	10	BF45 ON05.080 Z10	●		
100	107.5	80	50	32	3	8	BF45 ON05.100 Z08	●		
100	107.5	80	50	32	3	12	BF45 ON05.100 Z12	●		
125	132.5	95	63	40	3	10	BF45 ON05.125 Z10	●		
125	132.5	95	63	40	3	16	BF45 ON05.125 Z16	●		

MA = 5Nm

Order example: 1 piece BF45 ON05.050 Z04

● Available from stock
○ On request

Face milling cutter 45° for ONMU 05.. / inch

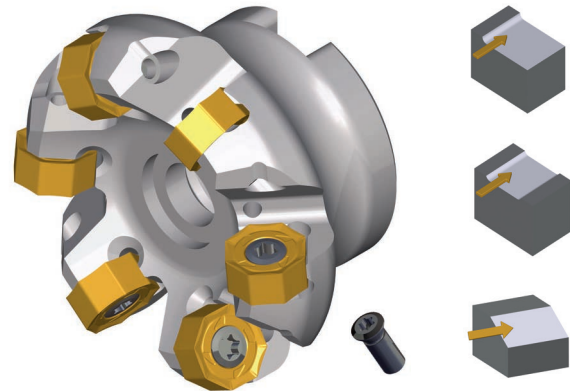
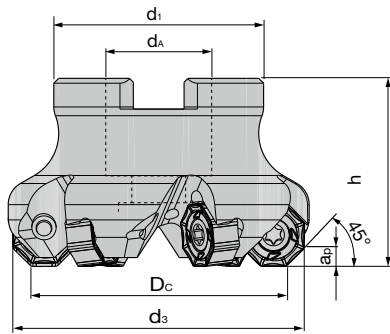

Dimensions in inch							Ordering code	Availability	Spare parts	
Dc	ds	d1	h	dA	ap	z ^o				
2.1	2.25	2.0	1.45	0.75	0.118	4	BFU45 SN12.2000 Z04	●	Fixation screw AP06-40115 5131917 MA= 5Nm	 Torque wrench IP20 5088521
2.1	2.25	2.0	1.45	0.75	0.118	6	BFU45 SN12.2000 Z06	●		
2.6	2.75	2.5	1.7	1.00	0.118	6	BFU45 SN12.2500 Z06	●		
2.6	2.75	2.5	1.7	1.00	0.118	8	BFU45 SN12.2500 Z08	●		
3.1	3.25	2.5	1.7	1.00	0.118	7	BFU45 SN12.3000 Z07	●		
3.1	3.25	2.5	1.7	1.00	0.118	10	BFU45 SN12.3000 Z10	●		
4.1	4.25	3.75	2.2	1.50	0.118	8	BFU45 SN12.4000 Z08	●		
4.1	4.25	3.75	2.2	1.50	0.118	12	BFU45 SN12.4000 Z12	●		
5.1	5.25	3.75	2.45	1.50	0.118	10	BFU45 SN12.5000 Z10	●		
5.1	5.25	3.75	2.45	1.50	0.118	16	BFU45 SN12.5000 Z16	●		
6.1	6.25	5.0	2.45	2.00	0.118	12	BFU45 SN12.6000 Z12 NC	●		
6.1	6.25	5.0	2.45	2.00	0.118	20	BFU45 SN12.6000 Z20 NC	○		
8.1	8.25	6.0	2.45	2.50	0.118	18	BFU45 SN12.8000 Z18 NC	●		
10.1	10.25	7.5	2.45	2.50	0.118	20	BFU45 SN12.10000 Z20 NC	○		

Order example: 1 piece BFU45 SN12.2000 Z04

NC = no coolant



Insert Size 05							Cutting materials Ident No.										
N = Number of cutting edges	Ordering code	l	d	s	d1	r	BCP20M	BCP25M	BCP30M	BCP35M	BCP40M	BCM35M	BCM40M	BCK15M	BCK20M	BCH10M	BCH30M
							 N = 16	ONMU 050608 SN-MP	5.24	12.7	5.8	5.45	0.8		●		●
ONMU 050608 SN-MM	5.24	12.7	5.8	5.45	0.8							●	●				
ONMU 050608 SN-MK	5.24	12.7	5.8	5.45	0.8										●		
ONMU 050608 SN-MH	5.24	12.7	5.8	5.45	0.8												●

Order example: 10 pieces ONMU 050608 SN-MP BCP25M
 Description of grades page 114

● Available from stock
 ○ On request

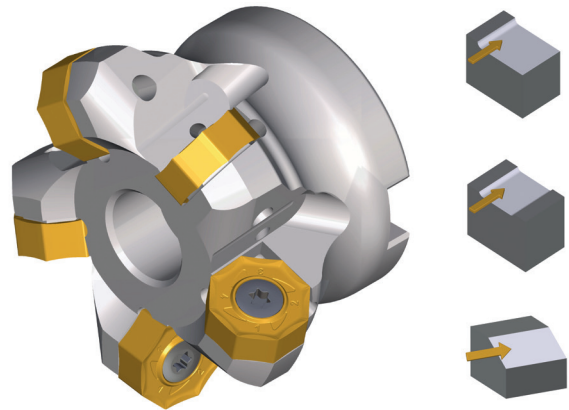
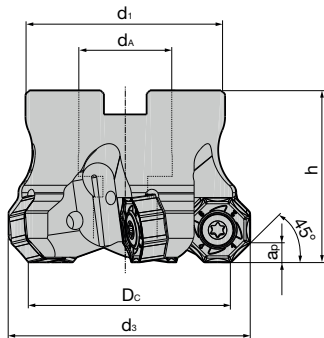
Face milling cutter 45° for ONMU08.. / metric





Dimensions in mm							Ordering code	Availability	Spare parts	
Dc	ds	d1	h	dA	ap	z				
50	60	46	50	22	5	4	BF45 ON08.050 Z04	●	 Fixation screw A02-60160 6401270 MA = 6Nm  Torque wrench T25 5088518	
63	73	58	50	27	5	5	BF45 ON08.063 Z05	●		
66	73	58	50	27	5	5	BF45 ON08.066 Z05	○		
80	90	78	50	32	5	6	BF45 ON08.080 Z06	●		
80	90	78	50	32	5	7	BF45 ON08.080 Z07	●		
100	110	78	50	32	5	7	BF45 ON08.100 Z07	●		
100	110	78	50	32	5	9	BF45 ON08.100 Z09	●		
125	135	90	63	40	5	9	BF45 ON08.125 Z09	●		
125	135	90	63	40	5	11	BF45 ON08.125 Z11	●		
160	170	90	63	40	5	11	BF45 ON08.160 Z11	●		
200	210	130	65	60	5	16	BF45 ON08.200 Z16 NC	●		
250	260	190	75	60	5	18	BF45 ON08.250 Z18 NC	●		

Order example: 1 piece BF45 ON08.050 Z04

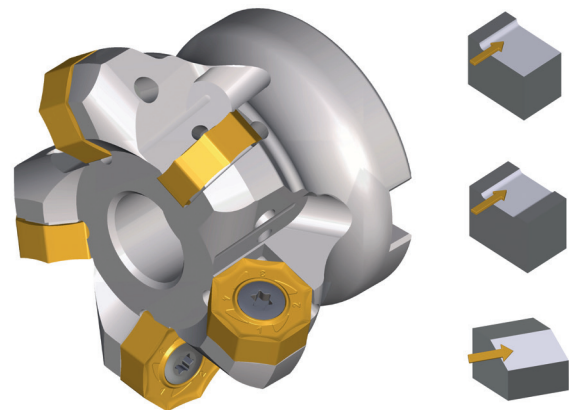
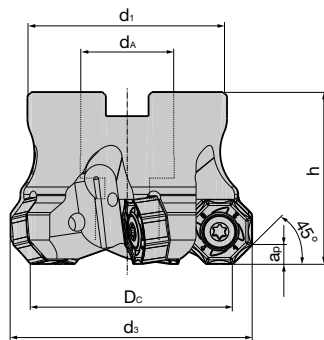
Face milling cutter 45° for ONMU08.. /inch



Dimensions in inch							Ordering code	Availability	Spare parts	
Dc	ds	d1	h	dA	ap	z				
2.0	2.4	2.0	2.0	0.75	0.197	4	BFU45 ON08.2000 Z04	●	 Fixation screw A02-60160 6401270 MA = 6Nm  Torque wrench T25 5088518	
2.5	2.9	2.25	2.0	1.00	0.197	5	BFU45 ON08.2500 Z05	●		
3.0	3.4	2.75	2.0	1.25	0.197	6	BFU45 ON08.3000 Z06	●		
3.0	3.4	2.75	2.0	1.25	0.197	7	BFU45 ON08.3000 Z07	●		
4.0	4.4	3.75	2.25	1.50	0.197	7	BFU45 ON08.4000 Z07	●		
4.0	4.4	3.75	2.25	1.50	0.197	9	BFU45 ON08.4000 Z09	●		
5.0	5.4	3.75	2.5	1.50	0.197	9	BFU45 ON08.5000 Z09	●		
5.0	5.4	3.75	2.5	1.50	0.197	11	BFU45 ON08.5000 Z11	●		
6.0	6.4	5.0	2.0	2.00	0.197	11	BFU45 ON08.6000 Z11	●		

Order example: 1 piece BFU45 ON08.2000 Z04

● Available from stock
○ On request

Insert Size 08							Cutting materials Ident No.										
N = Number of cutting edges	Ordering code	l	d	s	d ₁	r	BCP20M	BCP25M	BCP30M	BCP35M	BCP40M	BCM35M	BCM40M	BCK15M	BCK20M	BCH10M	BCH30M
								ONMU 080608 SN-MP	8	19	6.95	6.75	0.8	●	●	●	●
ONMU 080608 SN-MM	8	19	6.95	6.75	0.8							●	●				
ONMU 080608 SN-MK	8	19	6.95	6.75	0.8									●	●		
ONMQ 0806-FW	8	19.1	6.95	6.75	0.8							●					○

N = 16

Order example: 10 pieces ONMU 080608 SN-MP BCP20M

ETAtec 45P

Multi Functional

www.boehlerit.com

- Ø 50 mm - 200 mm Face Milling Cutter
Insert size 04 (13)
- Ø 2" - 8" Face Milling Cutter
Insert size 04 (13)
- Ø 25 mm - 40 mm End Milling Cutter
Insert size 04 (13)
- Ø 25 mm - 40 mm Screw on type
Insert size 04 (13)

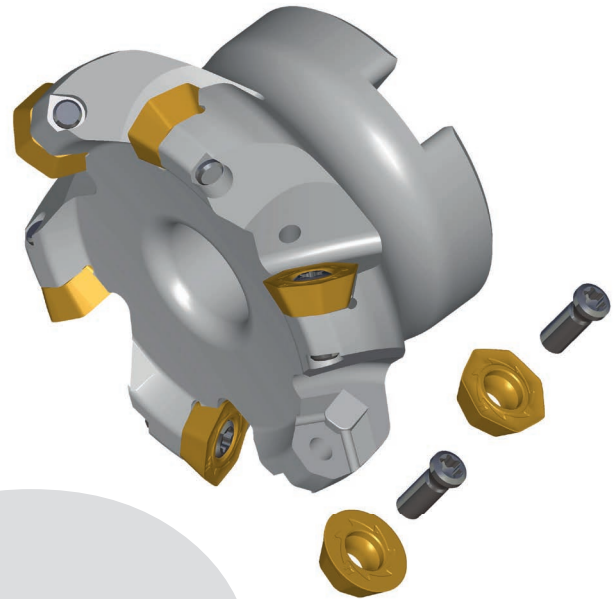

Special features:

- Multifunctional tool system for highest productivity
- 1 basic body for 2 machining processes = multifunctional
- Saving of tool holders due to multifunctional tool system
- Positive basic geometry, therefore easy cutting
- 7 cutting edges for increase of productivity on face milling
- Round insert with 7 cutting edges through defined geometrical design
- Marking of the cutting edges for exact concentricity
- High metal removal also on inefficient old machines due to small power consumption
- Uneven spacing leads to reduced vibration and extremely smooth running
- Diversity of cutting materials for optimal cutting results on a wide material range

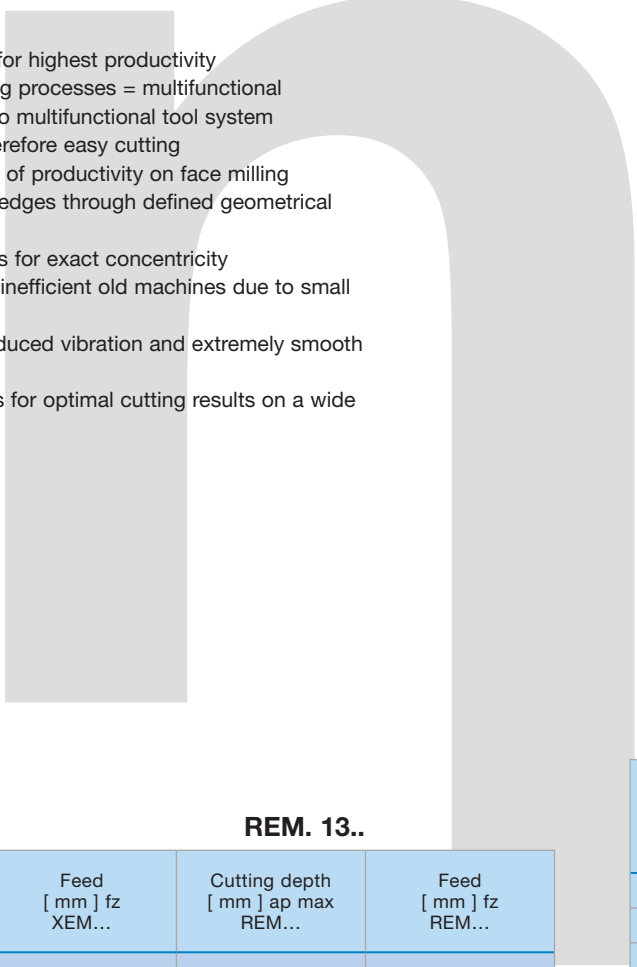

Ramping angle



XEM. 04..



REM. 13..

Insert geometry	Cutting depth [mm] ap max XEM...			Feed [mm] fz XEM...			Cutting depth [mm] ap max REM...			Feed [mm] fz REM...		
	1.00	2.50	4.00	0.15	0.20	0.30	1.00	1.50	3.20	0.20	0.45	0.85
MP	1.00	2.50	4.00	0.15	0.20	0.30	1.00	1.50	3.20	0.20	0.45	0.85
MM	1.00	2.50	4.00	0.12	0.18	0.25	1.00	1.50	3.20	0.20	0.35	0.75
MK	1.00	2.50	4.00	0.20	0.23	0.30	1.00	1.50	3.20	0.25	0.55	1.00
MN	1.00	3.00	4.00	0.12	0.20	0.30	---	---	---	---	---	---
MT	1.00	2.00	3.00	0.10	0.13	0.20	---	---	---	---	---	---
MH	0.60	1.00	2.00	0.10	0.16	0.25	0.50	1.00	3.00	0.20	0.35	0.70

Diameter Milling cutter	Ramping angle milling cutter α max.
Ø 25	6.84°
Ø 32	5.36°
Ø 36	4.76°
Ø 40	4.29°
Ø 50	3.43°
Ø 52	3.30°
Ø 63	2.73°
Ø 66	2.60°
Ø 80	2.15°
Ø 100	1.72°
Ø 125	1.37°
Ø 160	1.07°
Ø 200	0.86°

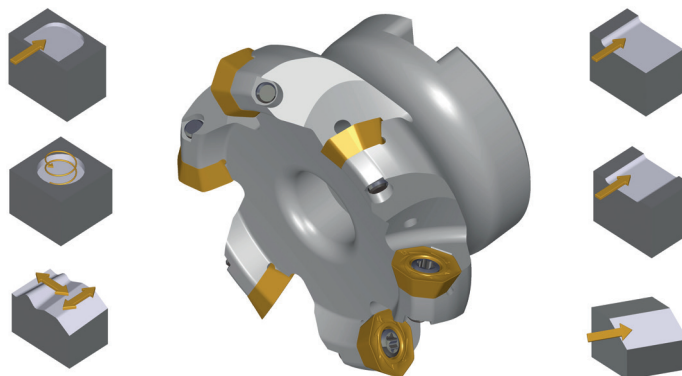
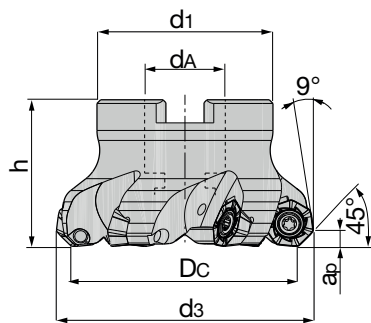
Face milling cutter 45° for XE.. & RE.. / metric





Dimensions in mm							Ordering code	Availability	Spare parts	
Dc	d3	dA	d1	h	ap	z [♻]				
50	57.5	22	43	40	4	5	BF45 XE04.050 Z05	●	 Fixation screw AP02-40054 5085714 $M_A = 3Nm$	 Torque wrench IP15 5088520
52	59.5	22	43	40	4	5	BF45 XE04.052 Z05	●		
63	70.5	22	48	40	4	5	BF45 XE04.063 Z05	●		
63	70.5	22	48	40	4	6	BF45 XE04.063 Z06	●		
66	73.5	22	48	40	4	6	BF45 XE04.066 Z06	●		
80	87.5	27	60	50	4	6	BF45 XE04.080 Z06	●		
80	87.5	27	60	50	4	8	BF45 XE04.080 Z08	●		
100	107.5	32	78	50	4	8	BF45 XE04.100 Z08	●		
100	107.5	32	78	50	4	10	BF45 XE04.100 Z10	●		
125	132.5	40	90	60	4	10	BF45 XE04.125 Z10	●		
125	132.5	40	90	60	4	12	BF45 XE04.125 Z12	●		
160	167.5	40	90	65	4	10	BF45 XE04.160 Z10 NC	●		
160	167.5	40	90	65	4	14	BF45 XE04.160 Z14 NC	●		
200	207.5	60	140	65	4	16	BF45 XE04.200 Z16 NC	●		

Order example: 1 piece BFU45 XE04.050 Z05

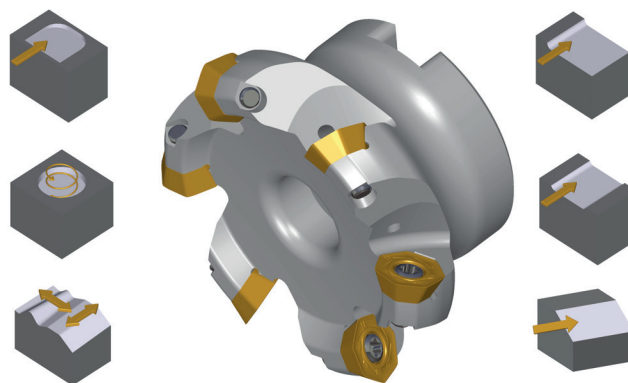
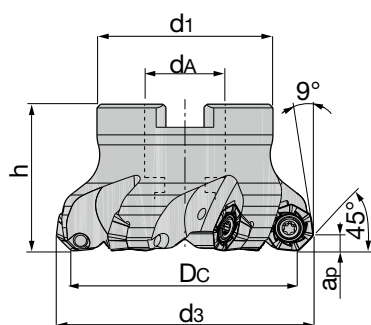
Face milling cutter 45° for XE.. & RE.. / inch



Dimensions in inch							Ordering code	Availability	Spare parts	
Dc	d3	dA	d1	h	ap	z [♻]				
2.0	2.3	1.75	1.75	0.75	0.157	5	BFU45 XE04.2000 Z05	□	 Fixation screw AP02-40054 5085714 $M_A = 3Nm$	 Torque wrench IP15 5088520
2.5	2.8	2.0	1.75	1.0	0.157	5	BFU45 XE04.2500 Z05	□		
2.5	2.8	2.0	1.75	1.0	0.157	6	BFU45 XE04.2500 Z06	○		
3.0	3.3	2.75	2.0	1.25	0.157	6	BFU45 XE04.3000 Z06	□		
3.0	3.3	2.75	2.0	1.25	0.157	8	BFU45 XE04.3000 Z08	□		
4.0	4.3	3.5	2.0	1.5	0.157	8	BFU45 XE04.4000 Z08	□		
4.0	4.3	3.5	2.0	1.5	0.157	10	BFU45 XE04.4000 Z10	□		
5.0	5.3	3.75	2.5	1.5	0.157	10	BFU45 XE04.5000 Z10	□		
5.0	5.3	3.75	2.5	1.5	0.157	12	BFU45 XE04.5000 Z12	□		
6.0	6.3	5.0	2.5	2.0	0.157	10	BFU45 XE04.6000 Z10 NC	□		
6.0	6.3	5.0	2.5	2.0	0.157	14	BFU45 XE04.6000 Z14 NC	○		
8.0	8.3	6.0	2.5	2.5	0.157	16	BFU45 XE04.8000 Z16 NC	○		

Order example: 1 piece BFU45 XE04.2000 Z05

Cutting speed page 40-41

NC = no coolant

- Available from stock
- On request
- Available 4th quarter 2018

ETAtec 45P

Multi Functional

www.boehlerit.com

End milling cutter 45° / XE.. & RE.. / metric

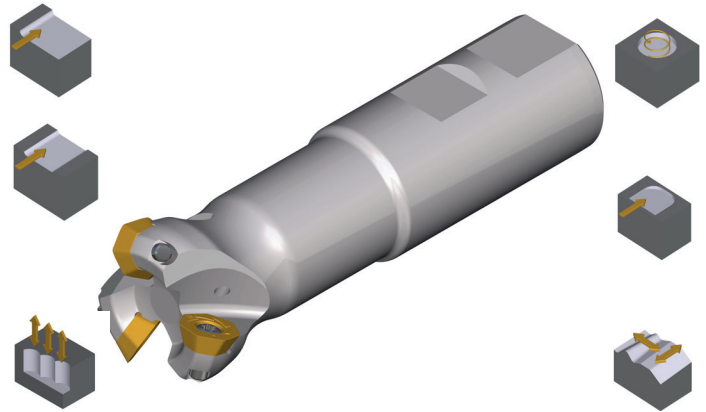
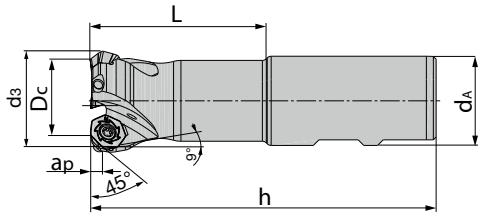

Dimensions in mm								Ordering code	Availability	Spare parts	
Dc	d3	dA	h	L	ap	z					
25	32.5	25	106	50	4	2	BE45 XE04.025 Z02	●	Fixation screw AP02-40082 5122796 $M_A = 3Nm$	 Torque wrench IP15 5088520	
32	39.5	32	124	64	4	3	BE45 XE04.032 Z03	●			
36	43.5	32	124	64	4	3	BE45 XE04.036 Z03	●	Fixation screw AP02-40054 5085714 $M_A = 3Nm$		
40	47.5	32	130	65	4	4	BE45 XE04.040 Z04	●			

Order example: 1 piece BE45 XE04.025 Z02

Screw on type 45° / XE.. & RE.. / metric

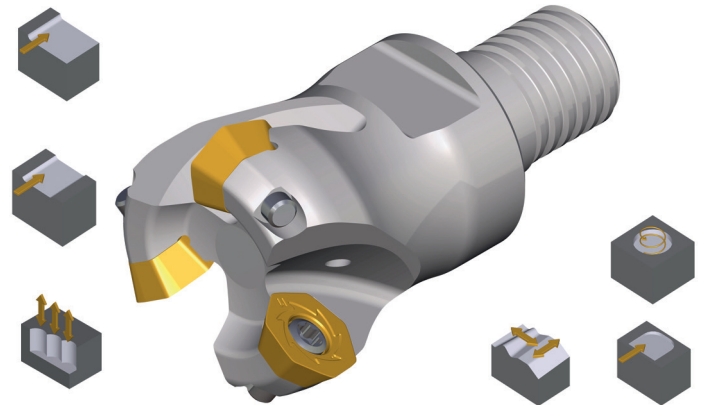
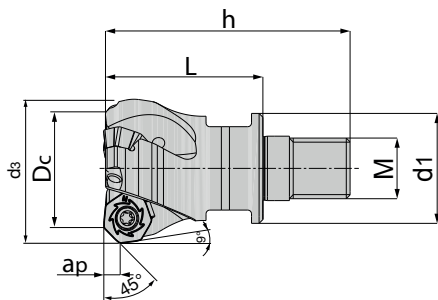

Dimensions in mm								Ordering code	Availability	Spare parts	
Dc	d3	d1	L	h	ap	M	z				
25	32.5	21	32	54	4	12	2	BS45 XE04.025 Z02 M12	●	Fixation screw AP02-40082 5122796 $M_A = 3Nm$	 Torque wrench IP15 5088520
32	39.5	29	42	65	4	16	3	BS45 XE04.032 Z03 M16	●		
40	47.5	29	43	66	4	16	4	BS45 XE04.040 Z04 M16	●	Fixationscrew AP02-40054 5085714 $M_A = 3Nm$	

Order example: 1 piece BS45 XE04.025 Z02 M12

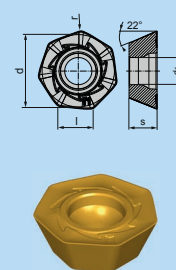
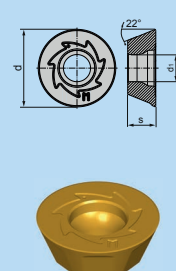
Insert Size 04 / 13							Cutting materials													
N = Number of cutting edges	Ordering code	l	d	s	d ₁	r	BCP20M	BCP25M	BCP30M	BCP35M	BCP40M	BCM35M	BCM40M	BCK15M	BCK20M	BCN15M	BCS35M	BCH05M	BCH10M	BCH30M
																				
N = 7	XEMT 040408-MP	4	12.7	4.76	4.6	0.8	●	●	●	●										
	XEMT 040408-MM	4	12.7	4.76	4.6	0.8						●	●							
	XEMT 040408-MN	4	12.7	4.76	4.6	0.8										●				
	XEGT 040408-MT	4	12.7	4.76	4.6	0.8												●		
	XEMW 040408-MP	4	12.7	4.76	4.6	0.8		●	●	●	●									
	XEMW 040408-MM	4	12.7	4.76	4.6	0.8							●							
	XEMW 040408-MK	4	12.7	4.76	4.6	0.8									●					
	XEMW 040408-MH	4	12.7	4.76	4.6	0.8													●	●
																				
N = 7	REMW 1304MO-MP	-	13.2	4.76	4.6	-	●	●	●	●										
	REMW 1304MO-MM	-	13.2	4.76	4.6	-							●							
	REMW 1304MO-MK	-	13.2	4.76	4.6	-								●	●					
	REMW 1304MO-MH	-	13.2	4.76	4.6	-													●	●

Order example: 10 pieces XEMT 040408-MP BCP20M

Ø 50 mm - 250 mm
Face Milling Cutter
Insert size 12

Ø 2" - 10"
Face Milling Cutter
Insert size 12



Special features:

- 8 cutting edges for increase of productivity at big cutting depths
- Negative basic geometry. therefore extremely stable
- Effective positive cutting edge geometry. therefore smooth cut
- Marking of the cutting edges for exakt concentricity
- WIPER geometry for qualitativ high-class surface
- High metal removal. due to narrow and very narrow division of the tools
- Uneven spacing leads to reduced vibration and extremely smooth running
- Diversity of cutting materials for optimal cutting results on a wide material range



SN.. 12..

Insert geometry	Cutting depth [mm] a_p max	Feed [mm] f_z
MP	1 4 6.5	0.18 0.26 0.35
MM	1 4 6.5	0.15 0.23 0.28
MK	1 4 6.5	0.20 0.3 0.40
FW	0.2 0.5 0.7	0.15 0.27 0.40

Cutting speed page 40-41

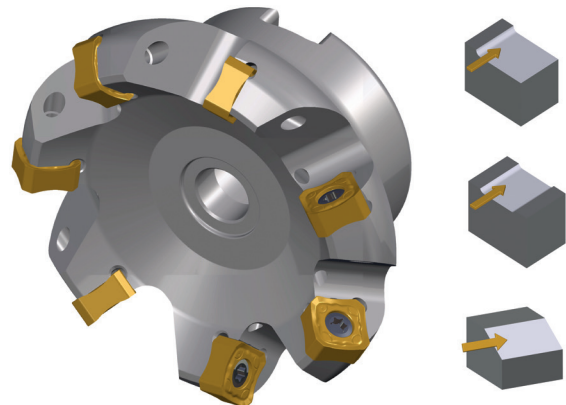
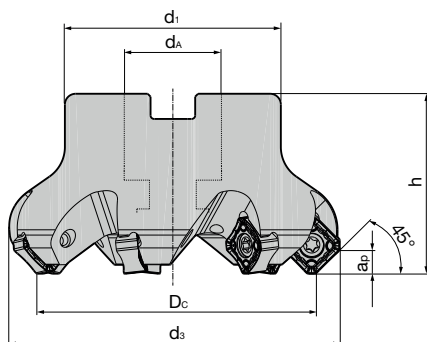
Face milling cutter 45° for SN.. 12.. / metric



Dimensions in mm							Ordering code	Availability	Spare parts	
Dc	d ₃	d ₁	h	d _A	a _p	z \odot				
50	63.4	50	40	22	6.5	4	BF45 SN12.050 Z04	●	 Fixation screw AP06-40115 5131917 M _A = 5Nm	 Torque wrench IP20 5088521
50	63.4	50	40	22	6.5	6	BF45 SN12.050 Z06	●		
63	76.4	50	40	22	6.5	5	BF45 SN12.063 Z05	○		
63	76.4	50	40	22	6.5	6	BF45 SN12.063 Z06	○		
63	76.4	50	40	22	6.5	8	BF45 SN12.063 Z08	●		
80	93.4	60	50	27	6.5	6	BF45 SN12.080 Z06	○		
80	93.4	60	50	27	6.5	7	BF45 SN12.080 Z07	●		
80	93.4	60	50	27	6.5	10	BF45 SN12.080 Z10	●		
100	113.4	80	50	32	6.5	8	BF45 SN12.100 Z08	●		
100	113.4	80	50	32	6.5	12	BF45 SN12.100 Z12	●		
125	138.4	95	63	40	6.5	8	BF45 SN12.125 Z08	○		
125	138.4	95	63	40	6.5	10	BF45 SN12.125 Z10	●		
125	138.4	95	63	40	6.5	16	BF45 SN12.125 Z16	●		
160	173.4	115	63	40	6.5	10	BF45 SN12.160 Z10 NC	○		
160	173.4	115	63	40	6.5	12	BF45 SN12.160 Z12	○		
160	173.4	115	63	40	6.5	12	BF45 SN12.160 Z12 NC	●		
160	173.4	115	63	40	6.5	20	BF45 SN12.160 Z20 NC	○		
200	213.4	164	63	60	6.5	18	BF45 SN12.200 Z18 NC	●		
200	213.4	164	63	60	6.5	26	BF45 SN12.200 Z26 NC	○		
250	263.4	184	63	60	6.5	20	BF45 SN12.250 Z20 NC	●		
250	263.4	184	63	60	6.5	30	BF45 SN12.250 Z30 NC	○		

Order example: 1 piece BF45 SN12.050 Z04

NC = no coolant

- Available from stock
- On request

Face milling cutter 45° for SN.. 12.. / inch

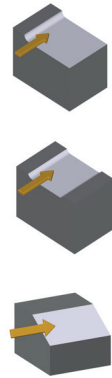
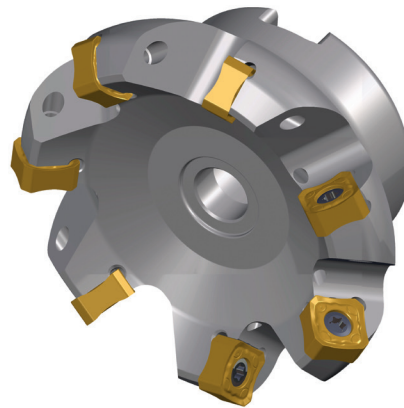
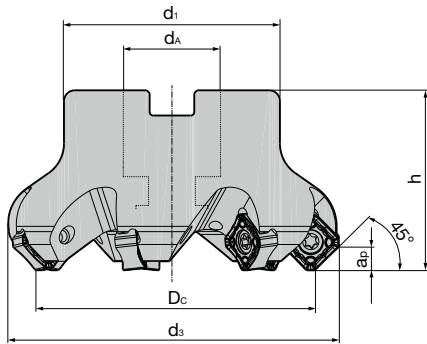

Dimensions in inch							Ordering code	Availability	Spare parts	
Dc	ds	d1	h	dA	ap	z _z				
2.0	2.5	2.0	1.5	0.75	0.256	4	BFU45 SN12.2000 Z04	●	 Fixation screw AP06-40115 5131917 MA= 5Nm	 Torque wrench IP20 5088521
2.0	2.5	2.0	1.5	0.75	0.256	6	BFU45 SN12.2000 Z06	●		
2.5	3	2.5	1.75	1.0	0.256	6	BFU45 SN12.2500 Z06	○		
2.5	3	2.5	1.75	1.0	0.256	8	BFU45 SN12.2500 Z08	○		
3.0	3.5	2.5	1.75	1.0	0.256	7	BFU45 SN12.3000 Z07	●		
3.0	3.5	2.5	1.75	1.0	0.256	10	BFU45 SN12.3000 Z10	●		
4.0	4.5	3.75	2.25	1.5	0.256	8	BFU45 SN12.4000 Z08	●		
4.0	4.5	3.75	2.25	1.5	0.256	12	BFU45 SN12.4000 Z12	●		
5.0	5.5	3.75	2.5	1.5	0.256	10	BFU45 SN12.5000 Z10	●		
5.0	5.5	3.75	2.5	1.5	0.256	16	BFU45 SN12.5000 Z16	●		
6.0	6.5	5.0	2.5	2.0	0.256	12	BFU45 SN12.6000 Z12 NC	●		
6.0	6.5	5.0	2.5	2.0	0.256	20	BFU45 SN12.6000 Z20 NC	○		
8.0	8.5	6.0	2.5	2.5	0.256	18	BFU45 SN12.8000 Z18 NC	●		
10	10.5	7.5	2.5	2.5	0.256	20	BFU45 SN12.10000 Z20 NC	○		

Order example: 1 piece BFU45 SN12.2000 Z04

NC = no coolant

Insert Size 12							Cutting materials Ident No.											
N = Number of cutting edges	Ordering code	l	d	s	d ₁	r	BCP20M	BCP25M	BCP30M	BCP35M	BCP40M	BCM35M	BCM40M	BCK15M	BCK20M	BCN10M	BWN10M	
							 N = 8	SNMX 1206 ANSN-MP	12.70	12.70	6.35	5.2	-	●	●	●	●	
SNMX 1206 ANSN-MM	12.70	12.70	6.35	5.2	-							●	●					
SNMX 1206 ANSN-MK	12.70	12.70	6.35	5.2	-									●	●			
SNEX 1206-FW	12.70	12.70	6.35	5.2								●						

Order example: 10 pieces SNMX 1206 ANSN-MP BCP20M

Ø 40 mm - 160 mm
Face Milling Cutter
Insert size 12

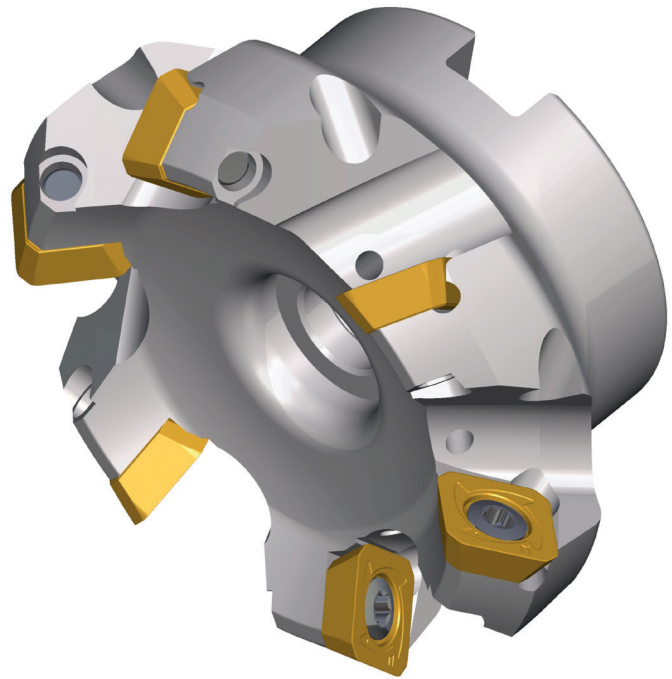

Special features:

- Positive basic geometry, therefore easy cutting
- 4 cutting edges for increase of productivity
- Marking of the cutting edges for exact concentricity
- High metal removal also on inefficient old machines due to small power consumption
- Uneven spacing leads to reduced vibration and extremely smooth running
- Diversity of cutting materials for optimal cutting results on a wide material range

SE.. 12..

Insert geometry	Cutting depth [mm] a_p max	Feed [mm] f_z
MP	1 4 6	0.16 0.25 0.35
MM	1 4 6	0.10 0.2 0.30
MK	1 4 6	0.18 0.3 0.40
ALC	0.7 4 5	0.08 0.18 0.28

Face milling cutter 45° for SE..12.. / metric

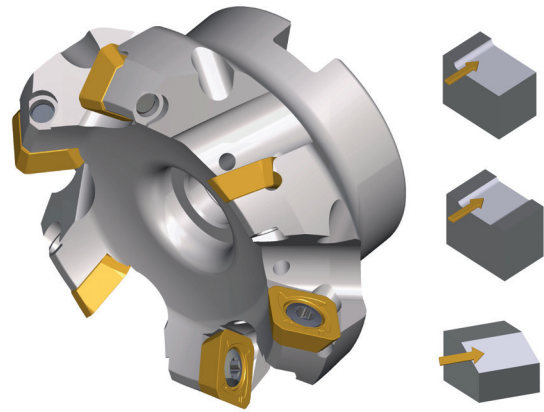
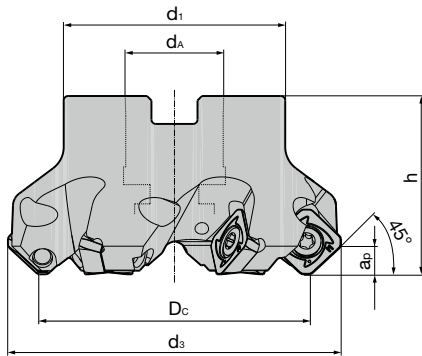

Dimensions in mm							Ordering code	Availability	Spare parts	
Dc	ds	d1	h	dA	ap	z [⊙]				
40	53	32	40	16	6	4	BF45 SE12.040 Z04	●	 Fixation screw AP13-45108 5085713 MA= 5Nm	 Torque wrench IP20 5088521
50	63	50	40	22	6	5	BF45 SE12.050 Z05	●		
63	76	50	40	22	6	5	BF45 SE12.063 Z05	●		
63	76	50	40	22	6	6	BF45 SE12.063 Z06	●		
63	76	50	40	22	6	7	BF45 SE12.063 Z07	●		
80	93	52	50	27	6	6	BF45 SE12.080 Z06	●		
80	93	52	50	27	6	7	BF45 SE12.080 Z07	●		
100	113	78	50	32	6	6	BF45 SE12.100 Z06	●		
100	113	78	50	32	6	8	BF45 SE12.100 Z08	●		
125	138	90	63	40	6	10	BF45 SE12.125 Z10	●		
160	173	114	63	40	6	12	BF45 SE12.160 Z12 NC	●		

Order Example: 1 piece BF45 SE12.040 Z04

NC = no coolant

Insert Size 12							Cutting materials Ident No.											
N = Number of cutting edges	Ordering code	l	d	s	d1	r	BCP20M	BCP25M	BCP30M	BCP35M	BCP40M	BCM35M	BCM40M	BCK15M	BCK20M	BCN10M	BWN10M	
							 SEHT 1204 AFFN-ALC N = 4	12.70	12.70	4.76	5.5	-						
 SEKT 1204 AFSN-MP SEKT 1204 AFEN-MM N = 4	12.70	12.70	4.76	5.5	-	●	●	●	●			●	●					
 SEKW 1204 AFSN-MP SEKW 1204 AFEN-MM SEKW 1204 AFSN-MK N = 4	12.70	12.70	4.76	5.5	-		●	●	●	●				●				

Order example: 10 pieces SEHT 1204 AFFN-ALC BCN10M

Cutting Speed Recommendations for Milling Cutter 45°

Material group	Insert grade				BCP20M P20	BCP25M P25	BCP30M P30	BCP35M P35	BCP40M P40
	ISO Code		Dry machining	Wet machining					
	Material								
P	Structural steel		●	○	190-290	190-290	160-240	150-230	100-220
	Heat treated steel		●	○	160-230	160-230	140-190	130-180	145-215
	Tool steel		●	○	145-210	145-210	120-175	110-160	130-190
	Heat treated steel	high strength	●	○	110-170	110-170	100-160		
M	Stainless steel	austenitic	●	○		90-150		80-140	70-130
		austenitic hardened	●	○		60-110			
K	Grey cast iron		●	○		140-300			
	Nodular graphite cast iron		●	○		100-160			
N	Aluminium		●	○					
	Copper and copper alloys		●	○					
S	Heat resistant alloys		○	●					
	Titanium alloys		○	●					
H		Hardness							
	Chilled cast iron	300-600 HB	●	○					
	Hardened steel	45-52 HRC	●	○	100-150	100-150			
	Hardened steel	53-58 HRC	●	○	100-150	100-150			
	Hardened steel	59-63 HRC	●	○	100-150	100-150			

- recommended application
- alternative application reduced by 30 - 50 %

BCM35M M35	BCM40M M40	BCK15M K15	BCK20M K20	BCN10M N10	BCN15M N15	BWN10M N10	BCS35M S35	BCH03M	BCH05M	BCH10M	BCH23M	BCH30M
			200-300							200-350		
			180-250							180-300		
			160-220							180-250		
			120-180							150-250		
110-180	100-160						100-150					
80-130	70-120						80-120					
		180-360	150-320							180-400		
		140-250	110-180							150-250		
				500-3000	500-3000	400-2500						
				160-500	160-500	120-400						
	30-60						30-80					
	30-60						30-80					
		80-120	80-120						70-100	65-95		60-90
									100-150	95-145		80-120
									70-80	65-75		-
									-	-		-

ETAtec 45P -
Face milling made easy



Milling 90°

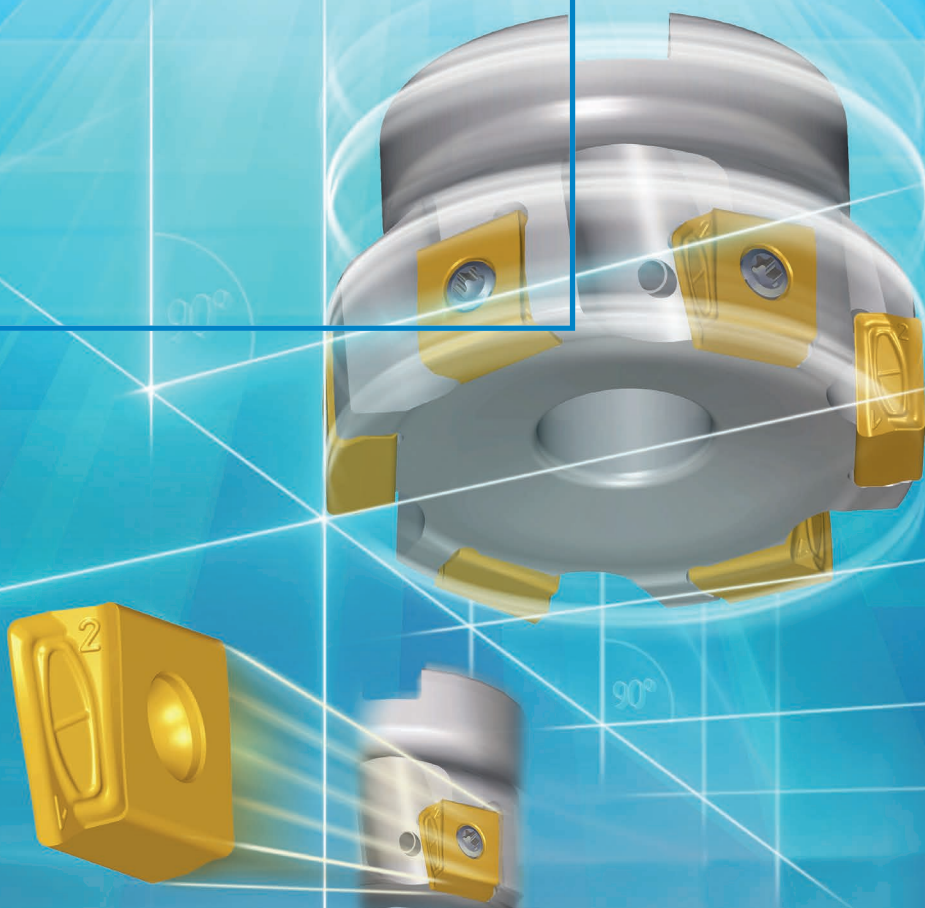

BETAtec 90P Feed

Multi Functional

www.boehlerit.com

Ø 40 mm - 160 mm Face Milling Cutter
Insert size 10 and 18

Ø 1 1/2" - 5" Face Milling Cutter
Insert size 10 and 18

Ø 16 mm - 40 mm End Milling Cutter
Insert size 10 and 18

Ø 1/2" - 1 1/2" End Milling Cutter
Insert size 10 und 18

Ø 16 mm - 40 mm Screw on type
Insert size 10

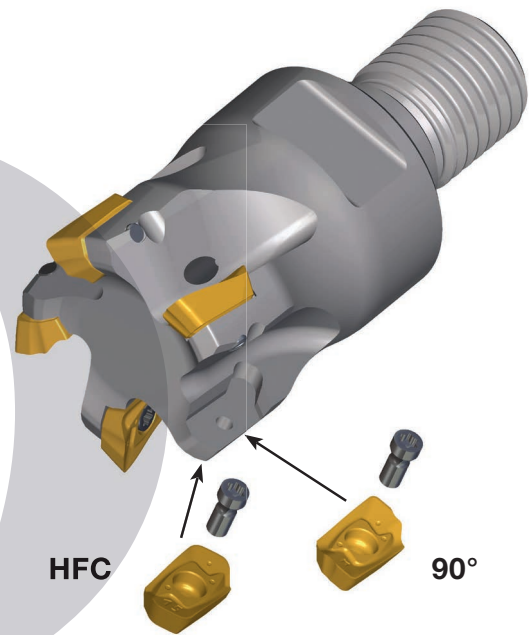

Special features: Milling 90°

- Multifunctional tool system for highest productivity
- 1 basic body for 2 machining methods = multi functional
- Facilitation of storage and tool procurement through less articles
- Exact 90° shoulder up to 1/2 cutting edge length on all diameters
- Helix cutting edge for small cutting forces
- Vibration damping concept for big blade overhang in combination with solid carbide extensions
- Reduction of machining costs due to stepless shoulder milling
- High cutting rates also on inefficient machines

Special features: Milling HFC

- High cutting rates with good process security
- Smooth cut also in slot milling
- Functionality of both cutting edges guaranteed to 100 % also on machining in the „chip tank“
- Optimal distribution of cutting forces due to special cutting edge geometry

HFC Ramping angle

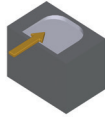

Diameter Milling cutter	Angle of dip HFC milling cutter LDMX10....
Ø 16	8.8°
Ø 20	6.1°
Ø 25	4.4°
Ø 32	3.2°
Ø 40	2.4°
Ø 50	1.9°
Ø 63	1.4°
Ø 80	1.1°

90° Ramping angle

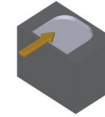

Diameter Milling cutter	Angle of dip 90° milling cutter LDMX10....	Angle of dip 90° milling cutter LDMX18....
Ø 16	18.0°	-
Ø 20	12.2°	-
Ø 25	8.7°	-
Ø 32	6.2°	-
Ø 40	4.6°	5°
Ø 50	3.5°	4°
Ø 63	2.7°	3.18°
Ø 80	2.1°	2.51°
Ø 100	-	2.0°
Ø 125	-	1.6°
Ø 160	-	1.25°

HFC High Feed cutting parameter

LD.. 10..

Insert geometry	Cutting depth [mm] a_p max LD..10	Feed [mm] f_z LD..10
MPH	0.4 0.9 1.4	0.6 1 1.5
MMH	0.4 0.9 1.4	0.5 0.9 1.3
MKH	0.4 0.9 1.4	0.6 1.2 1.5

90° Milling parameter

LD.. 10..

Insert geometry	Cutting depth [mm] a_p max LD..10	Feed [mm] f_z LD..10
MP	1 3 9	0.1 0.18 0.25
MM	1 3 9	0.1 0.15 0.20
MK	1 3 9	0.15 0.20 0.27
MN	1 3 9	0.1 0.14 0.26
MT	1 3 9	0.1 0.15 0.20

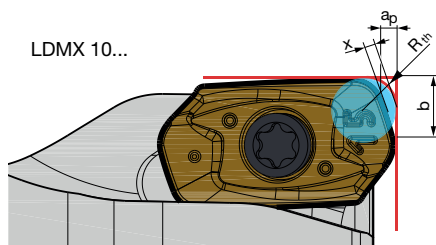

LDM..	R_{th}	a_p	x	b
10	2.2	1.5	0.4	3.52



90° Milling parameter

LD.. 18..

Insert geometry	Cutting depth [mm] a_p max LD..18	Feed [mm] f_z LD..18
MP	1 6 17	0.1 0.19 0.25
MM	1 6 17	0.1 0.15 0.22
MK	1 6 17	0.15 0.21 0.26
RP	1 6 17	0.15 0.22 0.28
RK	1 6 17	0.15 0.24 0.30

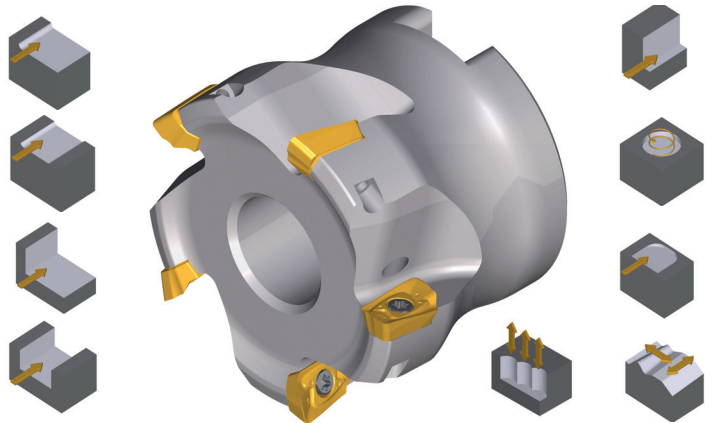
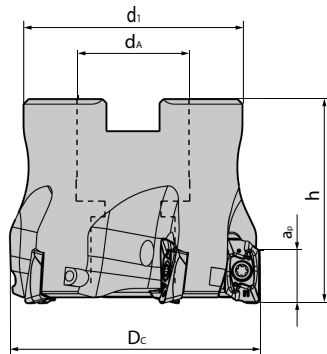
Face milling cutter 90° / LDMX 10 / metric





Dimensions in mm							Ordering code	Availability	Spare parts	
Dc	dA	d1	h	ap/90	ap/HFC	z [✱]				
40	16	35	40	9	1.4	4	BF90 LD10.040 Z04	●	 Fixation screw AP02-25068 5085706 MA= 2Nm	 Torque wrench IP8 5088519
40	16	35	40	9	1.4	6	BF90 LD10.040 Z06	●		
50	22	43	40	9	1.4	5	BF90 LD10.050 Z05	●		
50	22	43	40	9	1.4	7	BF90 LD10.050 Z07	●		
63	22	48	40	9	1.4	6	BF90 LD10.063 Z06	●		
63	22	48	40	9	1.4	8	BF90 LD10.063 Z08	●		
80	27	60	50	9	1.4	10	BF90 LD10.080 Z10	●		

Order example: 10 pieces BE90 LD10.040 Z04

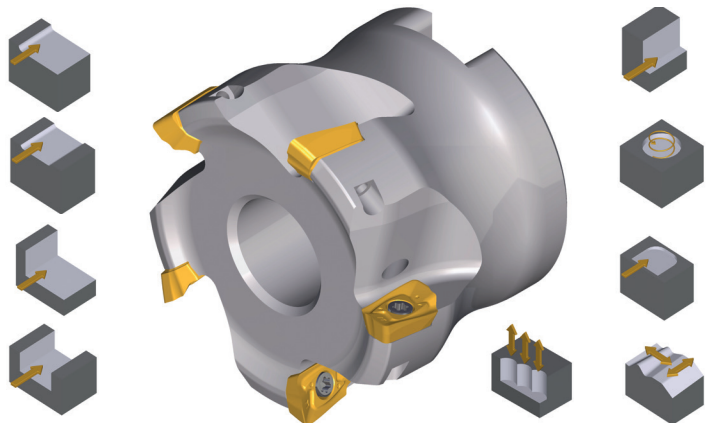
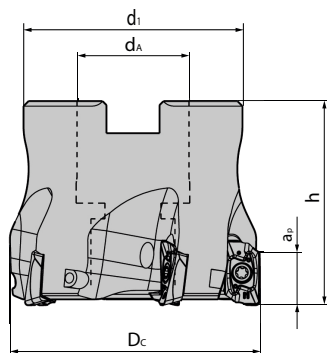
Face milling cutter 90° / LDMX 10 / inch



Dimensions in inch							Ordering code	Availability	Spare parts	
Dc	dA	d1	h	ap/90	ap/HFC	z [✱]				
1.5	0.75	1.375	1.5	0.354	0.055	4	BFU90 LD10.1500 Z04	●	 Fixation screw AP02-25068 5085706 MA= 2Nm	 Torque wrench IP8 5088519
2.0	0.75	1.75	1.5	0.354	0.055	5	BFU90 LD10.2000 Z05	●		
2.5	1.0	2.25	1.75	0.354	0.055	6	BFU90 LD10.2500 Z06	●		
3.0	1.0	2.25	2.0	0.354	0.055	8	BFU90 LD10.3000 Z08	●		

Order example: 10 pieces BEU90 LD10.1500 Z04

End milling cutter 90° / LDMX 10 / metric

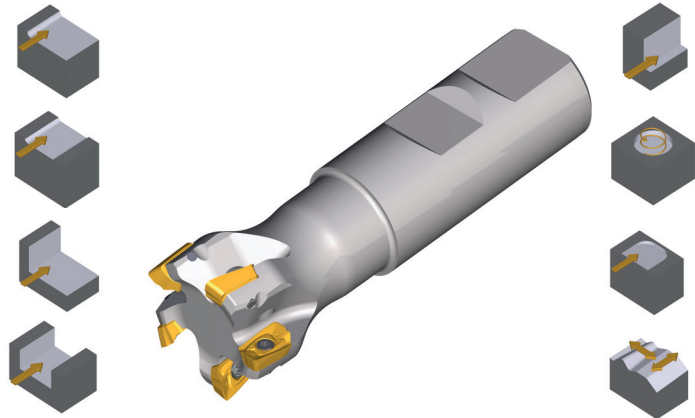
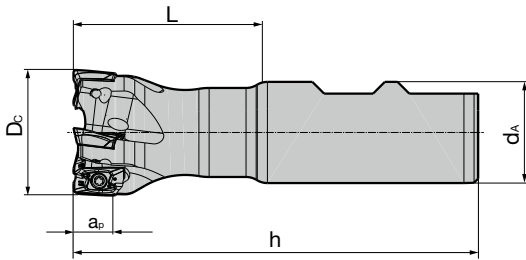

Dimensions in mm							Ordering code	Availability	Spare parts	
Dc	dA	L	h	ap/90	ap/HFC	z [✱]				
16	16	37	85	9	1.4	2	BE90 LD10.016 Z02	●	AP02-25051 5091691 M _A = 2Nm	
18	18	38	90	9	1.4	2	BE90 LD10.018 Z02	○		
20	20	40	90	9	1.4	2	BE90 LD10.020 Z02	●		
20	20	40	140	9	1.4	2	BE90 LD10.020 Z02 140	○	 Fixation screw AP02-25068 5085706 M _A = 2Nm	Torque wrench IP8 5088519
20	20	40	90	9	1.4	3	BE90 LD10.020 Z03	●		
20	20	40	175	9	1.4	3	BE90 LD10.020 Z03 175	○		
25	25	50	106	9	1.4	3	BE90 LD10.025 Z03	●		
25	25	50	106	9	1.4	4	BE90 LD10.025 Z04	●		
32	32	64	124	9	1.4	3	BE90 LD10.032 Z03	●		
32	32	64	124	9	1.4	5	BE90 LD10.032 Z05	●		

Order example: 10 pieces BE90 LD10.016 Z02

End milling cutter 90° / LDMX 10 / inch

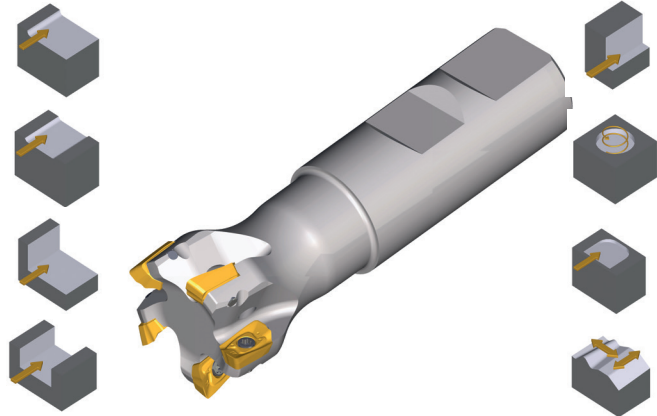
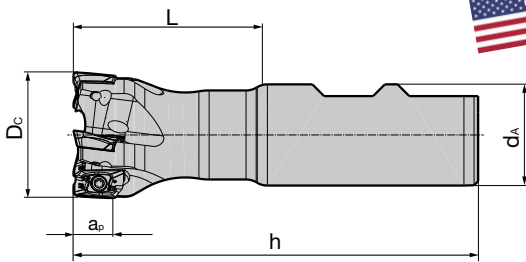

Dimensions in inch							Ordering code	Availability	Spare parts	
Dc	dA	L	h	ap/90	ap/HFC	z [✱]				
0.500	0.625	1.25	3.25	0.354	0.055	1	BEU90 LD10.0500 Z01 325	●	AP02-25051 5091691 M _A = 2Nm	
0.625	0.625	1.25	3.25	0.354	0.055	2	BEU90 LD10.0625 Z02 325	●		
0.750	0.750	1.625	3.5	0.354	0.055	2	BEU90 LD10.0750 Z02 350	●		
1.0	1.0	2.0	4.0	0.354	0.055	3	BEU90 LD10.1000 Z03 400	●	 Fixation screw AP02-25068 5085706 M _A = 2Nm	Torque wrench IP8 5088519
1.25	1.0	2.0	4.0	0.354	0.055	3	BEU90 LD10.1250 Z03 400	●		

Order example: 10 pieces BEU90 LD10.0500 Z01 325

Screw on type 90° / LDMX 10 / metric

Dimensions in mm								Ordering code	Availability	Spare parts	
Dc	dA	h	L	ap/90	ap/HFC	M	z				
16	13.8	49	29	9	1.4	M8	2	BS90 LD10.016 Z02 M08	●	AP02-25051 5091691 MA = 2Nm	
20	18	49	29	9	1.4	M10	3	BS90 LD10.020 Z03 M10	●		
25	21	54	32	9	1.4	M12	3	BS90 LD10.025 Z03 M12	●		
25	21	54	32	9	1.4	M12	4	BS90 LD10.025 Z04 M12	●		
32	29	66	43	9	1.4	M16	3	BS90 LD10.032 Z03 M16	●		Torque wrench IP8 5088519
32	29	66	43	9	1.4	M16	5	BS90 LD10.032 Z05 M16	●		
40	29	66	43	9	1.4	M16	6	BS90 LD10.040 Z06 M16	○		

Order example: 1 Piece BS90 LD10.016 Z02 M08



Insert Size 10							Cutting materials Ident No.											
N = Number of cutting edges	Ordering code	l	d	s	d ₁	r	BCP20M	BCP25M	BCP30M	BCP35M	BCP40M	BCM35M	BCM40M	BCK15M	BCK20M	BCN15M	BCS35M	
							90° inserts											
 N = 2	LDMX 100408 SR-MP	10	6.6	4.76	2.8	0.8	●			●								
	LDMX 100408 SR-MM	10	6.6	4.76	2.8	0.8						●	●					
	LDMX 100408 SR-MK	10	6.6	4.76	2.8	0.8									●			
	LDMX 100408 FR-MN	10	6.6	4.76	2.8	0.8										●		
	LDMX 100408 SR-MT	10	6.6	4.76	2.8	0.8											□	
	LDMX 100420 SR-MP	10	6.6	4.76	2.8	2.0		●		●								
	LDMX 100430 SR-MP	10	6.6	4.76	2.8	3.0		●		●								
HFC insert																		
 N = 2	LDMX 100415 SR-MPH	1.5	6.6	4.76	2.8	1.5	●	●	●	●								
	LDMX 100415 SR-MMH	1.5	6.6	4.76	2.8	1.5						●	●					
	LDMX 100415 SR-MKH	1.5	6.6	4.76	2.8	1.5								●	●			

Order example: 10 pieces LDMX 100408 SR-MP BCP35M

- Available from stock
- On request
- Available 4th quarter 2018

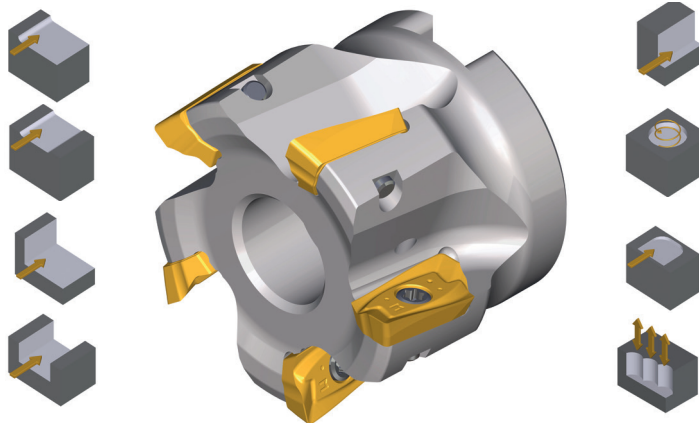
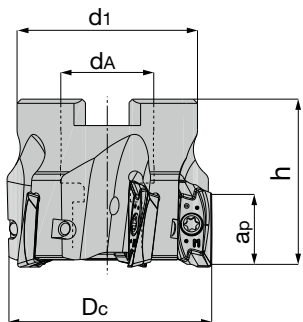
Face milling cutter 90° / LDMX 18 / metric





Dimensions in mm						Ordering code	Availability	Spare parts	
Dc	dA	d1	h	ap/90	z [☆]				
40	16	35	40	17	4	BF90 LD18.040 Z04	●	 Fixation screw AP02-35100 5092669 M _A = 3Nm	 Torque wrench IP15 5088520
50	22	43	40	17	5	BF90 LD18.050 Z05	●		
52	22	43	40	17	5	BF90 LD18.052 Z05	○		
63	22	48	40	17	5	BF90 LD18.063 Z05	●		
63	22	48	40	17	6	BF90 LD18.063 Z06	○		
66	22	48	40	17	6	BF90 LD18.066 Z06	○		
80	27	60	50	17	7	BF90 LD18.080 Z07	●		
100	32	78	50	17	8	BF90 LD18.100 Z08	●		
125	40	90	60	17	9	BF90 LD18.125 Z09	●		
160	40	115	60	17	10	BF90 LD18.160 Z10 NC	●		

Order example: 1 Piece BS90 LD18.040 Z04

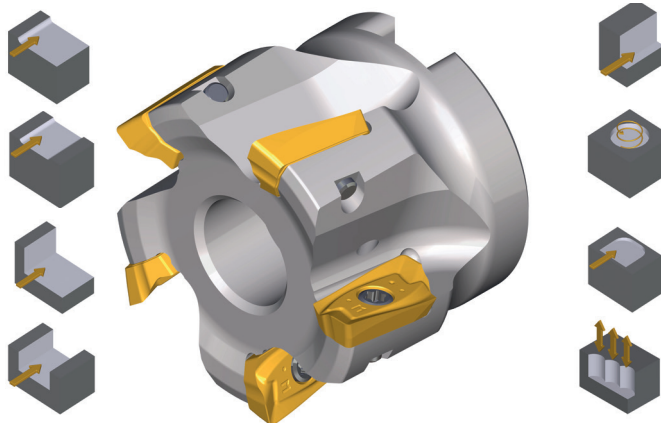
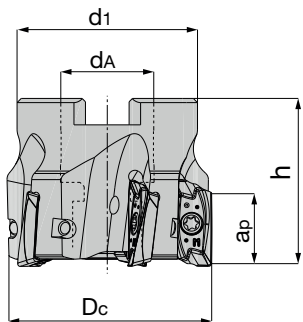
Face milling cutter 90° / LDMX 18 / inch





Dimensions in inch						Ordering code	Availability	Spare parts	
Dc	dA	d1	h	ap/90	z [☆]				
1.5	0.75	1.375	2	0.670	3	BFU90 LD18.1500 Z03	□	 Fixation screw AP02-35100 5092669 M _A = 3Nm	 Torque wrench IP15 5088520
2.0	0.75	1.75	1.5	0.670	4	BFU90 LD18.2000 Z04	□		
2.5	1.0	2.25	1.75	0.670	5	BFU90 LD18.2500 Z05	□		
3.0	1.0	2.25	1.75	0.670	7	BFU90 LD18.3000 Z07	□		
4.0	1.5	3.75	2.25	0.670	8	BFU90 LD18.4000 Z08	□		
5.0	1.5	3.75	2.5	0.670	9	BFU90 LD18.5000 Z09	□		

Order example: 1 Piece BFU90 LD18.1500 Z03



- Available from stock
- On request
- Available 4th quarter 2018

End milling cutter 90° / LDMX 18 / metric

Dimensions in mm						Ordering code	Availability	Spare parts		
Dc	dA	L	h	ap	z [✱]			 Fixation screw AP02-35100 5092669 M _A = 3Nm	 Torque wrench IP15 5088520	
25	25	50	106	17	2	BE90 LD18.025 Z02	●			
32	32	64	124	17	3	BE90 LD18.032 Z03	●			
40	32	65	130	17	4	BE90 LD18.040 Z04	●			

Order example: 1 piece BE90 LD18.025 Z02

End milling cutter 90° / LDMX 18 / inch

Dimensions in inch						Ordering code	Availability	Spare parts		
Dc	dA	L	h	ap	z [✱]			 Fixation screw AP02-35100 5092669 M _A = 3Nm	 Torque wrench IP15 5088520	
1.0	1.0	2.0	4.0	0.670	2	BEU90 LD18.1000 Z02	□			
1.25	1.0	2.25	4.0	0.670	3	BEU90 LD18.1250 Z03	□			
1.5	1.25	2.25	4.5	0.670	4	BEU90 LD18.1500 Z04	□			

Order example: 1 piece BEU90 LD18.1000 Z02

Cutting data recommendations page 82-83
 NC = no coolant

- Available from stock
- On request
- Available 4th quarter 2018

Insert Size 18							Cutting materials											
N = Number of cutting edges	Ordering code	l	d	s	d ₁	r	BCP20M	BCP25M	BCP30M	BCP35M	BCP40M	BCM35M	BCM40M	BCK15M	BCK20M	BCN10M	BWN10M	
							90° inserts											
	LDMX 180508 SR-MP	18	9.65	5	4.15	0.8		●		●	●							
	LDMX 180508 SR-MM	18	9.65	5	4.15	0.8						●	●					
	LDMX 180508 SR-MK	18	9.65	5	4.15	0.8									●			
	LDGX 180508 FR-MN	18	9.65	5	4.15	0.8											●	●
	LDMX 180512 SR-RP	18	9.65	5	4.15	1.2		●		●	●							
	LDMX 180512 SR-RK	18	9.65	5	4.15	1.2										●		

Order example: 10 pieces LDMX 180508 SR-MP BCP25M
 Description of grades page 114

● Available from stock
 ○ On request

DELTAtec 90P Feed

Multi Functional

www.boehlerit.com

Ø 40 mm - 200 mm Face Milling Cutter
Insert size 10, 14 and 18

Ø 1 1/2" - 5" Face Milling Cutter
Insert size 10 and 14

Ø 25 mm - 32 mm End Milling Cutter
Insert size 10

Ø 1" - 1 1/4" End Milling Cutter
Insert size 10

Ø 25 mm - 40 mm Screw on type 90°
Insert size 10

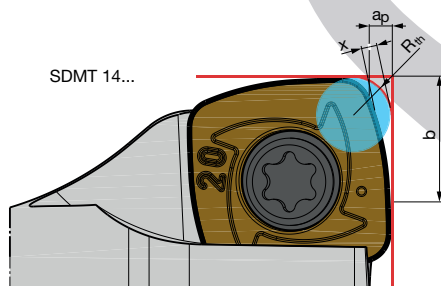

SDM..	R _{th}	a _p	x	b
10	2.25	1.1	0.62	8.033
14	3.45	2.2	0.93	10.868
18	4.82	3.5	1.24	13.77

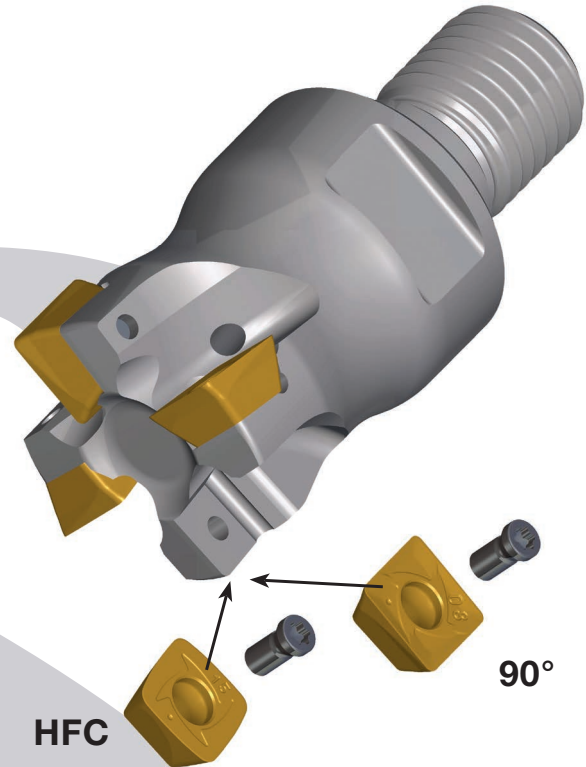

Special features: Milling HFC

- Multifunctional tool system for highest productivity
- 1 basic body for 2 machining operations = multifunctional
- Facilitation of storage and tool procurement through less articles
- 4 real usable cutting edges
- Smooth cut also on full groove due to perfect coordinated milling geometry
- Optimal consumption of the axial cutting forces due to special layout of the radii on the cutting edge
- Highest tooth feed (up to fz = 3.0 mm with SDMT 18)
- Screw on type milling cutter in combination with solid carbide extensions minimize vibrations on overhangs up to 300 mm

Special features: Milling 90°

- Exactly 90° on 4 cutting edges up to 1/2 cutting edge length on all diameter
- Smooth cut due to positive basic geometry
- Unequal division leads to reduction of vibration and extremely smooth running
- Maximum productivity increase due to high metal removal per cutting edge
- Process security due to non problematic wear behaviour and stabilisation of the cutting edge through special insert geometry

HFC Ramping angle



Diameter Milling cutter	Ramping angle HFC milling cutter α max. SDM 10....	Ramping angle HFC milling cutter α max. SDM 14....	Ramping angle HFC milling cutter α max. SDM 18....
Ø 25	4.4°	-	-
Ø 32	2.9°	-	-
Ø 40	2.0°	-	-
Ø 50	1.5°	2.4°	-
Ø 63	1.1°	1.7°	-
Ø 80	0.8°	1.3°	2.5°
Ø 100	0.7°	1.0°	2.0°
Ø 125	0.5°	0.7°	1.6°
Ø 160	-	-	1.3°
Ø 200	-	-	1.0°

90° Ramping angle



Diameter Milling cutter	Ramping angle 90° milling cutter α max. SDM 10....	Ramping angle 90° milling cutter α max. SDM 14....
Ø 25	7.0°	-
Ø 32	4.6°	-
Ø 40	3.3°	-
Ø 50	2.4°	5.5°
Ø 63	1.8°	3.7°
Ø 80	1.3°	2.6°
Ø 100	1.0°	1.9°
Ø 125	0.8°	1.5°
Ø 160	0.5°	-

HFC High Feed cutting parameter

SDM. 10..

Insert geometry	Cutting depth [mm] a_p max. SDM..10...	Feed [mm] f_z SDM..10...
MPH	0.5 0.8 1.3	0.6 1 1.4
MMH	0.5 0.8 1.3	0.5 0.9 1.4
RPH	0.5 1 1.5	0.7 1.1 1.6
RKH	0.5 1 1.5	0.7 1.2 1.6
MTH	0.5 0.7 1.2	0.5 0.7 1.2
RHH	0.4 0.8 1.2	0.4 1.1 1.6

SDM. 14..

Insert geometry	Cutting depth [mm] a_p max. SDM..14...	Feed [mm] f_z SDM..14...
MPH	0.6 1.2 2.2	0.7 1.4 2.2
MMH	0.6 1.2 2.2	0.8 1.2 2.2
RPH	0.7 1.5 2.4	0.8 1.6 2.4
RKH	0.70 1.6 2.4	0.8 1.7 2.4
MHH	0.4 1.2 2.2	0.4 1.2 2.2
RHH	0.5 1.5 2.4	0.5 1.6 2.4

SDM. 18..

Insert geometry	Cutting depth [mm] a_p max. SD..18	Feed [mm] f_z SD..18
MPH	1.0 2.2 3.2	1.2 1.8 2.8
MMH	1.0 2.0 3.0	1.0 1.6 2.5
RPH	1.0 2.5 3.5	1.4 2.2 3
RKH	1.0 2.8 3.5	1.4 2.5 3
RHH	1.0 2.2 3.5	0.8 1.8 2.8

90° Milling parameter

SDM. 10..



Insert geometry	Cutting depth [mm] a_p max. SDM..10...	Feed [mm] f_z SDM..10...
MP	0.8 3 9.0	0.10 0.18 0.23
MM	0.8 3 9.0	0.08 0.14 0.2
MK	0.8 3 9.0	0.10 0.2 0.26
MN	0.8 5 9.0	0.05 0.12 0.20

SDM. 14..

Insert geometry	Cutting depth [mm] a_p max. SDM..14...	Feed [mm] f_z SDM..14...
MP	1.2 6 12.5	0.1 0.2 0.25
MM	1.2 6 12.5	0.1 0.15 0.22
MK	1.2 6 12.5	0.1 0.22 0.28
MN	1.2 8 12.5	0.06 0.14 0.22

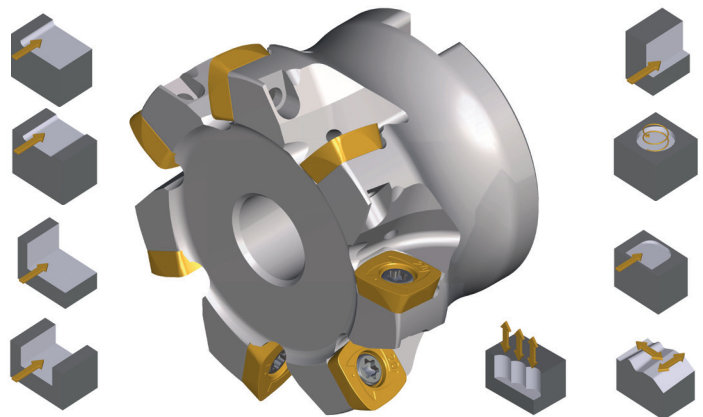
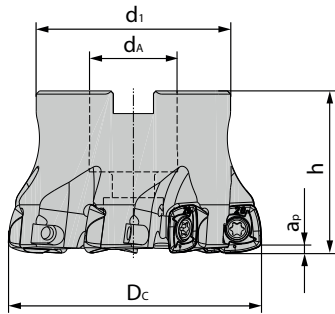
Face milling cutter 90° / SDM. 10.. / metric





Dimensions in mm							Ordering code	Availability	Spare parts	
Dc	dA	d1	h	ap/90	ap/HFC	z [±]				
40	16	35	40	9	1.5	4	BF90 SD10.040 Z04	●	 Fixation screw AP02-30083 5112357 $M_A = 2Nm$	 Torque wrench IP9 5118124
40	16	35	40	9	1.5	6	BF90 SD10.040 Z06	●		
42	16	35	40	9	1.5	5	BF90 SD10.042 Z05	●		
50	22	43	40	9	1.5	5	BF90 SD10.050 Z05	●		
50	22	43	40	9	1.5	7	BF90 SD10.050 Z07	●		
52	22	43	40	9	1.5	5	BF90 SD10.052 Z05	●		
63	22	48	40	9	1.5	6	BF90 SD10.063 Z06	●		
63	22	48	40	9	1.5	8	BF90 SD10.063 Z08	●		
66	22	48	40	9	1.5	5	BF90 SD10.066 Z05	○		
80	27	60	50	9	1.5	8	BF90 SD10.080 Z08	●		

Order example: 1 Piece BF90 SD10.040 Z04

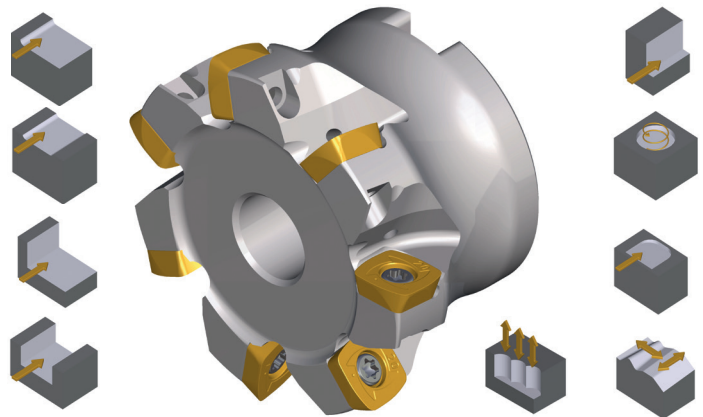
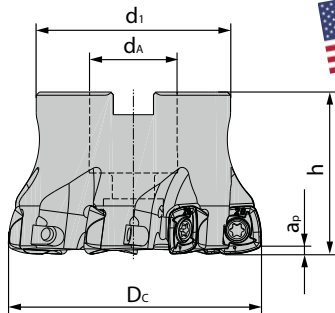
Face milling cutter 90° / SDM. 10.. / inch



Dimensions in inch							Ordering code	Availability	Spare parts	
Dc	dA	d1	h	ap/90	ap/HFC	z [±]				
1.5	0.75	1.375	1.5	0.354	0.059	5	BFU90 SD10.1500 Z05	●	 Fixation screw AP02-30083 5112357 $M_A = 2Nm$	 Torque wrench IP9 5118124
2.0	0.75	1.75	1.5	0.354	0.059	5	BFU90 SD10.2000 Z05	●		
2.0	0.75	1.75	1.5	0.354	0.059	7	BFU90 SD10.2000 Z07	●		
2.5	1.0	2.25	1.75	0.354	0.059	6	BFU90 SD10.2500 Z06	●		
2.5	1.0	2.25	1.75	0.354	0.059	8	BFU90 SD10.2500 Z08	●		

Order example: 1 piece BFU90 SD10.1500 Z04

End milling cutter 90° / SDM. 10.. / metric

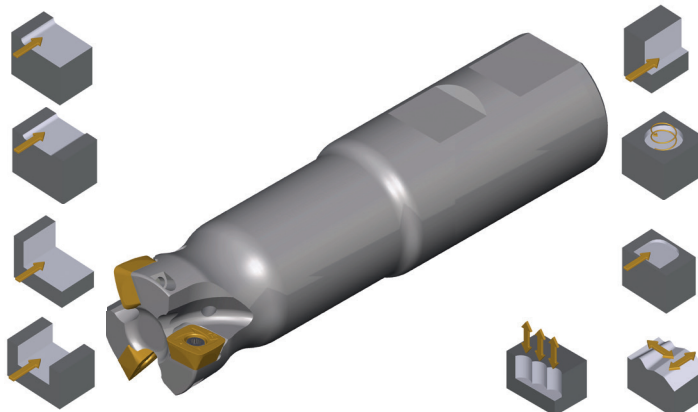
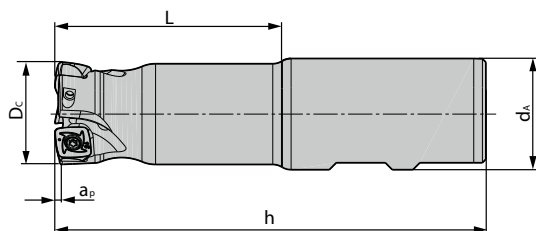

Dimensions in mm							Ordering code	Availability	Spare parts	
Dc	dA	L	h	ap/90	ap/HFC	z [☆]				
25	25	50	106	9	1.5	2	BE90 SD10.025 Z02	●	 Fixation screw AP02-30083 5112357 MA = 2Nm	 Torque wrench IP9 5118124
25	25	50	106	9	1.5	3	BE90 SD10.025 Z03	●		
32	32	64	124	9	1.5	3	BE90 SD10.032 Z03	●		

Order example: 1 Piece BE90 SD10.025 Z02

End milling cutter 90° / SDM. 10.. / inch

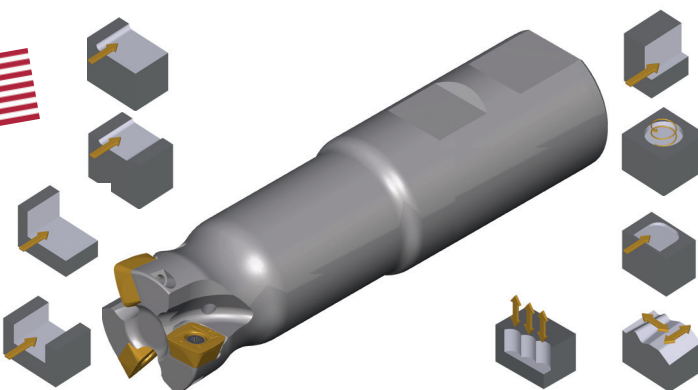
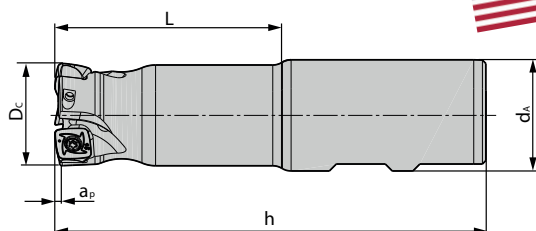

Dimensions in inch							Ordering code	Availability	Spare parts	
Dc	dA	L	h	ap/90	ap/HFC	z [☆]				
1.0	1.0	2.0	4.0	0.354	0.059	2	BEU90 SD10.1000 Z02	●	 Fixation screw AP02-30083 5112357 MA = 2Nm	 Torque wrench IP9 5118124
1.0	1.0	2.0	4.0	0.354	0.059	3	BEU90 SD10.1000 Z03	●		
1.25	1.25	2.5	5.0	0.354	0.059	3	BEU90 SD10.1250 Z03	●		
1.25	1.25	2.5	5.0	0.354	0.059	4	BEU90 SD10.1250 Z04	●		

Order example: 1 piece BEU90 SD10.1000 Z02

Screw on type 90° / SDM. 10.. / metric

Dimensions in mm								Ordering code	Availability	Spare parts	
Dc	d1	L	h	ap/90	ap/HFC	M	z				
25	24	32	54	9	1.5	M12	2	BS90 SD10.025 Z02 M12	●	Fixation screw AP02-30083 5112357 MA = 2Nm	Torque wrench IP9 5118124
25	24	32	54	9	1.5	M12	3	BS90 SD10.025 Z03 M12	●		
32	29	42	66	9	1.5	M16	3	BS90 SD10.032 Z03 M16	●		
32	29	42	66	9	1.5	M16	4	BS90 SD10.032 Z04 M16	●		
40	29	42	66	9	1.5	M16	4	BS90 SD10.040 Z04 M16	●		

Order example: 1 piece BS90 SD10.025 Z02 M12

Insert Size 10							Cutting materials Ident No.														
N = Number of cutting edges	Ordering code	l	d	s	d ₁	r	BCP20M	BCP25M	BCP30M	BCP35M	BCP40M	BCM35M	BCM40M	BCK15M	BCK20M	BCN15M	BCS35M	BCH05M	BCH10M	BCH30M	
							90° inserts														
 N = 4	SDMT 100408 SR-MP	10.4	10.4	4.86	3.5	0.8	●	●	●												
	SDMT 100408 ER-MM	10.4	10.4	4.86	3.5	0.8					●	●									
	SDMT 100408 SR-MK	10.4	10.4	4.86	3.5	0.8								●							
	SDMT 100408 FR-MN	10.4	10.4	4.86	3.5	0.8									●						
HFC inserts																					
 N = 4	SDMT 100415 SR-MPH	1.1	10.2	4.76	3.5	1.5	●	●	●	●											
	SDMT 100415 SR-MHH	1.1	10.2	4.76	3.5	1.5														●	
	SDMT 100415 ER-MMH	1.1	10.2	4.76	3.5	1.5						●	●								
	SDGT 100415 SR-MTH	1.1	10.2	4.76	3.5	1.5												□			
HFC inserts																					
 N = 4	SDMW 100415 SR-RPH	1.1	10.2	4.76	3.5	1.5	●	●	●	●											
	SDMW 100415 SR-RKH	1.1	10.2	4.76	3.5	1.5								●	●						
	SDMW 100415 SR-RHH	1.1	10.2	4.76	3.5	1.5													●	●	●

Order example: 10 pieces SDMT 100408 SR-MP BCP35M

- Available from stock
- On request
- Available 4th quarter 2018

Face milling cutter 90°/ SDM.. 14.. / metric

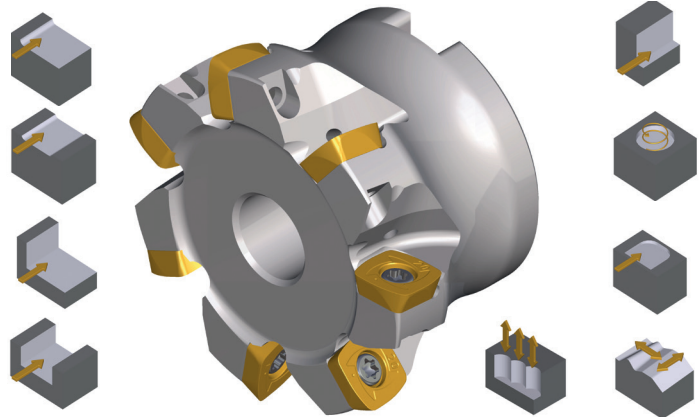
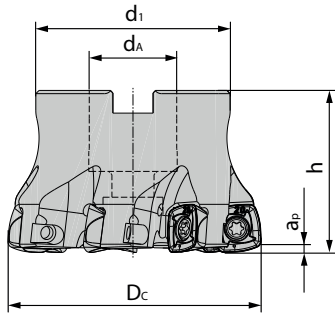

Dimensions in mm							Ordering code	Availability	Spare parts	
Dc	dA	d1	h	ap/90	ap/HFC	z ^z				
50	22	43	40	12	2.5	4	BF90 SD14.050 Z04	○	 Fixation screw AP02-50108 MA= 5 Nm	 Torque wrench IP20 5088521
50	22	43	40	12	2.5	5	BF90 SD14.050 Z05	●		
52	22	43	40	12	2.5	4	BF90 SD14.052 Z04	○		
52	22	43	40	12	2.5	5	BF90 SD14.052 Z05	●		
63	22	48	40	12	2.5	6	BF90 SD14.063 Z06	●		
66	22	48	40	12	2.5	6	BF90 SD14.066 Z06	●		
80	27	60	50	12	2.5	7	BF90 SD14.080 Z07	●		
100	32	78	50	12	2.5	7	BF90 SD14.100 Z07	●		
100	32	78	50	12	2.5	9	BF90 SD14.100 Z09	●		
125	40	90	60	12	2.5	11	BF90 SD14.125 Z11	●		
160	40	90	60	12	2.5	10	BF90 SD14.160 Z10	○		

Order example: 1 piece BF90 SD14.050 Z04

Face milling cutter 90°/ SDM.. 14.. / inch

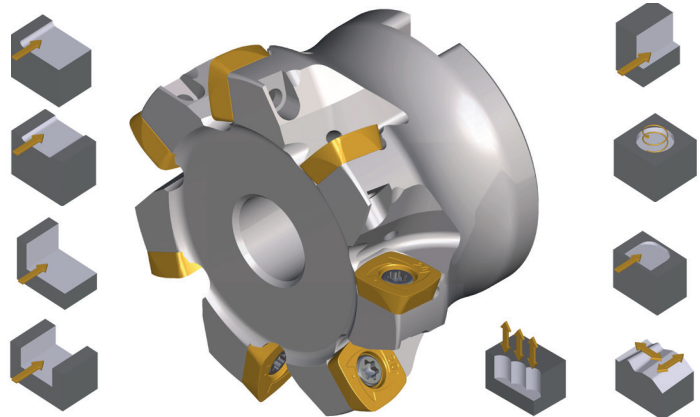
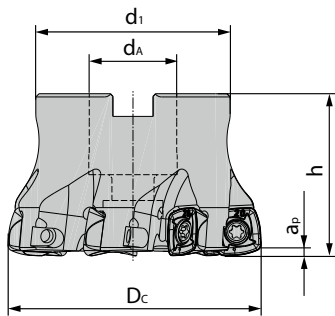

Dimensions in inch							Ordering code	Availability	Spare parts	
Dc	dA	d1	h	ap/90	ap/HFC	z ^z				
2.0	0.75	1.75	1.5	0.492	0.137	4	BFU90 SD14.2000 Z04	●	 Fixation screw AP02-50108 MA= 5 Nm	 Torque wrench IP20 5088521
2.0	0.75	1.75	1.5	0.492	0.137	5	BFU90 SD14.2000 Z05	●		
2.5	1.0	2.25	1.75	0.492	0.137	6	BFU90 SD14.2500 Z06	●		
3.0	1.0	2.25	2.0	0.492	0.137	5	BFU90 SD14.3000 Z05	●		
3.0	1.0	2.25	2.0	0.492	0.137	7	BFU90 SD14.3000 Z07	●		
4.0	1.5	3.75	2.25	0.492	0.137	7	BFU90 SD14.4000 Z07	●		
4.0	1.5	3.75	2.25	0.492	0.137	9	BFU90 SD14.4000 Z09	●		
5.0	1.5	3.75	2.5	0.492	0.137	9	BFU90 SD14.5000 Z09	●		

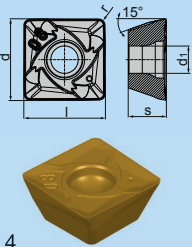
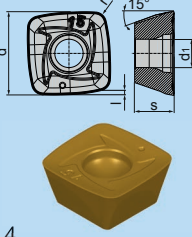

Order example: 1 piece BFU90 SD14.2000 Z04

Insert Size 14							Cutting materials Ident No.																	
N = Number of cutting edges	Ordering code	l	d	s	d ₁	r	BCP20M	BCP25M	BCP30M	BCP35M	BCP40M	BCM35M	BCM40M	BCK15M	BCK20M	BCN15M	BCH05M	BCH10M	BCH30M					
							90° inserts  N = 4																	
	SDMT 140512 SR-MP	14.8	14.8	5.2	5.5	1.2		●		●	●													
	SDMT 140512 ER-MM	14.8	14.8	5.2	5.5	1.2						●	●											
	SDMT 140512 SR-MK	14.8	14.8	5.2	5.5	1.2									●									
	SDMT 140512 FR-MN	14.8	14.8	5.2	3.5	1.2										●								
HFC inserts  N = 4																								
	SDMT 140520 SR-MPH	2.2	14.7	5	5.5	2	●	●	●	●														
	SDMT 140520 SR-MHH	2.2	14.7	5	5.5	2													●					
	SDMT 140520 ER-MMH	2.2	14.7	5	5.5	2						●	●											
	SDMW 140520 SR-RPH	2.2	14.7	5	5.5	2	●	●	●	●														
	SDMW 140520 SR-RKH	2.2	14.7	5	5.5	2								●	●									
	SDMW 140520 SR-RHH	2.2	14.7	5	5.5	2												●	●	●				

Order example: 10 pieces SDMT 140512 SR-MP BCP35M

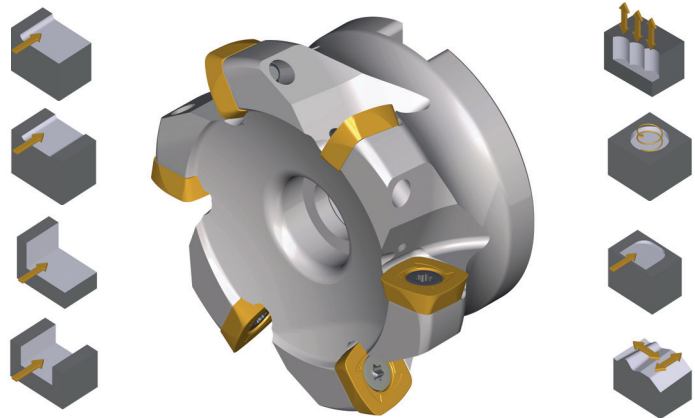
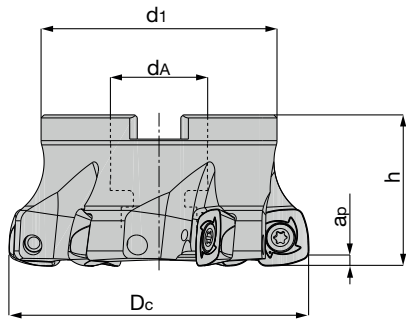
Face milling cutter 90°/ SDM.. 18.. / metric



Dimensions in mm						Ordering code	Availability	Spare parts	
Dc	dA	d1	h	ap/HFC	z				
80	27	60	50	3.5	5	BF90 SD18.080 Z05	●	 Fixation screw A02-60160 6401270 $M_A = 6Nm$	 Torque wrench T25 5088518
100	32	78	50	3.5	6	BF90 SD18.100 Z06	●		
125	40	90	60	3.5	7	BF90 SD18.125 Z07	●		
160	40	115	60	3.5	9	BF90 SD18.160 Z09	●		
200	60	140	65	3.5	11	BF90 SD18.200 Z11	●		

Order example: 1 piece BF90 SD18.080 Z05

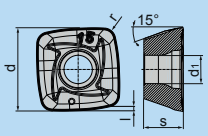
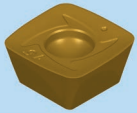
Insert Size 18							Cutting materials Ident No.													
N = Number of cutting edges	Ordering code	l	d	s	d ₁	r	BCP20M	BCP25M	BCP30M	BCP35M	BCP40M	BCM35M	BCM40M	BCK15M	BCK20M	BCN15M	BCH05M	BCH10M	BCH30M	
							 HFC inserts SDMT 180630 SR-MPH SDMT 180630 SR-MMH  N = 4							●	●				●	●
	SDMW 180630 SR-RPH	3	18.7	6	6.5	3.0				●	●									
	SDMW 180630 SR-RKH	3	18.7	6	6.5	3.0								●	●					
	SDMW 180630 SR-RHH	3	18.7	6	6.5	3.0														●

Order example: 10 pieces SDMT 180630 SR-MPH BCP25M

Ø 40 mm - 160 mm Face Milling Cutter
Insert size 10 and 15

Ø 20 mm - 40 mm End Milling Cutter
Insert size 10 und 15

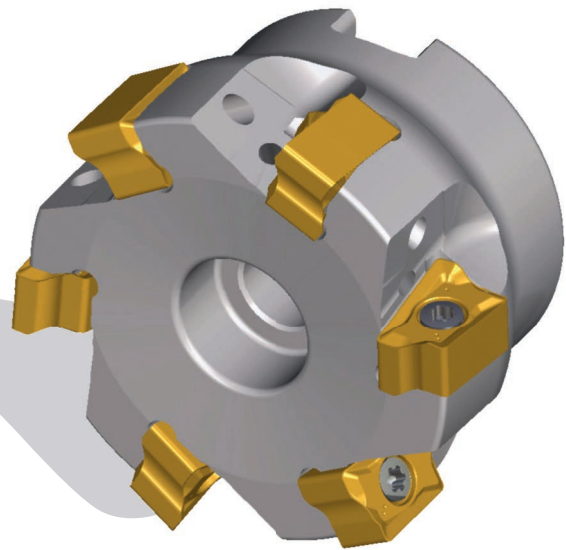

Special features: Milling 90°

- Stable tool system through negative geometry basic design
- Effective positive chip angle for smooth cut
- Productivity guaranteed through 4 cutting edges
- Available in 2 insert sizes
- End milling cutter in excess length available
- Article with status "On request" are deliverable in five working days

LNMX 10..



Insert geometry	Cutting depth [mm]	Feed [mm]
	a_p max LNMX 10...	f_z LNMX 10...
RP	1 4 9	0.15 0.25 0.35
RK	1 4 9	0.15 0.2 0.30
RM	1 4 9	0.15 0.2 0.30

LNMX 15..

Insert geometry	Cutting depth [mm]	Feed [mm]
	a_p max LNMX 15...	f_z LNMX 15...
RP	1 6.5 14	0.15 0.25 0.35
RK	1 6.5 14	0.15 0.25 0.35
RM	1 6.5 12	0.15 0.20 0.3

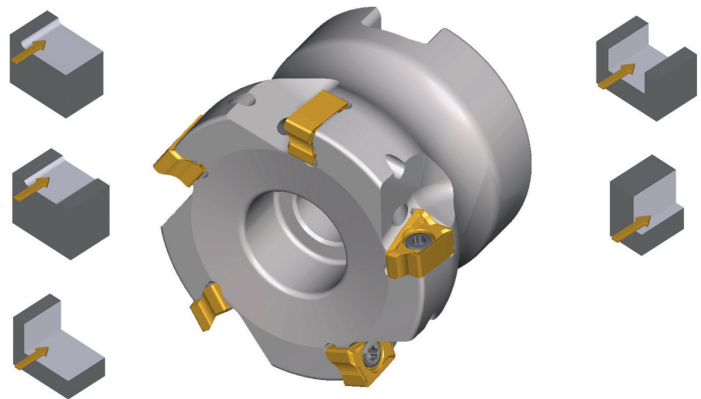
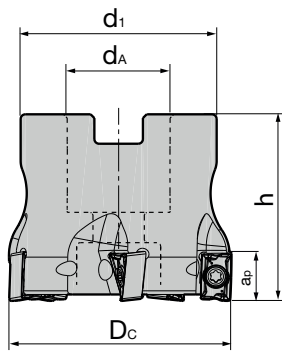
Face milling cutter 90° / LNMX 10.. / metric





Dimensions in mm						Ordering code	Availability	Spare parts	
Dc	dA	d1	ap	h	z [✱]				
40	16	35	9	40	4	BF90 LN10.040 Z04	●	 Fixation screw A02-30076 5084082 M _A = 2Nm	 Torque wrench T9 5088515
40	16	35	9	40	5	BF90 LN10.040 Z05	●		
50	22	42	9	40	5	BF90 LN10.050 Z05	●		
50	22	42	9	40	7	BF90 LN10.050 Z07	●		
63	22	49	9	40	6	BF90 LN10.063 Z06	●		
63	22	49	9	40	8	BF90 LN10.063 Z08	●		

Order example: 1 piece BF90 LN10.040 Z04

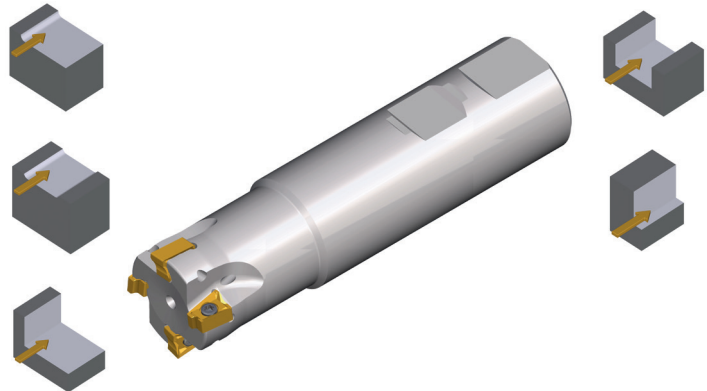
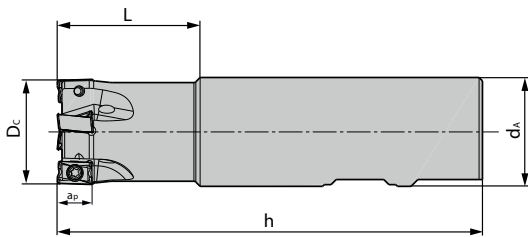
End milling cutter 90° / LNMX 10.. / metric



Dimensions in mm						Ordering code	Availability	Spare parts	
Dc	dA	h	ap	L	z [✱]				
20	20	100	9	30	2	BE90 LN10.020 Z02	●	 Fixation screw A02-30076 5084082 M _A = 2Nm	 Torque wrench T9 5088515
20	20	150	9	30	2	BE90 LN10.020 Z02 150	●		
20	20	100	9	30	3	BE90 LN10.020 Z03	●		
25	25	115	9	35	2	BE90 LN10.025 Z02	●		
25	25	150	9	35	2	BE90 LN10.025 Z02 150	●		
25	25	115	9	35	3	BE90 LN10.025 Z03	●		
32	32	125	9	42	3	BE90 LN10.032 Z03	●		
32	32	180	9	42	3	BE90 LN10.032 Z03 180	●		
32	32	125	9	42	4	BE90 LN10.032 Z04	●		
40	32	130	9	42	4	BE90 LN10.040 Z04	●		
40	32	130	9	42	5	BE90 LN10.040 Z05	●		

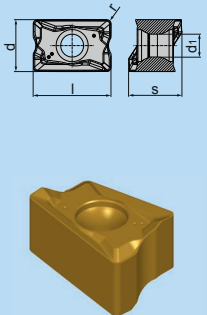

Order example: 1 piece BE90 LN10.020 Z02

Insert Size 10							Cutting materials Ident No.										
N = Number of cutting edges	Ordering code	l	d	s	d ₁	r	BCP20M	BCP25M	BCP30M	BCP35M	BCP40M	BCM35M	BCM40M	BCK15M	BCK20M	BCN10M	BWN10M
								LNMX 100605 SR-RP	10	6.6	6.35	2.8	0.5	●			●
	LNMX 100605 SR-RK	10	6.6	6.35	2.8	0.5								●	●		
	LNMX 100605 SR-RM	10	6.6	6.35	2.8	0.5						●					

Order example: 10 pieces LNMX 100605 SR-RP BCP25M
Description of grades page 114

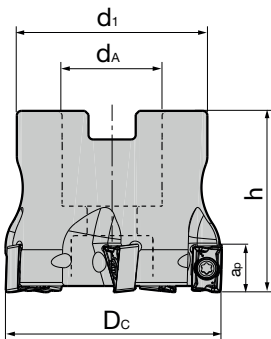

Face milling cutter 90°/ LNMX 15.. / metric

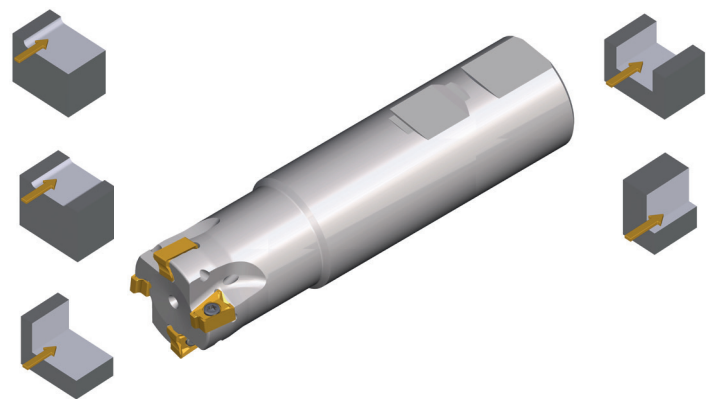
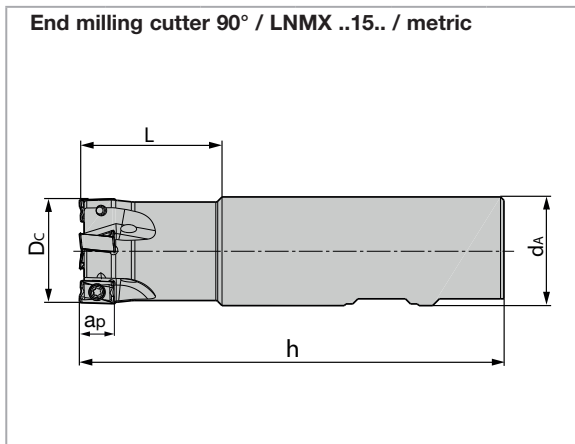

Dimensions in mm						Ordering code	Availability	Spare parts		
Dc	da	d1	ap	h	z [☆]			 Fixation screw AP13-40110 5084084 M _A = 3Nm	 Torque wrench IP15 5088520	
50	22	42	14	40	3	BF90 LN15.050 Z03	●			
50	22	42	14	40	4	BF90 LN15.050 Z04	●			
63	22	49	14	40	4	BF90 LN15.063 Z04	●			
63	22	49	14	40	6	BF90 LN15.063 Z06	●			
80	27	60	14	50	5	BF90 LN15.080 Z05	●			
80	27	60	14	50	7	BF90 LN15.080 Z07	●			
100	32	60	14	50	8	BF90 LN15.100 Z08	●			
125	40	90	14	63	10	BF90 LN15.125 Z10	●			
160	40	115	14	63	11	BF90 LN15.160 Z11	●			

Order example: 1 piece BF90 LN15.050 Z03



Dimensions in mm						Ordering code	Availability	Spare parts	
Dc	dA	h	ap	L	z [☆]				
32	32	125	14	40	3	BE90 LN15.032 Z03	●	 Fixation screw AP13-40110 5084084 M _A = 3Nm	 Torque wrench IP15 5088520
40	32	130	14	40	3	BE90 LN15.040 Z03	●		
40	32	130	14	40	4	BE90 LN15.040 Z04	●		

Order example: 1 Piece BE90 LN15.032 Z03

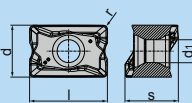
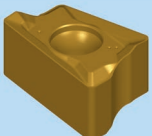
Insert Size 15							Cutting materials Ident No.										
N = Number of cutting edges	Ordering code	l	d	s	d ₁	r	BCP20M	BCP25M	BCP30M	BCP35M	BCP40M	BCM35M	BCM40M	BCK15M	BCK20M	BCN10M	BWN10M
							  N = 4	LNMX 151008 SR-RP	15	9.52	10.0	4.5	0.8	●	○	○	○
LNMX 151008 SR-RK	15	9.52	10.0	4.5	0.8	○		○	○	○	○	○	○	○	○	○	○
LNMX 151008 SR-RM	15	9.52	10.0	4.5	0.8	○		○	○	○	○	○	○	○	○	○	○

Order example: 10 pieces LNMX 151008 SR-RP BCP25M

Ø 50 mm - 315 mm
Face Milling Cutter
Insert size 13

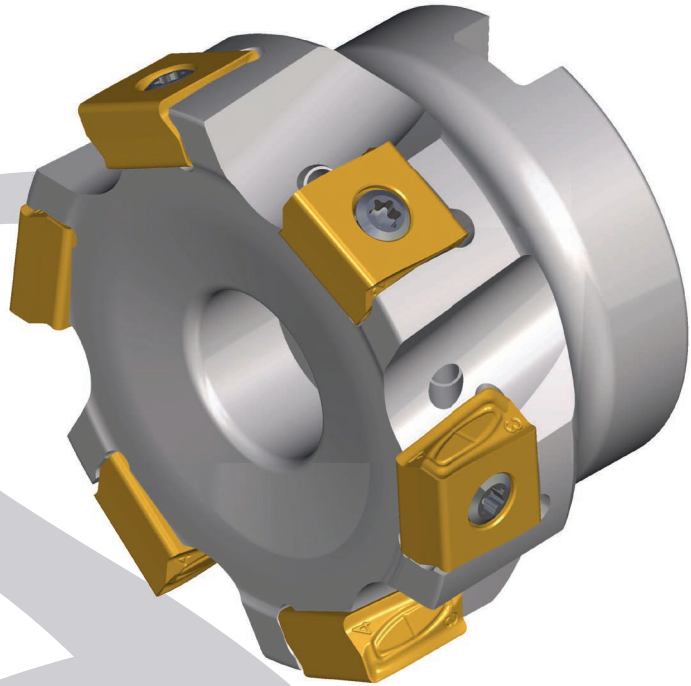

Special features: Milling 90°

- Due to tangential clamping of the inserts a very stable tool system result
- Productivity guaranteed through 4 cutting edges
- High machining security through thick tangential milling insert
- Smooth cut through helix geometry on the cutting edges

LNMX 13..

Insert geometry	Cutting depth [mm] a_p max	Feed [mm] f_z
RP	1 6.5 12	0.2 0.3 0.45
RK	1 6.5 12	0.25 0.35 0.55
MP	1 6.5 12	0.15 0.22 0.35
MM	1 6.5 12	0.15 0.22 0.35

Face milling cutter 45° for LNMX 13.. / metric

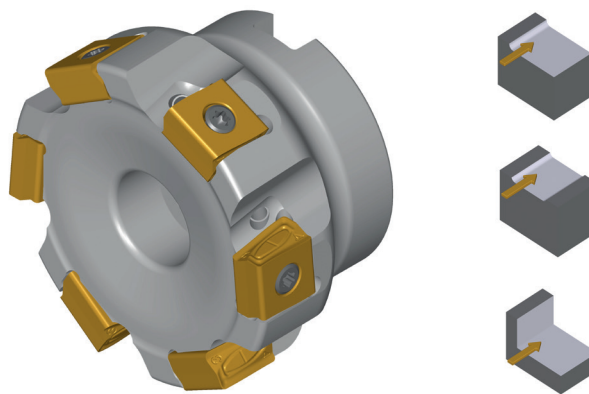
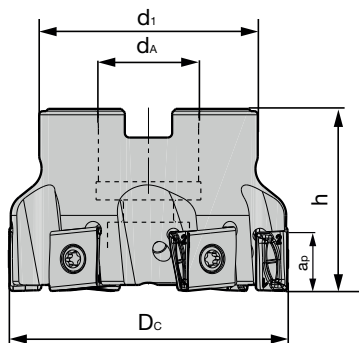

Dimensions in mm						Ordering code	Availability	Spare parts	
Dc	dA	d1	h	ap	z [☆]				
50	22	40	40	12	4	BF90 LN13.050 Z04	●	 Fixation screw AP02-40054 5085714 M _A = 3Nm	 Torque wrench IP15 5088520
50	22	40	40	12	5	BF90 LN13.050 Z05	○		
63	22	48	40	12	4	BF90 LN13.063 Z04	●		
63	22	48	40	12	6	BF90 LN13.063 Z06	●		
63	22	48	40	12	8	BF90 LN13.063 Z08	●		
80	27	48	40	12	5	BF90 LN13.080 Z05	○		
80	27	58	50	12	7	BF90 LN13.080 Z07	●		
80	27	58	50	12	10	BF90 LN13.080 Z10	○		
100	32	78	50	12	8	BF90 LN13.100 Z08	●		
100	32	78	50	12	13	BF90 LN13.100 Z13	○		
125	40	90	63	12	9	BF90 LN13.125 Z09	●		
125	40	90	63	12	9	BF90 LN13.125 Z11	○		
160	40	90	75	12	10	BF90 LN13.160 Z10 NC	●		
200	60	140	75	12	14	BF90 LN13.200 Z14 NC	○		
250	60	190	75	12	16	BF90 LN13.250 Z16 NC	○		
315	60	255	75	12	18	BF90 LN13.315 Z18 NC	○		

Order example: 1 Piece BF90 LN13.050 Z04

Insert Size 13							Cutting materials Ident No.										
N = Number of cutting edges	Ordering code	l	d	s	d ₁	r	BCP20M	BCP25M	BCP30M	BCP35M	BCP40M	BCM35M	BCM40M	BCK15M	BCK20M	BCN10M	BWN10M
							 N = 4	LNMX 131308 SR-RP	13	7	13	4.6	0.8			●	●
	LNMX 131308 SR-RK	13	7	13	4.6	0.8								●	●		
	LNMX 131308 SR-MP	13	7	13	4.6	0.8	●		●								
	LNMX 131308 SR-MM	13	7	13	4.6	0.8						●					

Order example: 10 pieces LNMX 131308 SR-RP BCP30M

Description of grades page 114
 NC = no coolant

● Available from stock
 ○ On request

Ø 40 mm - 125 mm Face Milling Cutter
Insert size 10 and 16

Ø 1 1/2" - 5" Face Milling Cutter
Insert size 10 and 16

Ø 12 mm - 40 mm End Milling Cutter
Insert size 10 and 16

Ø 1/2" - 1 1/2" End Milling Cutter
Insert size 10 and 16

Ø 16 mm - 32 mm Screw on type
Insert size 10

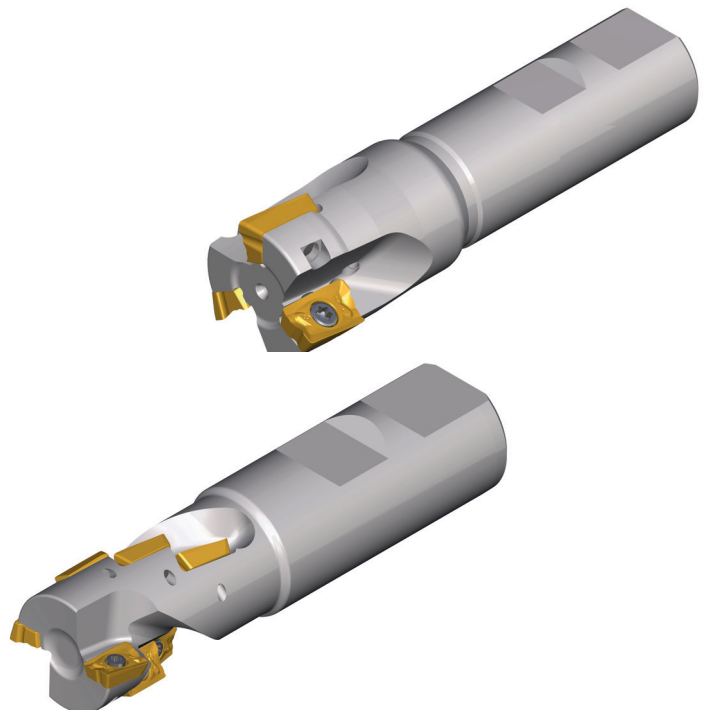
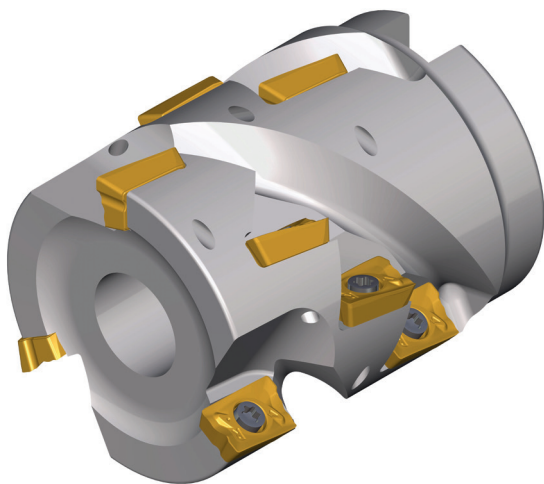
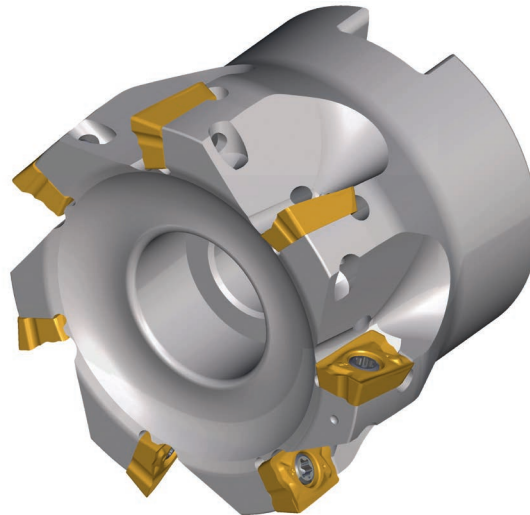

Special features:

- Hybrid geometry
- ISO insert with helix cutting edge and accurate cutting
- Varied geometry offer
- Varied grade offer
- Best cutting results only in combination with Boehlerit inserts + Boehlerit tools achievable
- BP and BM geometry only applicable in roughing version
- Screw on type tools in combination with vibration damping solid carbide extensions
- Special geometry for medium machining MP2 and for roughing RP2 of steel

Ramping angle



Diameter Milling cutter	Ramping angle Milling cutter α max. APT 10....	Ramping angle Milling cutter α max. APT 16....
Ø 16	4.5°	-
Ø 20	3.8°	-
Ø 25	2.5°	5.2°
Ø 32	1.7°	3.4°
Ø 40	1.3°	2.5°
Ø 50	0.9°	1.8°
Ø 63	0.7°	1.3°
Ø 80	0.5°	1.0°
Ø 100	-	0.7°
Ø 125	-	0.6°

90° Milling parameter

APT 10..

Insert geometry	Cutting depth [mm] a_p max APKT 10...	Feed [mm] f_z APKT 10...
MP2	0.5 3 9	0.1 0.15 0.2
MM2	0.5 3 9	0.1 0.15 0.2
RP2	0.5 3 9	0.2 0.22 0.28
RK2	0.5 3 9	0.2 0.25 0.3
MN2	0.5 5 9	0.1 0.16 0.24

APT 16..

Insert geometry	Cutting depth [mm] a_p max APKT 16...	Feed [mm] f_z APKT 16...
MP2	1 8 15	0.1 0.15 0.2
MM2	1 8 15	0.1 0.15 0.2
RP2	1 8 15	0.2 0.25 0.3
RK2	1 8 15	0.2 0.27 0.35
MN2	1 9 15	0.1 0.16 0.26

Helical cutter

APT 10..



Insert geometry	Cutting width [D x %] a_e max APKT 10...	Feed [mm] f_z APKT 10...
MP2	5 - 70%	0.1 0.15 0.2
MM2	5 - 70%	0.1 0.15 0.2
RP2	5 - 70%	0.2 0.22 0.28
RK2	5 - 70%	0.2 0.25 0.3
MN2	5 - 80%	0.1 0.16 0.24

APT 16..

Insert geometry	Cutting width [D x %] a_e max APKT 16...	Feed [mm] f_z APKT 16...
MP2	5 - 70%	0.1 0.15 0.2
MM2	5 - 70%	0.1 0.15 0.2
RP2	5 - 70%	0.2 0.25 0.3
RK2	5 - 70%	0.2 0.27 0.35
MN2	5 - 80%	0.1 0.16 0.26

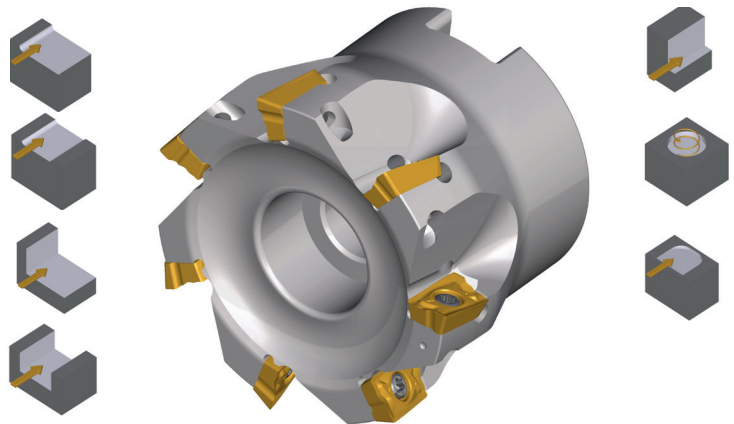
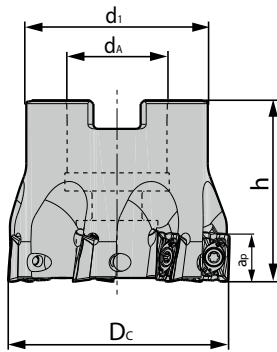
Face milling cutter 90°/ AP.T 10.. / metric





Dimensions in mm						Ordering code	Availability	Spare parts	
Dc	dA	d1	ap	h	z [☆]			 Fixation screw AP17-25055 5085710 MA = 2Nm	 Torque wrench IP8 5088519
40	16	32	9	40	6	BF90 AP10.040 Z06	●		
50	22	40	9	40	6	BF90 AP10.050 Z06	●		
50	22	40	9	40	7	BF90 AP10.050 Z07	●		
63	22	46	9	40	8	BF90 AP10.063 Z08	●		
80	27	54	9	50	10	BF90 AP10.080 Z10	●		

Order example: 1 piece BF90 AP10.040 Z06

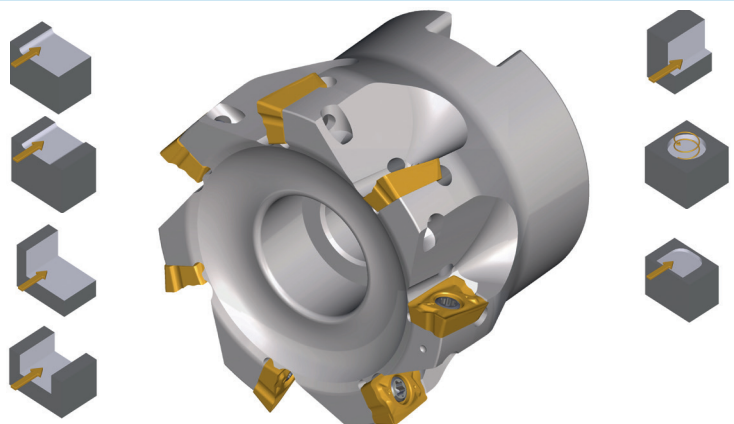
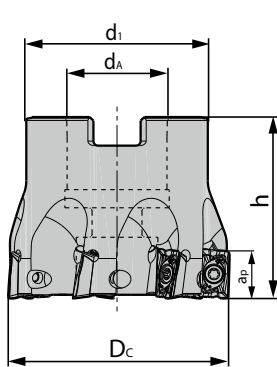
Face milling cutter 90°/ AP.T 10.. / inch





Dimensions in inch						Ordering code	Availability	Spare parts	
Dc	dA	d1	ap	h	z [☆]			 Fixation screw AP17-25055 5085710 MA = 2Nm	 Torque wrench IP8 5088519
1.5	0.75	1.375	0.354	1.5	6	BFU90 AP10.1500 Z06	●		
2.0	0.75	1.75	0.354	1.5	6	BFU90 AP10.2000 Z06	●		
2.0	0.75	1.75	0.354	1.5	7	BFU90 AP10.2000 Z07	●		
2.5	1.0	2.25	0.354	1.75	8	BFU90 AP10.2500 Z08	●		
3.0	1.0	2.25	0.354	1.75	10	BFU90 AP10.3000 Z10	●		

Order example: 1 piece BFU90 AP10.1500 Z06

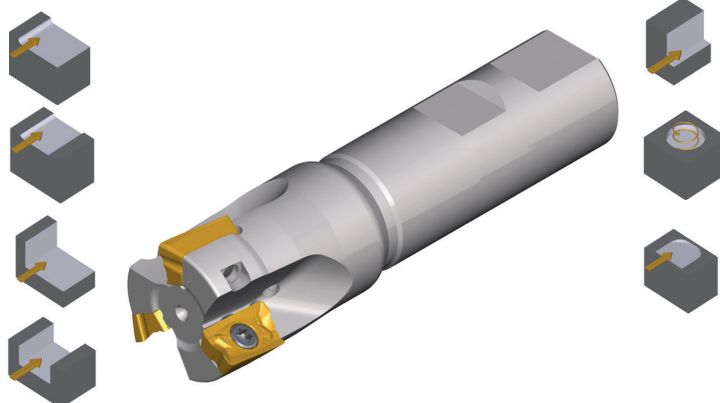
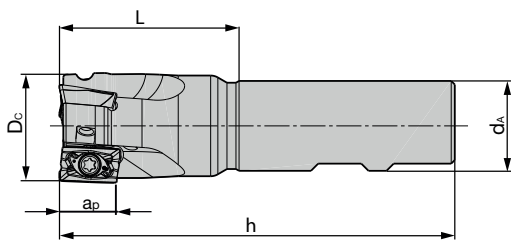
End milling cutter 90° / AP.T 10.. / metric





Dimensions in mm						Ordering code	Availability	Spare parts	
Dc	dA	h	ap	L	z [✱]				
12	16	80	9	32	1	BE90 AP10.012 Z01	●	 Fixation screw AP17-25055 5085710 M _A = 2Nm	 Torque wrench IP8 5088519
12	16	120	9	32	1	BE90 AP10.012 Z01 120	○		
16	16	85	9	37	2	BE90 AP10.016 Z02	●		
16	16	130	9	37	2	BE90 AP10.016 Z02 130	○		
20	20	90	9	40	3	BE90 AP10.020 Z03	●		
20	20	150	9	40	3	BE90 AP10.020 Z03 150	○		
25	25	105	9	49	4	BE90 AP10.025 Z04	●		
25	25	170	9	49	4	BE90 AP10.025 Z04 170	○		
32	25	110	9	54	5	BE90 AP10.032 Z05	●		
32	25	195	9	54	5	BE90 AP10.032 Z05 195	○		

Order example: 1 piece BE90 AP10.012 Z01

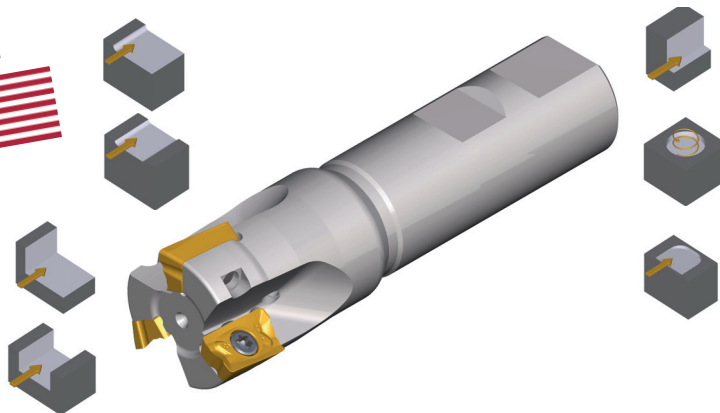
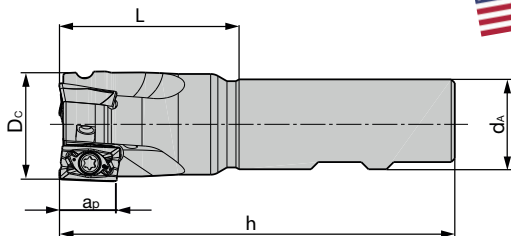
End milling cutter 90° / AP.T 10.. / inch





Dimensions in inch						Ordering code	Availability	Spare parts	
Dc	dA	h	ap	L	z [✱]				
0.500	0.625	3.25	0.354	1.25	1	BEU90 AP10.0500 Z01	●	 Fixation screw AP17-25055 5085710 M _A = 2Nm	 Torque wrench IP8 5088519
0.625	0.625	3.25	0.354	1.375	2	BEU90 AP10.0625 Z02	●		
0.750	0.750	3.375	0.354	1.5	3	BEU90 AP10.0750 Z03	●		
1.0	1.0	4.0	0.354	2.0	4	BEU90 AP10.1000 Z04	●		
1.25	1.0	4.0	0.354	2.0	5	BEU90 AP10.1250 Z05	●		

Order example: 1 piece BEU90 AP10.0500 Z01

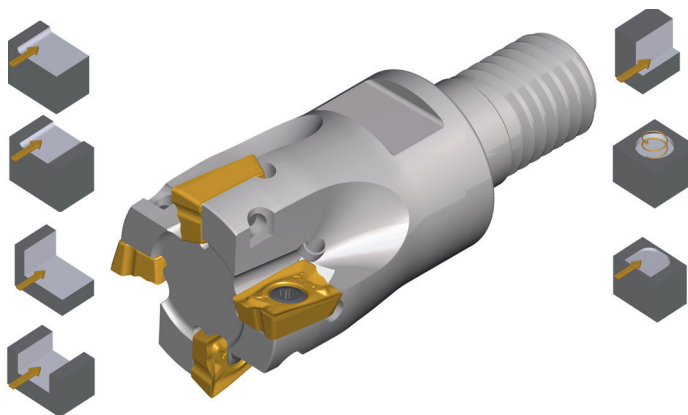
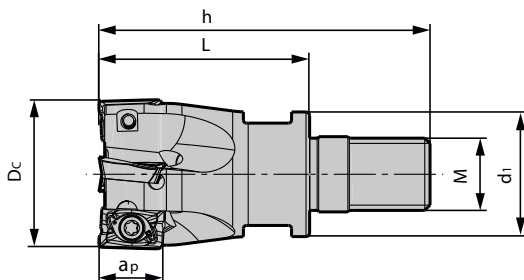
Screw on type 90° / AP.T 10.. / metric





Dimensions in mm							Ordering code	Availability	Spare parts	
Dc	d1	L	h	ap	M	z [±]				
16	12.7	23	41	9	M8	2	BS90 AP10.016 Z02 M08	●	 Fixation screw AP17-25055 5085710 M _A = 2Nm	 Torque wrench IP8 5088519
20	17.7	30	50	9	M10	3	BS90 AP10.020 Z03 M10	●		
25	20.7	35	57	9	M12	4	BS90 AP10.025 Z04 M12	●		
32	28.7	43	67	9	M16	5	BS90 AP10.032 Z05 M16	●		

Order example: 1 piece BS90 AP10.016 Z02 M08

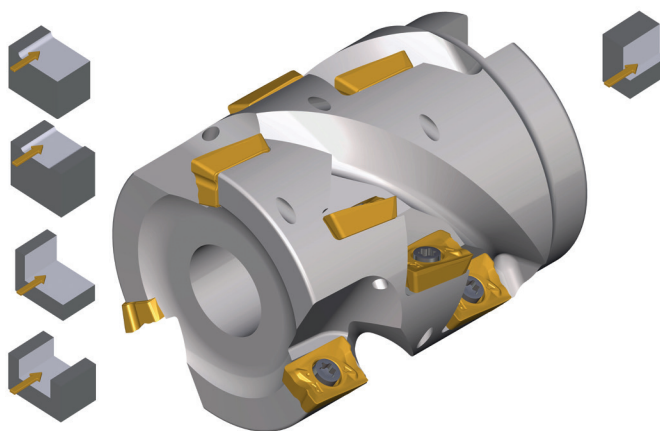
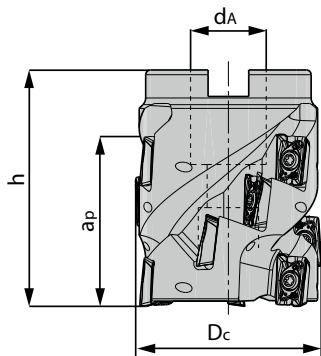
Face milling cutter 90° / AP.T 10.. / metric



Dimensions in mm						Ordering code	Availability	Spare parts	
Dc	da	h	ap/90°	z [±]	Pieces Insert				
40	16	50	37	3	12	BFH90 AP10.040 Z03 037	●	 Fixation screw AP17-25055 5085710 M _A = 2Nm	 Torque wrench IP8 5088519
40	16	50	37	5	20	BFH90 AP10.040 Z05 037	●		
50	22	60	46	3	15	BFH90 AP10.050 Z03 046	●		
50	22	60	46	5	25	BFH90 AP10.050 Z05 046	●		
63	27	60	46	4	20	BFH90 AP10.063 Z04 046	●		
63	27	60	46	7	35	BFH90 AP10.063 Z07 046	●		

Order example: 1 piece BFH90 AP10.040 Z03 037

End milling cutter 90° / APT 10.. / metric

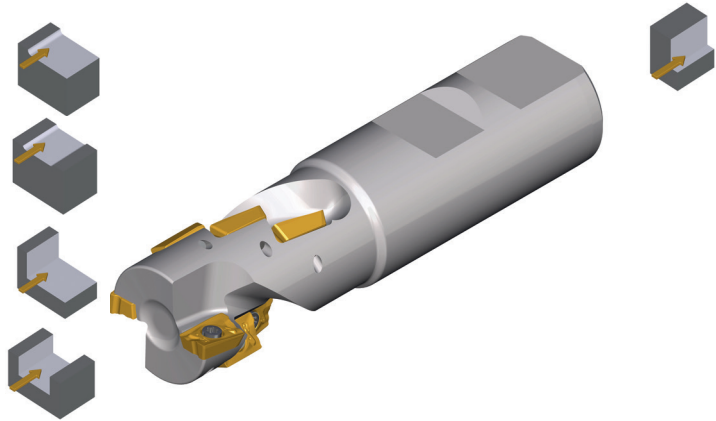
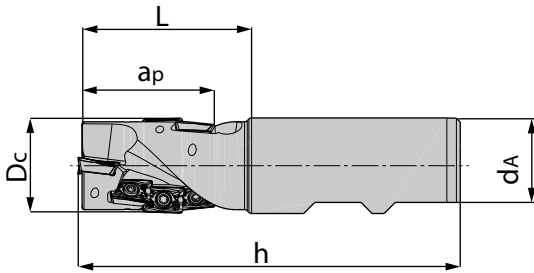

Dimensions in mm							Ordering code	Availability	Spare parts	
Dc	dA	L	h	ap/90°	z	Pieces Insert				
20	20	37	87	28	2	6	BEH90 AP10.020 Z02 028	●	 Fixation screw AP17-25055 5085710 MA = 2Nm Torque wrench IP8 5088519	
25	25	49	105	37	2	8	BEH90 AP10.025 Z02 037	●		
32	32	55	115	46	2	10	BEH90 AP10.032 Z02 046	●		
32	32	55	115	46	3	15	BEH90 AP10.032 Z03 046	●		
40	32	70	130	55	3	18	BEH90 AP10.040 Z03 055	●		



Order example: 1 piece BEH90 AP10.020 Z02 028

Insert Size 10							Cutting materials Ident No.											
N = Number of cutting edges	Ordering code	l	d	s	d ₁	r	BCP20M	BCP25M	BCP30M	BCP35M	BCP40M	BCM35M	BCM40M	BCK15M	BCK20M	BCN10M	BWN10M	
							 	APHT 100304 FR-MN2	10	6.7	3.5	2.8	0.4					
APKT 100304 SR-MP2	10	6.7	3.5	2.8	0.4	●				●								
APKT 100304 SR-MM2	10	6.7	3.5	2.8	0.4								●					
APKT 100304 SR-RP2	10	6.7	3.5	2.8	0.4					●	●	●						
APKT 100304 SR-RK2	10	6.7	3.5	2.8	0.4										●	●		

N = 2
Order example: 10 pieces APHT 100304 FR-MN2 BCN10M

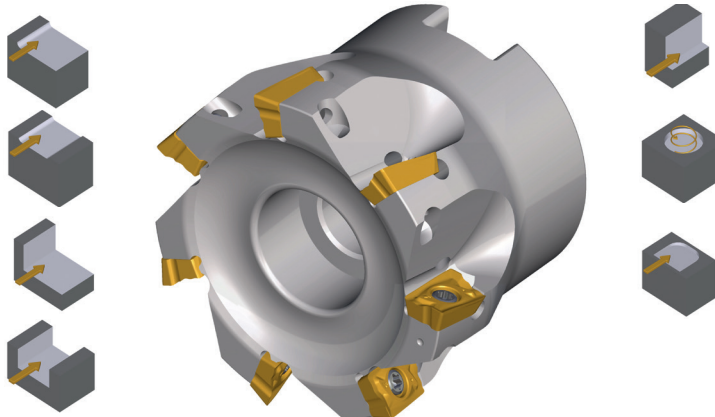
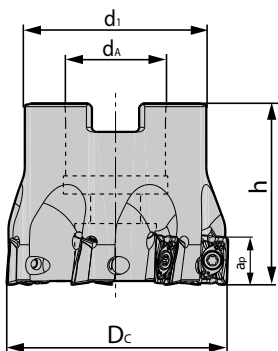
Face milling cutter 90°/ APT 16.. / metric





Dimensions in mm						Ordering code	Availability	Spare parts	
Dc	dA	d1	ap	h	z [☆]				
40	16	32	15	40	4	BF90 AP16.040 Z04	●	 Fixation screw AP02-40095 5085711 MA= 3Nm	 Torque wrench IP15 5088520
50	22	42	15	40	5	BF90 AP16.050 Z05	●		
63	22	48	15	40	6	BF90 AP16.063 Z06	●		
80	27	58	15	50	7	BF90 AP16.080 Z07	●		
100	32	76	15	50	8	BF90 AP16.100 Z08	●		
125	40	90	15	63	9	BF90 AP16.125 Z09	●		

Order example: 1 piece BF90 AP16.040 Z04

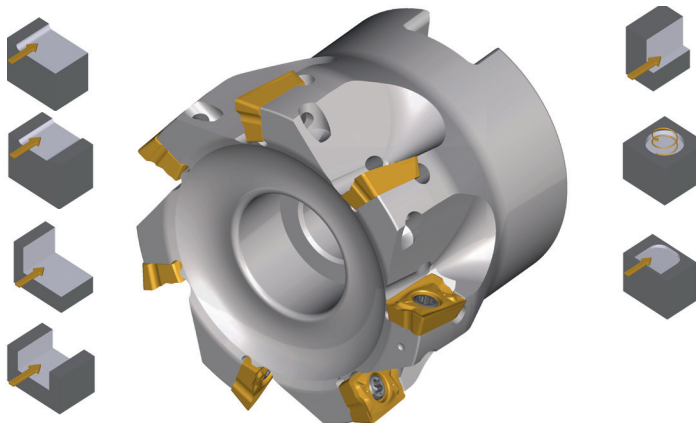
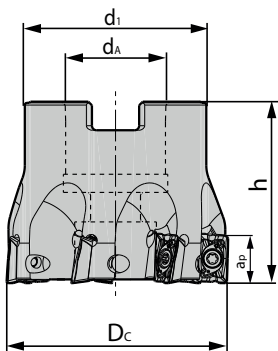
Face milling cutter 90°/ APT 16.. / inch





Dimensions in inch						Ordering code	Availability	Spare parts	
Dc	dA	d1	ap	h	z [☆]				
2.0	0.75	1.75	0.590	1.5	5	BFU90 AP16.2000 Z05	●	 Fixation screw AP02-40095 5085711 MA= 3Nm	 Torque wrench IP15 5088520
2.5	1.0	2.25	0.590	1.75	6	BFU90 AP16.2500 Z06	●		
3.0	1.0	2.25	0.590	1.75	7	BFU90 AP16.3000 Z07	●		
4.0	1.5	3.75	0.590	2.25	8	BFU90 AP16.4000 Z08	●		
5.0	1.5	3.75	0.590	2.5	9	BFU90 AP16.5000 Z09	●		

Order example: 1 piece BFU90 AP16.2000 Z05

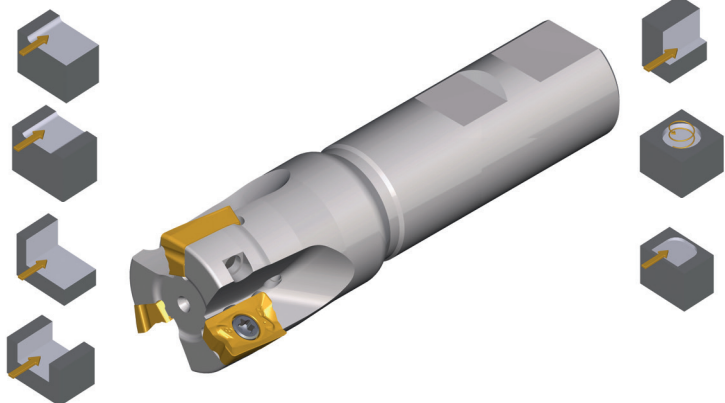
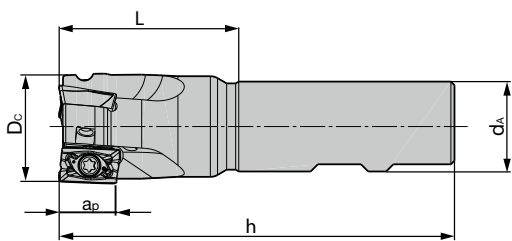
End milling cutter 90° / APT 16.. / metric





Dimensions in mm						Ordering code	Availability	Spare parts	
Dc	dA	h	ap	L	z [✱]				
25	20	100	15	40	2	BE90 AP16.025 Z02	●	 Fixation screw AP02-40095 5085711 M _A = 3Nm	 Torque wrench IP15 5088520
25	20	200	15	40	2	BE90 AP16.025 Z02 200	○		
32	25	110	15	50	3	BE90 AP16.032 Z03	●		
32	25	200	15	50	3	BE90 AP16.032 Z03 200	○		
40	32	115	15	55	4	BE90 AP16.040 Z04	●		

Order example: 1 piece BE90 AP16.025 Z02

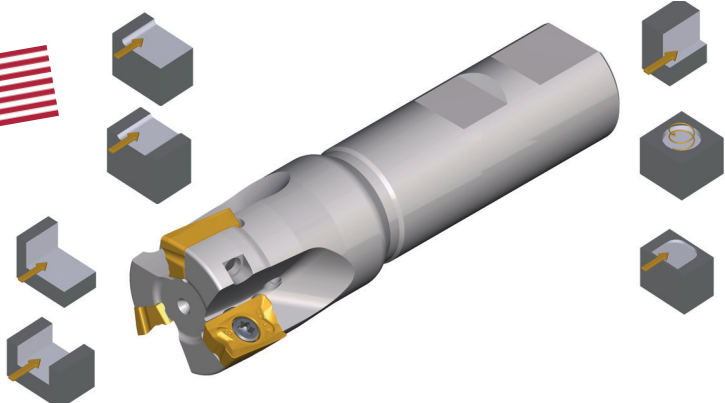
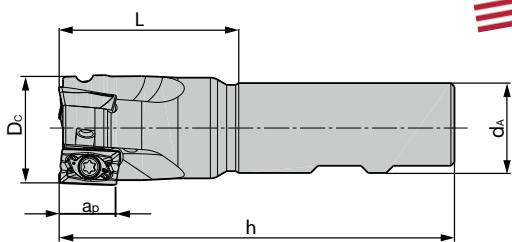
End milling cutter 90° / APT 16.. / inch





Dimensions in inch						Ordering code	Availability	Spare parts	
Dc	dA	h	ap	L	z [✱]				
1.0	1.0	4.0	0.590	2.0	2	BEU90 AP16.1000 Z02	●	 Fixation screw AP02-40095 5085711 M _A = 3Nm	 Torque wrench IP15 5088520
1.25	1.0	4.5	0.590	2.25	3	BEU90 AP16.1250 Z03	●		
1.5	1.25	4.5	0.590	2.25	4	BEU90 AP16.1500 Z04	●		

Order example: 1 piece BEU90 AP16.1000 Z02

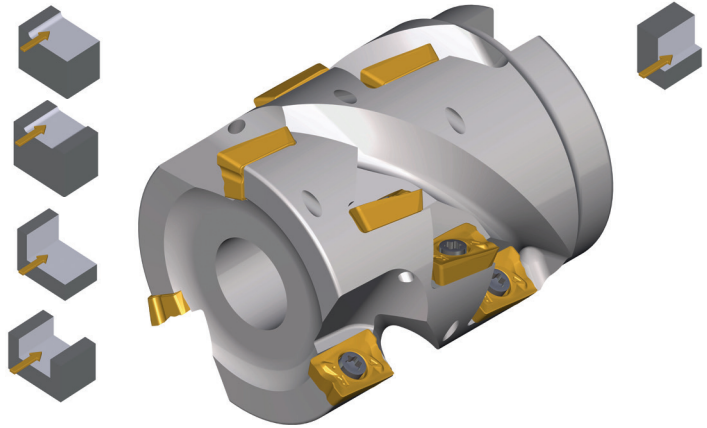
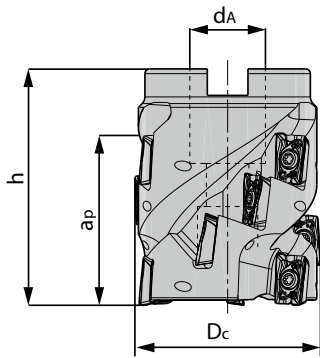
Face milling cutter 90° / APT 16.. / metric





Dimensions in mm							Ordering code	Availability	Spare parts	
Dc	da	h	ap/90°	Z	Pieces Insert					
50	27	50	30	3	6	BFH90 AP16.050 Z03 030	<input type="checkbox"/>	 Fixation screw AP02-40095 5085711 $M_A = 3Nm$	 Torque wrench IP15 5088520	
63	27	60	44	4	12	BFH90 AP16.063 Z04 044	<input type="checkbox"/>			
80	32	60	44	5	15	BFH90 AP16.080 Z05 044	<input type="checkbox"/>			
100	40	60	44	6	18	BFH90 AP16.100 Z06 044	<input type="checkbox"/>			
125	40	60	44	7	21	BFH90 AP16.125 Z07 044	<input type="checkbox"/>			

Order example: 1 piece BFH90 AP16.050 Z03 030

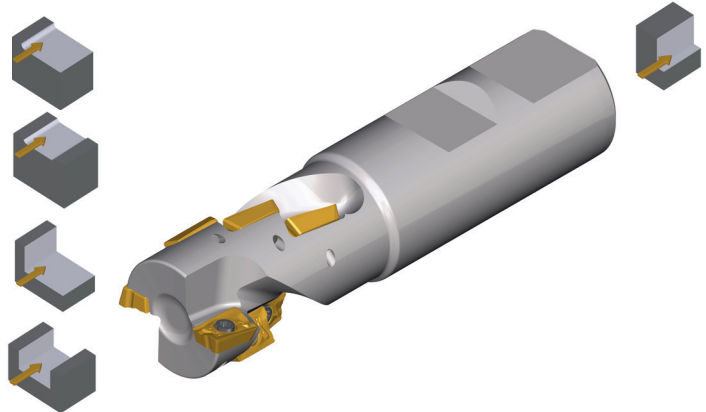
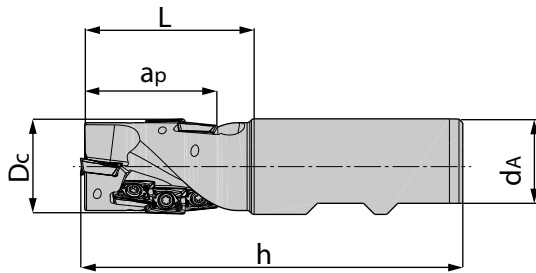
End milling cutter 90° / APT 16.. / metric



Dimensions in mm							Ordering code	Availability	Spare parts	
Dc	da	L	h	ap/90°	Z	Pieces Insert				
25	25	38	95	29	1	3	BEH90 AP16.025 Z01 029	<input type="checkbox"/>	 Fixation screw AP02-40095 5085711 $M_A = 3Nm$	 Torque wrench IP15 5088520
32	32	53	115	44	2	6	BEH90 AP16.032 Z02 044	<input type="checkbox"/>		
40	32	65	130	58	2	6	BEH90 AP16.040 Z02 058	<input type="checkbox"/>		

Order example: 1 piece BEH90 AP16.025 Z01 029

- Available from stock
- On request
- Available 4th quarter 2018

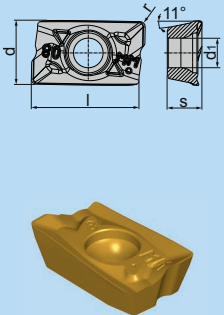
Insert Size 16							Cutting materials Ident No.										
N = Number of cutting edges	Ordering code	l	d	s	d ₁	r	BCP20M	BCP25M	BCP30M	BCP35M	BCP40M	BCM35M	BCM40M	BCK15M	BCK20M	BCN10M	BWN10M
							 N = 2	APHT 160408 FR-MN2	16	9.52	5.26	4.5	0.8				
APKT 160408 SR-MP2	16	9.52	5.26	4.5	0.8	●			●								
APKT 160408 SR-MM2	16	9.52	5.26	4.5	0.8						●						
APKT 160408 SR-RP2	16	9.52	5.26	4.5	0.8				●	●	●						
APKT 160408 SR-RK2	16	9.52	5.26	4.5	0.8									●	●		

Order example: 10 pieces APHT 160408 FR-MN2 BCN10M

- Available from stock
- On request
- Available 4th quarter 2018

Ø 50 mm - 250 mm
Face Milling Cutter
Insert size 12

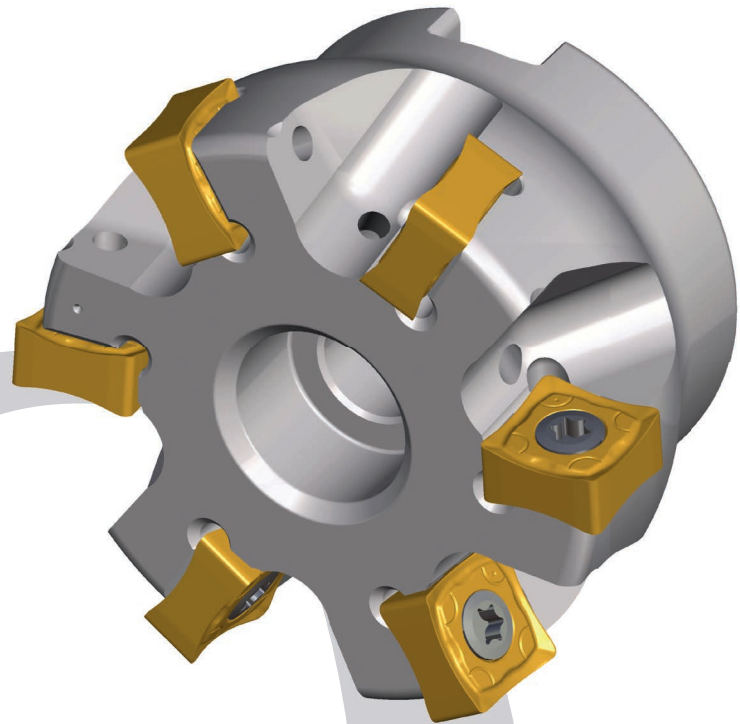

Special features:

- Stable edge milling (roughing)
- Approach angle 88° with 8 cutting edges
- 0.8 or 1.2 corner radius available
- Narrow and very narrow division of the tools
- From diameter 160 no internal coolant supply
- Article with status "On request" are deliverable in five working days

SN.. 12..

Insert geometry	Cutting depth [mm] a_p max	Feed [mm] f_z
MP	1 5 10	0.1 0.2 0.25
MM	1 5 10	0.1 0.18 0.22
MK	1 5 10	0.1 0.2 0.25

Face milling cutter 88° for SNMX... / metric

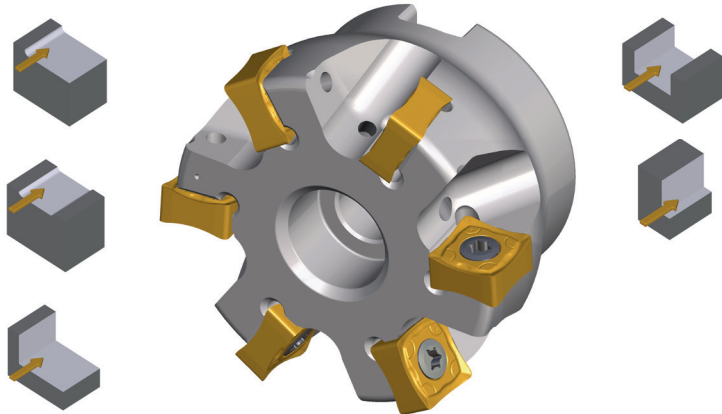
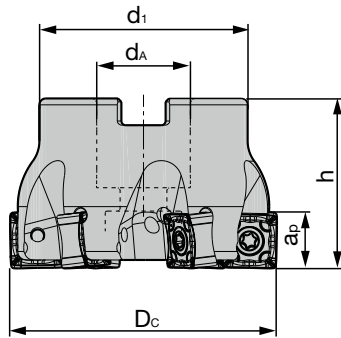

Dimensions in mm						Ordering code	Availability	Spare parts	
Dc	dA	d1	h	ap	z [✱]			 Fixation screw AP06-40115 5131917 MA = 5Nm	 Torque wrench IP20 5088521
50	22	42	40	10	4	BF88 SN12.050 Z04	○		
63	22	49	40	10	6	BF88 SN12.063 Z06	○		
80	27	60	50	10	7	BF88 SN12.080 Z07	○		
80	27	60	50	10	9	BF88 SN12.080 Z09	○		
100	32	80	50	10	8	BF88 SN12.100 Z08	○		
100	32	80	50	10	11	BF88 SN12.100 Z11	○		
125	40	95	63	10	10	BF88 SN12.125 Z10	○		
125	40	95	63	10	14	BF88 SN12.125 Z14	○		
160	40	115	63	10	12	BF88 SN12.160 Z12 NC	○		
160	40	115	63	10	18	BF88 SN12.160 Z18 NC	○		
200	60	164	63	10	14	BF88 SN12.200 Z14 NC	○		
200	60	164	63	10	22	BF88 SN12.200 Z22 NC	○		
250	60	184	63	10	16	BF88 SN12.250 Z16 NC	○		
250	60	184	63	10	24	BF88 SN12.250 Z24 NC	○		

Order example: 1 piece BF88 SN12.050 Z04

Insert Size 10							Cutting materials Ident No.										
N = Number of cutting edges	Ordering code	l	d	s	d ₁	r	BCP20M	BCP25M	BCP30M	BCP35M	BCP40M	BCM35M	BCM40M	BCK15M	BCK20M	BCN10M	BWN10M
							 N = 8	SNMX 120608 SN-MP	12.70	12.70	6.35	5.2	0.8			●	●
SNMX 120608 SN-MM	12.70	12.70	6.35	5.2	0.8							●					
SNMX 120608 SN-MK	12.70	12.70	6.35	5.2	0.8									●	●		
SNMX 120612 SN-MP	12.70	12.70	6.35	5.2	1.2				●	●							
SNMX 120612 SN-MK	12.70	12.70	6.35	5.2	1.2									●	●		

Order example: 10 pieces SNMX 120608 SN-MP BCP30M

Ø 32 mm - 160 mm
Face Milling Cutter
Insert size 04 and 08

Ø 2" - 6" Face Milling Cutter
Insert size 08

Ø 20 mm - 32 mm
End Milling Cutter
Insert size 04

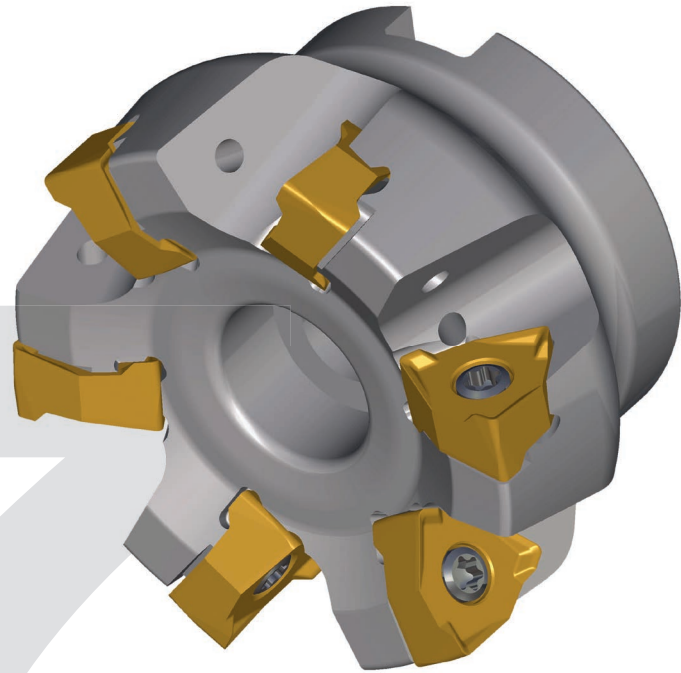

Special features: Milling 90°

- Stable tool system through negative geometry basic design therefore process security on roughing
- 6 cutting edges for increase of productivity on 90° face milling
- Effective positive chip angle for smooth cut
- Productivity guaranteed through 6 cutting edges

WNEX 04..

Insert geometry	Cutting depth [mm] a_p max WNEX 04	Feed [mm] f_z WNEX 04
MP	0.4 2 4	0.12 0.18 0.25
MM	0.4 2 4	0.10 0.15 0.20
MK	0.4 2 4	0.14 0.20 0.26

WNEX 08..

Insert geometry	Cutting depth [mm] a_p max WNEX 08	Feed [mm] f_z WNEX 08
RP	1 4 7	0.15 0.22 0.3
RK	1 4 7	0.18 0.25 0.35
RM	1 4 7	0.15 0.2 0.28
MN	1 4 7	0.2 0.3 0.4



90° Ramping angle

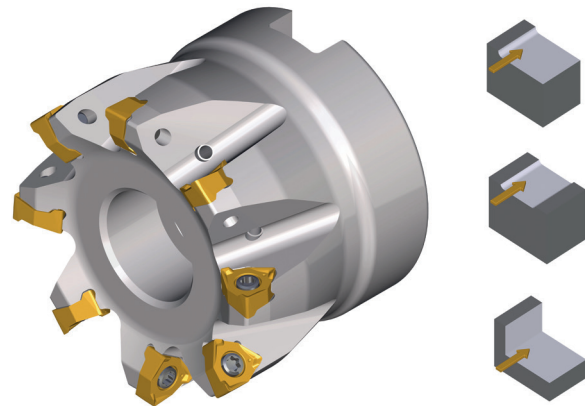
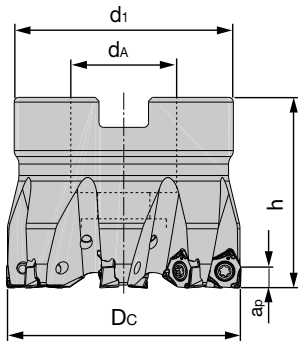

Diameter Milling cutter	Ramping angle 90° milling cutter a max. WNEX 08
Ø 40	0.50°
Ø 50	0.46°
Ø 63	0.36°
Ø 80	0.23°
Ø 100	0.17°
Ø 125	0.12°
Ø 160	0.07°

Face milling cutter 90° for WNEX 04.. / metric





Dimensions in mm						Ordering code	Availability	Spare parts	
Dc	dA	d1	h	ap	z [☆]				
32	16	30	40	4	6	BF90 WN04.032 Z06	○	 Fixation screw AP02-25064 5127961 $M_A = 1.5Nm$	 Torque wrench IP7 5118123
40	16	36	40	4	6	BF90 WN04.040 Z06	○		
50	22	46	40	4	8	BF90 WN04.050 Z08	○		
63	22	48	40	4	9	BF90 WN04.063 Z09	○		

Order example: 1 piece BF90 WN04.032 Z06

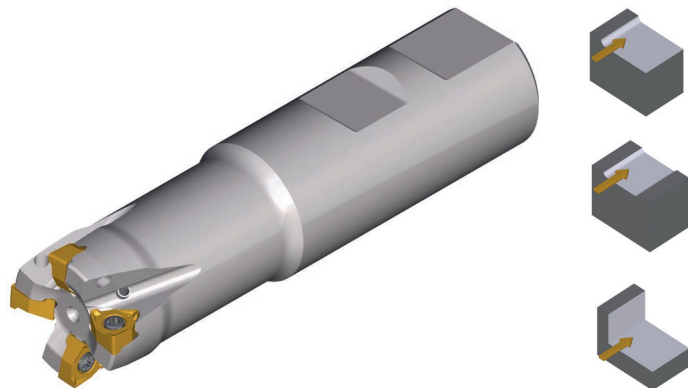
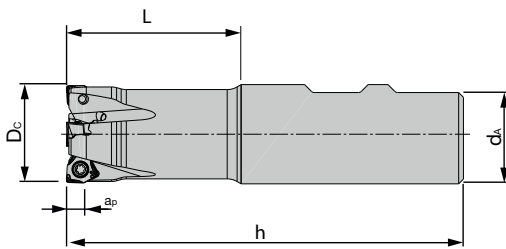
End milling cutter 90° for WNEX 04.. / metric



Dimensions in mm						Ordering code	Availability	Spare parts	
Dc	dA	L	h	ap	z [☆]				
20	20	40	90	4	3	BE90 WN04.020 Z03	○	 Fixation screw AP02-25064 5127961 $M_A = 1.5Nm$	 Torque wrench IP7 5118123
25	25	44	100	4	4	BE90 WN04.025 Z04	○		
32	32	50	110	4	5	BE90 WN04.032 Z05	○		

Order example: 1 piece BF90 WN04.020 Z03

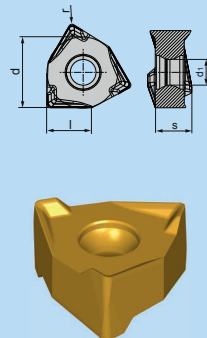

● Available from stock
○ On request

Insert Size 04							Cutting materials Ident No.										
N = Number of cutting edges	Ordering code	l	d	s	d ₁	r	BCP20M	BCP25M	BCP30M	BCP35M	BCP40M	BCM35M	BCM40M	BCK15M	BCK20M	BCN10M	BWN10M
								WNEX 040304-MP	4	6.7	3.97	3.2	0.4		<input type="checkbox"/>		<input type="checkbox"/>
	WNEX 040304-MM	4	6.7	3.97	3.2	0.4						<input type="checkbox"/>					
	WNEX 040304-MK	4	6.7	3.97	3.2	0.4								<input type="checkbox"/>			

Order example: 10 pieces WNEX 040304-MP BCP25M
Description of grades page 114

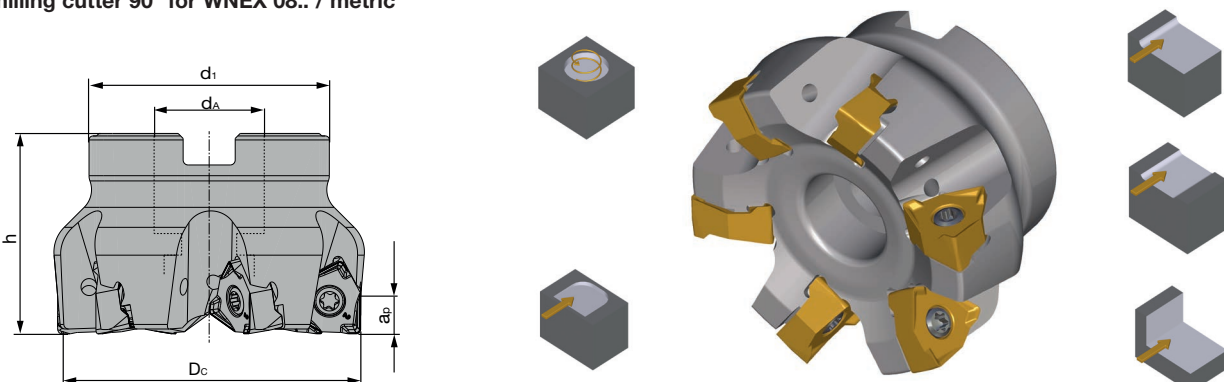
Face milling cutter 90° for WNEX 08.. / metric



Dimensions n mm						Ordering code	Availability	Spare parts	
Dc	dA	d1	h	ap	z [±]				
40	16	36	40	4	3	BF90 WN08.040 Z03	○		
50	22	46	40	4	4	BF90 WN08.050 Z04	○	 Fixation screw AP02-40054 5085714 M _A = 3Nm	 Torque wrench IP15 5088520
50	22	46	40	4	5	BF90 WN08.050 Z05	●		
63	22	47	40	4	6	BF90 WN08.063 Z06	●		
63	22	47	40	4	7	BF90 WN08.063 Z07	○		
80	27	62	50	4	7	BF90 WN08.080 Z07	●		
80	27	62	50	4	9	BF90 WN08.080 Z09	○		
100	32	78	50	4	8	BF90 WN08.100 Z08	●		
100	32	78	50	4	10	BF90 WN08.100 Z10	○		
125	40	90	63	4	10	BF90 WN08.125 Z10	●		
125	40	90	63	4	11	BF90 WN08.125 Z11	○		
160	40	90	63	4	11	BF90 WN08.160 Z11	●		
160	40	90	63	4	12	BF90 WN08.160 Z12	○		



Order example: 1 piece BF90 WN08.040 Z03

Cutting data recommendations page 82-83

- Available from stock
- On request
- Available 4th quarter 2018

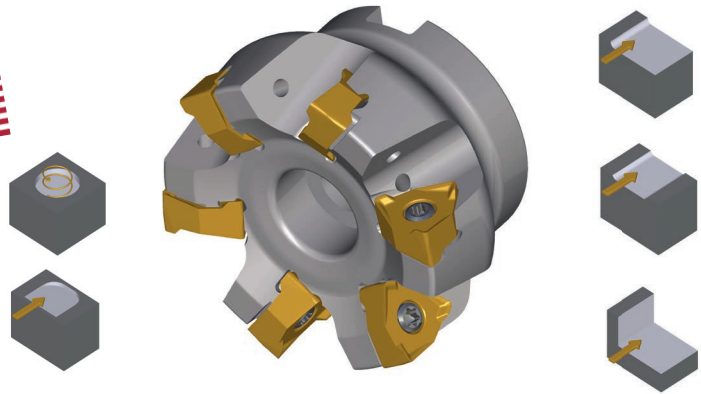
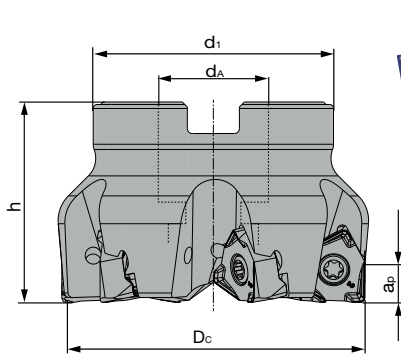
Face milling cutter 90° for WNEX 08.. / inch



Dimensions in inch						Ordering code	Availability	Spare parts	
Dc	dA	d1	h	ap	z [☆]				
2.0	0.75	1.75	1.5	0.158	5	BFU90 WN08.2000 Z05	●	 Fixation screw AP02-40054 5085714 $M_A = 3Nm$	 Torque wrench IP15 5088520
2.5	1.0	2.25	1.75	0.158	6	BFU90 WN08.2500 Z06	●		
3.0	1.0	2.25	1.75	0.158	7	BFU90 WN08.3000 Z07	●		
4.0	1.5	3.75	2.25	0.158	8	BFU90 WN08.4000 Z08	●		
5.0	1.5	3.75	2.5	0.158	10	BFU90 WN08.5000 Z10	●		
6.0	1.5	3.75	2.5	0.158	11	BFU90 WN08.6000 Z11	●		

Order example: 1 piece BFU90 WN08.2000 Z05

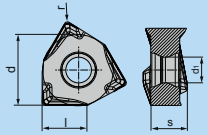
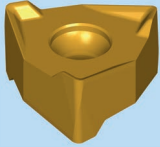
Insert Size 08							Cutting materials Ident No.											
N = Number of cutting edges	Ordering code	l	d	s	d ₁	r	BCP20M	BCP25M	BCP30M	BCP35M	BCP40M	BCM35M	BCM40M	BCK15M	BCK20M	BCN10M	BWN10M	
							  N = 6	WNEX 080608-RP	8	12.7	6.55	4.6	0.8	●	●			
	WNEX 080608-RK	8	12.7	6.55	4.6	0.8									●			
	WNEX 080608-RM	8	12.7	6.55	4.6	0.8					●	●						
	WNEX 080608-MN	8	12.7	6.55	4.6	0.8										●	●	

Order example: 10 pieces WNEX 080608-RP BCP25M

- Available from stock
- On request
- Available 4th quarter 2018

Cutting Speed Recommendations for Milling Cutter 90°

Material group	Insert grade				BCP20M P20	BCP25M P25	BCP30M P30	BCP35M P35	BCP40M P40	
	ISO Code		Dry machining	Wet machining						
	Material									
P	Structural steel		●	○	190-290	190-290	160-240	150-230	100-220	
	Heat treated steel		●	○	160-230	160-230	140-190	130-180	145-215	
	Tool steel		●	○	145-210	145-210	120-175	110-160	130-190	
	Heat treated steel		high strength	●	○	110-170	110-170	100-160		
M	Stainless steel		austenitic	●	○	90-150		80-140	70-130	
			austenitic hardened	●	○	60-110				
K	Grey cast iron		●	○	140-300					
	Nodular graphite cast iron		●	○	100-160					
N	Aluminium		●	○						
	Copper and copper alloys		●	○						
S	Heat resistant alloys		○	●						
	Titanium alloys		○	●						
H	Chilled cast iron		Hardness 300-600 HB	●	○					
	Hardened steel		45-52 HRC	●	○	100-150	100-150			
	Hardened steel		53-58 HRC	●	○	100-150	100-150			
	Hardened steel		59-63 HRC	●	○	100-150	100-150			

- recommended application
- alternative application reduced by 30 - 50 %

BCM35M M35	BCM40M M40	BCK15M K15	BCK20M K20	BCN10M N10	BCN15M N15	BWN10M N10	BCS35M S35	BCH03M	BCH05M	BCH10M	BCH23M	BCH30M
		200-350	200-300						250-350	220-300		180-250
		200-300	180-250						200-300	180-250		150-220
		180-250	160-220						180-250	160-220		140-200
		150-200	120-180						150-200	120-200		100-180
110-180	100-160						100-150					100-160
80-130	70-120						80-120			80-150		60-100
		180-360	150-320						200-380	180-320		
		140-250	110-180						160-280	180-300		
				500-3000	500-3000	400-2500						
				160-500	160-500	120-400						
30-65	30-60						30-80					
30-65	30-60						30-80					
		80-120	80-120						70-100	65-95		60-90
									100-150	95-145		80-120
									70-80	65-75		-
									-	-		-

ZETAtec 90N - Roughing
without worrying about the costs

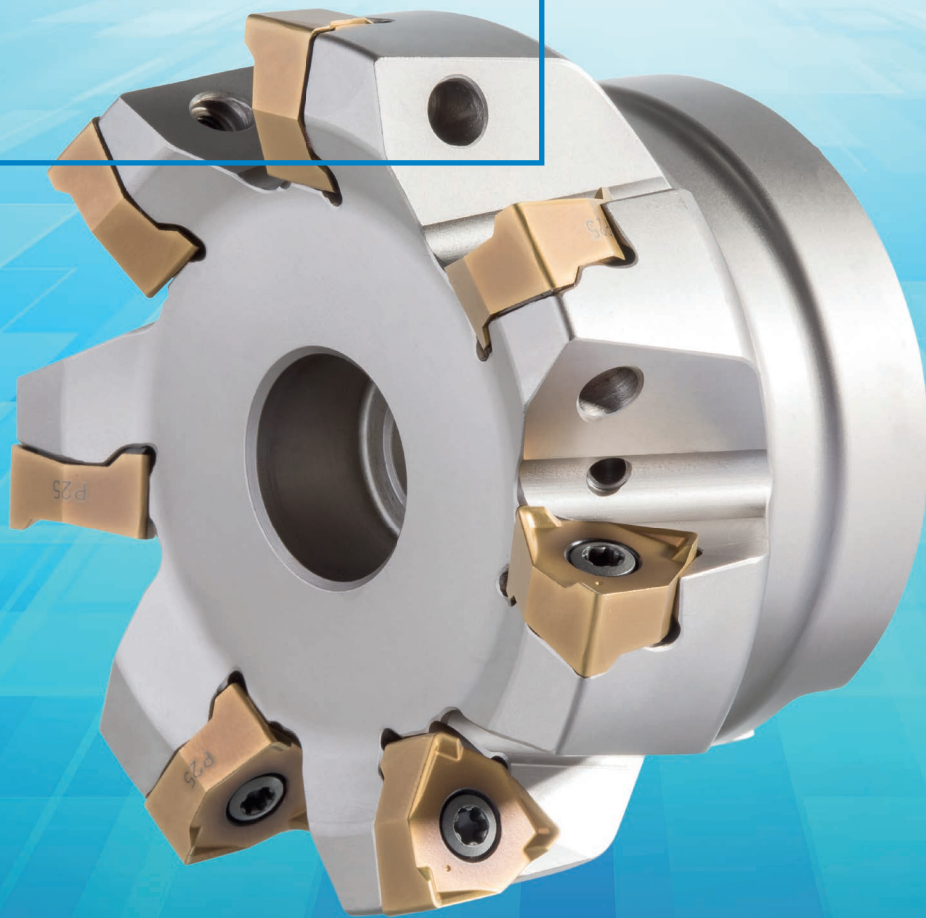

3D-Milling

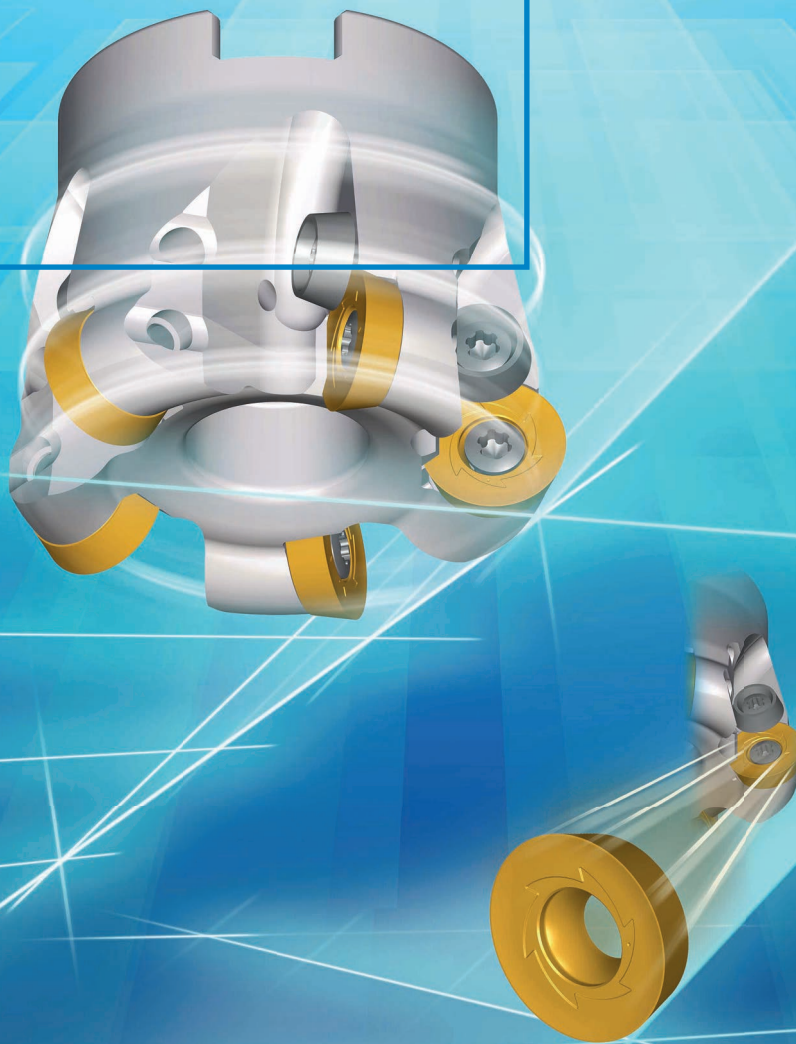

Ø 40 mm - 160 mm Face Milling Cutter
Insert size 10, 12 and 16

Ø 1 1/2" - 5"
Insert Size 10, 12, 16

Ø 15 mm - 20 mm End Milling Cutter
Insert size 07 and 10

Ø 10 mm - 42 mm Screw on type
Insert size 05, 07, 10, 12 and 16

Special features: Milling HFC

- Universal applicable tool system for general machining and mould construction
- Neutral mounting position of the insert in the tool for an optimal contour precision
- Special protection against chip impact on the insert seat of the insert's cutting edge
- Big assortment depth of inserts and tools
- Smooth cutting behaviour due to special geometry of inserts, despite neutral mounting position

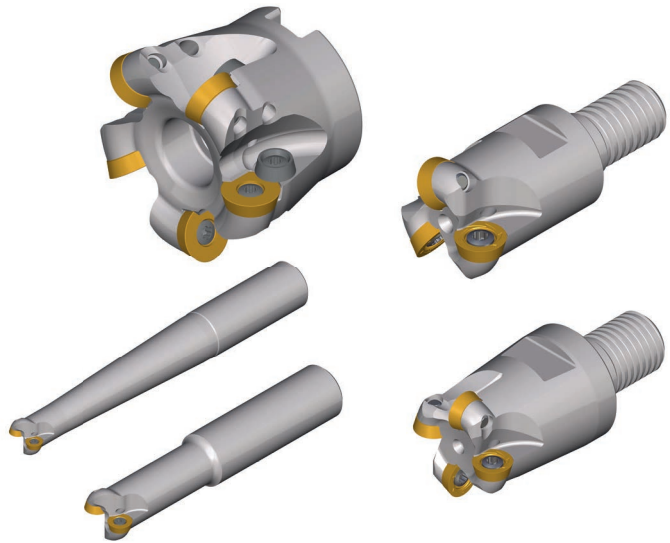

RD.. 0501..

Insert geometry	"Cutting depth [mm] ap max" RD.. 0501	"Feed [mm] fz" RD.. 0501
MP	0.25 0.70 1.20	0.14 0.26 0.50
MM	0.25 0.70 1.20	0.13 0.23 0.45
MK	0.25 0.70 1.20	0.15 0.27 0.53
MH	0.10 0.18 0.45	0.10 0.20 0.36
RH	0.12 0.24 0.60	0.10 0.22 0.40

RD.. 0702..

Insert geometry	"Cutting depth [mm] ap max" RD.. 0701	"Feed [mm] fz" RD.. 0701
MP	0.25 1.00 1.70	0.14 0.27 0.60
MM	0.25 1.00 1.70	0.13 0.24 0.52
MK	0.25 1.00 1.70	0.15 0.28 0.63
MH	0.10 0.20 0.65	0.11 0.22 0.42
RH	0.12 0.25 0.85	0.11 0.25 0.46

RD.. 1003..

Insert geometry	"Cutting depth [mm] ap max" RD.. 1003	"Feed [mm] fz" RD.. 1003
MP	0.28 1.50 2.50	0.15 0.28 0.64
MM	0.26 1.50 2.50	0.14 0.25 0.55
MK	0.28 1.50 2.50	0.16 0.30 0.67
MH	0.12 0.22 0.90	0.12 0.28 0.45
RH	0.14 0.28 1.20	0.12 0.30 0.50

RD.. 12T3..

Insert geometry	"Cutting depth [mm] ap max" RD.. 12T3	"Feed [mm] fz" RD.. 12T3
MP	0.30 1.80 3.00	0.16 0.29 0.70
MM	0.27 1.80 3.00	0.15 0.25 0.60
MK	0.30 1.80 3.00	0.18 0.32 0.75
MH	0.12 0.25 1.10	0.13 0.28 0.50
RH	0.14 0.30 1.50	0.13 0.30 0.56

RD.. 1604..

Insert geometry	"Cutting depth [mm] ap max" RD.. 1604	"Feed [mm] fz" RD.. 1604
MP	0.30 2.40 4.00	0.18 0.30 0.75
MM	0.27 2.40 4.00	0.16 0.25 0.64
MK	0.30 2.40 4.00	0.18 0.33 0.80
MH	0.12 0.28 1.60	0.14 0.28 0.50
RH	0.15 0.35 2.00	0.14 0.30 0.56

Face milling cutter / metric

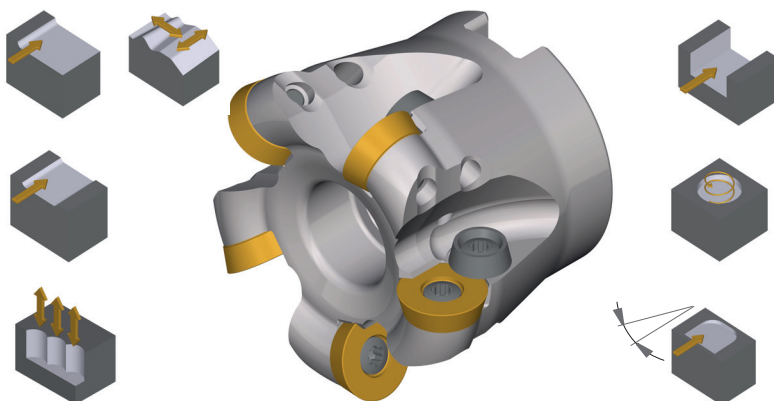
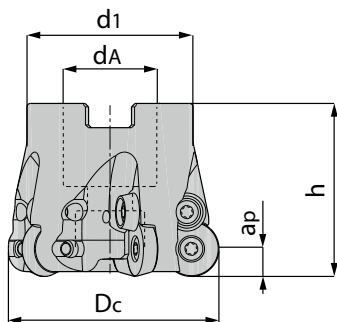

Dimension in mm						Ordering code	Availability		Spare parts		
Dc	dA	d1	h	ap	z						
40	16	32	40	5	5	BF00 RD10.040 Z05	●	RD.. 10	AP13-35072 5118118 MA = 3.5Nm	IP15 5088520	-
42	16	32	40	5	5	BF00 RD10.042 Z05	●	RD.. 10			
52	22	40	50	5	5	BF00 RD10.052 Z05	●	RD.. 10			
52	22	40	50	5	7	BF00 RD10.052 Z07	●	RD.. 10			
42	16	32	40	6	4	BF00 RD12.042 Z04	●	RD.. 12	AP13-35086 5118120 MA = 3.5Nm	IP15 5088520	 Clamping screw RD12 5125841
48	22	40	50	6	4	BF00 RD12.048 Z04	●	RD.. 12			
50	22	40	50	6	5	BF00 RD12.050 Z05	●	RD.. 12			
52	22	40	50	6	5	BF00 RD12.052 Z05	●	RD.. 12			
63	27	48	50	6	6	BF00 RD12.063 Z06	●	RD.. 12			
66	27	48	50	6	6	BF00 RD12.066 Z06	●	RD.. 12			
80	27	60	52	6	7	BF00 RD12.080 Z07	●	RD.. 12			
50	22	40	50	8	4	BF00 RD16.050 Z04	●	RD.. 16	AP13-45105 5118121 MA = 5Nm	IP15 5088520	 Clamping system : Clamp 5125842 Clamping screw 5118121
52	22	40	50	8	4	BF00 RD16.052 Z04	●	RD.. 16			
63	27	48	50	8	5	BF00 RD16.063 Z05	●	RD.. 16			
66	27	48	50	8	5	BF00 RD16.066 Z05	●	RD.. 16			
66	27	48	50	8	6	BF00 RD16.066 Z06	●	RD.. 16			
80	27	60	52	8	6	BF00 RD16.080 Z06	●	RD.. 16			
80	27	60	52	8	7	BF00 RD16.080 Z07	●	RD.. 16			
100	32	75	52	8	7	BF00 RD16.100 Z07	●	RD.. 16			
125	40	90	63	8	8	BF00 RD16.125 Z08	●	RD.. 16			
160	40	120	63	8	9	BF00 RD16.160 Z09	●	RD.. 16			

Order example: 1 piece BF00 RD10.040 Z05

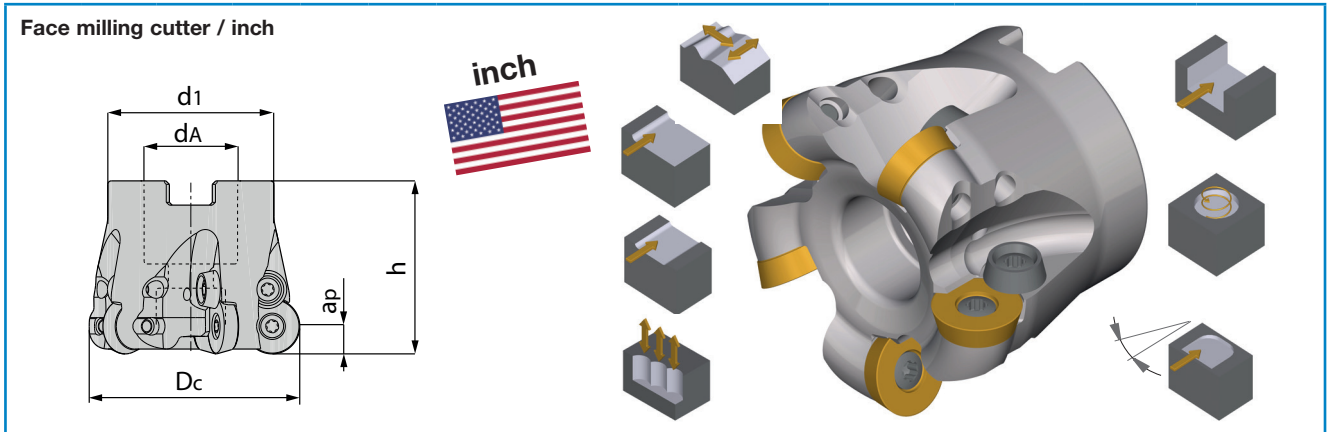

Dimension in inch						Ordering code	Availability		Spare parts		
Dc	dA	d1	h	ap	z						
1.5	0.75	1.375	1.5	0.197	5	BFU00 RD10.1500 Z05	●	RD.. 10	AP13-35072 5118118 MA = 3.5Nm	IP15 5088520	-
2.0	0.75	1.70	2.0	0.197	7	BFU00 RD10.2000 Z07	●	RD.. 10			
2.0	0.75	1.70	2.0	0.236	5	BFU00 RD12.2000 Z05	●	RD.. 12	AP13-35086 5118120 MA = 3.5Nm	IP15 5088520	 Clamping screw RD12 5125841
2.5	1.0	2.20	2.0	0.236	6	BFU00 RD12.2500 Z06	●	RD.. 12			
3.0	1.0	2.30	2.0	0.236	7	BFU00 RD12.3000 Z07	●	RD.. 12			
2.0	0.75	1.70	2.0	0.315	4	BFU00 RD16.2000 Z04	●	RD.. 16	AP13-45105 5118121 MA = 5Nm	IP15 5088520	 Clamping system : Clamp 5125842 Clamping screw 5118121
2.5	1.0	2.20	2.0	0.315	5	BFU00 RD16.2500 Z05	●	RD.. 16			
3.0	1.0	2.30	2.0	0.315	6	BFU00 RD16.3000 Z06	●	RD.. 16			
4.0	1.5	3.10	2.0	0.315	7	BFU00 RD16.4000 Z07	●	RD.. 16			
5.0	1.5	3.50	2.5	0.315	8	BFU00 RD16.5000 Z08	●	RD.. 16			

Order example: 1 piece BFU00 RD10.1500 Z05

End milling cutter form A / metric

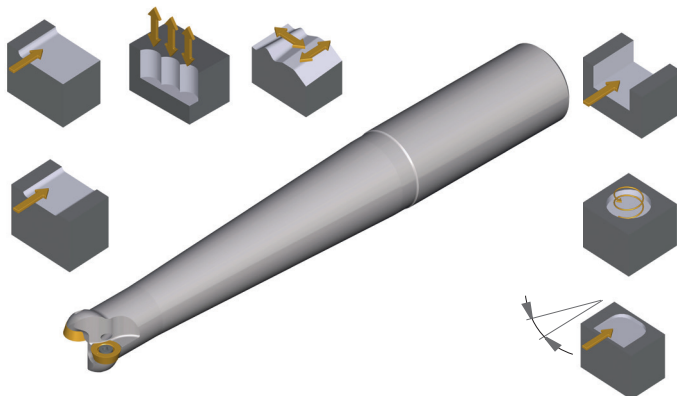
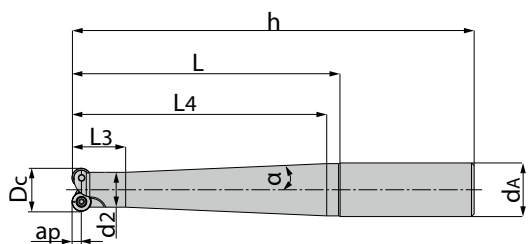

Dimension in mm										Ordering code	Availability		Spare parts	
Dc	dA	d2	L	h	ap	z	α	L3	L4					
15	16	13	60	108	3.5	2	2°	20	55	BEA00 RD07.015 Z02 108	●	RD.. 07	AP13-25045 5118117 MA = 2Nm	IP7 5118123
15	20	13	80	130	3.5	2	3.4°	20	75	BEA00 RD07.015 Z02 130	●	RD.. 07		
15	20	13	100	150	3.5	2	2.5°	20	95	BEA00 RD07.015 Z02 150	●	RD.. 07		
15	25	13	120	176	3.5	2	3.5°	20	115	BEA00 RD07.015 Z02 176	●	RD.. 07		
16	16	13	60	108	3.5	2	2°	20	55	BEA00 RD07.016 Z02 108	●	RD.. 07		
16	20	13	80	130	3	2	3.4°	20	75	BEA00 RD07.016 Z02 130	●	RD.. 07		
16	20	13	100	150	3.5	2	2.5°	20	95	BEA00 RD07.016 Z02 150	●	RD.. 07		
16	25	13	120	176	3.5	2	3.5°	20	115	BEA00 RD07.016 Z02 176	●	RD.. 07		
20	20	18	40	90	5	2	2.9°	20	35	BEA00 RD10.020 Z02 090	●	RD.. 10	AP13-35072 5118118 MA = 3.5Nm	IP15 5088520
20	20	18	60	110	5	2	1.3°	20	55	BEA00 RD10.020 Z02 110	●	RD.. 10		
20	25	18	80	136	5	2	3.4°	20	75	BEA00 RD10.020 Z02 136	●	RD.. 10		
20	25	18	100	156	5	2	2.5°	20	95	BEA00 RD10.020 Z02 156	●	RD.. 10		
20	25	18	120	176	5	2	2°	20	115	BEA00 RD10.020 Z02 176	●	RD.. 10		

Order example: 1 piece BEA00 RD07.015 Z02 108

End milling cutter form B / metric

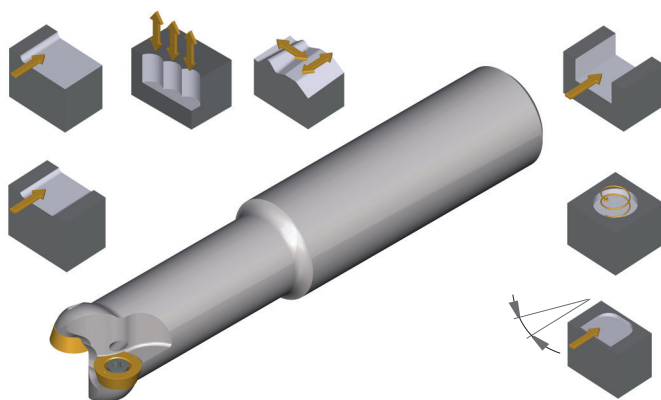
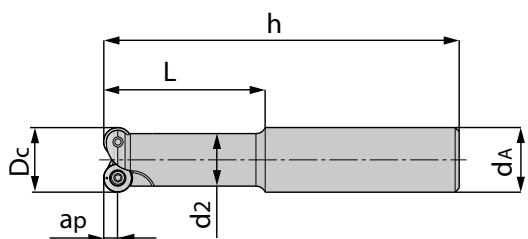





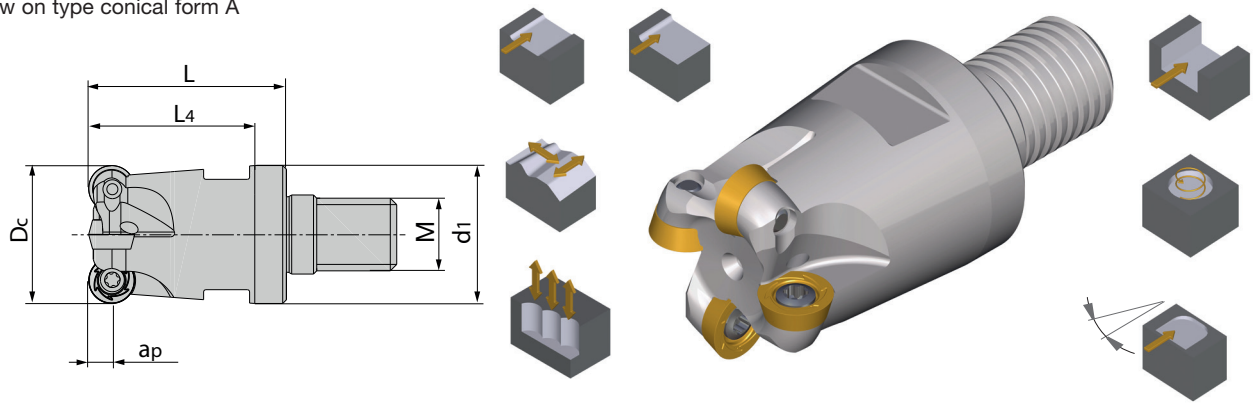

Dimension in mm							Ordering code	Availability		Spare parts	
Dc	dA	d2	L	h	ap	z					
15	16	13	40	88	3.5	2	BEB00 RD07.015 Z02 088	●	RD.. 07	AP13-25045 5118117 MA = 2Nm	IP7 5118123
16	16	13	40	88	3.5	2	BEB00 RD07.016 Z02 088	●	RD.. 07		

Order example: 1 piece BEB00 RD07.015 Z02 088

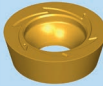
● Available from stock
○ On request

Screw on type conical form A



Dimension in mm							Ordering code	Availability		Spare parts		
Dc	d1	L	L4	ap	z	M						
10	13	23	17	2.5	2	8	BSA00 RD05.010 Z02 M8	●	RD.. 05..	AP13-18037 5118116 MA = 0.5Nm	IP6 5126412	-
12	13	23	17	2.5	3	8	BSA00 RD05.012 Z03 M8	●				
30	29	43	38	3.5	5	16	BSA00 RD07.030 Z05 M16	●	RD.. 07..	AP13-25045 5118117 MA = 2Nm	IP7 5118123	-
30	29	43	38	5	4	16	BSA00 RD10.030 Z04 M16	●	RD.. 10..	AP13-35072 5118118 MA = 3.5Nm	IP15 5088520	-
32	29	43	38	5	4	16	BSA00 RD10.032 Z04 M16	●				
32	29	43	38	6	3	16	BSA00 RD12.032 Z03 M16	●	RD.. 12..	A13-35086 5118120 MA = 3.5Nm	IP15 5088520	 Clamping screw RD12 5125841
32	29	43	38	8	2	16	BSA00 RD16.032 Z02 M16	●	RD.. 16..	AP13-45105 5118121 MA = 5Nm	IP15 5088520	 +  Clamping system : Clamp 5125842 Clamping screw 5118121

Order example: 1 piece BSA00 RD05.010 Z02 M8

Screw on type cylindrical form B

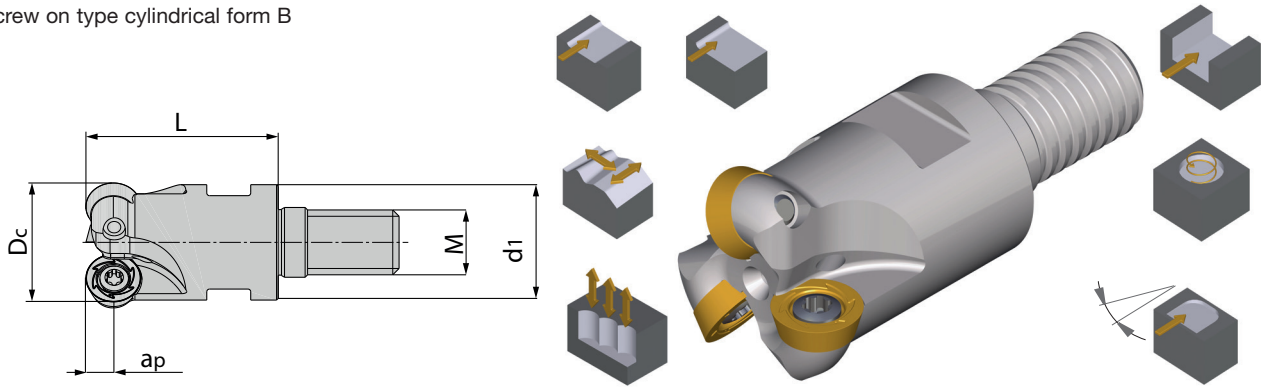

Dimension in mm						Ordering code	Availability		Spare parts		
Dc	d1	L	ap	z	M						
15	13	23	2.5	4	8	BSB00 RD05.015 Z04 M8	●	RD.. 05..	AP13-18037 5118116 $M_A = 0.5Nm$	IP6 5126412	-
16	13	23	2.5	4	8	BSB00 RD05.016 Z04 M8	●				
20	18	30	2.5	5	10	BSB00 RD05.020 Z05 M10	●				
25	21	35	2.5	6	12	BSB00 RD05.025 Z06 M12	●				
15	13	23	3.5	2	8	BSB00 RD07.015 Z02 M8	●	RD.. 07..	AP13-25045 5118117 $M_A = 2Nm$	IP7 5118123	-
15	13	23	3.5	3	8	BSB00 RD07.015 Z03 M8	●				
16	13	23	3.5	2	8	BSB00 RD07.016 Z02 M8	●				
16	13	23	3.5	3	8	BSB00 RD07.016 Z03 M8	●				
20	18	30	3.5	4	10	BSB00 RD07.020 Z04 M10	●				
25	21	35	3.5	5	12	BSB00 RD07.025 Z05 M12	●				
32	29	43	3.5	6	16	BSB00 RD07.032 Z06 M16	●				
35	29	43	3.5	6	16	BSB00 RD07.035 Z06 M16	●				
20	18	30	5	2	10	BSB00 RD10.020 Z02 M10	●	RD.. 10..	AP13-35072 5118118 $M_A = 3.5Nm$	IP15 5088520	-
25	21	35	5	3	12	BSB00 RD10.025 Z03 M12	●				
35	29	43	5	4	16	BSB00 RD10.035 Z04 M16	●				
35	29	43	5	5	16	BSB00 RD10.035 Z05 M16	●				
40	29	43	5	5	16	BSB00 RD10.040 Z05 M16	●				
42	29	43	5	5	16	BSB00 RD10.042 Z05 M16	●				
42	29	43	5	6	16	BSB00 RD10.042 Z06 M16	●				
25	21	35	6	2	12	BSB00 RD12.025 Z02 M12	●	RD.. 12..	AP13-35086 5118120 $M_A = 3.5Nm$	IP15 5088520	 Clamping screw RD12 5125841
35	29	43	6	3	16	BSB00 RD12.035 Z03 M16	●				
40	29	43	6	2	16	BSB00 RD12.040 Z04 M16	●				
42	29	43	6	4	16	BSB00 RD12.042 Z04 M16	●				
40	29	43	8	2	16	BSB00 RD16.040 Z02 M16	●	RD.. 16	AP13-45105 5118121 $M_A = 5Nm$	IP15 5088520	 Clamping system : Clamp 5125842 Clamping screw 5118121

Order example: 1 piece BSB00 RD05.015 Z04 M8

N = Number of cutting edges	Ordering code	d	s	d ₁	Cutting materials Ident No.													
					BCP20M	BCP25M	BCP30M	BCP35M	BCP40M	BCM35M	BCM40M	BCK15M	BCK20M	BCH03M	BCH05M	BCH10M	BCH30M	
	RDHT 12T3 MO-MM	12	3.97	4.40							●	●						
	RDKT 12T3 MOS-MP	12	3.97	3.90	●	●	●	●										
	RDKT 12T3 MOS-MM	12	3.97	3.90							●	●						
	RDKT 1604 MOS-MP	16	4.76	5.2	●	●	●	●										
	RDKT 1604 MOS-MM	16	4.76	5.2							●	●						
	RDHW 0501 MOS-FH	5	1.50	2.2												●		
	RDKW 0501 MOS-MH	5	1.50	2.2													●	●
	RDKW 0501 MOS-MP	5	1.50	2.2	●	●												
	RDKW 0501 MOS-MM	5	1.50	2.2						●	●							
	RDKW 0501 MOS-MK	5	1.50	2.2								●	●					
	RDKW 0501 MOS-RH	5	1.50	2.2														●
	RDHW 0702 MOS-FH	7	2.38	2.7													●	
	RDKW 0702 MOS-MH	7	2.38	2.7													●	●
	RDKW 0702 MOS-MP	7	2.38	2.7	●	●	●	●										
	RDKW 0702 MOS-MM	7	2.38	2.7							●	●						
	RDKW 0702 MOS-MK	7	2.38	2.7									●	●				
	RDKW 0702 MOS-RH	7	2.38	2.7														●
	RDHW 1003 MOS-FH	10	3.18	3.9													●	
	RDKW 1003 MOS-MH	10	3.18	3.9													●	●
	RDKW 1003 MOS-MP	10	3.18	3.9	●	●	●	●										
	RDKW 1003 MOS-MM	10	3.18	3.9							●	●						
	RDKW 1003 MOS-MK	10	3.18	3.9									●	●				
	RDKW 1003 MOS-RH	10	3.18	3.9														●
	RDKW 12T3 MOS-MH	12	3.97	3.9													●	●
	RDKW 12T3 MOS-MP	12	3.97	3.9	●	●	●	●										
RDKW 12T3 MOS-MK	12	3.97	3.9									●	●					
RDKW 12T3 MOS-RH	12	3.97	3.9														●	
RDKW 1604 MOS-MH	16	4.76	5.2													●	●	
RDKW 1604 MOS-MP	16	4.76	5.2	●	●	●	●											
RDKW 1604 MOS-MK	16	4.76	5.2									●	●					
RDKW 1604 MOS-RH	16	4.76	5.2														●	

Order example: 10 pieces RDHT 12T3 MO-MM BCM35M

Ø 16 mm - 25 mm
Screw on type
Insert size 06

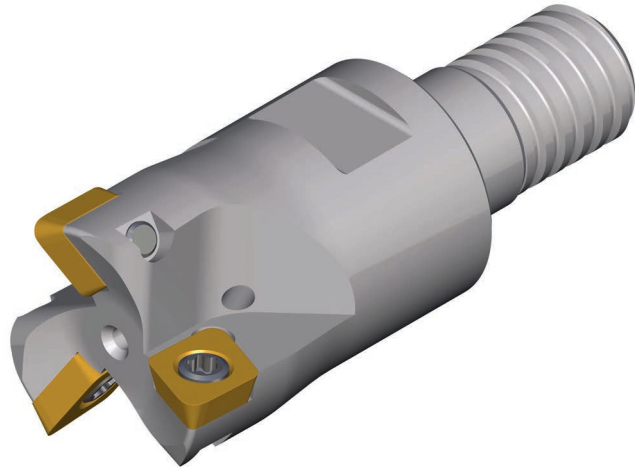
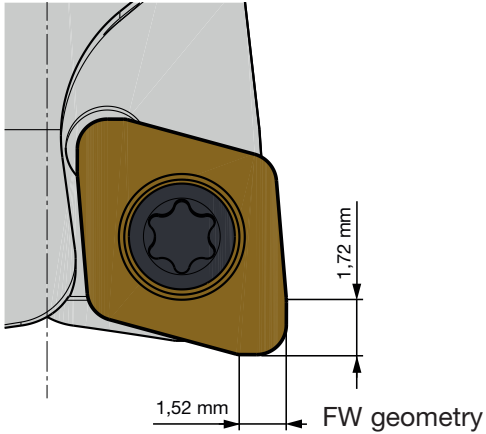

Special features:

- Universal applicable finishing tool for all current materials and applications
- Especially wear resistant and exact produced inserts
- Axial & radial wiper geometry FW for high productivity (bigger ap & fz possible)
- Vibration free finishing, also with big depths.

CD.. 06..

Insert geometry	Cutting depth [mm] ap max	Feed [mm] fz
FH	0.10 0.25 1.00	0.08 0.22 0.33
FW	0.12 0.25 1.80	0.10 0.25 0.40

Screw on type 95° / metric

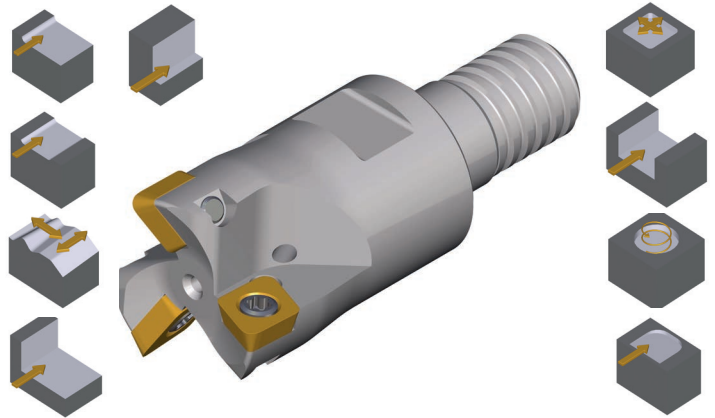
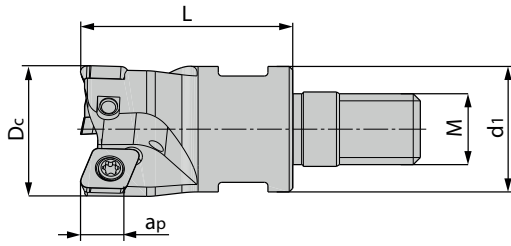

Dimension in mm						Ordering code	Availability		Spare parts	
Dc	d1	L	ap	z	M					
16	12.7	23	6	2	M08	BS95 CD06.016 Z02 M08	●	CDGX 06..	AP17-25055 5085710 MA = 2Nm	IP7 5118123
16	12.7	23	6	2	M10	BS95 CD06.016 Z02 M10	●			
20	17.7	30	6	3	M10	BS95 CD06.020 Z03 M10	●			
25	20.7	35	6	3	M12	BS95 CD06.025 Z03 M12	●			
25	20.7	35	6	4	M12	BS95 CD06.025 Z04 M12	●			
35	28.7	43	6	5	M16	BS95 CD06.035 Z05 M16	●			
42	28.7	43	6	6	M16	BS95 CD06.042 Z06 M16	●			

Order example: 1 Piece BS95 CD06.016 Z02 M08

Inserts

N = Number of cutting edges	Ordering code	l	d	s	d1	R	BCM35M	BCM40M	BCK15M	BCK20M	BCH03M	BCH05M	BCH10M	BCH23M	BCH30M
	CDGX 060210-SR-FH	5.8	6.5	2.38	2.9	1					●		●	●	●
	CDGX 060210-SR-FW	1.72	6.5	2.38	2.9	1					●		●		

Order example: 10 pieces CDGX 060210 SR-FH BCH03M

Ø 8 mm - 25 mm

End Milling Cutter Steel Shank

Insert size 08 to 25

Ø 8 mm - 32 mm

End Milling Cutter Solid Carbide Shank

Insert size 08 to 32

Ø 8 mm - 32 mm

Screw on type Steel Shank

Insert size 08 to 32

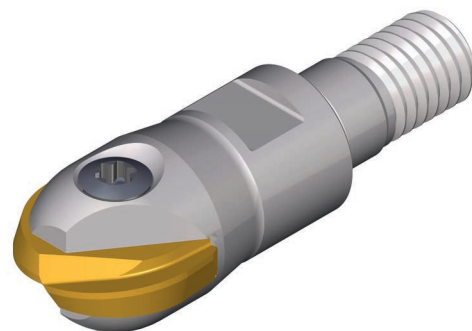
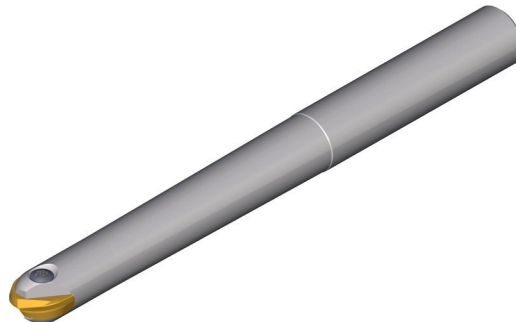
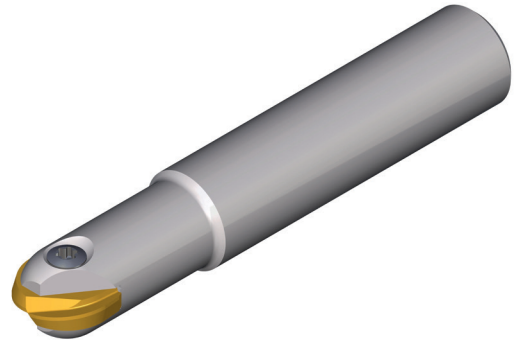

Special features: Milling HFC

- Ball nose copying tool for semi finishing and finishing
- Wide variety of inserts and tools
- Vibrations reducing, soldered solid carbide tools for finishing of high quality surfaces
- Specific rotation tolerances
- Application of ultrafine grain carbides for high wear resistance and at the same time high fracture resistance – for more process security

BE 08

"Insert geometry"	"Cutting depth [mm] ap max" BE 08	"Feed [mm] fz" BE 08
MHN	0.10 0.15 0.20	0.10 0.15 0.20
SHN	0.10 0.12 0.15	0.08 0.12 0.15

BE 10

"Insert geometry"	"Cutting depth [mm] ap max" BE 010	"Feed [mm] fz" BE 10
MHN	0.12 0.20 0.24	0.15 0.20 0.25
SHN	0.10 0.15 0.20	0.10 0.15 0.20

BE 12

"Insert geometry"	"Cutting depth [mm] ap max" BE 12	"Feed [mm] fz" BE 12
FHF	0.06 0.12 0.18	0.08 0.14 0.20
MHF	0,10 0.15 0,24	0,15 0.22 0,30
SHF	0.15 0.25 0.30	0.15 0.25 0.30
MHN	0.15 0.30 0.40	0.15 0.25 0.35
SHN	0.10 0.16 0.22	0.10 0.16 0.22

BE 16

"Insert geometry"	"Cutting depth [mm] ap max" BE 16	"Feed [mm] fz" BE 16
FHF	0.08 0.15 0.22	0.12 0.18 0.24
MHF	0,13 0,20 0,32	0,18 0,25 0,30
SHF	0.20 0.30 0.35	0.20 0.30 0.35
MHN	0.20 0.35 0.45	0.20 0.30 0.35
SHN	0.12 0.18 0.24	0.14 0.20 0.26

BE 20

"Insert geometry"	"Cutting depth [mm] ap max" BE 20	"Feed [mm] fz" BE 20
FHF	0.12 0.20 0.28	0.18 0.24 0.30
MHF	0,20 0.25 0,40	0,22 0.30 0,38
SHF	0.20 0.35 0.45	0.30 0.40 0.45
MHN	0.25 0.40 0.50	0.30 0.40 0.45
SHN	0.16 0.24 0.32	0.20 0.28 0.36

BE 25

"Insert geometry"	"Cutting depth [mm] ap max" BE 25	"Feed [mm] fz" BE 25
FHF	0.17 0.25 0.33	0.17 0.25 0.32
MHF	0,25 0.31 0,50	0,22 0,32 0,42
SHF	0.25 0.40 0.50	0.30 0.40 0.45
MHN	0.30 0.45 0.55	0.30 0.40 0.45
SHN	0.22 0.30 0.38	0.20 0.30 0.40

BE 32

"Insert geometry"	"Cutting depth [mm] ap max" BE 32	"Feed [mm] fz" BE 32
FHF	0.22 0.30 0.38	0.22 0.30 0.38
MHF	0,32 0.40 0,64	0,25 0.35 0,45
SHF	0.30 0.45 0.55	0.40 0.50 0.55
MHN	0.35 0.50 0.60	0.40 0.50 0.55
SHN	0.25 0.35 0.45	0.25 0.35 0.45

End milling cutter form A / metric

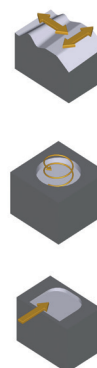
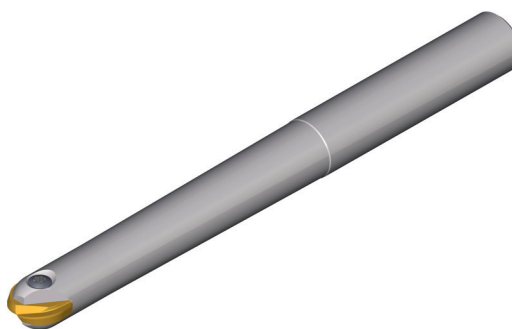
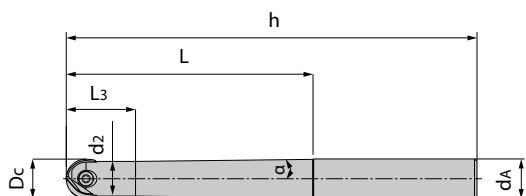



Dimension in mm								Ordering code	Availability		Spare parts	
Dc	dA	d2	h	α	L	L3	z					
8	12	6,5	110	3°30'	53	18,5	2	BEA00 BE08.008.Z02 110 NC	●	BE08..	AP12-25063	IP7 5118123
8	12	6,5	132	2°	75	18,5	2	BEA00 BE08.008.Z02 132 NC	●		5118702 $M_A = 2Nm$	
10	12	8	110	2°20'	53	21	2	BEA00 BE10.010 Z02 110 NC	●	BE10..	AP12-30077	IP8 5088519
10	12	8	132	1°15'	75	21	2	BEA00 BE10.010 Z02 132 NC	●		5118703 $M_A = 2Nm$	
12	12	10	110	1°20'	53	22	2	BEA00 BE12.012 Z02 110 NC	●	BE12..	AP12-35095	IP10 5118726
12	12	10	145	0°40'	85	22	2	BEA00 BE12.012 Z02 145 NC	●		5118704 $M_A = 3,5Nm$	
16	16	14	123	1°15'	63	28	2	BEA00 BE16.016 Z02 123 NC	●	BE16..	AP12-40133	IP15 5088520
16	16	14	166	0°40'	100	28	2	BEA00 BE16.016 Z02 166 NC	●		5118705 $M_A = 4Nm$	
20	20	17	141	2°	75	34	2	BEA00 BE20.020 Z02 141 NC	●	BE20..	AP12-50162	IP20 5088521
20	20	17	191	1°	115	34	2	BEA00 BE20.020 Z02 191 NC	●		5118706 $M_A = 5Nm$	
25	25	21	166	2°	90	41	2	BEA00 BE25.025 Z02 166 NC	●	BE25..	AP12-60200	IP25 5118727
25	25	21	215	3°	135	41	2	BEA00 BE25.025 Z02 215 NC	●		5118707 $M_A = 6Nm$	

Order example: 1 piece BEA00 BE08.008.Z02 110 NC

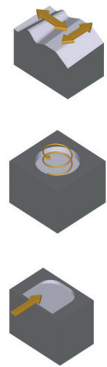
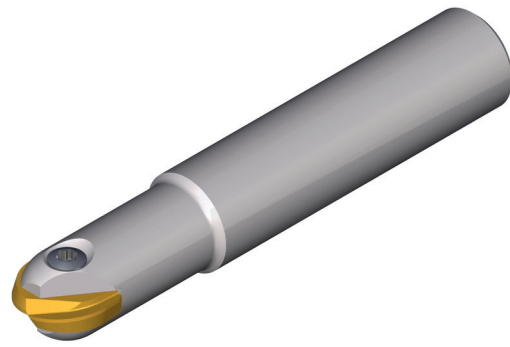
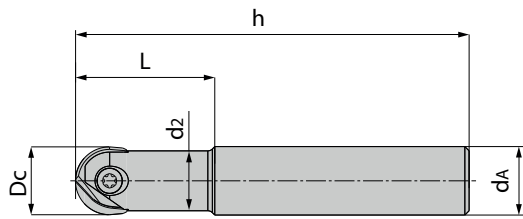
End milling cutter form B / metric





Dimension in mm						Ordering code	Availability		Spare parts	
Dc	da	d2	h	L	z					
8	12	7	92	32	2	BEB00 BE08.008 Z02 092	●	BE08..	AP12-25063 5118702 MA = 2Nm	IP7 5118123
10	12	9	92	32	2	BEB00 BE10.010 Z02 092	●	BE10..	AP12-30077 5118703 MA = 2Nm	IP8 5088519
12	12	11	92	32	2	BEB00 BE12.012 Z02 092	●	BE12..	AP12-35095 5118704 MA = 3,5Nm	IP10 5118726
12	12	11	145	45	2	BEB00 BE12.012 Z02 145 NC	●			
16	16	14,5	92	32	2	BEB00 BE16.016 Z02 092	●	BE16..	AP12-40133 5118705 MA = 4Nm	IP15 5088520
16	16	14,5	160	55	2	BEB00 BE16.016 Z02 160 NC	●			
20	20	18	104	38	2	BEB00 BE20.020 Z02 104	●	BE20..	AP12-50162 5118706 MA = 5Nm	IP20 5088521
20	20	18	190	65	2	BEB00 BE20.020 Z02 190 NC	●			
25	25	22,5	121	45	2	BEB00 BE25.025 Z02 121	●	BE25..	AP12-60200 5118707 MA = 6Nm	IP25 5118727
25	25	22,5	210	75	2	BEB00 BE25.025 Z02 210 NC	●			

Order example: 1 piece BEB00 BE08.008 Z02 092

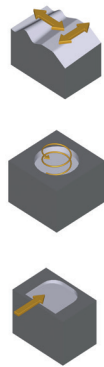
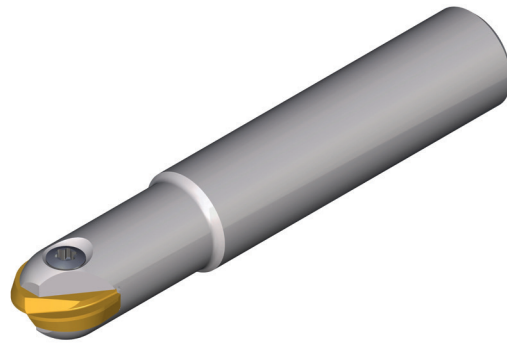
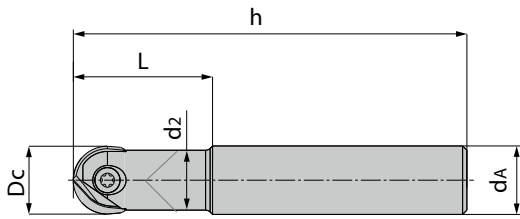
End milling cutter form B Solid carbide shank / metric





Dimension in mm						Ordering code	Availability		Spare parts	
Dc	dA	d2	h	L	z					
8	8	7	80	25	2	CEB00 BE08.008 Z02 80	●	BE08..	AP12-25063 5118702 MA = 2Nm	IP7 5118123
8	8	7	100	25	2	CEB00 BE08.008 Z02 100	●			
8	8	7	150	40	2	CEB00 BE08.008 Z02 150	○			
10	10	8,8	80	35	2	CEB00 BE10.010 Z02 80	○	BE10..	AP12-30077 5118703 MA = 2Nm	IP8 5088519
10	10	8,8	120	35	2	CEB00 BE10.010 Z02 120	●			
10	10	8,8	150	50	2	CEB00 BE10.010 Z02 150	●			
12	12	10,5	80	35	2	CEB00 BE12.012 Z02 80	●	BE12..	AP12-35095 5118704 MA = 3,5Nm	IP10 5118726
12	12	10,5	120	35	2	CEB00 BE12.012 Z02 120	●			
12	12	10,5	160	50	2	CEB00 BE12.012 Z02 160	●			
16	16	14	100	40	2	CEB00 BE16.016 Z02 100	●	BE16..	AP12-40133 5118705 MA = 4Nm	IP15 5088520
16	16	14	140	40	2	CEB00 BE16.016 Z02 140	●			
16	16	14	175	55	2	CEB00 BE16.016 Z02 175	●			
20	20	18	100	50	2	CEB00 BE20.020 Z02 100	○	BE20..	AP12-50162 5118706 MA = 5Nm	IP20 5088521
20	20	18	140	50	2	CEB00 BE20.020 Z02 140	●			
20	20	18	190	75	2	CEB00 BE20.020 Z02 190	●			
25	25	22,4	160	60	2	CEB00 BE25.025 Z02 160	○	BE25..	AP12-60200 5118707 MA = 6Nm	IP25 5118727
25	25	22,4	210	90	2	CEB00 BE25.025 Z02 210	●			
32	32	28,6	190	65	2	CEB00 BE32.032 Z02 190	○	BE32..	AP12-80250 5118709 MA = 8Nm	IP40 5118728
32	32	28,6	240	105	2	CEB00 BE32.032 Z02 240	○			

Order example: 1 piece CEB00 BE08.008 Z02 080

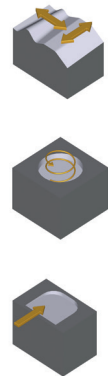
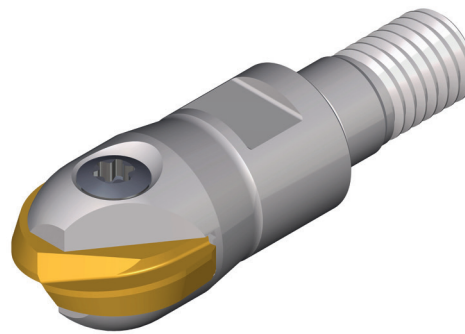
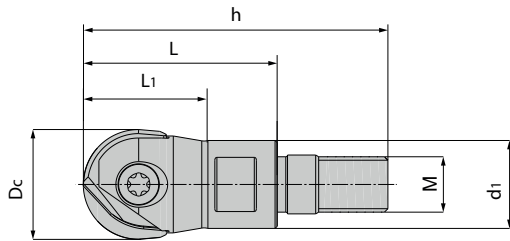
Screw on type / metric



Dimension in mm							Ordering code	Availability		Spare parts	
Dc	da	h	L	L1	M	z					
8	9.7	36.5	23	16	6	2	BS00 BE08.008 Z02 M06	●	BE08..	AP12-25063 5118702 M _A = 2Nm	IP7 5118123
10	9.7	36.5	23	23	6	2	BS00 BE10.010 Z02 M06	●	BE10..	AP12-30077 5118703 M _A = 2Nm	IP8 5088519
12	9.7	36.5	23	23	6	2	BS00 BE12.012 Z02 M06	●	BE12..	AP12-35095 5118704 M _A = 3.5Nm	IP10 5118726
12	12.7	44.0	28	19	8	2	BS00 BE12.012 Z02 M08	●			
16	12.7	44.0	28	28	8	2	BS00 BE16.016 Z02 M08	●	BE16..	AP12-40133 5118705 M _A = 4Nm	IP15 5088520
16	15.4	46.0	28	28	10	2	BS00 BE16.016 Z02 M10	●			
20	17.7	46.0	28	28	10	2	BS00 BE20.020 Z02 M10	●	BE20..	AP12-50162 5118706 M _A = 5Nm	IP20 5088521
25	20.7	55.0	35	35	12	2	BS00 BE25.025 Z02 M12	●	BE25..	AP12-60200 5118707 M _A = 6Nm	IP25 5118727
32	28.7	65.0	43	35	16	2	BS00 BE32.032 Z02 M16	●	BE32..	AP12-80250 5118709 M _A = 8Nm	IP40 5118728

Order example: 1 piece BS00 BE08.008 Z02 M06
Cutting data recommendations page 102-103

● Available from stock
○ On request

Description Insert Balltec

FHF = Finishing **H**ard **F**ine

MHF = Medium **H**ard **F**ine

SHF = Semifinishing **H**ard **F**ine

FHN2 = Medium **H**ard **N**eutral 2

MHN = Medium **H**ard **N**eutral

MHN2 = Medium **H**ard **N**eutral 2

SHN = Semifinishing **H**ard **N**eutral

SHN2 = Semifinishing **H**ard **N**eutral 2

Colours and execution of the original indexable inserts, may deviate from the illustration!

● Available from stock
○ On request

							Cutting materials			
N = Number of cutting edges	Ordering code	l	d	s	d ₁	r	BCH03M	BCH10M	BCH23M	BCH30M
							<p>N = 2</p>	BE12-FHF		12
BE12-SHF		12	2.99	3.5				●		
BE12-MHF		12	2.99	3.5						●
BE16-FHF		16	3.99	4		●				
BE16-SHF		16	3.99	4				●		
BE16-MHF		16	3.99	4						●
BE20-FHF		20	4.99	5		●				
BE20-SHF		20	4.99	5				●		
BE20-MHF		20	4.99	5						●
BE25-SHF		25	5.99	6				●		
BE25-MHF		25	5.99	6						●
BE32-SHF		32	6.99	8					●	
BE32-MHF		32	6.99	8						●
<p>N = 2</p>	BE08-MHN		8	2.39	2.5				●	
	BE10-MHN		10	2.59	3			●		●
	BE12-SHN		12	2.99	3.5		●			
	BE12-MHN		12	2.99	3.5			●		●
	BE16-SHN		16	3.99	4		●			
	BE16-MHN		16	3.99	4			●		●
	BE20-SHN		20	4.99	5		●			
	BE20-MHN		20	4.99	5			●		●
	BE25-MHN		25	5.99	6			●		●
	BE32-MHN		32	6.99	8			●		●
<p>N = 2</p>	BE08-MHN2		8	2.39	2.5			●		●
	BE08-SHN2		8	2.39	2.5				●	
	BE10-MHN2		10	2.59	3			●		●
	BE10-SHN2		10	2.59	3				●	
	BE12-FHN2		12	2.99	3.5		●			
	BE12-MHN2		12	2.99	3.5			●		●
	BE12-SHN2		12	2.99	3.5				●	
	BE16-FHN2		16	3.99	4		●			
	BE16-MHN2		16	3.99	4			●		●
	BE16-SHN2		16	3.99	4				●	
	BE20-FHN2		20	4.99	5		●			
	BE20-MHN2		20	4.99	5			●		●
	BE20-SHN2		20	4.99	5				●	
	BE25-MHN2		25	5.99	6			●		●
BE25-SHN2		25	5.99	6				●		

Order example: 10 pieces BE12FHF BCH03M
Description of grades page 114

● Available from stock
○ On request

Material group	Insert grade				BCP20M P20	BCP25M P25	BCP30M P30	BCP35M P35	BCP40M P40
	ISO Code		Dry machining	Wet machining					
	Material								
P	Structural steel		●	○	200-320	200-300	170-280	170-260	
	Heat treated steel		●	○	180-290	180-280	160-260	150-240	
M	Tool steel		●	○	160-260	160-250	140-230	140-220	
	Heat treated steel	1400N/mm ² high strength	●	○	130-200	130-180	120-180		
K	Stainless steel	austenitic	●	○		120-200		100-170	
		austenitic hardened	●	○		80-150			
K	Grey cast iron		●	○		180-360			
N	Nodular graphite cast iron		●	○		140-220			
N	Aluminium		●	○					
S	Copper and copper alloys		●	○					
S	Heat resistant alloys		○	●					
S	Titanium alloys		○	●					
H	Chilled cast iron	Hardness 300-600 HB	●	○					
	Hardened steel	45-52 HRC	●	○					
H	Hardened steel	53-58 HRC	●	○					
H	Hardened steel	59-63 HRC	●	○					

● recommended application
○ alternative application reduced by 30 - 50 % reduced

BCM35M M35	BCM40M M40	BCK15M K15	BCK20M K20	BCN10M N10	BCN15M N15	BWN10M N10	BCS35M S35	BCH03M	BCH05M	BCH10M	BCH23M	BCH30M
								250-400	200-320	200-320		180-280
								200-350	180-290	180-290		160-250
								180-300	160-260	160-260		140-220
								150-250	130-200	130-200		110-170
150-220	130-180							150-200				120-180
120-170	100-150							120-180				100-160
		220-400	200-360									
		180-230	170-220									
30-90												
30-90												
								60-140	50-120	50-120	60-140	
								90-260	80-240	80-240	90-260	90-180
								70-220	60-200	60-200	70-220	70-160
								60-140	50-120	50-120	50-140	-

ph HORN ph

boehlerit

Full-range innovations



Extensions

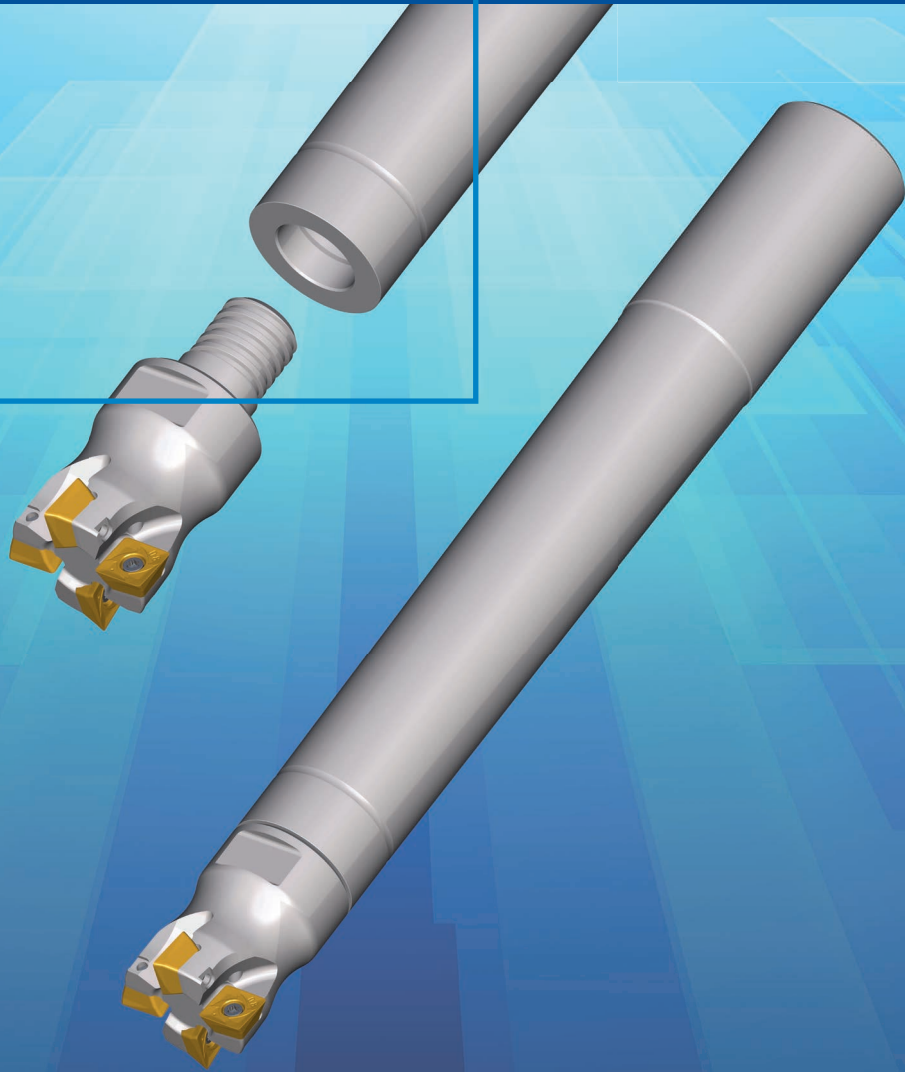

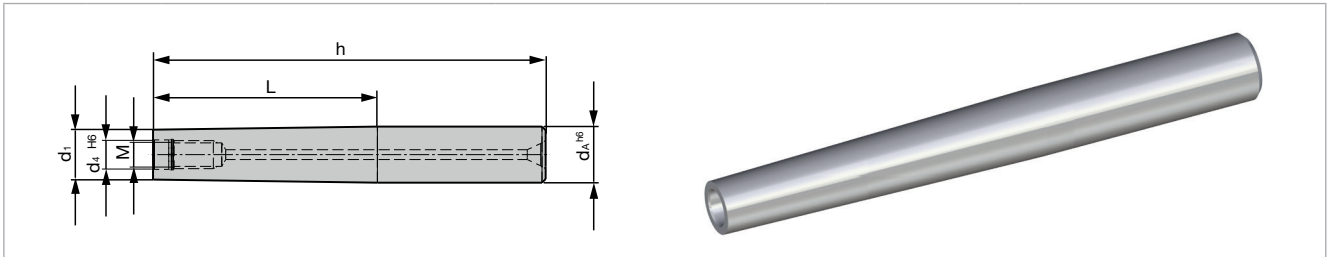

M	d ₄ ^{H6}	d ₁	d _A ^{h6}	L	h	Material-No.	Ordering code
6	6.5	9.5	10	60	20	5127650	Z 10.060 M6
6	6.5	9.5	10	80	40	5127652	Z 10.080 M6
6	6.5	9.5	10	100	60	5127653	Z 10.100 M6
6	6.5	9.5	10	120	80	5127655	Z 10.120 M6

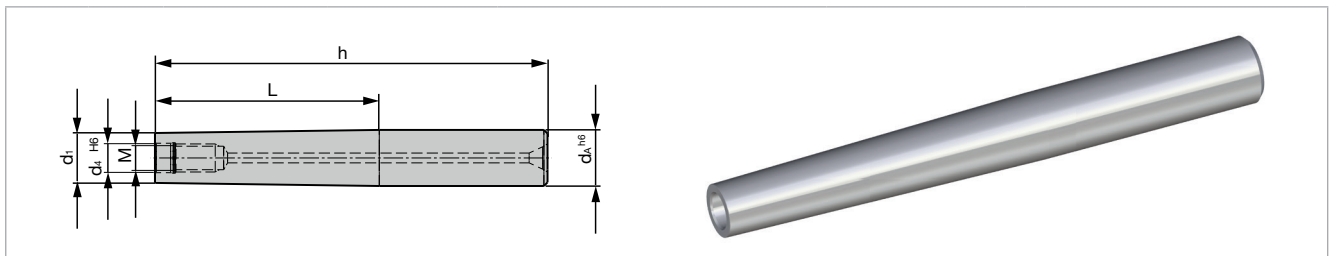

M	d ₄ ^{H6}	d ₁	d _A ^{h6}	L	h	Material-No.	Ordering code
8	8.5	12.8	16	40	95	5087764	K 16.040 M8
8	8.5	12.8	16	60	115	5088441	K 16.060 M8
8	8.5	12.8	16	80	135	5088442	K 16.080 M8
8	8.5	12.8	16	100	155	5088459	K 16.100 M8
8	8.5	12.8	16	120	175	5088462	K 16.120 M8

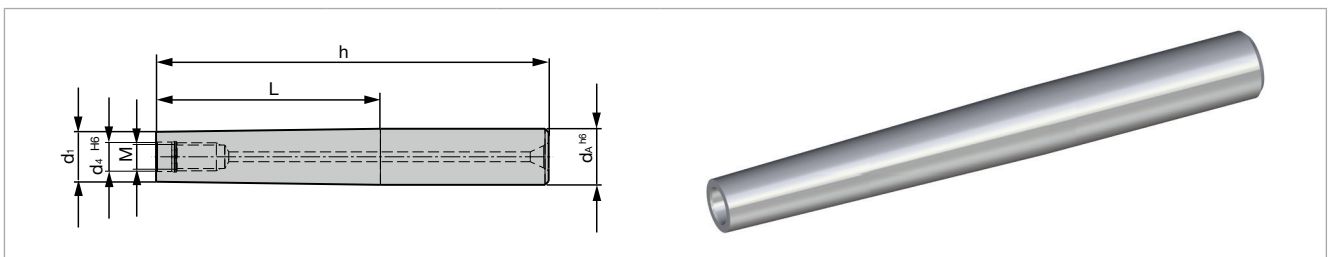

M	d ₄ ^{H6}	d ₁	d _A ^{h6}	L	h	Material-No.	Ordering code
10	10.5	17.8	20	40	100	5088552	K 20.040 M10
10	10.5	17.8	20	60	120	5088553	K 20.060 M10
10	10.5	17.8	20	80	140	5088661	K 20.080 M10
10	10.5	17.8	20	100	160	5088662	K 20.100 M10
10	10.5	17.8	20	120	180	5088768	K 20.120 M10

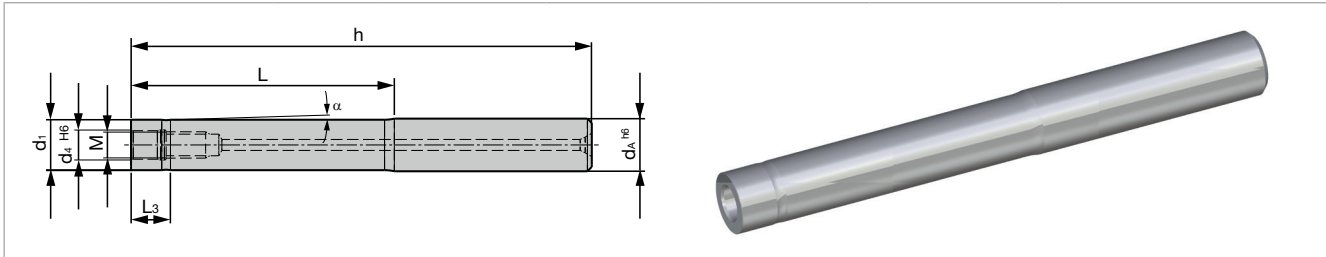

M	d ₄ ^{H6}	d ₁	d _A ^{h6}	L	h	L ₃	Material-No.	Ordering code
12	12.5	23	25	80	136	9	5088769	K 25.080 M12
12	12.5	23	25	100	156	9	5088776	K 25.100 M12
12	12.5	23	25	120	176	9	5088777	K 25.120 M12
12	12.5	23	25	140	196	9	5088779	K 25.140 M12
12	12.5	23	25	160	216	9	5088781	K 25.160 M12

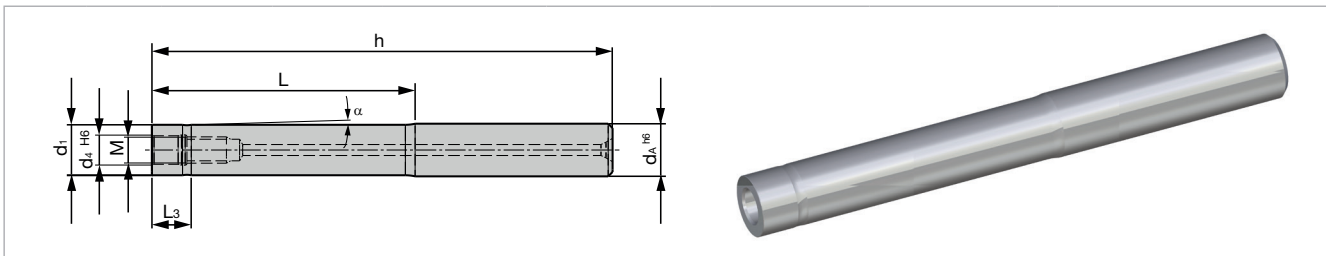

M	d ₄ ^{H6}	d ₁	d _A ^{h6}	L	h	L ₃	Material-No.	Ordering code
16	17	29	32	100	160	9	5088789	K 32.100 M16
16	17	29	32	150	210	9	5088788	K 32.150 M16
16	17	29	32	200	260	9	5088787	K 32.200 M16
16	17	29	32	250	310	9	5088786	K 32.250 M16
16	17	29	32	300	360	9	5088784	K 32.300 M16

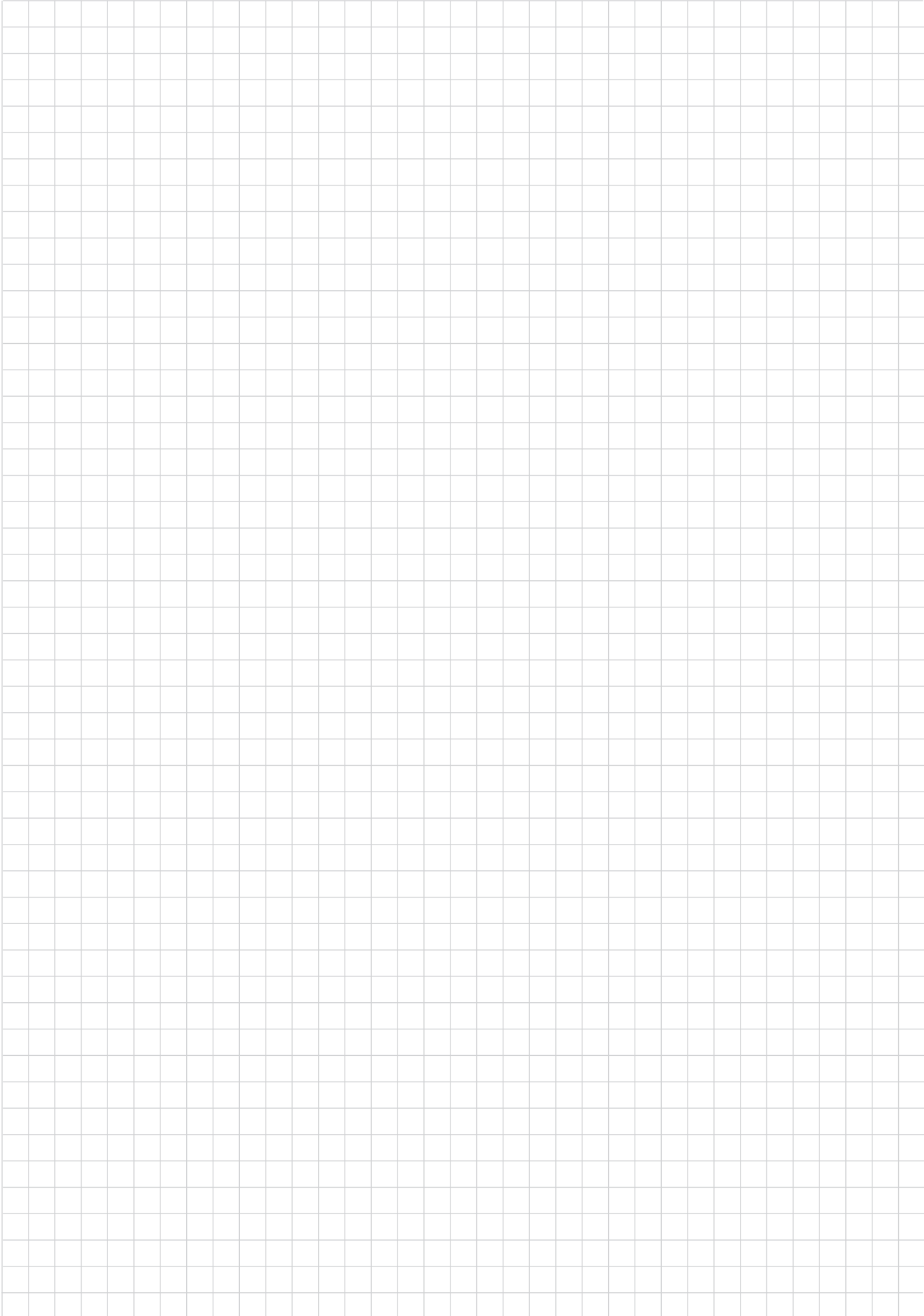

Technical hints
Attachment

Technological advantages milling







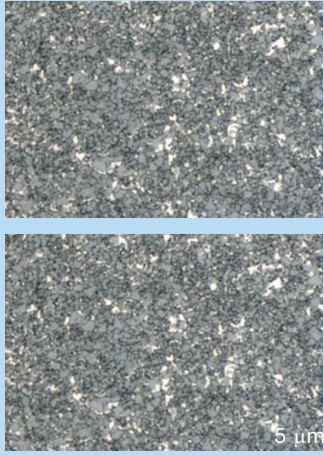
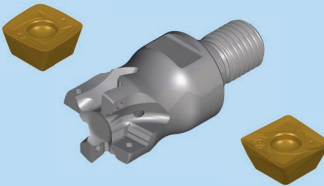
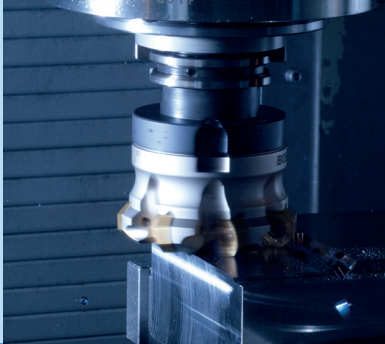
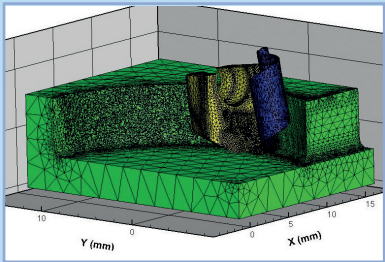
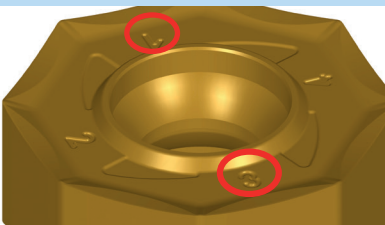

Customer benefits

<p>The biggest range of cutting grades for dealing with a very broad spread of materials enables us to ensure optimum cutting conditions.</p>		<p>High economic machining and security on a wide range of materials.</p>
<p>Patented new TERAspeed 2.0 AlTiN layer, deposited by means of HR-CVD technology (HR = High Reactivity).</p> <p>MT - CVD Nano black</p> <p>HR - CVD TERAspeed 2.0</p>		<p>The high aluminium content of this AlTiN layer and its innovative nanostructure make it possible, for the first time, to combine properties that are as such opposing – such as toughness, outstanding layer hardness and wear resistance.</p>
<p>Goldlox Thick PVD AlTiN coating. High aluminium content procures big wear resistance at higher temperatures. Coating with especial smooth surface and TiN top layer for wear recognition.</p>		<p>Increased tool life on different steels as well as simple wear recognition.</p>
<p>Raw materials Boehlerit only procures raw materials produced by qualified manufacturers from no-conflict minerals and uses them to produce cutting grades for the most exacting demands.</p>		<p>Fair partner</p>

Technological advantages milling

Customer benefits

<p>Substrates Various carbide substrates are used to produce the range of milling grades fine-tuned to cover an extensive range of applications: from roughing to finishing, from cast to stainless steel materials and aluminium, from face to step milling.</p>		<p>This is how we ensure that every customer requirement is met: be it minimal flank wear, resistance to chipping of the cutting edge, resistance to thermal cracking or crater wear</p>
<p>Multi functional tool systems</p>		<p>One carrier. Two machinings. Saving of bodies and stock costs.</p>
<p>High End Tools</p>		<p>Exact true running characteristics, all tools with internal coolant supply. Nickel implantated Improved endurance strength of the milling body due to special material and through heat treatment.</p>
<p>Dynamic FEM Design (Finite Elemente Method) technology</p>		<p>Stable tools with excellent endurance strengths characteristics and optimized chip flow</p>
<p>Size of the corner radius pressed in the insert and marking for positioning and/or numbering of cutting edges</p>		<p>Easy orientation for the operator and good true running characteristics</p>

Grade	ISO	Application range								Material group						Application				Color guide for inserts depending on coating					
		01	05	10	15	20	25	30	35	40	45	50	P	M	K	N	S	H	T		M	D	S		
										Steel	Stainless	Grey cast iron	Non-ferrous metals	High temperature materials	Hard materials	Turning	Milling	Drilling	Threading						
BCP20M	HC-P20																								
BCP25M	HC-P25																								
	HC-M25																								
	HC-K25																								
BCP30M	HC-P30																								
BCP35M	HC-P35																								
	HC-M35																								
BCP40M	HC-P40																								
	HC-M45																								
BCM35M	HC-M35																								
	HC-S30																								
BCM40M	HC-M40																								
BCK15M	HC-K15																								
BCK20M	HC-K20																								
	HC-P10																								

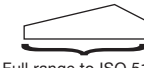
Application peak  Full range to ISO 513

Main application
 Further applications

Standard grade

Grade	ISO	Application range	Material group						Application				Color guide for inserts depending on coating
			P	M	K	N	S	H	T	M	D	S	
		01 05 10 15 20 25 30 35 40 45 50	Steel	Stainless	Grey cast iron	Non-ferrous metals	High temperature materials	Hard materials	Turning	Milling	Drilling	Threading	
BCN10M	HC-N10					■				●			
	HC-S20						□						
BCN15M	HC-N15					■				●			
BWN10M	HW-N10					■				●			
BCS35M	HC-S35							□		●			
	HC-M45			□									
BCH03M	HC-H03							■		●			
BCH05M	HC-H05							■					
	HC-P05		□							●			
	HC-K05				□								
BCH10M	HC-H10							■					
	HC-P10		□							●			
	HC-K10				□								
BCH23M	HC-H23							■		●			
BCH30M	HC-H30							■					
	HC-P20		□							●			
	HC-K20				□								

Application peak



Full range to ISO 513

■ Main application
□ Further applications

● Standard grade

- **BCP20M (HC-P20) TERA speed 2.0**

Harder alternative to the BCP25M grade, with HR-CVD; high resistance to abrasive wear. Perfectly suited for face milling of steel materials at higher cutting speed under stable conditions.

- **BCP25M (HC-P25/M25) Goldlox**

Multi purpose grade for milling unalloyed, low alloyed, high alloyed and stainless steel. The PVD coated grade is especially suitable for high cutting speeds on dry / wet machining under stable conditions.

- **BCP30M (HC-P30) TERA speed 2.0**

Universal steel milling grade especially for face milling. The very tough carbide substrate guarantees high machining security on a wide range of steel materials. A modern HR-CVD coating ensures economic dry machining on high cutting speeds.

- **BCP35M (HC-P35/M35) Goldlox**

Universal steel milling grade in combination with 90° approach angle. A PVD layer and a tough carbide grade for milling of the most usual steel qualities. Especially good suitable for dry milling at low to medium cutting speeds under difficult conditions.

- **BCP40M (HC-P40/M45) Goldlox**

A PVD-layer plus heavy duty carbide grade for roughing of mainly tool, heat-treated and case-hardened steel, as well as austenitic stainless materials

- **BCM35M (HC-M35/S35)**

Wear-resistant PVD coating, fine-grain grade for machining stainless and austenitic stainless materials; suitable for wet and dry machining.

- **BCM40M (HC-M40)**

Extremely tough, relative fine grained carbide substrate with thin, smooth PVD coating. Ideal grade for milling of austenitic stainless steels and materials from the Duplex group with low to medium cutting speeds. Also for wet machining, although minimum coolant supply is recommended.

- **BCK15M (HC-K15) TERA speed 2.0**

Selected raw materials for optimised K15 carbide substrate with a particularly hard and wear-resistant HR-CVD multi-layer coating. Ideal for dry machining of grey cast iron (GJL), spheroidal graphite cast iron (GJS), tempered cast iron and alloyed cast iron.

- **BCK20M (HC-K20/P10)**

Tough K20 substrate and a thick PVD coating for the machining of cast materials. Also suited as finishing grade for steel cutting and the machining of cold work steels of 54 HRC.

- **BCN10M (HC-N10/S20)**

Ideal grade for machining aluminium materials and other non ferrous metals. Due to the ultra-thin PVD TiAlN layer perfectly well suited for finishing stainless steels and grey cast iron.

- **BCN15M (HC-N15)**

Grade for aluminium machining with our new „TiBN“ CVD coating. The layer has not only a big layer hardness but also a smooth surface.

- **BWN10M (HW-N10)**

Uncoated grade for the machining of non ferrous metals and aluminium.

- **BCS35M (HC-S35)**

BCS35M is a grade with a well-balanced hardness-toughness-relation. Because of its special composition and treatment of the binder phase, the high-temperature hardness is increased, which recommends BCS35M especially for machining of heat-resisting materials. The special wear-resistant coating exhibits little chemical affinity towards titanium, which causes a drastic reduction of material transfer from the work-piece to the cutting edge

- **BCH03M**

Finishing of steel materials up to maximum 65 HRC, very stable environment conditions necessary
Highly wear resistant ceramic grade for application in high cutting speeds. Extremely dense, microfine and temperature resistant PVD coating.

- **BCH05M**

Grade for face and contouring operations with HFC and R insert tools of steel materials. HR-CVD coated

Wear resistant ceramic grade for a wide range of application with stable conditions. New nanostructured CVD coating with high red hardness and wear resistance.

- **BCH10M**

Grade for the machining of steel materials in the area up to maximum 58 HRC, PVD coated
Standard ceramic grade for microfine, wear resistant PVD coating.

- **BCH23M**

For finishing and semifinishing of materials up to maximum 60 HRC
Tough ultrafine carbide grade for good wear resistance and at the same time good breakage and cutting edge stability. Wear and temperature resistant PVD coating.

- **BCH30M**

Universal grade for the machining of the most current materials
Tough ceramic on carbide grade, breakage and crack resistance and at the same time good wear resistance, wide application range.
Microfine, resistant optimised PVD coating

Fixation screw

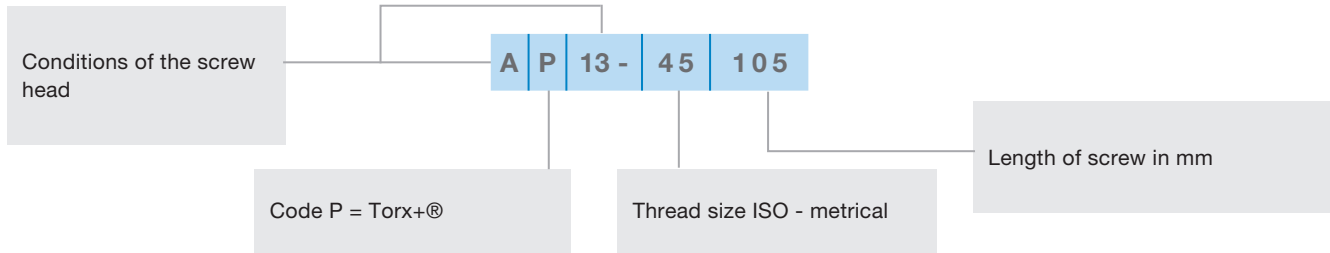

Spare parts				Milling system											
				Pitec 45N	ETAtec 45P	THETAtec 45N	ISO 45P	BETAtec 90P Feed	DELTAtec 90P Feed	DELTAtec 90N	DELTAtec 90N Tang	ISO 90P	THETAtec 88N	ZETAtec 90N	BALLtec
Designation	Ordering code	Torque® wrench	torque												
A02-30076	5084082	T9	2 Nm							•					
A02-60160	6401270	T25	6 Nm	•						•					
AP02-25051	5091691	IP8	1,5 Nm						•						
AP02-25064	5127961	IP7	1,5 Nm										•		
AP02-25068	5085706	IP8	2 Nm						•						
AP02-30083	5112357	IP9	2 Nm							•					
AP02-35100	5092669	IP15	3,5 Nm						•						
AP02-40054	5085714	IP15	3 Nm		•					•			•		
AP02-40082	5122796	IP15	3Nm		•										
AP02-40095	5085711	IP15	3 Nm								•				
AP02-50108	5112356	IP20	5 Nm							•					
A06-40115	5084080	T20	5 Nm	•		•						•			
AP06-40115	5131917	IP20	5 Nm	•		•						•			
AP12-25063	5118702	IP7	1,4 Nm										•		
AP12-30077	5118703	IP8	2,5 Nm										•		
AP12-35095	5118704	IP10	3,5 Nm										•		
AP12-40133	5118705	IP15	5,0 Nm										•		
AP12-50162	5118706	IP20	7,0 Nm										•		
AP12-60200	5118707	IP25	8,0 Nm										•		
AP12-80250	5118709	IP40	20,0 Nm										•		
AP13-18037	5118116	IP6	0,6 Nm											•	
AP13-25045	5118117	IP7	1,4 Nm											•	
AP13-35072	5118118	IP15	3,5 Nm											•	
AP13-35086	5118120	IP15	3,5 Nm											•	
AP13-40110	5084084	IP15	3 Nm							•					
AP13-45105	5118121	IP15	5,5 Nm											•	
AP13-45108	5085713	IP20	5 Nm				•								
AP17-25055	5085710	IP8	2 Nm								•				•
Clamping screw RD12	5125841	IP15	5,0 Nm											•	
Clampingsystem RD16	5125842 5118121	IP15	5,0 Nm											•	

DINA PLUS torque® wrench kit

Special features:

- self-regulating torque for each torx-size, use to special system (no self-adjustment required)
- huge range of colour-marked blades (T6 -T20 / IP6 - IP20)
- 100 % torque availability when loosening screws
- high tool life through anodised aluminium handle



Designation			Ordering code		
DINA PLUS® Kit / (1 handle +14 blades in a box)			5126413		
DINA PLUS® Handle only			On request		
Torx® blade			Torx® PLUS blade		
Size	torque Nm max	Ordering code	Size	torque Nm max.	Ordering code
T6	0.6 Nm	5126416	IP6	0.6 Nm	5126423
T7	0.9 Nm	5126417	IP7	0.9 Nm	5126425
T8	1.2 Nm	5126418	IP8	1.2 Nm	5126426
T9	1.4 Nm	5126419	IP9	1.4 Nm	5126427
T10	2.0 Nm	5126420	IP10	2.0 Nm	5126428
T15	3.0 Nm	5126421	IP15	3.0 Nm	5126429
T20	5.0 Nm	5126422	IP20	5.0 Nm	5126430
Available torques can deviate from suggested values for any system					

Spare parts		Milling system												
		PItec 45N	ETAttec 45P	THETAttec 45N	ISO 45P	BETAttec 90P Feed	DELTAtec 90P Feed	DELTAtec 90N	DELTAtec 90N Tang	ISO 90P	THETAttec 88N	ZETAttec 90N	BALLtec	ISO 00P
Designation	Ordering code													
T6	5118122													
T7	5121167													
T9	5088515						●	●						
T10	5088516													
T15	5088517	●					●			●				
T20	5088518	●		●			●							
IP6	5126412												●	
IP7	5118123											●	●	●
IP8	5088519					●				●		●		
IP9	5118124											●		
IP10	5118726											●		
IP15	5088520		●			●		●	●	●		●	●	
IP20	5088521				●							●		
IP25	5118727											●		
IP40	5118728											●		

Face Milling Cutter

Bevel angle W_1 max. for plunge milling "ramping"

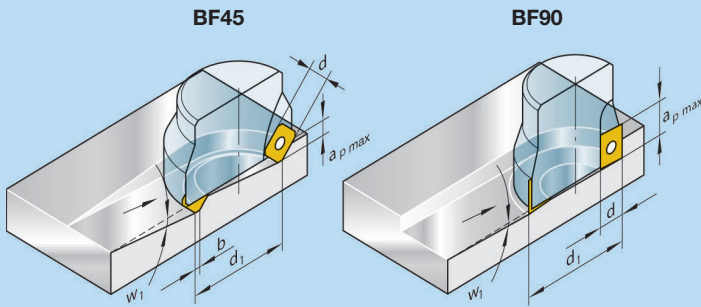

	BF45	BF90	
d	12.7	6.65	9.52
b	1.4		
$a_{p \max}$	5.5	8	14
d_1	W_1 max Degree		
mm			
40	8.5	1.0	1.5
50	6.5	0.8	1.1
63	5.0	0.6	0.8
80	3.5	0.5	0.6
100	3.0		0.5
internal cutting depth: $0.7 \times a_{p \max}$			

End milling cutter

Bevel angle W_1 max. for plunge milling "ramping"

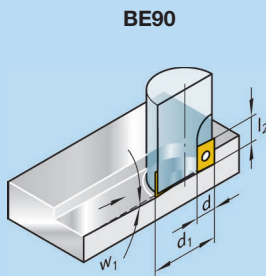

	BE90			
	d_1	l_2	d	W_1 max Degree
	16	8	6.65	3.0
	20	8	6.65	2.1
	25	8	6.65	1.5
	25	14	9.52	2.8
	32	14	9.52	2.0
	40	14	9.52	1.5

Formulas

Revolutions n (min^{-1}):

$$n = \frac{v_c \cdot 1000}{\pi \cdot d_1}$$

Feed rate

$$V_f \text{ (mm/min): } V_f = f_z \cdot Z_{\text{eff}} \cdot n$$

Chip volume-Q (cm^3/min):

$$Q = \frac{a_e \cdot a_p \cdot V_f}{1000}$$

Cutting speed

$$v_c \text{ (m/min): } v_c = \frac{n \cdot \pi \cdot d_1}{1000}$$

Feed per tooth

$$f_z \text{ (mm): } f_z = \frac{V_f}{Z_{\text{eff}} \cdot n}$$

Drive power

$$P_e \text{ (kW): } P_e = \frac{Q}{LF}$$

v_c = Cutting speed (m/min)

n = Revolution (min^{-1})

d_1 = Cutter diameter (mm)

V_f = Feed rate (mm/min)

f_z = Feed per tooth (mm)

P_e = Drive power

Z_{eff} = effective number of teeth

Q = Chip volume (cm^3/min)

a_e = Width of cut (mm)

a_p = Depth of cut (mm)

LF = Efficiency factor or ($\text{cm}^3/\text{min}/\text{kW}$)

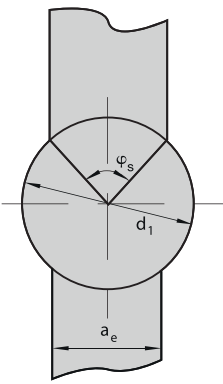
Centerline location	
$\varphi_s = 2 \cdot \sin^{-1} \left(\frac{a_e}{d_1} \right)$	

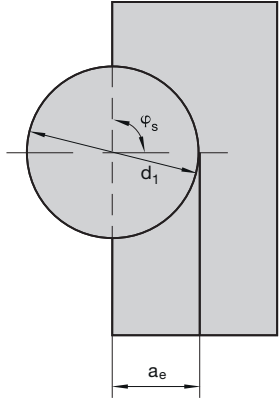
Edge milling	
$\varphi_s = \sin^{-1} \left(\frac{a_e - \frac{d_1}{2}}{\frac{d_1}{2}} \right) + 90$	

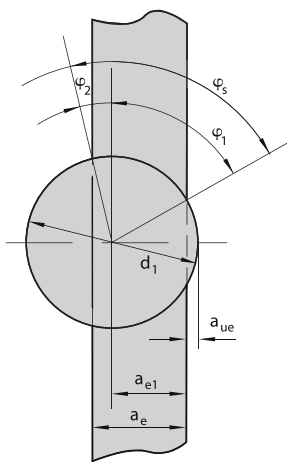
Adjusted milling	
$\sin \varphi_1 = \frac{2 \times \left(\frac{d_1}{2} - a_{ue} \right)}{d_1}$	
$\sin \varphi_2 = \frac{2 \times (a_e - a_{e1})}{d_1}$	
$\sin \varphi_s = \sin \varphi_1 + \sin \varphi_2$	

Dimensions and units	Application formulas	
a_p = Depths of cut in mm a_e = Width of cut in mm l = Machined length in mm h_m = Medium chip thickness v_c = Cutting speed in m/mm f_z = Feed per tooth in mm d_1 = External tool diameter d_e = Effective diameter with different inserts and at specified cut depth in mm d = Insert diameter in mm z = Number of tool cutting edges k = Setting angle φ_s = Approach angle	Revolutions per minute n [rpm]	Medium chip thickness h_m mm]
	$n = \frac{v_c \times 1000}{\pi \cdot d_e}$	$h_m = f_z \times \frac{a_e}{d_e}$
	Feed rate v_f [mm/min]	valid only up to $\frac{a_e}{d_e} < 0,3$ otherwise $\varphi = 60^\circ$ $h_m = \frac{360 \times f_z \times a_e \times \sin(k)}{\pi \cdot d_e \varphi_s}$
	$v_f = f_z \cdot n \cdot z$	
	Feed per revolution f [mm/rev]	Chip removal rate Q [cm ³ /min]
$f = \frac{v_f}{n}$	$Q = \frac{a_p \times a_e \times v_f}{1000}$	
Feed per tooth f_z [mm/tooth]	Effective diameter of cutting	
$f_z = h_m \times \sqrt{\frac{d_e}{a_e}}$ <p>valid only up to $\frac{a_e}{d_e} < 0,3$ respectively 30 % or $\varphi 60^\circ$</p>	$d_e = d_1 - d + 2 a_p \sqrt{(d - a_p)}$	
Setting angle	Feed per tooth	
90°	f_z	
45°	$f_z \cdot 1,414$	
30°	$f_z \cdot 2$	
otherwise	$f_z = \frac{h_m \times \pi \times d_e \times \varphi_s}{360 \times a_e \times \sin(k)}$	

Removal and solutions	Problem										
	Flank wear	Crater wear	Flaking	Thermal cracks	Fatigue cracks	Plastic deformation	Notch wear	Built-up edge	Cutting edge failure	Vibrations	Poor surface quality
Carbide grade with higher wear resistance	•	•				•	•				•
Tougher carbide grade			•	•	•				•		
Increase cutting speed			•					•			
Reduce cutting speed	•	•		•		•					
Increase feed per tooth	•							•		•	
Reduce feed per tooth			•	•	•	•	•		•		•
Change cutter position					•					•	
Smaller cutter diameter				•							
Improve rigidity			•				•		•		
Use coated grade	•	•						•			
Use coolant				•		•					

ISO	Germany		U.S.A.	France	Italy	Great Britain	European Standard
	W-Nr.	DIN	AISI/SAE	AFNOR	UNI	BS	EN
P	Construction steel and heat-treated steel						
	1.0572	St52-3	A570Gr50	A50-2	Fe490	Fe490-2FN	-
	1.0501	C35	1035	CC35	C35	060A35	-
	1.0503	C45	1045	CC45	C45	080M46	-
	1.0601	C60	1060	CC55	C60	080A62	43D
	1.0715	9SMn28	1213	S250	CF9SMn28	230M07	-
	1.0718	9SMnPb28	12L13	S250Pb	CF9SMnPb28	-	-
	1.0722	10SPb20	-	10PbF2	CF10SPb20	-	-
	1.1141	Ck15	1015	XC12	C16	080M15	32C
	1.1157	40Mn4	1039	35M5	-	150M36	15
	1.1158	Ck25	1025	-	-	-	-
	1.1167	36Mn5	1335	40M5	-	-	-
	1.1191	Ck45	1045	XC42	C45	080M46	-
	1.1203	Ck55	1055	XC55	C50	070M55	-
	1.1221	Ck60	1060	XC60	C60	080A62	43D
	1.1274	Ck101	1095	-	-	060A96	-
	1.3401	X120Mn12	-	Z120M12	G-X120Mn12	Z120M12	-
	1.3505	100Cr6	52100	100C6	100Cr6	534A99	31
	1.5026	100Cr6	9255	55S7	55Si8	250A53	45
	1.5415	15Mo3	ASTM A204Gr.A	15D3	16Mo3KW	1501-240	-
	1.5622	14Ni6	ASTM A350LF5	16N6	14Ni6	-	-
	1.5662	X8Ni9	ASTM A353	-	X10Ni9	1501-509;510	-
	1.5680	12Ni19	2515	Z18N5	-	-	-
	1.5710	36NiCr6	3135	35NC6	-	640A35	111A
	1.5752	14NiCr14	3415; 3310	12NC15	-	655M13	36A
						655A12	
	1.6511	36CrNiMo4	9840	40NCD3	38NiCrMo4(KB)	816M40	110
	1.6546	40NiCrMo22	8740	-	40NiCrMo2(KB)	311-Type 7	-
	1.6580	30CrNiMo8	-	30CrNiMo8	30CrNiMo8	-	-
	1.6587	17CrNiMo6	-	18NCD6	-	820A16	-
	1.6657	14NiCrMo134	-	-	15NiCrMo13	832M13	36C
	1.7015	15Cr3	5015	12C3	-	523M15	-
	1.7033	34Cr4	5132	32C4	34Cr4(KB)	530A32	18B
	1.7131	16MnCr5	5115	16MC5	16MnCr5	(527M20)	-
	1.7176	55Cr3	5155	55C3	-	527A60	48
	1.7218	25CrMo4	4130	25CD4	25CrMo4(KU)	1717CDS110	-
	1.7220	34CrMo4	4137; 4135	35CD4	35CrMo4	708A37	19B
	1.7225	42CrMo4	4140	42CD4	42CrMo4	708M40	19A
	1.7335	13CrMo4 4	ASTM A182 F11	15CD3.5	14CrMo4 5	1501-620Gr27	-
			F12	15CD4.5			
	1.7361	32CrMo12	-	30CD12	32CrMo12	722M24	40B
	1.7380	10CrMo9 10	ASTM A182 F.22	12CD9, 10	12CrMo9, 10	1501-622 Gr.31;45	-
	1.7715	14MoV6 3	-	-	-	1503-660-440	-
	1.8159	50CrV4	6150	50CV4	50CrV4	735A50	47
	1.8504	34CrAl6	-	-	-	-	-
	1.8509	41CrAlMo7	-	40CAD6, 12	41CrAlMo7	905M39	41B
	1.8523	39CrMoV13 9	-	-	36CrMoV12	897M39	40C

ISO	Germany		U.S.A.	France	Italy	Great Britain	European Standard
	W-Nr.	DIN	AISI/SAE	AFNOR	UNI	BS	EN
P	Tool steels						
	1.1545	C105W1	–	Y1105	C98KU	–	–
				C100KU			
	1.2067	100Cr6	L3	Y100C6	–	BL3	–
	1.2080	X210Cr12	D3	Z200C12	X210Cr13KU	BD3	–
				X250Cr12KU			
	1.2343	X38CrMoV5 1	H11	Z38CDV5	X37CrMoV51(KU)	BH11	–
	1.2344	X40CrMoV5 1	H13	Z40CDV5	X35CrMoV05KU	BH13	–
				X40CrMoV511KU			
	1.2363	X100CrMoV 5 1	A2	Z100CDV5	X100CrMoV51KU	BA2	–
	1.2379	X155CrVMo12 1	D2	Z160CDV12	X155CrVMo121KU	BD2	–
	1.2419	105WCr6	–	105WC13	10WCr6	–	–
				107WCr5KU			
	1.2436	X210CrW12	–	–	X215CrW12 1KU	–	–
	1.2542	45WCrV7	S1	–	45WCrV8KU	BS1	–
	1.2581	X30WCrV9 3	H21	Z30WCV9	X28W09KU	BH21	–
				X30WCrV9 3KU			
1.2601	X165CrMoV12	–	–	X165CrMoW12KU	–	–	
1.2713	55NiCrMoV6	L6	55NCDV7	–	–	–	
1.2833	100V1	W210	Y1105V	–	BW2	–	
1.3243	S 6-5-2-5	M41	Z85WDKCV	HS 6-5-2-5	–	–	
M	Stainless and heat resistant steels						
	1.4016	X8Cr17	430	Z8C17	X8Cr17	430S15	60
	1.4027	G-X20Cr14	–	Z20C13M	–	420C29	56B
	1.4034	X46Cr13	–	Z40CM	X40Cr14	420S45	56D
			Z38C13M				
	1.4057	X22CrNi17	431	Z15CNI6.02	X16CrNi16	431S29	57
	1.4104	X12CrMoS17	430F	Z10CF17	X10CrS17	–	–
	1.4113	X6CrMo17	434	Z8CD17.01	X8CrMo17	434S17	–
	1.4122	X35CrMo17	–	–	–	–	–
	1.4313	X5CrNi13 4	–	Z4CND13.4M	–	425C11	–
	1.4718	X45CrSi9 3	HW3	Z45CS 9	X45CrSi8	401S45	52
	1.4724	X10CrAl13	405	Z10C13	X10CrAl12	403S17	–
	1.4742	X10CrAl18	430	Z10CAS18	X8Cr17	430S15	60
	1.4747	X80CrNiSi20	HNV6	Z80CSN20.02	X80CrSiNi20	443S65	59
	1.4762	X10CrAl24	446	Z10CAS24	X16Cr26	–	–
	1.4871	X53CrMnNiN 219	EV8	Z52CMN21.09	X53CrMnNiN21 9	349S54	–

ISO	Germany		U.S.A.	France	Italy	Great Britain	European Standard
	W-Nr.	DIN	AISI/SAE	AFNOR	UNI	BS	EN
M	Rust- and acid-proof steels						
	1.4301	X5CrNi18-9	304	Z6CN18.09	X5CrNi 18 10	304S15	X5CrNi18-9
	1.4305	X12CrNiS18 8	303	Z10CNF18.09	X10CrNiS 18.09	303S21	58M
	1.4308	G-X6CrNi18 9	-	Z6CN18.10M	-	304C15	-
	1.4311	X2CrNiN 18 10	304LN	Z2CN18.10	-	304S62	-
	1.4362	X2CrNiN 23 4	S32304	-	-	-	-
	1.4401	X5CrNiMo 18 10	316	Z6CND17.11	X5CrNiMo17 12	316S16	-
	1.4408	G-X6CrNiMo 18 10	-	-	-	316C16	-
	1.4417	X2CrNiMoSi 19 5	S31500	-	-	-	-
	1.4429	X2CrNiMoN 18 13	316LN	Z2CND17.13	-	-	-
	1.4438	X2CrNiMo18 16	317L	Z2CND19.15	X2CrNiMo18 16	317S12	-
	1.4460	X8CrNiMo27 5	S32900	-	-	-	-
	1.4462	X2CrNiMoN 22 53	S31803	-	-	-	-
	1.4541	X10CrNiTi 18 9	321	Z6CNT18.10	X6CrNiTi18 11	2337	321S12
	1.4542	X5CrNiCuNb174	630	-	-	-	-
	1.4550	X10CrNiNb 18 9	347	Z6CNNb18.10	X6CrNiNb18 11	347S17	58F
	1.4571	X10CrNiMo18 10	316Ti	Z6NDT17.12	X6CrNiMoTi1712	320S17	58J
	1.4581	G-X5CrNi	-	Z4CNDNb	XG8CrNiMo	318C17	-
		MoNb 18 10		18 12M	18 11		-
	1.4583	X10CrNi	318	Z6CNDNb	X6CrNiMoNb	-	-
		MoNb 18 12		17 13B	17 13		-
	1.4828	X15CrNiSi20 12	309	Z15CNS20.12	-	309S24	-
	1.4845	X12CrNi25 21	310S	Z12CN25 20	X6CrNi25 20	310S24	-
	1.4864	X12NiCrSi36 16	330	Z12NCS35.16	-	-	-
	1.4865	G-X40NiCrSi38 18	-	-	XG50NiCr39 19	330C11	-
	1.4878	X12CrNiTi18 9	321	Z6CNT18.12B	X6CrNiTi1811	32S12	58B
	K	Grey cast iron (plain carbon)					
0.6015		GG15	No 25B	Ft 15 D	-	Grade 150	EN GJL-150
0.6025		GG25	No 35B	Ft 25 D	-	Grade 260	EN GJL-250
0.6035		GG35	No 50B	Ft 35 D	-	Grade 350	EN GJL-350
0.6040		GG40	No 55B	Ft 40 D	-	Grade 400	EN GJL-400
Grey cast iron (alloy)							
0.6660		GGL-NiCr 20 2	A436-72	L-NC 20 2	-	L-NiCr 20 2	EN GJLA-X NiCuCr 15-6-2
0.6680		GGL-NiCr 3055	-	-	-	-	EN GJLA-X NiCuCr 15-6-2
Spheroidal graphite cast iron (plain carbon)							
0.7040		GGG 40	60-40-18	FCS 400-12	-	SNG 420/12	EN GJ5-400-15
0.7060		GGG 60	-	FGS 600-3	-	SNG 600/3	EN GJ5-600-3
0.7070		GGG 70	100-70-03	FGS 700-2	-	SNG 700/2	EN GJ5-700-2
Spheroidal graphite cast iron (alloy)							
0.7652		GGG NiMn 13 7	-	L-NM 13 7	-	L-NiMn 13 7	EN GJLA-X NiCuCr 15-6-2
0.7660		GGG NiCr 20 2	-	L-NC 20 2	-	L-NiMn 20 2	-
Malleable cast iron							
0.8135		GTS-35-04	32510	MN 35-10	-	B 340/12	EN GJMB-350-10
0.8155		GTS-55-04	50005	MP 50-5	-	P 510/4	EN GJMB-550-4
0.8170		GTS-70-02	-	IP 70-2	-	P 690	EN GJMB-700-2

ISO	Germany		U.S.A.	France	Italy	Great Britain	European Standard	
	W-Nr.	DIN	AISI/SAE	AFNOR	UNI	BS	EN	
N	Non-ferrous heavy metal alloys							
	2.0321	CuZn37(Ms63)	C27400	CuZn37	P-CuZn37	CZ 108	CW508L	
	2.0402	CuZn40Pb2(Ms58)	C37700	CuZn39Pb2	P-CuZn3940Pb2	CZ 122	CW617N	
	2.0872	CuNi10Fe1Mn	C70600	CuNi10Fe1Mn	Pt-CuNi10Fe1Mn	CZ 135	CW352H	
	2.0920	CuAl8			P-CuAl8			
	2.0932	CuAl8Fe3	C61400	CuAl7Fe2	P-CuAl8Fe3	CA106	CW303G	
	2.0966	CuAl10Ni5Fe4	C63000	CuAl10Ni5Fe4		CA104	CW307G	
	2.0975	CuAl10Ni	C95800	CuAl10Fe5Ni5	CuAl11Fe4Ni4	AB2		
	2.1020	CuSn6	C51900	CuSn6P	CuSn7	PB103	CW452K	
	2.1498	CuSP			CuS(P0,01)			
	2.3205	PbSb5						
	2.3290	PbSb9						
	Light metal alloys							
	3.1355	AlCuMg2	AA 2024	2024	2024	2024	AW-2024	
	3.1645	AlCuMgPb					AW-2007	
	3.2581.01	AlSi12	B413.0	A-S 13	3051/G-AS9MG	LM6	AC-44200	
	3.3527	AlMg2Mn0,8					AW-5049	
	3.3535	AlMg3	AA 5754	5754			AW-5754	
	3.4365	AlZnMgCu1,5	AA 7075	7075	7075	7075	AW-7075	
	3.5312	MgAl3Zn	AZ31B	G-A3Z1		MAG-E-111	MG-P-62	
	3.5161	MgZn6Zr	ZK60A			MAG-E-161		
	3.5194	MgAl9Zn1	AZ91	G-A9Z1		MAG 7	MC-21120	
	3.7115	Ti-5Al-2,5Sn	Grade 6		T-A5E			
	3.7165	Ti-6Al-4V	Grade 5		T-A6V	TA10-13	Ti P63	
	3.7174	Ti-6Al-6V-2Sn	4971				Ti P64	
	S	High-temperature materials						
		Tradename						
HS-27		NiCo32Cr26Mo			KC20WN			
Hastelloy-C		NiMo16Cr15W	B366	NC17DWY	N01276		DIN 2.4819	
Inconel 718		NiCr19NbMo	5662		N07718	HR8	DIN 2.4668	
Lescalloy		NiCr16FeTi						
Nimonic90		NiCr20Co18Ti			N07090		DIN 2.4632	
Unitemp		NiCr16Co8WAlTi						
Vakumell		NiCr20TiAl						
Vakumelt		NiCo10Cr9WAlTi						
Alloy 625		NiCr22Mo9N	5599		N06625	NA21	DIN 2.4856	

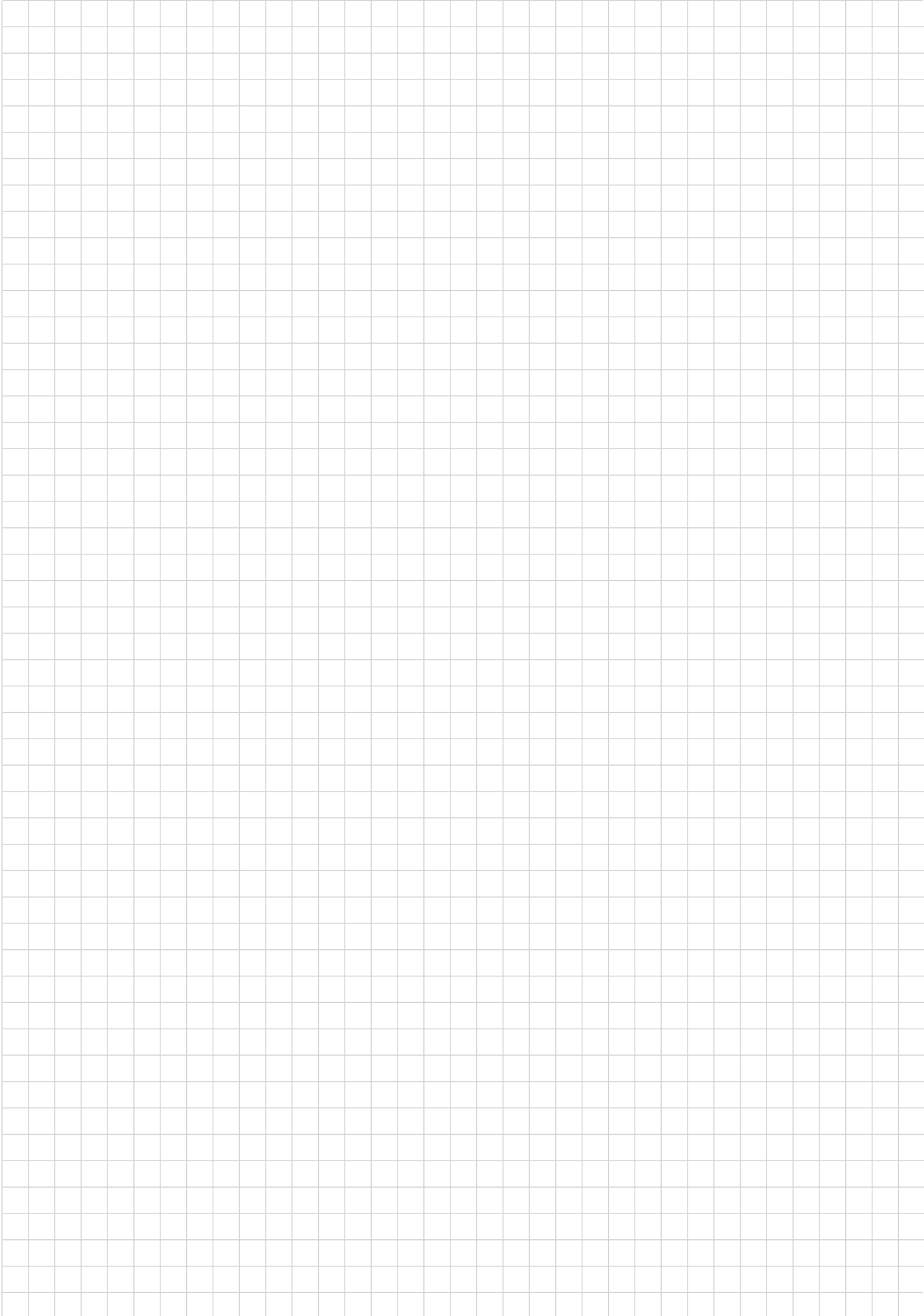

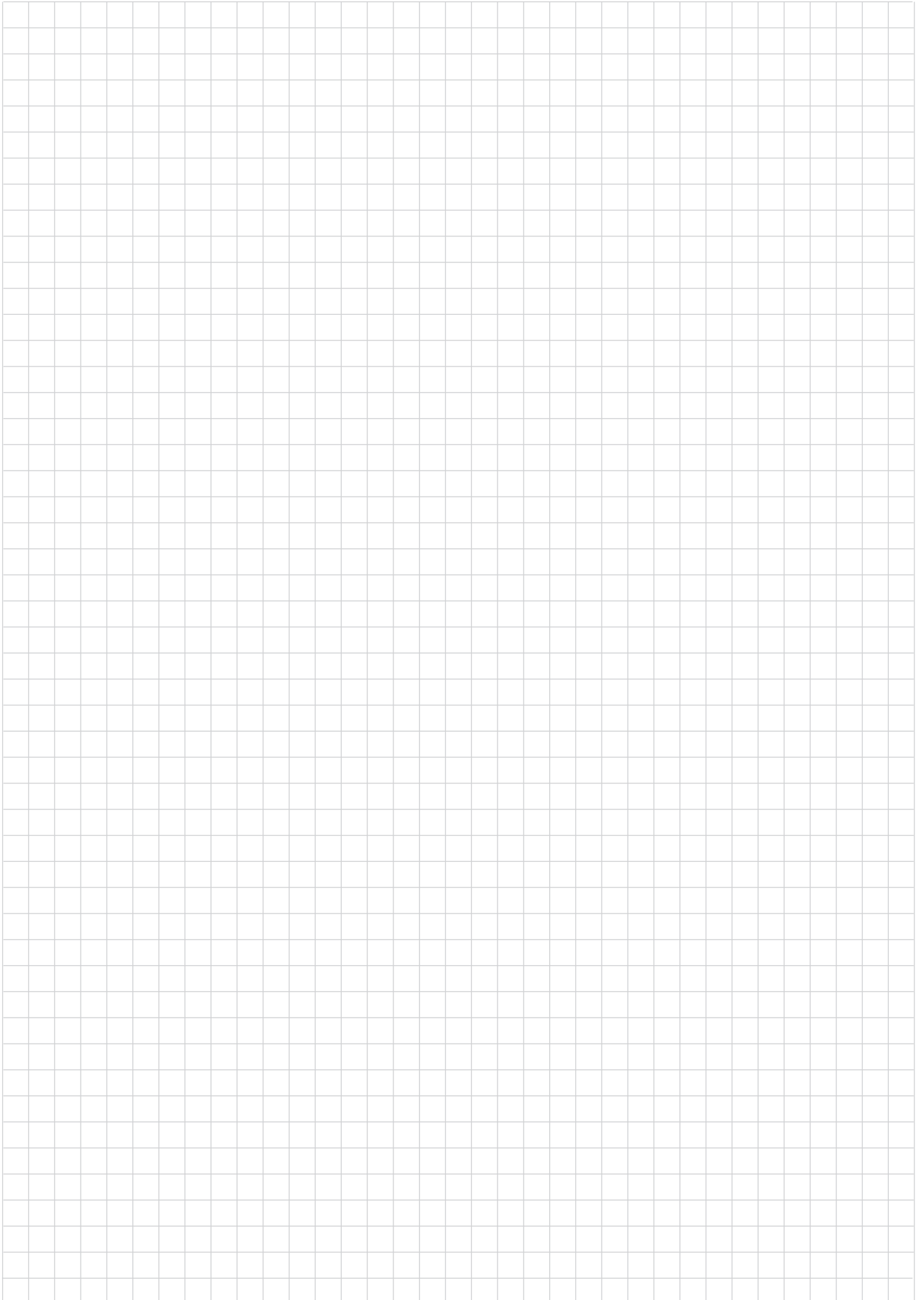

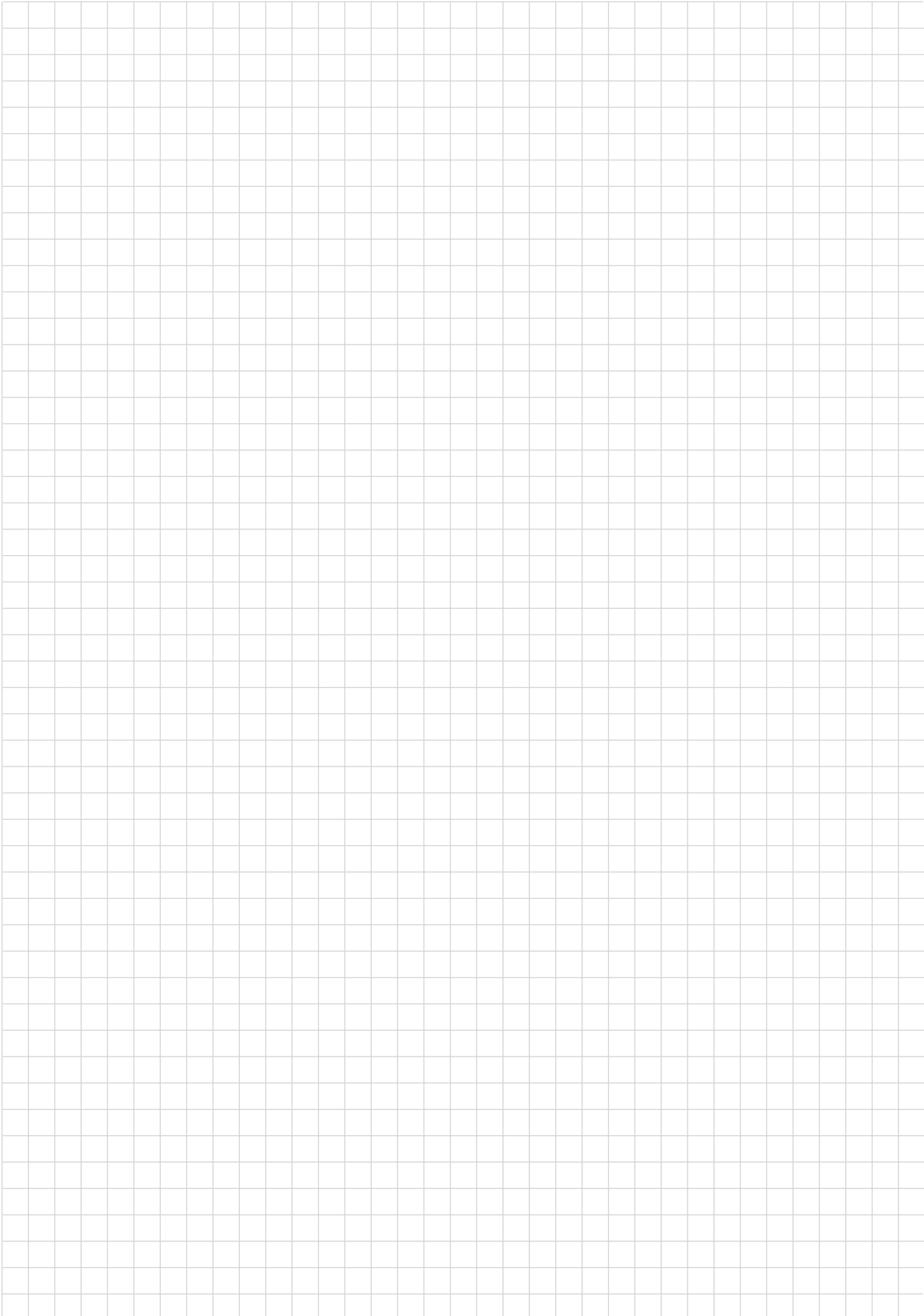



Deutschland / Germany

Hartmetall Werkzeugfabrik

Paul HORN GmbH

Unter dem Holz 33-35, D-72072 Tübingen

Tel +49 (0)7071/70040, Fax +49 (0)7071/72893

E-Mail: info@phorn.de, www.phorn.de

Großbritannien / UK and Ireland

HORN CUTTING TOOLS Ltd.

32 New Street, Ringwood, Hampshire,

BH24 3AD, Tel +44 (0)1425/481 800

Fax +44 (0)1425/481 888

E-Mail: info@phorn.co.uk, www.phorn.co.uk

Frankreich / France

HORN S.A.S

665, av. Blaise Pascal, Zone Industrielle,

77127 Lieusaint

Tel +33 (0)1648859-58, Fax +33 (0)1648860-49

E-Mail: infos@horn.fr, www.horn.fr

USA

HORN USA, Inc.

320 Premier Court, Suite 205, Franklin,

TN 37067

Tel +1 (888)818-HORN, Fax +1(615)771-4101

E-Mail: sales@hornusa.com, www.hornusa.com

Bulgarien-Rumänien-Kroatien-Serbien-Bosnien-Herzegowina-Montenegro

Bulgaria-Romania-Croatia-Serbia-Bosnia-Herzegovina-Montenegro

HORN Magyarország Kft.

H-9027 Győr, Gesztenyefa u. 4

Tel +36 96 55 05 31, Fax +36 96 55 05 32

E-Mail technik@phorn.hu, www.phorn.hu

China

HORN (Shanghai) Trading Co. Ltd.

Room 905, No. 518 Anyuan Road, P.R. of China

Putuo District, Shanghai 200060

上海市安远路518号905室 邮编: 200060

Tel: +86 21 52833505; 52833205

Fax: +86 21 52832562

E-Mail: info@phorn.cn, www.phorn.cn

Mexico

HORN HERRAMIENTAS MÉXICO

Av. Hércules # 500 Bodega #8

Polígono Empresarial Sta. Rosa

Santa Rosa Jáuregui, Querétaro

C.P. 76220

Tel.: +442 291-0321, Fax: +442 291-0915

E-Mail: ventas@phorn.mx, www.phorn.mx

Russland / Russia

HORN RUS LLC

121059, Moscow

5 Bryanskaya street

Tel.: +7 (495) 968 21 68, Fax +7 (495) 960 21 68

E-Mail: info@hornrus.com, www.hornrus.com



BLUECOMPETENCE

Alliance Member

Partner of the Engineering Industry
Sustainability Initiative

boehlerit

ph HORN ph