



Power. Precision. Performance.

**EXTREME
VERSATILITY.
SHEAR
POWER.**

**POW·R·FEED[®]
M9 SERIES**
FRACTIONAL AND METRIC CATALOG

**More slicing power.
More profit by the slice.**



CONTENTS:

Redefining high performance and versatility.

Get chatter-free machining, excellent surface finishes and incredible feed rates with POW•R•FEED M9 Series end mills. They're beasts at virtually any machining task and material you throw at them. IMCO M9s are setting the bar higher for feed rates, extended tool life, multipurpose performance and a lot more. That's IMCO technology, through and through.



Power. Precision. Performance.

POW•R•FEED® M9 Series Features

IMCO's POW•R•FEED end mills are the new benchmarks for "general-purpose" machining. For higher feeds and exceptional finishes, these are the tools you want.

8 **M924 Square End**

4-Flute • For maximum feed rates and longer tool life in most materials

11 **M924 Corner Radius**

4-Flute • For maximum feed rates and longer tool life in most materials

14 **M924N Corner Radius w/Neck Relief**

4-Flute • For optimized stability in deep reaching cuts

19 **M924B Ball End**

4-Flute • Full radius design combined with high-performance geometry

20 **M924NB Ball End w/Neck Relief**

4-Flute • Full radius design for deep reaching cuts

22 **M904 Square and Corner Radius**

4-Flute • For high feed rates in most materials and applications

27 **M904B Ball End**

4-Flute • Full radius design combined with high output

30 **M905 Square and Corner Radius**

5-Flute • For high feed rates and better surface finish in most materials

35 **How to build the new EZ-ID code.**

IMCO's new "smart" coding system saves time. Use these easy, step-by-step directions.

POW•R•FEED[®] M9 SERIES

“It’s like a general-purpose tool on steroids.”

That’s how users describe every POW•R•FEED M9 Series tool. M9s combine the versatility of a general-purpose end mill with the high-octane output of a high-performance mill. POW•R•FEED end mills can do it all because they have it all – including affordability. So you’ll never have to choose between quality and price.

The benefits of IMCO advanced POW•R•FEED technology.

- Longer tool life.
- Plunge, slot, rough, finish in all kinds of materials.
- Less chatter, longer tool life from unique vibration dampening geometry to reduce harmonics.
- Cut wet or dry, depending on your tool path and the material you’re machining.
- Use traditional milling methods or newer high-efficiency techniques.
- Maximum feeds and speeds you never thought possible.
- Amazing stability at any speed due to optimized geometries.

NEW! POW•R•FEED SERIES M924 END MILLS

IMCO’s new M924 is the second generation of the POW•R•FEED M9 Series, designed for production environments. Reinforced cutting edges give you even longer tool life in more demanding applications.

- Better performance, longer tool life with optimized rake and relief angles.
- New AlCrNX engineered coating shown to improve tool life exponentially.

These performance benefits make the new M924 end mills an excellent choice when:

- Speed and cycle time are critical.
- High-volume part runs make it easy to measure tool life.

POW•R•FEED M904 END MILLS

IMCO’s M904s are the tools to count on, with four variable flutes designed for the job shop environment, especially when:

- Machining short-run jobs and cycle time is critical.
- Machining many different materials as a rule in your shop environment.
- Measuring tool life by the number of jobs completed, not just parts made.

POW•R•FEED M905 END MILLS

IMCO’s M905 is a supplemental geometry for difficult-to-machine materials and applications requiring improved surface finish. Five flutes provide maximum cutting edge engagement and better surface finishes.

M924: POW•R•FEED’s New Powerhouse

IMCO advances in cutting geometries and coatings can make a significant difference in your results, as shown in these graphs. All other variables being equal, IMCO’s POW•R•FEED M924 achieved the highest metal removal rate in both tests and both metals, compared with a competitor’s product as well as the original POW•R•FEED M904.

CUBIC INCHES REMOVED

17-4 PH Stainless Steel: Peripheral Milling

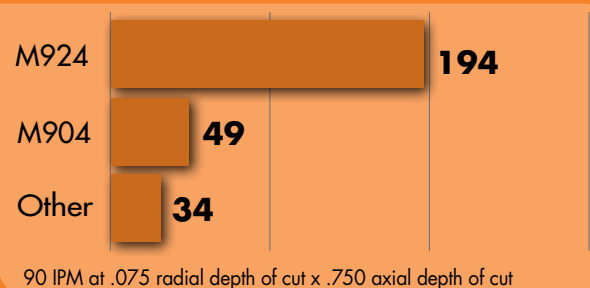

4140 Steel: Peripheral Milling

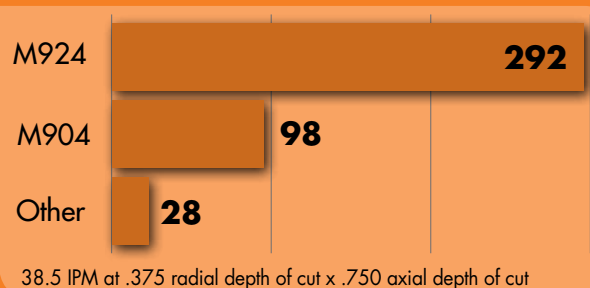

POW•R•FEED® M9 Series Features



Options

End designs

Corner radii – a wide variety available to meet your part's specific requirements. Helps prevent corner chipping.

Square end – for general machining and finishing.

Ball end – for precision contouring.

Shank designs

h6 tolerance shanks – fit all collets and conform to shrink-fit requirements.

Many styles and sizes offered with flats for Weldon-style holders.

Choose the length for the job.

Extra rigidity – choose stub length.

Medium to deep cuts – order standard or long length.

Choose the right tool for your shop.

M9 Series end mills make fast work of most machining work in these materials:



Carbon and tool steels

Martensitic and ferritic stainless steels as well as carbon and tool steels



Cast iron

Malleable and gray cast irons



Stainless steels

Austenitic and precipitation hardening stainless steels



Heat-resistant super alloys

Titanium and heat-resistant alloys

High-efficiency machining + POW•R•FEED technology = WIN-WIN.

The numbers prove it: high-efficiency machining saves time and extends tool life. And high-efficiency machining with POW•R•FEED end mills is a winning combination. The M9 Series is designed from the ground up for constant radial engagement machining, a revolutionary technique that maximizes metal removal rates.

What is high-efficiency machining?

Traditional machining techniques often generate high cutting forces and exert stress on the tool, causing premature tool wear and limited speeds and feeds. Result: you get shorter tool life and longer cycle time.

High-efficiency machining uses constant radial engagement tool paths, so cutting forces are reduced, tool output is increased and metal removal rates are maximized. These tool paths employ light stepovers, deep axial cuts, rolling entries and exits from the material and "driving" the corners to form internal radii.

You'll find several software products for optimizing tool paths on the market. POW•R•FEED M9 mills achieve amazing metal removal rates when used in conjunction with MasterCam Dynamic Milling,[®] VoluMill[™] or TrueMill[®] software.

Maximizing tool performance.

Removes more material – The tool can cut deeper with lighter stepovers, allowing higher speed rates and heavier chip loads for higher metal removal rates.

Improves surface finish – Continuous tool paths engage more of the cutting edges in the work material at all times, yielding a better surface finish.

Reduces deflection – Lighter stepovers generate less cutting pressure and reduce tool deflection, resulting in straighter walls.

Better tool life – Uniform chip load reduces stress on the tool, resulting in longer life.

Put it to work and watch the chips fly!

Superior surface finishes, straighter walls, higher metal removal rates and longer tool life. The reasons are clear: combined with high-efficiency machining, POW•R•FEED mills are the tools of choice.

How it works.

1. Arcing the mill counter-clockwise into the cut (instead of a straight entry) improves tool life.

- Reduces chip thickness as each cutting edge exits the material.
- Reduces cutter vibration during entry into the work material.

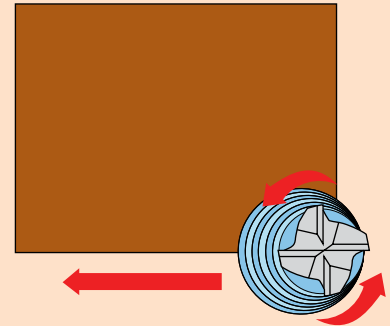

2. A light radial cut (a_e) generates higher feed rates.

- Creates a thinner chip, which reduces the heat at the cutting zone.
- Improves cutter stability by reducing radial cutting forces.

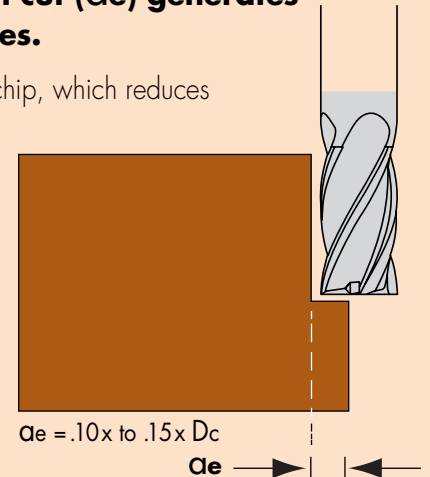

3. Deeper-than-normal axial cuts (a_p) generate high metal removal rates.

- Increases tool engagement and stability.
- Program axial depth of cut at 1.5x to 2x the cutter diameter.

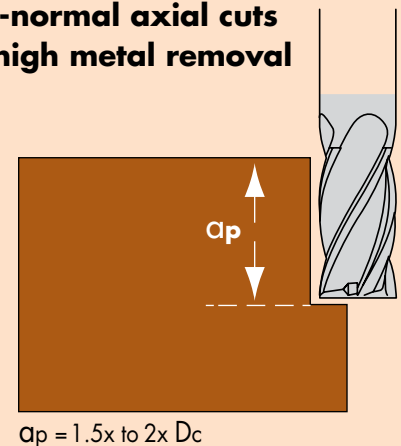

High-efficiency machining and internal corners.

Maximize tool life and productivity by “slicing,” then “driving” internal corners.

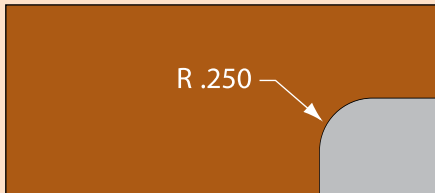

This example shows a part profile with a .250 radius.

Step 1 “Slice” the material away from the corners using a straight-line tool path and a radial stepover of 10% of the cutter diameter. Speeds can be programmed at 1.5x to 2x normal slotting speeds (see HEM recommendations on page 6). This method reduces stress on the part and the tool.

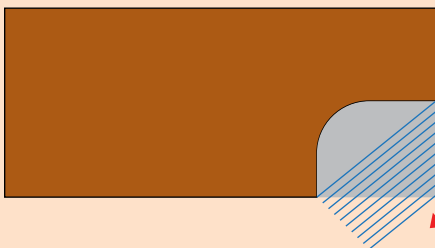

Remove corners at accelerated speed and feed using light stepovers with 1/2" end mill.

Step 2 “Drive” the mill into the corner to remove most of the remaining material. Program a radius that is 40% larger than the final radius. Continue to use light radial stepovers to maintain maximum feed rates.

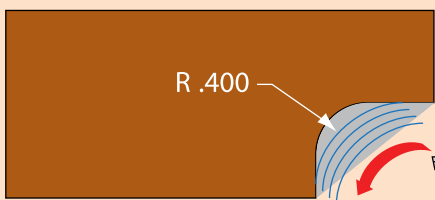

Remove remaining material in corner with 1/2" end mill driving a radius 40% larger than the final radius.

Step 3 “Drive” a smaller mill into the corner to achieve the desired radius.

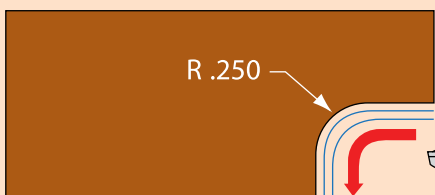

Machine the finished .250 radius with a 3/8" end mill, allowing you to “drive” the corner.

Selecting the Right Holder

The correct holder is as important as the right tool. Every holder style has advantages. The critical issue is runout: the less the runout, the better the tool performance. Excessive runout reduces tool life and performance, especially at high spindle speeds. Whatever your choice, take the time to indicate a new tool in the spindle. A few minutes taken during setup can yield great performance results.

It’s common to use collets and collet holders when milling. Make sure the collets are clean and not bell-mouthed from overuse or misuse. The collet holder with the shortest overhang allowable is always the best choice.

Using an end mill holder is great for heavy roughing. For best performance, use a mill with a factory-ground flat.

Shrink-fit and press-fit systems work well at all speeds and feeds but especially when running over 8,000 rpm or in deep-reaching applications. These systems balance the mill with low total indicator runout (TIR) that are critical when running in aggressive applications or less-than-ideal setups.



NEW TOOL

POW•R•FEED® M924: The M9 Series Powerhouse

The M924 is an elegant monster of a tool. It takes advantage of all of IMCO's latest advances: refined geometries, an even better heat-resistant premium coating – AlCrNX – and reinforced cutting edges.

The results are amazing.

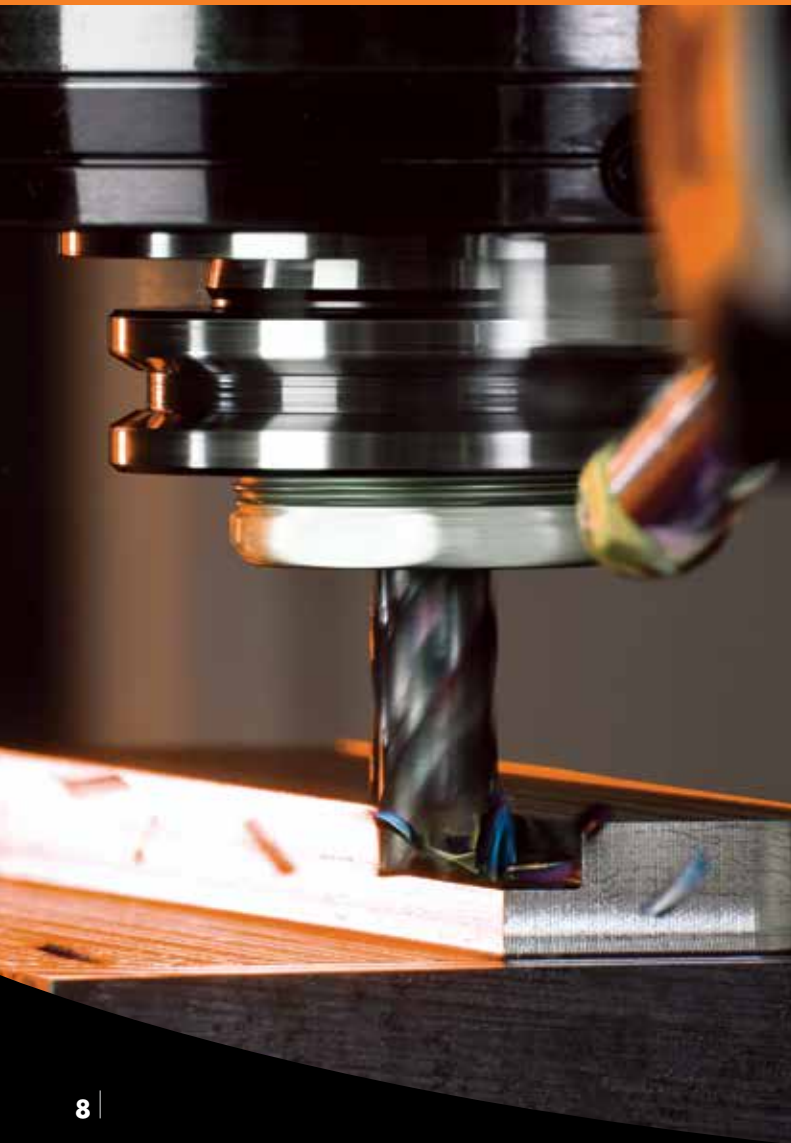

M924

Square End



For high-performance milling in a wide range of materials and applications. Designed to be free cutting with superior edge strength. Recommended for high-volume production runs and difficult-to-machine materials. Use square corner for general finishing operations, and corner radius for roughing and semi-finishing operations.

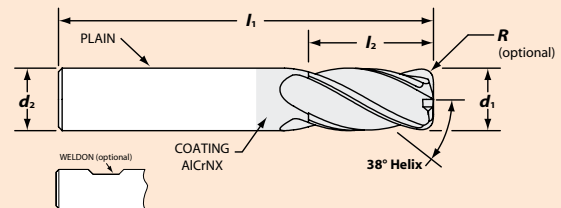

in $d_1: +0.000 / -0.002$ $d_2: h_6$
mm $d_1: +0,000 / -0,050$ $d_2: h_6$

Use M924 plain shank with milling chuck, collet or shrink-fit tool holders to minimize TIR when performing high-efficiency machining or finishing operations.

Model Code: M924
w/Square End and Plain Shank 

Model Code: M924
w/Square End and Weldon Shank 

Cutter Dia d1	Shank Dia d2	Length of Cut l2	Overall Length l1	Order Code	EZ-ID Number M924-xxxx-xxxx-SQ d1 l2
1/8	1/8	1/4	1-1/2	67494	M924-0125-0250-SQ
		1/2	1-1/2	67498	M924-0125-0500-SQ
		3/4	2-1/4	67502	M924-0125-0750-SQ
5/32	3/16	5/16	2	67536	M924-0156-0312-SQ
		9/16	2	67537	M924-0156-0562-SQ
3/16	3/16	5/16	2	67506	M924-0187-0312-SQ
		9/16	2	67510	M924-0187-0562-SQ
		3/4	2-1/2	67514	M924-0187-0750-SQ
7/32	1/4	3/8	2	67541	M924-0218-0375-SQ
		3/4	2-1/2	67542	M924-0218-0750-SQ
1/4	1/4	3/8	2	67518	M924-0250-0375-SQ
		3/4	2-1/2	67524	M924-0250-0750-SQ
		1-1/4	3	67530	M924-0250-1250-SQ
		1-3/4	4	67546	M924-0250-1750-SQ
9/32	5/16	3/4	2-1/2	67549	M924-0281-0750-SQ
5/16	5/16	7/16	2	67092	M924-0312-0437-SQ
		13/16	2-1/2	67098	M924-0312-0812-SQ
		1-1/4	3	67104	M924-0312-1250-SQ
		2-1/8	4	67110	M924-0312-2125-SQ
11/32	3/8	7/8	2-1/2	67552	M924-0343-0875-SQ
3/8	3/8	1/2	2	67116	M924-0375-0500-SQ
		7/8	2-1/2	67124	M924-0375-0875-SQ
		1-1/4	3	67132	M924-0375-1250-SQ
		1-5/8	4	67148	M924-0375-1625-SQ
		2	4	67164	M924-0375-2000-SQ
		2-1/2	5	67554	M924-0375-2500-SQ
13/32	7/16	1	2-3/4	67557	M924-0406-1000-SQ
7/16	7/16	5/8	2-1/2	67180	M924-0437-0625-SQ
		1	2-3/4	67188	M924-0437-1000-SQ
		2	4	67196	M924-0437-2000-SQ
1/2	1/2	5/8	2-1/2	67204	M924-0500-0625-SQ
		1	3	67213	M924-0500-1000-SQ
		1-1/4	3	67222	M924-0500-1250-SQ
		1-5/8	4	67231	M924-0500-1625-SQ
		2-1/8	4	67249	M924-0500-2125-SQ
		2-5/8	5	67258	M924-0500-2625-SQ
		3-1/4	6	67267	M924-0500-3250-SQ
		9/16	9/16	1-1/4	3-1/2
5/8	5/8	3/4	3	67276	M924-0625-0750-SQ
		1-3/8	3-1/2	67286	M924-0625-1375-SQ
		2-1/8	4	67296	M924-0625-2125-SQ
		2-5/8	5	67316	M924-0625-2625-SQ
		3-1/4	6	67326	M924-0625-3250-SQ
3/4	3/4	1	3	67346	M924-0750-1000-SQ
		1-5/8	4	67356	M924-0750-1625-SQ
		2-3/8	5	67366	M924-0750-2375-SQ
		3-1/4	6	67386	M924-0750-3250-SQ
		4-1/8	7	67396	M924-0750-4125-SQ
		1-3/4	4	67406	M924-1000-1750-SQ
1	1	2-1/4	5	67417	M924-1000-2250-SQ
		3-1/4	6	67439	M924-1000-3250-SQ
		4-1/4	7	67450	M924-1000-4250-SQ
		2	4-1/2	67461	M924-1250-2000-SQ
1-1/4	1-1/4	3-1/4	6	67472	M924-1250-3250-SQ
		5	8	67483	M924-1250-5000-SQ

Cutter Dia d1	Shank Dia d2	Length of Cut l2	Overall Length l1	Order Code	EZ-ID Number M924-xxxx-xxxx-SQ-W d1 l2
3/8	3/8	7/8	2-1/2	68195	M924-0375-0875-SQ-W
		1-1/4	3	68196	M924-0375-1250-SQ-W
		1-5/8	4	68197	M924-0375-1625-SQ-W
		2	4	68198	M924-0375-2000-SQ-W
7/16	7/16	2-1/2	5	68221	M924-0375-2500-SQ-W
		1	2-3/4	68199	M924-0437-1000-SQ-W
		2	4	68200	M924-0437-2000-SQ-W
1/2	1/2	1	3	68710	M924-0500-1000-SQ-W
		1-1/4	3	68201	M924-0500-1250-SQ-W
		1-5/8	4	68202	M924-0500-1625-SQ-W
		2-1/8	4	68203	M924-0500-2125-SQ-W
		2-5/8	5	68204	M924-0500-2625-SQ-W
		3-1/4	6	68205	M924-0500-3250-SQ-W
5/8	5/8	1-3/8	3-1/2	68206	M924-0625-1375-SQ-W
		2-1/8	4	68207	M924-0625-2125-SQ-W
		2-5/8	5	68208	M924-0625-2625-SQ-W
		3-1/4	6	68209	M924-0625-3250-SQ-W
3/4	3/4	1-5/8	4	68210	M924-0750-1625-SQ-W
		2-3/8	5	68211	M924-0750-2375-SQ-W
		3-1/4	6	68212	M924-0750-3250-SQ-W
		4-1/8	7	68213	M924-0750-4125-SQ-W
1	1	1-3/4	4	68214	M924-1000-1750-SQ-W
		2-1/4	5	68215	M924-1000-2250-SQ-W
		3-1/4	6	68216	M924-1000-3250-SQ-W
		4-1/4	7	68217	M924-1000-4250-SQ-W
1-1/4	1-1/4	2	4-1/2	68218	M924-1250-2000-SQ-W
		3-1/4	6	68219	M924-1250-3250-SQ-W
		5	8	68220	M924-1250-5000-SQ-W

WHEN IS A ROUGHER NOT A ROUGHER?

POW•R•FEED® end mills are designed to achieve a high metal removal rate – the job for a rougher. The unique combination of design, substrate and coating also allows POW•R•FEED M9s to yield excellent finishes, potentially saving polishing time on parts with critical surface finish requirements.

Model Code: M924
w/Square End and Plain Shank **P**

Cutter Dia d1	Shank Dia d2	Length of Cut l2	Overall Length l1	Order Code	EZ-ID Number M924-xxx-xxx-SQ d1 l2
3	3	9	38	67900	M924-030-009-SQ
		12	38	67902	M924-030-012-SQ
		25	75	67904	M924-030-025-SQ
3	6	9	50	67906	M924-030-009-SQ
		12	57	67909	M924-030-012-SQ
4	6	12	54	67912	M924-040-012-SQ
		16	63	67915	M924-040-016-SQ
5	6	15	54	67918	M924-050-015-SQ
		20	63	67921	M924-050-020-SQ
6	6	13	57	67924	M924-060-013-SQ
		19	63	67928	M924-060-019-SQ
		25	75	67932	M924-060-025-SQ
7	8	19	63	67936	M924-070-019-SQ
8	8	19	63	67939	M924-080-019-SQ
		32	75	67942	M924-080-032-SQ
9	10	22	72	67945	M924-090-022-SQ
10	10	22	72	67948	M924-100-022-SQ
		40	88	67953	M924-100-040-SQ
12	12	19	73	67956	M924-120-019-SQ
		26	83	67959	M924-120-026-SQ
		50	100	67964	M924-120-050-SQ
		75	150	67967	M924-120-075-SQ
14	14	32	83	67970	M924-140-032-SQ
16	16	34	92	67975	M924-160-034-SQ
		55	110	67980	M924-160-055-SQ
		75	150	67983	M924-160-075-SQ
20	20	38	104	67986	M924-200-038-SQ
		42	100	67991	M924-200-042-SQ
		65	125	67996	M924-200-065-SQ
		85	150	67999	M924-200-085-SQ
25	25	52	120	68002	M924-250-052-SQ
		85	150	68007	M924-250-085-SQ

Model Code: M924
w/Square End and Weldon Shank **W**

Cutter Dia d1	Shank Dia d2	Length of Cut l2	Overall Length l1	Order Code	EZ-ID Number M924-xxx-xxx-SQ-W d1 l2
6	6	13	57	68222	M924-060-013-SQ-W
		19	63	68223	M924-060-019-SQ-W
		25	75	68224	M924-060-025-SQ-W
8	8	19	63	68225	M924-080-019-SQ-W
		32	75	68226	M924-080-032-SQ-W
10	10	22	72	68227	M924-100-022-SQ-W
		40	88	68228	M924-100-040-SQ-W
12	12	26	83	68229	M924-120-026-SQ-W
		50	100	68230	M924-120-050-SQ-W
16	16	75	150	68231	M924-120-075-SQ-W
		34	92	68232	M924-160-034-SQ-W
		55	110	68233	M924-160-055-SQ-W
20	20	75	150	68234	M924-160-075-SQ-W
		38	104	68235	M924-200-038-SQ-W
		42	100	68236	M924-200-042-SQ-W
		65	125	68237	M924-200-065-SQ-W
25	25	85	150	68238	M924-200-085-SQ-W
		52	120	68239	M924-250-052-SQ-W
		85	150	68240	M924-250-085-SQ-W



CASE STUDY

Putting the "POW" into Pow·R·Feed!

The new features on the M924 make it an incredibly durable tool – extending the tool life in many applications. One IMCO customer was using the original M904 mill and a leading competitor’s mill in a tough chrome application. By changing to the M924 the customer cut five times the parts per tool – without lowering the metal removal rate. That’s a double savings – more parts per tool and fewer tool changes. Combine the great tool life with the aggressive feed rates and the M924 is a very Pow-R-Full tool.

Model Code: M924 w/Corner Radius and Plain Shank

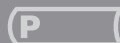

M924

Corner Radius



Using an end mill with a corner radius greatly extends tool life in most applications, especially roughing cuts and those in materials with low machinability ratings. Corner chipping can lead to tool failure and poor finishes. Adding a corner radius reduces chipping and improves tool life by protecting the weakest part of the end mill.

Cutter Dia d1	Shank Dia d2	Length of Cut l2	Overall Length l1	Order Code by Corner Radius (R)					EZ-ID Number			
				(replace .xxx in EZ-ID number with decimal size below)	.015 CR	.030 CR	.060 CR	.090 CR	.120 CR	M924-xxxx-xxxx-xxx d1 l2 R		
1/8	1/8	1/4	1-1/2	67495								M924-0125-0250-xxx
		1/2	1-1/2	67499								M924-0125-0500-xxx
		3/4	2-1/4	67503								M924-0125-0750-xxx
5/32	3/16	5/16	2	67538								M924-0156-0312-xxx
		9/16	2	67539								M924-0156-0562-xxx
3/16	3/16	5/16	2	67507	67508							M924-0187-0312-xxx
		9/16	2	67511	67512							M924-0187-0562-xxx
		3/4	2-1/2	67515	67516							M924-0187-0750-xxx
7/32	1/4	3/8	2	67543								M924-0218-0375-xxx
		3/4	2-1/2	67544								M924-0218-0750-xxx
1/4	1/4	3/8	2	67519	67520							M924-0250-0375-xxx
		3/4	2-1/2	67525	67526	67527						M924-0250-0750-xxx
		1-1/4	3	67531	67532							M924-0250-1250-xxx
		1-3/4	4	67547	67548							M924-0250-1750-xxx
9/32	5/16	3/4	2-1/2	67550	67551						M924-0281-0750-xxx	
5/16	5/16	7/16	2	67093	67094							M924-0312-0437-xxx
		13/16	2-1/2	67099	67100	67101						M924-0312-0812-xxx
		1-1/4	3	67105	67106							M924-0312-1250-xxx
		2-1/8	4	67111	67112							M924-0312-2125-xxx
11/32	3/8	7/8	2-1/2		67553						M924-0343-0875-xxx	
3/8	3/8	1/2	2	67117	67118							M924-0375-0500-xxx
		7/8	2-1/2	67125	67126	67127	67128					M924-0375-0875-xxx
		1-1/4	3	67133	67134	67135						M924-0375-1250-xxx
		1-5/8	4	67149	67150	67151						M924-0375-1625-xxx
		2	4	67165	67166	67167						M924-0375-2000-xxx
		2-1/2	5	67555	67556						M924-0375-2500-xxx	
13/32	7/16	1	2-3/4		67558						M924-0406-1000-xxx	
7/16	7/16	5/8	2-1/2		67182							M924-0437-0625-xxx
		1	2-3/4		67190							M924-0437-1000-xxx
		2	4		67198							M924-0437-2000-xxx
1/2	1/2	5/8	2-1/2		67206	67207						M924-0500-0625-xxx
		1	3	67214	67215	67216	67217	67218				M924-0500-1000-xxx
		1-1/4	3	67223	67224	67225	67226	67227				M924-0500-1250-xxx
		1-5/8	4		67233	67234	67235	67236				M924-0500-1625-xxx
		2-1/8	4		67251	67252	67253	67254				M924-0500-2125-xxx
		2-5/8	5		67260	67261						M924-0500-2625-xxx
		3-1/4	6		67269	67270					M924-0500-3250-xxx	
9/16	9/16	1-1/4	3-1/2		67560						M924-0562-1250-xxx	
5/8	5/8	3/4	3		67278	67279						M924-0625-0750-xxx
		1-3/8	3-1/2		67288	67289	67290	67291				M924-0625-1375-xxx
		2-1/8	4		67298	67299	67300	67301				M924-0625-2125-xxx
		2-5/8	5		67318	67319						M924-0625-2625-xxx
		3-1/4	6		67328	67329						M924-0625-3250-xxx
3/4	3/4	1	3		67348	67349						M924-0750-1000-xxx
		1-5/8	4		67358	67359	67360	67361				M924-0750-1625-xxx
		2-3/8	5		67368	67369	67370	67371				M924-0750-2375-xxx
		3-1/4	6		67388	67389						M924-0750-3250-xxx
		4-1/8	7		67398	67399					M924-0750-4125-xxx	
1	1	1-3/4	4		67408	67409	67410	67411				M924-1000-1750-xxx
		2-1/4	5		67419	67420		67422				M924-1000-2250-xxx
		3-1/4	6		67441	67442						M924-1000-3250-xxx
		4-1/4	7		67452	67453						M924-1000-4250-xxx
1-1/4	1-1/4	2	4-1/2		67463	67464			67466			M924-1250-2000-xxx
		3-1/4	6		67474	67475			67477			M924-1250-3250-xxx
		5	8		67485	67486			67488			M924-1250-5000-xxx

Model Code: M924 w/Corner Radius and Weldon Shank



Cutter Dia d1	Shank Dia d2	Length of Cut l2	Overall Length l1	Order Code by Corner Radius (R) (replace .xxx in EZ-ID number with decimal size below)				EZ-ID Number		
				.015 CR	.030 CR	.060 CR	.120 CR	M924-xxxx-xxxx-xxx-W d1 l2 R		
3/8	3/8	7/8	2-1/2	68116	68117	68118		M924-0375-0875-xxx-W		
		1-1/4	3	68119	68120	68121		M924-0375-1250-xxx-W		
		1-5/8	4	68122	68123	68124		M924-0375-1625-xxx-W		
		2	4	68125	68126	68127		M924-0375-2000-xxx-W		
1/2	1/2	1	3	68711	68712	68713	68714	M924-0500-1000-xxx-W		
		1-1/4	3	68131	68132	68133	68134	M924-0500-1250-xxx-W		
		1-5/8	4		68136	68137		M924-0500-1625-xxx-W		
		2-1/8	4		68139	68140		M924-0500-2125-xxx-W		
		2-5/8	5		68142	68143		M924-0500-2625-xxx-W		
		3-1/4	6		68145	68146		M924-0500-3250-xxx-W		
		1-3/8	3-1/2		68147	68148		M924-0625-1375-xxx-W		
5/8	5/8	2-1/8	4		68149	68150		M924-0625-2125-xxx-W		
		2-5/8	5		68151	68152		M924-0625-2625-xxx-W		
		3-1/4	6		68153	68154		M924-0625-3250-xxx-W		
		1-5/8	4		68155	68156	68157	M924-0750-1625-xxx-W		
3/4	3/4	2-3/8	5		68158	68159	68160	M924-0750-2375-xxx-W		
		3-1/4	6		68161	68162		M924-0750-3250-xxx-W		
		4-1/8	7		68164	68165		M924-0750-4125-xxx-W		
		1-3/4	4		68167	68168	68169	M924-1000-1750-xxx-W		
1	1	2-1/4	5		68171	68172	68173	M924-1000-2250-xxx-W		
		3-1/4	6		68175	68176		M924-1000-3250-xxx-W		
		4-1/4	7		68179	68180		M924-1000-4250-xxx-W		
		2	4-1/2		68183	68184	68185	M924-1250-2000-xxx-W		
1-1/4	1-1/4	3-1/4	6		68187	68188	68189	M924-1250-3250-xxx-W		
		5	8		68191	68192	68193	M924-1250-5000-xxx-W		



CASE STUDY

More Parts Per Tool

Never underestimate the power of the coating. Tested in 6AL-4V titanium against a tool with a different coating, the POW•R•FEED M9 tool lasted 60% longer, simply due to the advanced AlCrNX coating. That translates into a 60% parts-per-tool increase and takes a big bite out of the customer's ongoing tool costs.

Model Code: M924 w/Corner Radius and Plain Shank

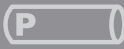

Cutter Dia d1	Shank Dia d2	Length of Cut l2	Overall Length l1	Order Code by Corner Radius (R) (replace -xxx in EZ-ID number with mm size below)			EZ-ID Number M924-xxx-xxx-xxx-Lxxx			
				0,3 CR	0,5 CR	1,0 CR	d1	l2	R	l1
3	3	9	38	67901			M924-030-009-xxx			
		12	38	67903			M924-030-012-xxx			
		25	75	67905			M924-030-025-xxx			
3	6	9	50	67907			M924-030-009-xxx			
		12	57	67910			M924-030-012-xxx-L57			
4	6	12	54	67913			M924-040-012-xxx			
		16	63	67916			M924-040-016-xxx			
5	6	15	54	67919			M924-050-015-xxx			
		20	63	67922			M924-050-020-xxx			
6	6	13	57	67925	67926		M924-060-013-xxx			
		19	63	67929	67930		M924-060-019-xxx			
		25	75	67933	67934		M924-060-025-xxx			
7	8	19	63		67937		M924-070-019-xxx			
8	8	19	63		67940		M924-080-019-xxx			
		32	75		67943		M924-080-032-xxx			
9	10	22	72		67946		M924-090-022-xxx			
10	10	22	72		67949	67950	M924-100-022-xxx			
		40	88		67954		M924-100-040-xxx			
12	12	19	73		67957	67958	M924-120-019-xxx			
		26	83		67960	67961	M924-120-026-xxx			
		50	100		67965		M924-120-050-xxx			
12	12	75	150		67968		M924-120-075-xxx			
		32	83		67971	67972	M924-140-032-xxx			
16	16	34	92		67976	67977	M924-160-034-xxx			
		55	110		67981		M924-160-055-xxx			
		75	150		67984		M924-160-075-xxx			
20	20	38	104		67987	67988	M924-200-038-xxx			
		42	100		67992	67993	M924-200-042-xxx			
		65	125		67997		M924-200-065-xxx			
25	25	85	150		68000		M924-200-085-xxx			
		52	120		68003	68004	M924-250-052-xxx			
		85	150		68008		M924-250-085-xxx			

Model Code: M924 w/Corner Radius and Weldon Shank



Cutter Dia d1	Shank Dia d2	Length of Cut l2	Overall Length l1	Order Code by Corner Radius (R) (replace -xxx in EZ-ID number with mm size below)		EZ-ID Number M924-xxx-xxx-xxx-Lxxx			
				0,5 CR	1,0 CR	d1	l2	R	l1
6	6	13	57	67927		M924-060-013-xxx-W			
		19	63	67931		M924-060-019-xxx-W			
		25	75	67935		M924-060-025-xxx-W			
8	8	19	63	67941		M924-080-019-xxx-W			
		32	75	67944		M924-080-032-xxx-W			
10	10	22	72	67951	67952	M924-100-022-xxx-W			
		40	88	67955		M924-100-040-xxx-W			
12	12	26	83	67962	67963	M924-120-026-xxx-W			
		50	100	67966		M924-120-050-xxx-W			
		75	150	67969		M924-120-075-xxx-W			
16	16	34	92	67978	67979	M924-160-034-xxx-W			
		55	110	67982		M924-160-055-xxx-W			
		75	150	67985		M924-160-075-xxx-W			
20	20	38	104	67989	67990	M924-200-038-xxx-W			
		42	100	67994	67995	M924-200-042-xxx-W			
		65	125	67998		M924-200-065-xxx-W			
25	25	85	150	68001		M924-200-085-xxx-W			
		52	120	68005	68006	M924-250-052-xxx-W			
85	150	68009		M924-250-085-xxx-W					

TOOL TIP

Twice the Power: M924 w/2xD Flute Length

Put your metal removal rate into high gear with IMCO's 2xD flute length. Most tools made for cavity work use a 1:1 diameter-to-flute ratio for flute length. In addition to the 1xD ratio, IMCO offers the 2xD ratio which gives you twice the cutting depth in cavity work – without the loss of tool strength, balance and rigidity. How does IMCO do this? It's our solid carbide core and advanced geometries that keep the tool working and the chips flying.



M924

Corner Radius w/Neck Relief



M924N permits clearance in deeper cavities and easier machining against tight walls. Neck relief and short flute length mean increased stability of the end mill in the cut for more precise tolerances.

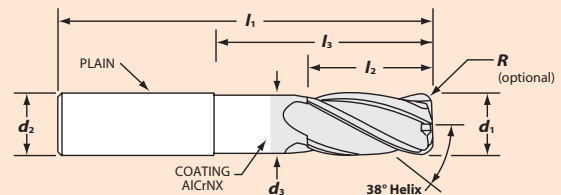

in $d_1: +0.000 / -0.002$ $d_2: h_6$
mm $d_1: +0,000 / -0,050$ $d_2: h_6$

GOT LBS?

Getting the right flute and neck length is easy with IMCO's M924N end mills.

Use either the M924N 1xD or 2xD with short neck relief to get the LOF and OAL that you require when you need a long reach but a necked shank isn't critical.

Use either the M924N 1xD or 2xD with long neck relief to get the clearance necessary to machine your part when working in deep cavities and a necked shank is necessary.

Model Code: M924N

2xD w/Corner Radius and Short Neck Relief

Cutter Dia d1	Shank Dia d2	Length of Cut l2	Overall Length l1	Reach LBS l3	Neck Dia d3	Order Code by Corner Radius (R) (replace -xxx in EZ-ID number with decimal size below)				EZ-ID Number M924-xxx-xxx-xxx-Lxxx d1 l2 R l1				
						.015 CR	.030 CR	.060 CR	.090 CR					
1/8	1/8	1/4	2-1/2	3/8	.118	67562								
3/16	3/16	3/8	3	1/2	.176	67564	67565							M924-0187-0375-N0250-xxx
1/4	1/4	1/2	3	5/8	.235	67571	67572	67573						M924-0250-0500-N0625-xxx
			4	5/8	.235	67575	67576	67577						M924-0250-0500-N0625-xxx-L4
3/8	3/8	3/4	4	1	.355	68698	68699	68700						M924-0375-0750-N1000-xxx
			5	1	.355	68701	68702	68703						M924-0375-0750-N1000-xxx-L5
			6	1	.355	68704	68705	68706						M924-0375-0750-N1000-xxx-L6
1/2	1/2	1	4	1-1/4	.475		67689	67690	67691					M924-0500-1000-N1250-xxx
			5	1-1/4	.475		67692	67693	67694					M924-0500-1000-N1250-xxx-L5
			6	1-1/4	.475		67695	67696	67697					M924-0500-1000-N1250-xxx-L6
5/8	5/8	1-1/4	4	1-1/2	.590		67698	67699	67700					M924-0625-1250-N1500-xxx
			5	1-1/2	.590		67701	67702	67703					M924-0625-1250-N1500-xxx-L5
			6	1-1/2	.590		67704	67705	67706					M924-0625-1250-N1500-xxx-L6
3/4	3/4	1-1/2	5	1-3/4	.715		67707	67708	67709					M924-0750-1500-N1750-xxx
			6	1-3/4	.715		67710	67711	67712					M924-0750-1500-N1750-xxx-L6
			7	1-3/4	.715		67713	67714	67715					M924-0750-1500-N1750-xxx-L7
1	1	2	5	2-1/4	.960		67716	67717	67718					M924-1000-2000-N2250-xxx
			6	2-1/4	.960		67719	67720	67721					M924-1000-2000-N2250-xxx-L6
			7	2-1/4	.960		67722	67723	67724					M924-1000-2000-N2250-xxx-L7
1-1/4	1-1/4	2-1/2	6	2-3/4	1.210		67725	67726	67727					M924-1250-2500-N2750-xxx
			8	2-3/4	1.210		67728	67729	67730					M924-1250-2500-N2750-xxx-L8

Model Code: M924N

2xD w/Corner Radius and Short Neck Relief

Cutter Dia d1	Shank Dia d2	Length of Cut l2	Overall Length l1	Reach LBS l3	Neck Dia d3	Order Code by Corner Radius (R) (replace -xxx in EZ-ID number with mm size below)		EZ-ID Number M924-xxx-xxx-xxx-Lxxx d1 l2 R l1						
						0,5 CR	1,0 CR							
6	6	12	75	18	5,4	68537							M924-060-012-N018-xxx	
			100	18	5,4	68538								M924-060-012-N018-xxx-L100
8	8	16	75	22	7,4	68539							M924-080-016-N022-xxx	
			100	22	7,4	68540								M924-080-016-N022-xxx-L100
10	10	20	72	26	9,3	68580	68581						M924-100-020-N026-xxx	
			100	26	9,3	68582	68583							M924-100-020-N026-xxx-L100
			150	26	9,3	68584	68585							M924-100-020-N026-xxx-L150
12	12	24	83	30	11,2	68586	68587							M924-120-024-N030-xxx
			100	30	11,2	68588	68589							M924-120-024-N030-xxx-L100
			125	30	11,2	68590	68591							M924-120-024-N030-xxx-L125
			150	30	11,2	68592	68593							M924-120-024-N030-xxx-L150
16	16	32	110	38	15	68594	68595						M924-160-032-N038-xxx	
			150	38	15	68596	68597							M924-160-032-N038-xxx-L150
20	20	40	125	46	19	68598	68599						M924-200-040-N046-xxx	
			150	46	19	68600	68601							M924-200-040-N046-xxx-L150
25	25	50	120	56	24	68602	68603						M924-250-050-N056-xxx	
			150	56	24	68604	68605							M924-250-050-N056-xxx-L150

Model Code: M924N 2xD w/Corner Radius and Long Neck Relief

Cutter Dia d1	Shank Dia d2	Length of Cut l2	Overall Length l1	Reach LBS l3	Neck Dia d3	Order Code by Corner Radius (R) (replace -xxx in EZ-ID number with decimal size below)				EZ-ID Number M924-xxx-xxx-xxx-Lxxx				
						.015 CR	.030 CR	.060 CR	.090 CR	d1	l2	R	l1	
1/8	1/8	1/4	2-1/2	1-1/8	.118	67731								M924-0125-0250-N1125-xxx
3/16	3/16	3/8	3	1-3/8	.176	67733	67734							M924-0187-0375-N1375-xxx
1/4	1/4	1/2	3	1-3/8	.235	67740	67741	67742						M924-0250-0500-N1375-xxx
			4	2-3/8	.235	67744	67745	67746						M924-0250-0500-N2375-xxx-L4
3/8	3/8	3/4	4	2-3/8	.355	68324	68325	68326						M924-0375-0750-N2375-xxx
			5	3-3/8	.355	68327	68328	68329						M924-0375-0750-N3375-xxx-L5
			6	4-3/8	.355	68330	68331	68332						M924-0375-0750-N4375-xxx-L6
1/2	1/2	1	4	2-1/4	.475		67858	67859	67860					M924-0500-1000-N2250-xxx
			5	3-1/4	.475		67861	67862	67863					M924-0500-1000-N3250-xxx-L5
			6	4-1/4	.475		67864	67865	67866					M924-0500-1000-N4250-xxx-L6
5/8	5/8	1-1/4	4	2-1/8	.590		67867	67868	67869					M924-0625-1250-N2125-xxx
			5	3-1/8	.590		67870	67871	67872					M924-0625-1250-N3125-xxx-L5
			6	4-1/8	.590		67873	67874	67875					M924-0625-1250-N4125-xxx-L6
3/4	3/4	1-1/2	5	2-7/8	.715		67876	67877	67878					M924-0750-1500-N2875-xxx
			6	3-7/8	.715		67879	67880	67881					M924-0750-1500-N3875-xxx-L6
			7	4-7/8	.715		67882	67883	67884					M924-0750-1500-N4875-xxx-L7
1	1	2	5	2-5/8	.960		67885	67886	67887					M924-1000-2000-N2625-xxx
			6	3-5/8	.960		67888	67889	67890					M924-1000-2000-N3625-xxx-L6
			7	4-5/8	.960		67891	67892	67893					M924-1000-2000-N4625-xxx-L7
1-1/4	1-1/4	2-1/2	6	3-5/8	1.210		67894	67895	67896					M924-1250-2500-N3625-xxx
			8	5-5/8	1.210		67897	67898	67899					M924-1250-2500-N5625-xxx-L8

Model Code: M924N 2xD w/Corner Radius and Long Neck Relief

Cutter Dia d1	Shank Dia d2	Length of Cut l2	Overall Length l1	Reach LBS l3	Neck Dia d3	Order Code by Corner Radius (R) (replace -xxx in EZ-ID number with mm size below)		EZ-ID Number M924-xxx-xxx-xxx-Lxxx					
						0,5 CR	1,0 CR	d1	l2	R	l1		
6	6	12	75	39	5,4	68020						M924-060-012-N039-xxx	
			100	64	5,4	68021							M924-060-012-N064-xxx-L100
8	8	16	75	39	7,4	68023						M924-080-016-N039-xxx	
			100	64	7,4	68024							M924-080-016-N064-xxx-L100
10	10	20	72	32	9,3	68070	68071					M924-100-020-N032-xxx	
			100	60	9,3	68072	68073						M924-100-020-N060-xxx-L100
			150	110	9,3	68074	68075						M924-100-020-N110-xxx-L150
12	12	24	83	38	11,2	68076	68077					M924-120-024-N038-xxx	
			100	55	11,2	68078	68079						M924-120-024-N055-xxx-L100
			125	80	11,2	68080	68081						M924-120-024-N080-xxx-L125
			150	105	11,2	68082	68083						M924-120-024-N105-xxx-L150
16	16	32	110	62	15	68084	68085					M924-160-032-N062-xxx	
			150	102	15	68086	68087						M924-160-032-N102-xxx-L150
20	20	40	125	75	19	68088	68089					M924-200-040-N075-xxx	
			150	100	19	68090	68091						M924-200-040-N100-xxx-L150
25	25	50	120	64	24	68092	68093					M924-250-050-N064-xxx	
			150	94	24	68094	68095						M924-250-050-N094-xxx-L150

Model Code: M924N

1xD w/Corner Radius and Short Neck Relief P

Cutter Dia d1	Shank Dia d2	Length of Cut l2	Overall Length l1	Reach LBS l3	Neck Dia d3	Order Code by Corner Radius (R) (replace -xxx in EZ-ID number with decimal size below)					EZ-ID Number M924-xxx-xxx-xxx-Lxxx d1 l2 R l1
						.015 CR	.030 CR	.060 CR	.090 CR	.120 CR	
3/8	3/8	1/2	3	3/4	.355	67579	67580	67581	67582		M924-0375-0500-N0750-xxx
			4	3/4	.355	67584	67585	67586	67587		M924-0375-0500-N0750-xxx-L4
			5	3/4	.355	67589	67590	67591	67592		M924-0375-0500-N0750-xxx-L5
			6	3/4	.355	67594	67595	67596	67597		M924-0375-0500-N0750-xxx-L6
1/2	1/2	5/8	3	7/8	.475		67599	67600	67601	67602	M924-0500-0625-N0875-xxx
			4	7/8	.475		67604	67605	67606	67607	M924-0500-0625-N0875-xxx-L4
			5	7/8	.475		67609	67610	67611	67612	M924-0500-0625-N0875-xxx-L5
			6	7/8	.475		67614	67615	67616	67617	M924-0500-0625-N0875-xxx-L6
5/8	5/8	3/4	4	1	.590		67619	67620	67621	67622	M924-0625-0750-N1000-xxx
			5	1	.590		67624	67625	67626	67627	M924-0625-0750-N1000-xxx-L5
			6	1	.590		67629	67630	67631	67632	M924-0625-0750-N1000-xxx-L6
3/4	3/4	1	4	1-1/4	.715		67634	67635	67636	67637	M924-0750-1000-N1250-xxx
			5	1-1/4	.715		67639	67640	67641	67642	M924-0750-1000-N1250-xxx-L5
			6	1-1/4	.715		67644	67645	67646	67647	M924-0750-1000-N1250-xxx-L6
			7	1-1/4	.715		67649	67650	67651	67652	M924-0750-1000-N1250-xxx-L7
1	1	1-1/4	4	1-1/2	.960		67654	67655	67656	67657	M924-1000-1250-N1500-xxx
			5	1-1/2	.960		67659	67660	67661	67662	M924-1000-1250-N1500-xxx-L5
			6	1-1/2	.960		67664	67665	67666	67667	M924-1000-1250-N1500-xxx-L6
			7	1-1/2	.960		67669	67670	67671	67672	M924-1000-1250-N1500-xxx-L7
1-1/4	1-1/4	1-1/2	4-1/2	1-3/4	1.210		67674	67675	67676	67677	M924-1250-1500-N1750-xxx
			6	1-3/4	1.210		67679	67680	67681	67682	M924-1250-1500-N1750-xxx-L6
			8	1-3/4	1.210		67684	67685	67686	67687	M924-1250-1500-N1750-xxx-L8

Model Code: M924N

1xD w/Corner Radius and Short Neck Relief P

Cutter Dia d1	Shank Dia d2	Length of Cut l2	Overall Length l1	Reach LBS l3	Neck Dia d3	Order Code by Corner Radius (R) (replace -xxx in EZ-ID number with mm size below)			EZ-ID Number M924-xxx-xxx-xxx-Lxxx d1 l2 R l1
						0,5 CR	1,0 CR	1,5 CR	
10	10	12	72	18	9,3	68541	68542		M924-100-012-N018-xxx
			100	18	9,3	68543	68544		M924-100-012-N018-xxx-L100
			150	18	9,3	68545	68546		M924-100-012-N018-xxx-L150
12	12	15	83	21	11,2	68547	68548	68549	M924-120-015-N021-xxx
			100	21	11,2	68550	68551	68552	M924-120-015-N021-xxx-L100
			125	21	11,2	68553	68554	68555	M924-120-015-N021-xxx-L125
			150	21	11,2	68556	68557	68558	M924-120-015-N021-xxx-L150
16	16	20	110	26	15	68559	68560	68561	M924-160-016-N026-xxx
			150	26	15	68562	68563	68564	M924-160-016-N026-xxx-L150
20	20	25	100	31	19	68565	68566	68567	M924-200-025-N031-xxx
			125	31	19	68568	68569	68570	M924-200-025-N031-xxx-L125
			150	31	19	68571	68572	68573	M924-200-025-N031-xxx-L150
25	25	32	120	38	24	68574	68575	68576	M924-250-032-N038-xxx
			150	38	24	68577	68578	68579	M924-250-032-N038-xxx-L150

Model Code: M924N 1xD w/Corner Radius and Long Neck Relief

Cutter Dia d1	Shank Dia d2	Length of Cut l2	Overall Length l1	Reach LBS l3	Neck Dia d3	Order Code by Corner Radius (R) (replace -xxx in EZ-ID number with decimal size below)					EZ-ID Number M924-xxx-xxx-xxx-Lxxx d1 l2 R l1
						.015 CR	.030 CR	.060 CR	.090 CR	.120 CR	
3/8	3/8	1/2	3	1-3/8	.355	67748	67749	67750	67751		M924-0375-0500-N1375-xxx
			4	2-3/8	.355	67753	67754	67755	67756		M924-0375-0500-N2375-xxx-L4
			5	3-3/8	.355	67758	67759	67760	67761		M924-0375-0500-N3375-xxx-L5
			6	4-3/8	.355	67763	67764	67765	67766		M924-0375-0500-N4375-xxx-L6
1/2	1/2	5/8	3	1-3/8	.475		67768	67769	67770	67771	M924-0500-0625-N1375-xxx
			4	2-1/4	.475		67773	67774	67775	67776	M924-0500-0625-N2250-xxx-L4
			5	3-1/4	.475		67778	67779	67780	67781	M924-0500-0625-N3250-xxx-L5
			6	4-1/4	.475		67783	67784	67785	67786	M924-0500-0625-N4250-xxx-L6
5/8	5/8	3/4	4	2-1/8	.590		67788	67789	67790	67791	M924-0625-0750-N2125-xxx
			5	3-1/8	.590		67793	67794	67795	67796	M924-0625-0750-N3125-xxx-L5
			6	4-1/8	.590		67798	67799	67800	67801	M924-0625-0750-N4125-xxx-L6
3/4	3/4	1	4	2	.715		67803	67804	67805	67806	M924-0750-1000-N2000-xxx
			5	2-7/8	.715		67808	67809	67810	67811	M924-0750-1000-N2875-xxx-L5
			6	3-7/8	.715		67813	67814	67815	67816	M924-0750-1000-N3875-xxx-L6
			7	4-7/8	.715		67818	67819	67820	67821	M924-0750-1000-N4875-xxx-L7
1	1	1-1/4	4	2-1/4	.960		67823	67824	67825	67826	M924-1000-1250-N2250-xxx
			5	2-5/8	.960		67828	67829	67830	67831	M924-1000-1250-N2625-xxx-L5
			6	3-5/8	.960		67833	67834	67835	67836	M924-1000-1250-N3625-xxx-L6
			7	4-5/8	.960		67838	67839	67840	67841	M924-1000-1250-N4625-xxx-L7
1-1/4	1-1/4	1-1/2	4-1/2	2-1/2	1.210		67843	67844	67845	67846	M924-1250-1500-N2250-xxx
			6	3-5/8	1.210		67848	67849	67850	67851	M924-1250-1500-N3625-xxx-L6
			8	5-5/8	1.210		67853	67854	67855	67856	M924-1250-1500-N5625-xxx-L8

Model Code: M924N 1xD w/Corner Radius and Long Neck Relief

Cutter Dia d1	Shank Dia d2	Length of Cut l2	Overall Length l1	Reach LBS l3	Neck Dia d3	Order Code by Corner Radius (R) (replace -xxx in EZ-ID number with mm size below)			EZ-ID Number M924-xxx-xxx-Nxxx-xxx-Lxxx d1 l2 l3 R l1
						0,5 CR	1,0 CR	1,5 CR	
10	10	12	72	32	9,3	68025	68026		M924-100-012-N032-xxx
			100	60	9,3	68027	68028		M924-100-012-N060-xxx-L100
			150	110	9,3	68029	68030		M924-100-012-N110-xxx-L150
12	12	15	83	38	11,2	68031	68032	68033	M924-120-015-N038-xxx
			100	55	11,2	68034	68035	68036	M924-120-015-N055-xxx-L100
			125	80	11,2	68037	68038	68039	M924-120-015-N080-xxx-L125
			150	105	11,2	68040	68041	68042	M924-120-015-N105-xxx-L150
16	16	20	110	62	15	68043	68044	68045	M924-160-016-N062-xxx
			150	102	15	68046	68047	68048	M924-160-016-N102-xxx-L150
20	20	25	100	50	19	68049	68050	68051	M924-200-025-N050-xxx
			125	75	19	68052	68053	68054	M924-200-025-N075-xxx-L125
			150	100	19	68055	68056	68057	M924-200-025-N100-xxx-L150
25	25	32	120	64	24	68058	68059	68060	M924-250-032-N064-xxx
			150	94	24	68061	68062	68063	M924-250-032-N094-xxx-L150

M924

Ball End



The M924B ball end is excellent for contouring applications in a variety of materials. Based on the same high-performance design as the M924 series, but with a full end radius.

As a general rule, when using the M924B ball end mill, reduce feed rates by 25% when the axial DOC exceeds 75% of the mill diameter. Refer to speed and feed information for more detail.

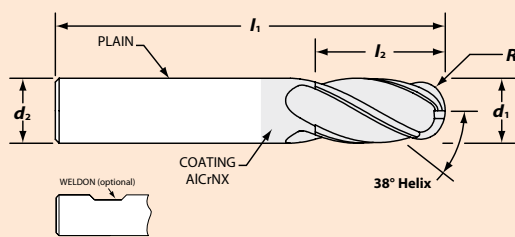

in $d_1: +0,000 / -0,002$ $d_2: h_6$
mm $d_1: +0,000 / -0,050$ $d_2: h_6$

Model Code: M924B w/Ball End and Plain Shank



Cutter Dia d_1	Shank Dia d_2	Length of Cut l_2	Overall Length l_1	Order Code	EZ-ID Number M924-xxxx-xxxx-BN d_1 l_2
1/8	1/8	1/2	1-1/2	67501	M924-0125-0500-BN
5/32	3/16	9/16	2	67540	M924-0156-0562-BN
3/16	3/16	9/16	2	67513	M924-0187-0562-BN
7/32	1/4	3/4	2-1/2	67545	M924-0218-0750-BN
1/4	1/4	3/4	2-1/2	67529	M924-0250-0750-BN
5/16	5/16	13/16	2-1/2	67103	M924-0312-0812-BN
3/8	3/8	7/8	2-1/2	67131	M924-0375-0875-BN
7/16	7/16	1	2-3/4	67195	M924-0437-1000-BN
1/2	1/2	1	3	67221	M924-0500-1000-BN
		1-1/4	3	67230	M924-0500-1250-BN
5/8	5/8	1-3/8	3-1/2	67295	M924-0625-1375-BN
3/4	3/4	1-5/8	4	67365	M924-0750-1625-BN

Model Code: M924B w/Ball End and Weldon Shank



Cutter Dia d_1	Shank Dia d_2	Length of Cut l_2	Overall Length l_1	Order Code	EZ-ID Number M924-xxxx-xxxx-BN-W d_1 l_2
3/8	3/8	7/8	2-1/2	68715	M924-0375-0875-BN-W
1/2	1/2	1	3	68717	M924-0500-1000-BN-W
		1-1/4	3	68718	M924-0500-1250-BN-W
5/8	5/8	1-3/8	3-1/2	68720	M924-0625-1375-BN-W
3/4	3/4	1-5/8	4	68721	M924-0750-1625-BN-W

Model Code: M924B w/Ball End and Plain Shank

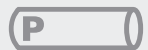

Cutter Dia d_1	Shank Dia d_2	Length of Cut l_2	Overall Length l_1	Plain Shank EDP	EZ-ID Number M924-xxx-xxx-BN-Lxxx d_1 l_2 l_1
3	6	9	50	68010	M924-030-009-BN
4	6	12	54	68011	M924-040-012-BN
5	6	15	54	68012	M924-050-015-BN
6	6	13	57	68013	M924-060-013-BN
8	8	19	63	68014	M924-080-019-BN
10	10	22	72	68015	M924-100-022-BN
12	12	26	83	68016	M924-120-026-BN
16	16	34	92	68017	M924-160-034-BN
20	20	38	104	68018	M924-200-038-BN

M924

Ball End w/Neck Relief



The same high-performance design but with a full end radius and neck relief for additional clearance in cavities and when machining tightly against part walls.

Model Code: M924NB w/Ball End and Short Neck Relief



Cutter Dia d1	Shank Dia d2	Length of Cut l2	Overall Length l1	Reach LBS l3	Neck Dia d3	Plain Shank EDP	EZ-ID Number M924-xxx-xxx-xxx-Lxxx d1 l2 R l1
1/8	1/8	1/4	2-1/2	3/8	.118	67563	M924-0125-0250-N0375-BN
3/16	3/16	3/8	3	1/2	.176	67566	M924-0187-0375-N0500-BN
1/4	1/4	1/2	3	5/8	.235	67574	M924-0250-0500-N0625-BN
			4	5/8	.235	67578	M924-0250-0500-N0625-BN-L4
3/8	3/8	1/2	3	3/4	.355	67583	M924-0375-0500-N0750-BN
			4	3/4	.355	67588	M924-0375-0500-N0750-BN-L4
			5	3/4	.355	67593	M924-0375-0500-N0750-BN-L5
			6	3/4	.355	67598	M924-0375-0500-N0750-BN-L6
1/2	1/2	5/8	3	7/8	.475	67603	M924-0500-0625-N0875-BN
			4	7/8	.475	67608	M924-0500-0625-N0875-BN-L4
			5	7/8	.475	67613	M924-0500-0625-N0875-BN-L5
			6	7/8	.475	67618	M924-0500-0625-N0875-BN-L6
5/8	5/8	3/4	4	1	.590	67623	M924-0625-0750-N1000-BN
			5	1	.590	67628	M924-0625-0750-N1000-BN-L5
			6	1	.590	67633	M924-0625-0750-N1000-BN-L6
3/4	3/4	1	4	1-1/4	.715	67638	M924-0750-1000-N1250-BN
			5	1-1/4	.715	67643	M924-0750-1000-N1250-BN-L5
			6	1-1/4	.715	67648	M924-0750-1000-N1250-BN-L6
			7	1-1/4	.715	67653	M924-0750-1000-N1250-BN-L7
1	1	1-1/4	4	1-1/2	.960	67658	M924-1000-1250-N1500-BN
			5	1-1/2	.960	67663	M924-1000-1250-N1500-BN-L5
			6	1-1/2	.960	67668	M924-1000-1250-N1500-BN-L6
1-1/4	1-1/4	1-1/2	7	1-1/2	.960	67673	M924-1000-1250-N1500-BN-L7
			4-1/2	1-3/4	1.210	67678	M924-1250-1500-N1750-BN
			6	1-3/4	1.210	67683	M924-1250-1500-N1750-BN-L6
			8	1-3/4	1.210	67688	M924-1250-1500-N1750-BN-L8

Model Code: M924NB w/Ball End and Short Neck Relief

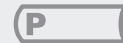

Cutter Dia d1	Shank Dia d2	Length of Cut l2	Overall Length l1	Reach LBS l3	Neck Dia d3	Plain Shank EDP	EZ-ID Number M924-xxx-xxx-xxx-Lxxx d1 l2 R l1
6	6	12	75	18	5,4	68606	M924-060-012-N018-BN
			100	18	5,4	68607	M924-060-012-N018-BN-L100
8	8	16	75	22	7,4	68608	M924-080-016-N022-BN
			100	22	7,4	68609	M924-080-016-N022-BN-L100
10	10	12	72	18	9,3	68610	M924-100-012-N018-BN
			100	18	9,3	68611	M924-100-012-N018-BN-L100
			150	18	9,3	68612	M924-100-012-N018-BN-L150
12	12	15	83	21	11,2	68613	M924-120-015-N021-BN
			100	21	11,2	68614	M924-120-015-N021-BN-L100
			125	21	11,2	68615	M924-120-015-N021-BN-L125
			150	21	11,2	68616	M924-120-015-N021-BN-L150
16	16	20	110	26	15	68617	M924-160-020-N026-BN
			150	26	15	68618	M924-160-020-N026-BN-L150
20	20	25	100	31	19	68619	M924-200-025-N031-BN
			125	31	19	68620	M924-200-025-N031-BN-L125
			150	31	19	68621	M924-200-025-N031-BN-L150
25	25	32	120	38	24	68622	M924-250-032-N038-BN
			150	38	24	68623	M924-250-032-N038-BN-L150

Model Code: M924NB
w/Ball End and Long Neck Relief 

Cutter Dia d1	Shank Dia d2	Length of Cut l2	Overall Length l1	Reach LBS l3	Neck Dia d3	Plain Shank EDP	EZ-ID Number M924-xxx-xxx-xxx-Lxxx d1 l2 R l1
1/8	1/8	1/4	2-1/2	1-1/8	.118	67732	M924-0125-0250-N1125-BN
3/16	3/16	3/8	3	1-3/8	.176	67735	M924-0187-0375-N1375-BN
1/4	1/4	1/2	3	1-3/8	.235	67743	M924-0250-0500-N1375-BN
			4	2-3/8	.235	67747	M924-0250-0500-N2375-BN-L4
3/8	3/8	1/2	3	1-3/8	.355	67752	M924-0375-0500-N1375-BN
			4	2-3/8	.355	67757	M924-0375-0500-N2375-BN-L4
			5	3-3/8	.355	67762	M924-0375-0500-N3375-BN-L5
			6	4-3/8	.355	67767	M924-0375-0500-N4375-BN-L6
1/2	1/2	5/8	3	1-3/8	.475	67772	M924-0500-0625-N1375-BN
			4	2-1/4	.475	67777	M924-0500-0625-N2250-BN-L4
			5	3-1/4	.475	67782	M924-0500-0625-N3250-BN-L5
			6	4-1/4	.475	67787	M924-0500-0625-N4250-BN-L6
5/8	5/8	3/4	4	2-1/8	.590	67792	M924-0625-0750-N2125-BN
			5	3-1/8	.590	67797	M924-0625-0750-N3125-BN-L5
			6	4-1/8	.590	67802	M924-0625-0750-N4125-BN-L6
3/4	3/4	1	4	2	.715	67807	M924-0750-1000-N2000-BN
			5	2-7/8	.715	67812	M924-0750-1000-N2875-BN-L5
			6	3-7/8	.715	67817	M924-0750-1000-N3875-BN-L6
			7	4-7/8	.715	67822	M924-0750-1000-N4875-BN-L7
1	1	1-1/4	4	2-1/4	.960	67827	M924-1000-1250-N2250-BN
			5	2-5/8	.960	67832	M924-1000-1250-N2625-BN-L5
			6	3-5/8	.960	67837	M924-1000-1250-N3625-BN-L6
			7	4-5/8	.960	67842	M924-1000-1250-N4625-BN-L7
1-1/4	1-1/4	1-1/2	4-1/2	2-1/2	1.210	67847	M924-1250-1500-N2500-BN
			6	3-5/8	1.210	67852	M924-1250-1500-N3625-BN-L6
			8	5-5/8	1.210	67857	M924-1250-1500-N5625-BN-L8

Model Code: M924NB
w/Ball End and Long Neck Relief 

Cutter Dia d1	Shank Dia d2	Length of Cut l2	Overall Length l1	Reach LBS l3	Neck Dia d3	Plain Shank EDP	EZ-ID Number M924-xxx-xxx-xxx-Lxxx d1 l2 R l1
6	6	12	75	39	5,4	68097	M924-060-012-N039-BN
			100	64	5,4	68098	M924-060-012-N064-BN-L100
8	8	16	75	39	7,4	68100	M924-080-016-N039-BN
			100	64	7,4	68101	M924-080-016-N064-BN-L100
10	10	12	72	32	9,3	68102	M924-100-012-N032-BN
			100	60	9,3	68103	M924-100-012-N060-BN-L100
			150	110	9,3	68104	M924-100-012-N110-BN-L150
			83	38	11,2	68105	M924-120-015-N038-BN
12	12	15	100	55	11,2	68106	M924-120-015-N055-BN-L100
			125	80	11,2	68107	M924-120-015-N080-BN-L125
			150	105	11,2	68108	M924-120-015-N105-BN-L150
			110	62	15	68109	M924-160-020-N062-BN
16	16	20	150	102	15	68110	M924-160-020-N102-BN-L150
			100	50	19	68111	M924-200-025-N050-BN
20	20	25	125	75	19	68112	M924-200-025-N075-BN-L125
			150	100	19	68113	M924-200-025-N100-BN-L150
			120	64	24	68114	M924-250-032-N064-BN
25	25	32	150	94	24	68115	M924-250-032-N094-BN-L150

TOOL TIP

Higher Metal Removal Rates

One IMCO customer achieved a feed rate more than five times higher with the POW•R•FEED® M9 than with a similar competitor's tool, as tested in the customer's operation in 1020 hot roll steel. POW•R•FEED M9 not only ran smoothly at a higher speed, it also devoured 450% more material, effectively eating the former tool for lunch.

M904

Square End and Corner Radius



Well-known for its power, balance and versatility, IMCO's M904 is designed for high-performance milling in job shop environments where a wide range of materials are used. Unique vibration dampening geometrics reduce chatter and improve tool life. Use square end for general finishing operations, and corner radius for roughing and semi-finishing operations.

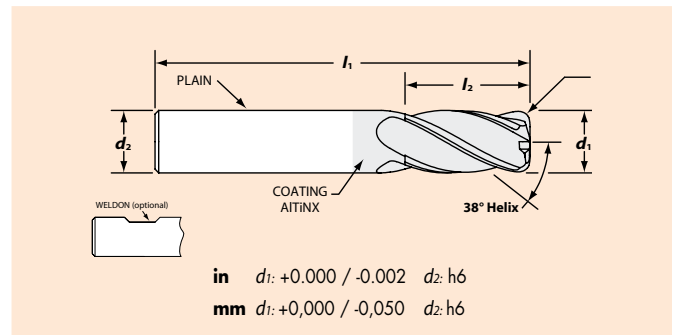

Model Code: M904 w/Square End and Plain Shank

Cutter Dia d1	Shank Dia d2	Length of Cut l2	Overall Length l1	Order Code	EZ-ID Number M904-xxxx-xxxx-SQ d1 l2
1/8	1/8	1/2	1-1/2	63010	M904-0125-0500-SQ
5/32	3/16	9/16	2	63011	M904-0156-0562-SQ
3/16	3/16	5/8	2	63012	M904-0187-0625-SQ
7/32	1/4	5/8	2-1/2	63013	M904-0218-0625-SQ
1/4	1/4	3/8	2	63003	M904-0250-0375-SQ
		3/4	2-1/2	63014	M904-0250-0750-SQ
5/16	5/16	13/16	2-1/2	63016	M904-0312-0812-SQ
3/8	3/8	1/2	2	63004	M904-0375-0500-SQ
		7/8	2-1/2	63018	M904-0375-0875-SQ
7/16	7/16	1	2-3/4	63020	M904-0437-1000-SQ
1/2	1/2	5/8	2-1/2	63005	M904-0500-0625-SQ
		1	3	63022	M904-0500-1000-SQ
		1-1/4	3	63100	M904-0500-1250-SQ
5/8	5/8	3/4	3	63006	M904-0625-0750-SQ
		1-1/4	3-1/2	63024	M904-0625-1250-SQ
3/4	3/4	7/8	3	63007	M904-0750-0875-SQ
		1-1/2	4	63025	M904-0750-1500-SQ
1	1	1-1/2	4	63026	M904-1000-1500-SQ

Model Code: M904 w/Square End and Weldon Shank

Cutter Dia d1	Shank Dia d2	Length of Cut l2	Overall Length l1	Order Code	EZ-ID Number M904-xxxx-xxxx-SQ-W d1 l2
3/8	3/8	7/8	2-1/2	63043	M904-0375-0875-SQ-W
7/16	7/16	1	2-3/4	63044	M904-0437-1000-SQ-W
1/2	1/2	1	3	63045	M904-0500-1000-SQ-W
		1-1/4	3	63101	M904-0500-1250-SQ-W
5/8	5/8	1-1/4	3-1/2	63046	M904-0625-1250-SQ-W
3/4	3/4	1-1/2	4	63047	M904-0750-1500-SQ-W
1	1	1-1/2	4	63048	M904-1000-1500-SQ-W

Model Code: M904 w/Square End and Plain Shank

Cutter Dia d1	Shank Dia d2	Length of Cut l2	Overall Length l1	Order Code	EZ-ID Number M904-xxx-xxx-SQ d1 l2
3	3	8	38	63027	M904-030-008-SQ
4	4	11	50	63028	M904-040-011-SQ
5	5	13	50	63029	M904-050-013-SQ
6	6	10	54	63123	M904-060-010-SQ
		13	57	63030	M904-060-013-SQ
8	8	12	58	63124	M904-080-012-SQ
		19	63	63032	M904-080-019-SQ
10	10	14	66	63125	M904-100-014-SQ
		22	72	63034	M904-100-022-SQ
12	12	16	73	63126	M904-120-016-SQ
		26	83	63036	M904-120-026-SQ
16	16	22	82	63128	M904-160-022-SQ
		32	92	63038	M904-160-032-SQ
20	20	26	92	63130	M904-200-026-SQ
		38	104	63040	M904-200-038-SQ



It's a win-win result at T & S Machine and smiles all around, including Mike Tullos (front, center), Neal Wilson of IMCO (left), Justin Tullos (right), Josh Cochran of JAC (back, left) and James Carter (back, right).

PROFILE:

IMCO Sales Representative

Neal Wilson

IMCO representative Neal Wilson along with Josh Cochran, President of JAC, service T & S Machine, a shop specializing in aerospace, medical and industrial parts. The shop contacted them, looking for a way to reduce cycle time when machining position plates. Using a 1/2" indexable cutter at a .187 depth of cut in A36 hot-rolled steel, T & S was running just 5 in./min. Josh and Neal suggested trying the IMCO POW-R-FEED.®

Results:

Starting at a .375 depth of cut, T & S was able to:

- More than triple the chip load from .002 to .007 ipr.
- More than double the SFM from 200 to 400.
- Increase tool life 300% – 100 parts vs. 25 parts with the indexable. Time spent indexing inserts was eliminated, too, resulting in more uptime.
- Reduce the cycle time from 45 minutes to 25.

Model Code: M904 w/Corner Radius and Plain Shank

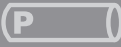

Cutter Dia d1	Shank Dia d2	Length of Cut l2	Overall Length l1	Order Code by Corner Radius (R) (replace -xxx in EZ-ID number with decimal size below)					EZ-ID Number M924-xxx-xxx-xxx		
				.015 CR	.020 CR	.030 CR	.060 CR	.125 CR	d1	l2	R

1/8	1/8	1/4	1-1/2	63248							M904-0125-0250-xxx
		1/2	1-1/2	63064							M904-0125-0500-xxx
5/32	3/16	9/16	2	63118							M904-0156-0562-xxx
3/16	3/16	5/16	2	63249							M904-0187-0312-xxx
		5/8	2	63065							M904-0187-0625-xxx
7/32	1/4	5/8	2-1/2		63119						M904-0218-0625-xxx
1/4	1/4	3/8	2	63058							M904-0250-0375-xxx
		3/4	2-1/2	63066	63466						M904-0250-0750-xxx
		1-1/8	3	63420							M904-0250-1125-xxx
		1-1/2	4	63425							M904-0250-1500-xxx
5/16	5/16	13/16	2-1/2	63067						M904-0312-0812-xxx	
3/8	3/8	1/2	2	63059							M904-0375-0500-xxx
		7/8	2-1/2	63068	63390						M904-0375-0875-xxx
		1-1/8	3	63421							M904-0375-1125-xxx
		1-3/4	4	63426							M904-0375-1750-xxx
7/16	7/16	1	2-3/4	63069						M904-0437-1000-xxx	
1/2	1/2	5/8	2-1/2			63060					M904-0500-0625-xxx
		1	3			63070					M904-0500-1000-xxx
		1-1/4	3			63098	63391	63393			M904-0500-1250-xxx
		2	4			63422					M904-0500-2000-xxx
		2-1/2	5			63427					M904-0500-2500-xxx
		3	6			63430					M904-0500-3000-xxx
5/8	5/8	3/4	3			63061					M904-0625-0750-xxx
		1-1/4	3-1/2			63071	63394				M904-0625-1250-xxx
3/4	3/4	7/8	3			63062					M904-0750-0875-xxx
		1-1/2	4			63072	63395	63397			M904-0750-1500-xxx
		2-1/4	5			63423					M904-0750-2250-xxx
		3	6			63428					M904-0750-3000-xxx
1	1	1-1/2	4			63073	63398				M904-1000-1500-xxx
		3	6			63429					M904-1000-3000-xxx
		4-1/8	7			63432					M904-1000-4125-xxx



TOOL TIP

Run Wet or Dry?

Carbon and tool steels machine well when running dry with an air blast. Consider keeping the coolant on when machining stainless steels, aluminum and super alloys. Running dry requires using a heat-resistant coating (such as AlCrNX) and an air blast to remove chips from the cutting zone. Running dry also eliminates environmental hazards associated with coolant use and disposal.

Model Code: M904 w/Corner Radius and Weldon Shank

Cutter Dia d1	Shank Dia d2	Length of Cut l2	Overall Length l1	Order Code by Corner Radius (R) (replace -xxx in EZ-ID number with decimal size below)				EZ-ID Number M924-xxx-xxx-xxx d1 l2 R
				.020 CR	.030 CR	.060 CR	.125 CR	
3/8	3/8	7/8	2-1/2	63083	63400			M904-0375-0875-xxx-W
7/16	7/16	1	2-3/4	63084				M904-0437-1000-xxx-W
1/2	1/2	1	3		63085			M904-0500-1000-xxx-W
		1-1/4	3		63099	63401	63403	M904-0500-1250-xxx-W
5/8	5/8	1-1/4	3-1/2		63086	63404		M904-0625-1250-xxx-W
3/4	3/4	1-1/2	4		63087	63405	63407	M904-0750-1500-xxx-W
1	1	1-1/2	4		63088	63408		M904-1000-1500-xxx-W

Model Code: M904 w/Corner Radius and Plain Shank

Cutter Dia d1	Shank Dia d2	Length of Cut l2	Overall Length l1	Order Code by Corner Radius (R) (replace -xxx in EZ-ID number with mm size below)				EZ-ID Number M924-xxx-xxx-xxx d1 l2 R
				0,3 CR	0,5 CR	0,75 CR	1,0 CR	
3	3	8	38	63102				M904-030-008-xxx
4	4	11	50	63103				M904-040-011-xxx
5	5	13	50	63104				M904-050-013-xxx
6	6	10	54	63108				M904-060-010-xxx
		13	57	63074	63434			M904-060-013-xxx
		28	75		63455			M904-060-028-xxx
8	8	12	58		63109			M904-080-012-xxx
		19	63	63435	63075			M904-080-019-xxx
		29	75		63456			M904-080-029-xxx
10	10	14	66		63110			M904-100-014-xxx
		22	72	63436	63076			M904-100-022-xxx
		36	88		63457			M904-100-036-xxx
12	12	16	73				63111	M904-120-016-xxx
		26	83		63437	63438	63077	M904-120-026-xxx
		45	100			63458		M904-120-045-xxx
16	16	22	82				63113	M904-160-022-xxx
		32	92			63439	63079	M904-160-032-xxx
		56	125				63459	M904-160-056-xxx
20	20	26	92				63115	M904-200-026-xxx
		38	104			63440	63081	M904-200-038-xxx
		56	125				63460	M904-200-056-xxx

THE EXPERT PROBLEM SOLVER

Your IMCO representative is an expert problem solver and your best resource for technical advice on reducing tool costs, beefing up productivity and making sure you're getting optimum output from every machining station. It's your money. Get the best performance for every dollar by using IMCO tools and the technical advice of your IMCO representative.

PROFILE:

IMCO Sales Representative

Sam Turner

After more than 40 years in the business, Sam Turner really knows his stuff. He regularly solves problems for machining operations throughout the Carolinas and Virginia.

One of Sam's customers, a high-end rifle manufacturer, said they were looking for better tooling to reduce cycle time. They talked to the right man. The shop was slotting in 17-4 stainless, taking four passes at a .093 depth of cut with a .250 radial width of cut. The 3-flute end mill they were using had to be replaced every other day. If they couldn't increase production on the existing machine, they'd have to purchase a new machining center to keep up with production, an expense they would rather avoid. Sam had them test a POW•R•FEED® M904 at higher rpm.



Clint Bakeu (left), Jarrett Rifles shop supervisor, checks components for precise specifications; IMCO representative Sam Turner shows the finished product.



Kenny Jarrett, owner of Jarrett Rifles, knows true quality when he sees it.

The results:

- **IPM increased by 141%.**
- **Cycle time dropped significantly.**
- **Parts per tool couldn't be calculated because, 30 days later, they were still waiting for the POW•R•FEED tool to wear out.**

M904

Ball End



The M904B ball end is excellent for contouring applications in a variety of materials. The same high-performance design, but with a full end radius.

As a general rule, when using the M904B ball end mill, reduce feed rates by 25% when the axial DOC exceeds 75% of the mill diameter. Refer to speed and feed information for more detail.

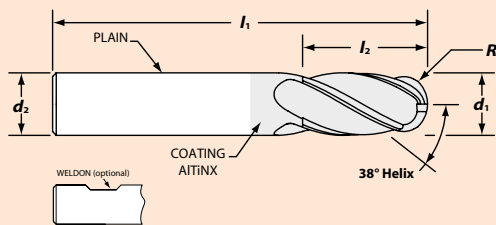

in $d_1: +0.000 / -0.002$ $d_2: h_6$
mm $d_1: +0.000 / -0.050$ $d_2: h_6$

Model Code: M904B w/Ball End and Plain Shank

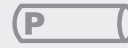

Cutter Dia d1	Shank Dia d2	Length of Cut l2	Overall Length l1	Order Code	EZ-ID Number M904-xxxx-xxxx-BN d1 l2
1/8	1/8	1/2	1-1/2	63139	M904-0125-0500-BN
3/16	3/16	5/8	2	63142	M904-0187-0625-BN
1/4	1/4	3/4	2-1/2	63144	M904-0250-0750-BN
3/8	3/8	7/8	2-1/2	63148	M904-0375-0875-BN
1/2	1/2	1	3	63152	M904-0500-1000-BN
		1-1/4	3	63153	M904-0500-1250-BN
3/4	3/4	1-1/2	4	63156	M904-0750-1500-BN

Model Code: M904B w/Ball End and Weldon Shank



Cutter Dia d1	Shank Dia d2	Length of Cut l2	Overall Length l1	Order Code	EZ-ID Number M904-xxxx-xxxx-BN-W d1 l2
3/8	3/8	7/8	2-1/2	63176	M904-0375-0875-BN-W
1/2	1/2	1	3	63180	M904-0500-1000-BN-W
		1-1/4	3	63181	M904-0500-1250-BN-W
3/4	3/4	1-1/2	4	63184	M904-0750-1500-BN-W

Model Code: M904B w/Ball End and Plain Shank

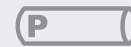

Cutter Dia d1	Shank Dia d2	Length of Cut l2	Overall Length l1	Order Code	EZ-ID Number M904-xxx-xxx-BN d1 l2
3	3	8	38	63160	M904-030-008-BN
4	4	11	50	63161	M904-040-011-BN
5	5	13	50	63162	M904-050-013-BN
6	6	13	57	63163	M904-060-013-BN
8	8	19	63	63165	M904-080-019-BN
10	10	22	72	63167	M904-100-022-BN
12	12	26	83	63169	M904-120-026-BN
16	16	32	92	63171	M904-160-032-BN
20	20	38	104	63173	M904-200-038-BN

M924 and M904 Application Guide (inch) • Speed & Feed

ISO Classification	Work Material	Type of Cut	Axial DOC	Radial DOC	Number of Flutes	Speed (SFM)	Feed (Inches per Tooth)						
							1/8	1/4	3/8	1/2	5/8	3/4	1
K	Cast Iron Gray	Slotting	1 x D	1 x D	4	325	.0006	.0012	.0018	.0024	.0030	.0036	.0048
		Peripheral - Rough	1.25 x D	.5 x D	4	400	.0008	.0015	.0023	.0030	.0038	.0045	.0060
		Peripheral - HEM	2 x D	.15 x D	4	500	.0013	.0026	.0039	.0053	.0066	.0079	.0105
		Finish	1.5 x D	.015 x D	4	475	.0008	.0017	.0025	.0033	.0042	.0050	.0067
	Cast Iron Ductile	Slotting	1 x D	1 x D	4	300	.0005	.0011	.0016	.0022	.0027	.0032	.0043
		Peripheral - Rough	1.25 x D	.5 x D	4	375	.0007	.0014	.0020	.0027	.0034	.0041	.0054
		Peripheral - HEM	2 x D	.15 x D	4	475	.0011	.0022	.0033	.0044	.0055	.0066	.0088
		Finish	1.5 x D	.015 x D	4	450	.0007	.0015	.0022	.0030	.0037	.0045	.0060
	Cast Iron Malleable	Slotting	.75 x D	1 x D	4	250	.0005	.0011	.0016	.0022	.0027	.0032	.0043
		Peripheral - Rough	1.25 x D	.5 x D	4	325	.0007	.0014	.0020	.0027	.0034	.0041	.0054
		Peripheral - HEM	2 x D	.15 x D	4	425	.0011	.0022	.0033	.0044	.0055	.0066	.0088
		Finish	1.5 x D	.015 x D	4	400	.0007	.0015	.0022	.0030	.0037	.0045	.0060
P	Low Carbon Steel 1018, 12L14, 8620	Slotting	1 x D	1 x D	4	350	.0006	.0013	.0019	.0026	.0032	.0038	.0051
		Peripheral - Rough	1.25 x D	.5 x D	4	425	.0008	.0016	.0024	.0032	.0040	.0048	.0064
		Peripheral - HEM	2 x D	.15 x D	4	525	.0015	.0031	.0046	.0061	.0077	.0092	.0123
		Finish	1.5 x D	.015 x D	4	500	.0009	.0018	.0027	.0036	.0044	.0053	.0071
	Medium Carbon Steels 4140, 4340	Slotting	1 x D	1 x D	4	300	.0006	.0012	.0018	.0024	.0030	.0036	.0048
		Peripheral - Rough	1.25 x D	.5 x D	4	375	.0008	.0015	.0023	.0030	.0038	.0045	.0060
		Peripheral - HEM	2 x D	.15 x D	4	475	.0014	.0028	.0042	.0056	.0070	.0084	.0112
		Finish	1.5 x D	.015 x D	4	450	.0008	.0017	.0025	.0033	.0042	.0050	.0067
	Martensitic Stainless Steel 416, 410, 440C	Slotting	.75 x D	1 x D	4	300	.0006	.0012	.0018	.0024	.0029	.0035	.0047
		Peripheral - Rough	1.25 x D	.3 x D	4	375	.0007	.0015	.0022	.0029	.0037	.0044	.0059
		Peripheral - HEM	2 x D	.15 x D	4	475	.0014	.0028	.0042	.0056	.0070	.0084	.0112
		Finish	1.5 x D	.015 x D	4	450	.0007	.0015	.0022	.0030	.0037	.0045	.0060
H	Tool & Die Steels < 48 Rc A2, D2, H13, P20	Slotting	.75 x D	1 x D	4	300	.0006	.0012	.0018	.0024	.0029	.0035	.0047
		Peripheral - Rough	1.25 x D	.3 x D	4	375	.0007	.0015	.0022	.0029	.0037	.0044	.0059
		Peripheral - HEM	2 x D	.15 x D	4	475	.0012	.0024	.0035	.0047	.0059	.0071	.0095
		Finish	1.5 x D	.015 x D	4	450	.0007	.0015	.0022	.0030	.0037	.0045	.0060
M	Austenitic Stainless Steels 303, 304, 316	Slotting	.75 x D	1 x D	4	275	.0007	.0013	.0020	.0026	.0033	.0039	.0052
		Peripheral - Rough	1.25 x D	.3 x D	4	325	.0008	.0016	.0025	.0033	.0041	.0049	.0065
		Peripheral - HEM	2 x D	.1 x D	4	425	.0016	.0031	.0047	.0063	.0078	.0094	.0125
		Finish	1.5 x D	.015 x D	4	400	.0008	.0017	.0025	.0033	.0042	.0050	.0067
	Precipitation Hardening Stainless Steels 17-4 PH, 15-5 PH, 13-8 PH	Slotting	.5 x D	1 x D	4	250	.0005	.0010	.0015	.0020	.0025	.0030	.0040
		Peripheral - Rough	1.25 x D	.3 x D	4	300	.0006	.0013	.0019	.0025	.0031	.0038	.0050
		Peripheral - HEM	1.5 x D	.1 x D	4	400	.0013	.0026	.0039	.0052	.0065	.0078	.0104
		Finish	1.5 x D	.015 x D	4	375	.0006	.0013	.0019	.0026	.0032	.0038	.0051
S	Titanium Alloys	Slotting	.5 x D	1 x D	4	250	.0005	.0010	.0015	.0020	.0025	.0030	.0040
		Peripheral - Rough	1.25 x D	.3 x D	4	300	.0006	.0013	.0019	.0025	.0031	.0038	.0050
		Peripheral - HEM	1.5 x D	.1 x D	4	400	.0012	.0024	.0036	.0048	.0060	.0072	.0096
		Finish	1.5 x D	.015 x D	4	375	.0006	.0013	.0019	.0026	.0032	.0038	.0051
	High Temperature Alloys Inconel, Haynes, Stellite, Hastalloy	Slotting	.25 x D	1 x D	4	60	.0005	.0011	.0016	.0021	.0027	.0032	.0042
		Peripheral - Rough	1.25 x D	.25 x D	4	90	.0007	.0013	.0020	.0027	.0033	.0040	.0053
		Peripheral - HEM	1.5 x D	.1 x D	4	225	.0009	.0018	.0027	.0035	.0044	.0053	.0071
		Finish	1.5 x D	.01 x D	4	125	.0008	.0016	.0023	.0031	.0039	.0047	.0062

D = Tool diameter

Adjustments – Apply these adjustments when programming the following applications.

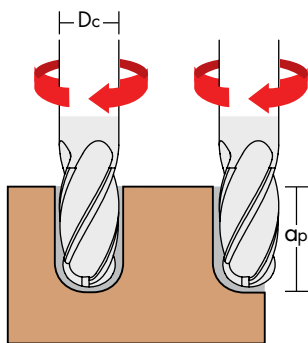

1. Ball nose end mills

- Reduce chip load by 25% from roughing/slotting recommendation when axial DOC (a_p) exceeds 75% of D_c

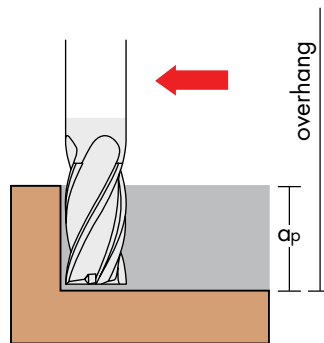

2. Long reach mills with large overhang

- Reduce speed rate and chip load by 20% each when total reach to tool diameter ratio is 5:1 or greater

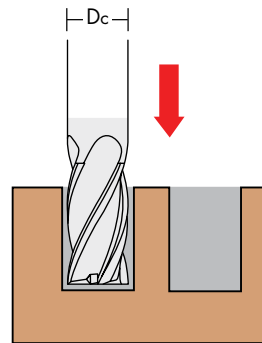

3. Plunge entry into work piece

- Reduce chip load by 80% of recommended slotting rate
- Peck mill if axial DOC (a_p) exceeds 50% of D_c

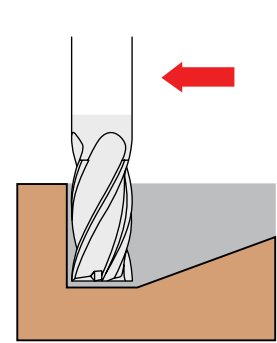

4. Ramp entry into work piece

- Ramp at 1.5°–2.5° angle
- Reduce chip load by 20% of recommended slotting rate

M924 and M904 Application Guide (metric) • Speed & Feed

ISO Classification	Work Material	Type of Cut	Axial DOC	Radial DOC	Number of Flutes	Speed (M/min)	Feed (MM per Tooth)					
							3,0	6,0	10,0	12,0	16,0	20,0
S	Titanium Alloys	Slotting	.5 x D	1 x D	4	76	0.0127	0.0255	0.0423	0.0510	0.0678	0.0846
		Peripheral - Rough	1.25 x D	.3 x D	4	91	0.0159	0.0319	0.0529	0.0637	0.0848	0.1058
		Finish	1.5 x D	.01 x D	4	114	0.0198	0.0396	0.0658	0.0793	0.1054	0.1316
	High Temperature Alloys Inconel, Haynes, Stellite, Hastalloy	Slotting	.25 x D	1 x D	4	18	0.0135	0.0270	0.0448	0.0540	0.0718	0.0896
		Peripheral - Rough	1.25 x D	.25 x D	4	27	0.0169	0.0337	0.0560	0.0675	0.0897	0.1120
		Finish	1.5 x D	.01 x D	4	38	0.0198	0.0396	0.0658	0.0793	0.1054	0.1316
M	Austenitic Stainless Steels 303, 304, 316	Slotting	.75 x D	1 x D	4	84	0.0166	0.0333	0.0552	0.0665	0.0885	0.1104
		Peripheral - Rough	1.25 x D	.3 x D	4	99	0.0208	0.0416	0.0690	0.0831	0.1106	0.1380
		Finish	1.5 x D	.01 x D	4	122	0.0258	0.0517	0.0858	0.1034	0.1375	0.1716
	Precipitation Hardening Stainless Steels 17-4 PH, 15-5 PH, 13-8 PH	Slotting	.5 x D	1 x D	4	76	0.0127	0.0255	0.0423	0.0510	0.0678	0.0846
		Peripheral - Rough	1.25 x D	.3 x D	4	91	0.0159	0.0319	0.0529	0.0637	0.0848	0.1058
		Finish	1.5 x D	.01 x D	4	114	0.0198	0.0396	0.0658	0.0793	0.1054	0.1316
P	Medium Carbon Steels 4140, 4340	Slotting	1 x D	1 x D	4	91	0.0152	0.0305	0.0506	0.0610	0.0811	0.1012
		Peripheral - Rough	1.25 x D	.5 x D	4	114	0.0191	0.0381	0.0632	0.0762	0.1013	0.1265
		Finish	1.5 x D	.01 x D	4	137	0.0258	0.0517	0.0858	0.1034	0.1375	0.1716
	Tool & Die Steels < 48 Rc A2, D2, H13, P20	Slotting	.75 x D	1 x D	4	91	0.0150	0.0299	0.0497	0.0599	0.0796	0.0994
		Peripheral - Rough	1.25 x D	.3 x D	4	114	0.0187	0.0374	0.0621	0.0748	0.0995	0.1242
		Finish	1.5 x D	.01 x D	4	137	0.0233	0.0465	0.0772	0.0930	0.1238	0.1545
	Martensitic Stainless Steel 416, 410, 440C	Slotting	.75 x D	1 x D	4	91	0.0150	0.0299	0.0497	0.0599	0.0796	0.0994
		Peripheral - Rough	1.25 x D	.3 x D	4	114	0.0187	0.0374	0.0621	0.0748	0.0995	0.1242
		Finish	1.5 x D	.01 x D	4	137	0.0233	0.0465	0.0772	0.0930	0.1238	0.1545
K	Cast Iron Gray	Slotting	1 x D	1 x D	4	107	0.0152	0.0305	0.0506	0.0610	0.0811	0.1012
		Peripheral - Rough	1.25 x D	.5 x D	4	137	0.0191	0.0381	0.0632	0.0762	0.1013	0.1265
		Finish	1.5 x D	.01 x D	4	168	0.0258	0.0517	0.0858	0.1034	0.1375	0.1716
	Cast Iron Ductile	Slotting	1 x D	1 x D	4	99	0.0137	0.0274	0.0455	0.0549	0.0730	0.0911
		Peripheral - Rough	1.25 x D	.5 x D	4	130	0.0171	0.0343	0.0569	0.0686	0.0912	0.1138
		Finish	1.5 x D	.01 x D	4	160	0.0233	0.0465	0.0772	0.0930	0.1238	0.1545
	Cast Iron Malleable	Slotting	.75 x D	1 x D	4	91	0.0137	0.0274	0.0455	0.0549	0.0730	0.0911
		Peripheral - Rough	1.25 x D	.5 x D	4	114	0.0171	0.0343	0.0569	0.0686	0.0912	0.1138
		Finish	1.5 x D	.01 x D	4	137	0.0233	0.0465	0.0772	0.0930	0.1238	0.1545

D = Tool diameter

Adjustments – Apply these adjustments when programming the following applications.

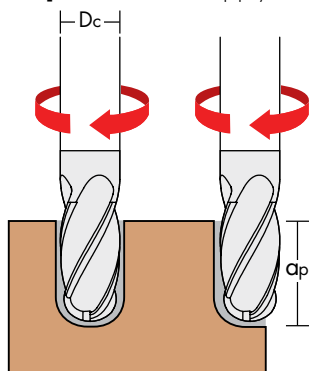

1. Ball nose end mills

- Reduce chip load by 25% from roughing/slotting recommendation when axial DOC (a_p) exceeds 75% of D_c

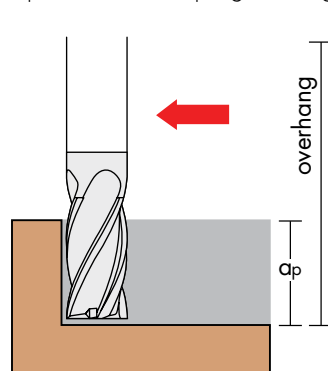

2. Long reach mills with large overhang

- Reduce speed rate and chip load by 20% each when total reach to tool diameter ratio is 5:1 or greater

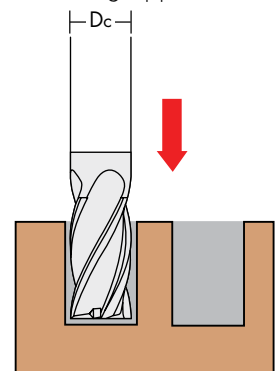

3. Plunge entry into work piece

- Reduce chip load by 80% of recommended slotting rate
- Peck mill if axial DOC (a_p) exceeds 50% of D_c

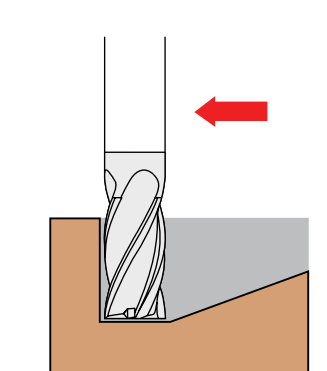

4. Ramp entry into work piece

- Ramp at 1.5°–2.5° angle
- Reduce chip load by 20% of recommended slotting rate

TOOL TIP

Higher Speeds, Higher Feeds

John Lapenta at Champagne Grinding & Manufacturing was starting a new job in 304 stainless and because of the size of the piece he was having a rough go. After consulting his IMCO rep he bumped up the speed, reduced the depth of cut, changed to a different style tool holder and increased the coolant concentration.

Results:

- **33% higher speed**
(surface feet per minute)
- **86% increase in feed rate**
- **Double the chip load per tooth**
- **Smooth machine operation,**
no work stoppage



"We tried Pow•R•Feed in this very difficult job. The tools worked great and we're extremely happy now."

— John Lapenta
Champagne Grinding

M905

Square End and Corner Radius



Go from roughing to a great finish with IMCO's five-flute M905. That extra flute gives you more consistent tool engagement and a better surface finish with every turn.

M905s are based on the same high-performance design as our M904 series. Use square end for general finishing operations, and corner radius for roughing and semi-finishing operations.

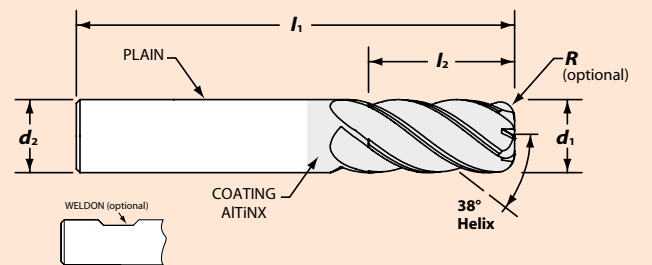

in $d_1: +0.000 / -0.002$ $d_2: h_6$
mm $d_1: +0,000 / -0,050$ $d_2: h_6$

Model Code: M905
w/Square End and Plain Shank (P)

Cutter Dia d1	Shank Dia d2	Length of Cut l2	Overall Length l1	Order Code	EZ-ID Number M905-xxxx-xxxx-SQ d1 l2
1/4	1/4	3/4	2-1/2	63338	M905-0250-0750-SQ
3/8	3/8	7/8	2-1/2	63340	M905-0375-0875-SQ
1/2	1/2	1-1/4	3	63342	M905-0500-1250-SQ
5/8	5/8	1-1/4	3-1/2	63343	M905-0625-1250-SQ
3/4	3/4	1-1/2	4	63344	M905-0750-1500-SQ

Model Code: M905
w/Corner Radius and Plain Shank (P)

Cutter Dia d1	Shank Dia d2	Length of Cut l2	Overall Length l1	Order Code by Corner Radius (R) (replace -xxx in EZ-ID number with decimal size below)			EZ-ID Number M924-xxxx-xxxx-xxx d1 l2 R
				.015 CR	.030 CR	.060 CR	
1/4	1/4	3/4	2-1/2	63287	63462		M905-0250-0750-xxx
3/8	3/8	7/8	2-1/2	63289	63370		M905-0375-0875-xxx
1/2	1/2	1-1/4	3		63291	63371	M905-0500-1250-xxx
5/8	5/8	1-1/4	3-1/2		63292	63374	M905-0625-1250-xxx
3/4	3/4	1-1/2	4		63293	63375	M905-0750-1500-xxx

Model Code: M905
w/Square End and Weldon Shank (W)

Cutter Dia d1	Shank Dia d2	Length of Cut l2	Overall Length l1	Order Code	EZ-ID Number M905-xxxx-xxxx-SQ-W d1 l2
3/8	3/8	7/8	2-1/2	63354	M905-0375-0875-SQ-W
1/2	1/2	1-1/4	3	63356	M905-0500-1250-SQ-W
5/8	5/8	1-1/4	3-1/2	63357	M905-0625-1250-SQ-W
3/4	3/4	1-1/2	4	63358	M905-0750-1500-SQ-W

Model Code: M905
w/Corner Radius and Weldon Shank (W)

Cutter Dia d1	Shank Dia d2	Length of Cut l2	Overall Length l1	Order Code by Corner Radius (R) (replace -xxx in EZ-ID number with decimal size below)			EZ-ID Number M924-xxxx-xxxx-xxx d1 l2 R
				.015 CR	.030 CR	.060 CR	
3/8	3/8	7/8	2-1/2	62976	63380		M905-0375-0875-xxx-W
1/2	1/2	1-1/4	3		62978	63381	M905-0500-1250-xxx-W
5/8	5/8	1-1/4	3-1/2		62980	63384	M905-0625-1250-xxx-W
3/4	3/4	1-1/2	4		62981	63385	M905-0750-1500-xxx-W

Model Code: M905
w/Square End and Plain Shank (P)

Cutter Dia d1	Shank Dia d2	Length of Cut l2	Overall Length l1	Plain Shank EDP	EZ-ID Number M905-xxx-xxx-SQ d1 l2
6	6	13	57	63346	M905-060-013-SQ
8	8	19	63	63347	M905-080-019-SQ
10	10	22	72	63348	M905-100-022-SQ
12	12	26	83	63349	M905-120-026-SQ
16	16	32	92	63350	M905-160-032-SQ
20	20	38	104	63351	M905-200-038-SQ

Model Code: M905
w/Corner Radius and Plain Shank (P)

Cutter Dia d1	Shank Dia d2	Length of Cut l2	Overall Length l1	Order Code by Corner Radius (R) (replace -xxx in EZ-ID number with mm size below)			EZ-ID Number M924-xxxx-xxxx-xxx d1 l2 R
				0,5 CR	1,0 CR	1,5 CR	
6	6	13	57	63295			M905-060-013-050
8	8	19	63	63296			M905-080-019-050
10	10	22	72	63297			M905-100-022-050
12	12	26	83		63298		M905-120-026-075
16	16	32	92			63299	M905-160-032-100
20	20	38	104			63300	M905-200-038-100

NEED MORE SIZES AND CORNER RADII?

The M525 can replace the M905 in most applications. For a greater variety of sizes and corner radii, refer to the enDURO® M525 catalog, available to download at www.imcousa.com.



M905 Application Guide (inch) • Speed & Feed

ISO Classification	Work Material	Type of Cut	Axial DOC	Radial DOC	Number of Flutes	Speed (SFM)	Feed (Inches per Tooth)				
							1/4	3/8	1/2	5/8	3/4
K	Cast Iron Gray	Slotting	.5 x D	1 x D	5	325	.0011	.0016	.0022	.0027	.0032
		Peripheral - Rough	1.25 x D	.3 x D	5	400	.0014	.0020	.0027	.0034	.0041
		Peripheral - HEM	2 x D	.15 x D	5	500	.0014	.0020	.0027	.0034	.0041
		Finish	1.5 x D	.015 x D	5	475	.0015	.0022	.0030	.0037	.0045
	Cast Iron Ductile	Slotting	.5 x D	1 x D	5	300	.0010	.0014	.0019	.0024	.0029
		Peripheral - Rough	1.25 x D	.3 x D	5	375	.0012	.0018	.0024	.0030	.0036
		Peripheral - HEM	2 x D	.15 x D	5	475	.0012	.0018	.0024	.0030	.0036
		Finish	1.5 x D	.015 x D	5	450	.0013	.0020	.0027	.0033	.0040
	Cast Iron Malleable	Slotting	.5 x D	1 x D	5	250	.0010	.0014	.0019	.0024	.0029
		Peripheral - Rough	1.25 x D	.3 x D	5	325	.0012	.0018	.0024	.0030	.0036
		Peripheral - HEM	2 x D	.15 x D	5	425	.0012	.0018	.0024	.0030	.0036
		Finish	1.5 x D	.015 x D	5	400	.0013	.0020	.0027	.0033	.0040
P	Low Carbon Steel 1018, 12L14, 8620	Slotting	.5 x D	1 x D	5	350	.0012	.0017	.0023	.0029	.0035
		Peripheral - Rough	1.25 x D	.3 x D	5	425	.0015	.0022	.0029	.0036	.0044
		Peripheral - HEM	2 x D	.15 x D	5	525	.0015	.0022	.0029	.0036	.0044
		Finish	1.5 x D	.015 x D	5	500	.0016	.0024	.0032	.0040	.0048
	Medium Carbon Steels 4140, 4340	Slotting	.5 x D	1 x D	5	300	.0011	.0016	.0022	.0027	.0032
		Peripheral - Rough	1.25 x D	.3 x D	5	375	.0014	.0020	.0027	.0034	.0041
		Peripheral - HEM	2 x D	.15 x D	5	475	.0014	.0020	.0027	.0034	.0041
		Finish	1.5 x D	.015 x D	5	450	.0015	.0022	.0030	.0037	.0045
	Martensitic Stainless Steel 416, 410, 440C	Slotting	.5 x D	1 x D	5	300	.0010	.0016	.0021	.0026	.0031
		Peripheral - Rough	1.25 x D	.3 x D	5	375	.0013	.0020	.0026	.0033	.0039
		Peripheral - HEM	2 x D	.15 x D	5	475	.0013	.0020	.0026	.0033	.0039
		Finish	1.5 x D	.015 x D	5	450	.0013	.0020	.0027	.0033	.0040
H	Tool & Die Steels < 48 Rc A2, D2, H13, P20	Slotting	.5 x D	1 x D	5	300	.0010	.0016	.0021	.0026	.0031
		Peripheral - Rough	1.25 x D	.3 x D	5	375	.0013	.0020	.0026	.0033	.0039
		Peripheral - HEM	2 x D	.15 x D	5	475	.0013	.0020	.0026	.0033	.0039
		Finish	1.5 x D	.015 x D	5	450	.0013	.0020	.0027	.0033	.0040
M	Austenitic Stainless Steels 303, 304, 316	Slotting	.5 x D	1 x D	5	275	.0012	.0018	.0024	.0029	.0035
		Peripheral - Rough	1.25 x D	.3 x D	5	325	.0015	.0022	.0029	.0037	.0044
		Peripheral - HEM	2 x D	.1 x D	5	425	.0015	.0022	.0029	.0037	.0044
		Finish	1.5 x D	.015 x D	5	400	.0015	.0022	.0030	.0037	.0045
	Precipitation Hardening Stainless Steels 17-4 PH, 15-5 PH, 13-8 PH	Slotting	.5 x D	1 x D	5	250	.0008	.0012	.0017	.0021	.0025
		Peripheral - Rough	1.25 x D	.3 x D	5	300	.0010	.0016	.0021	.0026	.0031
		Peripheral - HEM	1.5 x D	.1 x D	5	400	.0010	.0016	.0021	.0026	.0031
		Finish	1.5 x D	.015 x D	5	375	.0011	.0016	.0021	.0026	.0032
S	Titanium Alloys	Slotting	.5 x D	1 x D	5	250	.0009	.0013	.0017	.0022	.0026
		Peripheral - Rough	1.25 x D	.3 x D	5	300	.0011	.0016	.0022	.0027	.0033
		Peripheral - HEM	1.5 x D	.1 x D	5	400	.0011	.0016	.0022	.0027	.0033
		Finish	1.5 x D	.015 x D	5	375	.0011	.0017	.0022	.0028	.0033
	High Temperature Alloys Inconel, Haynes, Stellite, Hastalloy	Slotting	.25 x D	1 x D	5	60	.0009	.0014	.0018	.0023	.0028
		Peripheral - Rough	1.25 x D	.25 x D	5	90	.0012	.0017	.0023	.0029	.0035
		Peripheral - HEM	1.5 x D	.1 x D	5	225	.0012	.0017	.0023	.0029	.0035
		Finish	1.5 x D	.01 x D	5	125	.0014	.0020	.0027	.0034	.0041

D = Tool diameter

Adjustments – Apply these adjustments when programming the following applications.

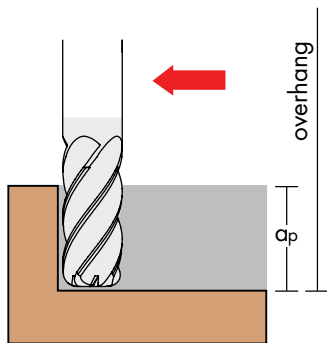

1. Long reach mills with large overhang

- Reduce speed rate and chip load by 20% each when total reach to tool diameter ratio is 5:1 or greater

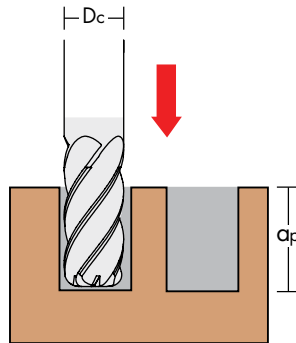

2. Plunge entry into work piece

- Reduce chip load by 80% of recommended slotting rate
- Peck mill if axial DOC (a_p) exceeds 50% of D_c

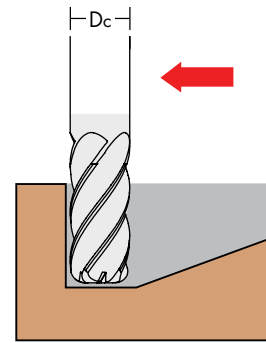

3. Ramp entry into work piece

- Ramp at 1.5°–2.5° angle
- Reduce chip load by 20% of recommended slotting rate

M905 Application Guide (metric) • Speed & Feed

ISO Classification	Work Material	Type of Cut	Axial DOC	Radial DOC	Number of Flutes	Speed (M/min)	Feed (MM per Tooth)					
							6,0	10,0	12,0	16,0	20,0	20,0
S	Titanium Alloys	Slotting	.5 x D	1 x D	5	76	0.0222	0.0368	0.0443	0.0590	0.0736	0.0784
		Peripheral - Rough	1.25 x D	.3 x D	5	91	0.0277	0.0460	0.0554	0.0737	0.0920	0.0980
		Finish	1.5 x D	.01 x D	5	114	0.0345	0.0572	0.0689	0.0917	0.1144	0.1946
	High Temperature Alloys Inconel, Haynes, Stellite, Hastalloy	Slotting	.25 x D	1 x D	5	18	0.0235	0.0389	0.0469	0.0624	0.0779	0.0713
		Peripheral - Rough	1.25 x D	.25 x D	5	27	0.0293	0.0487	0.0587	0.0780	0.0974	0.0891
		Finish	1.5 x D	.01 x D	5	38	0.0345	0.0572	0.0689	0.0917	0.1144	0.1460
M	Austenitic Stainless Steels 303, 304, 316	Slotting	.5 x D	1 x D	5	84	0.0299	0.0497	0.0599	0.0796	0.0994	0.0901
		Peripheral - Rough	1.25 x D	.3 x D	5	99	0.0374	0.0621	0.0748	0.0995	0.1242	0.1127
		Finish	1.5 x D	.01 x D	5	122	0.0465	0.0772	0.0930	0.1238	0.1545	0.1626
	Precipitation Hardening Stainless Steels 17-4 PH, 15-5 PH, 13-8 PH	Slotting	.5 x D	1 x D	5	76	0.0211	0.0350	0.0421	0.0560	0.0699	0.0784
		Peripheral - Rough	1.25 x D	.3 x D	5	91	0.0263	0.0437	0.0527	0.0700	0.0874	0.0980
		Finish	1.5 x D	.01 x D	5	114	0.0327	0.0543	0.0655	0.0871	0.1087	0.1946
P	Low Carbon Steel 1018, 12L14, 8620	Slotting	.5 x D	1 x D	5	107	0.0295	0.0489	0.0589	0.0784	0.0978	0.1151
		Peripheral - Rough	1.25 x D	.3 x D	5	130	0.0368	0.0611	0.0737	0.0980	0.1223	0.1111
		Finish	1.5 x D	.01 x D	5	152	0.0500	0.0830	0.0999	0.1329	0.1659	0.1388
	Medium Carbon Steels 4140, 4340	Slotting	.5 x D	1 x D	5	91	0.0274	0.0455	0.0549	0.0730	0.0911	0.1727
		Peripheral - Rough	1.25 x D	.3 x D	5	114	0.0343	0.0569	0.0686	0.0912	0.1138	0.1000
		Finish	1.5 x D	.01 x D	5	137	0.0465	0.0772	0.0930	0.1238	0.1545	0.1250
	Tool & Die Steels < 48 Rc A2, D2, H13, P20	Slotting	.5 x D	1 x D	5	91	0.0266	0.0442	0.0532	0.0708	0.0883	0.1554
		Peripheral - Rough	1.25 x D	.3 x D	5	114	0.0333	0.0552	0.0665	0.0885	0.1104	0.0926
		Finish	1.5 x D	.01 x D	5	137	0.0414	0.0686	0.0827	0.1100	0.1373	0.1157
	Martensitic Stainless Steel 416, 410, 440C	Slotting	.5 x D	1 x D	5	91	0.0266	0.0442	0.0532	0.0708	0.0883	0.1439
		Peripheral - Rough	1.25 x D	.3 x D	5	114	0.0333	0.0552	0.0665	0.0885	0.1104	0.0852
		Finish	1.5 x D	.01 x D	5	137	0.0414	0.0686	0.0827	0.1100	0.1373	0.1064
K	Cast Iron Gray	Slotting	.5 x D	1 x D	5	107	0.0274	0.0455	0.0549	0.0730	0.0911	0.1366
		Peripheral - Rough	1.25 x D	.3 x D	5	137	0.0343	0.0569	0.0686	0.0912	0.1138	0.1324
		Finish	1.5 x D	.01 x D	5	168	0.0465	0.0772	0.0930	0.1238	0.1545	0.0784
	Cast Iron Ductile	Slotting	.5 x D	1 x D	5	99	0.0244	0.0405	0.0488	0.0649	0.0810	0.1414
		Peripheral - Rough	1.25 x D	.3 x D	5	130	0.0305	0.0506	0.0610	0.0811	0.1012	0.1151
		Finish	1.5 x D	.01 x D	5	160	0.0414	0.0686	0.0827	0.1100	0.1373	0.0784
	Cast Iron Malleable	Slotting	.5 x D	1 x D	5	91	0.0244	0.0405	0.0488	0.0649	0.0810	0.1414
		Peripheral - Rough	1.25 x D	.3 x D	5	114	0.0305	0.0506	0.0610	0.0811	0.1012	0.1151
		Finish	1.5 x D	.01 x D	5	137	0.0414	0.0686	0.0827	0.1100	0.1373	0.1000

D = Tool diameter

Adjustments – Apply these adjustments when programming the following applications.

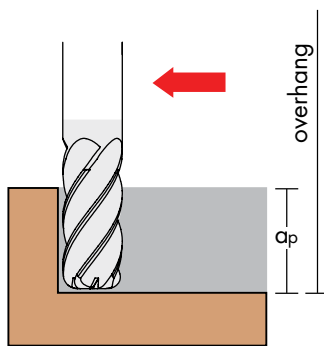

1. Long reach mills with large overhang

- Reduce speed rate and chip load by 20% each when total reach to tool diameter ratio is 5:1 or greater

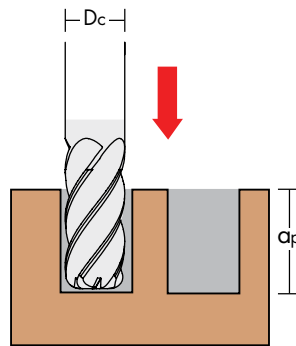

2. Plunge entry into work piece

- Reduce chip load by 80% of recommended slotting rate
- Peck mill if axial DOC (a_p) exceeds 50% of D_c

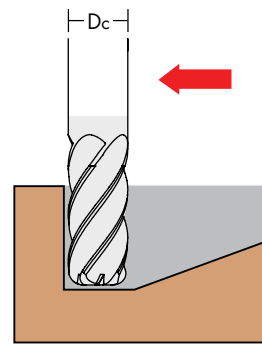

3. Ramp entry into work piece

- Ramp at 1.5°–2.5° angle
- Reduce chip load by 20% of recommended slotting rate

imcousa.com

Point. Click. Game changed.

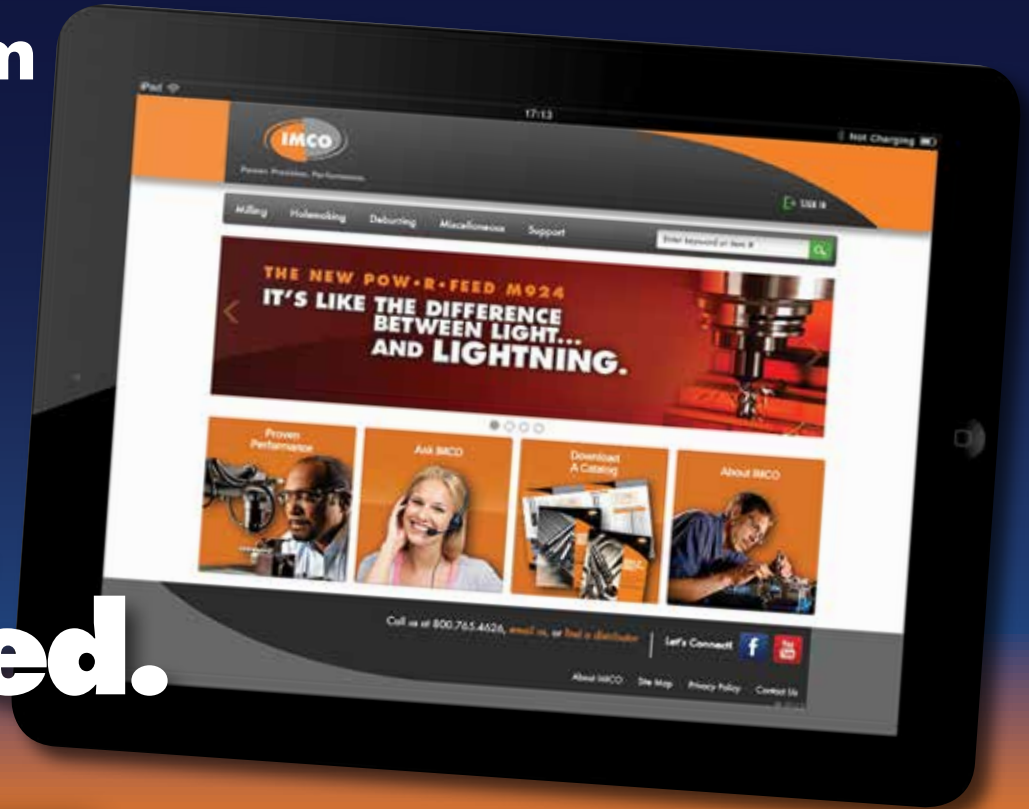

User-focused navigation – Start with machining type (milling, holesmaking, deburring, etc.), then you choose how you want look further – by tool family, by application or by end type, whatever works best for you.

Complete tool info – Dimensions and drawings, flutes, coatings, end cuts, sizes ... everything you need to know. Downloadable catalogs, too.

Real-time data for distributors – Password-protected access 24/7 for secure online ordering, real-time inventory checks, order tracking and more. With **24/7 access** to real-time information, you can respond to customer needs on the spot, anytime. When priorities shift from minute to minute, **speed and flexibility** are game changers.

"Our information technology should be as advanced, intuitive and productivity-driven as our cutting tool technology. Now, it is."

– IMCO President Perry Osburn



IMCO's new "smart" coding system saves you time locating part numbers. Just use the specifics of the tool you need, "plug" them into the coding system, and you're there!

How EZ-ID works.

Each EZ-ID part number actually describes the tool itself. It starts with general information (type of tool and tool "family") and gets more specific as you go.

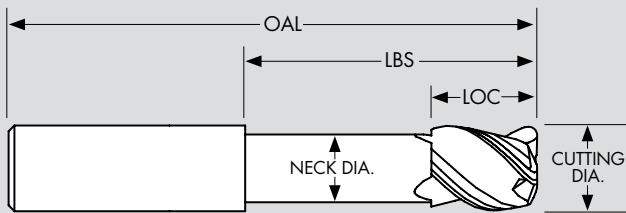

Building the EZ-ID code, step by step.

Insert the numbers in the segments as indicated here. If a certain segment doesn't apply (neck dimension, nonstandard length or special shank), just skip it. Separate the segments with hyphens.

- 1** Enter the **model number**.
For example, the model number for the new POW•R•FEED® M9 with 4 variable flutes would be M924.
- 2** Enter the **tool diameter** ((always to three decimal places). Include the leading zero for diameters less than 1 in. or 10mm
- 3** Enter the **length of cut (LOC)**. Include the leading zero for a LOC less than 1 in. or 100 mm.
- 4** Enter the **length below shank (LBS) or reach**. Include the leading zero for a LBS less than 1 in. or 100 mm. Indicate that this is a neck dimension by placing an N before the number. (If the tool has no neck, you can skip this segment altogether.)
- 5** Enter the **end/corner** type or size. Include the leading zero for corner radii less than 1 in. or 1mm. For any other end/corner type, just indicate the type: SQ = square end, BN = ball nose, CC = corner chamfer.
- 6** If the **overall length** you need is not the standard length for the combination of tool diameter, LOC and LBS, then enter the overall length (**OAL**) here. Indicate that this is an overall length by placing an L before the number. If you do not specify an overall length, we will assume it is standard length..
- 7** Enter the code for the **type of shank** you need (W = Weldon flat, WN = whistle notch, P = plain). If you do not specify a shank style, we will assume it is a plain shank.

	1	2	3	4	5	6	7
	MODEL	TOOL DIAMETER	LENGTH OF CUT (LOC)	LENGTH BELOW SHANK (LBS)	END	OVERALL LENGTH	SHANK
INCH	M924	0750	1500	N3375	060	L6	W
METRIC	M924	120	024	N055	100	L100	W

Segments highlighted in white may be omitted.

**Get POW•R•FEED® end mills for
your slice of the action.**

See a video of POW•R•FEED M9 Series end mills
in action at:

www.youtube.com/watch?v=jPc_6BlfddY

Test M9 Series tools for yourself. To order, or for
more information:

In USA call **1-800-765-4626**

International **419-661-6313**

Fax **419-661-6314**



Visit **www.imcousa.com**
by scanning this code with a
QR code reader.



Power. Precision. Performance.

ISO 9001:2000 Registered

(Made in U.S.A.)

©2013 IMCO Carbide Tool Inc