

AHB

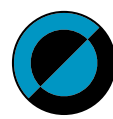

Member IMC Group
Ingersoll
Cutting Tools

TOOLING & MACHINERY

COMPLETE METALWORKING SOLUTIONS

(800) 991-4225
ISO Certified

www.ahbinc.com
customerservice@ahbinc.com

INGGEAR
PRODUCTION

INGERSOLL VERZÄHNUNGSWERKZEUGE
INGERSOLL GEAR PRODUCTION



2021

INGERSOLL WERKZEUGE GMBH – DAS UNTERNEHMEN SPEZIALIST BEI DER HERSTELLUNG VON VERZÄHNUNGSWERKZEUGEN



Im Jahr 1962 begann Ingersoll Werkzeuge GmbH mit 23 Mitarbeitern die Fertigung von Fräs- und Bohrwerkzeugen als Tochter der Ingersoll International Inc. in Rockford/USA. Die ersten Verzahnungswerkzeuge wurden als nachschleifbare Werkzeuge mit austauschbaren HSS- bzw. Hartmetall-Messern gefertigt. Das Schleifen, bzw. Nachschleifen der Werkzeuge, gemäß dem zu erzeugenden Profil, erfolgte auf Ingersoll-Messerkopf-Schleifmaschinen.

Um den Forderungen an die Zerspanleistung beim Verzählen gerecht zu werden, entwickelten Ingersoll-Ingenieure im Jahr 1977 das erste Verzahnungswerkzeug Modul 16 in Ø370 mm als Vorfräser mit HM-Wendeschnidplatten.

Einen weiteren Meilenstein stellte die Entwicklung von Wälzfräsern mit HM-Wendeschnidplatten dar. Nur zwei Jahre später, im Jahr 1979, konzipierte Ingersoll den ersten Schälwälzfräser Modul 25 in Ø400 mm mit 4 Segmenten. Mit Stolz kann man sagen, dass Ingersoll über eine langjährige Erfahrung im Bereich der Verzahnung verfügt. In diesem Zeitraum fertigte Ingersoll zahlreiche Standard-, bzw. speziell auf die Kundenwünsche angepasste Zerspanungswerkzeuge von Modul 1 bis hin zu größeren Modulen, wie z.B. den Zahnformvorfräser Modul 60 in Ø520 mm, das Zahnformschlichtwerkzeug Modul 100 in Ø460 mm und den größten Wälzfräser Modul 42 in Ø500 mm.

Ingersoll verfügt über das nötige Engineering, um den hohen technischen und zeitlichen Anforderungen zu entsprechen.





Ingersoll Cutting Tools started the production of milling and boring tools in 1962 with just 23 employees, as a subsidiary of Ingersoll International Inc. in Rockford, USA. The first gear milling tools were made as grind-type tools with exchangeable HSS as well as solid carbide blades. The grinding and regrinding of the tools, according to the specific profile, was carried out on Ingersoll profile grinding machines.

In order to meet the demands of metal cutting in gear milling, the engineers at Ingersoll designed in 1977 the first roughing gasher, module 16, diameter 370 mm, with indexable carbide inserts. A further milestone came with the development of hobs with indexable carbide inserts. Only two years later, in 1979, Ingersoll designed the first skiving hob, module 25, 400 mm in diameter, with four segments.

It is with pride, that Ingersoll looks back on many years of experience in the field of gearing. During the last years, Ingersoll has designed numerous cutting tools; both in standard design, as well as special design, in accordance with the individual needs of the customer, from module 1 to larger modules as for example the roughing gasher, module 60 with a diameter of 520 mm, the finishing gasher, module 100, 460 mm in diameter, as well as the largest hob, module 42, with a diameter of 500 mm.

Ingersoll has the essential engineering know-how to comply with the high technical and temporal requirements.

GEARGASH

S-MAX Zahnform-Vorfräser BP IV (DIN 3972)
S-MAX Roughing gasher BP IV (DIN 3972).....06-07

Kundenspezifische Sonderausführung der Vorfräser
Custom-made special designed roughing gasher.....08

Neue Generation Zahnformfräser mit Kühlkanälen
New generation of gear gasher with coolant channel.....09

Zahnform-Vorfräser BP IV (DIN 3972)
Roughing gasher BP IV (DIN 3972).....10-11

Schnittwertempfehlung Zahnform-Vorfräser BP IV (Schnitt 1/2)
Cutting data recommendation roughing gasher BP IV (Cut 1/2).....12-13

INGERSOLL Zahnformschlichtfräser (innen & außen)
INGERSOLL finishing gasher (Internal & external).....14-15

Zahnformschlichtfräser mit 2-schneidiger Profil-WSP (innen)
Gear finishing gasher with 2-edged Profile ground insert (internal).....16-17

Zahnformschlichtfräser mit 2-schneidiger Profil-WSP (ausen)
Gear finishing gasher with 2-edged Profile ground insert (external).....18-19

Zahnformschlichtfräser Mit 4-schneidiger Profil-WSP (innen)
Gear finishing gasher with 4-edged profile Ground insert (internal).....20-21

ZahnformSchlichtfräser Mit 4-schneidiger Profil-WSP (ausen)
Gear finishing gasher with 4-edged profile Ground insert (External).....22-23

Schnittwertempfehlung Zahnformschlichtfräser (innen/ausen)
Cutting data recommendation finishing gasher (internal/external).....24

Gewindezirkularfräser 17Y1_
Thread mill 17Y1_.....25

GEARHOB

Ingersoll Wälzfräser
Ingersoll Hobs.....27-28

Bezugsprofile der Verzahnungswerkzeuge
Basic rack profiles of gear generating tools.....29

Wälzfräser BP II (DIN 3972)
Hobs BP II (DIN 3972).....30-31

Schnittwertempfehlung Wälzfräser BP II (DIN 3972)
Cutting data recommendation Hobs BP II (DIN 3972).....32

Wälzfräser BP II (DIN 3972)
Hobs BP II (DIN 3972).....33

Schruppwälzfräser mit Protuberanz
Roughing hobs with protuberance.....34-35

Schnittwertempfehlung Schruppwälzfräser mit protuberanz
Cutting data recommendation roughing hobs with protuberance.....36

Allgemeine Beschreibung
GeneralDescription.....37

Schlichtwälzfräser BP II (DIN 3972)
Finish hobs BP II (DIN 3972).....38-39

Schruppwälzfräser mit Protuberanz
Roughing hobs with protuberance.....40-41

Schlichtwälzfräser DIN 5480
Finish hobs DIN 5480.....42-43

Gegenüberstellung
Comparison.....44

Toleranzen / DIN 3968
Tolerances / DIN 3968.....45-47

GEARSHAPE

Wendeplattenstoßrad 74x8D
Indexable insert gear shaper 74x8D.....50-51

Schneidräder BP II (DIN 3972)
Shaper BP II (DIN 3972).....52-53

Schneidräder (DIN 5480)
Shaper (DIN 5480).....54-55

GEARSKIVE

Wälzschälräder BP II (DIN 3972)
Skiving cutter BP II (DIN 3972).....60-61

Schneidräder (DIN 5480)
Shaper (DIN 5480).....62-63

SOLID CARBIDE

Vollhartmetall Lösungen für kleine Module
Solid carbide solutions for small modules.....66-67

GEARGASH

ChipSurfer Zahnform-Nutfräser BP II (DIN 3972)
ChipSurfer gear finishing gasher BP II (DIN 3972).....68

Vollhartmetall Lösungen für Schneid und Wälzfräsen
Solid carbide solutions for shaper & skiving cutter.....69

GEARSHAPE

ChipSurfer-Schneidräder BP II (DIN 3972)
ChipSurfer-Shaper BP II (DIN 3972).....70

ChipSurfer-Schneidräder (DIN 5480)
ChipSurfer-Shaper (DIN 5480).....71

GEARSKIVE

ChipSurfer-Wälzschälräder BP II (DIN 3972)
ChipSurfer skiving cutter BP II (DIN 3972).....72

ChipSurfer-Wälzschälräder (DIN 5480)
ChipSurfer skiving cutter (DIN 5480).....73

Werkzeugspezifikation für technische Angebotserstellung
Tool Specification technical quotation for74-77

Gegenüberstellung: Teilung - Modul - DP - CP
Comparison: Pitch - Module - Diametral pitch - Circular pitch.....78

Inspektion & Werkzeug-Instandsetzungsservice
Inspection & Tool Maintenance Service.....79



Allgemeine Beschreibung / General Description

Die neu entwickelte Werkzeugserie für die Vorbearbeitung von Außen- und Innenverzahnungen ist eine Optimierung aus negativen und doppelt positiven, tangentialen Schneidgeometrien. Im Zahngrund sorgt die negative Wendeschneidplatte für die nötige Stabilität, um hohe Vorschübe, und damit hohe Abtragsleistungen zu realisieren. Die negative Wendeschneidplatte ist mit einer Schrägbohrung versehen. Durch die schräge Einbaulage der Wendeschneidplattenschraube erreichen wir eine größere Gewindetiefe, die den Wendeplattensitz und damit das Werkzeug stabilisiert. Die doppelt positive S-MAX Wendeschneidplatte sorgt an der Zahnflanke für einen weichen Schneidvorgang, was die Abdrängkräfte enorm reduziert.

Die auf den Zerspanungsprozess genau abgestimmte Schneidenaufteilung sorgt für einen ruhigen Lauf des Werkzeuges. Die Form der Werkzeuge ist gemäß Bezugsprofil IV (DIN 3972) ausgelegt. Alternative Bezugsprofile können selbstverständlich kundenspezifisch hergestellt werden. Bei der Vorbearbeitung von Ritzeln mit niedriger Zähnezahl kann es unter Umständen wirtschaftlicher sein, ein der Evolventenform angepasstes Werkzeug mit Protuberanzschneiden einzusetzen. Solche Werkzeuge können in Sonderausführung geliefert werden.

The newly developed tool series for the pre-machining of outer and inner gear production, is the result of the optimization of negative and double-positive tangential cutting edge geometry. At the root of the tooth, the negative insert provides the stability necessary to implement high feed rates thus realizing a high chip removal rate. The negative insert has an inclined bore. With the inclined position of the insert screw a higher depth of thread is achieved, which stabilizes the insert pocket and thus the whole tool. The double-positive S-MAX insert allows for a smooth cutting process at the flank of the tooth, which reduces the axial force enormously.

The exact positioning of inserts for each individual cutting process provides a vibration-free performance of the cutter. It is certainly possible to produce alternative profiles according to customers' specifications. When pre-machining pinions with a low amount of teeth, it may be more economical to use a tool which complies to the involute shape with protuberance inserts. Tools such as these can be supplied in special design.

Modul Module	S_w	h_{kw}	p	K_w	K_{w1}	R_w	h_w
6	9,43	8,59	0,37	3,17	-	1,2	14,7
8	12,57	11,20	0,41	4,41	-	1,8	19,6
10	15,71	13,79	0,44	5,67	-	1,8	24,5
12	18,82	16,37	0,47	6,93	-	2,8	29,4
14	21,99	18,95	0,50	8,20	-	2,8	34,3
16	25,13	21,51	0,52	9,47	-	2,8	39,2
18	28,27	24,07	0,54	10,75	-	4,0	44,1
20	31,42	26,63	0,56	12,03	-	4,0	49,0
22	34,56	29,18	0,58	13,32	12,3	4,0	53,9
24	37,70	31,73	0,59	14,60	-	4,0	58,8
26	40,84	34,28	0,61	15,89	-	4,0	63,7
28	43,98	36,82	0,62	17,18	-	4,0	68,6
30	47,12	39,36	0,64	18,47	15,9	4,0	73,5
32	50,27	41,91	0,65	19,76	17,2	4,0	78,4
34	53,41	44,44	0,67	21,05	-	5,0	83,3
36	56,55	46,98	0,68	22,35	19,3	5,0	88,2



Vorfräsen eines Hohlrades Modul 16
 Roughing of annulus module 16

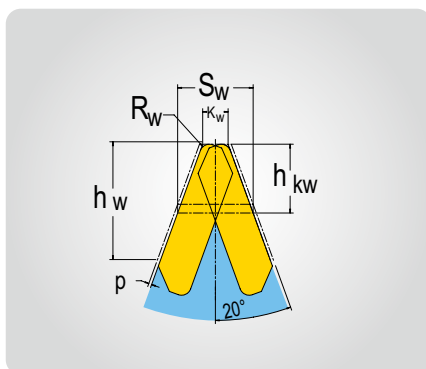

Modul 6
 Module 6

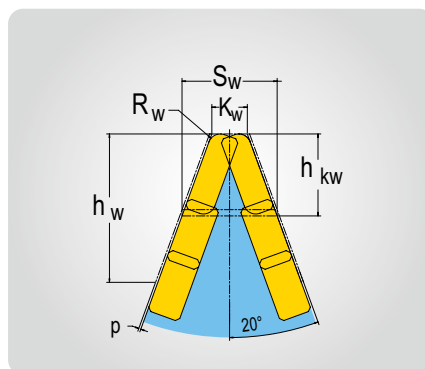

Modul 8 - Modul 26
 Module 8 - Module 26

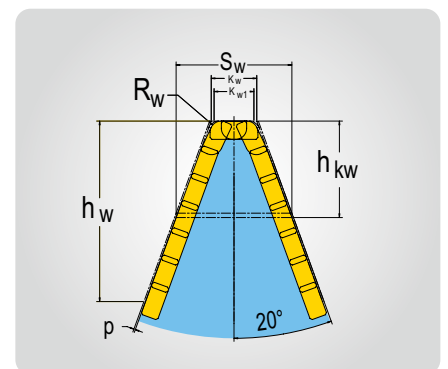

Modul 28 - Modul 36
 Module 28 - Module 36

Anwendungsbeispiele / Application Examples

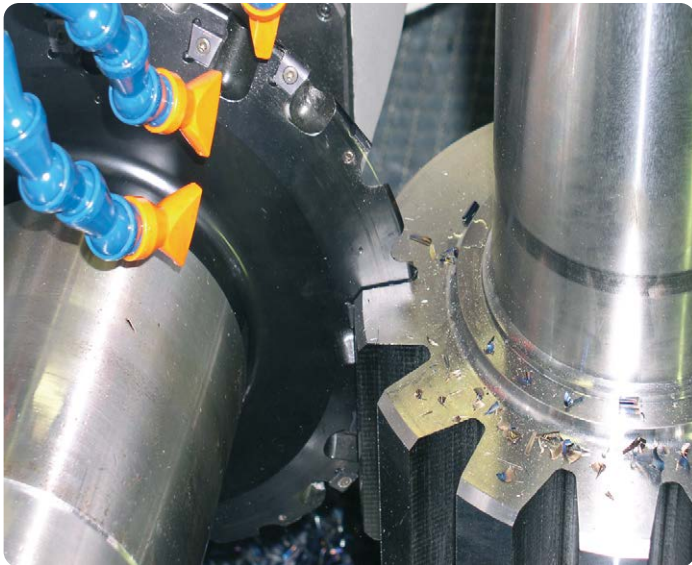

Zahnform-Vorfräser

Schaftritzel Modul 16; Werkstoff: 18CrNiMo6

$D = 360 \text{ mm}$ $n = 95 \text{ min}^{-1}$
 $fz = 0,4 \text{ mm}$ $vf = 304 \text{ mm/min}$
 $ae = 36,5 \text{ mm}$

Roughing Gasher

Pinion gear module 16; material: 18CrNiMo6

$D = 360 \text{ mm}$ $n = 95 \text{ rpm}$
 $fz = 0,4 \text{ mm}$ $vf = 304 \text{ mm/min}$
 $ae = 36,5 \text{ mm}$

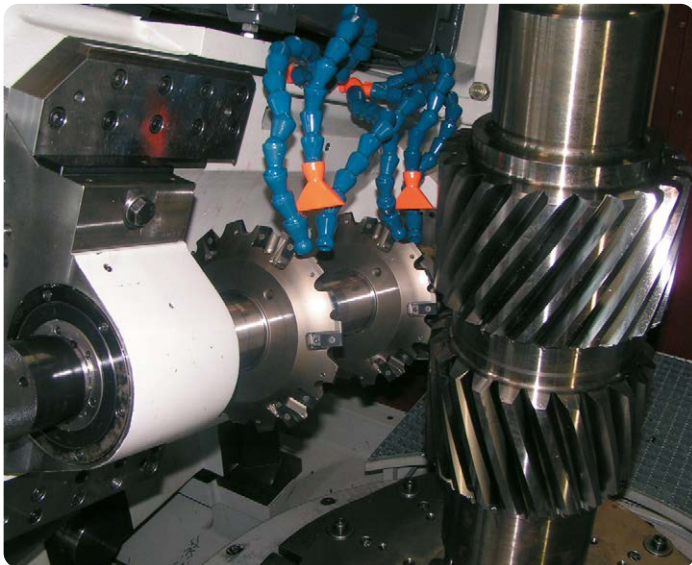

Zahnform-Vorfräser

mit formgeschliffenen Wendeschneidplatten zur Erzielung eines gleichmäßigen Aufmaßes zum Schleifen. Ausführung mit Protuberanz. Schaftritzel Modul 10; Werkstoff: 18CrNiMo6

$D = 250 \text{ mm}$ $n = 180 \text{ min}^{-1}$
 $fz = 0,4 \text{ mm}$ $vf = 430 \text{ mm/min}$
 $ae = 22,5 \text{ mm}$

Roughing Gasher

with profile ground inserts to obtain an equal stock. Design including protuberance. Pinion gear module 10; material: 18CrNiMo6

$D = 250 \text{ mm}$ $n = 180 \text{ rpm}$
 $fz = 0,4 \text{ mm}$ $vf = 430 \text{ mm/min}$
 $ae = 22,5 \text{ mm}$

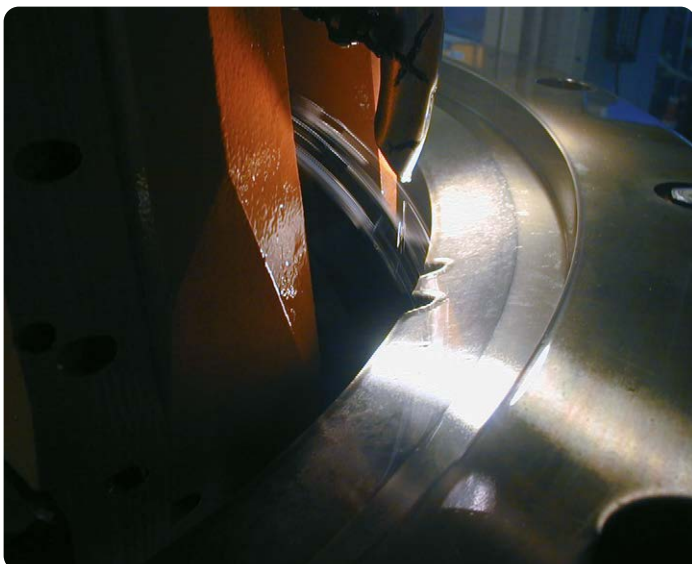

Duplex-Vorfräser

mit formgeschliffenen Wendeschneidplatten zur Erzielung eines gleichmäßigen Aufmaßes zum Schleifen. Ausführung mit Protuberanz. Hohlrad Modul 16; Werkstoff: 42CrMo4

$D = 420 \text{ mm}$ $n = 100 \text{ min}^{-1}$
 $fz = 0,38 \text{ mm}$ $vf = 380 \text{ mm/min}$
 $ae = 36,7 \text{ mm}$

Duplex-Roughing Gasher

with profile ground inserts to obtain an equal stock. Design including protuberance. Annulus module 16; material: 42CrMo4

$D = 420 \text{ mm}$ $n = 100 \text{ rpm}$
 $fz = 0,38 \text{ mm}$ $vf = 380 \text{ mm/min}$
 $ae = 36,7 \text{ mm}$

Sonderausführung / Custom-made

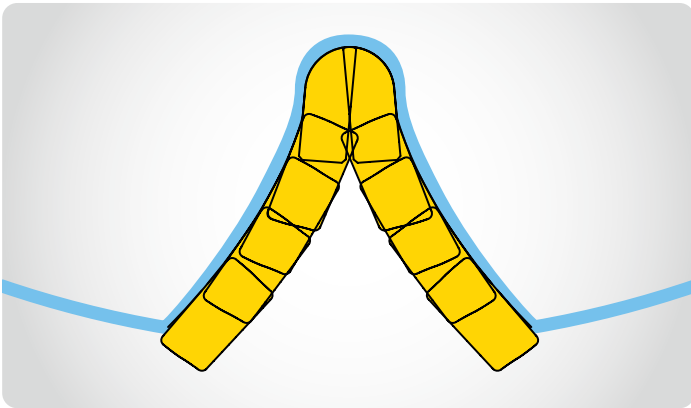

Vorfräser für Ritzel

mit ungleichmäßigem Aufmaß an der Flanke und fertig gefräster Protuberanz.

- Protuberanz-Wendeschneidplatten 4- bzw. 2-fach einsetzbar.
- Flanken-Wendeschneidplatte 4-fach einsetzbar.

Roughing gasher for pinion gear

with unequal stock at the flank and finish milled protuberance.

- Protuberance insert with four respectively two cutting edges.
- Flank insert with four cutting edges.



Vorfräser für Ritzel

mit gleichmäßigem Aufmaß an der Flanke und fertig gefräster Protuberanz.

- Protuberanz-Wendeschneidplatte 4-fach einsetzbar.
- Evolventen-Wendeschneidplatte 2-fach einsetzbar.

Roughing gasher for pinion gear

with equal stock at the flank and finish milled protuberance.

- Protuberance insert with four cutting edges.
- Involute insert with two cutting edges.

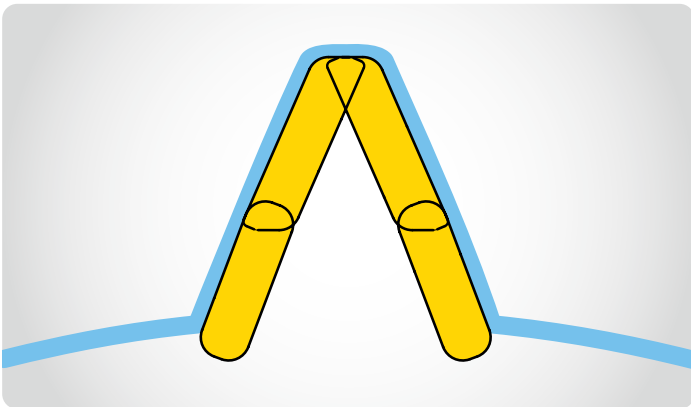

Vorfräser für Hohlräder

mit ungleichmäßigem Aufmaß.

- Wendeschneidplatte 4-fach einsetzbar

Roughing gasher for annuluses

with an unequal stock.

- Insert with four cutting edges.

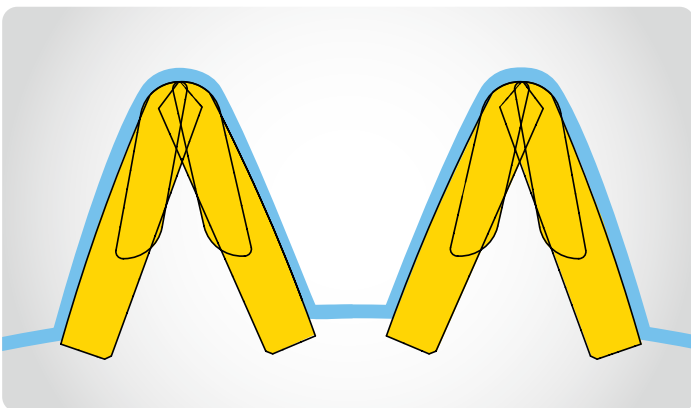

Vorfräser für Hohlräder

mit gleichmäßigem Aufmaß an der Flanke und fertig gefräster Protuberanz.

- Protuberanz-Wendeschneidplatte 4-fach einsetzbar.
- Evolventen-Wendeschneidplatte 2-fach einsetzbar.

Roughing gasher for annuluses

with an equal stock at the flank and finish milled protuberance.

- Protuberance insert with four cutting edges.
- Involute insert with two cutting edges.



Zahnformvorfräser mit Kühlkanälen /
Roughing gasher with coolant channel

Ingersoll Werkzeuge GmbH fertigt schon seit längerem Fräs- und Bohrwerkzeuge mit innerer Kühlmittelzufuhr. Diese positiven Erfahrungen waren Anlass genug, auch für den Bereich der Verzahnungswerkzeuge eine Kühlmittelzufuhr (Luft oder Emulsion) zu entwickeln. Die Kühlkanäle sind im Fräser so angeordnet, dass das Medium die Werkzeugschneide direkt kühlt.

Neben dem positiven Effekt des Kühlens werden die Späne aus dem Arbeitsbereich weggeblasen bzw. weggespült, was einen entscheidenden Einfluss auf den Standweg der Wendeschneidplatten hat. Ein weiterer Vorteil ist die geringere Erwärmung Ihres Werkstückes bei der Bearbeitung, was sich positiv auf die Qualität Ihres Produktes auswirkt.

Innovative Technologie dank Ingersoll!



Zahnformschlichtfräser mit Kühlkanälen
Finishing gasher with coolant channels

For a long period of time Ingersoll Werkzeuge GmbH has produced milling and boring tools with internal coolant supply. These positive experiences were reason enough to develop a coolant supply (air or emulsion) for the various gear gasher types as well. The coolant channels are positioned in the tool in such a way that the respective medium cools the insert directly.

In addition to the positive cooling effect the chips are either blown or flushed away from the operation area which has an enormous influence on the tool life of the inserts. Another advantage is the lower degree of warming of the workpiece during the machining operation which has a positive effect on the quality of your product.

Innovative technology thanks to Ingersoll!

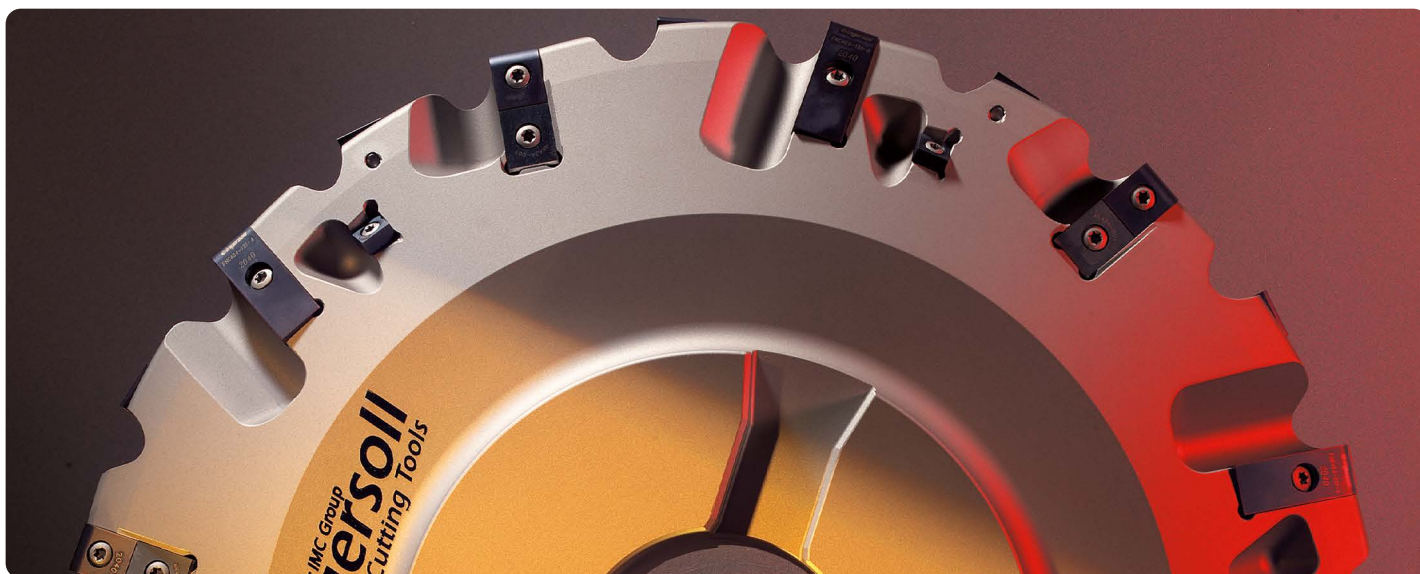







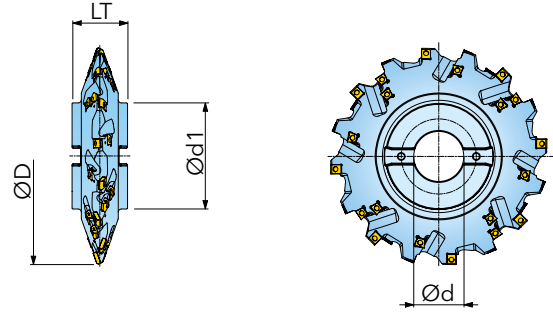



Fräser mit Quernut
 Cutter with radial keyway

DIN 138

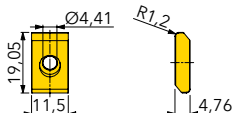
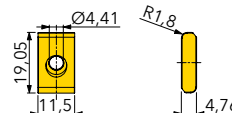
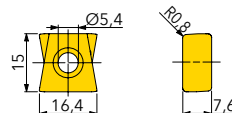
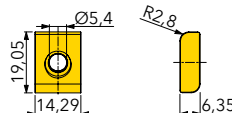

Modul Module	Artikel-Nr. Designation	D	d	LT	Z	Zeff.	d1	Passende WSP Fitting insert
6	37W8F210006GE-00	210	50	50	16	8	120	16x A
	37W8F270006GF-00	270	60	50	20	10	140	20x A
	37W8F350006GA-00	350	80	70	24	12	170	24x A
8	3SW8F210008GE-00	210	50	50	24	8/4	120	16x B 8x C, H
	3SW8F270008GF-00	270	60	50	30	10/5	140	20x B 10x C, H
	3SW8F350008GA-00	350	80	70	36	12/6	170	24x B 12x C, H
10	3SW8F210010GE-00	210	50	60	24	8/4	120	16x B 8x C, H
	3SW8F270010GF-00	270	60	60	30	10/5	140	20x B 10x C, H
	3SW8F350010GA-00	350	80	70	36	12/6	170	24x B 12x C, H
12	3SW8K210012GE-00	210	50	70	24	6/3	120	12x D 12x C, H
	3SW8K270012GF-00	270	60	70	24	6/3	140	12x D 12x C, H
	3SW8K350012GA-00	350	80	90	32	8/4	170	16x D 16x C, H
14	3SW8K210014GE-00	210	50	70	24	6/3	120	12x D 12x C, H
	3SW8K270014GF-00	270	60	70	24	6/3	140	12x D 12x C, H
	3SW8K350014GA-00	350	80	90	32	8/4	170	16x D 16x C, H
16	3SW8K270016GF-00	270	60	90	30	6/3	140	12x D 18x C, H
	3SW8K350016GA-00	350	80	90	40	8/4	170	16x D 24x C, H
	3SW8K450016GC-00	450	100	90	50	10/5	190	20x D 30x C, H
18	3SW8M270018GF-00	270	60	90	30	6/3	140	12x E 18x C, H
	3SW8M350018GA-00	350	80	90	40	8/4	170	16x E 24x C, H
	3SW8M450018GC-00	450	100	90	50	10/5	190	20x E 30x C, H
20	3SW8M270020GF-00	270	60	90	36	6/3	130	12x E 24x C, H
	3SW8M350020GA-00	350	80	90	48	8/4	170	16x E 32x C, H
	3SW8M450020GC-00	450	100	90	60	10/5	190	20x E 40x C, H
22	3SW8M270022GF-00	270	60	90	36	6/3	130	12x E 24x C, H
	3SW8M350022GA-00	350	80	90	48	8/4	170	16x E 32x C, H
	3SW8M450022GC-00	450	100	90	60	10/5	190	20x E 40x C, H
24	3SW8N270024GF-00	270	60	100	36	6/3	130	12x F 24x C, H
	3SW8N350024GA-00	350	80	100	48	8/4	170	16x F 32x C, H
	3SW8N450024GC-00	450	100	100	60	10/5	190	20x F 40x C, H
26	3SW8N350026GA-00	350	80	120	56	8/4	170	16x F 40x C, H
	3SW8N450026GC-00	450	100	120	70	10/5	190	20x F 50x C, H
28	3SW8M350028GA-00	350	80	120	56	8/4	170	16x E 40x C, H
	3SW8M450028GC-00	450	100	120	70	10/5	190	20x E 50x C, H
30	3SW8M350030GA-00	350	80	120	64	8/4	160	16x E 48x C, H
	3SW8M450030GC-00	450	100	120	80	10/5	190	20x E 60x C, H
32	3SW8M400032GA-00	400	80	120	64	8/4	170	16x E 48x C, H
	3SW8M500032GC-00	500	100	120	80	10/5	190	20x E 60x C, H
34	3SW8N400034GA-00	400	80	120	64	8/4	170	16x G 48x C, H
	3SW8N500034GC-00	500	100	120	80	10/5	190	20x G 60x C, H
36	3SW8N400036GA-00	400	80	140	72	8/4	170	16x G 56x C, H
	3SW8N500036GC-00	500	100	140	90	10/5	190	20x G 70x C, H



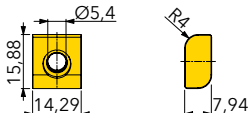
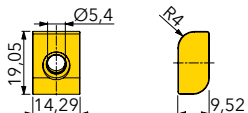
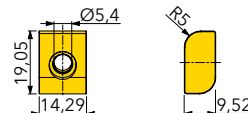
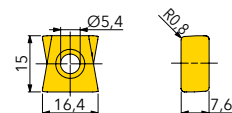

WENDESCHNEIDPLATTEN / INSERTS

A LNV333-500T05-A	B LNV333-501T05-A	C DPM424-001	D LNV434-500T05-A
 Fuß Root	 Fuß Root	 Flanke Flank	 Fuß Root
			
E LNV425-500T05-A	F LNV436-500T05-A	G LNV436-501T05-A	H DPX424-001
 Fuß Root	 Fuß Root	 Fuß Root	 Flanke Flank
			

Artikel-Nr. Designation	Ausführung Description	Qualität Grade	IN2040	IN2505	IN2530
LNV_	negative Geometrie / negative geometry				
DPM_	positive Geometrie R 0,8 / positive geometry R 0,8				
DPX_	positive Geometrie R 0,8 / positive geometry R 0,8				

● = P ● = M ● = K ● = N ● = S ○ = H

ZUBEHÖR / SPARE PARTS

<p>Senkschraube / Insert screw</p> <p>SM40-110-00</p> <p>für Platten / for inserts:</p> <p>A</p> 	<p>Senkschraube / Insert screw</p> <p>SM40-090-00</p> <p>für Platten / for inserts:</p> <p>B</p> 	<p>Senkschraube / Insert screw</p> <p>SM50-120-10</p> <p>für Platten / for inserts:</p> <p>C D H</p> 	<p>Senkschraube / Insert screw</p> <p>SM50-140-10</p> <p>für Platten / for inserts:</p> <p>C D H</p> 
<p>Senkschraube / Insert screw</p> <p>SM50-160-10</p> <p>für Platten / for inserts:</p> <p>C D E F G H</p> 			

SCHNITTWERTEMPFEHLUNG ZAHNFORM-VORFRÄSER BP IV (SCHNITT 1)
CUTTING DATA RECOMMENDATION ROUGHING GASHER BP IV (CUT 1)



Modul Module	Artikel-Nr. Designation	D [mm]	Zeфф.	ae1 [mm] Schnitt1/cut1	fz1 [mm] Schnitt1/cut1	Vc1 [m/min] Rm < 1000 N/mm ²	Vc1 [m/min] Rm > 1000 N/mm ²
6	37W8F210006GE-00	210	8	13,5	0,40-0,50	160-180	140-160
	37W8F270006GF-00	270	10	13,5	0,50-0,60	160-180	140-160
	37W8F350006GA-00	350	12	13,5	0,55-0,65	160-180	140-160
8	3SW8F210008GE-00	210	8/4	18,0	0,35-0,45	160-180	140-160
	3SW8F270008GF-00	270	10/5	18,0	0,40-0,50	160-180	140-160
	3SW8F350008GA-00	350	12/6	18,0	0,45-0,55	160-180	140-160
10	3SW8F210010GE-00	210	8/4	22,5	0,35-0,45	150-170	130-150
	3SW8F270010GF-00	270	10/5	22,5	0,40-0,50	150-170	130-150
	3SW8F350010GA-00	350	12/6	22,5	0,45-0,55	150-170	130-150
12	3SW8K210012GE-00	210	6/3	27,0	0,30-0,40	150-170	130-150
	3SW8K270012GF-00	270	6/3	27,0	0,35-0,45	150-170	130-150
	3SW8K350012GA-00	350	8/4	27,0	0,40-0,50	150-170	130-150
14	3SW8K210014GE-00	210	6/3	31,5	0,30-0,40	140-160	120-140
	3SW8K270014GF-00	270	6/3	31,5	0,35-0,45	140-160	120-140
	3SW8K350014GA-00	350	8/4	31,5	0,40-0,50	140-160	120-140
16	3SW8K270016GF-00	270	6/3	36,0	0,30-0,40	140-160	120-140
	3SW8K350016GA-00	350	8/4	36,0	0,35-0,45	140-160	120-140
	3SW8K450016GC-00	450	10/5	36,0	0,40-0,50	140-160	120-140
18	3SW8M270018GF-00	270	6/3	40,5	0,28-0,38	140-160	120-140
	3SW8M350018GA-00	350	8/4	40,5	0,32-0,40	140-160	120-140
	3SW8M450018GC-00	450	10/5	40,5	0,35-0,45	140-160	120-140
20	3SW8M270020GF-00	270	6/3	45,0	0,28-0,34	140-160	120-140
	3SW8M350020GA-00	350	8/4	45,0	0,31-0,38	140-160	120-140
	3SW8M450020GC-00	450	10/5	45,0	0,34-0,43	140-160	120-140
22	3SW8M270022GF-00	270	6/3	39,5	0,29-0,36	120-140	100-120
	3SW8M350022GA-00	350	8/4	39,5	0,32-0,40	120-140	100-120
	3SW8M450022GC-00	450	10/5	39,5	0,35-0,45	120-140	100-120
24	3SW8N270024GF-00	270	6/3	43,0	0,28-0,35	120-140	100-120
	3SW8N350024GA-00	350	8/4	43,0	0,30-0,38	120-140	100-120
	3SW8N450024GC-00	450	10/5	43,0	0,34-0,44	120-140	100-120
26	3SW8N350026GA-00	350	8/4	46,5	0,30-0,38	120-140	100-120
	3SW8N450026GC-00	450	10/5	46,5	0,33-0,43	120-140	100-120
28	3SW8M350028GA-00	350	8/4	50,5	0,29-0,37	120-140	100-120
	3SW8M450028GC-00	450	10/5	50,5	0,32-0,42	120-140	100-120
30	3SW8M350030GA-00	350	8/4	54,0	0,28-0,35	120-140	100-120
	3SW8M450030GC-00	450	10/5	54,0	0,30-0,40	120-140	100-120
32	3SW8M400032GA-00	400	8/4	57,5	0,30-0,40	120-140	100-120
	3SW8M500032GC-00	500	10/5	57,5	0,32-0,42	120-140	100-120
34	3SW8N400034GA-00	400	8/4	61,0	0,28-0,38	120-140	100-120
	3SW8N500034GC-00	500	10/5	61,0	0,30-0,40	120-140	100-120
36	3SW8N400036GA-00	400	8/4	64,5	0,28-0,38	120-140	100-120
	3SW8N500036GC-00	500	10/5	64,5	0,30-0,40	120-140	100-120

Die angegebenen Werte sind eine Empfehlung, die wir natürlich den Gegebenheiten vor Ort anpassen bzw. entsprechend optimieren.
 The indicated cutting data can only be a recommendation and must be adapted on location and, if necessary, optimized.

SCHNITTWERTEMPFEHLUNG ZAHNFORM-VORFRÄSER BP IV (SCHNITT 2)
CUTTING DATA RECOMMENDATION ROUGHING GASHER BP IV (CUT 2)



Modul Module	Artikel-Nr. Designation	D [mm]	Zeff.	ae2 [mm] Schnitt2/cut2	fz2 [mm] Schnitt2/cut2	Vc2 [m/min] Rm<1000 N/mm ²	Vec2 [m/min] Rm>1000 N/mm ²	
6	37W8F210006GE-00	210	8	-	-	-	-	Bearbeitung in einem Schnitt Machining in one cut
	37W8F270006GF-00	270	10	-	-	-	-	
	37W8F350006GA-00	350	12	-	-	-	-	
8	3SW8F210008GE-00	210	8/4	-	-	-	-	
	3SW8F270008GF-00	270	10/5	-	-	-	-	
	3SW8F350008GA-00	350	12/6	-	-	-	-	
10	3SW8F210010GE-00	210	8/4	-	-	-	-	
	3SW8F270010GF-00	270	10/5	-	-	-	-	
	3SW8F350010GA-00	350	12/6	-	-	-	-	
12	3SW8K210012GE-00	210	6/3	-	-	-	-	
	3SW8K270012GF-00	270	6/3	-	-	-	-	
	3SW8K350012GA-00	350	8/4	-	-	-	-	
14	3SW8K210014GE-00	210	6/3	-	-	-	-	
	3SW8K270014GF-00	270	6/3	-	-	-	-	
	3SW8K350014GA-00	350	8/4	-	-	-	-	
16	3SW8K270016GF-00	270	6/3	-	-	-	-	
	3SW8K350016GA-00	350	8/4	-	-	-	-	
	3SW8K450016GC-00	450	10/5	-	-	-	-	
18	3SW8M270018GF-00	270	6/3	-	-	-	-	
	3SW8M350018GA-00	350	8/4	-	-	-	-	
	3SW8M450018GC-00	450	10/5	-	-	-	-	
20	3SW8M270020GF-00	270	6/3	-	-	-	-	
	3SW8M350020GA-00	350	8/4	-	-	-	-	
	3SW8M450020GC-00	450	10/5	-	-	-	-	
22	3SW8M270022GF-00	270	6/3	10	0,55-0,67	140-160	120-140	
	3SW8M350022GA-00	350	8/4	10	0,62-0,75	140-160	120-140	
	3SW8M450022GC-00	450	10/5	10	0,70-0,85	140-160	120-140	
24	3SW8N270024GF-00	270	6/3	11	0,50-0,65	140-160	120-140	
	3SW8N350024GA-00	350	8/4	11	0,60-0,73	140-160	120-140	
	3SW8N450024GC-00	450	10/5	11	0,65-0,80	140-160	120-140	
26	3SW8N350026GA-00	350	8/4	12	0,55-0,67	140-160	120-140	
	3SW8N450026GC-00	450	10/5	12	0,65-0,77	140-160	120-140	
28	3SW8M350028GA-00	350	8/4	12,5	0,55-0,67	140-160	120-140	
	3SW8M450028GC-00	450	10/5	12,5	0,65-0,77	140-160	120-140	
30	3SW8M350030GA-00	350	8/4	13,5	0,53-0,65	140-160	120-140	
	3SW8M450030GC-00	450	10/5	13,5	0,63-0,75	140-160	120-140	
32	3SW8M400032GA-00	400	8/4	14,5	0,58-0,68	140-160	120-140	
	3SW8M500032GC-00	500	10/5	14,5	0,65-0,75	140-160	120-140	
34	3SW8N400034GA-00	400	8/4	15,5	0,55-0,65	140-160	120-140	
	3SW8N500034GC-00	500	10/5	15,5	0,60-0,70	140-160	120-140	
36	3SW8N400036GA-00	400	8/4	16,5	0,55-0,65	140-160	120-140	
	3SW8N500036GC-00	500	10/5	16,5	0,60-0,70	140-160	120-140	

Die angegebenen Werte sind eine Empfehlung, die wir natürlich den Gegebenheiten vor Ort anpassen bzw. entsprechend optimieren.
 The indicated cutting data can only be a recommendation and must be adapted on location and, if necessary, optimized.

Allgemeine Beschreibung / General Description

Das Fertigfräsen von Verzahnungen wird seit vielen Jahren weltweit erfolgreich mit Ingersoll Werkzeugen praktiziert. Dabei werden Werkzeuge mit formgeschliffenen Wendeschneidplatten mit konvexer (Innenverzahnung) oder konkaver (Außenverzahnung) Form verwendet. Die Werkzeuge, wie auch die Wendeschneidplatten, liegen innerhalb engster Toleranzen, um die geforderten Genauigkeiten der Zahnücke zu erzielen. Bei der Bearbeitung der Zahnücke wird zum einen im Zahngrund viel Material abgetragen, zum anderen erfolgt im Evolventenbereich dagegen eher ein Schlichtabtrag und ein Glätten der Oberfläche.

Diese komplexe Bearbeitung war Grund genug, ein Werkzeugkonzept zu entwickeln, welches den unterschiedlichen Schneidanforderungen gerecht wird. Entstanden ist ein Werkzeug mit unterschiedlichen Radialwinkeln und sich überlappenden Wendeschneidplattengeometrien.

Die neuen Werkzeuge erhalten im Bereich des Zahnfußes voll-effektive, und an der Zahnflanke halb-effektive Zähne, wodurch die Spanstärke optimiert wird. Die Vorteile des Ingersoll Designs spiegeln sich in einer erhöhten Standzeit, besserer Oberflächenqualität, geringerer Wärmeentwicklung am Bauteil, sowie einer Reduzierung der Schneidstoffkosten wieder.



The finishing of gears has been practiced successfully with Ingersoll tools for many years now. For the finishing operation all over the world tools with a convex (internal gear production) or concave (external gear production) form are applied. The tools, as well as the inserts are within very narrow tolerances to achieve the required accuracy of the tooth gap. During the machining of the tooth gap, a lot of material is removed from the tooth base, whereas in the involute area rather a finishing operation and polishing of the surface are carried out.

This complex machining operation was reason enough to develop a tool concept suitable for the various cutting requirements. The result is a tool with different radial angles as well as overlapping insert geometries.

These new tools obtain fully effective teeth at the root of the tooth and half effective teeth at the tooth flank thus optimizing the chip thickness. The advantages of this Ingersoll design are reflected in a longer tool life, improved surface finish, lower heat development on the component, as well as in a reduction of the cutting material costs.





Fertigfräser mit formgeschliffenen Wendeschneidplatten
 Außenring Modul 20; Werkstoff: 42CrMo4
 Schlichtbearbeitung (2. Schnitt)

$D = 290 \text{ mm}$ $n = 132 \text{ min}^{-1}$
 $fz = 0,4 \text{ mm}$ $vf = 520 \text{ mm/min}$
 $ae = 2 \text{ mm}$

Finishing gasher with profile ground inserts
 Outer ring module 20; material: 42CrMo4 finishing (2nd cut)

$D = 290 \text{ mm}$ $n = 132 \text{ rpm}$
 $fz = 0,4 \text{ mm}$ $vf = 520 \text{ mm/min}$
 $ae = 2 \text{ mm}$



Fertigfräser mit formgeschliffenen Wendeschneidplatten
 Innenring Modul 10; Werkstoff: 42CrMo4 Schlichtbearbeitung

$D = 380 \text{ mm}$ $n = 140 \text{ min}^{-1}$
 $fz = 0,45 \text{ mm}$ $vf = 785 \text{ mm/min}$
 $ae = 22,5 \text{ mm}$

Finishing gasher with profile ground inserts
 Inner ring module 10; material: 42CrMo4 finishing

$D = 380 \text{ mm}$ $n = 140 \text{ rpm}$
 $fz = 0,45 \text{ mm}$ $vf = 785 \text{ mm/min}$
 $ae = 22,5 \text{ mm}$



ZAHNFORMSCHLICHTFRÄSER MIT 2-SCHNEIDIGER PROFIL-WSP (INNEN)

GEAR FINISHING GASHER WITH 2-EDGED PROFILE GROUND INSERT (INTERNAL)



Fräser mit Quernut
Cutter with radial keyway

DIN 138

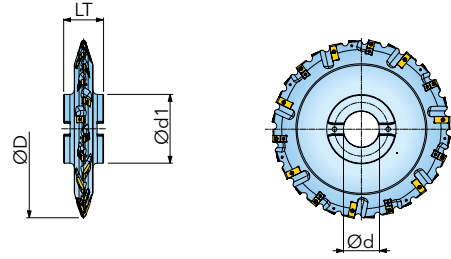

Modul Module	Artikel-Nr. Designation	D	d	LT	Z	Zeff.	d1	Passende WSP Fitting insert
6	37W8Z300006GA-I	300	80	90	24	12/6	160	A B
	37W8Z360006GA-I	360	80	90	28	14/7	170	A B
	37W8Z420006GA-I	420	80	90	32	16/8	180	A B
8	37W8Z300008GA-I	300	80	90	24	12/6	160	C D
	37W8Z360008GA-I	360	80	90	28	14/7	170	C D
	37W8Z420008GA-I	420	80	90	32	16/8	180	C D
10	37W8Z300010GA-I	300	80	90	24	12/6	160	E F
	37W8Z360010GA-I	360	80	90	28	14/7	170	E F
	37W8Z420010GA-I	420	80	90	32	16/8	180	E F
12	37W8Z300012GA-I	300	80	90	24	12/6	160	G H
	37W8Z360012GA-I	360	80	90	28	14/7	170	G H
	37W8Z420012GA-I	420	80	90	32	16/8	180	G H
14	37W8Z300014GA-I	300	80	90	24	12/6	160	I J
	37W8Z360014GA-I	360	80	90	28	14/7	170	I J
	37W8Z420014GA-I	420	80	90	32	16/8	180	I J
16	37W8Z300016GA-I	300	80	90	24	12/6	160	K L
	37W8Z360016GA-I	360	80	90	28	14/7	170	K L
	37W8Z420016GA-I	420	80	90	32	16/8	180	K L
18	37W8Z300018GA-I	300	80	90	24	12/6	160	M N
	37W8Z360018GA-I	360	80	90	28	14/7	170	M N
	37W8Z420018GA-I	420	80	90	32	16/8	180	M N
20	37W8Z300020GA-I	300	80	90	24	12/6	150	O P
	37W8Z360020GA-I	360	80	90	28	14/7	170	O P
	37W8Z420020GA-I	420	80	90	32	16/8	180	O P
22	37W8Z300022GA-I	300	80	90	24	12/6	150	Q R
	37W8Z360022GA-I	360	80	90	28	14/7	170	Q R
	37W8Z420022GA-I	420	80	90	32	16/8	180	Q R

ZUBEHÖR / SPARE PARTS

Senkschraube / Insert screw

SM40-090-00

für Platten / for inserts:

A B D F



Senkschraube / Insert screw

SM50-100-00

für Platten / for inserts:

C H



Senkschraube / Insert screw

SM50-140-10

für Platten / for inserts:

E G I J



Senkschraube / Insert screw

SM50-160-10

für Platten / for inserts:

K L M N O P Q R



WENDESCHNEIDPLATTEN / INSERTS

A FNC332-I-MOD6

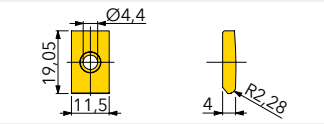

B LNA332-MOD6

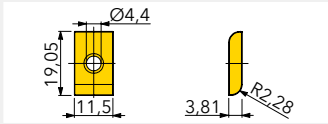

C FNC443-I-MOD8

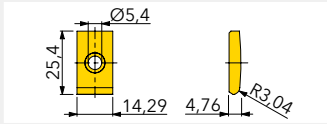

D LNA332-MOD8

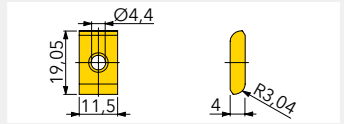

E FNC444-I-MOD10

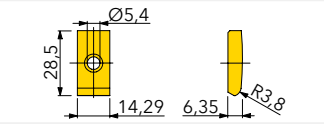

F LNA333-MOD10

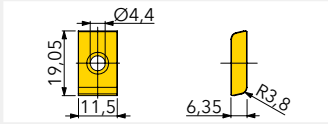

G FNC464-I-MOD12

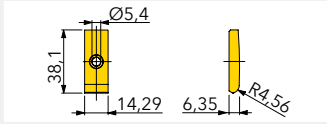

H LNA434-MOD12

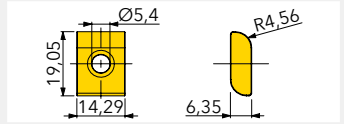

I FNC465-I-MOD14

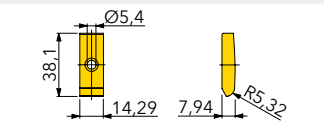

J LNA444-MOD14

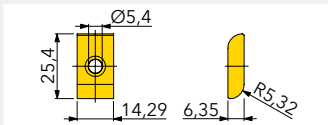

K FNC475-I-MOD16

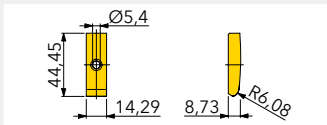

L LNA454-MOD16

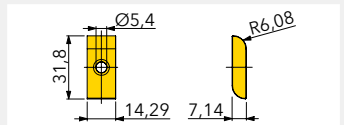

M FNC485-I-MOD18

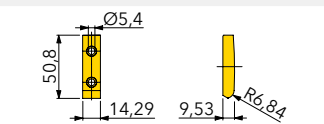

N LNA454-MOD18

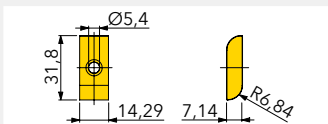

O FNC496-I-MOD20

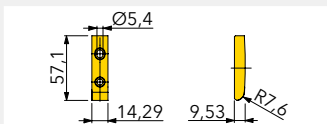

P LNA446-MOD20

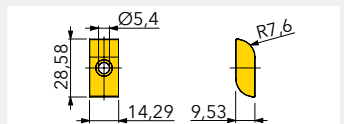

Q FNC4106-I-MOD22

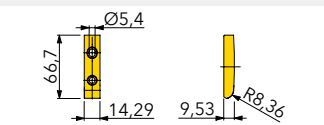

R LNA446-MOD22

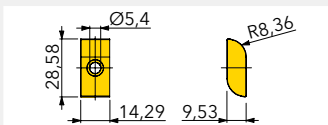

Artikel-Nr. Designation	Ausführung Description	Qualität Grade	IN2040	IN2505	IN2530
FNC_	negative Geometrie / negative geometry				
LNA_	negative Geometrie / negative geometry				

● = P ● = M ● = K ● = N ● = S ○ = H

ZAHNFORMSCHLICHTFRÄSER MIT 2-SCHNEIDIGER PROFIL-WSP (AUSSEN) GEAR FINISHING GASHER WITH 2-EDGED PROFILE GROUND INSERT (EXTERNAL)



Fräser mit Quernut
Cutter with radial keyway

DIN 138

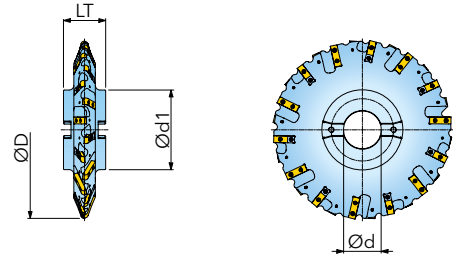

Modul Module	Artikel-Nr. Designation	D	d	LT	Z	Zeff.	d1	Passende WSP Fitting insert
6	37W8Z300006GA-A	300	80	90	24	12/6	160	A B
	37W8Z360006GA-A	360	80	90	28	14/7	170	A B
	37W8Z420006GA-A	420	80	90	32	16/8	180	A B
8	37W8Z300008GA-A	300	80	90	24	12/6	160	C D
	37W8Z360008GA-A	360	80	90	28	14/7	170	C D
	37W8Z420008GA-A	420	80	90	32	16/8	180	C D
10	37W8Z300010GA-A	300	80	90	24	12/6	160	E F
	37W8Z360010GA-A	360	80	90	28	14/7	170	E F
	37W8Z420010GA-A	420	80	90	32	16/8	180	E F
12	37W8Z300012GA-A	300	80	90	24	12/6	160	G H
	37W8Z360012GA-A	360	80	90	28	14/7	170	G H
	37W8Z420012GA-A	420	80	90	32	16/8	180	G H
14	37W8Z300014GA-A	300	80	90	24	12/6	160	I J
	37W8Z360014GA-A	360	80	90	28	14/7	170	I J
	37W8Z420014GA-A	420	80	90	32	16/8	180	I J
16	37W8Z300016GA-A	300	80	90	24	12/6	160	K L
	37W8Z360016GA-A	360	80	90	28	14/7	170	K L
	37W8Z420016GA-A	420	80	90	32	16/8	180	K L
18	37W8Z300018GA-A	300	80	90	24	12/6	160	M N
	37W8Z360018GA-A	360	80	90	28	14/7	170	M N
	37W8Z420018GA-A	420	80	90	32	16/8	180	M N
20	37W8Z300020GA-A	300	80	90	24	12/6	160	O P
	37W8Z360020GA-A	360	80	90	28	14/7	170	O P
	37W8Z420020GA-A	420	80	90	32	16/8	180	O P
22	37W8Z300022GA-A	300	80	90	24	12/6	160	Q R
	37W8Z360022GA-A	360	80	90	28	14/7	170	Q R
	37W8Z420022GA-A	420	80	90	32	16/8	180	Q R

ZUBEHÖR / SPARE PARTS

Senkschraube / Insert screw

SM40-090-00

für Platten / for inserts:

A B D F



Senkschraube / Insert screw

SM50-100-00

für Platten / for inserts:

C H



Senkschraube / Insert screw

SM50-140-10

für Platten / for inserts:

E G I J



Senkschraube / Insert screw

SM50-160-10

für Platten / for inserts:

K L M N O P Q R



WENDESCHNEIDPLATTEN / INSERTS

A FNC332-A-MOD6



Fuß Root

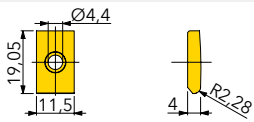

B LNA332-MOD6



Fuß Root

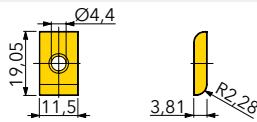

C FNC443-A-MOD8



Flanke Flank

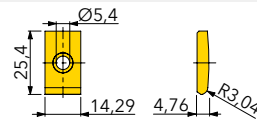

D LNA332-MOD8



Fuß Root

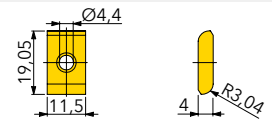

E FNC444-A-MOD10



Flanke Flank

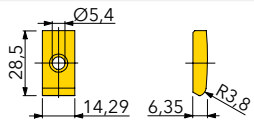

F LNA333-MOD10



Fuß Root

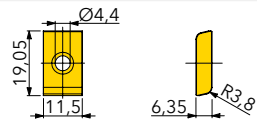

G FNC464-A-MOD12



Flanke Flank

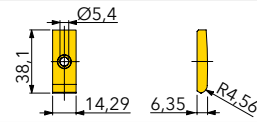

H LNA434-MOD12



Fuß Root

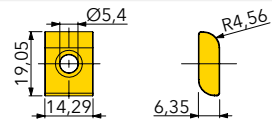

I FNC465-A-MOD14



Flanke Flank

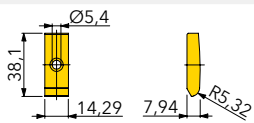

J LNA444-MOD14



Fuß Root

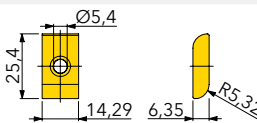

K FNC475-A-MOD16



Flanke Flank

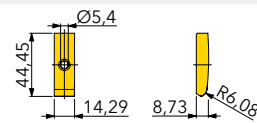

L LNA454-MOD16



Fuß Root

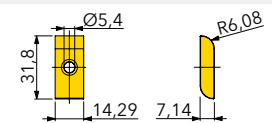

M FNC485-A-MOD18



Flanke Flank

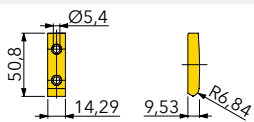

N LNA454-MOD18



Fuß Root

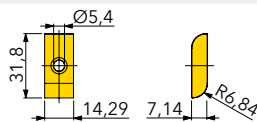

O FNC496-A-MOD20



Flanke Flank

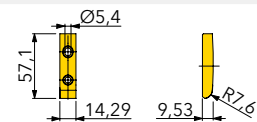

P LNA446-MOD20



Fuß Root

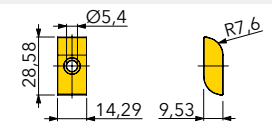

Q FNC4106-A-MOD22



Flanke Flank

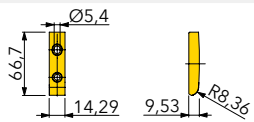

R LNA446-MOD22



Fuß Root

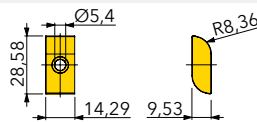

Artikel-Nr.
Designation

Ausführung
Description

Qualität
Grade

IN2040 IN2505 IN2530

FNC_ negative Geometrie / negative geometry

LNA_ negative Geometrie / negative geometry

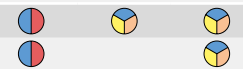

● = P ● = M ● = K ● = N ● = S ○ = H

ZAHNFORMSCHLICHTFRÄSER MIT 4-SCHNEIDIGER PROFIL-WSP (INNEN) GEAR FINISHING GASHER WITH 4-EDGED PROFILE GROUND INSERT (INTERNAL)



Fräser mit Quernut
Cutter with radial keyway

DIN 138

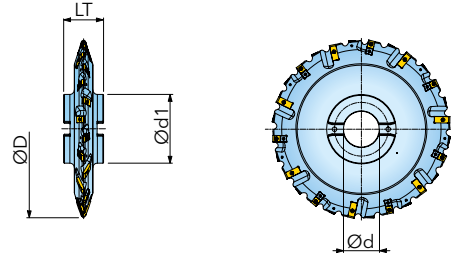

Modul Module	Artikel-Nr. Designation	D	d	LT	z	Zeff.	d1	Passende WSP Fitting insert
6	37W8Z300406GA-I	300	80	90	24	12/6	160	A B
	37W8Z360406GA-I	360	80	90	28	14/7	170	A B
	37W8Z420406GA-I	420	80	90	32	16/8	180	A B
8	37W8Z300408GA-I	300	80	90	24	12/6	160	C D
	37W8Z360408GA-I	360	80	90	28	14/7	170	C D
	37W8Z420408GA-I	420	80	90	32	16/8	180	C D
10	37W8Z300410GA-I	300	80	90	24	12/6	160	E F
	37W8Z360410GA-I	360	80	90	28	14/7	170	E F
	37W8Z420410GA-I	420	80	90	32	16/8	180	E F
12	37W8Z300412GA-I	300	80	90	24	12/6	160	G H
	37W8Z360412GA-I	360	80	90	28	14/7	170	G H
	37W8Z420412GA-I	420	80	90	32	16/8	180	G H
14	37W8Z300414GA-I	300	80	90	24	12/6	160	I J
	37W8Z360414GA-I	360	80	90	28	14/7	170	I J
	37W8Z420414GA-I	420	80	90	32	16/8	180	I J
16	37W8Z300416GA-I	300	80	90	24	12/6	160	K L
	37W8Z360416GA-I	360	80	90	28	14/7	170	K L
	37W8Z420416GA-I	420	80	90	32	16/8	180	K L
18	37W8Z300418GA-I	300	80	90	24	12/6	160	M N
	37W8Z360418GA-I	360	80	90	28	14/7	170	M N
	37W8Z420418GA-I	420	80	90	32	16/8	180	M N

ZUBEHÖR / SPARE PARTS

Senkschraube / Insert screw

SM40-090-00

für Platten / for inserts:
B D



Senkschraube / Insert screw

SM40-110-00

für Platten / for inserts:
A C F



Senkschraube / Insert screw

SM50-140-10

für Platten / for inserts:
E G H I J



Senkschraube / Insert screw

SM50-160-10

für Platten / for inserts:
K L M N



WENDESCHNEIDPLATTEN / INSERTS

<p>A QNC344-I-MOD6</p>  <p>Flanke Flank</p> 	<p>B LNA332-MOD6</p>  <p>Fuß Root</p> 	<p>C QNC344-I-MOD8</p>  <p>Flanke Flank</p> 	<p>D LNA332-MOD8</p>  <p>Fuß Root</p> 
<p>E QNC454-I-MOD10</p>  <p>Flanke Flank</p> 	<p>F LNA333-MOD10</p>  <p>Fuß Root</p> 	<p>G QNC464-I-MOD12</p>  <p>Flanke Flank</p> 	<p>H LNA434-MOD12</p>  <p>Fuß Root</p> 
<p>I QNC464-I-MOD14</p>  <p>Flanke Flank</p> 	<p>J LNA444-MOD14</p>  <p>Fuß Root</p> 	<p>K QNC475-I-MOD16</p>  <p>Flanke Flank</p> 	<p>L LNA454-MOD16</p>  <p>Fuß Root</p> 
<p>M QNC486-I-MOD18</p>  <p>Flanke Flank</p> 	<p>N LNA454-MOD18</p>  <p>Fuß Root</p> 		

Artikel-Nr. Designation	Ausführung Description	Qualität Grade	IN2040	IN2530
LNA_	negative Geometrie / negative geometry			
QNC_	negative Geometrie / negative geometry			

● = P ● = M ● = K ● = N ● = S ○ = H

ZAHNFORMSCHLICHTFRÄSER MIT 4-SCHNEIDIGER PROFIL-WSP (AUSSEN) GEAR FINISHING GASHER WITH 4-EDGED PROFILE GROUND INSERT (EXTERNAL)



Fräser mit Quernut
Cutter with radial keyway

DIN 138

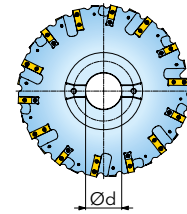
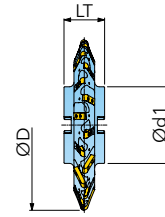

Modul Module	Artikel-Nr. Designation	D	d	LT	z	Zeff.	d1	Passende WSP Fitting insert
6	37W8Z300406GA-A	300	80	90	24	12/6	160	A B
	37W8Z360406GA-A	360	80	90	28	14/7	170	A B
	37W8Z420406GA-A	420	80	90	32	16/8	180	A B
8	37W8Z300408GA-A	300	80	90	24	12/6	160	C D
	37W8Z360408GA-A	360	80	90	28	14/7	170	C D
	37W8Z420408GA-A	420	80	90	32	16/8	180	C D
10	37W8Z300410GA-A	300	80	90	24	12/6	160	E F
	37W8Z360410GA-A	360	80	90	28	14/7	170	E F
	37W8Z420410GA-A	420	80	90	32	16/8	180	E F
12	37W8Z300412GA-A	300	80	90	24	12/6	160	G H
	37W8Z360412GA-A	360	80	90	28	14/7	170	G H
	37W8Z420412GA-A	420	80	90	32	16/8	180	G H
14	37W8Z300414GA-A	300	80	90	24	12/6	160	I J
	37W8Z360414GA-A	360	80	90	28	14/7	170	I J
	37W8Z420414GA-A	420	80	90	32	16/8	180	I J
16	37W8Z300416GA-A	300	80	90	24	12/6	160	K L
	37W8Z360416GA-A	360	80	90	28	14/7	170	K L
	37W8Z420416GA-A	420	80	90	32	16/8	180	K L
18	37W8Z300418GA-A	300	80	90	24	12/6	160	M N
	37W8Z360418GA-A	360	80	90	28	14/7	170	M N
	37W8Z420418GA-A	420	80	90	32	16/8	180	M N

ZUBEHÖR / SPARE PARTS

Senkschraube / Insert screw

SM40-090-00

für Platten / for inserts:

B D



Senkschraube / Insert screw

SM40-110-00

für Platten / for inserts:

A C F



Senkschraube / Insert screw

SM50-140-10

für Platten / for inserts:

E G H I J



Senkschraube / Insert screw

SM50-160-10

für Platten / for inserts:





K L M N



WENDESCHNEIDPLATTEN / INSERTS

<p>A QNC344-A-MOD6</p>  <p>Flanke Flank</p> 	<p>B LNA332-MOD6</p>  <p>Fuß Root</p> 	<p>C QNC344-A-MOD8</p>  <p>Flanke Flank</p> 	<p>D LNA332-MOD8</p>  <p>Fuß Root</p> 
<p>E QNC454-A-MOD10</p>  <p>Flanke Flank</p> 	<p>F LNA333-MOD10</p>  <p>Fuß Root</p> 	<p>G QNC464-A-MOD12</p>  <p>Flanke Flank</p> 	<p>H LNA434-MOD12</p>  <p>Fuß Root</p> 
<p>I QNC464-A-MOD14</p>  <p>Flanke Flank</p> 	<p>J LNA444-MOD14</p>  <p>Fuß Root</p> 	<p>K QNC475-A-MOD16</p>  <p>Flanke Flank</p> 	<p>L LNA454-MOD16</p>  <p>Fuß Root</p> 
<p>M QNC486-A-MOD18</p>  <p>Flanke Flank</p> 	<p>N LNA454-MOD18</p>  <p>Fuß Root</p> 		

QNC-Wendeschneidplatte für Aussenzahnräder mit Zahnzahlen > 50 geeignet.
 QNC insert usable for external gears with no. of teeth > 50.

Artikel-Nr. Designation	Ausführung Description	Qualität Grade	IN2040	IN2530
LNA_	negative Geometrie / negative geometry			
QNC_	negative Geometrie / negative geometry			

● = P ● = M ● = K ● = N ● = S ○ = H

SCHNITTWERTEMPFEHLUNG ZAHNFORMSCHLICHTFRÄSER (INNEN/AUSSEN) CUTTING DATA RECOMMENDATION FINISHING GASHER (INTERNAL/EXTERNAL)



Modul Module	Artikel-Nr. Designation	D [mm]	Zeff.	ae1 [mm] Schnitt1/cut1	fz1 [mm] Schnitt1/cut1	Vc1 [m/min] Rm<1000 N/mm2	Vc1 [m/min] Rm>1000 N/mm2
6	37W8Z300006GA-I/E	300	12/6	13,5	0,50-0,60	160-180	140-160
	37W8Z360006GA-I/E	360	14/7	13,5	0,55-0,65	160-180	140-160
	37W8Z420006GA-I/E	420	16/8	13,5	0,58-0,72	160-180	140-160
8	37W8Z300008GA-I/E	300	12/6	18,0	0,42-0,52	160-180	140-160
	37W8Z360008GA-I/E	360	14/7	18,0	0,48-0,58	160-180	140-160
	37W8Z420008GA-I/E	420	16/8	18,0	0,52-0,62	160-180	140-160
10	37W8Z300010GA-I/E	300	12/6	22,5	0,38-0,48	150-170	130-150
	37W8Z360010GA-I/E	360	14/7	22,5	0,42-0,52	150-170	130-150
	37W8Z420010GA-I/E	420	16/8	22,5	0,45-0,55	150-170	130-150
12	37W8Z300012GA-I/E	300	12/6	27,0	0,35-0,45	150-170	130-150
	37W8Z360012GA-I/E	360	14/7	27,0	0,38-0,48	150-170	130-150
	37W8Z420012GA-I/E	420	16/8	27,0	0,42-0,52	150-170	130-150
14	37W8Z300014GA-I/E	300	12/6	31,5	0,32-0,42	150-170	130-150
	37W8Z360014GA-I/E	360	14/7	31,5	0,35-0,45	150-170	130-150
	37W8Z420014GA-I/E	420	16/8	31,5	0,38-0,48	150-170	130-150
16	37W8Z300016GA-I/E	300	12/6	36,0	0,30-0,40	140-160	120-140
	37W8Z360016GA-I/E	360	14/7	36,0	0,32-0,42	140-160	120-140
	37W8Z420016GA-I/E	420	16/8	36,0	0,36-0,46	140-160	120-140
18	37W8Z300018GA-I/E	300	12/6	37,5	0,30-0,38	140-160	120-140
	37W8Z360018GA-I/E	360	14/7	37,5	0,32-0,42	140-160	120-140
	37W8Z420018GA-I/E	420	16/8	37,5	0,35-0,45	140-160	120-140
20	37W8Z300020GA-I/E	300	12/6	41,0	0,29-0,37	140-160	120-140
	37W8Z360020GA-I/E	360	14/7	41,0	0,32-0,40	140-160	120-140
	37W8Z420020GA-I/E	420	16/8	41,0	0,34-0,42	140-160	120-140
22	37W8Z300022GA-I/E	300	12/6	44,5	0,29-0,35	120-140	100-120
	37W8Z360022GA-I/E	360	14/7	44,5	0,30-0,38	120-140	100-120
	37W8Z420022GA-I/E	420	16/8	44,5	0,32-0,42	120-140	100-120

Modul Module	Artikel-Nr. Designation	D [mm]	Zeff.	ae2 [mm] Schnitt2/cut2	fz2 [mm] Schnitt2/cut2	Vc2 [m/min] Rm<1000 N/mm2	Vc2 [m/min] Rm>1000 N/mm2	
6	37W8Z300006GA-I/E	300	12/6	-	-	-	-	Bearbeitung in einem Schnitt Machining in one cut
	37W8Z360006GA-I/E	360	14/7	-	-	-	-	
	37W8Z420006GA-I/E	420	16/8	-	-	-	-	
8	37W8Z300008GA-I/E	300	12/6	-	-	-	-	Bearbeitung in einem Schnitt Machining in one cut
	37W8Z360008GA-I/E	360	14/7	-	-	-	-	
	37W8Z420008GA-I/E	420	16/8	-	-	-	-	
10	37W8Z300010GA-I/E	300	12/6	-	-	-	-	Bearbeitung in einem Schnitt Machining in one cut
	37W8Z360010GA-I/E	360	14/7	-	-	-	-	
	37W8Z420010GA-I/E	420	16/8	-	-	-	-	
12	37W8Z300012GA-I/E	300	12/6	-	-	-	-	Bearbeitung in einem Schnitt Machining in one cut
	37W8Z360012GA-I/E	360	14/7	-	-	-	-	
	37W8Z420012GA-I/E	420	16/8	-	-	-	-	
14	37W8Z300014GA-I/E	300	12/6	-	-	-	-	Bearbeitung in einem Schnitt Machining in one cut
	37W8Z360014GA-I/E	360	14/7	-	-	-	-	
	37W8Z420014GA-I/E	420	16/8	-	-	-	-	
16	37W8Z300016GA-I/E	300	12/6	-	-	-	-	Bearbeitung in einem Schnitt Machining in one cut
	37W8Z360016GA-I/E	360	14/7	-	-	-	-	
	37W8Z420016GA-I/E	420	16/8	-	-	-	-	
18	37W8Z300018GA-I/E	300	12/6	3,0	0,8-1,0	160-180	140-160	Bearbeitung in zwei Schnitten Machining in two cuts
	37W8Z360018GA-I/E	360	14/7	3,0	0,9-1,1	160-180	140-160	
	37W8Z420018GA-I/E	420	16/8	3,0	1,0-1,2	160-180	140-160	
20	37W8Z300020GA-I/E	300	12/6	4,0	0,8-1,0	160-180	140-160	Bearbeitung in zwei Schnitten Machining in two cuts
	37W8Z360020GA-I/E	360	14/7	4,0	0,9-1,1	160-180	140-160	
	37W8Z420020GA-I/E	420	16/8	4,0	1,0-1,2	160-180	140-160	
22	37W8Z300022GA-I/E	300	12/6	5,0	0,8-1,0	140-160	120-140	Bearbeitung in zwei Schnitten Machining in two cuts
	37W8Z360022GA-I/E	360	14/7	5,0	0,9-1,1	140-160	120-140	
	37W8Z420022GA-I/E	420	16/8	5,0	1,0-1,2	140-160	120-140	

Die angegebenen Werte sind eine Empfehlung, die wir natürlich den Gegebenheiten vor Ort anpassen bzw. entsprechend optimieren.
The indicated cutting data can only be a recommendation and must be adapted on location and, if necessary, optimized.

GEWINDEZIRKULARFRÄSER 17Y1...X THREAD MILL 17Y1...X

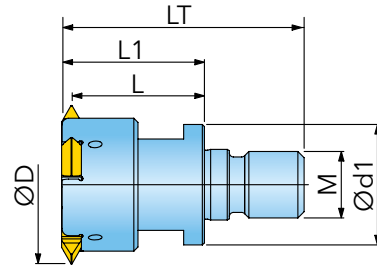

Artikel-Nr. Designation	D	d1	LT	L	L1	M	Z	WSP	IK	kg	Passende WSP Related Insert
17Y1B041055X8R00	40,7	29	58,381	32	34,3	M16	4	LZA323-MOD1	✓	0,20	A
17Y1E051064X8R00	50,7	29	69,175	42	45,1	M16	4	LZA434-MOD2	✓	0,31	B

GEWINDEZIRKULARFRÄSER 17Y1...Z THREAD MILL 17Y1...Z

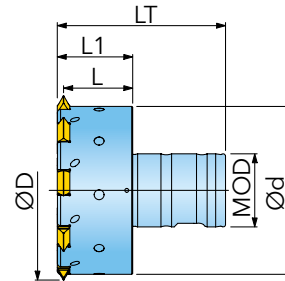

Artikel-Nr. Designation	D	d	LT	L	L1	MOD	Z	WSP	IK	kg	Passende WSP Related Insert
17Y1E060064Z4R00	59,7	50	73,175	35	38,1	40	5	LZA434-MOD2	✓	1,10	B
17Y1E080064Z4R00	79,7	69	73,175	35	38,1	40	8	LZA434-MOD2	✓	0,62	B
17Y1E096064Z5R00	95,7	85	85,175	35	38,1	50	9	LZA434-MOD2	✓	1,80	B
17Y1E112064Z5R00	111,7	101	95,175	45	48,1	50	11	LZA434-MOD2	✓	3,10	B
17Y1L112010Z5R00	111,1	95,5	96,763	45	49,7	50	11	LZA436-MOD3	✓	2,70	C

A LZA323-MOD1

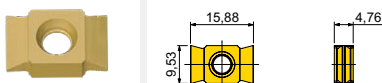

B LZA434-MOD2

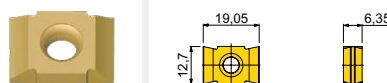

C LZA446-MOD3

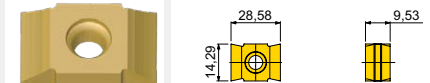

Artikel-Nr. Designation	Ausführung Description	Qualität Grade	IN2040
LZA323-MOD1	Modulbereich ≤ 1 mm / module range ≤ 1 mm		<input type="radio"/>
LZA434-MOD2	Modulbereich 1 - 2 mm / module range 1 to 2 mm		<input type="radio"/>
LZA446-MOD3	Modulbereich 2 - 3 mm / module range 2 to 3 mm		<input type="radio"/>

Ausführung der Profilschneiden gemäß den Verzahnungsdaten.
Design of profile inserts depends on gear data.

● = P ● = M ● = K ● = N ● = S ○ = H

ZUBEHÖR SPARE PARTS

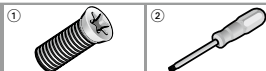

WSP-Typ / Insert

LZA323-MOD1	SM40-090-00	DS-T15S
LZA434-MOD2	SM50-160-00	DS-T15S
LZA446-MOD3	SM50-160-00	DS-T15S

① = Spanschraube / insert screw ② = Schraubendreher / screw driver

A large rectangular area filled with a grid of small, empty squares, intended for writing notes. The grid consists of approximately 30 columns and 40 rows of squares.



Allgemeine Beschreibung / General Description

Die Ingersoll Wälzfräser sind das Ergebnis kontinuierlicher Weiterentwicklung durch unsere Ingenieure. Die Erfahrungen und Wünsche unserer Kunden wurden bei den Entwicklungen und Konzeptionen sorgfältig einbezogen. Mit diesen Werkzeugen ist die wirtschaftliche Bearbeitungen von Zahnrädern ab Modul 6 möglich. Durch den Einsatz von Hartmetall-Wendeschneidplatten können mit hohen Schnittgeschwindigkeiten große Zerspanvolumen realisiert werden.

The Ingersoll hobs are the result of continuous further development by our engineers. The experience and individual requirements of our customers were carefully included in the development and conception. These tools allow an economical machining of gears from module 6 and upwards. With the application of carbide inserts a high chip removal can be achieved at high cutting speeds.

Ingersoll Wälzfräser bestehen aus einzelnen Segmenten, die durch hochgenaue Kreuznuten positioniert werden. Durch große Passflächen erzielen wir eine gute, formschlüssige Abstützung der einzelnen Segmente in der Spirale. Die Segmente werden über 2 Endscheiben mit Spannschrauben verbunden. Da eine 360°-Spirale ein Segment darstellt, werden die Fertigungstoleranzen innerhalb einer Umdrehung minimiert, was sich positiv auf die Güteklasse der Wälzfräser auswirkt. Mit dem Ingersoll Segment-Design ist eine Verlängerung des Werkzeuges – Vergrößerung der Schneidenlänge – relativ einfach möglich. Es werden lediglich längere Anzugsstangen benötigt. Des weiteren ist eine einfache Montage und Demontage der Segmente sichergestellt.

Ingersoll hobs consist of individual segments which are positioned by means of high-precision cross slots. Large fitting surfaces allow us form-fit support of each segment in the spiral. These segments are connected with clamping screws via two end caps. Because a 360° spiral forms a segment, the production tolerances within one rotation are minimized, which has a positive effect on the quality class of the hobs. The Ingersoll segment design makes an extension of the tool - an enlargement of the cutting length - comparatively simple. Only longer pull bars are required. Moreover, easy assembly and disassembly is guaranteed.

Mit der Weiterentwicklung der Wendeschneidplatten – WSP mit schräger Bohrung – konnte die Problematik des Wendeschneidplattenwechsels gelöst werden. Es ist nunmehr möglich, die Wendeschneidplatte im zusammengebauten Wälzfräser mit einem Standard-Schraubendreher zu wechseln. Ein weiterer Vorteil besteht darin, dass durch die Schrägbohrung die Lage der Wendeschneidplatte genau definiert ist. Die Wendeschneidplatte kann nicht mehr versehentlich falsch eingebaut werden. Darüber hinaus erzielen wir durch die Schrägstellung der Senkschraube einen größeren Gewindetrageanteil, die den Wendeschneidplattensitz – und damit das Werkzeug – stabilisiert.

With the further development of the insert with an inclined bore the problem of exchanging an insert has also been solved. It is now possible to exchange the insert with a standard screwdriver while the hob is assembled. A further advantage is that the position of the insert can be exactly defined because of the inclined bore. The insert can no longer be inadvertently assembled incorrectly. Furthermore, a larger thread percentage contact area can be achieved thanks to this inclined position of the insert screw which stabilizes the insert pocket as well as the tool itself.

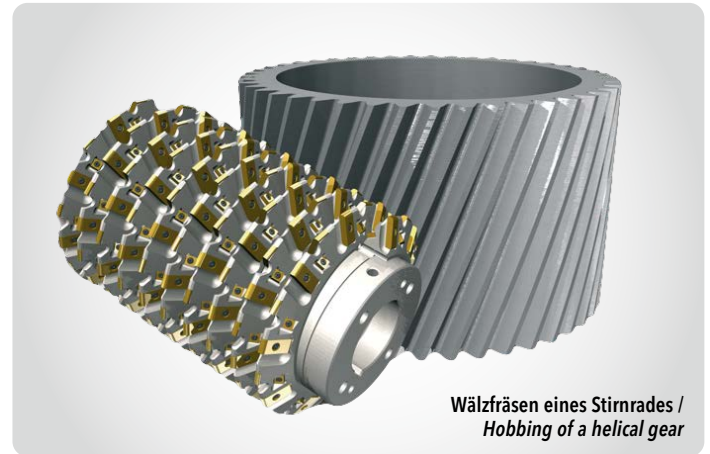

Wälzfräsen eines Stirnrades /
Hobbing of a helical gear

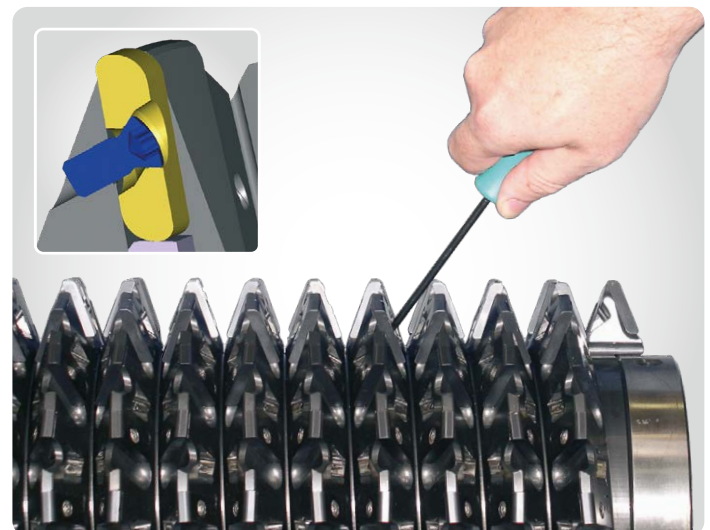
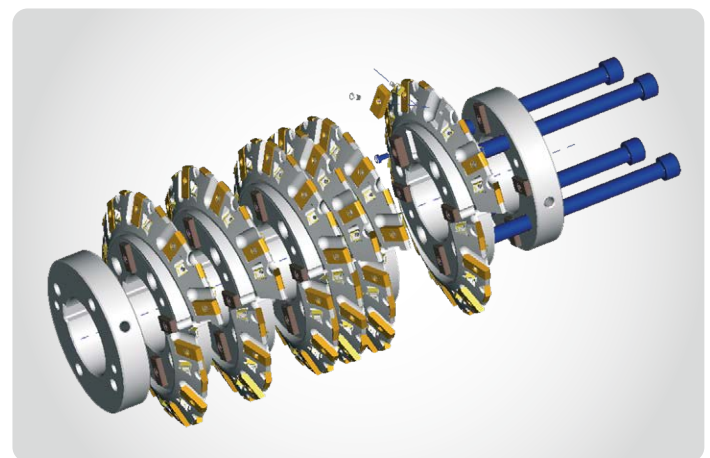

Definition der Bezugsprofile nach DIN 3972 / Definition of basic rack profiles acc. to DIN 3972

Bezugsprofil I / Für Fertigbearbeitung
Basic Rack Profile I / For finishing

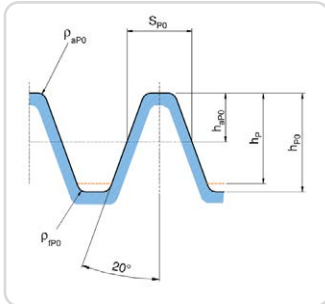

$$\begin{aligned} h_{aP0} &= 1,167 \times m \\ h_p &= 2,167 \times m \\ h_{P0} &= 2,367 \times m \\ \rho_{aP0} &\sim 0,2 \times m \\ \rho_{fP0} &\sim 0,2 \times m \\ S_{P0} &= \frac{\pi}{2} \times m \end{aligned}$$

Bezugsprofil II / Für Fertigbearbeitung
Basic Rack Profile II / For finishing

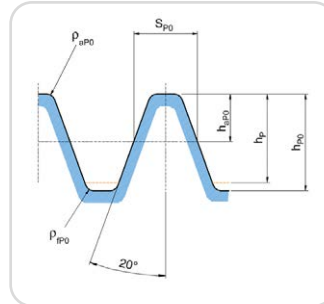

$$\begin{aligned} h_{aP0} &= 1,250 \times m \\ h_p &= 2,250 \times m \\ h_{P0} &= 2,450 \times m \\ \rho_{aP0} &\sim 0,2 \times m \\ \rho_{fP0} &\sim 0,2 \times m \\ S_{P0} &= \frac{\pi}{2} \times m \end{aligned}$$

Bezugsprofil III / Für Vorbereitung zum Schleifen oder Schaben
Basic Rack Profile III / Preshaping for grinding or shaving

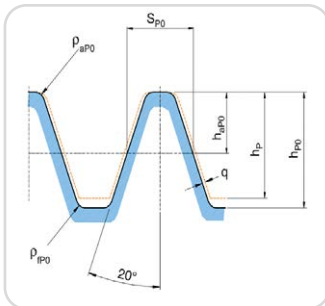

$$\begin{aligned} h_{aP0} &= 1,25 \times m + 0,25 \sqrt[3]{m} \\ h_p &= 2,250 \times m \\ h_{P0} &= 2,450 \times m \\ \rho_{aP0} &\sim 0,2 \times m \\ \rho_{fP0} &\sim 0,2 \times m \\ S_{P0} &= \frac{\pi}{2} \times m \\ q &= 0,25 \sqrt[3]{m} \times \sin 20^\circ \end{aligned}$$

Bezugsprofil IV / Für Vorbereitung zum Schlichten
Basic Rack Profile IV / Preshaping for finishing

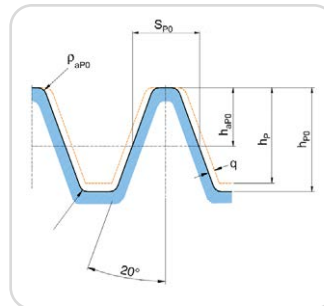

$$\begin{aligned} h_{aP0} &= 1,25 \times m + 0,60 \sqrt[3]{m} \\ h_p &= 2,250 \times m \\ h_{P0} &= 2,450 \times m \\ \rho_{aP0} &\sim 0,2 \times m \\ \rho_{fP0} &\sim 0,2 \times m \\ S_{P0} &= \frac{\pi}{2} \times m \\ q &= 0,6 \sqrt[3]{m} \times \sin 20^\circ \end{aligned}$$

Kurzzeichen Definition
Description of symbols

- h_{aP0} = Kopfhöhe des Bezugsprofils / *addendum*
- h_p = Profilhöhe des Rades = Frästiefe
= *tooth depth = cutting depth*
- h_{P0} = Profilhöhe des Bezugsprofils
= *tooth depth of the basic rack profile*
- S_{P0} = Zahndicke / *tooth thickness*
- ρ_{aP0} = Kopfrundungsradius / *tip radius*
- ρ_{fP0} = Fussrundungsradius / *root radius*

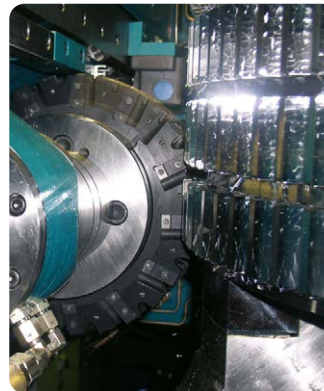

Fertigfräsen mit Wälzfräser
 Außenring Modul 10, $z = 94$
 Werkstoff: 42CrMo4

Finishing with hob
 Outer ring module 10, $z = 94$
 material: 42CrMo4

$D = 300 \text{ mm}$
 $n = 148 \text{ min}^{-1} [\text{rpm}]$
 $fa = 4 \text{ mm/WU} [\text{mm/rev.}]$
 $ae = 22,5 \text{ mm}$

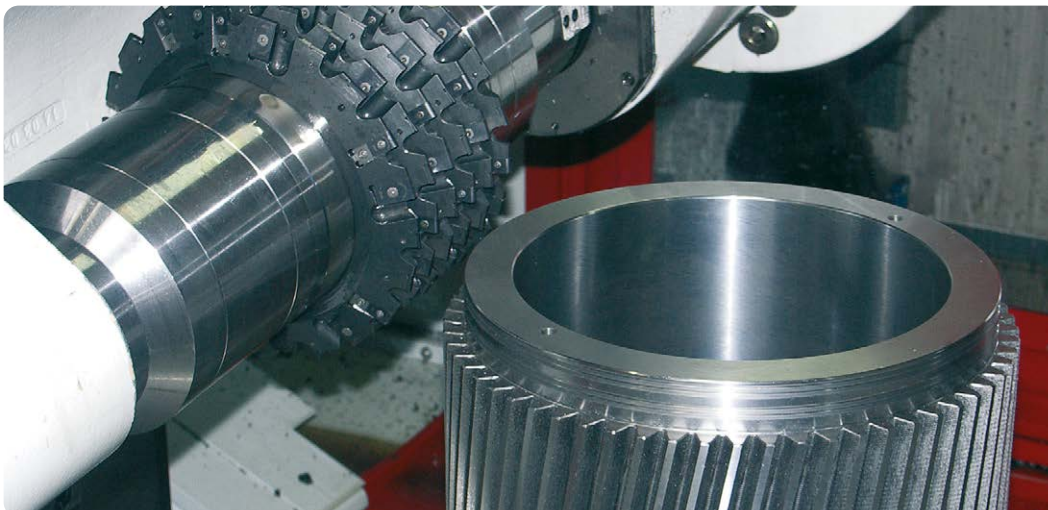

Vorfräsen mit Wälzfräser
 Stirnrad Modul 12, $z = 45$
 Werkstoff: 18CrMo6

Roughing with hob
 Spur gear module 12, $z = 45$
 material: 18CrMo6

$D = 270 \text{ mm}$
 $n = 140 \text{ min}^{-1} [\text{rpm}]$
 $fa = 3 \text{ mm/WU} [\text{mm/rev.}]$
 $ae = 28 \text{ mm}$

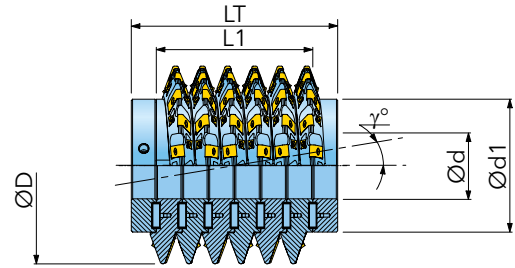

Modul Module	Artikel-Nr. Designation	D	d	Anz./no. Segm.	L1	LT	Zsegm.	Zges./total	d1	γ	Passende WSP Fitting insert
6	77X8Z180006BDA02	180	40	6	113	173	15	90	125	2,084	90x A
	77X8Z210006BEA02	210	50	6	113	173	17	102	125	1,763	102x A
	77X8Z240006BFA02	240	60	6	113	173	19	114	160	1,528	114x A
7	77X8Z180007BDA02	180	40	6	132	192	15	90	125	2,469	90x B
	77X8Z210007BEA02	210	50	6	132	192	17	102	125	2,084	102x B
	77X8Z240007BFA02	240	60	6	132	192	19	114	160	1,803	114x B
8	77X8Z210008BEA02	210	50	6	151	211	17	102	125	2,413	102x C
	77X8Z240008BFA02	240	60	6	151	211	19	114	160	2,084	114x C
	77X8Z270008BHA02	270	80	6	151	211	21	126	180	1,834	126x C
9	77X8Z210009BEA02	210	50	6	169	229	17	102	125	2,751	102x D
	77X8Z240009BFA02	240	60	6	169	229	19	114	160	2,372	114x D
	77X8Z270009BHA02	270	80	6	169	229	21	126	180	2,084	126x D
10	77X8Z210010BEA02	210	50	6	189	249	17	102	125	3,099	102x E
	77X8Z240010BFA02	240	60	6	189	249	19	114	160	2,666	114x E
	77X8Z270010BHA02	270	80	6	189	249	21	126	180	2,339	126x E
12	77X8Z240012BFA02	240	60	6	226	298	18	108	140	3,276	54x F 54x G
	77X8Z270012BHA02	270	80	6	226	298	22	132	180	2,866	66x F 66x G
	77X8Z350012BHA02	350	80	6	226	298	26	156	240	2,194	78x F 78x G
14	77X8Z270014BHA02	270	80	6	264	336	22	132	180	3,415	66x H 66x I
	77X8Z350014BHA02	350	80	6	264	336	26	156	240	2,547	78x H 78x I
16	77X8Z270016BHA02	270	80	6	302	375	22	132	160	3,989	66x J 66x K
	77X8Z350016BHA02	350	80	6	302	375	26	156	220	2,959	78x J 78x K
18	77X8Z270018BHA02	270	80	5	283	355	22	110	145	4,589	55x L 55x M
	77X8Z350018BHA02	350	80	5	283	355	26	130	220	3,383	65x L 65x M
20	77X8Z350020BHA02	350	80	5	314	386	26	130	220	3,823	65x N 65x O
	77X8Z450020BJA02	450	100	5	314	386	34	170	270	2,866	85x N 85x O

Wälzfräser werden im Allgemeinen eingängig rechtssteigend in der Güteklasse B nach DIN 3968 gefertigt. Wälzfräser linkssteigend, mehrgängig und in Güteklasse A auf Anfrage.
Hobs are generally produced in a single thread right-hand design in class B according to DIN 3968. Hobs in left-hand design, multiple thread and in class A on request.

ZUBEHÖR/SPARE PARTS

Senkschraube / Insert screw

SM40-090-00

für Platten / for inserts:

A B C D



Senkschraube / Insert screw

SM50-120-10

für Platten / for inserts:

E F G I K



Senkschraube / Insert screw

SM50-140-10

für Platten / for inserts:

H



Senkschraube / Insert screw

SM50-160-10

für Platten / for inserts:

J L M N O



WENDESCHNEIDPLATTEN / INSERTS

A FNC333-131-A

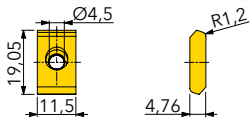

B FNC343-117-A

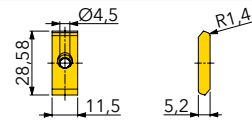

C FNC343-108-A

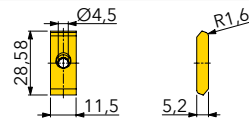

D FNC343-118-A

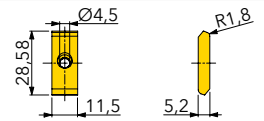

E FNC454-135-A

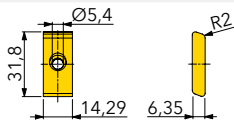

F FNC464-137-A

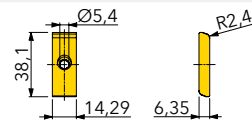

G FNC434-116T05-A

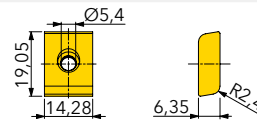

H FNC474-133-A

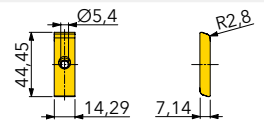

I FNC434-117T05-A

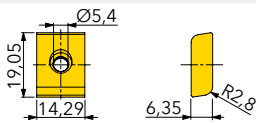

J FNC485-124-A

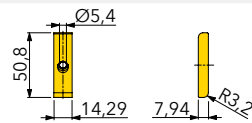

K FNC434-118T05-A

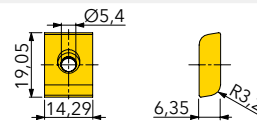

L FNC496-137-A

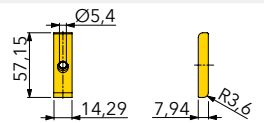

M FNC454-143T05-A

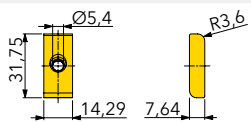

N FNC496-138

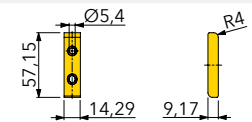

O FNC446-102T05

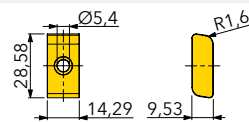

Artikel-Nr.
Designation

Ausführung
Description

Qualität
Grade

IN2040

IN2505

IN2530

FNC_ negative Geometrie / negative geometry

● = P ● = M ● = K ● = N ● = S ○ = H

SCHNITTWERTEMPFEHLUNG WÄLZFRÄSER BP II (DIN 3972)

CUTTING DATA RECOMMENDATION HOBS BP II (DIN 3972)

Modul Module	Artikel-Nr. Designation	D [mm]	ae1 [mm] Schnitt1/cut1	ae2 [mm] Schnitt2/cut2	Vc1 [m/min] Rm>1000 N/mm ²	Vc2 [m/min] Rm<1000 N/mm ²	fa [mm/WU] Z ≤50	fa [mm/WU] Z =50-100	fa [mm/WU] Z ≥100
6	77X8Z180006BDA02	180	13,5	-	160-180	180-200	1,5-2,5	2,5-4,5	4,5-6,0
	77X8Z240006BFA02	210	13,5	-	160-180	180-200	2,0-3,0	3,0-5,0	5,0-6,0
	77X8Z240006BFA02	240	13,5	-	160-180	180-200	2,5-3,5	3,5-5,0	5,0-6,0
7	77X8Z180007BDA02	180	15,75	-	160-180	180-200	1,2-2,0	2,0-3,5	3,5-5,0
	77X8Z210007BEA02	210	15,75	-	160-180	180-200	1,5-2,5	2,5-4,5	4,5-6,0
	77X8Z240007BFA02	240	15,75	-	160-180	180-200	2,0-3,0	3,0-5,0	5,0-6,0
8	77X8Z210008BEA02	210	18,00	-	140-160	160-180	1,3-2,2	2,2-4,0	4,0-6,0
	77X8Z240008BFA02	240	18,00	-	140-160	160-180	1,8-2,5	2,5-4,5	4,5-6,0
	77X8Z270008BHA02	270	18,00	-	140-160	160-180	2,0-3,5	3,5-5,0	5,0-6,0
9	77X8Z210009BEA02	210	20,25	-	140-160	160-180	1,2-1,8	1,8-3,5	3,5-5,0
	77X8Z240009BFA02	240	20,25	-	140-160	160-180	1,5-2,3	2,3-4,5	4,5-6,0
	77X8Z270009BHA02	270	20,25	-	140-160	160-180	1,8-2,8	2,8-5,0	5,0-6,0
10	77X8Z210010BEA02	210	22,50	-	140-160	160-180	1,0-1,6	1,6-3,2	3,2-5,0
	77X8Z240010BFA02	240	22,50	-	140-160	160-180	1,3-2,0	2,0-4,0	4,0-5,5
	77X8Z270010BHA02	270	22,50	-	140-160	160-180	1,6-2,5	2,5-4,5	4,5-6,0
12	77X8Z240012BFA02	240	27,00	-	120-140	140-160	0,8-1,3	1,3-2,5	2,5-4,0
	77X8Z270012BHA02	270	27,00	-	120-140	140-160	1,2-2,0	2,0-4,0	4,0-5,5
	77X8Z350012BHA02	350	27,00	-	120-140	140-160	1,8-2,8	2,8-4,5	4,5-6,0
14	77X8Z270014BHA02	270	31,50	-	120-140	140-160	1,0-1,5	1,5-3,2	3,2-4,5
	77X8Z350014BHA02	350	31,50	-	120-140	140-160	1,5-2,3	2,3-4,0	4,0-5,5
16	77X8Z270016BHA02	270	34,00	2*	120-140	140-160	0,9-1,4	1,5-2,8	2,8-4,2
	77X8Z350016BHA02	350	34,00	2*	120-140	140-160	1,4-2,2	2,2-3,8	3,8-5,2
18	77X8Z270018BHA02	270	38,00	2,5*	100-120	120-140	1,2-1,8	1,2-2,5	2,5-4,0
	77X8Z350018BHA02	350	38,00	2,5*	100-120	120-140	1,2-1,8	1,2-2,5	2,5-4,0
20	77X8Z350020BHA02	350	42,00	3*	100-120	120-140	0,7-1,1	1,1-2,2	2,2-3,6
	77X8Z450020BJA02	450	42,00	3*	100-120	120-140	1,0-1,6	1,6-3,4	3,4-4,5

*Beim 2. Schnitt können die Axialvorschübe fa wie bei Z≥100 verwendet werden.

*For the 2nd cut the axial feed rates fa can be used as for Z≥100.

Die angegebenen Werte sind eine Empfehlung, die wir natürlich den Gegebenheiten vor Ort anpassen bzw. entsprechend optimieren.
The indicated cutting data can only be a recommendation and must be adapted on location and, if necessary, optimized.

Remark: fa [mm/WU] = fa [mm/rev]

Profilausführung Wälzfräser DIN3972-BPII / Profile Design of Hobs BP II

Modul Module	S_{p0}	ρ_{aP0}	h_{aP0}	h_{p0}
6	9,43	1,2	7,50	14,7
7	11,00	1,4	8,75	17,15
8	12,57	1,6	10,00	19,6
9	14,14	1,8	11,25	22,05
10	15,70	2,0	12,50	24,5
12	18,85	2,4	15,00	29,4
14	22,00	2,8	17,50	34,3
16	25,13	3,2	20,00	39,2
18	28,27	3,6	22,50	44,1
20	31,42	4,0	25,00	49

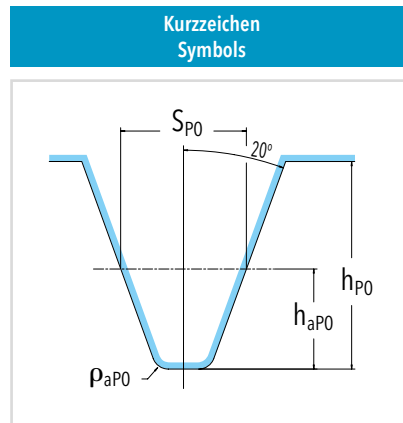

Formeln
Formulas

$$h_{aP0} = 1,250 \times m$$

$$\rho_{aP0} = 0,2 \times m$$

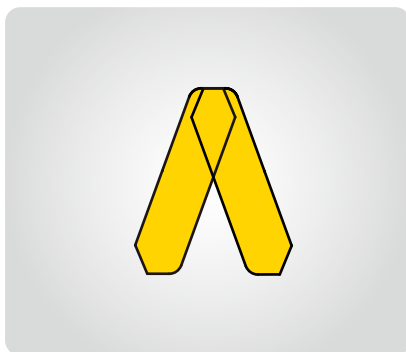
$$S_{p0} = \frac{\pi \times m}{2}$$

Ausführung Modul 6-10
Design of module 6 to 10

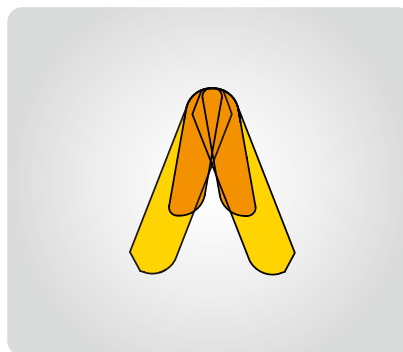

Ausführung Modul 12-20
Design of module 12 to 20

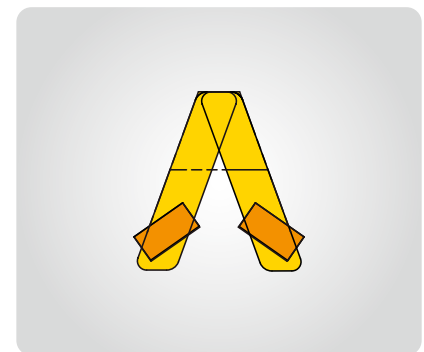

Optional auch mit Kantenbruschneiden.
Optional with inserts for semi-topping.



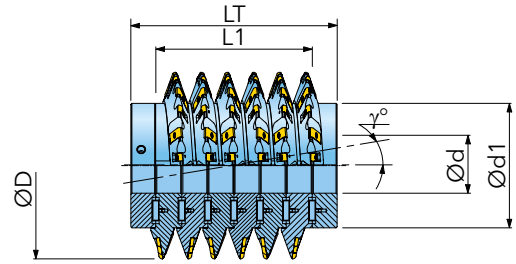

Modul Module	Artikel-Nr. Designation	D	d	Anz./no. Segm.	L1	LT	Zsegm.	Zges./total	d1	γ	Passende WSP Fitting insert
6	77X8Z180006BDA00	180	40	6	113	173	15	90	125	2,107	90x A
	77X8Z210006BEA00	210	50	6	113	173	17	102	125	1,780	102x A
	77X8Z240006BFA00	240	60	6	113	173	19	114	160	1,540	114x A
7	77X8Z180007BDA00	180	40	6	132	192	15	90	125	2,501	90x B
	77X8Z210007BEA00	210	50	6	132	192	17	102	125	2,107	102x B
	77X8Z240007BFA00	240	60	6	132	192	19	114	160	1,820	114x B
8	77X8Z210008BEA00	210	50	6	151	211	18	108	125	2,444	54x C 54x D
	77X8Z240008BFA00	240	60	6	151	211	18	108	160	2,107	54x C 54x D
	77X8Z270008BHA00	270	80	6	151	211	22	132	180	1,852	66x C 66x D
9	77X8Z210009BEA00	210	50	6	169	229	18	108	125	2,791	54x E 54x F
	77X8Z240009BFA00	240	60	6	169	229	18	108	160	2,401	54x E 54x F
	77X8Z270009BHA00	270	80	6	169	229	22	132	180	2,107	66x E 66x F
10	77X8Z210010BEA00	210	50	6	189	249	18	108	125	3,150	54x G 54x H
	77X8Z240010BFA00	240	60	6	189	249	18	108	160	2,704	54x G 54x H
	77X8Z270010BHA00	270	80	6	189	249	22	132	180	2,368	66x G 66x H
12	77X8Z240012BFA00	240	60	6	226	298	18	108	140	3,339	54x I 54x J
	77X8Z270012BHA00	270	80	6	226	298	22	132	180	2,910	66x I 66x J
	77X8Z350012BHA00	350	80	6	226	298	26	156	240	2,174	78x I 78x J
14	77X8Z270014BHA00	270	80	6	264	336	22	132	180	3,478	66x K 66x L
	77X8Z350014BHA00	350	80	6	264	336	26	156	240	2,582	78x K 78x L
16	77X8Z270016BHA00	270	80	6	302	375	22	132	160	4,074	66x M 66x N
	77X8Z350016BHA00	350	80	6	302	375	26	156	220	3,005	78x M 78x N
18	77X8Z270018BHA00	270	80	5	283	355	22	110	145	4,702	55x O 55x P
	77X8Z350018BHA00	350	80	5	283	355	26	130	220	3,444	65x O 65x P
20	77X8Z350020BHA00	350	80	5	314	386	26	130	220	3,901	65x Q 65x R
	77X8Z450020BJA00	450	100	5	314	386	34	170	270	2,910	85x Q 85x R

Die Wälzfräser werden im Allgemeinen eingängig rechtssteigend in der Güteklasse B nach DIN 3968 gefertigt. Wälzfräser linkssteigend auf Anfrage.
Hobs are generally produced in a single thread right-hand design in class B according to DIN 3968. Hobs in left-hand design on request.

ZUBEHÖR / SPARE PARTS

Senkschraube / Insert screw

SM40-090-00

für Platten / for inserts:

A B C D E F
H J



Senkschraube / Insert screw

SM50-120-10

für Platten / for inserts:

G I L N



Senkschraube / Insert screw

SM50-160-10

für Platten / for inserts:

K M O P Q R



WENDESCHNEIDPLATTEN / INSERTS

A FNC343-115-A

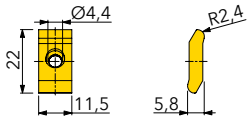

B FNC343-116-A

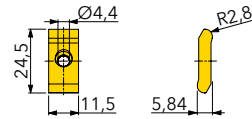

C FNC343-102-A

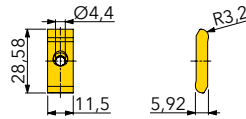

D FNC333-124T05-A

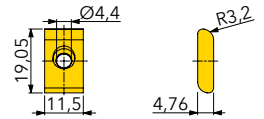

E FNC343-104-A

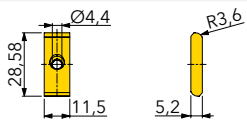

F FNC333-125T05-A

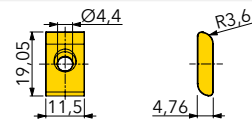

G FNC454-136-A

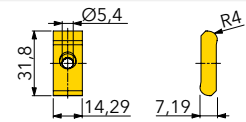

H FNC333-130T05-A

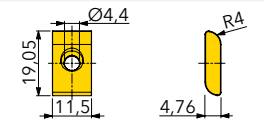

I FNC464-119-A

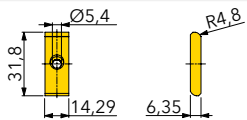

J FNC333-142T05-A

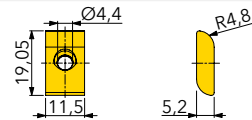

K FNC474-118-A

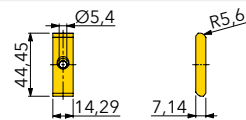

L FNC434-114T05-A

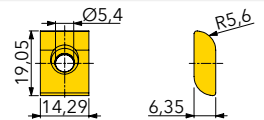

M FNC485-108-A

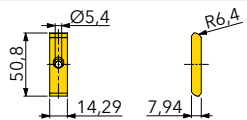

N FNC434-115T05-A

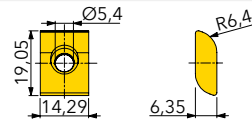

O FNC496-131-A

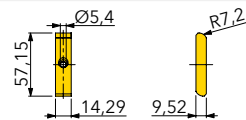

P FNC454-142T05-A

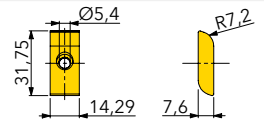

Q FNC4106-110

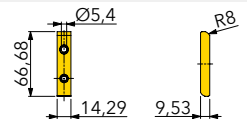

R LNA446-145T05

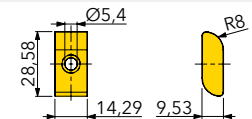

Artikel-Nr.
Designation

Ausführung
Description

Qualität
Grade

IN2040

IN2505

IN2530

FNC_ negative Geometrie / negative geometry

● = P ● = M ● = K ● = N ● = S ○ = H

SCHNITTWERTEMPFEHLUNG SCHRUPPWÄLZFRÄSER MIT PROTUBERANZ

CUTTING DATA RECOMMENDATION ROUGHING HOBS WITH PROTUBERANCE

Modul Module	Artikel-Nr. Designation	D [mm]	ae1 [mm] Schnitt1/cut1	ae2 [mm] Schnitt2/cut2	Vc1 [m/min] Rm>1000 N/mm ²	Vc2 [m/min] Rm<1000 N/mm ²	fa [mm/WU] Z ≤50	fa [mm/WU] Z =50-100	fa [mm/WU] Z >=100
6	77X8Z180006BDA00	180	14,7	-	140-160	160-180	1,2-2,3	2,3-4,0	4,0-5,5
	77X8Z210006BEA00	210	14,7	-	140-160	160-180	1,8-2,7	2,7-4,6	4,6-6,0
	77X8Z240006BFA00	240	14,7	-	140-160	160-180	2,2-3,2	3,2-4,8	4,8-6,0
7	77X8Z180007BDA00	180	17,2	-	140-160	160-180	1,0-1,8	1,8-3,2	3,2-5,0
	77X8Z210007BEA00	210	17,2	-	140-160	160-180	1,3-2,2	2,2-4,2	4,2-6,0
	77X8Z240007BFA00	240	17,2	-	140-160	160-180	1,8-2,8	2,8-4,4	4,4-6,0
8	77X8Z210008BEA00	210	19,6	-	120-140	140-160	1,2-2,0	2,0-3,8	3,8-5,0
	77X8Z240008BFA00	240	19,6	-	120-140	140-160	1,5-2,3	2,3-4,2	4,2-5,5
	77X8Z270008BHA00	270	19,6	-	120-140	140-160	1,8-3,2	3,2-4,6	4,6-6,0
9	77X8Z210009DEA00	210	22,0	-	120-140	140-160	1,0-1,6	1,6-3,2	3,2-5,0
	77X8Z240009BFA00	240	22,0	-	120-140	140-160	1,3-2,0	2,0-4,0	4,0-5,5
	77X8Z270009BHA00	270	22,0	-	120-140	140-160	1,6-2,5	2,5-4,5	4,5-6,0
10	77X8Z210010BEA00	210	24,5	-	120-140	140-160	0,9-1,5	1,5-3,0	3,0-5,0
	77X8Z240010BFA00	240	24,5	-	120-140	140-160	1,2-1,8	1,8-3,8	3,8-5,5
	77X8Z270010BHA00	270	24,5	-	120-140	140-160	1,5-2,4	2,4-4,3	4,3-6,0
12	77X8Z240012BFA00	240	29,4	-	100-120	120-140	0,6-1,1	1,1-2,0	2,0-3,5
	77X8Z270012BHA00	270	29,4	-	100-120	120-140	1,0-1,6	1,6-3,5	3,5-4,5
	77X8Z350012BHA00	350	29,4	-	100-120	120-140	1,4-2,4	2,4-4,0	4,0-5,5
14	77X8Z270014BHA00	270	34,3	-	100-120	120-140	0,8-1,3	1,3-3,0	3,0-4,5
	77X8Z350014BHA00	350	34,3	-	100-120	120-140	1,2-2,0	2,0-3,8	3,8-5,5
16	77X8Z270016BHA00	270	37,2	2*	100-120	120-140	0,8-1,2	1,2-2,5	2,5-4,0
	77X8Z350016BHA00	350	37,2	2*	100-120	120-140	1,2-1,8	1,8-3,5	3,5-5,0
18	77X8Z270018BHA00	270	41,6	2,5*	80-100	100-120	0,7-1,1	1,1-2,2	2,2-3,5
	77X8Z350018BHA00	350	41,6	2,5*	80-100	100-120	1,0-1,6	1,6-3,4	3,4-5,0
20	77X8Z350020BHA00	350	46,0	3*	80-100	100-120	0,6-1,0	1,0-2,0	2,0-3,5
	77X8Z450020BJA00	450	46,0	3*	80-100	100-120	0,9-1,5	1,5-3,2	3,2-5,0

*Beim 2. Schnitt können die Axialvorschübe fa wie bei Z>=100 verwendet werden.

*For the 2nd cut the axial feed rates fa can be used as for Z>=100.

Die angegebenen Werte sind eine Empfehlung, die wir natürlich den Gegebenheiten vor Ort anpassen bzw. entsprechend optimieren.
The indicated cutting data can only be a recommendation and must be adapted on location and, if necessary, optimized.

Remark: fa [mm/WU] = fa [mm/rev]

Profilausführung Walzfräser mit Protuberanz / Profile Design of Hob with Protuberance

Modul Module	S_{p0}	P_{rP0}^*	ρ_{aP0}	h_{aP0}	h_{p0}
6	9,43	-	2,4	8,85	16
7	11,00	-	2,8	10,30	19
8	12,57	-	3,2	11,73	21
9	14,14	-	3,6	13,17	24
10	15,70	-	4,0	14,61	26
12	18,85	-	4,8	17,52	32
14	22,00	-	5,6	20,45	37
16	25,13	-	6,4	23,37	42
18	28,27	-	7,2	26,30	47
20	31,42	-	8,0	29,23	52

*Auf Anfrage / *On request

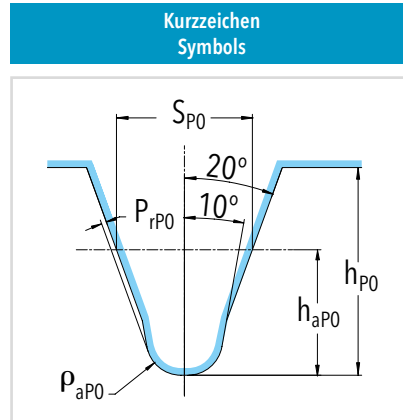

**Formeln
Formulas**

$$S_{p0} = \frac{\pi \cdot m}{2}$$

$$h_{aP0} = 1,4 \cdot m + \frac{q}{\sin 20^\circ}$$

$$\rho_{aP0} = 0,4 \cdot m$$

**q = Aufmaß zum Schleifen
q = stock for grinding**

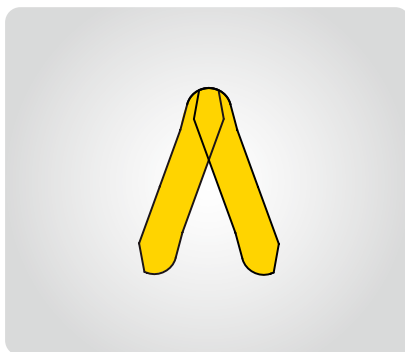

Ausführung Modul 6-7
Design of module 6 to 7

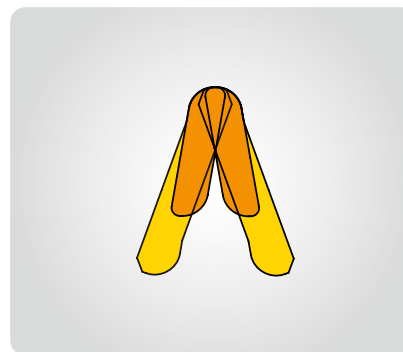

Ausführung Modul 8-10
Design of module 8 to 10

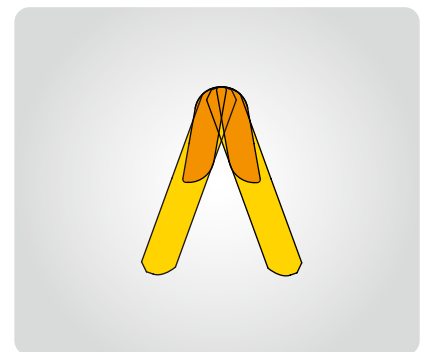

Ausführung >= Modul 12
Design of module 12 and over



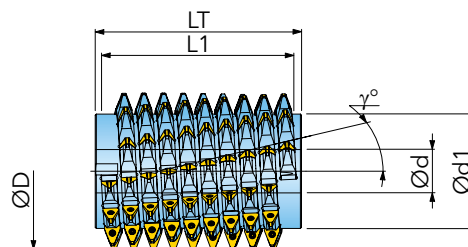
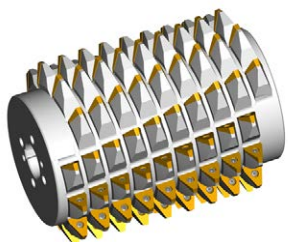

Modul Module	Artikel-Nr. Designation	D	d	Anz.Windungen No. of windings	L1	LT	Z _{eff.}	Z _{ges./Z_{total}}	d1	γ	Passende WSP Fitting insert
4	75X8Z090004BCA02	90	32	9	113	136	10	92	60	2,866	A
	75X8Z120004BDA02	120	40	9	113	136	13	119	90	2,084	A
	75X8Z150004BEA02	150	50	9	113	136	16	146	120	1,637	A
5	75X8Z090005BCA02	90	32	9	141	167	10	92	55	3,699	B
	75X8Z120005BDA02	120	40	9	141	167	13	119	85	2,666	B
	75X8Z150005BEA02	150	50	9	141	167	16	146	115	2,084	B
6	75X8Z120006BDA02	120	40	6	113	140	10	61	72	3,276	C
	75X8Z150006BEA02	150	50	6	113	140	13	79	102	2,547	C
	75X8Z180006BFA02	180	60	6	113	140	16	97	132	2,084	C
7	75X8Z150007BEA02	150	50	6	132	155	8	50	98	3,028	D
	75X8Z180007BFA02	180	60	6	132	155	10	62	128	2,469	D
	75X8Z210007BFA02	210	60	6	132	155	12	74	158	2,084	D
8	75X8Z180008BFA02	180	60	6	151	175	10	62	124	2,866	E
	75X8Z210008BFA02	210	60	6	151	175	12	74	154	2,413	E
	75X8Z240008BHA02	240	80	6	151	175	14	86	184	2,084	E

Wälzfräser werden im Allgemeinen eingängig rechtssteigend in der Güteklasse B nach DIN 3968 gefertigt. Wälzfräser linkssteigend, mehrgängig und in Güteklasse A auf Anfrage.
Hobs are generally produced in a single thread right-hand design in class B according to DIN 3968. Hobs in left-hand design, multiple thread and in class A on request.

ZUBEHÖR / SPARE PARTS

Senkschraube / Insert screw

SM30-082-20

für Platten / for inserts:

A B C



Senkschraube / Insert screw

SM50-140-10

für Platte / for inserts:

D E



VOLLPROFILPLATTEN / FULL PROFILE INSERTS

A ZPDW040508

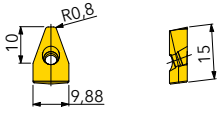
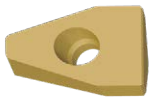

B ZPDW050610

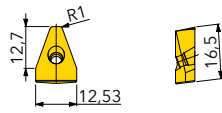
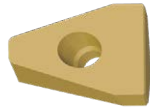

C ZPDW060612

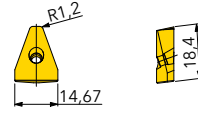

D ZPDW070814

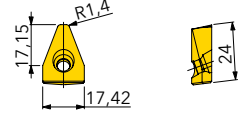
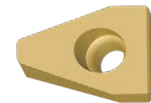

E ZPDW080816

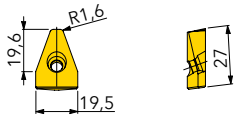
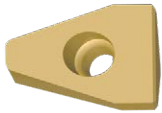

Artikel-Nr.
Designation

Ausführung
Description

Qualität
Grade

IN2505

IN4005

ZPDW_

positive Geometrie / positive geometry



● = P ● = M ● = K ● = N ● = S ○ = H

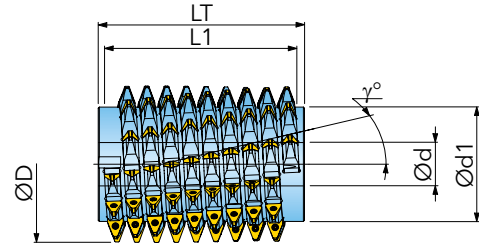
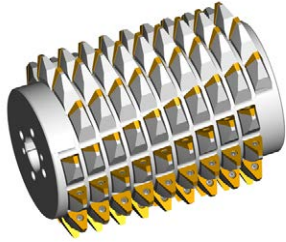

Modul Module	Artikel-Nr. Designation	D	d	Anz.Windungen No. of windings	L1	LT	Z _{eff.}	Z _{ges./Z_{total}}	d1	γ	Passende WSP Fitting insert
4	75X8Z090004BCA00	90	32	9	113	136	10	92	60	2,866	A
	75X8Z120004BDA00	120	40	9	113	136	13	119	90	2,084	A
	75X8Z150004BEA00	150	50	9	113	136	16	146	120	1,637	A
5	75X8Z090005BCA00	90	32	9	141	167	10	92	55	3,699	B
	75X8Z120005BDA00	120	40	9	141	167	13	119	85	2,666	B
	75X8Z150005BEA00	150	50	9	141	167	16	146	115	2,084	B
6	75X8Z120006BDA00	120	40	6	113	140	10	61	72	3,276	C
	75X8Z150006BEA00	150	50	6	113	140	13	79	102	2,547	C
	75X8Z180006BFA00	180	60	6	113	140	16	97	132	2,084	C
7	75X8Z150007BEA00	150	50	6	132	155	8	50	98	3,028	D
	75X8Z180007BFA00	180	60	6	132	155	10	62	128	2,469	D
	75X8Z210007BFA00	210	60	6	132	155	12	74	158	2,084	D
8	75X8Z180008BFA00	180	60	6	151	175	10	62	124	2,866	E
	75X8Z210008BFA00	210	60	6	151	175	12	74	154	2,413	E
	75X8Z240008BHA00	240	80	6	151	175	14	86	184	2,084	E

Wälzfräser werden im Allgemeinen eingängig rechtssteigend in der Güteklasse B nach DIN 3968 gefertigt. Wälzfräser linkssteigend, mehrgängig und in Güteklasse A auf Anfrage.
Hobs are generally produced in a single thread right-hand design in class B according to DIN 3968. Hobs in left-hand design, multiple thread and in class A on request.

ZUBEHÖR/SPARE PARTS

Senkschraube / Insert screw

SM30-082-20

für Platten / for inserts:

A B C



Senkschraube / Insert screw

SM50-140-10

für Platte / for inserts:

D E



VOLLPROFILPLATTEN / FULL PROFILE INSERTS

A ZPDW040516

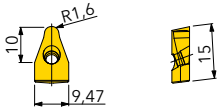

B ZPDW050620

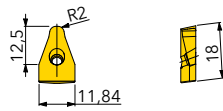
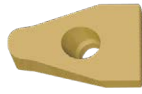

C ZPDW060624

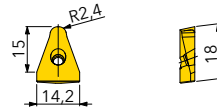
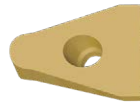

D ZPDW070828

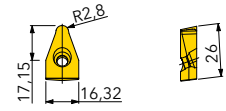
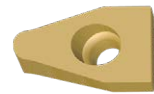

E ZPDW080832

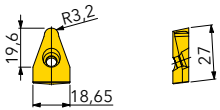
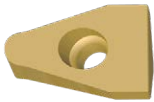

Artikel-Nr.
Designation

Ausführung
Description

Qualität
Grade

IN2505

IN4005

ZPDW_

positive Geometrie / positive geometry

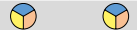

● = P ● = M ● = K ● = N ● = S ○ = H

Fertigfräsen mit Wälzfräser

Stirnrad M7, z = 41, Werkstoff: 16MnCr5

Finishing with hob

Gear wheel M7, z = 41, material: 16MnCr5

D = 210 mm

n1 = 334 min⁻¹ [rpm] fa1 = 2,5 mm/WU [mm WR] ae1 = 45,5 mm

n2 = 425 min⁻¹ [rpm] fa2 = 6 mm/WU [mm WR] ae2 = 0,75 mm



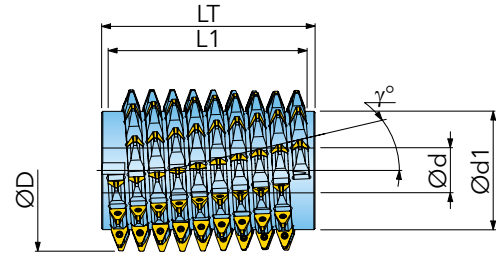
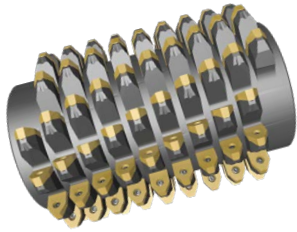

Modul Module	Artikel-Nr. Designation	D	d	Anz.Windungen No. of windings	L1	LT	Z _{eff.}	Z _{ges./} Z _{total}	d1	γ	Passende WSP Fitting insert
4	75X8Z090004BCA54	90	32	9	113	136	11	100	63	2,690	A
	75X8Z120004BDA54	120	40	9	113	136	14	127	93	1,990	A
	75X8Z150004BEA54	150	50	9	113	136	17	154	123	1,578	A
5	75X8Z090005BCA54	90	32	9	141	168	10	92	57	3,412	B
	75X8Z120005BDA54	120	40	9	141	168	13	119	87	2,514	B
	75X8Z150005BEA54	150	50	9	141	168	16	146	117	1,990	B
6	75X8Z120006BDA54	120	40	6	113	140	12	74	89	3,049	C
	75X8Z150006BEA54	150	50	6	113	140	15	92	119	2,408	C
	75X8Z180006BFA54	180	60	6	113	140	18	110	149	1,990	C
7	75X8Z150007BEA54	150	50	6	132	155	11	68	112	2,834	D
	75X8Z180007BFA54	180	60	6	132	155	13	80	142	2,338	D
	75X8Z210007BFA54	210	60	6	132	155	15	92	172	1,990	D
8	75X8Z180008BFA54	180	60	6	151	175	13	80	138	2,691	E
	75X8Z210008BFA54	210	60	6	151	175	15	92	168	2,288	E
	75X8Z240008BHA54	240	80	6	151	175	17	104	198	1,990	E

Wälzfräser werden im Allgemeinen eingängig rechtssteigend in der Güteklasse B nach DIN 3968 gefertigt. Wälzfräser linkssteigend, mehrgängig und in Güteklasse A auf Anfrage.
Hobs are generally produced in a single thread right-hand design in class B according to DIN 3968. Hobs in left-hand design, multiple thread and in class A on request.

ZUBEHÖR / SPARE PARTS

Senkschraube / Insert screw

SM30-082-20

für Platten / for inserts:

A B C



Senkschraube / Insert screw

SM50-140-10

für Platte / for inserts:

D E



VOLLPROFILPLATTEN / FULL PROFILE INSERTS

A ZPDW040506

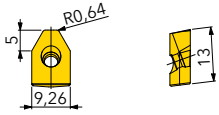
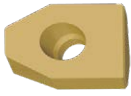

B ZPDW050608

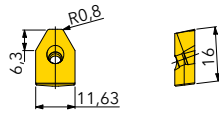

C ZPDW060609

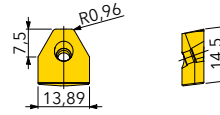
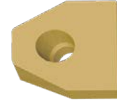

D ZPDW070811

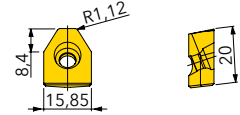
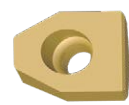

E ZPDW080813

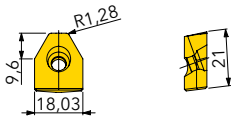

Artikel-Nr.
Designation

Ausführung
Description

Qualität
Grade

IN2505

IN4005

ZPDW_

positive Geometrie / positive geometry



● = P ● = M ● = K ● = N ● = S ○ = H

Gegenüberstellung Werkzeug-Güteklasse / Profil-Gesamtabweichung der Verzahnung
Comparison Tool Class / Total Profile Deviation of Gear

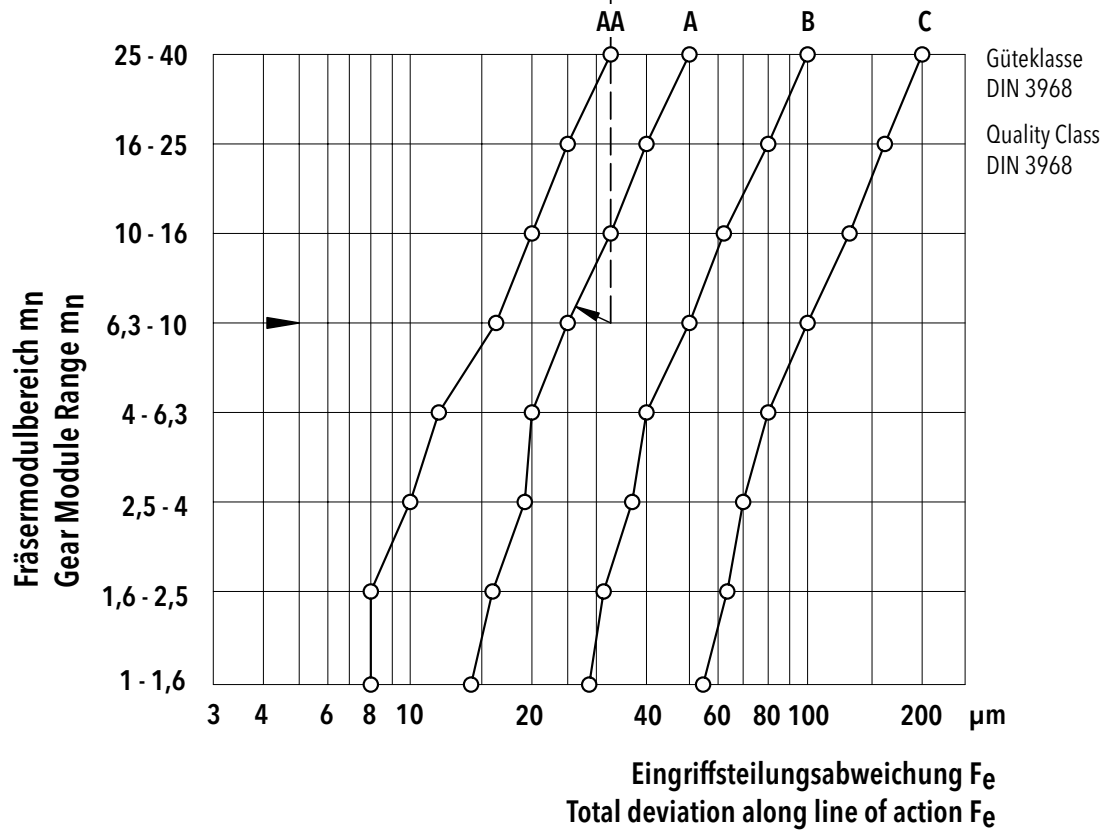
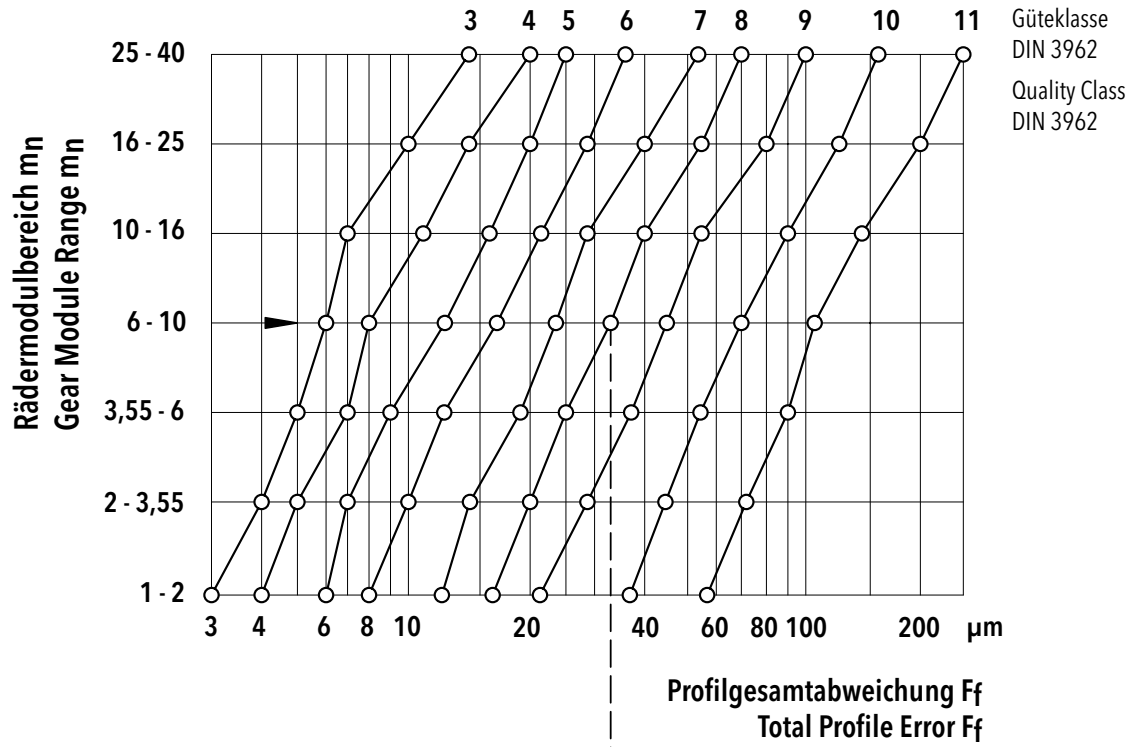

Toleranzen eingängiger Wälzfräser für Stirnräder mit Evolventenverzahnung
Accuracy Requirements for Single Thread Hobs

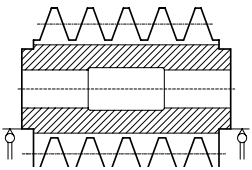
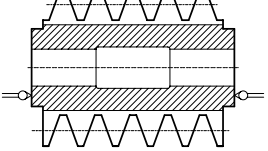
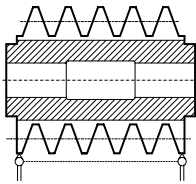
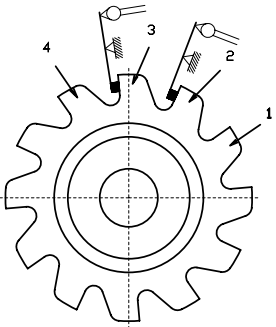
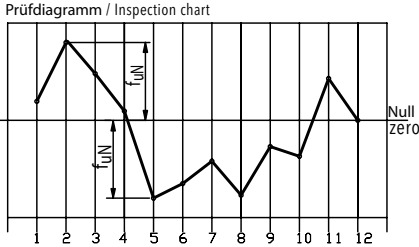
Nr. No.	Zu messende Größe Measured dimension	Kurz- zeichen short descript.	Güte- klasse quality class	Toleranzen in μm ($1 \mu\text{m} = 0,001 \text{ mm}$) bei Modul Tolerance in μm ($1 \mu\text{m} = 0,001 \text{ mm}$) at module								
				>0,63-1	>1-1,6	>1,6-2,5	>2,5-4	>4-6,3	>6,3-10	>10-16	>16-25	>25-40
4	Rundlaufabweichung an den beiden Prüfbunden Radial runout of hub diameter 	f _{rp}	AA	5	5	5	5	5	5	6	6	8
			A	5	5	5	6	8	10	12	16	20
			B	6	6	6	8	10	12	16	20	25
			C	10	10	10	12	16	20	25	32	40
5	Planlaufabweichung an den Spannflächen Axial runout of hub face 	f _{pa}	AA	3	3	3	3	3	4	5	5	6
			A	3	3	3	5	5	8	8	10	10
			B	4	4	4	6	6	10	10	12	12
			C	6	6	6	10	10	16	16	20	20
D	10	10	10	16	16	25	25	32	32			
6	Rundlaufabweichung am Zahnkopf Radial runout of tips of teeth 	f _{rk}	AA	10	10	12	16	20	25	32	40	50
			A	12	16	20	25	32	40	50	63	80
			B	25	32	40	50	63	80	100	125	160
			C	50	63	80	100	125	160	200	250	315
D	100	125	160	200	250	315	400	500	630			
8	Einzelteilung der Spannuten Adjacent spacing of the cutting face of gashes  	f _{tN}	AA	± 10	± 10	± 12	± 16	± 20	± 25	± 32	± 40	± 50
			A	± 12	± 16	± 20	± 25	± 32	± 40	± 50	± 63	± 80
			B	± 25	± 32	± 40	± 50	± 63	± 80	± 100	± 125	± 160
			C	± 50	± 63	± 80	± 100	± 125	± 160	± 200	± 250	± 315
D	± 100	± 125	± 160	± 200	± 250	± 315	± 400	± 500	± 630			

Toleranzen eingängiger Wälzfräser für Stirnräder mit Evolventenverzahnung
Accuracy Requirements for Single Thread Hobs

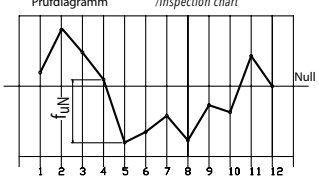
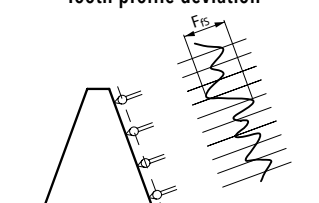
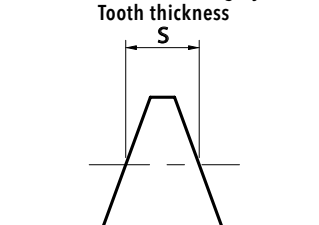
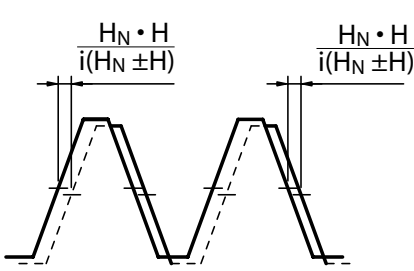
Nr. No.	Zu messende Größe Measured dimension	Kurzzeichen short descript.	Güteklasse quality class	Toleranzen in µm (1 µm=0,001 mm) bei Modul Tolerance in µm (1 µm = 0,001 mm) at module								
				>0,63-1	>1-1,6	>1,6-2,5	>2,5-4	>4-6,3	>6,3-10	>10-16	>16-25	>25-40
9	Teilungssprung der Spannuten gemessen in halber Zahnhöhe Pitch error of the cutting face of gashes Prüfdiagramm / Inspection chart 	f _{uN}	AA	10	10	12	16	20	25	32	40	50
			A	12	16	20	25	32	40	50	63	80
			B	25	32	40	50	63	80	100	125	160
			C	50	63	80	100	125	160	200	250	345
			D	100	125	160	200	250	315	400	500	630
12	Formabweichung der Schneidkante Tooth profile deviation 	F _{fs}	AA	6	6	6	8	10	12	14	18	22
			A	10	11	12	14	16	20	25	32	40
			B	20	22	25	28	32	40	50	63	80
			C	40	45	50	56	63	80	100	125	160
			D	60	70	80	90	100	125	160	200	250
13	Zahndicke auf dem Bezugszylinder Tooth thickness 	f _s	AA	-16	-16	-16	-20	-25	-32	-40	-50	-63
			A	-25	-28	-32	-36	-40	-50	-63	-80	-100
			B	-50	-56	-63	-71	-80	-100	-125	-160	-200
			C	-100	-112	-125	-140	-160	-200	-250	-320	-400
			D	-100	-112	-125	-140	-160	-200	-250	-320	-400
14	Fräsersteigungshöhe von Schneidkante zu Schneidkante in Gangrichtung Lead deviation on adjacent teeth 	f _{HF}	AA	± 4	± 4	± 4	± 5	± 6	± 8	± 10	± 12	± 16
			A	± 6	± 7	± 8	± 9	± 10	± 12	± 16	± 20	± 25
			B	± 12	± 14	± 16	± 18	± 20	± 25	± 32	± 40	± 50
			C	± 25	± 28	± 32	± 36	± 40	± 50	± 63	± 80	± 100
			D	± 50	± 56	± 63	± 71	± 80	± 100	± 125	± 160	± 200

Toleranzen eingängiger Wälzfräser für Stirnräder mit Evolventenverzahnung
Accuracy Requirements for Single Thread Hobs

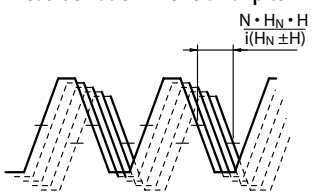
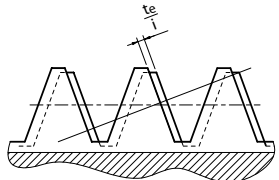
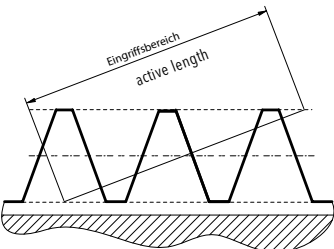
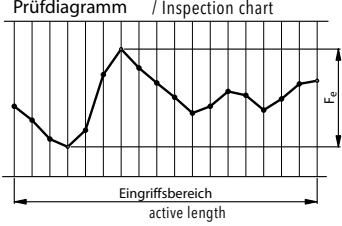
Nr. No.	Zu messende Größe Measured dimension	Kurz- zeichen short descript.	Güte- klasse quality class	Toleranzen in μm ($1 \mu\text{m} = 0,001 \text{ mm}$) bei Modul Tolerance in μm ($1 \mu\text{m} = 0,001 \text{ mm}$) at module								
				>0,63-1	>1-1,6	>1,6-2,5	>2,5-4	>4-6,3	>6,3-10	>10-16	>16-25	>25-40
15	Fräsersteigungshöhe in Gangrichtung zwischen beliebigen Schneidkanten einer Windung Lead deviation in one axial pitch 	F _{HF}	AA	6	6	6	8	10	12	14	18	22
			A	10	11	12	14	16	20	25	32	40
			B	20	22	25	28	32	40	50	63	80
			C	40	45	50	56	63	80	100	125	160
			D	80	90	100	112	125	160	200	250	320
16	Eingriffsteilungsabschnitt gemessen von Schneidkante zu Schneidkante Adjacent deviation along line of action 	f _e	AA	± 4	± 4	± 4	± 5	± 6	± 8	± 10	± 12	± 16
			A	± 6	± 7	± 8	± 9	± 10	± 12	± 16	± 20	± 25
			B	± 12	± 14	± 16	± 18	± 20	± 25	± 32	± 40	± 50
			C	± 25	± 28	± 32	± 36	± 40	± 50	± 63	± 80	± 100
17	Eingriffsteilung innerhalb eines Eingriffsbereiches Total deviation along line of action 	F _e	AA	8	8	8	10	12	16	20	25	32
			A	12	14	16	18	20	25	32	40	50
			B	25	28	32	36	40	50	63	80	100
			C	50	56	63	71	80	100	125	160	200
Prüfdiagramm / Inspection chart 												

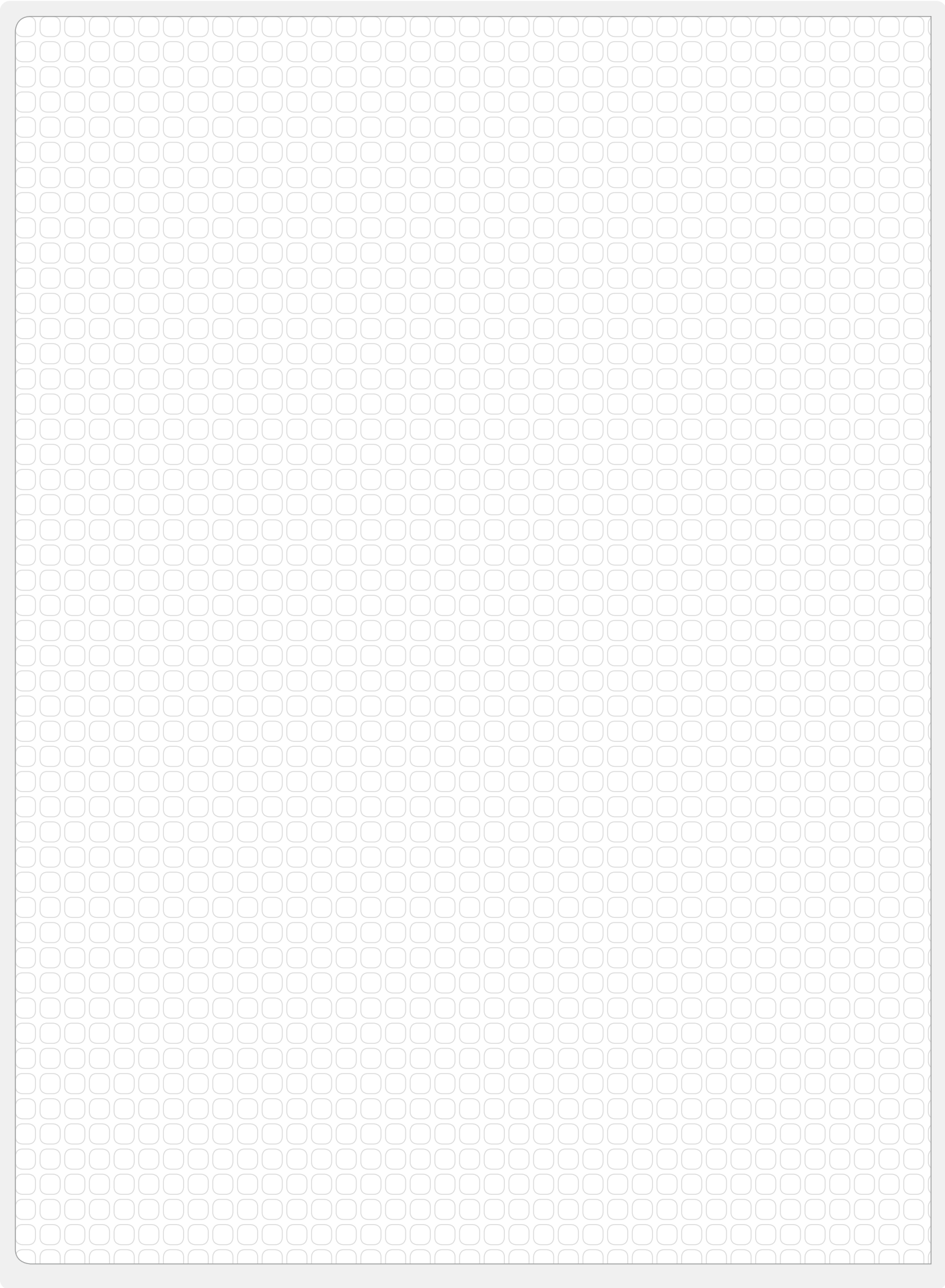

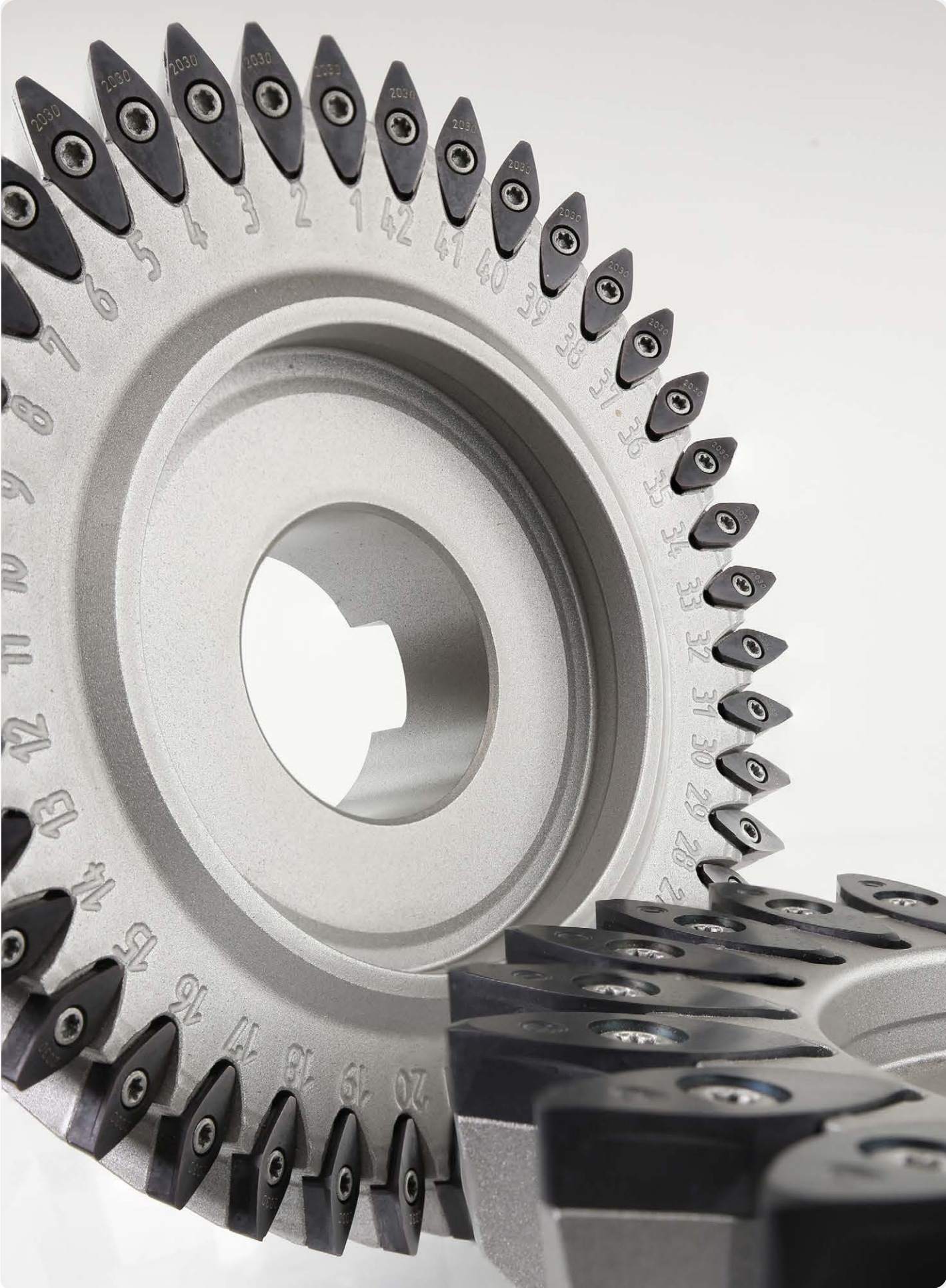

Allgemeine Beschreibung / General Description

Wälzstoßen ist ein, seit Mitte der zwanziger Jahre des letzten Jahrhunderts, etabliertes Bearbeitungsverfahren zur Erzeugung von Verzahnungen. Das Wälzstoßverfahren ist eines der universellsten Bearbeitungsverfahren zur Herstellung von Zahnradern. Es ist für die Herstellung von Verzahnungen bei bestimmten Werkstückgeometrien, wie Innenverzahnungen und an Schultern, aber auch für Sonderanwendungen, wie unrunder Konturen, unverzichtbar. Trotz der gegenüber anderen Verzahnverfahren, wie Wälzfräsen eingeschränkten Produktivität, gibt es im Bereich der Verfahrenstechnik, bei Maschinen, Werkzeugen und in der Technologie neuere Entwicklungen, welche die Wirtschaftlichkeit und Qualität des Verfahrens deutlich verbessern.

Bis heute hat sich allerdings an den verwendeten Wälzwerkzeugen, den Stoßrädern, wenig bis nichts geändert, abgesehen von der Genauigkeit und den verwendeten Werkstoffen. Eingesetzt werden nach wie vor überwiegend Stoßräder aus HSS und in kleinem Umfang Stoßräder aus Vollhartmetall.

Zum Einsatz kommen Scheibenschneidräder (DIN 1825), Glockenschneidräder (DIN 1826) und Schaftschneidräder (DIN 1828), wobei die Scheibenschneidräder überwiegen. Neu an diesem Werkzeugkonzept ist die erstmalige und momentan einzigartige Verwendung von Wendepplatten für diese Bearbeitung. Ingersoll ist zurzeit noch der einzige Anbieter solcher Werkzeuge.

In erster Linie wurden diese Werkzeuge für die Schruppbearbeitung, d.h. das Vorverzahn zum Fertigstoßen, bzw. Fertigschleifen konzipiert. Zahnräder mit geringeren Ansprüchen an die Qualität können in Grenzen fertiggestoßen werden.

Generell wird überall dort wälzgestoßen, wo ein Einzelteil- oder Wälzfräsen nicht möglich ist. Gerad- und schrägverzahnte Innen- und Außenstirnräder können im Wälzstoßverfahren hergestellt werden. Wirtschaftlich gesehen kann man das Wälzstoßen, nach Wälz- und Einzelteilfräsen, auf Platz drei setzen.

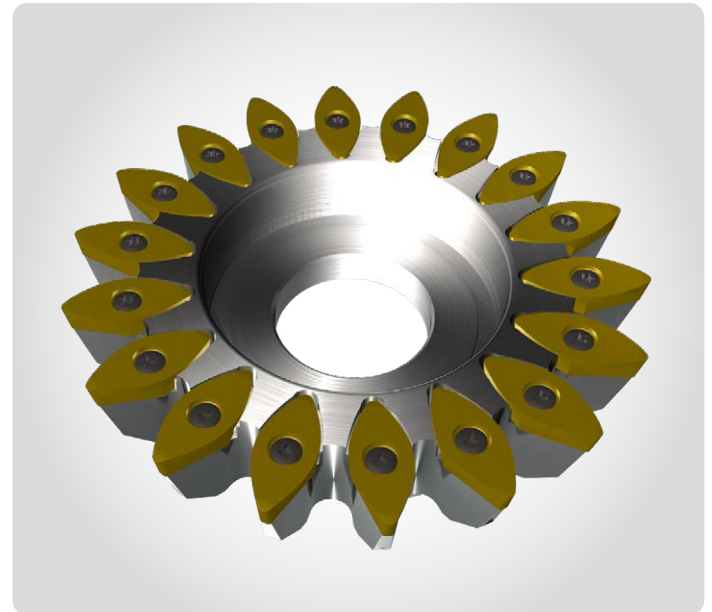
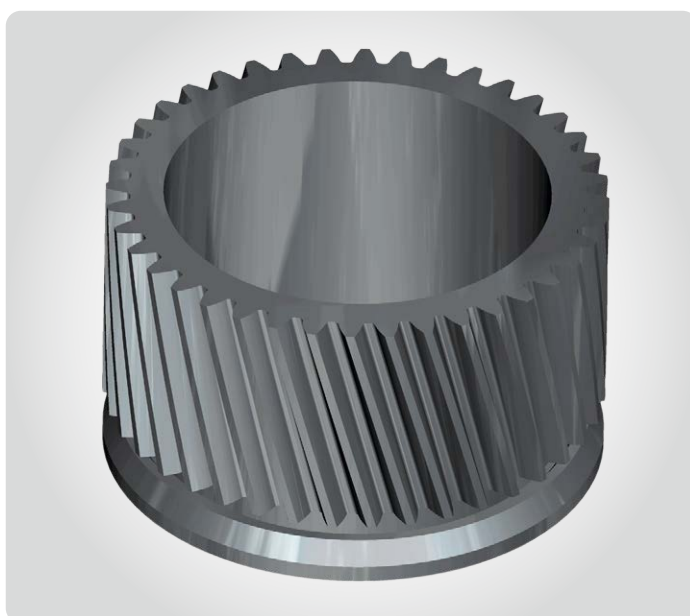

**Wendepplattenstoßrad 74X8D /
Indexable Insert Gear Shaper 74X8D**

Gear shaping has been an established machining process for generating gears since the mid-twenties of the last century. Gear shaping is one of the most widely used machining methods for producing gearwheels. It is indispensable for the production of gearing on certain workpiece geometries and on shoulders, but also for special applications, such as non-round contours. Despite the limited productivity compared to other gearing methods such as hobbing, new developments have been made in the process engineering, machinery, tools and technology areas, which considerably improve the economic efficiency and quality of the process.

To date, however, very little, if anything, has changed on the used gear-shaping tools, except for the accuracy and the materials. Gear shapers made of HSS, and to a lesser degree, solid carbide gear shapers are still used. Disk-type shapers (DIN 1825), bell-type shapers (DIN 1826) and shank-type shapers (DIN 1828) are used, whereby the disk-type shapers are used most often. New to the tool concept is the use and presently unique application of indexable inserts for this machining process. Ingersoll is presently still the only supplier of such tools.

These tools were primarily designed for roughing, i.e. gashing ready for finish-shaping or finish-grinding. Gearwheels with low quality requirements can be finish-shaped, within limits.

The gear shaping method is generally used whenever index milling or hobbing is not possible. Straight- and helical-toothed, internal and external spur gears can be produced using the gear-shaping method. From an economic point of view, gear-shaping comes in third, after hobbing and index milling.

Werkstückbedingt ist es jedoch das universellste aller Verfahren, da neben „normalen“ Außen- und Innenverzahnungen auch solche bearbeitet werden können, die mit den zuvor genannten Verfahren geometriebedingt nicht herstellbar sind, die da wären:

- Außen- und Innenverzahnungen mit Schultern
- Außen- und Innenpfeilverzahnungen
- Verzahnungen mit Anlaufflächen
- Bauteilbedingte Störkonturen
- Generell Verzahnungen, die ein Überlaufen eines Scheiben- bzw. Wälzfräasers nicht zulassen, sogenannte Kollisionsverzahnungen.

Letztendlich kann mit dem Wälzstoßverfahren jede Verzahnung hergestellt werden, die auch im Wälzfräs- und Einzelteilfräsverfahren hergestellt werden kann, umgekehrt aber nur in Grenzen.

Die neuen Stoßwerkzeuge sind generell für die Schruppbearbeitung als Vorbearbeitung zum Fertigstoßen bzw. Fertigschleifen konzipiert. Untergeordnete Radqualitäten, bis maximal Q8, sind realisiert worden, können aber nicht grundsätzlich garantiert werden, da Werkstückqualitäten keine Rückschlüsse auf Werkzeugqualitäten zulassen. Momentan wird am Werkzeug angenähert eine Qualität gemäß Güteklasse B nach DIN 1829 erreicht.

Standardmäßig werden Profile gemäß DIN 3972 nach Bezugsprofil II und Bezugsprofil III hergestellt.

From an economical point of view, however, it is the most universal of all methods, as in addition to 'normal' external and internal gearing, it can also be used to generate other gears, which, due to their geometry, cannot be produced with the aforementioned methods, such as:

- *External and internal gearing with shoulders*
- *External and internal herringbone gearing*
- *Gearing with thrust surfaces*
- *Component-related interference contours*
- *General gearing that does not permit an overrun of a side and face mill or a hob, so called collision gearing.*

When all is said and done, the gear shaping method can be used to generate every type of gear that can be generated using the hobbing or index milling method, but conversely, this is only possible to a limited degree.

The new gear shapers are generally designed for roughing, i.e. gashing in preparation for finish-shaping or finish-grinding. Lower gear qualities of up to max Q8 have been achieved, but cannot be generally guaranteed, as workpiece qualities do not allow any conclusions to be drawn about tool qualities. At present, the tools approximately correspond to grade B according to DIN 1829.

Profiles are standardly produced to reference profile II and reference profile III standards, as defined in DIN 3972.

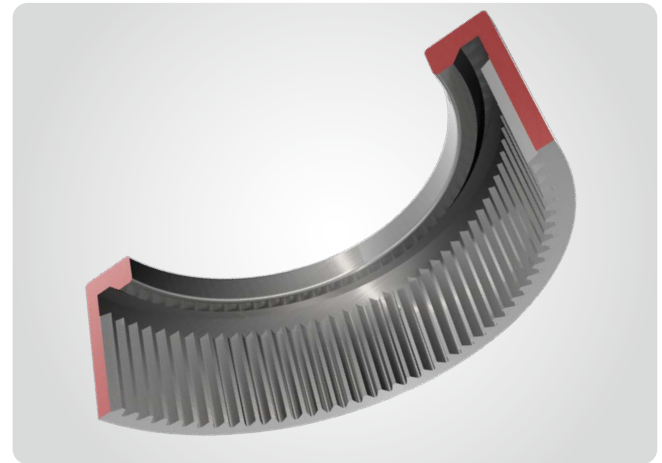

Innenverzahnung mit Schulter
Internal gearing with shoulder

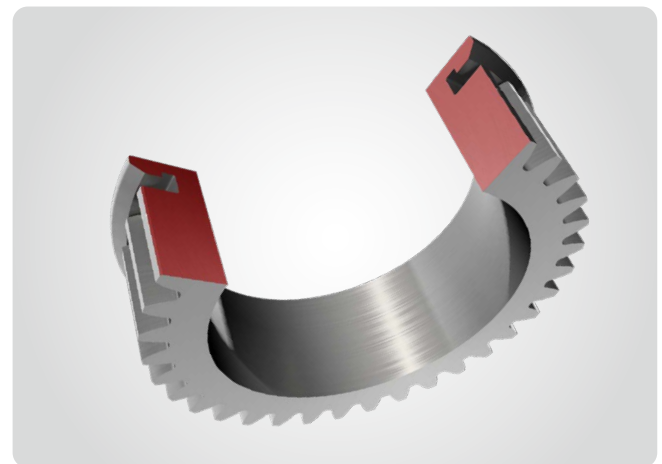

Außenverzahnung mit Schulter
External gearing with shoulder

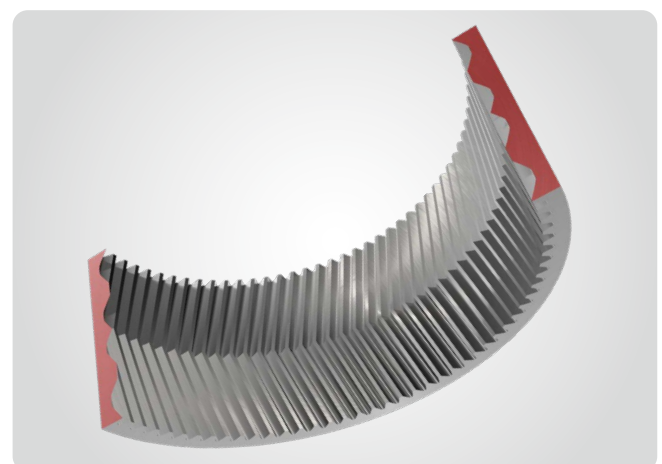

Pfeilverzahnung
Herringbone gearing



Schneidrad
Shaper

Schneidrad BP II (DIN 3972)
Shaper BP II (DIN 3972)

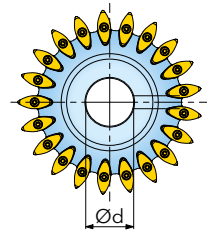
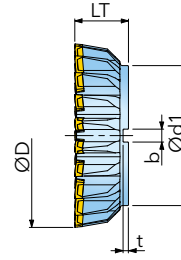

Modul Module	Artikel-Nr. Designation	D	D ₀	d	LT	Z	d1	b	t	Passende WSP Fitting insert
3	74X8D116003AG-02	115,5	108	31,75	40	36	88	12	4	A
	74X8D134003AJ-02	133,5	125	44,45	40	42	106	12	4	A
	74X8D152003AJ-02	151,5	144	44,45	40	48	124	12	4	A
4	74X8D090004AG-02	90	80	31,75	40	20	68	12	4	B
	74X8D114004AG-02	114	104	31,75	40	26	92	12	4	B
	74X8D130004AJ-02	130	120	44,45	40	30	108	12	4	B
5	74X8D113005AG-02	112,5	100	31,75	40	20	82	12	4	C
	74X8D143005AJ-02	142,5	130	44,45	40	26	112	12	4	C
	74X8D163005AJ-02	162,5	150	44,45	40	30	132	12	4	C
6	74X8D135006AG-02	135	120	31,75	40	20	91	12	4	D
	74X8D171006AJ-02	171	156	44,45	40	26	127	12	4	D
	74X8D195006AJ-02	195	180	44,45	40	30	151	12	4	D
7	74X8D158007AJ-02	157,5	140	44,45	40	20	108	12	4	E
	74X8D200007AJ-02	199,5	182	44,45	40	26	150	12	4	E
	74X8D228007BG-02	227,5	210	70	50	30	178	12	4	E
8	74X8D180008AJ-02	180	160	44,45	40	20	122	12	4	F
	74X8D228008BG-02	228	208	70	40	26	170	12	4	F
	74X8D260008BG-02	260	240	70	50	30	202	12	4	F
9	74X8D203009AJ-02	202,5	180	44,45	40	20	139	12	4	G
	74X8D257009BG-02	256,5	234	70	50	26	193	12	4	G
	74X8D293009BG-02	292,5	270	70	50	30	229	12	4	G
10	74X8D225010AJ-02	205	180	44,45	40	18	150	12	4	H
	74X8D225010BG-02	225	200	70	50	20	170	12	4	H
	74X8D455010BG-02	245	220	70	50	22	190	12	4	H
11	74X8D223011AJ-02	225,5	198	44,45	40	18	166	12	4	I
	74X8D248011BG-02	247,5	220	70	50	20	188	12	4	I
	74X8D270011BG-02	269,5	242	70	50	22	210	12	4	I
12	74X8D222012AJ-02	222	192	44,45	40	16	145	12	4	J
	74X8D246012BG-02	246	216	70	50	18	170	12	4	J
	74X8D270012BG-02	270	240	70	50	20	195	12	4	J
13	74X8D241013BG-02	240,5	208	70	50	16	150	12	4	K
	74X8D267013BG-02	266,5	234	70	50	18	175	12	4	K
	74X8D293013BJ-02	292,5	260	100	50	20	205	12	4	K
14	74X8D259014BG-02	259	224	70	50	16	170	12	4	L
	74X8D287014BJ-02	287	252	100	50	18	200	12	4	L
	74X8D263015BJ-02	262,5	225	100	50	15	180	12	4	M
15	74X8D293015BJ-02	292,5	255	100	50	17	200	12	4	M
	74X8D280016BJ-02	280	240	100	50	15	190	12	4	N
	74X8D296016BJ-02	296	256	100	50	16	200	12	4	N
17	74X8D300017BJ-02	297,5	255	100	50	15	200	12	4	O
	74X8D315018BJ-02	315	226	100	50	15	200	12	4	P

ZUBEHÖR / SPARE PARTS

Senkschraube / Insert screw

SM30-082-20

für Platten / for inserts:

A



Senkschraube / Insert screw

SM40-110-00

für Platten / for inserts:

B



Senkschraube / Insert screw

SM40-130-00

für Platten / for inserts:

C



Senkschraube / Insert screw











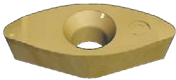





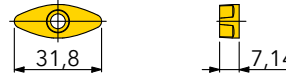



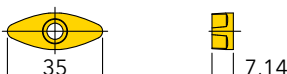

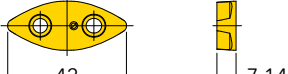
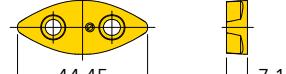

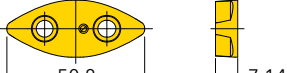

SM50-140-10

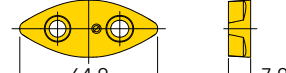
für Platten / for inserts:

D E F G H I J K L M N O P

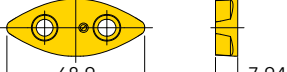

WENDESCHNEIDPLATTEN / INSERTS

A VCDV0303	B VCDV0404	C VCDV0506	D VCDV0607
			
			
E VCDV0707	F VCDV0807	G VCDV0907	H VCDV1007
			
			
I VCDV1107	J VCDV1207	K VCDV1307	L VCDV1407
			
			
M VCDV1507	N VCDV1607	O VCDV1707	P VCDV1807
			
			

Schneidräder werden im Allgemeinen für Geradzahnung in der Güteklasse B nach DIN 1829 gefertigt. Schneidräder für Schrägverzahnung auf Anfrage.
 Shapers are generally produced for spur gears in class B according to DIN 1829. Shapers for helical gears on request.

Artikel-Nr. Designation	Ausführung Description	Qualität Grade	IN2030	IN2530
VCDV_	positive Geometrie / positive geometry			

● = P ● = M ● = K ● = N ● = S ○ = H

Vorstoßen eines Innenrades

Modul 6, $z = -77$, $b = 170$ mm, Werkstoff: 42CrMo4

Schneidrad mit $z = 36$:

$n = 141$ DH/min

$Sr = 0,0024 - 0,0013$ mm/DH

$Sw = 1,885$ mm/DH

$ae = 12,2$ mm

Shaping of an internal wheel

module 6, $z = -77$, $b = 170$ mm, material: 42CrMo4

Shaper with $z = 36$:

$n = 141$ DS/min

$Sr = 0,0024 - 0,0013$ mm/DS

$Sw = 1,885$ mm/DS

$ae = 12,2$ mm



Schneidrad
Shaper



Schneidrad (DIN 5480)
Shaper (DIN 5480)

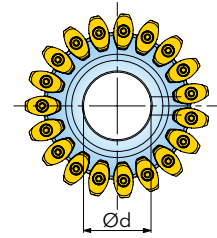
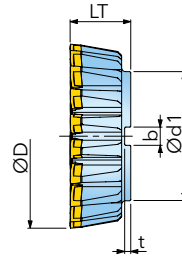

Modul Module	Artikel-Nr. Designation	D	D ₀	d	LT	Z	d ₁	b	t	Passende WSP Fitting insert
3	74X8D112003AG-54	111,9	108	31,75	40	36	85	12	4	A
	74X8D130003AJ-54	129,9	125	44,45	40	42	100	12	4	A
	74X8D148003AJ-54	147,9	144	44,45	40	48	120	12	4	A
4	74X8D085004AG-54	85,2	80	31,75	40	20	73	12	4	B
	74X8D109004AG-54	109,2	104	31,50	40	26	97	12	4	B
	74X8D125004AJ-54	125,2	120	44,45	40	30	113	12	4	B
5	74X8D107005AG-54	106,5	100	31,50	40	20	88	12	4	C
	74X8D137005AJ-54	136,5	130	44,45	40	26	118	12	4	C
	74X8D157005AJ-54	156,5	150	44,45	40	30	138	12	4	C
6	74X8D128006AG-54	127,8	120	31,75	40	20	102	12	4	D
	74X8D164006AJ-54	163,8	156	44,45	40	26	138	12	4	D
	74X8D188006AJ-54	187,8	180	44,45	40	30	162	12	4	D
7	74X8D149007AJ-54	149,1	140	44,45	40	20	115	12	4	E
	74X8D191007AJ-54	191,1	182	44,45	40	26	157	12	4	E
	74X8D219007BG-54	219,1	210	70	50	30	185	12	4	E
8	74X8D170008AJ-54	170,4	160	44,45	40	20	130	12	4	F
	74X8D218008BG-54	218,4	208	70	50	26	178	12	4	F
	74X8D250008BG-54	250,4	240	70	50	30	210	12	4	F
9	74X8D192009AJ-54	191,7	180	44,45	40	20	143	12	4	G
	74X8D246009BG-54	245,7	234	70	50	26	197	12	4	G
	74X8D282009BG-54	281,7	270	70	50	30	233	12	4	G
10	74X8D293010AJ-54	193	180	44,45	40	18	150	12	4	H
	74X8D213010BG-54	213	200	70	50	20	155	12	4	H
	74X8D233010BG-54	233	220	70	50	22	160	12	4	H
11	74X8D223011AJ-54	225,5	198	44,45	40	18	166	12	4	I
	74X8D248011BG-54	247,5	220	70	50	20	188	12	4	I
	74X8D270011BG-54	269,5	242	70	50	22	210	12	4	I
12	74X8D222012AJ-54	222	192	44,45	40	16	145	12	4	J
	74X8D246012BG-54	246	216	70	50	18	170	12	4	J
	74X8D270012BG-54	270	240	70	50	20	195	12	4	J
13	74X8D241013BG-54	240,5	208	70	50	16	150	12	4	K
	74X8D267013BG-54	266,5	234	70	50	18	175	12	4	K
	74X8D293013BJ-54	292,5	260	100	50	20	205	12	4	K
14	74X8D259014BG-54	259	224	70	50	16	170	12	4	L
	74X8D287014BJ-54	287	252	100	50	18	200	12	4	L
	74X8D263015BJ-54	262,5	225	100	50	15	180	12	4	M
15	74X8D293015BJ-54	292,5	255	100	50	17	200	12	4	M
	74X8D280016BJ-54	280	240	100	50	15	190	12	4	N
16	74X8D296016BJ-54	296	256	100	50	16	200	12	4	N
	74X8D300017BJ-54	297,5	255	100	50	15	200	12	4	O
17	74X8D300017BJ-54	297,5	255	100	50	15	200	12	4	O
18	74X8D315018BJ-54	315	226	100	50	15	200	12	4	P

ZUBEHÖR/SPARE PARTS

Senkschraube / Insert screw

SM30-082-20

für Platten / for inserts:

A



Senkschraube / Insert screw

SM40-110-00

für Platten / for inserts:

B



Senkschraube / Insert screw

SM40-130-00

für Platten / for inserts:

C



Senkschraube / Insert screw





















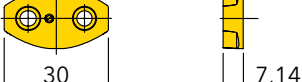

SM50-140-10

für Platten / for inserts:

D E F G H I J K L M N O P

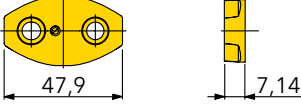
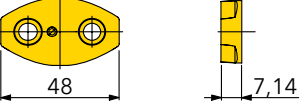
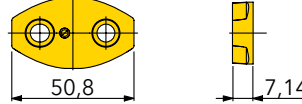
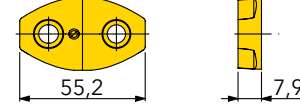

HM-SCHNEIDPLATTEN / SOLID CARBIDE INSERTS

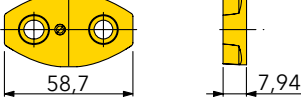
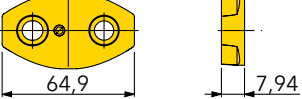
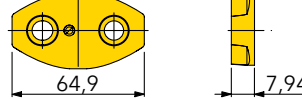
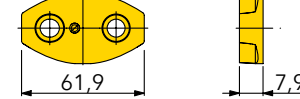
A VCDV0303-DIN5480	B VCDV0404-DIN5480	C VCDV0506-DIN5480	D VCDV0607-DIN5480
			
			
E VCDV0707-DIN5480	F VCDV0807-DIN5480	G VCDV0907-DIN5480	H VCDV1007-DIN5480
			
			
I VCDV1107-DIN5480	J VCDV1207-DIN5480	K VCDV1307-DIN5480	L VCDV1408-DIN5480
			
			
M VCDV1508-DIN5480	N VCDV1608-DIN5480	O VCDV1708-DIN5480	P VCDV1808-DIN5480
			
			

Schneidräder werden im Allgemeinen für Geradzahnung in der Güteklasse B nach DIN 1829 gefertigt. Schneidräder für Schrägverzahnung auf Anfrage.
 Shapers are generally produced for spur gears in class B according DIN 1829. Shapers for helical gears on request.

Artikel-Nr. Designation	Ausführung Description	Qualität Grade	IN2030	IN2530
VCDV_	positive Geometrie / positive geometry			

● = P ● = M ● = K ● = N ● = S ○ = H

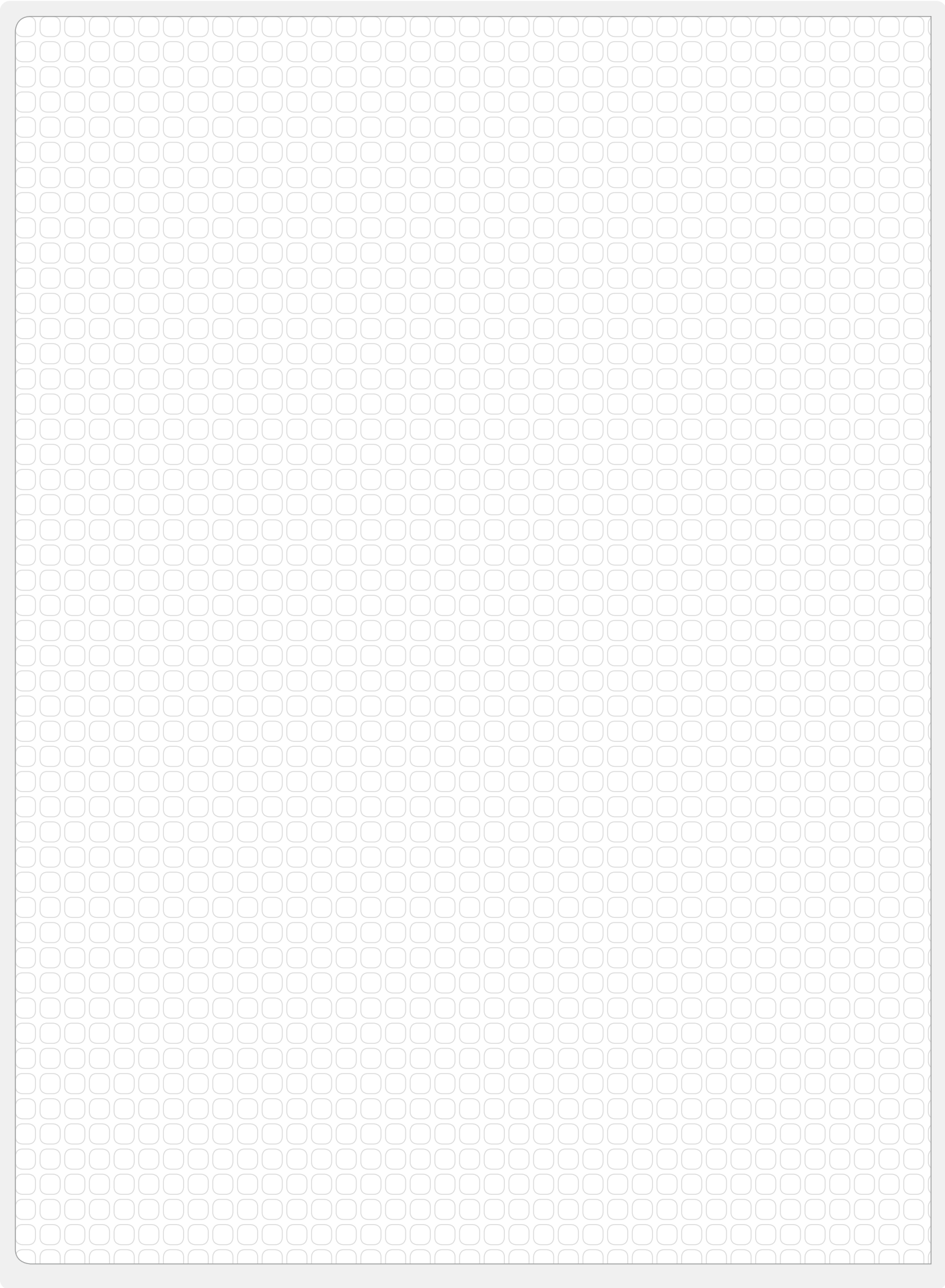



Allgemeine Beschreibung / General Description

Die Entwicklung des Wälzschälens geht schon auf den Beginn des zwanzigsten Jahrhunderts zurück. Das neue Verfahren zur Herstellung von Verzahnungen wurde dann auch im Jahre 1910 durch Wilhelm von Pittler zum Patent angemeldet. Obwohl das Wälzschälens hohes Potential bei Produktivität und Flexibilität versprach, konnte es sich in der Praxis nicht durchsetzen und geriet in Vergessenheit. Die technischen Möglichkeiten der damaligen Zeit waren in den Bereichen Maschinensteuerung und Werkzeugperformance für dieses Hochleistungsbearbeitungsverfahren noch nicht gegeben. Durch enorme Fortschritte sowohl bei den Werkzeugmaschinen als auch bei den Werkzeugen durch moderne Schneidstoffe und Beschichtungen ist das Wälzschälens mittlerweile für serielle Einsätze geeignet und verspricht eine interessante Alternative zu den etablierten Verfahren wie Wälzfräsen und Wälzstoßen zu werden.

Das Wälzschälens ist ein kontinuierliches spanabhebendes Verfahren zur Herstellung von sogenannten rotationssymmetrischen periodischen Strukturen, in erster Linie Verzahnungen. Das Wälzschälwerkzeug und das Werkrad wälzen mit gekreuzten Achsen entsprechend einer Schraubradpaarung. Bei der Schraubradpaarung teilt sich die Bewegung in einen wälzenden und einen schraubenden Teil auf, der beim Wälzschälens zu einer gleitenden Schnittbewegung wird. Je größer man den Achskreuzwinkel wählt umso mehr nehmen der wälzende Anteil ab und der schraubende Anteil zu, was zu einer Vergrößerung der Schnittgeschwindigkeit führt. Einzig durch die Veränderung der Achsanordnung und die Drehzahl von Werkzeug und Werkrad lässt sich die Schnittgeschwindigkeit verändern. Wälzschälrad und Werkrad erhalten Drehbewegungen, die zueinander im Verhältnis der Zahnzahlen z_2/z_0 stehen. Der Achskreuzwinkel Σ ist bei gegensinnigen Flankenrichtungen gleich der Differenz, bei gleichsinnigen Flankenrichtungen gleich der Summe der Schrägungswinkel des Schälrades β_0 und des Werkrades β_2 .



Development of gear skiving has been started at the beginning of the twentieth century. The new machining process for production of gears was then applied for a patent by Wilhelm von Pittler in 1910. Although gear skiving promised great potential in terms of productivity and flexibility, it was not successful in practice and was forgotten. The technical possibilities of that time were not yet available in the areas of machine control and tool performance for this high-performance machining process. Thanks to enormous progress in both machine tools and tools, thanks to modern cutting materials and coatings, gear skiving is now suitable for serial production and promises to be an interesting alternative to the established machining processes such as hobbing and gear shaping

Gear skiving is a continuous cutting process for the production of so-called rotationally symmetrical periodic structures, primarily gears. The skiving tool and the work gear rotate with crossed axes according to a helical gear pair. With the helical gear pairing, the movement is divided into a rolling and a screwing part, which becomes a sliding cutting movement when skiving. The larger you choose the cross-axis angle, the more the rolling component decreases and the screwing component increases, which leads to an increase of cutting speed. Cutting speed can only be varied by changing axis arrangement and speed of tool and work gear. Skiving tool and work gear receive rotary movements that are related to each other in the ratio of the number of teeth z_2/z_0 . The cross-axis angle Σ is equal to the difference in the case of opposing flank directions; in the case of flank directions in the same direction, it is equal to the sum of the helical angles of skiving tool β_0 and work gear β_2 .

Vereinfacht gesehen, kann man das Wälzschälen als eine Kombination des Wälzfräsens und Stoßens betrachten, wobei es einige Vorteile der genannten Verfahren in sich vereint. In erster Linie sind dies die Produktivität des Wälzfräsens und die Flexibilität des Wälzstoßens. Besonders bei der Innenverzahnung im Vergleich zum Wälzstoßen kann das Wälzschälverfahren durch wesentlich höhere Produktivität punkten. Die Bearbeitungszeiten liegen beim Wälzschälen etwa bei 30% bis 50% verglichen mit dem Wälzstoßverfahren. Das Wälzschälen benötigt im Gegensatz zum Wälzstoßen durch die Schrägstellung des Werkzeuges gegenüber dem Werkstück (Achskreuzwinkel) jedoch einen Bearbeitungsweg, der etwas größer ist als die Breite der zu erzeugenden Verzahnung. Diese Zusatzwege bezeichnet man als Ein- und Überlaufwege. Sie nehmen mit steigendem Achskreuzwinkel zu. Durch diese notwendigen Ein- und Überlaufwege hat das Wälzschälen gegenüber dem Stoßen geringe Einschränkungen bei sehr engen Innenverzahnungen und Störkonturen. Für die Mehrzahl der Anwendungsfälle, die bisher dem Wälzstoßen vorbehalten waren, ist jedoch das Wälzschälen eine wesentlich produktivere und wirtschaftlichere Bearbeitungsmethode.

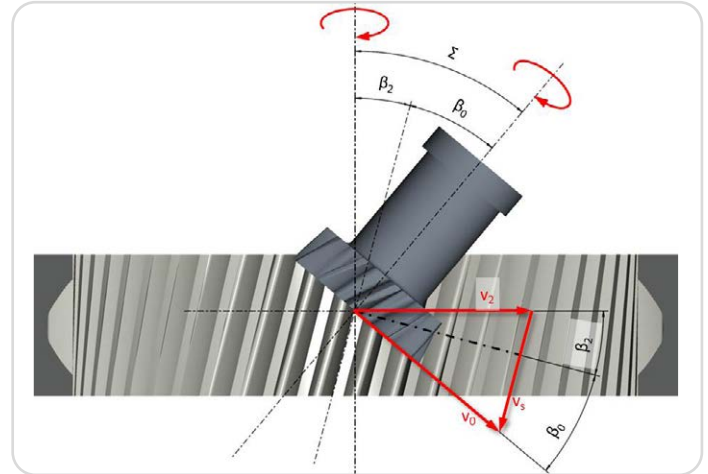

- Σ : Achskreuzungswinkel / cross-axis angle
- β_0 : Werkzeugschrägungswinkel / helical angle of tool
- β_2 : Werkradsschrägungswinkel / helical angle of gear
- v_2 : Schnittgeschwindigkeit Werkrad / cutting speed work gear
- v_0 : Schnittgeschwindigkeit Werkzeug / cutting speed tool
- v_s : resultierende Schnittgeschwindigkeit / resulting cutting speed

In simple terms, gear skiving can be viewed as a combination of hobbing and gear shaping, combining some of the advantages of both machining processes. Primarily, these are the productivity of hobbing and the flexibility of gear shaping. Especially when machining internal gears compared to gear shaping, the gear skiving process scores with significantly higher productivity. Machining times for gear skiving are around 30% to 50% compared to the gear shaping process. In contrast to gear shaping, however, due to the inclined position of the tool in relation to the workpiece (cross-axis angle), gear skiving requires a machining path that is slightly larger than the width of the gearing to be produced. These additional paths are called approach and overrun distance. They increase as the cross-axis angle increases. Due to these necessary approach and overrun distances, gear skiving has few restrictions compared to gear shaping with very narrow internal gears and interfering contours. For the majority of applications that were previously reserved for gear shaping, gear skiving is a much more productive and economical machining method.

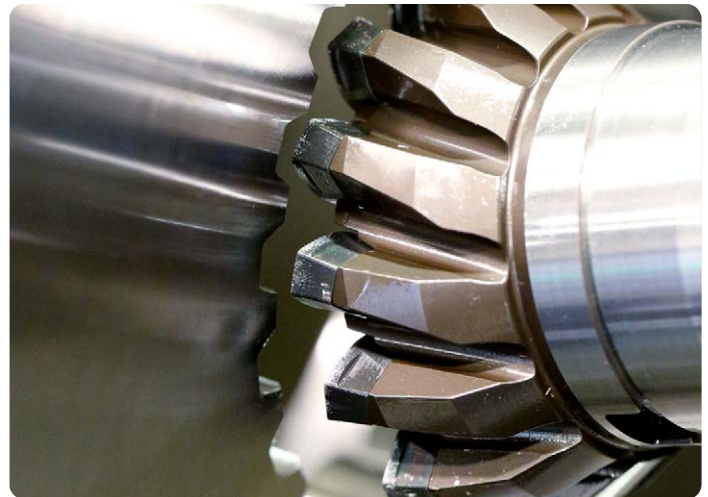



Wälzschälrad
 Skiving cutter

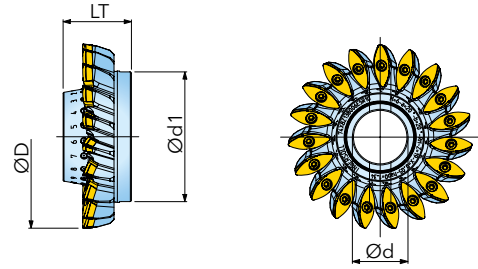

Modul Module	Artikel-Nr. Designation	D	D ₀	d	LT	z	d1	α	β	Passende WSP Fitting insert
3	74X8Z094003AG-02	94	86,5	31,75	40	27	76	20	20	A
	74X8Z106003AG-02	106	98,5	31,75	40	31	88	20	20	A
	74X8Z152003AJ-02	132	124,5	44,45	40	39	114	20	20	A
4	74X8Z091004AG-02	91	81	31,75	40	19	67	20	20	B
	74X8Z108004AG-02	108	98	31,75	40	23	84	20	20	B
	74X8Z133004AJ-02	133	123	44,45	40	29	109	20	20	B
5	74X8Z114005AG-02	114	101,5	31,75	40	19	84	20	20	C
	74X8Z135005AJ-02	135	122,5	44,45	40	23	105	20	20	C
	74X8Z167005AJ-02	167	154,5	44,45	40	29	137	20	20	C
6	74X8Z136006AG-02	136	121	31,75	40	19	100	20	20	D
	74X8Z171006AJ-02	162	147	44,45	40	23	126	20	20	D
	74X8Z200006AJ-02	200	185	44,45	40	29	164	20	20	D
7	74X8Z159007AJ-02	159	141,5	44,45	40	19	117	20	20	E
	74X8Z216007AJ-02	189	171,5	44,45	40	23	147	20	20	E
	74X8Z267007BG-02	234	216,5	70	50	29	192	20	20	E
8	74X8Z164008AJ-02	164	144	44,45	40	17	116	20	20	F
	74X8Z182008BG-02	182	162	70	50	19	134	20	20	F
	74X8Z216008BG-02	216	196	70	50	23	168	20	20	F
9	74X8Z204009AJ-02	185	162,5	44,45	40	17	131	20	20	G
	74X8Z205009BG-02	205	182,5	70	50	19	151	20	20	G
	74X8Z243009BG-02	243	220,5	70	50	23	189	20	20	G
10	74X8Z185010AJ-02	185	160	44,45	40	15	125	20	20	H
	74X8Z206010BG-02	206	181	70	50	17	146	20	20	H
	74X8Z249010BG-02	249	224	70	50	21	189	20	20	H
11	74X8Z203011AJ-02	203	175,5	44,45	40	15	137	20	20	I
	74X8Z227011BG-02	227	199,5	70	50	17	161	20	20	I
	74X8Z250011BG-02	250	222,5	70	50	19	184	20	20	I
12	74X8Z222012AJ-02	222	192	44,45	40	15	150	20	20	J
	74X8Z247012BG-02	247	217	70	50	17	175	20	20	J
	74X8Z272012BG-02	272	242	70	50	19	200	20	20	J

ZUBEHÖR/SPARE PARTS

Senkschraube / Insert screw

SM30-082-20

für Platten / for inserts:

A



Senkschraube / Insert screw

SM40-110-00

für Platten / for inserts:

B



Senkschraube / Insert screw

SM40-130-00

für Platten / for inserts:

C



Senkschraube / Insert screw











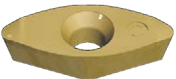

SM50-140-10

für Platten / for inserts:

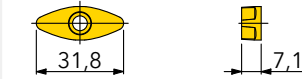
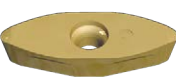

D E F G H I J

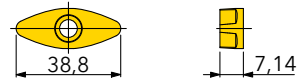
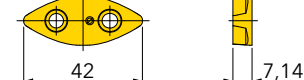
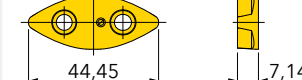

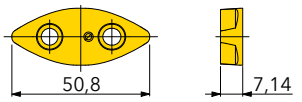
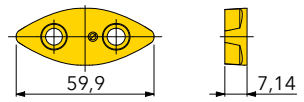
HM-SCHNEIDPLATTEN / SOLID CARBIDE INSERTS

A VCDW0303	B VCDW0404	C VCDW0506	D VCDW0607
			
			
E VCDW0707	F VCDW0807	G VCDW0907	H VCDW1007
			
			
I VCDW1107	J VCDW1207		
			
			

Wälzschälräder werden im Allgemeinen für Geradverzahnung in der Güteklasse B nach DIN 1829 gefertigt. Wälzschälräder für Schrägverzahnung auf Anfrage.
 Skiving Cutter are generally produced for spur gears in class B according DIN 1829. Skiving Cutter for helical gears on request.

Artikel-Nr. Designation	Ausführung Description	Qualität Grade	IN2030	IN2530
VCDW_	positive Geometrie / positive geometry			

● = P ● = M ● = K ● = N ● = S ○ = H

Wälzschälrad
 Skiving cutter

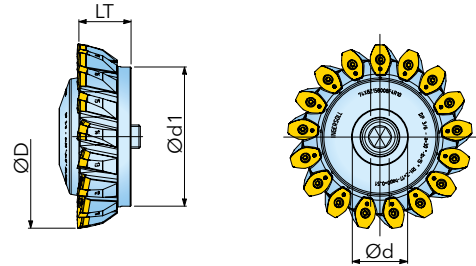

Modul Module	Artikel-Nr. Designation	D	D ₀	d	LT	z	d ₁	α	β	Passende WSP Fitting insert
3	74X8Z086003AG-54	86	78,7	31,75	40	27	74	30	20	A
	74X8Z099003AG-54	99	91,5	31,75	40	31	87	30	20	A
	74X8Z125003AJ-54	125	117	44,45	40	39	113	30	20	A
4	74X8Z081004AG-54	81	70,9	31,75	40	19	65	30	20	B
	74X8Z098004AG-54	98	87,9	31,75	40	23	82	30	20	B
	74X8Z123004AJ-54	123	113	44,45	40	29	107	30	20	B
5	74X8Z101005AG-54	101	88,6	31,75	40	19	81	30	20	C
	74X8Z122005AJ-54	122	110	44,45	40	23	102	30	20	C
	74X8Z154005AJ-54	154	142	44,45	40	29	134	30	20	C
6	74X8Z121006AG-54	121	106	31,75	40	19	97	30	20	D
	74X8Z147006AJ-54	147	132	44,45	40	23	123	30	20	D
	74X8Z185006AJ-54	185	170	44,45	40	29	161	30	20	D
7	74X8Z142007AJ-54	142	124	44,45	40	19	114	30	20	E
	74X8Z171007AJ-54	171	154	44,45	40	23	143	30	20	E
	74X8Z216007BG-54	216	199	70	50	29	188	30	20	E
8	74X8Z145008AJ-54	145	125	44,45	40	17	113	30	20	F
	74X8Z162008BG-54	162	142	70	50	19	130	30	20	F
	74X8Z196008BG-54	196	176	70	50	23	164	30	20	F
9	74X8Z163009AJ-54	163	140	44,45	40	17	127	30	20	G
	74X8Z182009BG-54	182	159	70	50	19	146	30	20	G
	74X8Z220009BG-54	220	198	70	50	23	184	30	20	G
10	74X8Z160010AJ-54	160	135	44,45	40	15	120	30	20	H
	74X8Z181010BG-54	181	156	70	50	17	141	30	20	H
	74X8Z223010BG-54	223	198	70	50	21	183	30	20	H
11	74X8Z176011AJ-54	176	148	44,45	40	15	132	30	20	I
	74X8Z199011BG-54	199	171	70	50	17	155	30	20	I
	74X8Z222011BG-54	222	195	70	50	19	178	30	20	I
12	74X8Z192012AJ-54	192	162	44,45	40	15	144	30	20	J
	74X8Z217012BG-54	217	187	70	50	17	169	30	20	J
	74X8Z243012BG-54	243	213	70	50	19	195	30	20	J

ZUBEHÖR/SPARE PARTS

Senkschraube / Insert screw

SM30-082-20

für Platten / for inserts:

A



Senkschraube / Insert screw

SM40-110-00

für Platten / for inserts:

B



Senkschraube / Insert screw

SM40-130-00

für Platten / for inserts:

C



Senkschraube / Insert screw





















SM50-140-10

für Platten / for inserts:



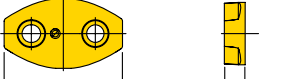

D E F G H I J



HM-SCHNEIDPLATTEN / SOLID CARBIDE INSERTS

A VCDW0303-DIN5480	B VCDW0404-DIN5480	C VCDW0506-DIN5480	D VCDW0607-DIN5480
			
			
E VCDW0707-DIN5480	F VCDW0807-DIN5480	G VCDW0907-DIN5480	H VCDW1007-DIN5480
			
			
I VCDW1107-DIN5480	J VCDW1207-DIN5480		
			
			

Wälzschälräder werden im Allgemeinen für Geradverzahnung in der Güteklasse B nach DIN 1829 gefertigt. Wälzschälräder für Schrägverzahnung auf Anfrage.
 Skiving Cutter are generally produced for spur gears in class B according DIN 1829. Skiving Cutter for helical gears on request.

Artikel-Nr. Designation	Ausführung Description	Qualität Grade	IN2030	IN2530
VCDW_	positive Geometrie / positive geometry			
				

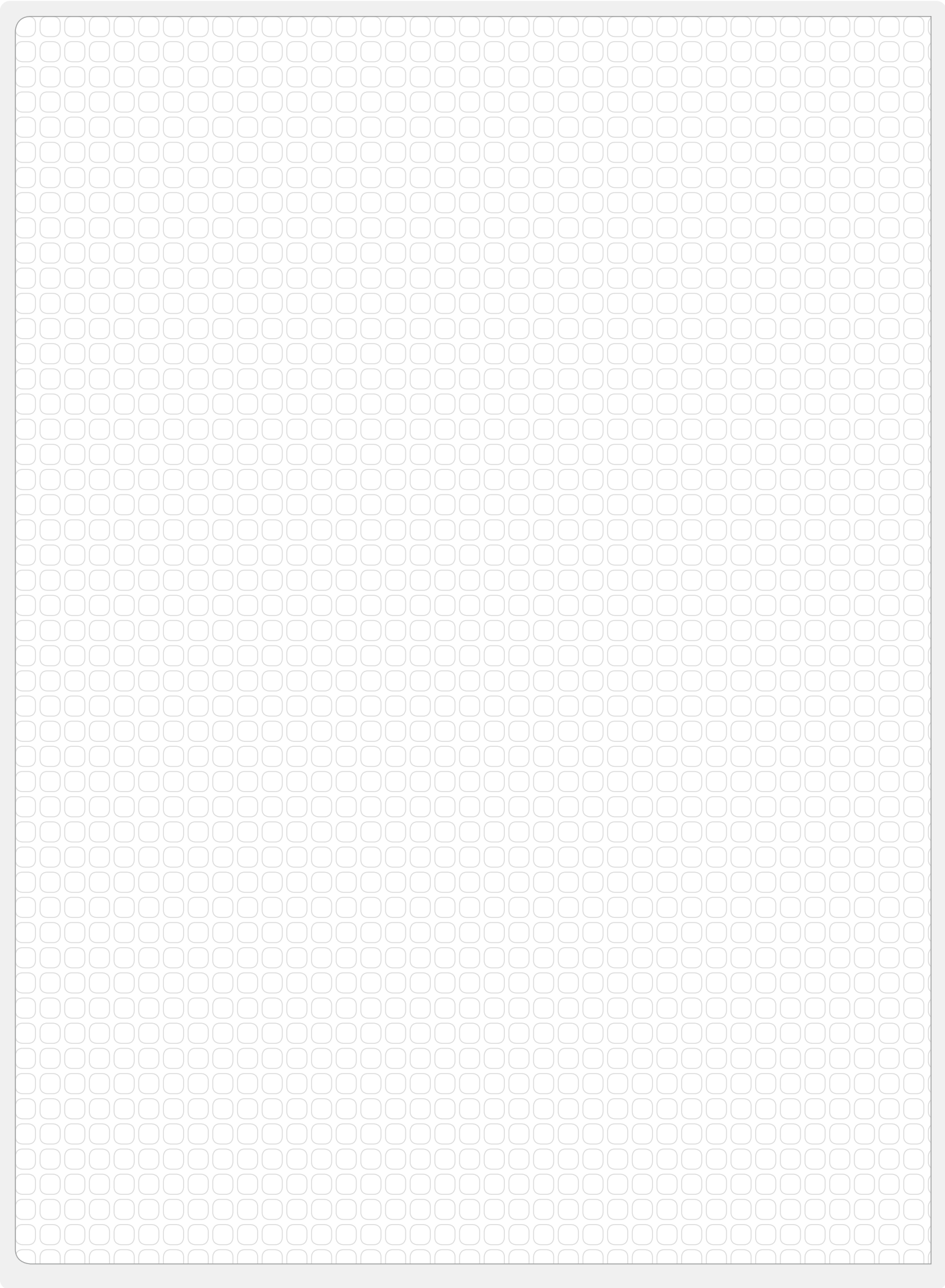

GEAR GASH
GEAR SHAPE
GEAR SKIVE



Verzahnungsarten / Application range

**Laufverzahnung (außen) /
Involute gear (external)**



DIN 3960 / 3972
20° Eingriffswinkel
Zahnhöhe 2,25 x m
Gerad- und schrägverzahnt

*DIN 3960 / 3972
20° pressure angle
Tooth height 2,25 x m
Spur & helical teeth*

**Steckverzahnung (außen) /
Spline gear (external)**



DIN 5480
30° Eingriffswinkel
Zahnhöhe 1,10 x m
In der Regel nur geradverzahnt

*DIN 5480
30° pressure angle
Tooth height 1,10 x m
Normally only spur teeth*

**Laufverzahnung (innen) /
Involute gear (internal)**



DIN 3960 / 3972
20° Eingriffswinkel
Zahnhöhe 2,25 x m
Gerad- und schrägverzahnt

*DIN 3960 / 3972
20° pressure angle
Tooth height 2,25 x m
Spur & helical teeth*

**Steckverzahnung (innen) /
Spline gear (internal)**



DIN 5480
30° Eingriffswinkel
Zahnhöhe / tooth height 1,10 x m
In der Regel nur geradverzahnt

*DIN 5480
30° pressure angle
Tooth height 2,25 x m
Normally only spur teeth*

Sonderlösungen mit ChipSurfer / Special Solutions with ChipSurfer

Rohling / Blank:



Durchmesser: 17,0 mm bis 35,0 mm
 Schnittbreite: 1,9 mm bis 16 mm
 Schnitttiefe: bis 6 mm
 Modulgrößen: Modul 0,8 - 3,5
 Diameter: 17,0 mm to 35,0 mm
 Cutting width: 1,9 mm to 16 mm
 Cutting depth: to 6 mm
 Module sizes: module 0,8 - 3,5

Beispiel / Example:

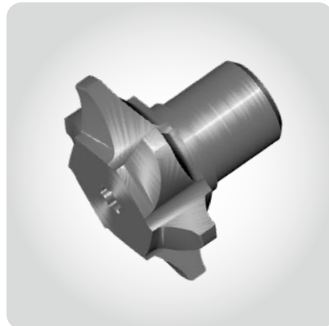

ChipSurfer 18Z25002TRRA061 IN2030



Schlichtfräser Modul 2; z = 23
 Gear finish mill module 2; z = 23

Rohling / Blank



Durchmesser: 8 mm bis 25 mm
 Schnittbreite: 10 mm bis 25 mm
 Schnitttiefe: bis 6 mm
 Modulgrößen: Modul 2,5 bis 12

Cutting depth: to 6 mm
 Cutting width: 10 mm to 25 mm
 Diameter: 8 mm to 25 mm
 Module sizes: module 2.5 to 12

Beispiel / Example:



Schlichtfräser Modul 12; z = 128
 Gear finish end mill module 12; z = 128

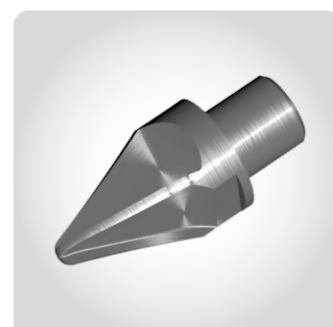

ChipSurfer 47Z04037TURA10 IN2005

CHIPSURFER ZAHNFORMFRÄSER BP II (DIN 3972)
CHIPSURFER GEAR FINISHING GASHER BP II (DIN 3972)

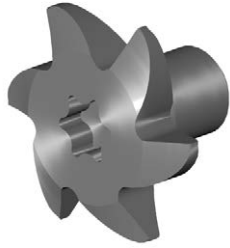

Zahnformfräser
 Gear Finishing Gasher

(DIN 3972)
 (DIN 3972)

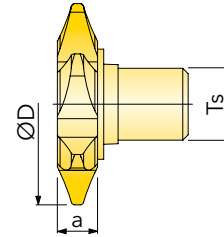

Modul Module	Artikel-Nr. Designation	D	a max	Ts	z	α	β
0,8 - 1,5	18Z170MMT6-02	17	5	6	6	20	0
1,5 - 2,0	18Z230MMT8-02	23	9,9	8	6	20	0
2,0 - 2,5	18Z280MMTR-02	28	10,3	10	6	20	0
2,5 - 3,3	18Z350MMTS-02	35	16	12	8	20	0

Artikel-Nr. Designation	Ausführung Description	Qualität Grade	IN2005	IN2030	IN2505
18Z_	positive Geometrie / positive geometry				

● = P ● = M ● = K ● = N ● = S ○ = H

CHIPSURFER ZAHNFORMFRÄSER (DIN 5480)
CHIPSURFER GEAR FINISHING GASHER (DIN 5480)

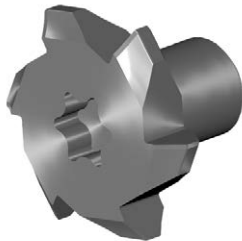

Zahnformfräser
 Gear Finishing Gasher

(DIN 5840)
 (DIN 5840)

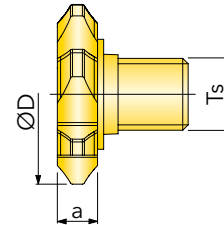

Modul Module	Artikel-Nr. Designation	D	a max	Ts	z	α	β
0,8 - 1,5	18Z170MMT6-54	17	5	6	6	30	0
1,5 - 2,0	18Z230MMT8-54	23	9,9	8	6	30	0
2,0 - 4,0	18Z280MMTR-54	28	10,3	10	6	30	0
4,0 - 5,5	18Z350MMTS-54	35	16	12	8	30	0

Artikel-Nr. Designation	Ausführung Description	Qualität Grade	IN2005	IN2030	IN2505
18Z_	positive Geometrie / positive geometry				

● = P ● = M ● = K ● = N ● = S ○ = H

Sonderlösungen mit ChipSurfer / Special Solutions with ChipSurfer

Modul (Laufverzahnung) / Module (spur gear)	0,4 - 1,0	0,4 - 1,3	0,4 - 1,6	0,4 - 2,0	0,4 - 6,0
Modul (Steckverzahnung) / Module (splines)	0,4 - 2,0	0,4 - 2,5	0,4 - 3,0	0,4 - 3,0	0,4 - 6,0
Durchmesserbereich / Diameter range	Ø 15 - 17	Ø 17 - 23	Ø 23 - 28	Ø 28 - 35	Ø 60 - 125
Rohling / Blanks					
mögliches Werkzeug / example of tools					
	74D16511T6R01	74Z23012T8RA101	74Z28020TRRA101	74Z35007TSRA101	74Z56025BAAA191

ChipSurfer-Aufnahmen siehe Katalog & WebShop / ChipSurfer-Adaption you will find in the catalog and webshop

Möglichkeiten des Nachschleifens / Regrinding of tools



Neues Werkzeug / New tool

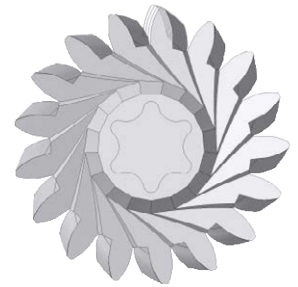

Komplett nachgeschliffenes Werkzeug / Completely reground tool

- Der Nachschliff erfolgt ausschließlich auf der Spanfläche
- Der Werkzeugdurchmesser ändert sich bei jedem Nachschliff
- Beim Einsatz von nachgeschliffenen Werkzeugen muss der Achs-
abstand und die Werkzeuglänge zwingend korrigiert werden

- *Regrinding takes place exclusively on the rake face*
- *Tool diameter changes with each regrinding*
- *When using reground tools, center distance and tool length must be
necessarily adapted*

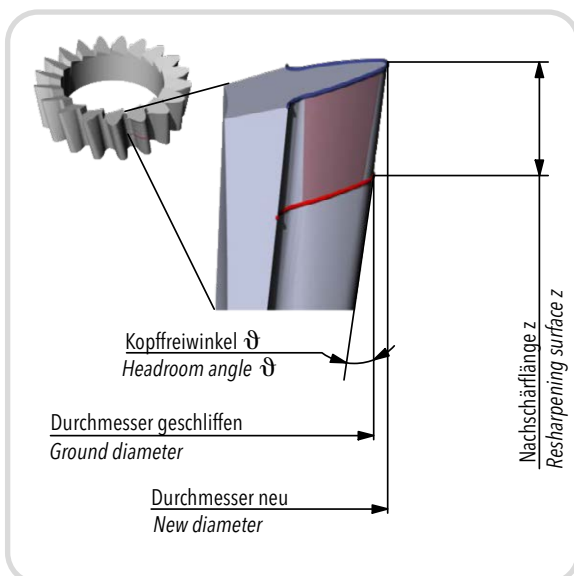

Schneidrad
Shaper



(DIN 3960 / 3972)
(DIN 3960 / 3972)

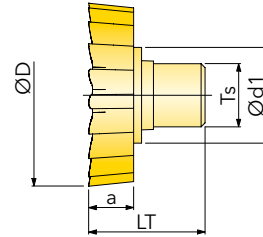

Modul Module	Artikel-Nr. Designation	D	d1	LT	a	Ts	z	α
0,4	74D1704T6R380	16,5	9,5	12,1	4,5	6	38	30
	74D2304T8R530	23	11,5	16,6	7	8	53	30
	74D2804T10R650	28	15,2	20,75	7,5	10	65	30
	74D3504T12R820	35	18,3	22	8,5	12	82	30
0,5	74D1705T6R300	16,5	9,5	12,1	4,5	6	30	30
	74D2305T8R420	23	11,5	16,6	7	8	42	30
	74D2805T10R520	28	15,2	20,75	7,5	10	52	30
	74D3505T12R650	35	18,3	22	8,5	12	65	30
0,6	74D1706T6R250	16,5	9,5	12,1	4,5	6	25	30
	74D2306T8R350	23	11,5	16,6	7	8	35	30
	74D2806T10R430	28	15,2	20,75	7,5	10	43	30
	74D3506T12R540	35	18,3	22	8,5	12	54	30
0,7	74D1707T6R210	16,5	9,5	12,1	4,5	6	21	30
	74D2307T8R300	23	11,5	16,6	7	8	30	30
	74D2807T10R370	28	15,2	20,75	7,5	10	37	30
	74D3507T12R460	35	18,3	22	8,5	12	46	30
0,8	74D1708T6R170	16,5	9,5	12,1	4,5	6	17	30
	74D2308T8R240	23	11,5	16,6	7	8	24	30
	74D2808T10R300	28	15,2	20,75	7,5	10	30	30
	74D3508T12R380	35	18,3	22	8,5	12	38	30
0,9	74D1709T6R160	16,5	9,5	12,1	4,5	6	16	30
	74D2309T8R230	23	11,5	16,6	7	8	23	30
	74D2809T10R280	28	15,2	20,75	7,5	10	28	30
	74D3509T12R350	35	18,3	22	8,5	12	35	30
1	74D1710T6R140	16,5	9,5	12,1	4,5	6	14	30
	74D2310T8R200	23	11,5	16,6	7	8	20	30
	74D2810T10R250	28	15,2	20,75	7,5	10	25	30
	74D3510T12R320	35	18,3	22	8,5	12	32	30
1,1	74D2311T8R190	23	11,5	16,6	7	8	19	30
	74D2811T10R230	28	15,2	20,75	7,5	10	23	30
	74D3511T12R290	35	18,3	22	8,5	12	29	30
	74D2312T8R170	23	11,5	16,6	7	8	17	30
1,2	74D2312T8R210	28	15,2	20,75	7,5	10	21	30
	74D3512T12R260	35	18,3	22	8,5	12	26	30
	74D2313T8R160	23	11,5	16,6	7	8	16	30
	74D2813T8R190	28	15,2	20,75	7,5	10	19	30
1,3	74D3513T12R240	35	18,3	22	8,5	12	24	30
	74D2314T8R140	23	11,5	16,6	7	8	14	30
	74D2814T8R180	28	15,2	20,75	7,5	10	18	30
	74D3514T12R220	35	18,3	22	8,5	12	22	30
1,5	74D2815T12R160	28	18,3	22	8,5	12	16	30
	74D3515T12R210	35	18,3	22	8,5	12	21	30
	74D2816T12R150	28	18,3	22	8,5	12	15	30
	74D3516T12R190	35	18,3	22	8,5	12	19	30
1,7	74D2817T12R140	28	18,3	22	8,5	12	14	30
	74D3517T12R180	35	18,3	22	8,5	12	18	30
	74D3518T12R170	35	18,3	22	8,5	12	17	30
	74D3519T12R160	35	18,3	22	8,5	12	16	30
2	74D3520T12R150	35	18,3	22	8,5	12	15	30
2,1	74D3520T12R140	35	18,3	22	8,5	12	14	30

Artikel-Nr. Designation	Ausführung Description	Qualität Grade	IN2005	IN2030	IN2505
74D_	positive Geometrie / positive geometry				

● = P ● = M ● = K ● = N ● = S ○ = H



Schneidrad
Shaper

(DIN 5480)
(DIN 5480)

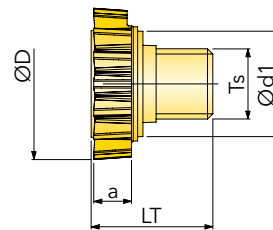

Modul Module	Artikel-Nr. Designation	D	d1	LT	a	Ts	z	α
0,4	74D1704T6RB360	16,5	9,5	12,1	4,5	6	36	20
	74D2304T8RB510	23	11,5	16,6	7	8	51	20
	74D2804T10RB630	28	15,2	20,75	7,5	10	63	20
	74D3504T12RB800	35	18,3	22	8,5	12	80	20
0,5	74D1705T6RB280	16,5	9,5	12,1	4,5	6	28	20
	74D2305T8RB400	23	11,5	16,6	7	8	40	20
	74D2805T10RB500	28	15,2	20,75	7,5	10	50	20
	74D3505T12RB630	35	18,3	22	8,5	12	63	20
0,6	74D1706T6RB230	16,5	9,5	12,1	4,5	6	23	20
	74D2306T8RB330	23	11,5	16,6	7	8	33	20
	74D2806T10RB410	28	15,2	20,75	7,5	10	41	20
	74D3506T12RB520	35	18,3	22	8,5	12	52	20
0,7	74D1707T6RB190	16,5	9,5	12,1	4,5	6	19	20
	74D2307T8RB280	23	11,5	16,6	7	8	28	20
	74D2807T10RB350	28	15,2	20,75	7,5	10	35	20
	74D3507T12RB440	35	18,3	22	8,5	12	44	20
0,8	74D1708T6RB170	16,5	9,5	12,1	4,5	6	17	20
	74D2308T8RB240	23	11,5	16,6	7	8	24	20
	74D2808T10RB300	28	15,2	20,75	7,5	10	30	20
	74D3508T12RB380	35	18,3	22	8,5	12	38	20
0,9	74D2309T8RB210	23	11,5	16,6	7	8	21	20
	74D2809T10RB260	28	15,2	20,75	7,5	10	26	20
	74D3509T12RB340	35	18,3	22	8,5	12	34	20
	74D2310T8RB190	23	11,5	16,6	7	8	19	20
1	74D2810T10RB230	28	15,2	20,75	7,5	10	23	20
	74D3510T12RB300	35	18,3	22	8,5	12	30	20
	74D2311T8RB170	23	11,5	16,6	7	8	17	20
1,1	74D2811T10RB210	28	15,2	20,75	7,5	10	21	20
	74D3511T12RB270	35	18,3	22	8,5	12	27	20
	74D2813T8RB170	28	15,2	20,75	7,5	10	17	20
1,3	74D3513T12RB220	35	18,3	22	8,5	12	22	20
	74D3514T12RB210	35	18,3	22	8,5	12	21	20
1,5	74D3515T12RB190	35	18,3	22	8,5	12	19	20
1,6	74D3516T12RB180	35	18,3	22	8,5	12	18	20
1,7	74D3517T12RB170	35	18,3	22	8,5	12	17	20
1,8	74D3518T12RB160	35	18,3	22	8,5	12	16	20
1,9	74D3519T12RB150	35	18,3	22	8,5	12	15	20
2	74D3520T12RB140	35	18,3	22	8,5	12	14	20
2,1	74D3520T12RB130	35	18,3	22	8,5	12	13	20

Artikel-Nr. Designation	Ausführung Description	Qualität Grade	IN2005	IN2030	IN2505
74Z_	positive Geometrie / positive geometry				
			= P	= M	= K
			= N	= S	= H



Wälzschälrad
Skiving cutter

BP II (3972)
BP II (3972)

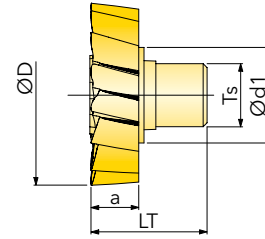

Modul Module	Artikel-Nr. Designation	D	d1	LT	a	Ts	z	α	β
0,4	74Z17004TSRA360	16,5	9,5	12,1	4,5	6	36	20	20
	74Z23004TSRA510	23	11,5	16,6	7	8	51	20	20
	74Z28004TSRA630	28	15,2	20,75	7,5	10	63	20	20
	74Z35004TSRA800	35	18,3	22	8,5	12	80	20	20
0,5	74Z17005TSRA280	16,5	9,5	12,1	4,5	6	28	20	20
	74Z23005TSRA400	23	11,5	16,6	7	8	40	20	20
	74Z28005TSRA500	28	15,2	20,75	7,5	10	50	20	20
	74Z35005TSRA630	35	18,3	22	8,5	12	63	20	20
0,6	74Z17006TSRA230	16,5	9,5	12,1	4,5	6	23	20	20
	74Z23006TSRA330	23	11,5	16,6	7	8	33	20	20
	74Z28006TSRA410	28	15,2	20,75	7,5	10	41	20	20
	74Z35006TSRA520	35	18,3	22	8,5	12	52	20	20
0,7	74Z17007TSRA190	16,5	9,5	12,1	4,5	6	19	20	20
	74Z23007TSRA280	23	11,5	16,6	7	8	28	20	20
	74Z28007TSRA350	28	15,2	20,75	7,5	10	35	20	20
	74Z35007TSRA440	35	18,3	22	8,5	12	44	20	20
0,8	74Z17008TSRA170	16,5	9,5	12,1	4,5	6	17	20	20
	74Z23008TSRA240	23	11,5	16,6	7	8	24	20	20
	74Z28008TSRA300	28	15,2	20,75	7,5	10	30	20	20
	74Z35008TSRA380	35	18,3	22	8,5	12	38	20	20
0,9	74Z23009TSRA210	23	11,5	16,6	7	8	21	20	20
	74Z28009TSRA260	28	15,2	20,75	7,5	10	26	20	20
	74Z35009TSRA340	35	18,3	22	8,5	12	34	20	20
	74Z23010TSRA190	23	11,5	16,6	7	8	19	20	20
1,0	74Z28010TSRA230	28	15,2	20,75	7,5	10	23	20	20
	74Z35010TSRA300	35	18,3	22	8,5	12	30	20	20
	74Z23011TSRA170	23	11,5	16,6	7	8	17	20	20
	74Z28011TSRA210	28	15,2	20,75	7,5	10	21	20	20
1,1	74Z35011TSRA270	35	18,3	22	8,5	12	27	20	20
	74Z28012TSRA190	28	15,2	20,75	7,5	10	19	20	20
	74Z35012TSRA250	35	18,3	22	8,5	12	25	20	20
	74Z28013TSRA170	28	15,2	20,75	7,5	10	17	20	20
1,2	74Z35013TSRA220	35	18,3	22	8,5	12	22	20	20
	74Z35014TSRA210	35	18,3	22	8,5	12	21	20	20
	74Z35015TSRA190	35	18,3	22	8,5	12	19	20	20
	74Z35016TSRA180	35	18,3	22	8,5	12	18	20	20
1,3	74Z35017TSRA170	35	18,3	22	8,5	12	17	20	20
	74D3518T12RB160	35	18,3	22	8,5	12	16	20	20
	74D3519T12RB150	35	18,3	22	8,5	12	15	20	20
	74D3520T12RB140	35	18,3	22	8,5	12	14	20	20
2,1	74D3520T12RB130	35	18,3	22	8,5	12	13	20	20

Artikel-Nr. Designation	Ausführung Description	Qualität Grade	IN2005	IN2030
74Z_	positive Geometrie / positive geometry			

● = P ● = M ● = K ● = N ● = S ○ = H



Wälzschälrad
Skiving cutter

(DIN 5480)
(DIN 5480)

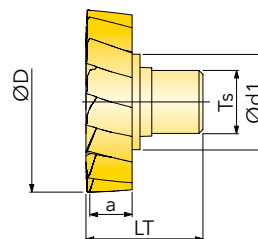

Modul Module	Artikel-Nr. Designation	D	d1	LT	a	Ts	z	α	β
0,4	74Z17004TSRB380	16,5	9,5	12,1	4,5	6	38	30	20
	74Z23004TSRB530	23	11,5	16,6	7	8	53	30	20
	74Z28004TSRB650	28	15,2	20,75	7,5	10	65	30	20
	74Z35004TSRB820	35	18,3	22	8,5	12	82	30	20
0,5	74Z17005TSRB300	16,5	9,5	12,1	4,5	6	30	30	20
	74Z23005TSRB420	23	11,5	16,6	7	8	42	30	20
	74Z28005TSRB520	28	15,2	20,75	7,5	10	52	30	20
	74Z35005TSRB650	35	18,3	22	8,5	12	65	30	20
0,6	74Z17006TSRB250	16,5	9,5	12,1	4,5	6	25	30	20
	74Z23006TSRB350	23	11,5	16,6	7	8	35	30	20
	74Z28006TSRB430	28	15,2	20,75	7,5	10	43	30	20
	74Z35006TSRB540	35	18,3	22	8,5	12	54	30	20
0,7	74Z17007TSRB210	16,5	9,5	12,1	4,5	6	21	30	20
	74Z23007TSRB300	23	11,5	16,6	7	8	30	30	20
	74Z28007TSRB370	28	15,2	20,75	7,5	10	37	30	20
	74Z35007TSRB460	35	18,3	22	8,5	12	46	30	20
0,8	74Z17008TSRB180	16,5	9,5	12,1	4,5	6	17	30	20
	74Z23008TSRB260	23	11,5	16,6	7	8	24	30	20
	74Z28008TSRB320	28	15,2	20,75	7,5	10	30	30	20
	74Z35008TSRB400	35	18,3	22	8,5	12	38	30	20
0,9	74Z17009TSRB160	16,5	9,5	12,1	4,5	6	16	30	20
	74Z23009TSRB230	23	11,5	16,6	7	8	23	30	20
	74Z28009TSRB280	28	15,2	20,75	7,5	10	28	30	20
	74Z35009TSRB350	35	18,3	22	8,5	12	35	30	20
1,0	74Z17010TSRB140	16,5	9,5	12,1	4,5	6	14	30	20
	74Z23010TSRB200	23	11,5	16,6	7	8	20	30	20
	74Z28010TSRB250	28	15,2	20,75	7,5	10	25	30	20
	74Z35010TSRB320	35	18,3	22	8,5	12	32	30	20
1,1	74Z23011TSRB190	23	11,5	16,6	7	8	19	30	20
	74Z28011TSRB230	28	15,2	20,75	7,5	10	23	30	20
	74Z35011TSRB290	35	18,3	22	8,5	12	29	30	20
	74Z23012TSRB170	23	11,5	16,6	7	8	17	30	20
1,2	74Z28012TSRB210	28	15,2	20,75	7,5	10	21	30	20
	74Z35012TSRB260	35	18,3	22	8,5	12	26	30	20
	74Z23013TSRB160	23	11,5	16,6	7	8	16	30	20
	74Z28013TSRB190	28	15,2	20,75	7,5	10	19	30	20
1,3	74Z35013TSRB240	35	18,3	22	8,5	12	24	30	20
	74Z23014TSRB140	23	11,5	16,6	7	8	14	30	20
	74Z28014TSRB180	28	15,2	20,75	7,5	10	18	30	20
	74Z35014TSRB220	35	18,3	22	8,5	12	22	30	20
1,5	74Z28015TSRB160	28	18,3	22	8,5	12	16	30	20
	74Z35015TSRB210	35	18,3	22	8,5	12	21	30	20
	74Z28016TSRB150	28	18,3	22	8,5	12	15	30	20
	74Z35016TSRB190	35	18,3	22	8,5	12	19	30	20
1,7	74Z28017TSRB140	28	18,3	22	8,5	12	14	30	20
	74Z35017TSRB180	35	18,3	22	8,5	12	18	30	20
	74Z35018TSRB170	35	18,3	22	8,5	12	17	30	20
	74Z35019TSRB160	35	18,3	22	8,5	12	16	30	20
2,0	74Z35020TSRB150	35	18,3	22	8,5	12	15	30	20
2,1	74Z35021TSRB140	35	18,3	22	8,5	12	14	30	20

Artikel-Nr. Designation	Ausführung Description	Qualität Grade	IN2005	IN2030
74Z_	positive Geometrie / positive geometry			

● = P ● = M ● = K ● = N ● = S ○ = H

Werkzeugspezifikation für technische Angebotserstellung (Einzelteilfräser) Tool Specification for technical quotation (Gasher)

Kontaktinformationen / Contact

Mitarbeiter Ingersoll / Ingersoll Contact	
Kunde / Customer	
Ansprechpartner beim Kunden / Contact Customer	
Kundennummer / Customer No.	

Auftrag / Angebot ist bereits über MySales erfasst Order/Quotation already in MySales

Ja / Yes <input type="checkbox"/>	Nein / No <input type="checkbox"/>
Auftrags-/Angebots-Nr.: Order-/Quotation-No.:	

Datum / Date: _____

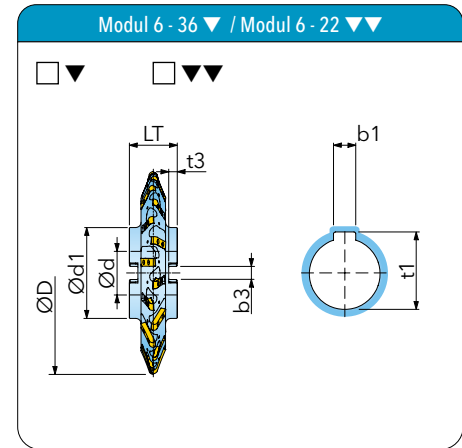
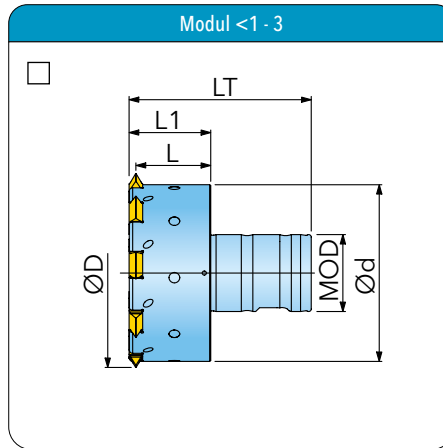
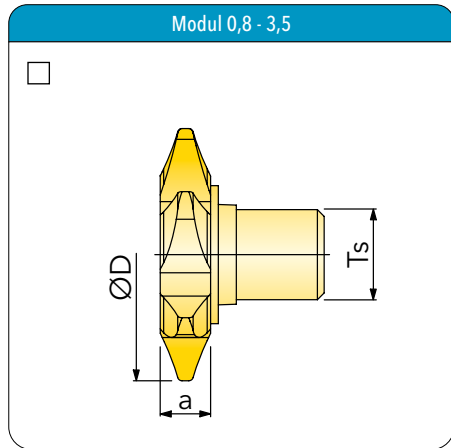

Werkzeug / Tool

Außendurchmesser / Outside diameter	D [mm]:
Aufnahmedurchmesser / Mounting diameter	Ts / d / MOD [mm]:
Bunndurchmesser / Hub diameter	d ₁ [mm]:
Werkzeugbreite / Cutter width	a / LT [mm]:
Quernut (DIN 138) / Radial keyway (DIN 138)	b ₃ [mm]:
Quernut (DIN 138) / Radial keyway (DIN 138)	t ₃ [mm]:
Längsnut (DIN 138) / Axial keyway (DIN 138)	b ₁ [mm]:
Längsnut (DIN 138) / Axial keyway (DIN 138)	t ₁ [mm]:
Kühlkanäle / Coolant channel	:

Werkstückdaten / Workpiece Data

Modul / Module	m [mm]:
Zähnezahl / No. of teeth	z:
Eingriffswinkel / Pressure angle	α [°]:
Schrägungswinkel / Helix angle	β [°]:
Profilverschiebungsfaktor / Addendum modification coefficient	x:
Kopfkreisdurchmesser / Tip diameter	d _a [mm]:
Fußkreisdurchmesser / Root diameter	d _f [mm]:
Zahnfußrundungsradius / Root radius	ρ _{fp} [mm]:
Diametrales Zweikugelmaß / Dimension over balls	M _d [mm]
Oberes diametrales Zweikugelmaß / Max. dimension over balls	M _{dmax} [mm]:
Unteres diametrales Zweikugelmaß / Min. dimension over balls	M _{dmin} [mm]:
Messkugeldurchmesser / Ball diameter	D _M [mm]:
Zahnweite über k Messzähne / Base tangent length over k meas. teeth	W _k [mm]:
Obere Zahnweite / Max. base tangent length	W _{kmax} [mm]:
Untere Zahnweite / Min. base tangent length	W _{kmin} [mm]:
Messzähnezahl / No. of measuring teeth	k:
Vorfräsen/Schlichten / Roughing/Finishing	:
Aufmaß zum Fertigprofil / Stock for finishing	[mm]:
Verzahnungsqualität / Gear quality	[DIN 3962]:
Bezugsprofil / Basic rack profile	:

Bemerkung / Remark	
--------------------	--

Werkzeugspezifikation für technische Angebotserstellung (Wälzfräser) Tool Specification for Technical quotation (Hob cutter)

Kontaktinformationen / Contact

Mitarbeiter Ingersoll / Ingersoll Contact	
Kunde / Customer	
Ansprechpartner beim Kunden / Contact Customer	
Kundennummer / Customer No.	

Auftrag / Angebot ist bereits über MySales erfasst
 Order/Quotation already in MySales

Ja / Yes Nein / No

Auftrags-/Angebots-Nr.:
 Order-/Quotation-No.:

Datum / Date: _____

Werkzeug / Tool

Werkzeuglänge / Tool length	LT [mm]:	
Nutzlänge / Usable length	L [mm]:	
Nut (axial/radial) / Keyway (axial/radial)	a / r:	
Nutbreite / Keyway width	b1 / b3 [mm]:	
Nuttiefe / Keyway depth	t1 / t3 [mm]:	
Modul / Module	m [mm]:	
Außendurchmesser / Outside diameter	D [mm]:	
Bohrungsdurchmesser / Bore diameter	d [mm]:	
Bunddurchmesser / Hub diameter	d1 [mm]:	
Güteklasse gemäß / Quality class acc. to	[DIN 3968]:	
Spiralrichtung / Spiral direction	LH/RH:	
Gangzahl / No. of starts / No. of starts	:	

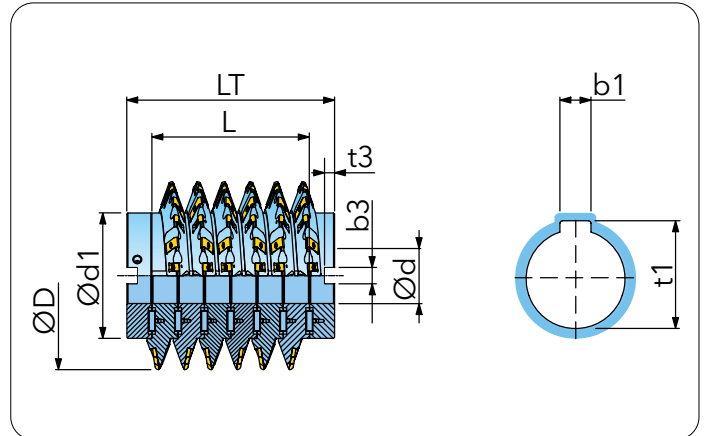

Schlichtfräserprofil / Profile of Finishing Hob

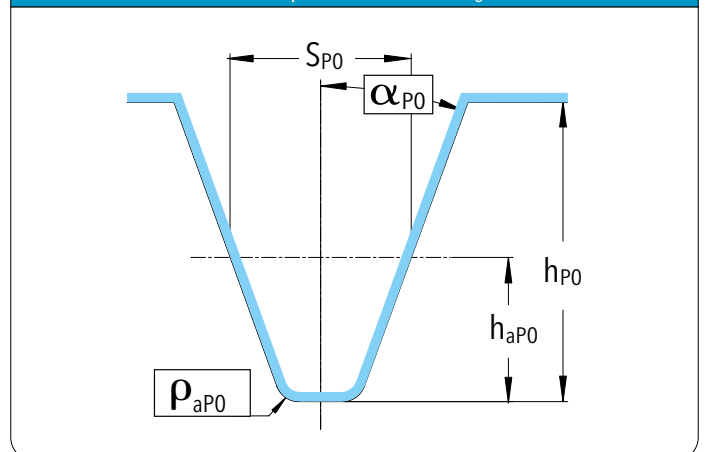

Werkzeugprofildaten / Tool Profile Data

Kopfhöhe / Addendum	haP0 [mm]:	
Zahndicke / Tooth thickness	Sp0 [mm]:	
Profilhöhe / Tooth depth	hP0 [mm]:	
Eingriffswinkel / Pressure angle	αp0 [°]:	
Kopfradius / Tip radius	paP0 [mm]:	
Protuberanzbetrag / Protuberance amount	prP0 [mm]:	
Protuberanzwinkel / Protuberance angle	αprP0 [°]:	

Schruppfräserprofil mit Protuberanz / Profile of Roughing Hob with protuberance

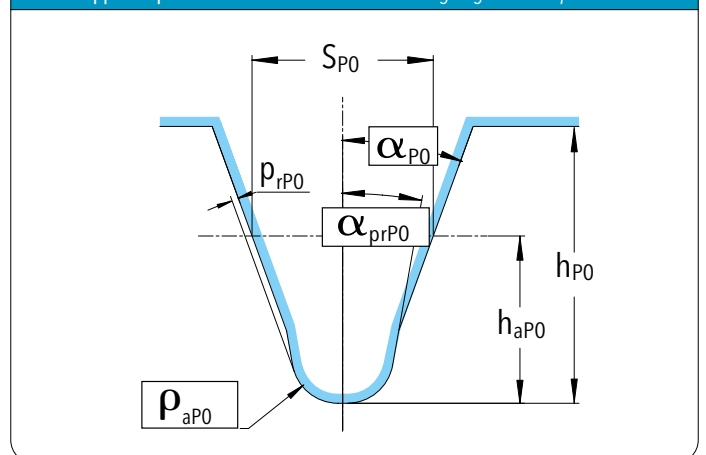

Bemerkung / Remark	
--------------------	--

Werkzeugspezifikation für technische Angebotserstellung (Schneidrad / Stoßrad) Tool Specification for technical quotation (Gasher)

Kontaktinformationen / Contact	
Mitarbeiter Ingersoll / Ingersoll Contact	
Kunde / Customer	
Ansprechpartner beim Kunden / Contact Customer	
Kundennummer / Customer No.	

Auftrag / Angebot ist bereits über MySales erfasst Order/Quotation already in MySales	
Ja / Yes <input type="checkbox"/>	Nein / No <input type="checkbox"/>
Auftrags-/Angebots-Nr.: Order-/Quotation-No.:	
Datum / Date: _____	

Modul / Module 0,4-2,1

Vollhartmetall / Solid Carbide

Modul / Module 3-18

Wendeschnidplatten-Typ / Indexable inserts type

Werkzeug / Tool	
Außendurchmesser / Outside diameter	D [mm]:
Aufnahmedurchmesser / Adaption diameter	Ts / d [mm]:
Bunddurchmesser / Hub diameter	d ₁ [mm]:
Werkzeugbreite / Cutter width	a / LT [mm]:
Nutbreite / Key way width	b [mm]:
Nuttiefe / Key way depth	t [mm]:
Modul / Module	m [mm]:
Zähnezahl / No. of teeth	z ₀ :
Teilkreisdurchmesser / Pitch diameter	d ₀ [mm]:
Kopfhöhe / Addendum	h _{aPO} [mm]:
Fußhöhe / Dedendum	h _{fPO} [mm]:
Profilverschiebung / Addendum modification	x ₀ • m [mm]:
Eingriffswinkel / Pressure angle	α ₀ [°]:
Schrägungswinkel / Helix angle	β ₀ [°]:
Flankenrichtung / Flank direction	L / R:
Kopfradius / Tip radius	ρ _{aPO} [mm]:
Zahnweitenmaß / Base tangent length	W _{k0} [mm]:
Messzähnezahl / No. of measuring teeth	k ₀ :

Werkstückdaten / Workpiece Data	
Modul / Module	m [mm]:
Zähnezahl (+AVZ / -IVZ) / No. of teeth (+EXT / -INT)	z:
Eingriffswinkel / Pressure angle	α _{po} [°]:
Schrägungswinkel / Helix angle	β [°]:
Flankenrichtung / Flank direction	L / R:
Profilverschiebungsfaktor / Addendum modification coefficient	x:
Kopfkreisdurchmesser / Tip diameter	d _a [mm]:
Fußkreisdurchmesser / Root diameter	d _f [mm]:
Diametrales Zweikugelmaß / Dimension over balls	M _d [mm]:
Oberes diametrales Zweikugelmaß / Max. dimension over balls	M _{dmax} [mm]:
Unteres diametrales Zweikugelmaß / Min. dimension over balls	M _{dmin} [mm]:
Messkugeldurchmesser / Ball diameter	D _M [mm]:
Zahnweite über k Messzähne / Base tangent length over k meas. teeth	W _k [mm]:
Obere Zahnweite / Max. base tangent length	W _{kmax} [mm]:
Untere Zahnweite / Min. base tangent length	W _{kmin} [mm]:
Messzähnezahl / No. of measuring teeth	k:
Aufmaß zum Fertigprofil / Stock for finishing	[mm]:
Verzahnungsqualität / Gear quality	:
Bezugsprofil / Basic rack profile	:

Bemerkung / Remark	
--------------------	--

Kontaktinformationen / Contact	
Mitarbeiter Ingersoll / Ingersoll Contact	
Kunde / Customer	
Ansprechpartner beim Kunden / Contact Customer	
Kundennummer / Customer No.	

Auftrag / Angebot ist bereits über MySales erfasst Order/Quotation already in MySales	
Ja / Yes <input type="checkbox"/>	Nein / No <input type="checkbox"/>
Auftrags-/Angebots-Nr.: Order-/Quotation-No.:	
Datum / Date: _____	

Maschinenhersteller / Typ Machine tool builder / Type		Leistung (kW) / Power (kW)	
Drehzahl n-1 / Revolution speed (rpm)	Spindel / Spindle		Tisch / Table
Innere Kühlmittelzufuhr / Internal coolant			
HSK-T	ISO 12164-3	100 <input type="checkbox"/>	80 <input type="checkbox"/> 63 <input type="checkbox"/> 50 <input type="checkbox"/>
Polygon	ISO 26623-1	C8X <input type="checkbox"/>	C8 <input type="checkbox"/> C6 <input type="checkbox"/> C5 <input type="checkbox"/>
Sonderaufnahme / Special adaption			
Werkstückstoff / Workpiece material			

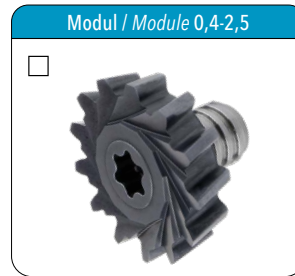

Werkstückdaten / Workpiece Data	
Modul / Module	m [mm]:
Verzahnungsqualität / Gear quality	:
Zähnezahl (+AVZ / -IVZ) / No. of teeth (+EXG / -ING)	z:
Eingriffswinkel / Pressure angle	α [°]:
Schrägungswinkel / Helix angle	β [°]:
Flankenrichtung / Flank direction	L / R:
Profilverschiebungsfaktor / Addendum modification coefficient	x:
Kopfkreisdurchmesser / Tip diameter	d_a [mm]:
Fußkreisdurchmesser / Root diameter	d_f [mm]:
Zahnfußradius / Root radius	ρ_{fp} [mm]:
Fußformkreisdurchmesser / Root form diameter	d_{ff} [mm]:
Diametrales Zweikugelmaß / Dimension over balls	M_d [mm]:
Oberes diametrales Zweikugelmaß / Max. dimension over balls	M_{dmax} [mm]:
Unteres diametrales Zweikugelmaß / Min. dimension over balls	M_{dmin} [mm]:
Messkugeldurchmesser / Ball diameter	D_M [mm]:
Zahnweite über k Messzähne / Base tangent length over k meas. teeth	W_k [mm]:
Obere Zahnweite über k-Zähne / Max. base tangent length	W_{kmax} [mm]:
Untere Zahnweite über k-Zähne / Min. base tangent length	W_{kmin} [mm]:
Messzähnezahl / No. of measuring teeth	k:
Aufmaß zum Fertigprofil / Stock for finishing	[mm]:
Bezugsprofil / Basic rack profile	:

Kollisionsmaße Bauteil / Workpiece collision dimensions			
Aussenverzahnung / External gear			
<input type="checkbox"/>			
Innenverzahnung / Internal gear			
<input type="checkbox"/>			
D1		mm	
D2		mm	
L1		mm	
L2		mm	
b		mm	

Zahnformmodifikation / Gear tooth modification		
Protuberanz / Protuberance	Nein / No <input type="checkbox"/>	Ja / Yes <input type="checkbox"/>

Kopfrücknahme / Tip relief	Nein / No <input type="checkbox"/>	Ja / Yes <input type="checkbox"/>

Bemerkung / Remark	

GEGENÜBERSTELLUNG: TEILUNG - MODUL - DP - CP
COMPARISON: PITCH - MODULE - DIAMETRAL PITCH - CIRCULAR PITCH

Teilung Pitch	Modul Module	DP	CP
0,31416	0,10	-	-
0,34558	0,11	-	-
0,37699	0,12	-	-
0,39898	-	200	-
0,43982	0,14	-	-
0,44331	-	180	-
0,45598	-	175	-
0,49873	-	160	-
0,50265	0,16	-	-
0,53198	-	150	-
0,56549	0,18	-	-
0,62831	0,20	-	-
0,62832	-	127	-
0,66497	-	120	-
0,69115	0,22	-	-
0,75997	-	105	-
0,78540	0,25	-	-
0,79796	-	100	-
0,83121	-	96	-
0,87965	0,28	-	-
0,90678	-	88	-
0,94248	0,30	-	-
0,99746	-	80	-
1,09557	0,35	-	-
1,10828	-	72	-
1,24682	-	64	-
1,25664	0,40	-	-
1,32994	-	60	-
1,41372	0,45	-	-
1,57080	0,50	-	-
1,58750	-	-	1/16
1,59593	-	50	-
1,66243	-	48	-
1,72788	0,55	-	-
1,73471	-	46	-
1,81356	-	44	-
1,88496	0,60	-	-
1,89992	-	42	-
1,99491	-	40	-
2,04204	0,65	-	-
2,09991	-	38	-
2,19911	0,70	-	-
2,21657	-	36	-
2,34695	-	34	-
2,35619	0,75	-	-
2,49364	-	32	-
2,51327	0,80	-	-
2,65988	-	30	-
2,67035	0,85	-	-
2,82743	0,90	-	-

Teilung Pitch	Modul Module	DP	CP
2,84987	-	28	-
2,98451	0,95	-	-
3,06909	-	26	-
3,14159	1	-	-
3,17500	-	-	1/8
3,32485	-	24	-
3,62711	-	22	-
3,92699	1,25	-	-
3,98982	-	20	-
4,43314	-	18	-
4,71239	1,5	-	-
4,76250	-	-	3/16
4,98728	-	16	-
5,49779	1,75	-	-
5,69975	-	14	-
6,28319	2	-	-
6,35000	-	-	1/4
6,64970	-	12	-
7,06858	2,25	-	-
7,85398	2,5	-	-
7,93750	-	-	5/16
7,97965	-	10	-
8,63938	2,75	-	-
8,86627	-	9	-
9,42478	3	-	-
9,52500	-	-	3/8
9,97456	-	8	-
10,21018	3,25	-	-
10,99557	3,5	-	-
11,11250	-	-	7/16
11,39949	-	7	-
11,78097	3,75	-	-
12,56637	4	-	-
12,70000	-	-	1/2
13,29941	-	6	-
14,13717	4,5	-	-
14,28750	-	-	9/16
14,50845	-	-	5/12
15,70796	5	-	-
15,87500	-	-	5/8
15,95930	-	5	-
17,27876	5,5	-	-
17,46250	-	-	11/16
17,73255	-	4 1/2	-
18,84956	6	-	-
19,05000	-	-	3/4
19,94911	-	4	-
20,42035	6,5	-	-
20,63750	-	-	13/16
21,99115	7	-	-

Teilung Pitch	Modul Module	DP	CP
22,22500	-	-	7/8
22,79899	-	3 1/2	-
23,81250	-	-	15/16
25,13274	8	-	-
25,40000	-	-	1
26,59892	-	3	-
26,98750	-	-	11/16
28,27433	9	-	-
28,57500	-	-	11/8
29,01689	-	2 3/4	-
30,16250	-	-	13/16
31,41593	10	-	-
31,75000	-	-	11/4
31,91858	-	2 1/2	-
33,33750	-	-	15/16
34,55752	11	-	-
34,92500	-	-	13/8
35,46509	-	2 1/4	-
36,51250	-	-	17/16
37,69911	12	-	-
38,10000	-	-	11/2
39,89823	-	2	-
41,27500	-	-	15/8
43,98230	14	-	-
44,45000	-	-	13/4
45,59797	-	13/4	-
47,62500	-	-	17/8
50,26548	16	-	-
50,80000	-	-	2
53,19764	-	11/2	-
56,54867	18	-	-
62,83185	20	-	-
63,83716	-	11/4	-
69,11504	22	-	-
75,39822	24	-	-
78,53982	25	-	-
79,79645	-	1	-
81,68141	26	-	-
87,96459	28	-	-
91,19595	-	7/8	-
94,24778	30	-	-
100,53096	32	-	-
106,39527	-	3/4	-
109,95574	35	-	-
113,09734	36	-	-
125,66371	40	-	-
127,67432	-	5/8	-
141,37167	45	-	-
157,07963	50	-	-
159,59290	-	1/2	-

Modul / Module

$$m = \frac{25,4}{DP}$$

$$m = 8,08507111 \times CP$$

Diametral Pitch

$$DP = \frac{3,14159265}{CP}$$

$$DP = \frac{25,4}{m}$$

Circular Pitch

$$CP = \frac{3,14159265}{DP}$$

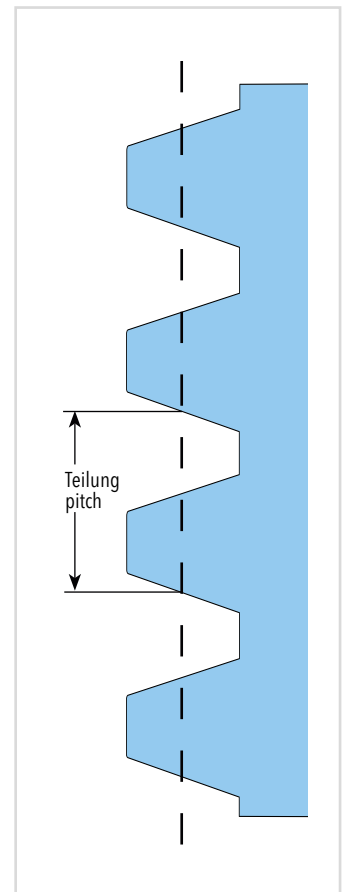
$$CP = \frac{m}{8,08507111}$$

INSPEKTION & WERKZEUG-INSTANDSETZUNGSSERVICE INSPECTION & TOOL MAINTENANCE SERVICE

Bei der Anschaffung Ihres Verzahnungswerkzeuges haben Sie sich bereits für die Qualität und den Service unserer Produkte entschieden. Diese Entscheidung sollte auch auf die Wartung Ihrer Verzahnungswerkzeuge ausgeweitet werden. Trotz sorgfältigem Einsatz der Werkzeuge kommt es hin und wieder, aus unterschiedlichen Gründen, zu Werkzeugbruch. Ingersoll bietet Ihnen den Service, die Reparatur der Werkzeuge sorgfältig und kostengünstig durchzuführen. Innerhalb kürzester Zeit werden die Werkzeuge bezüglich des Beschädigungsgrades inspiziert. Im Anschluss daran teilen wir Ihnen mit, ob die Instandsetzung wirtschaftlich durchzuführen ist. Die fachgerechte Reparatur der Werkzeuge erfolgt, je nach Arbeitsaufwand, innerhalb von fünf Arbeitstagen.

Wir garantieren Ihnen, dass die Reparatur in gewohnter Ingersoll-Qualität termingerecht durchgeführt wird. Die Qualität eines Werkzeuges beeinflusst wesentlich die Wirtschaftlichkeit Ihrer Fertigung. Gehen Sie auch bei der Instandsetzung keine Kompromisse ein. Nur so stellen Sie die Wirtschaftlichkeit Ihrer Fertigung sicher.

Sie können sich auf INGERSOLL verlassen.

With the purchase of the gear milling tool, you have already made your decision for the quality and service of our products. This decision should also be extended to the maintenance of your gear milling tool.

Despite careful application of the tool, every now and then the tool can be damaged for various reasons. Ingersoll offers the service of cost-efficient and careful repair and maintenance. The tool will be carefully inspected within a short period of time to determine the extent of damage. Subsequently, you will be informed as to whether the repair of the tool would be profitable. The professional repair of the tools will be carried out within five days, depending on the amount of labour involved.

We guarantee that the repair will be carried out on time, with the usual Ingersoll quality. The quality of a tool has greatly influence on the efficiency of its production. Make no compromises where quality of maintenance is concerned; only then can you be sure of the superior efficiency of your production.

You can rely on INGERSOLL.

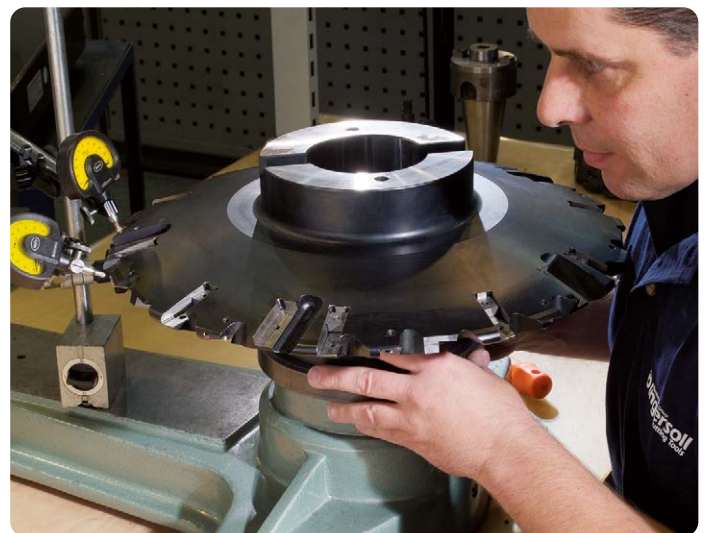
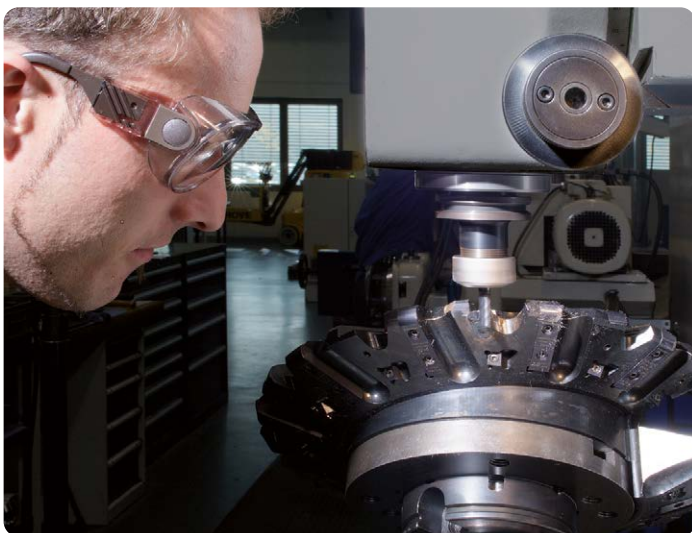
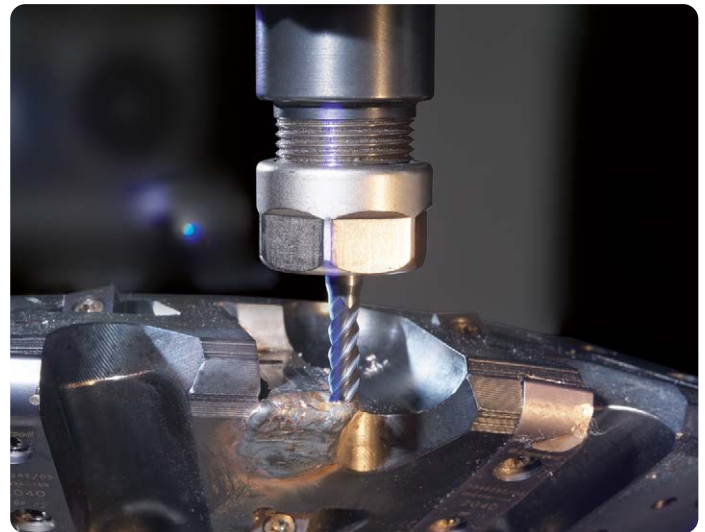

Ingersoll Cutting Tools

Marketing- & Technologie-Standorte

Deutschland

Ingersoll Werkzeuge GmbH

Hauptsitz:

Kalteiche-Ring 21-25
35708 Haiger, Germany
Telefon: +49 (0)2773-742-0
Telefax: +49 (0)2773-742-812
E-Mail: info@ingersoll-imc.de
Internet: www.ingersoll-imc.de

Niederlassung Süd:

Florianstraße 13-17
71665 Vaihingen-Horrheim, Germany
Telefon: +49 (0)7042-8316-0
Telefax: +49 (0)7042-8316-26
E-Mail: horrheim@ingersoll-imc.de

Niederlassung Wulften:

Steinstraße 11
37199 Wulften
Telefon: +49 (0)5556-99 55 98-0
Telefax: +49 (0)5556-99 55 98-25
E-Mail: wulften@ingersoll-imc.de

USA

Ingersoll Cutting Tools

845 S. Lyford Road
Rockford, Illinois 61108-2749, USA
Telefon: +1-815-387-6600
Telefax: +1-815-387-6968
E-Mail: info@ingersoll-imc.com
Internet: www.ingersoll-imc.com

France

Ingersoll France

22, rue Albert Einstein
F-77420 CHAMPS-sur-MARNE
Telefon: +33 (0) 1 64 68 45 36
Telefax: +33 (0) 1 64 68 45 24
E-Mail: info@ingersoll-imc.fr
Internet: www.ingersoll-imc.fr

