

Insert Widths:

- TMIS8-0.50-0.00 - 0.5mm (.0197")
- TMIS8-1.00-0.00 - 1.0mm (.0394")
- TMIS8-1.50-0.05 - 1.5mm (.0591")
- TMIS8-2.00-0.10 - 2.0mm (.0787")

Max. Cutting Depth:
Up to .059"

Grade:
TT4430

- PVD-AlTiCrN coated
- Ideal for small parts machining
- Steel, stainless steel, titanium

ID Grooving Bars:
.500" Diameter
Carbide and Steel
2xD, 3xD & 4xD

Miniature Size Inserts and Holders for Shallow Internal Grooving

Ingersoll is pleased to introduce a new internal grooving system for bores as small as .394" (10mm). This system features a unique, stable and flexible insert clamping system along with a new TT4430 grade specifically developed for small parts manufacturing.

Features & Benefits:

- Suitable for small diameter internal grooves with minimum bore diameter down to .394" (10mm)
- Robust, 3-point contact design with screw clamping prevents vibration and generates an excellent surface finish
- Neutral holder design allows inserts to be mounted in 4 different ways, eliminating the need for handed tools and allowing either CW or CCW spindle rotation
- Internal coolant supply for longer tool life
- Steel and carbide shank options
- Economical alternative to solid carbide grooving tools
- Inserts feature new PVD-coated grade TT4430 and a sharp cutting edge





MINIFLEX™ FEATURES

It's not uncommon to experience vibration during small diameter grooving operations due to long length-to-diameter ratios. This results in a poor surface finish and shortened tool life.

To solve this problem, Ingersoll has introduced MiniFlex, a small diameter internal grooving solution with a robust 3-point contact design and top screw mounting system. This unique clamping design stabilizes the insert connection, and also ensures the repeatability accuracy of the insert position in the holder, resulting in excellent surface finish and durability.

The neutral holder is designed such that the insert can be mounted in four different ways, eliminating a need for handed tools, and allowing for spindle rotation in either direction. This reduces inventory requirements and provides flexibility during set-ups.

MiniFlex is optimally suited for internal grooving and turning from a bore diameter down to $\varnothing .394$ " (10mm). Initial cutting widths range from .0197" ~ .0787" (0.5mm~2.0mm).

A new grade, TT4430, has been developed specifically for small parts machining. This PVD-AlTiCrN coated grade features a tough, submicron substrate that provides anti-chipping, long tool life and very reliable performance. The sharp cutting edge is ideal for machining small parts in a variety of materials including steel, stainless steel and titanium, and is ideal for minimizing burrs and build-up.

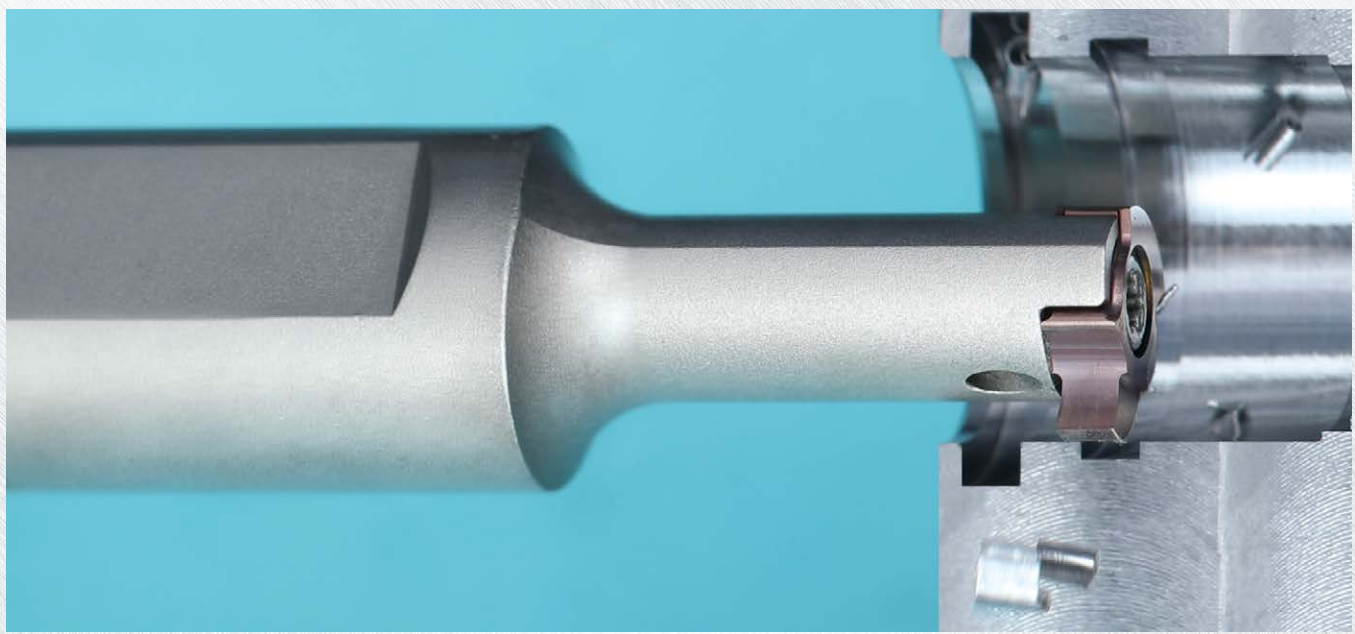

MINIFLEX™

Machining Depth by Shank Material

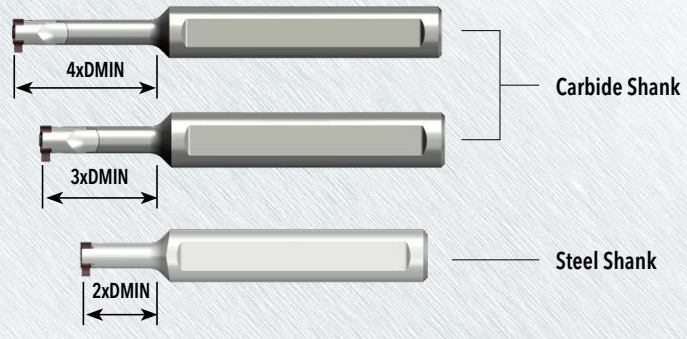

Coolant Through Design

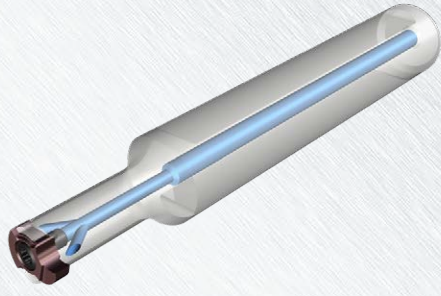

Robust 3-Point Contact and Screw Clamping



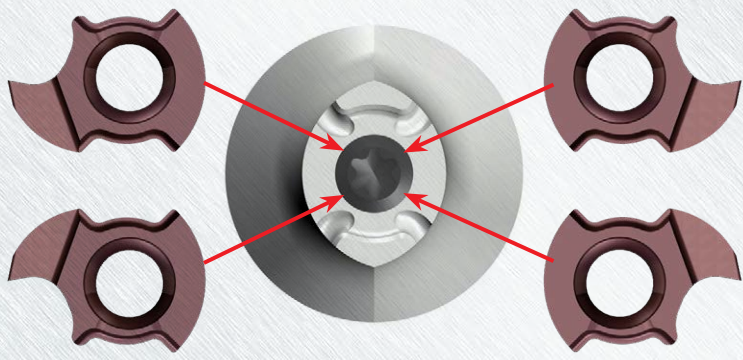

Insert can be mounted onto neutral holders in 4 ways, making it very flexible for any set-up.



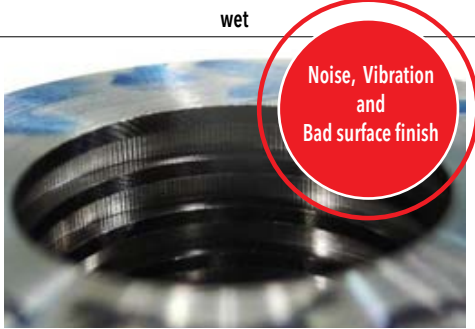

MINIFLEX™ CASE STUDY 1

| | | Competitor | Ingersoll |
|------------------|-----------|---|--|
| Material | | AISI 1045 | |
| Operation | | Internal grooving (Ø.787" (20mm)) | |
| Insert | | Single-ended insert | TMIS 8-2.00-0.10 TT4430 |
| Holder | | Ø12 internal grooving holder | TMIHN 12-16-8 |
| Cutting speed | V (sfm) | 330 | 330 |
| Feed rate | f (ipr) | .0004, .0008, .0012 | .0004, .0008, .0012 |
| Depth of cut | ap (inch) | .060 | .060 |
| Coolant | | wet | wet |
| Machined surface | |  |  |

MINIFLEX™ CASE STUDY 1

| | | Competitor | Ingersoll |
|------------------------|-----------|------------------------------|-------------------------|
| Material | | AISI 1045 | |
| Operation | | Internal grooving | |
| Insert | | Single-ended insert | TMIS 8-2.00-0.10 TT4430 |
| Holder | | Ø12 internal grooving holder | TMIHN 12-16-8 |
| Cutting speed | V (sfm) | 328 | 328 |
| Feed rate | f (ipr) | .0016 | .0016 |
| Depth of cut | ap (inch) | .040 | .040 |
| Coolant | | wet | wet |
| Tool life (pcs/corner) | | 200 | 300 |

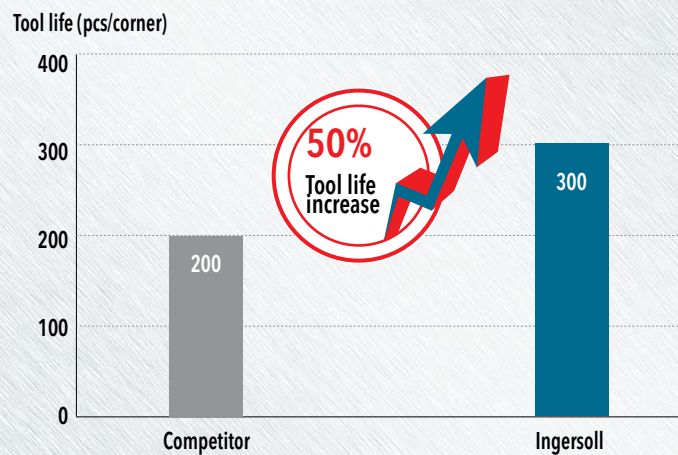



MINIFLEX™ SERIES TMIHN

INTERNAL GROOVING HOLDER WITH COOLANT HOLES

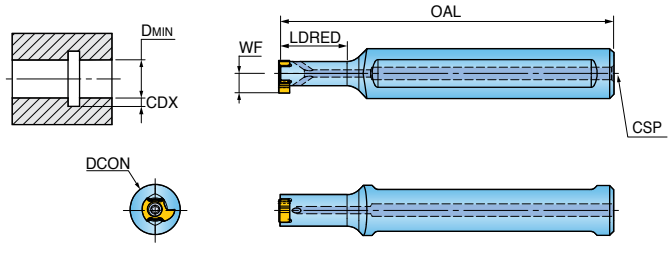

| Designation | Dimension (inch) | | | | | Insert |
|------------------------|---------------------|-------------------------|---------------------|--------------------------------|--------------------|--------|
| | DCON Shank Diameter | DMin Min. Bore Diameter | WF Functional Width | LDRED Reduced Body Dia. Length | OAL Overall Length | |
| TMIHN 12.7-16-8 | .500 | .394 | .185 | .63 | 3.0 | TMIS 8 |

CDX: Refer to insert dimension

Spare Parts

| Designation | Screw | Wrench | |
|-------------|--------------|---|---|
| | TMIHN |  TS 220521/HG |  T7 |



MINIFLEX™ SERIES TMIHN-C

INTERNAL GROOVING CARBIDE HOLDERS WITH COOLANT HOLES

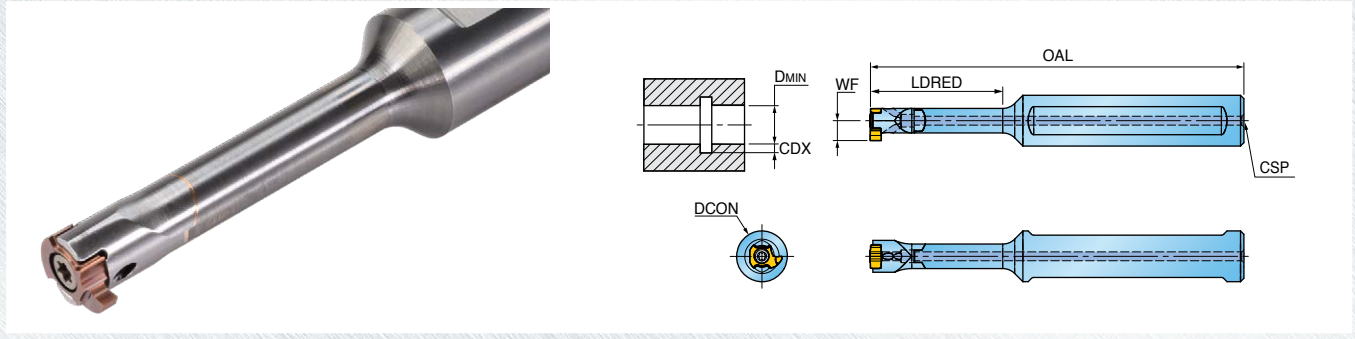

| Designation | Dimension (inch) | | | | | Insert |
|------------------|---------------------|-------------------------|---------------------|--------------------------------|--------------------|--------|
| | DCON Shank Diameter | DMin Min. Bore Diameter | WF Functional Width | LDRED Reduced Body Dia. Length | OAL Overall Length | |
| TMIHN 12.7C-24-8 | .500 | .394 | .185 | .94 | 3.6 | TMIS 8 |
| TMIHN 12.7C-32-8 | .500 | .394 | .185 | 1.26 | 4.0 | |

CDX: Refer to insert dimension

Spare Parts

| Designation | Screw | Wrench | |
|-------------|---------|--------------|----|
| | TMIHN-C | TS 220521/HG | T7 |



MINIFLEX™ SERIES TMIS 8

PRECISE INSERTS FOR INTERNAL SHALLOW GROOVING

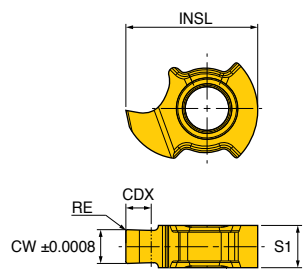
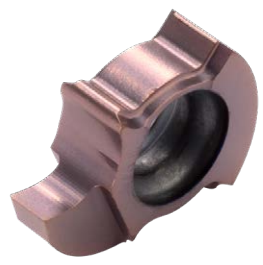

| Designation | Feed (ipr) | Dimension (inch) | | | | | Grade |
|------------------|-------------|------------------|------------------|------------------------|--------------------|---------------------|--------|
| | | CW Cutting Width | RE Corner Radius | CDX Cutting Depth Max. | INSL Insert Length | S1 Insert Thickness | TT4430 |
| TMIS 8-0.50-0.00 | .0004-.0012 | .0197 | .000 | .028 | .307 | .098 | • |
| TMIS 8-1.00-0.00 | .0004-.0012 | .0394 | .000 | .059 | .307 | .098 | • |
| TMIS 8-1.50-0.05 | .0004-.0012 | .0591 | .002 | .059 | .307 | .098 | • |
| TMIS 8-2.00-0.10 | .0004-.0012 | .0787 | .004 | .059 | .307 | .098 | • |

•: Standard items



COMPLETE METALWORKING SOLUTIONS

(800) 991-4225

www.ahbinc.com

ISO Certified

customerservice@ahbinc.com