



Cutter Series:
8G5A, 8G6A

Diameters:
2.000"-4.000"

Insert Series:
LGM324R001-ML
LGX324R001-M

Materials:
Steel, Stainless Steel, Hi-Temps,
Titanium

Grades:
IN4005/IN2505/IN4030
IN2530/IN4035/IN2535

Max. Depth of Cut:
.058"



Hi Feed Facemill Family With Strong Tangential Inserts and Reliable Dovetailed Insert Seating

Features & Benefits:

- Unique diamond shaped inserts provide the highest ramping feed-rates at the steepest ramping angles.
- Thick tangential inserts give maximum reinforcement to the cutting edge and cutter longevity.
- Large insert seating areas are dovetailed to stabilize and support the insert under the most aggressive conditions.
- Inserts offered in both pressed and ground profiles for economical performance across all material types.

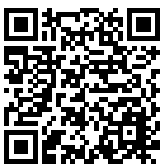



NUMAX^{HF}™ SERIES 8G5A, 8G6A

HIGH FEED FACE MILL

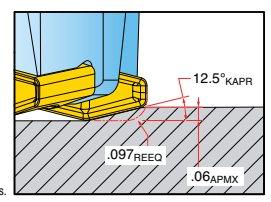
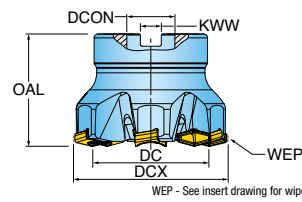

WEP - See insert drawing for wiper options.

Part Number	DCX Cutting Dia. Max.	DC Cutting Dia.	OAL Overall Length	ZEFF Effective Teeth	REEQ Program Radius Equivalent	KAPR Cutting Edge Angle	DCON Bore Dia.	KWW Keyway	RMPX Ramp Angle Max.
8G5A-02R01	2.000	1.408	1.750	5	0.097	12.7	0.750	0.31	3.00
8G6A-02R01	2.000	1.408	1.750	4	0.097	12.7	0.750	0.31	3.00
8G6A-02R03	2.500	1.901	1.750	5	0.097	12.6	0.750	0.31	2.10
8G6A-02R02	2.500	1.902	1.750	5	0.097	12.6	1.000	0.38	2.10
8G5A-03R01	3.000	2.399	1.750	7	0.097	12.7	1.000	0.38	1.60
8G5A-03R02	3.000	2.399	1.750	7	0.097	12.5	1.250	0.50	1.60
8G5A-04R01	4.000	3.398	2.500	9	0.097	12.5	1.500	0.63	1.10
8G6A-04R01	4.000	3.398	2.500	7	0.097	12.5	1.500	0.63	1.10

*Insert screw tightening torque: 30-35 in*lb.



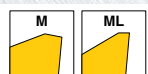



NUMAX^{HF}™ INSERTS



Part Number	Application	RE Corner Radius	BS Wiper Length	INSL Insert Length	W1 Insert Width	S1 Thickness	NOI Number of Indexes	IH Insert Hand	Grade	IN4005	IN2505	IN4030	IN2530	IN4035	IN2535
LGX324R001-M	Hi-Feed, Heavy-Duty	0.040	0.060	0.610	0.373	0.256	4	Right		•	•	•	•		
LGM324R001-ML	Hi-Feed, Heavy-Duty Keen Edge	0.040	0.060	0.610	0.373	0.256	4	Right		•	•	•	•	•	•



NUMAX^{HF}™ HARDWARE

							
	Screw	Driver Handle	Driver Bit	Retention Bolt	Torque Driver Handle	Preset Torque Bit	Torque Driver Bit
8G5A-02R01	SM40-123-H0	DS-A00T	DS-T156B	SB-04-15	DS-A00-.25T	DT-35-.25	DS-T15B
8G6A-02R01	SM40-123-H0	DS-A00T	DS-T156B	SB-04-15	DS-A00-.25T	DT-35-.25	DS-T15B
8G6A-02R03	SM40-123-H0	DS-A00T	DS-T156B	SD-06-47	DS-A00-.25T	DT-35-.25	DS-T15B
8G6A-02R02	SM40-123-H0	DS-A00T	DS-T156B	SD-08-47	DS-A00-.25T	DT-35-.25	DS-T15B
8G5A-03R01	SM40-123-H0	DS-A00T	DS-T156B	SD-08-47	DS-A00-.25T	DT-35-.25	DS-T15B
8G5A-03R02	SM40-123-H0	DS-A00T	DS-T156B	SD-10-47	DS-A00-.25T	DT-35-.25	DS-T15B
8G5A-04R01	SM40-123-H0	DS-A00T	DS-T156B	SD-12-82	DS-A00-.25T	DT-35-.25	DS-T15B
8G6A-04R01	SM40-123-H0	DS-A00T	DS-T156B	SD-12-82	DS-A00-.25T	DT-35-.25	DS-T15B

NUMAX^{HF}™ STRAIGHT RAMPING

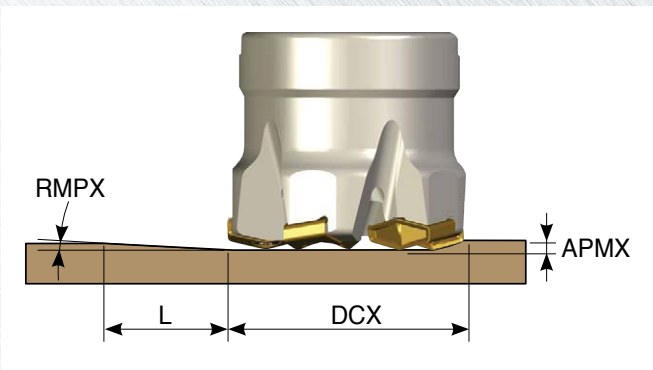

DCX Cutter Diameter	RMPX Ramp Angle Max.	L Ramp Length Min.	APMX Depth of Cut Max.
2.000	3.00	1.106	0.058
2.500	2.10	1.581	0.058
3.000	1.60	2.076	0.058
4.000	1.10	3.020	0.058

L in this table is the length the cutter travels to reach the max. depth of cut (.058") while traveling at the max ramp angle listed for the cutter.

NUMAX^{HF}™ HELICAL RAMPING

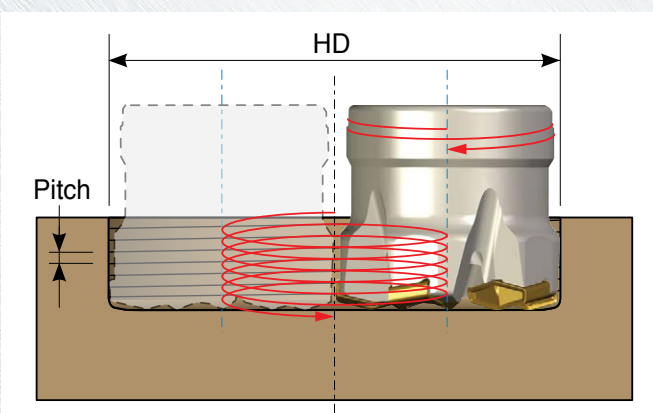

DCX Cutter Diameter	HD Hole Dia. Min.	HD Hole Dia. Max.	HD Hole Dia. Max. w/o Cusp	Max Pitch Per Revolution
2.000	2.898	4.000	3.408	0.058
2.500	3.875	5.000	4.401	0.058
3.000	4.864	6.000	5.399	0.058
4.000	6.860	8.000	7.398	0.058

Pitch:
The max. pitch is determined to not exceed the max. depth of cut (APMX) and to not exceed the max. ramp angle (RMPX).



NUMAX^{HF}™ OPERATING GUIDELINES

ISO	Materials			V _c Cutting Speed SFM	f _z Feed/ Tooth (inch)	H _{ex} Max. Chip Thickness (inch)	Harder <-----> Tougher						Coolant	Geometry	
	Mat'l Group #VDI 3323	Type	Examples				IN4005	IN2505	IN4030	IN2530	IN4035	IN2535		M	ML
P	1 thru 5	Non-alloy Steel	1018, A36, 1045, A572, 1070	400-850	.018-.063	.004-.014	2	1	4	3			NO	2	1
	6 thru 9	Low-alloy Steel	4140, 4340, P20, 8620, 300M	350-500	.018-.054	.004-.012	2	1	4	3			NO	2	1
	10, 11	High-alloy Steel	H13, A2, D2, M2, T1	250-500	.018-.050	.004-.011	2	1	4	3			NO	1	2
M	12 thru 13	"Stainless Steel (Ferritic & Martensitic)"	410, 416, 440	350-550	.014-.050	.003-.011			4	3	2	1	YES	2	1
	14	Stainless Steel (Austenitic)	"303, 304, 316, 15-5, 17-4"	300-500	.014-.050	.003-.011			4	3	2	1	YES	2	1
K	15 thru 16	Gray Cast Iron	CLS. 20, 30, 45	500-700	.018-.063	.004-.014	1	2	3	4			NO	1	2
	17 thru 20	Nodular Cast Iron	"60-40-18, 100-70-03"	400-650	.018-.063	.004-.014	2	1	4	3			NO	1	2
S	31 thru 35	High-Temp Alloys	Inconel, Hastelloy, Nimonic, Monel	60-130	.014-.027	.003-.006			4	3	2	1	YES	2	1
	36 thru 37	Titanium Alloys	6AL-4V, 5Al-5Mo-5V-3Cr	65-150	.014-.032	.003-.007			4	3	2	1	YES	2	1
H	38 thru 39	Hardened Steel >48	A2, 01, D2	150-400	.014-.027	.003-.006		1		2			NO	1	2

Note: Feed and speed recommendations are starting operating parameters. They are only guidelines from which further optimization should take place. Operating parameters are influenced by many machining variables. These variables may cause for reductions in feeds and speed or dramatic increases. Additionally, DOC and WOC may need to be revised to optimize the tools performance.



COMPLETE METALWORKING SOLUTIONS

(800) 991-4225
www.ahbinc.com
ISO Certified
customerservice@ahbinc.com