

QUADOPUS FINISH



Diameters:
2.00" - 8.00"

Depth of Cut Max:
.040" Max; .020" Recommended

Cutter Series:
DJ1H

Insert Series:
SNE_12

Materials:
Iron, Steel, Hardened Steel

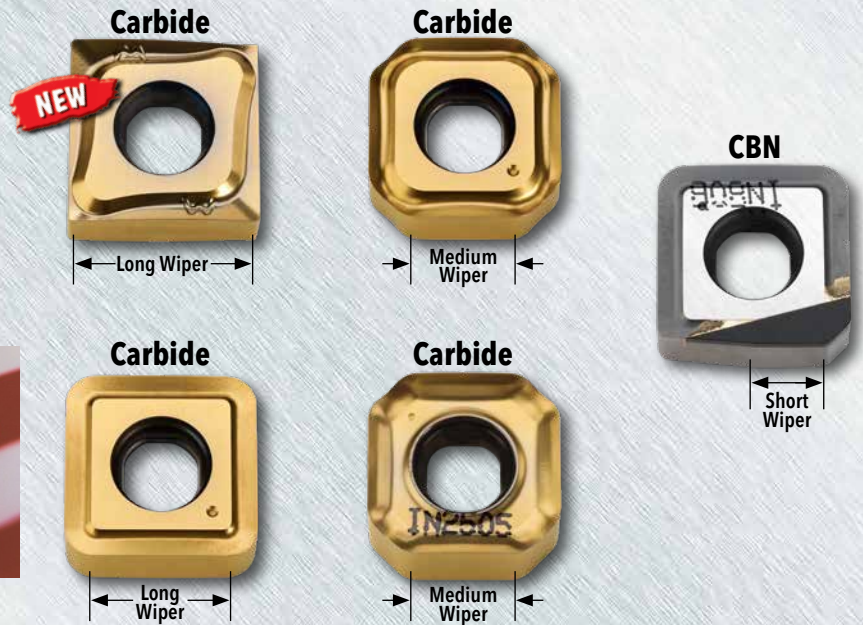

AHB Tooling & Machinery, Inc.
ISO Certified
(800) 991-4225
www.ahbinc.com
customerservice@ahbinc.com

Complete Metalworking Solutions
Roseville Saginaw & Jackson, MI

Finish-Milling cutters with easy set up and accurate adjustment

Features & Benefits:

- Fine adjustment within .0002" for runout and tolerance control
- 5-20 Ra surface finishes
- Carbide and CBN insert options
- Inserts with up to 8 indexes
- Inserts with Long, Medium & Short crowned wiper lengths for face pressure management
- Screw held inserts for secure mounting
- Cutter design accommodates milling up to a 90 degree shoulder
- Cutters with coarse and fine pitch densities for face pressure management

**PRODUCT
ANNOUNCEMENT
UPDATE
2018**

SERIES DJ1H

90° ADJUSTABLE FINISHING FACE MILL

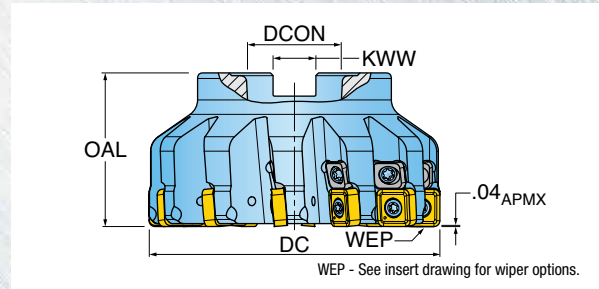





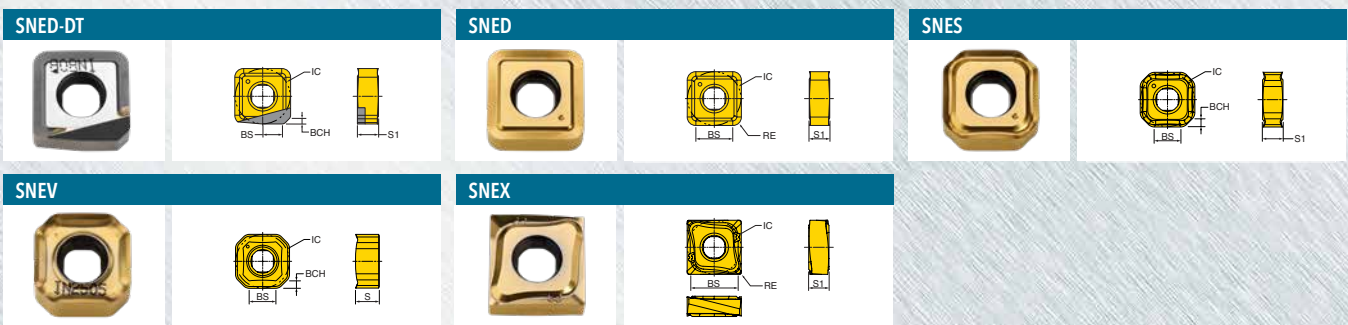

Part Number	DC Cutting Dia.	OAL Overall Length	ZEFF Effective Teeth	DCON Bore Dia.	KWW Keyway	DBC Bolt Circle
DJ1H-20R01	2.000	1.75	3	0.750	0.312	-
DJ1H-30R01	3.000	1.75	4	1.000	0.375	-
DJ1H-40R01	4.000	2.48	12	1.250	0.500	-
DJ1H-40R02	4.000	2.48	6	1.250	0.500	-
DJ1H-60R01	6.000	2.48	20	1.500	0.625	-
DJ1H-60R02	6.000	2.48	8	1.500	0.625	-
DJ1H-80R01	8.000	2.48	24	2.500	1.000	4.00
DJ1H-80R02	8.000	2.48	12	2.500	1.000	4.00

INSERTS



Part Number	RE/BCH Corner Radius/ Chamfer	BS Wiper Length	IC Inscribed Circle Dia.	S Thickness	NOI Number of Indexes	IH Insert Hand	Grade	IN80B	IN2510	IN2505
SNED1204ANR-DT	0.060 Chamfer	0.190	0.500	0.187	1	Right	•			
SNED120420	0.078 R	0.340	0.500	0.187	8	Right		•		
SNES1204ANN	0.100 Chamfer	0.230	0.500	0.187	8	Right		•		
SNEV1204ANN-PH	0.100 Chamfer	0.230	0.500	0.218	4	Right			•	
NEW SNEX120404R-W	0.015 R	0.470	0.500	0.187	4	Right				•

HARDWARE

						
	Insert Screw	Driver Handle	Driver Blade	Adjusting Screw	Adjusting Wedge	Retention Bolt
DJ1H-20R01	SM35-110-R0	DS-A00T	DS-T156B	SB060-10	2E-831-01	SD-06-46
DJ1H-30R01	SM35-110-R0	DS-A00T	DS-T156B	SB060-10	2E-831-01	SD-08-47
DJ1H-40R01	SM35-110-R0	DS-A00T	DS-T156B	SB060-10	2E-831-01	SD-10-47
DJ1H-40R02	SM35-110-R0	DS-A00T	DS-T156B	SB060-10	2E-831-01	SD-10-47
DJ1H-60R01	SM35-110-R0	DS-A00T	DS-T156B	SB060-10	2E-831-01	-
DJ1H-60R02	SM35-110-R0	DS-A00T	DS-T156B	SB060-10	2E-831-01	-
DJ1H-80R01	SM35-110-R0	DS-A00T	DS-T156B	SB060-10	2E-831-01	-
DJ1H-80R02	SM35-110-R0	DS-A00T	DS-T156B	SB060-10	2E-831-01	-

OPERATING GUIDELINES

QuadPlusFinish - DJ1H					IN2505	IN2510	IN80B	Coolant
Material	Brinnell Hardness	SFM	Feed per Insert					
Cast Iron	Gray	150 - 250	500-1000	.003-.008		1		No
			1400-2600	.003-.006			1	
	Nodular		400-800	.003-.008		1		
			1300-2000	.003-.006			1	
Steel	Carbon Steel	100-250	500-1000	.003-.008	1		No	
	Alloyed Steel	150-300	400-700		1			
Hardened Steel	Hardened Steel > 45 HRC	-	250-600	.003-.006			1	No

AXIAL ADJUSTMENT SET-UP

Component Identification:

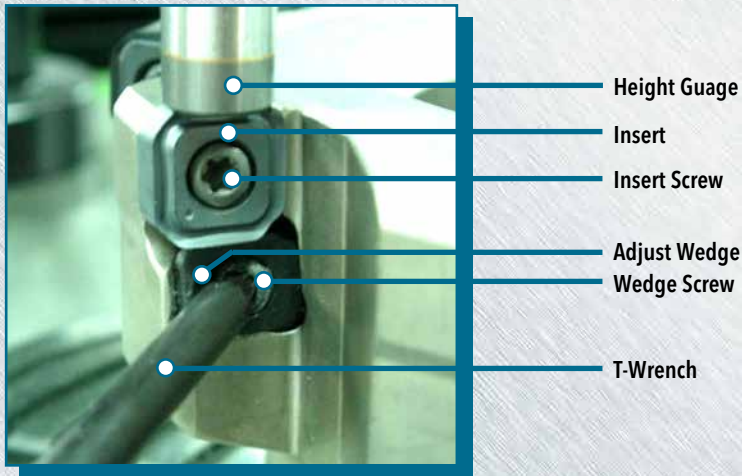

1

Rotating the wedge screw clockwise, tighten the wedge to the utmost.

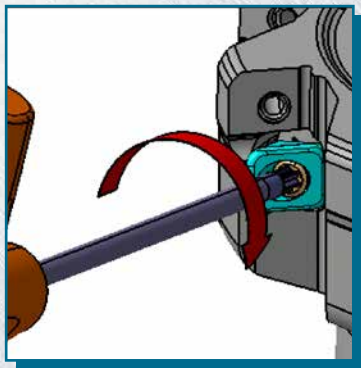

*Please note that you should tighten the wedge until it reaches the bottom of the pocket. Avoid using too much force.

2

Mount the insert.



*Tighten the insert screw completely (35in. lbs.)

3

Upon tightening of inserts, measure the cutter run-out, select the highest insert as a datum.



*Do not damage the insert edge on gauge setting.

Continue set-up on next page...

AXIAL ADJUSTMENT SET-UP (CONTINUED)

4 Set up the cutter height, raising one insert by turning the wedge screw counter-clockwise.



*Adjust 0.01mm (.0004") at least.

5 Adjust AXIAL RUNOUT of the remaining inserts the same way as the original insert.



*Note: The adjustable amount should not be over 0.1mm (.004").

*GAUGE user guide.



5.1 Adjust AXIAL RUNOUT by rotating the wrench gradually until it meets the 0.005mm (.0002") range.



5.2 When beyond the acceptable range. Please reset it with steps (1), (2), and (5).



6 RUNOUT adjustment is completed. (Do not clamp the insert screw any further once it is fixed.)



Continue set-up on next page...

AXIAL ADJUSTMENT SET-UP (CONTINUED)

Note on Setting:

- When you change the insert corner, please start over from 1st step.
- You must remove dirt & debris on the surface of inserts or pockets before mounting inserts as this product requires high accuracy.
- When you reassemble the wedge after completely separating it, please put it together as in picture (3).

1 **NO**
Gap between wedge and pocket bottom with screw bottomed out.

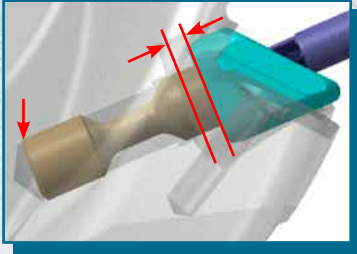

2 **NO**
Wedge bottomed out with screw excessively sticking out of top of wedge.

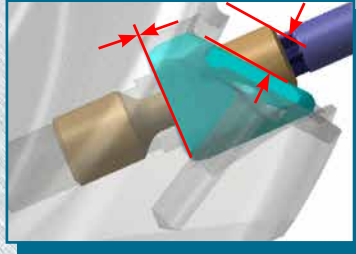

3 **YES**
Wedge bottomed out and screw is below wedge.

