

### HOLEMAKING

#### Diameter Range

0.1562"-0.4687"  
4.0 mm-12.0 mm

#### Bodies

Self-Centering  
3xD, 5xD, **8xD** **NEW**

Flat Bottom  
3xD, 5xD **NEW**

Cylindrical Shank

#### Geometries

3-Flute  
FR (140° Self-Centering)  
**FF (Flat Bottom)** **NEW**

#### Grade

IN2205

#### Materials

- Steel
- Cast Iron

# SOLID DRILL 3™

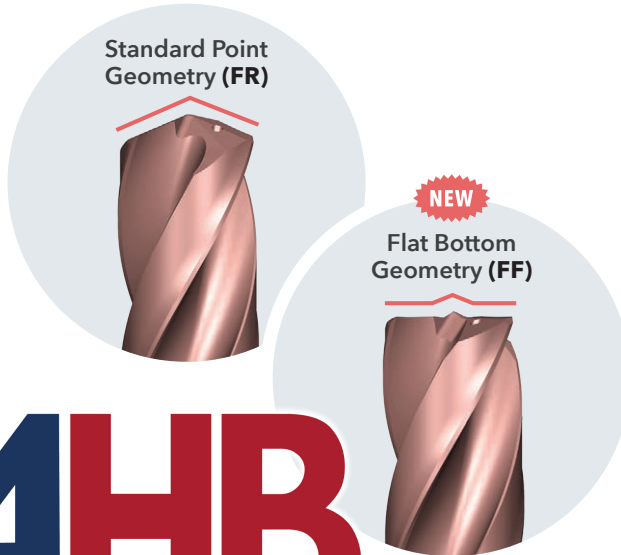

### 3-Flute Solid Drills Expanded to 8xD Depth and New Flat Bottom Geometry

- » 3-flute design allows up to 50% higher feed rates.
- » Flat bottom geometry ideal for drilling cavities in bolt holes.
- » Self-centering geometry eliminates need to pilot up to 8xD.

# AHB

TOOLING & MACHINERY

COMPLETE METALWORKING SOLUTIONS

(800) 991-4225 [www.ahbinc.com](http://www.ahbinc.com)  
ISO Certified [customerservice@ahbinc.com](mailto:customerservice@ahbinc.com)



**NEW**

**NEW**

**NEW**

See it in action! »



**WINSPEED™**  
ADVANCED MACHINING

[ingersoll-imc.com](http://ingersoll-imc.com)



# New flat bottom geometry and 8xD drilling depth option added to SolidDrill3

As part of the new Winsfeed campaign, Ingersoll is expanding the range and utility of the **SolidDrill<sup>3</sup>** product line by adding an 8xD option to the available lengths and a Flat Bottom Geometry for drilling bolt holes with 3xD and 5xD options.

The **SolidDrill<sup>3</sup>** is a 3-flute solid carbide drill capable of 50% higher feed rates compared to conventional 2-flute drills. It also features a unique edge design that improves machining stability needed for the more aggressive cutting conditions and a self-centering geometry to eliminate the need for a pilot hole up to 8xD. SolidDrill3 is an ideal, high-performance solution for high production drilling applications, especially in steel and cast-iron machining.

## Features & Benefits





---

- Drill range: .157" - .472" (.031" increments), 4.0 - 12.0 mm (0.5 mm increments)
- 3-flute geometry increases productivity by at least 50%
- Self-centering geometry provides precise and accurate holes without a pre-hole
- Very high stability in the cut due to its specially designed edge geometry
  - » Reinforced cutting edge
  - » Side geometry that minimizes heat and reduces cutting forces
- 3 coolant outlet holes to maximize coolant flow and evacuate chips
- New PVD coated grade IN2205 in a new bronze color provides consistency and longer life
- Suitable for steel and cast-iron drilling



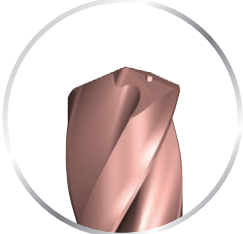

## Features & Benefits (cont.)

- 3 flute Solid Carbide Drills with Coolant Hole (FR Series)
  - » Drilling depth: 3xD, 5xD and 8xD
  - » Symmetric point design allows drilling without a pilot hole

Head Shape	Drill	
FR 	3xD	
	5xD	
	<b>NEW</b> 8xD	

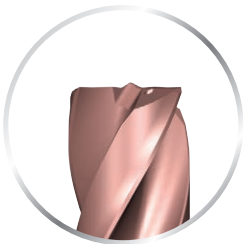
- 3 flute Flat Bottom Solid Carbide Drills with Coolant Hole (FF Series)
  - » Drilling depth: 3xD, 5xD
  - » Excellent performance for flat bottom hole applications

Head Shape	Drill	
FF 	<b>NEW</b> 3xD	
	<b>NEW</b> 5xD	

Drilling Coolant



## 8xD • Series FR

### 3-FLUTE SOLID CARBIDE DRILLS WITH COOLANT HOLES

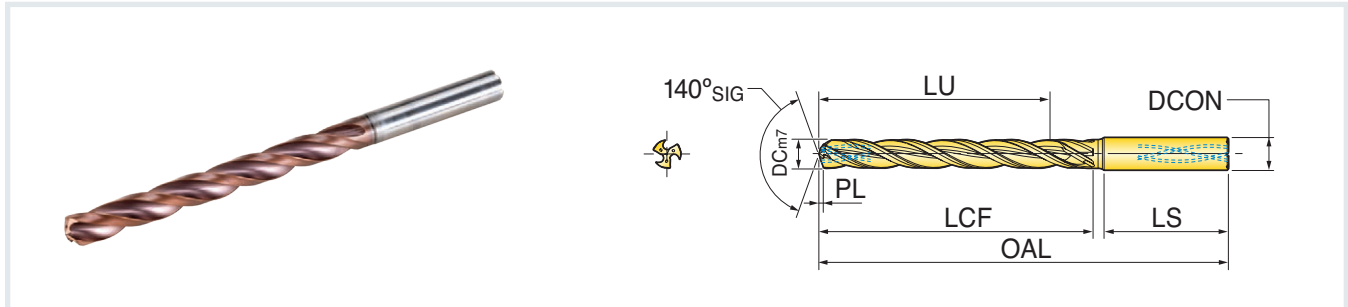

Part Number	DC Cutting Dia.		PL Point Length	LU Usable Length	LCF Chip Flute Length	LS Shank Length	OAL Overall Length	DCON Shank Dia.
	INCH (MM)	FRACTION						
FR0397036T7R01	0.1563 (3.97 mm)	5/32"	0.82	36	43	35	81	6
FR0400036T7R01	0.1575 (4.00 mm)	-	0.82	36	43	35	81	6
FR0450036T7R01	0.1772 (4.50 mm)	-	0.88	36	43	35	81	6
FR0476036T7R01	0.1875 (4.76 mm)	3/16"	0.95	36	43	35	81	6
FR0500048T7R01	0.1969 (5.00 mm)	-	0.96	48	57	36	95	6
FR0550048T7R01	0.2165 (5.50 mm)	-	1.08	48	57	36	95	6
FR0556048T7R01	0.2188 (5.56 mm)	7/32"	1.12	48	57	36	95	6
FR0600048T7R01	0.2362 (6.00 mm)	-	1.17	48	57	36	95	6
FR0635064TOR01	0.2500 (6.35 mm)	1/4"	1.25	64	76	36	114	8
FR0650064TOR01	0.2559 (6.50 mm)	-	1.26	64	76	36	114	8
FR0700064TOR01	0.2756 (7.00 mm)	-	1.35	64	76	36	114	8
FR0714064TOR01	0.2813 (7.14 mm)	9/32"	1.35	64	76	36	114	8
FR0750064TOR01	0.2953 (7.50 mm)	-	1.4	64	76	36	114	8
FR0794064TOR01	0.3125 (7.94 mm)	5/16"	1.49	64	76	36	114	8
FR0800064TOR01	0.3150 (8.00 mm)	-	1.49	64	76	36	114	8
FR0850080T1R01	0.3346 (8.50 mm)	-	2.04	80	95	40	142	10
FR0873080T1R01	0.3438 (8.73 mm)	11/32"	2.09	80	95	40	142	10
FR0900080T1R01	0.3543 (9.00 mm)	-	2.16	80	95	40	142	10
FR0950080T1R01	0.3740 (9.50 mm)	-	2.29	80	95	40	142	10
FR0953080T1R01	0.3750 (9.53 mm)	3/8"	2.29	80	95	40	142	10
FR1000080T1R01	0.3937 (10.00 mm)	-	2.33	80	95	40	142	10
FR1030096T2R01	0.4055 (10.30 mm)	13/32"	2.45	96	113	45	162	12
FR1050096T2R01	0.4134 (10.50 mm)	-	2.5	96	113	45	162	12
FR1100096T2R01	0.4331 (11.00 mm)	-	2.61	96	113	45	162	12
FR1111096T2R01	0.4375 (11.11 mm)	7/16"	2.58	96	113	45	162	12
FR1150096T2R01	0.4528 (11.50 mm)	-	2.67	96	113	45	162	12
FR1191096T2R01	0.4688 (11.91 mm)	15/32"	2.77	96	113	45	162	12
FR1200096T2R01	0.4724 (12.00 mm)	-	2.8	96	113	45	162	12

Drilling Coolant



## 3xD • Series FF

### 3-FLUTE FLAT BOTTOM SOLID CARBIDE DRILLS WITH COOLANT HOLES

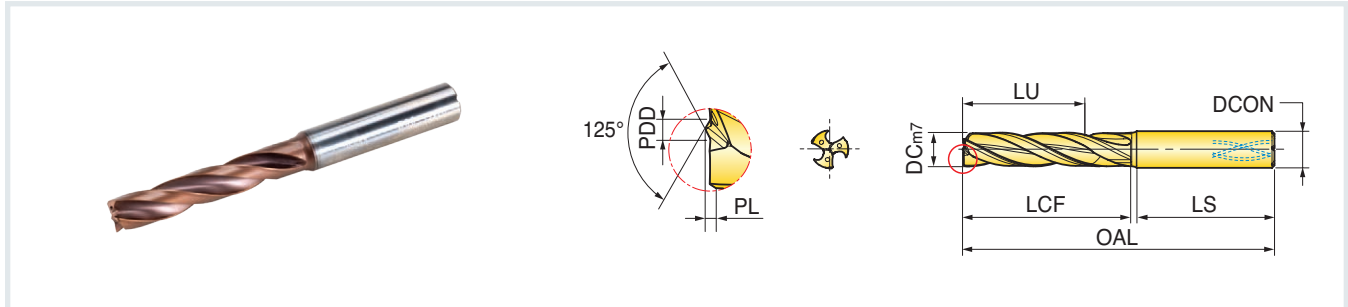

Part Number	DC Cutting Dia.		PL Point Length	LU Usable Length	LCF Chip Flute Length	LS Shank Length	OAL Overall Length	DCON Shank Dia.	PDD Drill Point Dia.
	INCH (MM)	FRACTION							
FF0397017T7R01	0.1560 (3.97 mm)	5/32"	0.43	17	25	35	66	6	0.77
FF0400017T7R01	0.1575 (4.00 mm)	-	0.43	17	25	35	66	6	0.77
FF0410017T7R01	0.1614 (4.10 mm)	-	0.43	17	25	35	66	6	0.77
FF0420017T7R01	0.1654 (4.20 mm)	-	0.43	17	25	35	66	6	0.77
FF0430017T7R01	0.1693 (4.30 mm)	-	0.45	17	25	35	66	6	0.86
FF0440017T7R01	0.1732 (4.40 mm)	-	0.45	17	25	35	66	6	0.86
FF0450017T7R01	0.1772 (4.50 mm)	-	0.45	17	25	35	66	6	0.86
FF0460017T7R01	0.1811 (4.60 mm)	7/32"	0.45	17	25	35	66	6	0.86
FF0470017T7R01	0.1850 (4.70 mm)	-	0.45	17	25	35	66	6	0.86
FF0476017T7R01	0.1875 (4.76 mm)	3/16"	0.45	17	25	35	66	6	0.86
FF0480020T7R01	0.1890 (4.80 mm)	-	0.47	20	29	36	66	6	0.97
FF0490020T7R01	0.1929 (4.90 mm)	-	0.47	20	29	36	66	6	0.97
FF0500020T7R01	0.1969 (5.00 mm)	-	0.47	20	29	36	66	6	0.97
FF0510020T7R01	0.2008 (5.10 mm)	-	0.47	20	29	36	66	6	0.97
FF0520020T7R01	0.2047 (5.20 mm)	-	0.47	20	29	36	66	6	0.97
FF0530020T7R01	0.2087 (5.30 mm)	-	0.47	20	29	36	66	6	0.97
FF0540020T7R01	0.2126 (5.40 mm)	-	0.58	20	29	36	66	6	1.08
FF0550020T7R01	0.2165 (5.50 mm)	-	0.58	20	29	36	66	6	1.08
FF0556020T7R01	0.2190 (5.56 mm)	7/32"	0.58	20	29	36	66	6	1.08
FF0560020T7R01	0.2205 (5.60 mm)	-	0.58	20	29	36	66	6	1.08
FF0570020T7R01	0.2244 (5.70 mm)	-	0.58	20	29	36	66	6	1.08
FF0580020T7R01	0.2283 (5.80 mm)	-	0.58	20	29	36	66	6	1.08
FF0590020T7R01	0.2323 (5.90 mm)	-	0.58	20	29	36	66	6	1.08
FF0600020T7R01	0.2362 (6.00 mm)	-	0.58	20	29	36	66	6	1.08
FF0610024TOR01	0.2402 (6.10 mm)	-	0.62	24	35	36	79	8	1.26
FF0620024TOR01	0.2441 (6.20 mm)	-	0.62	24	35	36	79	8	1.26
FF0630024TOR01	0.2480 (6.30 mm)	-	0.62	24	35	36	79	8	1.26
FF0635024TOR01	0.2500 (6.35 mm)	1/4"	0.62	24	35	36	79	8	1.26
FF0640024TOR01	0.2520 (6.40 mm)	-	0.62	24	35	36	79	8	1.26
FF0650024TOR01	0.2559 (6.50 mm)	-	0.62	24	35	36	79	8	1.26
FF0660024TOR01	0.2598 (6.60 mm)	-	0.62	24	35	36	79	8	1.26

Drilling Coolant



## 3xD • Series FF (continued)

### 3-FLUTE FLAT BOTTOM SOLID CARBIDE DRILLS WITH COOLANT HOLES

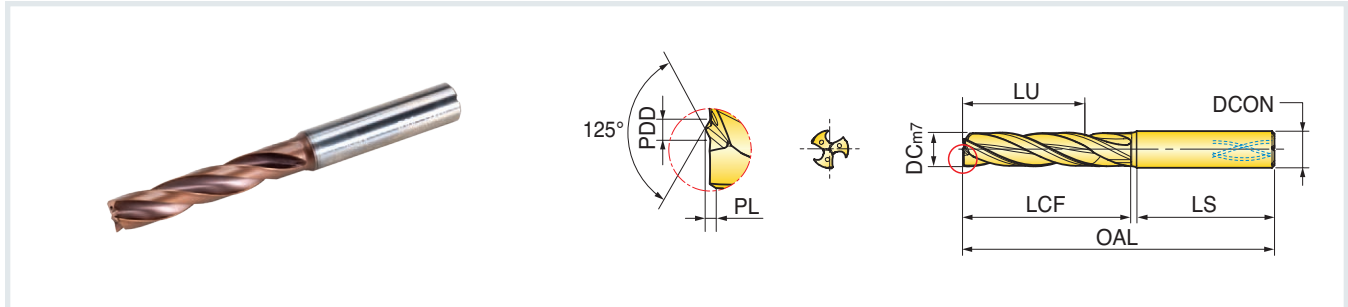

Part Number	DC Cutting Dia.		PL Point Length	LU Usable Length	LCF Chip Flute Length	LS Shank Length	OAL Overall Length	DCON Shank Dia.	PDD Drill Point Dia.
	INCH (MM)	FRACTION							
FF0670024TOR01	0.2638 (6.70 mm)	-	0.62	24	35	36	79	8	1.26
FF0680024TOR01	0.2680 (6.80 mm)	-	0.62	24	35	36	79	8	1.26
FF0690024TOR01	0.2717 (6.90 mm)	-	0.62	24	35	36	79	8	1.26
FF0700024TOR01	0.2756 (7.00 mm)	-	0.62	24	35	36	79	8	1.26
FF0710024TOR01	0.2795 (7.10 mm)	-	0.66	24	42	36	79	8	1.44
FF0714029TOR01	0.2813 (7.14 mm)	9/32"	0.66	29	42	36	79	8	1.44
FF0720029TOR01	0.2835 (7.20 mm)	-	0.66	29	42	36	79	8	1.44
FF0730029TOR01	0.2874 (7.30 mm)	-	0.66	29	42	36	79	8	1.44
FF0740029TOR01	0.2913 (7.40 mm)	-	0.66	29	42	36	79	8	1.44
FF0750029TOR01	0.2953 (7.50 mm)	-	0.66	29	42	36	79	8	1.44
FF0760029TOR01	0.2992 (7.60 mm)	-	0.66	29	42	36	79	8	1.44
FF0770029TOR01	0.3031 (7.70 mm)	-	0.66	29	42	36	79	8	1.44
FF0780029TOR01	0.3071 (7.80 mm)	-	0.66	29	42	36	79	8	1.44
FF0790029TOR01	0.3110 (7.90 mm)	-	0.66	29	42	36	79	8	1.44
FF0794029TOR01	0.3130 (7.94 mm)	5/16"	0.66	29	42	36	79	8	1.44
FF0800029TOR01	0.3150 (8.00 mm)	-	0.66	29	42	36	79	8	1.44
FF0810035T1R01	0.3189 (8.10 mm)	-	0.79	35	48	40	89	10	1.62
FF0820035T1R01	0.3228 (8.20 mm)	-	0.79	35	48	40	89	10	1.62
FF0830035T1R01	0.3268 (8.30 mm)	-	0.79	35	48	40	89	10	1.62
FF0840035T1R01	0.3307 (8.40 mm)	-	0.79	35	48	40	89	10	1.62
FF0850035T1R01	0.3346 (8.50 mm)	-	0.79	35	48	40	89	10	1.62
FF0860035T1R01	0.3386 (8.60 mm)	-	0.79	35	48	40	89	10	1.62
FF0870035T1R01	0.3425 (8.70 mm)	-	0.79	35	48	40	89	10	1.62
FF0873035T1R01	0.3440 (8.73 mm)	11/32"	0.79	35	48	40	89	10	1.62
FF0880035T1R01	0.3465 (8.80 mm)	-	0.79	35	48	40	89	10	1.62
FF0890035T1R01	0.3504 (8.90 mm)	-	0.79	35	48	40	89	10	1.62
FF0900035T1R01	0.3543 (9.00 mm)	-	0.79	35	48	40	89	10	1.62
FF0910035T1R01	0.3583 (9.10 mm)	-	0.82	35	48	40	89	10	1.80
FF0920035T1R01	0.3622 (9.20 mm)	-	0.82	35	48	40	89	10	1.80
FF0930035T1R01	0.3661 (9.30 mm)	-	0.82	35	48	40	89	10	1.80

Drilling Coolant



## 3xD • Series FF (continued)

### 3-FLUTE FLAT BOTTOM SOLID CARBIDE DRILLS WITH COOLANT HOLES

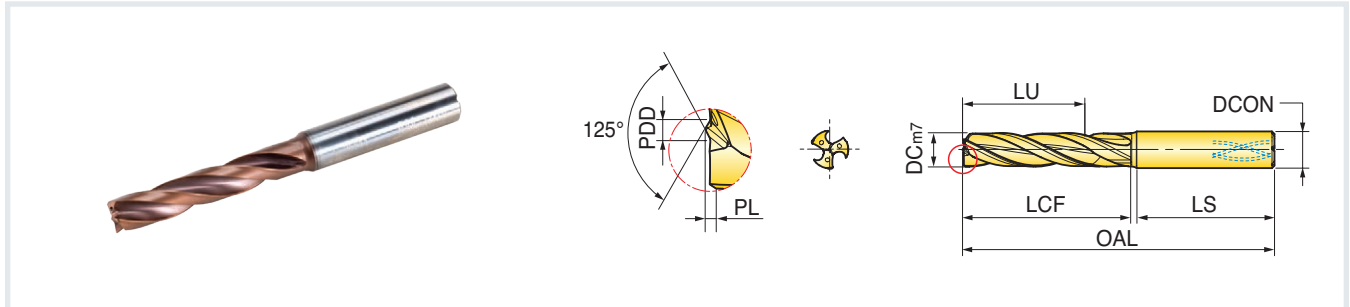

Part Number	DC Cutting Dia.		PL Point Length	LU Usable Length	LCF Chip Flute Length	LS Shank Length	OAL Overall Length	DCON Shank Dia.	PDD Drill Point Dia.
	INCH (MM)	FRACTION							
FF0940035T1R01	0.3701 (9.40 mm)	-	0.82	35	48	40	89	10	1.80
FF0950035T1R01	0.3740 (9.50 mm)	-	0.82	35	48	40	89	10	1.80
FF0953035T1R01	0.3750 (9.53 mm)	3/8"	0.82	35	48	40	89	10	1.80
FF0960035T1R01	0.3780 (9.60 mm)	-	0.82	35	48	40	89	10	1.80
FF0970035T1R01	0.3819 (9.70 mm)	-	0.82	35	48	40	89	10	1.80
FF0980035T1R01	0.3858 (9.80 mm)	-	0.82	35	48	40	89	10	1.80
FF0990035T1R01	0.3998 (9.90 mm)	-	0.82	35	48	40	89	10	1.80
FF1000035T1R01	0.3937 (10.00 mm)	-	0.82	35	48	40	89	10	1.80
FF1010040T2R01	0.3976 (10.10 mm)	-	0.95	40	55	45	102	12	1.98
FF1020040T2R01	0.4016 (10.20 mm)	-	0.95	40	55	45	102	12	1.98
FF1030040T2R01	0.4055 (10.30 mm)	13/32"	0.95	40	55	45	102	12	1.98
FF1040040T2R01	0.4094 (10.40 mm)	-	0.95	40	55	45	102	12	1.98
FF1050040T2R01	0.4134 (10.50 mm)	-	0.95	40	55	45	102	12	1.98
FF1060040T2R01	0.4173 (10.60 mm)	-	0.95	40	55	45	102	12	1.98
FF1070040T2R01	0.4213 (10.70 mm)	-	0.95	40	55	45	102	12	1.98
FF1080040T2R01	0.4252 (10.80 mm)	-	0.95	40	55	45	102	12	1.98
FF1090040T2R01	0.4291 (10.90 mm)	-	0.95	40	55	45	102	12	1.98
FF1100040T2R01	0.4331 (11.00 mm)	-	0.95	40	55	45	102	12	1.98
FF111040T2R01	0.4370 (11.10 mm)	-	0.98	40	56	45	102	12	2.16
FF111040T2R01	0.4375 (11.11 mm)	7/16"	0.98	40	56	45	102	12	2.16
FF1120040T2R01	0.4409 (11.20 mm)	-	0.98	40	56	45	102	12	2.16
FF1130040T2R01	0.4449 (11.30 mm)	-	0.98	40	56	45	102	12	2.16
FF1140040T2R01	0.4488 (11.40 mm)	-	0.98	40	56	45	102	12	2.16
FF1150040T2R01	0.4528 (11.50 mm)	-	0.98	40	56	45	102	12	2.16
FF1160040T2R01	0.4567 (11.60 mm)	-	0.98	40	56	45	102	12	2.16
FF1170040T2R01	0.4606 (11.70 mm)	-	0.98	40	56	45	102	12	2.16
FF1180040T2R01	0.4646 (11.80 mm)	-	0.98	40	56	45	102	12	2.16
FF1190040T2R01	0.4685 (11.90 mm)	-	0.98	40	56	45	102	12	2.16
FF1191040T2R01	0.4688 (11.91 mm)	15/32"	0.98	40	56	45	102	12	2.16
FF1200040T2R01	0.4724 (12.00 mm)	-	0.98	40	56	45	102	12	2.16

Drilling Coolant



## 5xD • Series FF

### 3-FLUTE FLAT BOTTOM SOLID CARBIDE DRILLS WITH COOLANT HOLES

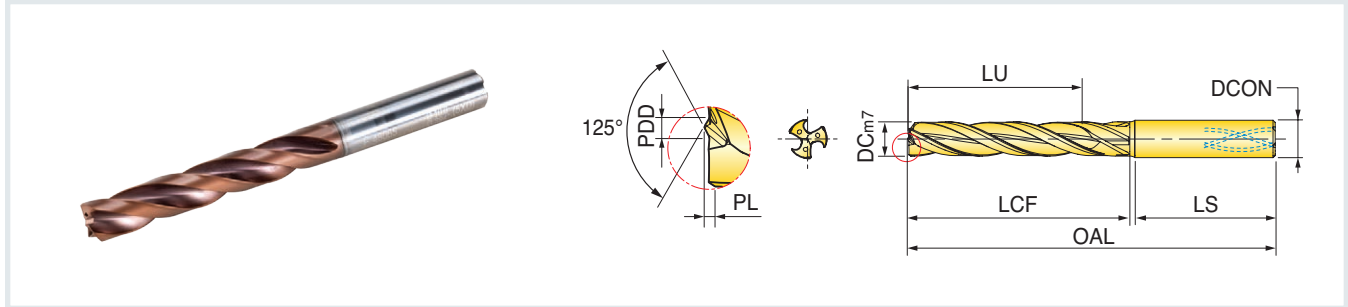

Part Number	DC Cutting Dia.		PL Point Length	LU Usable Length	LCF Chip Flute Length	LS Shank Length	OAL Overall Length	DCON Shank Dia.	PDD Drill Point Dia.
	INCH (MM)	FRACTION							
FF0397029T7R01	0.1560 (3.97 mm)	5/32"	0.43	29	25	35	74	6	0.77
FF0400029T7R01	0.1575 (4.00 mm)	-	0.43	29	25	35	74	6	0.77
FF0410029T7R01	0.1614 (4.10 mm)	-	0.43	29	25	35	74	6	0.77
FF0420029T7R01	0.1654 (4.20 mm)	-	0.43	29	25	35	74	6	0.77
FF0430029T7R01	0.1693 (4.30 mm)	-	0.45	29	25	35	74	6	0.86
FF0440029T7R01	0.1732 (4.40 mm)	-	0.45	29	25	35	74	6	0.86
FF0450029T7R01	0.1772 (4.50 mm)	-	0.45	29	25	35	74	6	0.86
FF0460029T7R01	0.1811 (4.60 mm)	7/32"	0.45	29	25	35	82	6	0.86
FF0470029T7R01	0.1850 (4.70 mm)	-	0.45	29	25	35	82	6	0.86
FF0476029T7R01	0.1875 (4.76 mm)	3/16"	0.45	29	25	35	82	6	0.86
FF0480035T7R01	0.1890 (4.80 mm)	-	0.47	35	29	36	82	6	0.97
FF0490035T7R01	0.1929 (4.90 mm)	-	0.47	35	29	36	82	6	0.97
FF0500035T7R01	0.1969 (5.00 mm)	-	0.47	35	29	36	82	6	0.97
FF0510035T7R01	0.2008 (5.10 mm)	-	0.47	35	29	36	82	6	0.97
FF0520035T7R01	0.2047 (5.20 mm)	-	0.47	35	29	36	82	6	0.97
FF0530035T7R01	0.2087 (5.30 mm)	-	0.47	35	29	36	82	6	0.97
FF0540035T7R01	0.2126 (5.40 mm)	-	0.58	35	29	36	82	6	1.08
FF0550035T7R01	0.2165 (5.50 mm)	-	0.58	35	29	36	82	6	1.08
FF0556035T7R01	0.2190 (5.56 mm)	7/32"	0.58	35	29	36	82	6	1.08
FF0560035T7R01	0.2205 (5.60 mm)	-	0.58	35	29	36	82	6	1.08
FF0570035T7R01	0.2244 (5.70 mm)	-	0.58	35	29	36	82	6	1.08
FF0580035T7R01	0.2283 (5.80 mm)	-	0.58	35	29	36	82	6	1.08
FF0590035T7R01	0.2323 (5.90 mm)	-	0.58	35	29	36	82	6	1.08
FF0600035T7R01	0.2362 (6.00 mm)	-	0.58	35	29	36	82	6	1.08
FF0610043TOR01	0.2402 (6.10 mm)	-	0.62	43	35	36	91	8	1.26
FF0620043TOR01	0.2441 (6.20 mm)	-	0.62	43	35	36	91	8	1.26
FF0630043TOR01	0.2480 (6.30 mm)	-	0.62	43	35	36	91	8	1.26
FF0635024TOR01	0.2500 (6.35 mm)	1/4"	0.62	43	35	36	91	8	1.26
FF0640043TOR01	0.2520 (6.40 mm)	-	0.62	43	35	36	91	8	1.26
FF0650043TOR01	0.2559 (6.50 mm)	-	0.62	43	35	36	91	8	1.26
FF0660043TOR01	0.2598 (6.60 mm)	-	0.62	43	35	36	91	8	1.26



Drilling Coolant



## 5xD • Series FF (continued)

### 3-FLUTE FLAT BOTTOM SOLID CARBIDE DRILLS WITH COOLANT HOLES

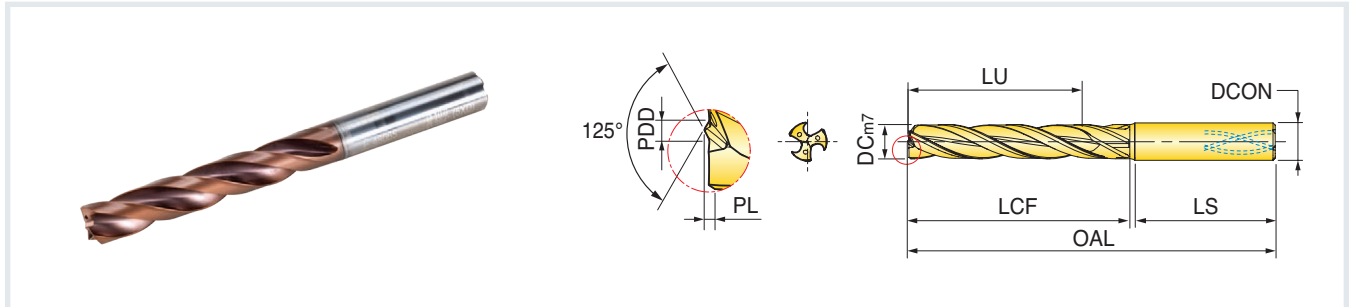

Part Number	DC Cutting Dia.		PL Point Length	LU Usable Length	LCF Chip Flute Length	LS Shank Length	OAL Overall Length	DCON Shank Dia.	PDD Drill Point Dia.
	INCH (MM)	FRACTION							
FF0670043TOR01	0.2638 (6.70 mm)	-	0.62	43	35	36	91	8	1.26
FF0680043TOR01	0.2680 (6.80 mm)	-	0.62	43	35	36	91	8	1.26
FF0690043TOR01	0.2717 (6.90 mm)	-	0.62	43	35	36	91	8	1.26
FF0700043TOR01	0.2756 (7.00 mm)	-	0.62	43	35	36	91	8	1.26
FF0710043TOR01	0.2795 (7.10 mm)	-	0.66	43	42	36	91	8	1.44
FF0714043TOR01	0.2813 (7.14 mm)	9/32"	0.66	43	42	36	91	8	1.44
FF0720043TOR01	0.2835 (7.20 mm)	-	0.66	43	42	36	91	8	1.44
FF0730043TOR01	0.2874 (7.30 mm)	-	0.66	43	42	36	91	8	1.44
FF0740043TOR01	0.2913 (7.40 mm)	-	0.66	43	42	36	91	8	1.44
FF0750043TOR01	0.2953 (7.50 mm)	-	0.66	43	42	36	91	8	1.44
FF0760043TOR01	0.2992 (7.60 mm)	-	0.66	43	42	36	91	8	1.44
FF0770043TOR01	0.3031 (7.70 mm)	-	0.66	43	42	36	91	8	1.44
FF0780043TOR01	0.3071 (7.80 mm)	-	0.66	43	42	36	91	8	1.44
FF0790043TOR01	0.3110 (7.90 mm)	-	0.66	43	42	36	91	8	1.44
FF0794043TOR01	0.3130 (7.94 mm)	5/16"	0.66	43	42	36	91	8	1.44
FF0800043TOR01	0.3150 (8.00 mm)	-	0.66	43	42	36	91	8	1.44
FF0810049T1R01	0.3189 (8.10 mm)	-	0.79	49	48	40	103	10	1.62
FF0820049T1R01	0.3228 (8.20 mm)	-	0.79	49	48	40	103	10	1.62
FF0830049T1R01	0.3268 (8.30 mm)	-	0.79	49	48	40	103	10	1.62
FF0840049T1R01	0.3307 (8.40 mm)	-	0.79	49	48	40	103	10	1.62
FF0850049T1R01	0.3346 (8.50 mm)	-	0.79	49	48	40	103	10	1.62
FF0860049T1R01	0.3386 (8.60 mm)	-	0.79	49	48	40	103	10	1.62
FF0870049T1R01	0.3425 (8.70 mm)	-	0.79	49	48	40	103	10	1.62
FF0873049T1R01	0.3440 (8.73 mm)	11/32"	0.79	49	48	40	103	10	1.62
FF0880049T1R01	0.3465 (8.80 mm)	-	0.79	49	48	40	103	10	1.62
FF0890049T1R01	0.3504 (8.90 mm)	-	0.79	49	48	40	103	10	1.62
FF0900049T1R01	0.3543 (9.00 mm)	-	0.79	49	48	40	103	10	1.62
FF0910049T1R01	0.3583 (9.10 mm)	-	0.82	49	48	40	103	10	1.80
FF0920049T1R01	0.3622 (9.20 mm)	-	0.82	49	48	40	103	10	1.80
FF0930049T1R01	0.3661 (9.30 mm)	-	0.82	49	48	40	103	10	1.80

Drilling Coolant



## 5xD • Series FF (continued)

### 3-FLUTE FLAT BOTTOM SOLID CARBIDE DRILLS WITH COOLANT HOLES

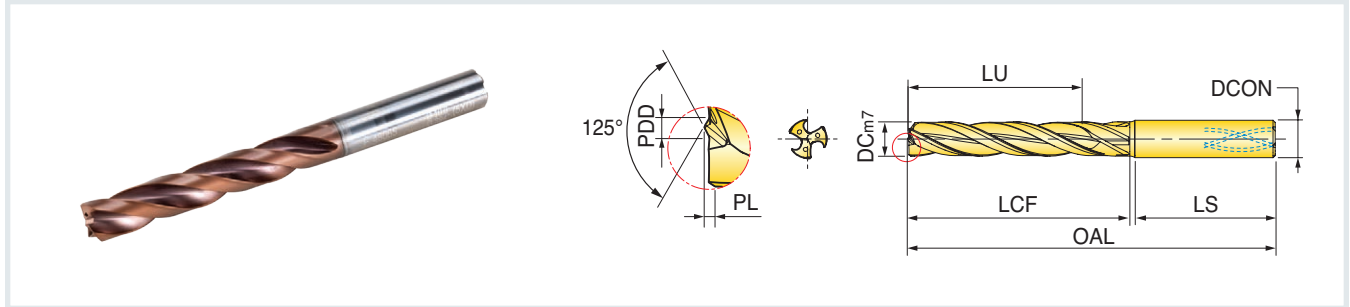

Part Number	DC Cutting Dia.		PL Point Length	LU Usable Length	LCF Chip Flute Length	LS Shank Length	OAL Overall Length	DCON Shank Dia.	PDD Drill Point Dia.
	INCH (MM)	FRACTION							
FF0940049T1R01	0.3701 (9.40 mm)	-	0.82	49	48	40	103	10	1.80
FF0950049T1R01	0.3740 (9.50 mm)	-	0.82	49	48	40	103	10	1.80
FF0953049T1R01	0.3750 (9.53 mm)	3/8"	0.82	49	48	40	103	10	1.80
FF0960049T1R01	0.3780 (9.60 mm)	-	0.82	49	48	40	103	10	1.80
FF0970049T1R01	0.3819 (9.70 mm)	-	0.82	49	48	40	103	10	1.80
FF0980049T1R01	0.3858 (9.80 mm)	-	0.82	49	48	40	103	10	1.80
FF0990049T1R01	0.3998 (9.90 mm)	-	0.82	49	48	40	103	10	1.80
FF1000049T1R01	0.3937 (10.00 mm)	-	0.82	49	48	40	103	10	1.80
FF1010056T2R01	0.3976 (10.10 mm)	-	0.95	56	55	45	118	12	1.98
FF1020056T2R01	0.4016 (10.20 mm)	-	0.95	56	55	45	118	12	1.98
FF1030056T2R01	0.4055 (10.30 mm)	13/32"	0.95	56	55	45	118	12	1.98
FF1040056T2R01	0.4094 (10.40 mm)	-	0.95	56	55	45	118	12	1.98
FF1050056T2R01	0.4134 (10.50 mm)	-	0.95	56	55	45	118	12	1.98
FF1060056T2R01	0.4173 (10.60 mm)	-	0.95	56	55	45	118	12	1.98
FF1070056T2R01	0.4213 (10.70 mm)	-	0.95	56	55	45	118	12	1.98
FF1080056T2R01	0.4252 (10.80 mm)	-	0.95	56	55	45	118	12	1.98
FF1090056T2R01	0.4291 (10.90 mm)	-	0.95	56	55	45	118	12	1.98
FF1100056T2R01	0.4331 (11.00 mm)	-	0.95	56	55	45	118	12	1.98
FF1110056T2R01	0.4370 (11.10 mm)	-	0.95	56	55	45	118	12	2.16
FF1111056T2R01	0.4375 (11.11 mm)	7/16"	0.98	56	56	45	118	12	2.16
FF1120056T2R01	0.4409 (11.20 mm)	-	0.98	56	56	45	118	12	2.16
FF1130056T2R01	0.4449 (11.30 mm)	-	0.98	56	56	45	118	12	2.16
FF1140056T2R01	0.4488 (11.40 mm)	-	0.98	56	56	45	118	12	2.16
FF1150056T2R01	0.4528 (11.50 mm)	-	0.98	56	56	45	118	12	2.16
FF1160056T2R01	0.4567 (11.60 mm)	-	0.98	56	56	45	118	12	2.16
FF1170056T2R01	0.4606 (11.70 mm)	-	0.98	56	56	45	118	12	2.16
FF1180056T2R01	0.4646 (11.80 mm)	-	0.98	56	56	45	118	12	2.16
FF1190056T2R01	0.4685 (11.90 mm)	-	0.98	56	56	45	118	12	2.16
FF1191056T2R01	0.4688 (11.91 mm)	15/32"	0.98	56	56	45	118	12	2.16
FF1200056T2R01	0.4724 (12.00 mm)	-	0.98	56	56	45	118	12	2.16

## Operating Guidelines

ISO	Matl' Group No.	Condition	Hardness HB	Vc Cutting Speed SFM	Feed vs. Drill Diameter inch/rev (mm/rev)									
					.157" - .197"	.198" - .236"	.237" - .315"	.316" - .394"	.395" - .472"					
					4mm - 5mm	5.1mm - 6mm	6.1mm - 8mm	8.1mm - 10mm	10.1mm - 12mm					
<b>P</b>	1	Low carbon steels (C < 0.3)	125	262 - 459	.006 - .010	.008 - .014	.010 - .018	.012 - .022	.014 - .024					
	2		190	262 - 427										
	3	Carbon steels (C > 0.3)	250	262 - 294										
	4		220	230 - 361										
	5		300	154 - 295										
	6	Low alloy steels	200	262 - 394										
	7		275	230 - 361										
	8		300	154 - 295										
	9		350	131 - 230										
	10	Alloy steels	200	154 - 295						.006 - .008	.008 - .012	.010 - .014	.012 - .018	.014 - .020
	11		325	131 - 262										
<b>K</b>	15	Grey Cast Iron	160	262 - 459	.008 - .012	.008 - .016	.012 - .020	.014 - .022	.016 - .024					
	16		250	230 - 394										
	17	Nodular Cast Iron	180	262 - 394										
	18		260	230 - 361										
	19	Malleable cast iron	130	262 - 394										
	20		230	230 - 361										

Note: Feed and speed recommendations are starting operating parameters. They are only guidelines from which further optimization should take place. Operating parameters are influenced by many machining variables. These variables may cause for reductions in feeds and speed or dramatic increases. Additionally, DOC and WOC may need to be revised to optimize the tools performance.



**COMPLETE  
METALWORKING  
SOLUTIONS**

(800) 991-4225

www.ahbinc.com  
ISO Certified  
customerservice@ahbinc.com