

T-BURST™

HIGH PRESSURE, COOLANT CAPABLE TURN/GROOVE & PARTING TOOLS

TOCLAMP^{ULTRA+}



GOLD FLEX



T-Burst: T-Clamp Ultra Plus Series

• Swiss Type Holders

- .375" NEW
- .500"
- .625"

• Traditional Holders

- .75"
- 1.00"

• Insert Widths

- 2mm (.079") NEW
- 3mm (.118")
- 4mm (.157")
- 5mm (.197")
- 6mm (.236")
- 8mm (.315")

T-Burst: GoldFlex Series

• Traditional Holders

- .500"
- 16mm (.630")
- .750"
- 1.00"

- Insert Widths: .5mm-3.18mm
(.020" - .125")

Compatible with High Pressure Systems -
Up to 4900 PSI

Coolant Hoses and Fittings also Available

**UPDATED
PRODUCT
ANNOUNCEMENT
2017**

NEW-219-5 (08/2017)

PAGE 1 OF 15

Member IMC Group
Ingersoll
Cutting Tools

AHB Tooling & Machinery, Inc.
ISO Certified
(800) 991-4225
www.ahbinc.com
customerservice@ahbinc.com
Complete Metalworking Solutions
Roseville Saginaw & Jackson, MI



High Pressure Coolant Capable Turn/Groove and Parting Tools

In order to meet the machining needs of difficult-to-cut materials such as titanium, inconel and other heat resistant alloys, Ingersoll is pleased to introduce the T-BURST series of high pressure, coolant-thru tools for turning, grooving and parting.

In difficult-to-cut materials it can be quite challenging to break chips in parting and grooving applications when applying external flood coolant, particularly in low feed rate applications. T-Burst holders apply a high pressure coolant stream directly to the insert's cutting edge, which improves chip breaking while significantly reducing build-up on the insert. This constant, directed stream of coolant also keeps the insert temperature more stable, meaning higher cutting speeds can be applied in order to reduce cycle times. The end result is longer and more stable tool life and higher productivity.

The T-BURST series of high pressure holders are available in three styles:

- TTER/L-TB (T-Clamp Ultra Plus, traditional style holders)
- TTER/L-SH-TB (T-Clamp Ultra Plus, Swiss style holders)
- TQHR/L (GoldFlex)

TTER/L-TB holders are available with .750" and 1.00" shanks and use inserts ranging in width from 2.0-8.0 mm (.079" - .315"). Maximum coolant pressure is 4350 PSI.

TTER/L-SH-TB holders are available with .375", .500" and .625" shanks and feature a side clamping design for fast and easy indexing on Swiss type tooling machines. These holders use any of our T-Clamp Ultra Plus inserts with seat size = 2 or 3. Maximum coolant pressure is 4900 PSI.

TQHR/L GoldFlex holders are available with .500", 16mm, .750" and 1.00" shanks and use any of our GoldFlex inserts (widths can range from .5mm to 3.18 mm (.020" - .125"). Maximum coolant pressure is 4350 PSI.

FEATURES

- **Excellent performance on difficult-to-cut materials such as titanium, inconel and other heat resistant alloys**
- **Good chip breaking on exotic materials under low feed rate conditions**
- **Very significant increase in tool life on heat resistant materials and stainless steels**
- **Reduced cycle time and higher productivity due to increased cutting speeds**
- **Maximum pressure: 4350 PSI: TTER/L-TB, TQHR/L-TB 4900 PSI: TTER/L-SH-TB**
- * **New TTER/L-SH-TB holder - with side clamping system for Swiss type and small CNC lathes**
 - **Insert mounting from both sides of the holder**
 - **Simplified insert clamping without removing the holder from the machine**
 - **Fast and easy mounting on Swiss type machines**

T-BURST™ COOLANT INLET LOCATION

With the coolant outlet located on the upper jaw, directly over the insert, effective coolant flow is supplied to the insert's cutting edge from the tool holder's internal coolant channel.

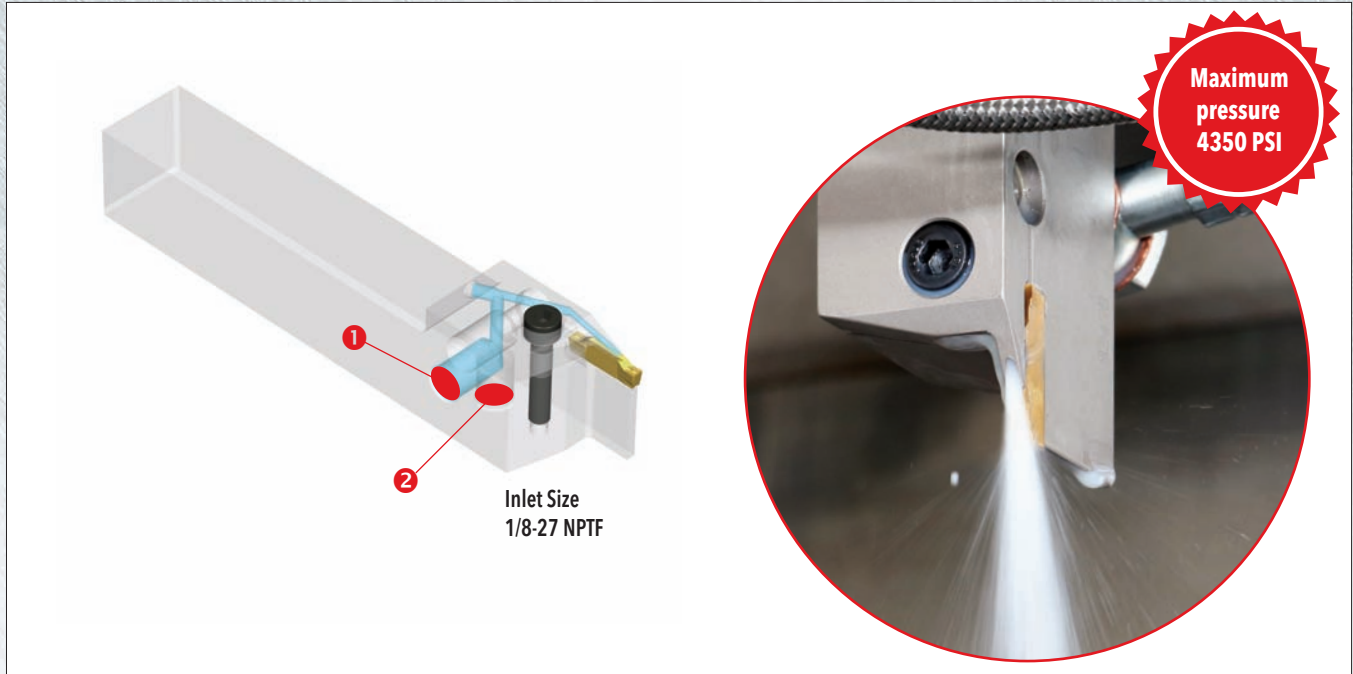

GoldFlex T-BURST holders are designed with three coolant inlets for adaptability to different machine types.

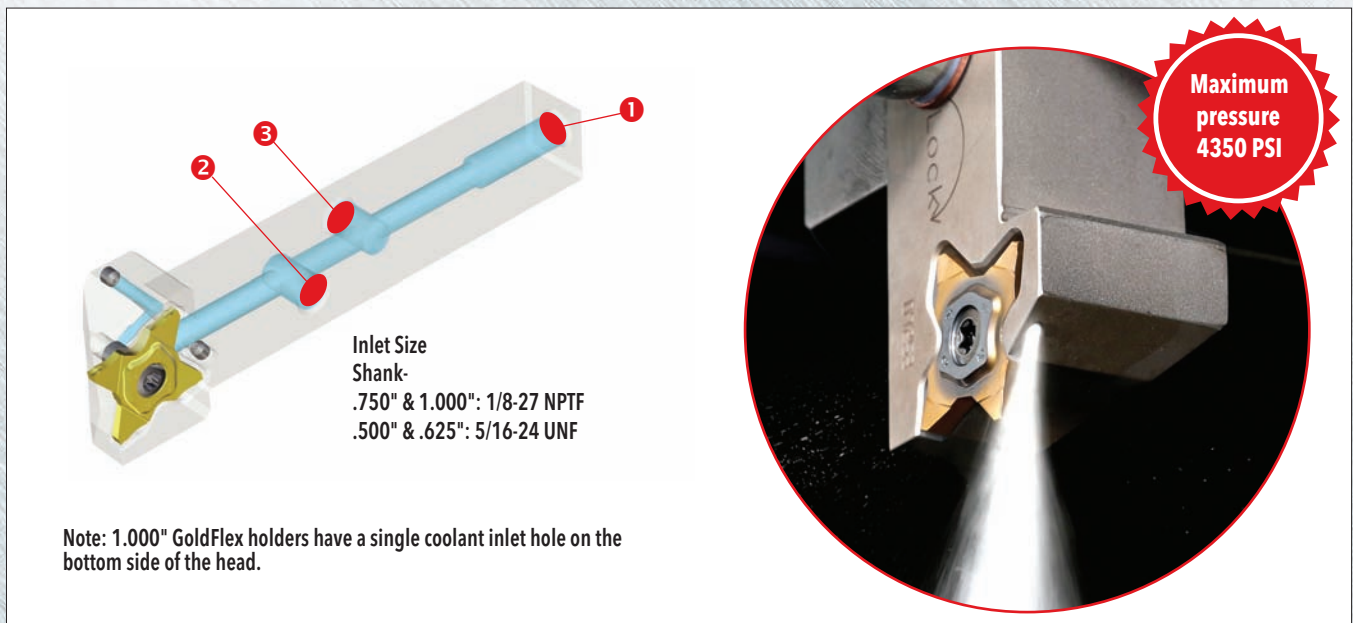

Note: 1.000" GoldFlex holders have a single coolant inlet hole on the bottom side of the head.

T_OBURST™ TTER/L-SH-TB FOR SWISS TYPE MACHINES

With the introduction of the innovative side clamping mechanism on the existing "SH" type holders combined with high-pressure coolant flow (maximum 4900 PSI) to the insert's cutting edge, insert mounting can now be done directly on the machine. No more holder removal from the tooling post. This is especially convenient on Swiss type lathes.

Three coolant inlets strategically located along the tool holder means adaptability to different machine types.

Conventional

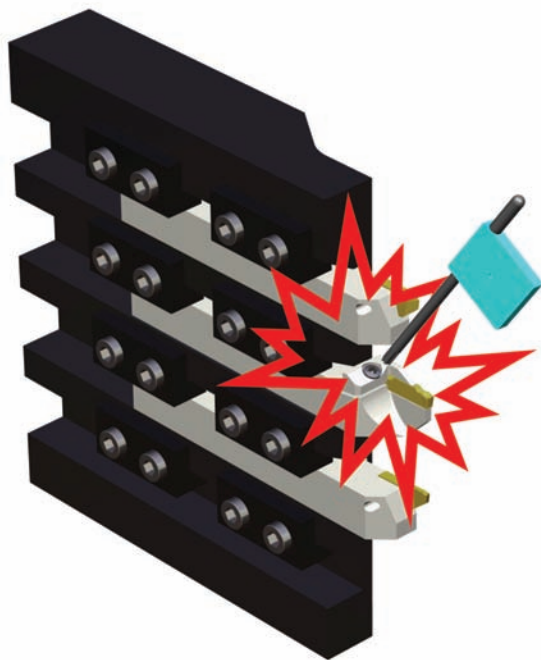

The minimal space on Swiss type machines makes indexing an awkward task with conventional screw clamping type holders.

Ingersoll new side clamping

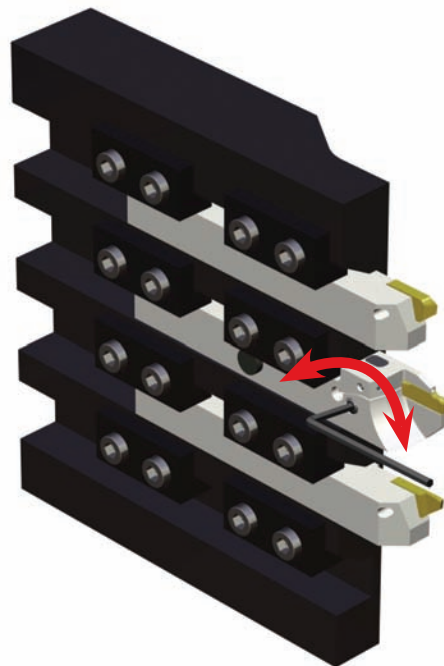

With Ingersoll's new side clamping design, trouble free insert indexing from either the left or right side of the holder eliminates tooling down time.

T₀BURST™ TTER/L-SH-TB FOR SWISS TYPE MACHINES

The tool holder is designed as a R/L holder. If the clamping screw is indexed on the left side, the pin plug is indexed on the right side to prevent chip entry. Indexing can also be done on the opposite side; if the clamping screw is indexed on the right side, the pin plug must be indexed on the left side.

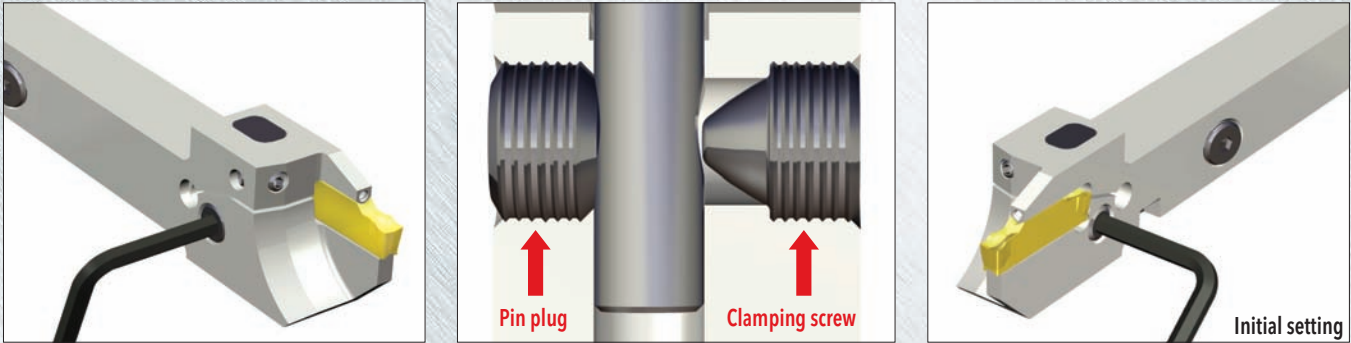

TTER/L-SH-TB assembly guide and coolant inlet location

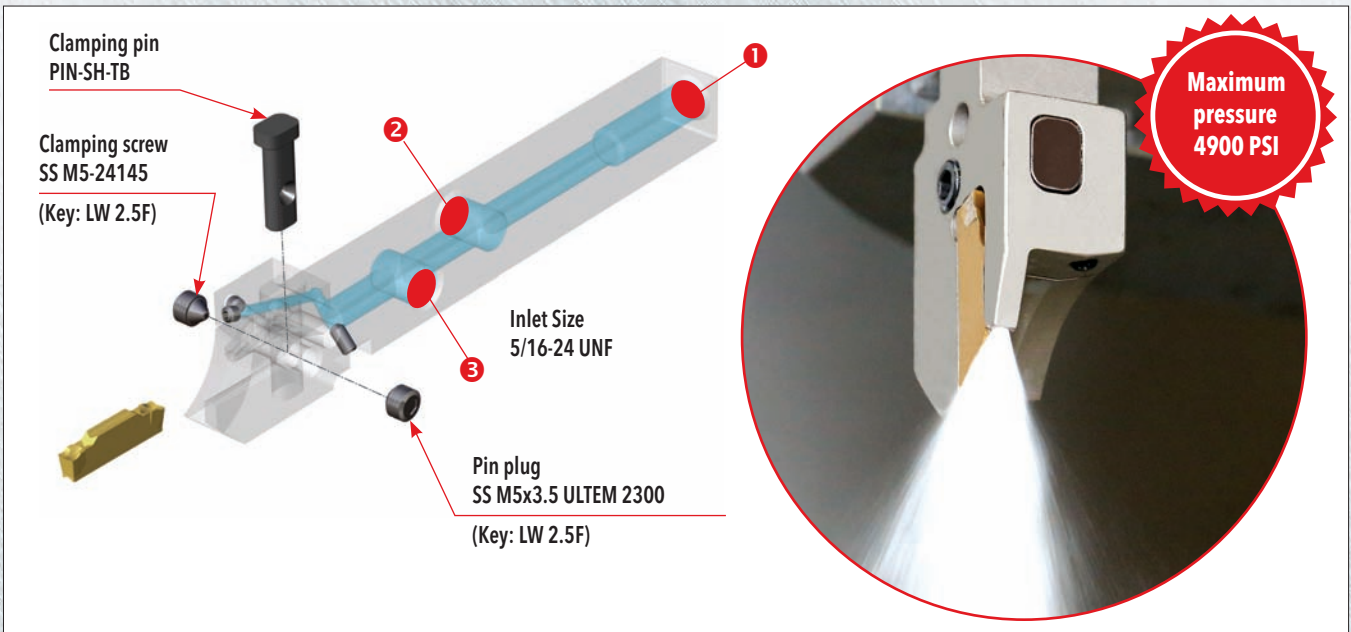

T-BURST™ CASE STUDY 1

Purpose	Chip breaking and tool life comparison
Material	Inconel 718
Tool	Normal vs T-BURST
Insert	TDJ 3 TT9080
Cutting condition	V=100 & 200 sfm, ap=.390", f=.003 ipr
Tool life (grooves)	V=100 Normal: 28 / T-BURST: 46
	V=200 Normal: 4 / T-BURST: 7

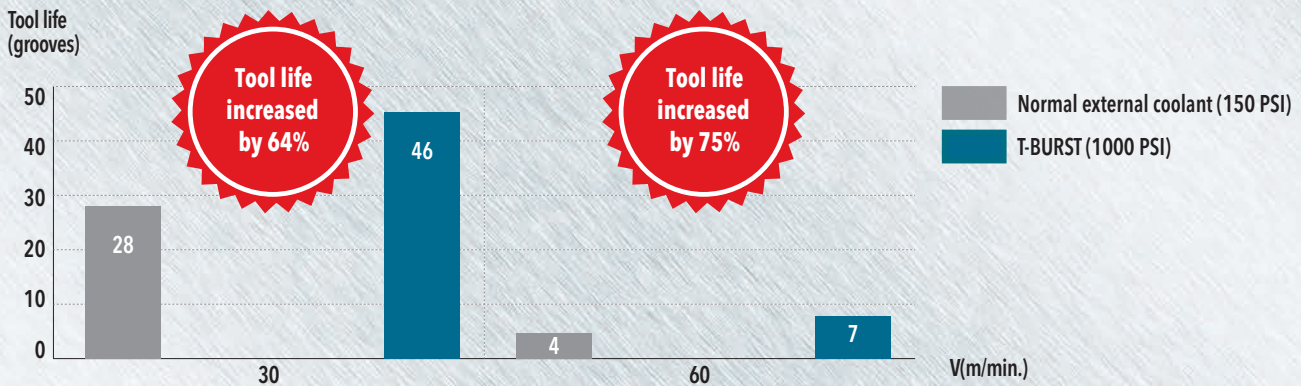

T-BURST™ CHIP BREAKING TEST

Between Normal external coolant & T-BURST

V=200 sfm, ap=.390"

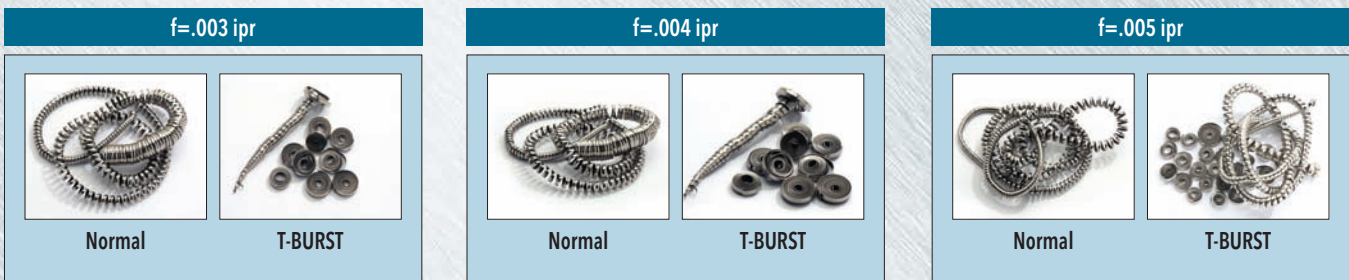

T₀BURST™ CASE STUDY 2

Purpose	Chip breaking and tool life comparison
Material	Titanium alloy (Ti6Al4V)
Tool	Normal vs T-BURST
Insert	TDXU 3E-0.3 K10
Cutting condition	V=200 sfm, ap=.390", f=.005 ipr
Tool life (grooves)	Normal: 35, T-BURST: 175

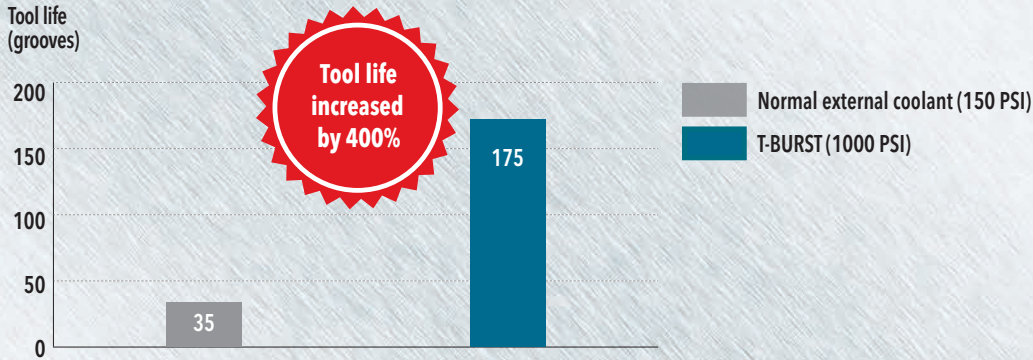

T₀BURST™ CHIP BREAKING TEST

Between Normal external coolant & T-BURST

V=200 sfm, ap=.390"



T-BURST™ CASE STUDY 3

Purpose	Chip breaking and tool life comparison
Material	Stainless steel (AISI 304)
Tool	Normal vs T-BURST
Insert	TDJ 3 TT9080
Cutting condition	V=650 sfm, ap=.390", f=.004 ipr
Tool life (grooves)	Normal: 205, T-BURST: 325

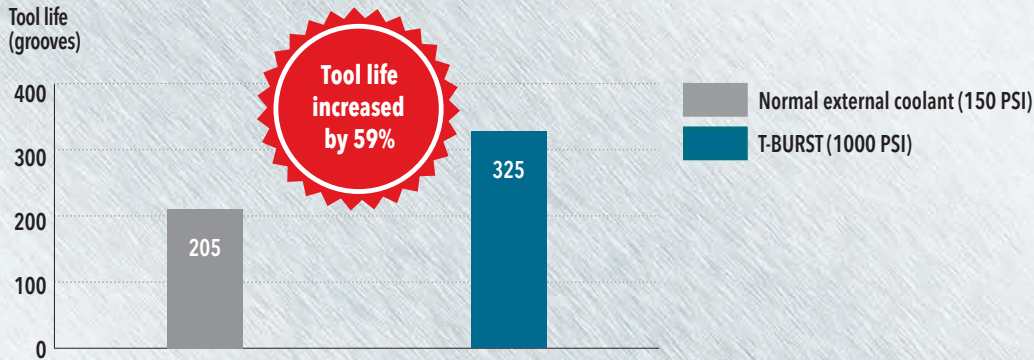

T-BURST™ CHIP BREAKING TEST

Between Normal external coolant & T-BURST

V=650 sfm, ap=.390"



T-BURST™ CASE STUDY 4

Purpose	Chip breaking and tool life comparison
Material	Aluminum alloy
Tool	Normal vs T-BURST
Insert	TDJ 3 K10
Cutting condition	V=2800 sfm, ap=.390", f=.006 ipr
Tool life (grooves)	Normal: 50, T-BURST: 450

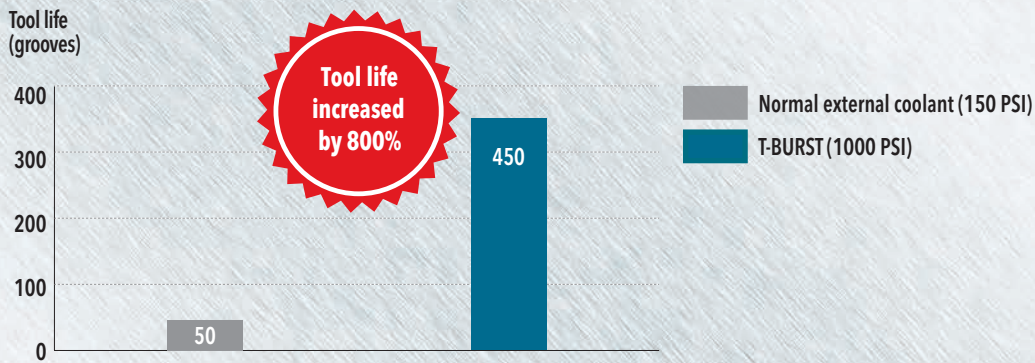

T-BURST™ CHIP BREAKING TEST

Between Normal external coolant & T-BURST

V=2800 sfm, ap=.390"

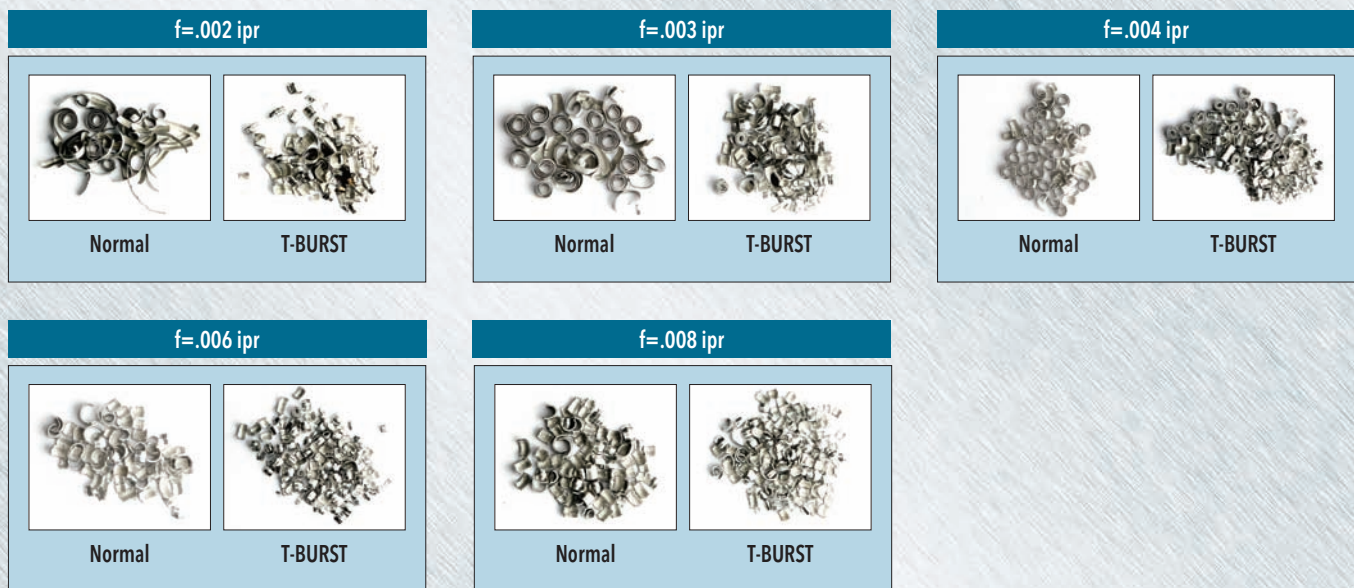

T-BURST™ CASE STUDY 5 - GOLDFLEX

Purpose	Chip breaking and tool life comparison
Material	Stainless steel (AISI 304)
Tool	Normal vs T-BURST
Insert	TQJ 27-3.00-0.20 TT9080
Cutting condition	V=980 sfm, ap=.200", f=.003 ipr
Tool life (grooves)	Normal: 75, T-BURST: 210

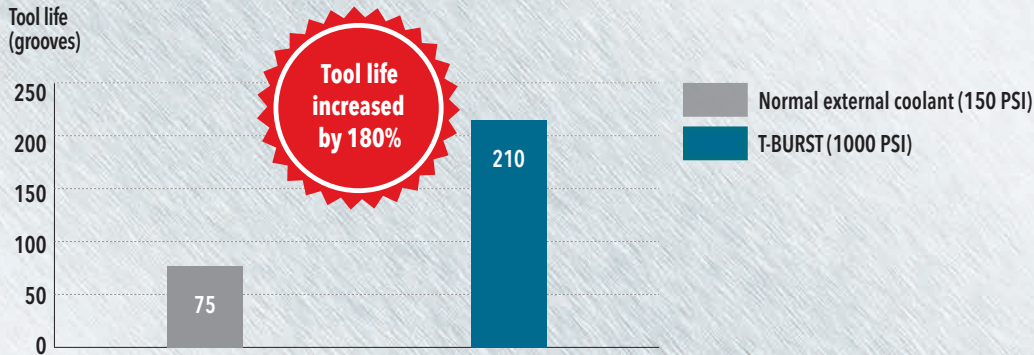

T-BURST™ CHIP BREAKING TEST

Between Normal external coolant & T-BURST

V=980 sfm, ap=.200"

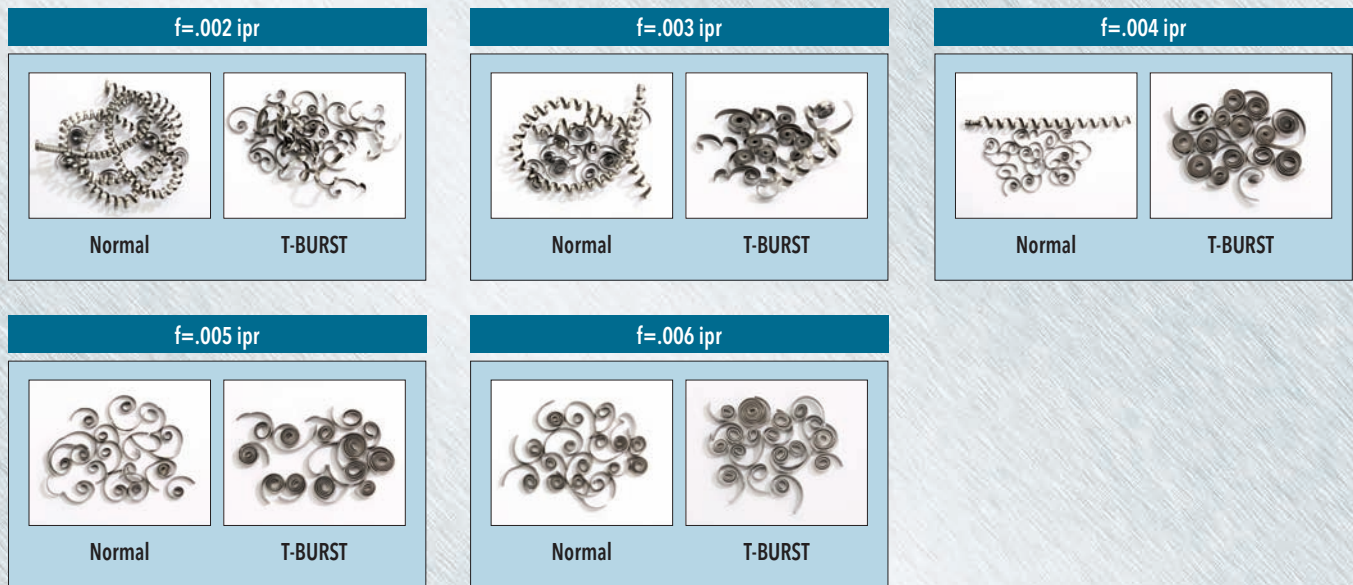

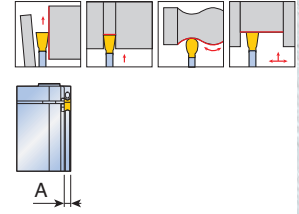
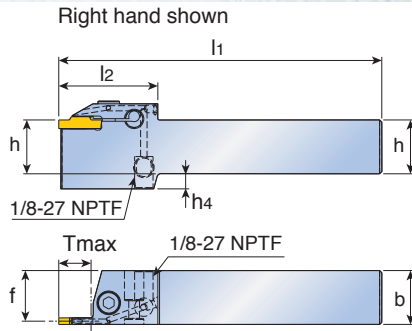
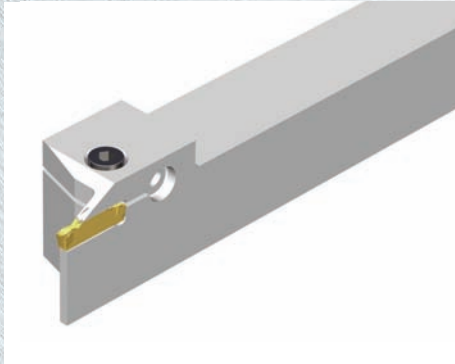

Designation	Insert seat size	Dimension (inch)								Torque (in-lbs)	Insert
		h	b	l1	f	l2	A	h4	Tmax		
NEW TTER/L19-2T12-TB	2	0.75	0.75	5.0	0.715	1.69	0.071	0.157	0.472	48	TDC / J / T / A TDXU / XT TSC / J / A
NEW TTER/L 25.4-2T12-TB	2	1.00	1.00	6.0	0.965	1.69	0.071	0.157	0.472	48	
TTTER/L 19-3-TB	3	0.75	0.75	5.0	0.703	1.69	0.094	0.157	0.472	48	
TTTER/L 25.4-3-TB	3	1.00	1.00	6.0	0.953	1.69	0.094	0.157	0.472	48	
TTTER/L 25.4-3T25-TB	3	1.00	1.00	6.0	0.953	2.01	0.094	0.157	0.984	48	
TTTER/L 19-4-TB	4	0.75	0.75	5.0	0.691	1.81	0.118	0.157	0.591	70	
TTTER/L 25.4-4-TB	4	1.00	1.00	6.0	0.941	1.81	0.118	0.157	0.591	70	
TTTER/L 25.4-4T25-TB	4	1.00	1.00	6.0	0.941	2.17	0.118	0.157	0.984	70	
TTTER/L 25.4-5-TB	5	1.00	1.00	6.0	0.925	1.93	0.157	-	0.787	70	
TTTER/L 25.4-5T32-TB	5	1.00	1.00	6.0	0.925	2.32	0.157	-	1.260	70	
TTTER/L 25.4-6-TB	6	1.00	1.00	6.0	0.906	2.05	0.197	0.276	0.787	106	
TTTER/L 25.4-6T32-TB	6	1.00	1.00	6.0	0.906	2.44	0.197	0.197	1.260	106	
TTTER/L 25.4-8-TB	8	1.00	1.00	6.0	0.886	2.28	0.236	0.276	0.787	106	

Designation	1000 psi Flow Rate (gallons/min)	1500 psi Flow Rate (gallons/min)	2000 psi Flow Rate (gallons/min)
TTTER/L19-2T12-TB	1.3-1.8	1.8-2.4	2.1-2.6
TTTER/L 25.4-2T12-TB	1.3-1.8	1.8-2.4	2.1-2.6
TTTER/L 19-3-TB	1.3-1.8	1.8-2.4	2.4-2.9
TTTER/L 25.4-3-TB	1.6-2.1	2.6-3.2	3.2-3.7
TTTER/L 25.4-3T25-TB	1.6-2.1	2.6-3.2	3.2-3.7
TTTER/L 19-4-TB	1.6-2.1	2.1-2.6	2.6-3.2
TTTER/L 25.4-4-TB	2.6-3.2	3.7-4.2	4.2-4.8
TTTER/L 25.4-4T25-TB	2.6-3.2	3.7-4.2	4.2-4.8
TTTER/L 25.4-5-TB	3.4-4.2	5.0-5.5	5.8-6.3
TTTER/L 25.4-5T32-TB	3.4-4.2	5.0-5.5	5.8-6.3
TTTER/L 25.4-6-TB	3.4-4.2	5.0-5.5	5.8-6.3
TTTER/L 25.4-6T32-TB	3.4-4.2	5.0-5.5	5.8-6.3
TTTER/L 25.4-8-TB	3.4-4.2	5.0-5.5	5.8-6.3

SPARE PARTS

Designation	Screw	Wrench	Sealing Screw	Plug	Wrench for plug
TTTER/L19-2T12-TB	SH M5X0.8X20	L-W4	SS M4X0.7X4	NPTF 1/8	L-W3/16
TTTER/L 25.4-2T12-TB					
TTTER/L 19-3-TB					
TTTER/L 25.4-3-TB					
TTTER/L 25.4-3T25-TB					
TTTER/L 19-4-TB	SH M6X1.0X20	L-W5	SS M4X0.7X4	NPTF 1/8	L-W3/16
TTTER/L 25.4-4-TB					
TTTER/L 25.4-4T25-TB					
TTTER/L 25.4-5-TB					
TTTER/L 25.4-5T32-TB	SH M8X1.25X20	L-W6	SS M4X0.7X4	NPTF 1/8	L-W3/16
TTTER/L 25.4-6-TB					
TTTER/L 25.4-6T32-TB					
TTTER/L 25.4-8-TB					

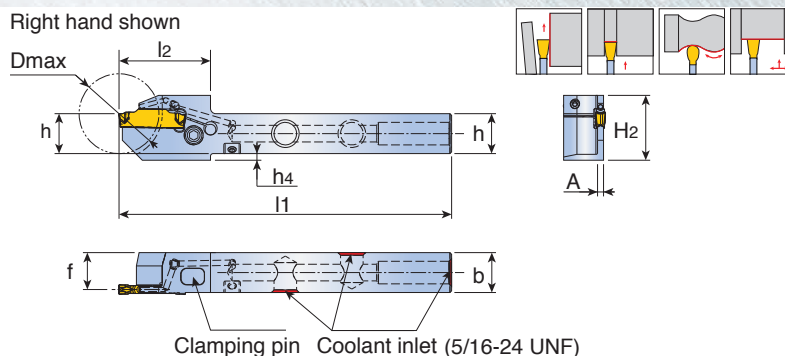

Designation	Insert seat size	Dimension (inch)										Insert
		h	b	l1	f	l2	A	h4	H2	Dmax		
NEW TTER/L 9.5-20-2SH-TB	2	0.375	0.375	5.0	0.438	1.06	0.071	0.098	0.690	0.787	TDC / J / T TDXU / XT TSC / J	
NEW TTER/L 12.7-24-2SH-TB	2	0.500	0.500	5.0	0.465	1.06	0.071	0.079	0.776	0.945		
NEW TTER/L 15.9-32-2SH-TB	2	0.625	0.625	5.0	0.590	1.22	0.071	-	0.822	1.260		
TTTER/L 12.7-24-3SH-TB	3	0.500	0.500	5.0	0.453	1.08	0.094	0.079	0.795	0.945		
TTTER/L 15.9-32-3SH-TB	3	0.625	0.625	5.0	0.579	1.24	0.094	-	0.843	1.260		

Designation	1000 psi Flow Rate (gallons/min)	1500 psi Flow Rate (gallons/min)	2000 psi Flow Rate (gallons/min)
TTTER/L 9.5-20-2SH-TB	1.3	1.8	2.1
TTTER/L 12.7-24-2SH-TB	1.3	1.8	2.1
TTTER/L 15.9-32-2SH-TB	1.3	1.8	2.1
TTTER/L 12.7-24-3SH-TB	1.7	2.6	3.1
TTTER/L 15.9-32-3SH-TB	1.7	2.6	3.1

SPARE PARTS

Designation	Clamping Pin	Clamping Screw	Pin Plug	Wrench	Inlet Plug	Wrench for Inlet Plug
TTTER/L 9.5-20-2SH-TB	PIN-SH-TB-L21	SS M5-24145	SS M5X3.5 ULTEM 2300	L-W 2.5F	PLG 5/16 UNF-MO	L-W 5/32"
TTTER/L 12.7-24-2SH-TB	PIN-SH-TB-L21	SS M5-24145	SS M5X3.5 ULTEM 2300	L-W 2.5F	PLG 5/16 UNF	L-W 5/32"
TTTER/L 15.9-32-2SH-TB	PIN-SH-TB-L21	SS M5-24145	SS M5X3.5 ULTEM 2300	L-W 2.5F	PLG 5/16 UNF	L-W 5/32"
TTTER/L 12.7-24-3SH-TB	PIN-SH-TB	SS M5-24145	SS M5X3.5 ULTEM 2300	L-W 2.5F	PLG 5/16 UNF	L-W 5/32"
TTTER/L 15.9-32-3SH-TB	PIN-SH-TB	SS M5-24145	SS M5X3.5 ULTEM 2300	L-W 2.5F	PLG 5/16 UNF	L-W 5/32"

GOLD FLEX TQHR/L-TB EXTERNAL GROOVING AND TURNING HOLDERS FOR HIGH PRESSURE COOLANT

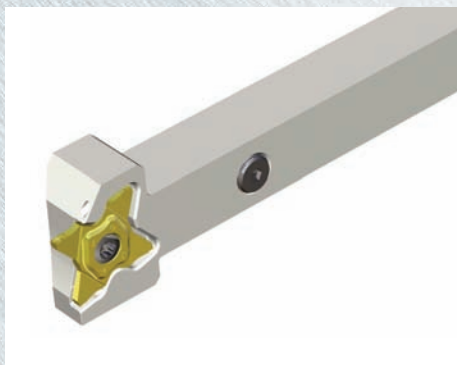

Right hand shown

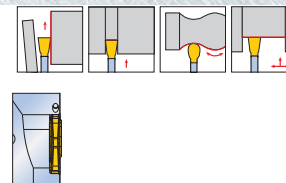
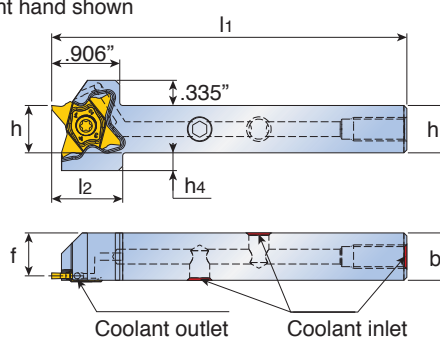

Designation	Dimension (inch)						Coolant Inlet	Insert
	h	b	l1	f	l2	h4		
TQHR/L 12.7-27-TB	0.500	0.500	5.00	0.441	0.944	0.287	UNF 5/16-24	TQJ27 TQC27 TQS27
TQHR/L 16-27-TB	0.630 (16mm)	0.630 (16mm)	4.72	0.571	0.944	0.236	UNF 5/16-24	
TQHR/L 19-27-TB	0.750	0.750	5.00	0.691	0.944	0.118	1/8-27 NPTF	
TQHR/L 25.4-27-TB	1.000	1.000	5.50	0.941	-	-	1/8-27 NPTF	

Designation	1000 psi Flow Rate (gallons/min)	1500 psi Flow Rate (gallons/min)	2000 psi Flow Rate (gallons/min)
TQHR/L-TB	2.4-2.9	2.9-3.4	3.2-3.7

SPARE PARTS

Designation	Screw	Wrench	Inlet Plug	Wrench for Inlet Plug
TQHR/L 12.7-27-TB				
TQHR/L 16-27-TB	SM50-125-60 ⁽¹⁾	T-2010/5	PT 5/16 UNF	L-W 4
TQHR/L 19-27-TB	SM50-125L60 ⁽²⁾		PT 5/16 UNF	L-W 5/32"
TQHR/L 25.4-27-TB			NPTF 1/8-TQ19	L-W 5
			NPTF 1/8-TQ19	L-W 5

• ⁽¹⁾ For TQHL • ⁽²⁾ For TQHR

T_OBURST™ ACCESSORIES

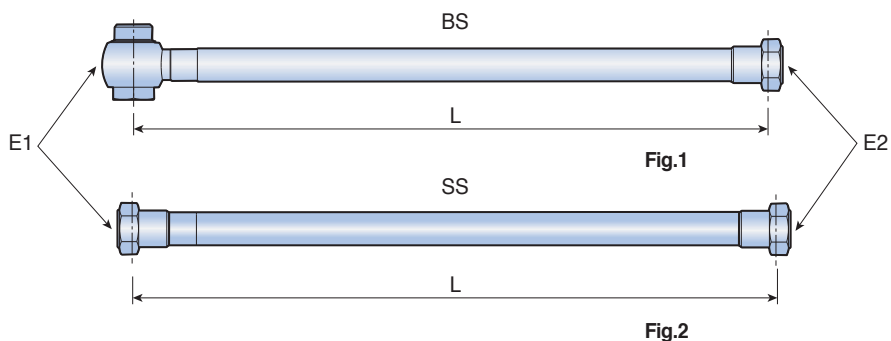

HOSE

Designation	L	Dimension		Max Pressure (psi)	Fig.
		E1	E2		
TB-HOSE-5/16-7/16-200BS*	8.0 inch	5/16-24 UNF	1/4 (37° Flare)	2900	1
TB-HOSE-7/16-7/16-8.0SS	8.0 inch	1/4 (37° Flare)	1/4 (37° Flare)	3000	2
TB-HOSE-7/16-7/16-10.0SS	10.0 inch	1/4 (37° Flare)	1/4 (37° Flare)	3000	2

Note: Hoses ordered separately.

* Includes 2 seal washers for E1 end.

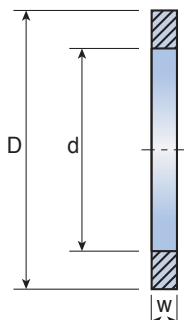

SEAL WASHER

Designation	Dimension (mm)		
	D	d	w
TB COPPER SEAL-5/16*	12	8	1

Note: Seal washer ordered separately.

* For use with TB-HOSE-5/16-7/16 200BS.

T_OBURST™ ACCESSORIES

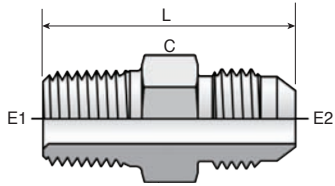

Fig.1

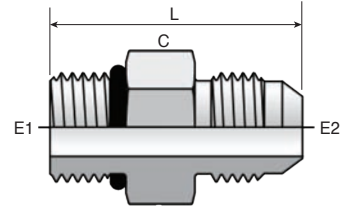

Fig.2

MALE CONNECTOR - STRAIGHT

Designation	End Size		C (hex)	L	Max Pressure (psi)	Fig.
	E1	E2				
TB-4-FTX-S	1/8-27 NPTF	1/4 (37° Flare)	1/2"	1.22"	6000	1
TB-4-2-F50X-S*	5/16-24 UNF	1/4 (37° Flare)	9/16"	1.17"	7500	2

* Not compatible with .375" shank holders

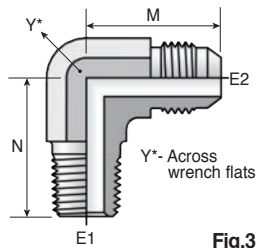

Fig.3

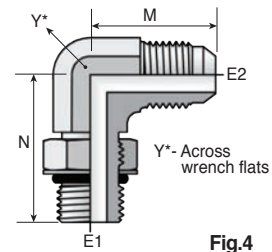

Fig.4

MALE CONNECTOR - ELBOW

Designation	End Size		Y	M	N	Max Pressure (psi)	Fig.
	E1	E2					
TB-4-CTX-S	1/8-27 NPTF	1/4 (37° Flare)	7/16"	0.89"	0.78"	6000	3
TB-4-2-C50X-S	5/16-24 UNF	1/4 (37° Flare)	7/16"	0.89"	0.92"	5000	4

Note: All connectors ordered separately.