





TCLAMP™

PARTING & GROOVING PRODUCTS



Square Shank Sizes:
 Parallel & Perpendicular
 .750, 1.00, 1.25"
 .750, 1.00, 1.25" - TB 

C-Adapter Sizes:
 Parallel & Perpendicular
 C4-C5-C6
 C4-C5-C6 - TB 

Cartridges:
 Parting & Grooving
 TCAER/L (1.4-2-3-4-5-6-8mm)
 TCAER/L-TB (2-3-4-5mm) 

Face Grooving:
 TCAFR/L (3-4-5-6mm)

GoldFlex:
 TQCR/L (20, 27, 34)
 TQCR/L-TB (20 & 27) 

New Modular Parting & Groove-Turning System - With and Without High Pressure Coolant

The new modular system is capable of being correctly fitted to parallel, perpendicular holders as well as C-Adapters.

With a wedge designed tightening structure, the new cartridge prevents vibrations during machining and ensures highly reliable performance with increased holder stiffness. High pressure coolant is sprayed directly to the cutting edge through the upper and lower channels, which increases the tool life and facilitates chip evacuation during machining operations.

Features & Benefits:

- Flexible solution for parting, grooving, groove-turning, and face grooving applications
- Unique wedge designed tightening structure prevents vibration and increases holder stiffness
- 8-35% increased rigidity compared to old modular system
- Increased tool life and good chip evacuation due to high pressure coolant supply to cutting edge from upper and lower channels
- On/Off sealing screw for both upper and lower coolant channels

AHB

TOOLING & MACHINERY

COMPLETE METALWORKING SOLUTIONS
 (800) 991-4225
 ISO Certified

www.ahbinc.com
 customerservice@ahbinc.com

Industry 4.0 Member IMC Group
Ingersoll
 Cutting Tools

TCLAMP™ FEATURES

- Unique clamping mechanism improves rigidity and prevents chattering
- Compatible with parallel and perpendicular type holders and C-Adapters
- Applicable to T-Clamp and GoldFlex products

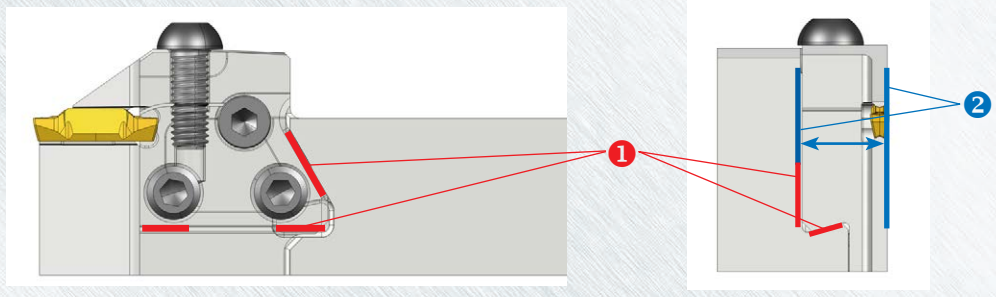

- ❶ The two way, anti-rotation wedge design is ideal for parting, grooving and turning operations
- ❷ Increased cartridge thickness for improved stiffness during operation

TCLAMP™ CARTRIDGE ASSEMBLY SEQUENCE

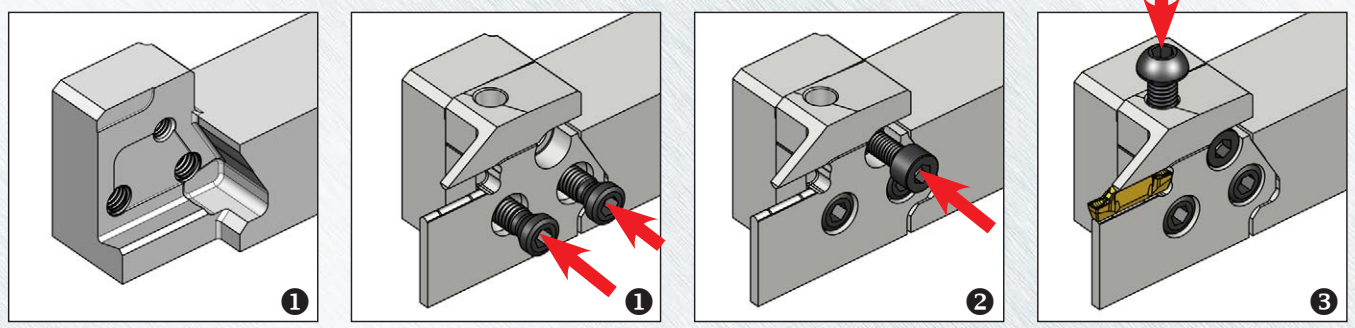

- ❶ Install the cartridge and tighten the 2 offset screws
- ❷ Tighten the security screw
- ❸ Tighten the insert with the screw

Not following the above instructions sequentially ❷ ⇒ ❶ may impair tool performance.

COOLBURST™ FEATURES

- Increased tool life and good chip evacuation due to the high pressure coolant supply to the cutting edge from the upper and lower channels
- Available in parallel holders, perpendicular holders and C-Adapters
- On/Off sealing screw for both the upper and lower coolant channels means the use with or without coolant
- New cartridge is compatible with the T-Clamp and GoldFlex lines

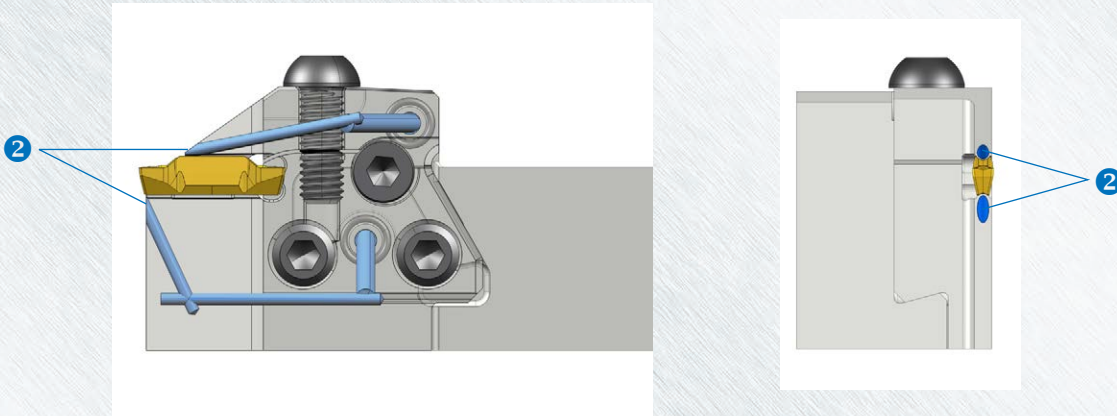

② Upper and lower channels

COOLBURST™ CARTRIDGE ASSEMBLY SEQUENCE

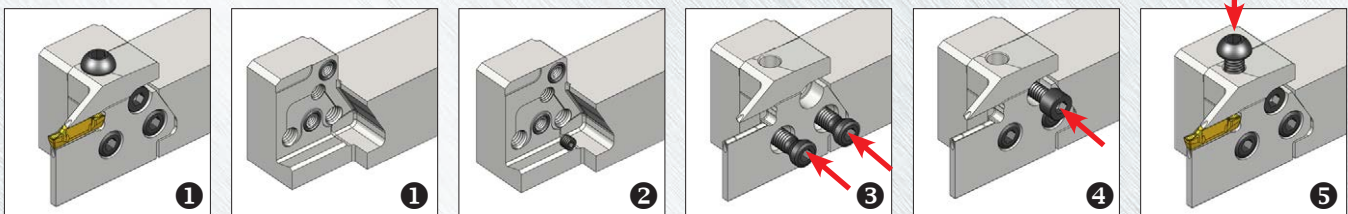

- ① Loosen the 3 screws and position the O-ring in place.
- ② The lower coolant On/Off sealing screw enables the coolant supply.
- For the C-Adapter, seal the unused pockets with an On/Off sealing screw.
- ③ Install the cartridge and tighten the 2 offset screws.
- ④ Tighten the security screw.
- ⑤ Tighten the insert with the screw.

Not following the above instructions sequentially ④ ⇒ ③ may impair tool performance.



COOLBURST™ CARTRIDGE ASSEMBLY STRUCTURE

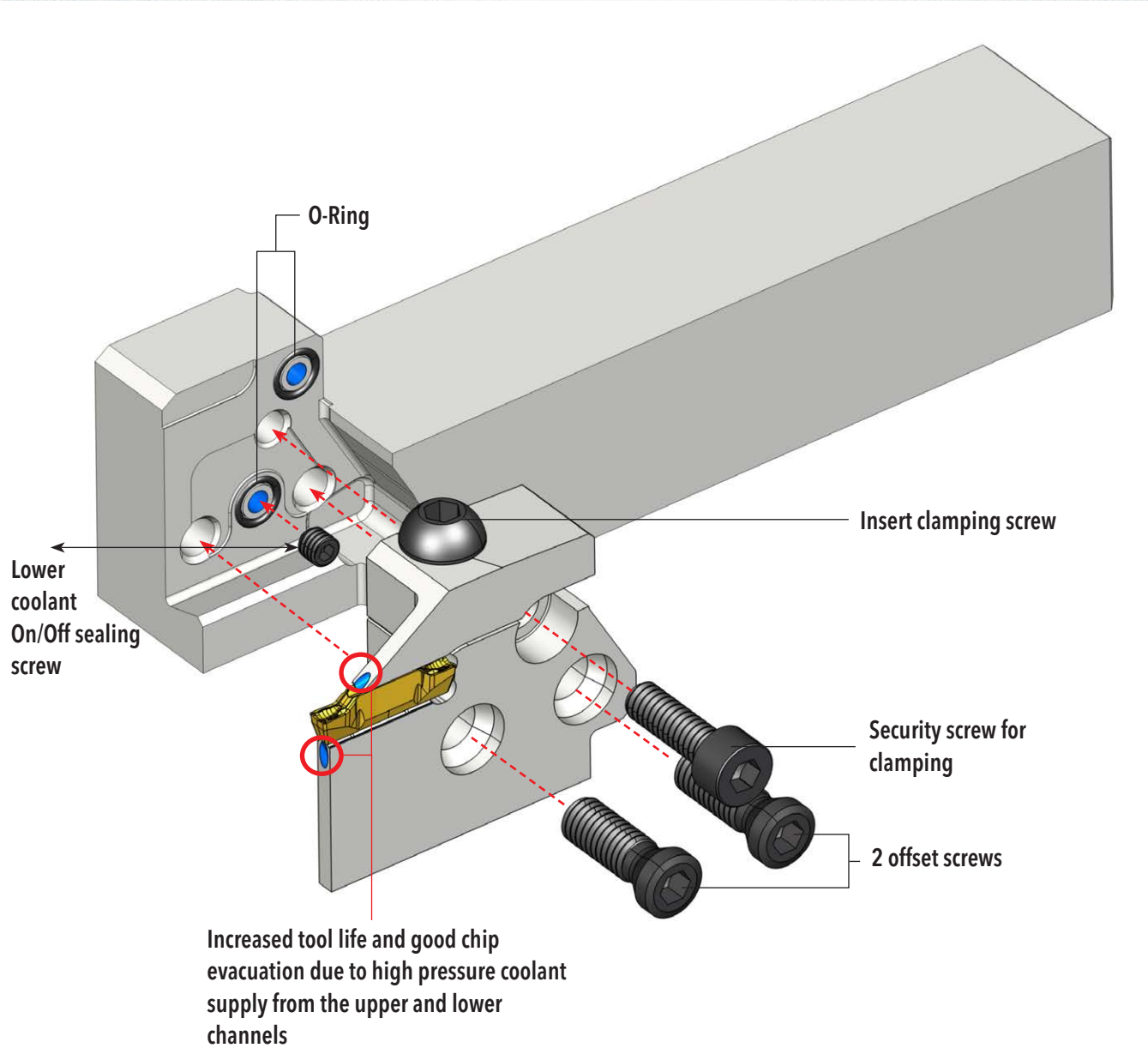



COOLBURST™ C-TCAHN-TB (PARALLEL TYPE)

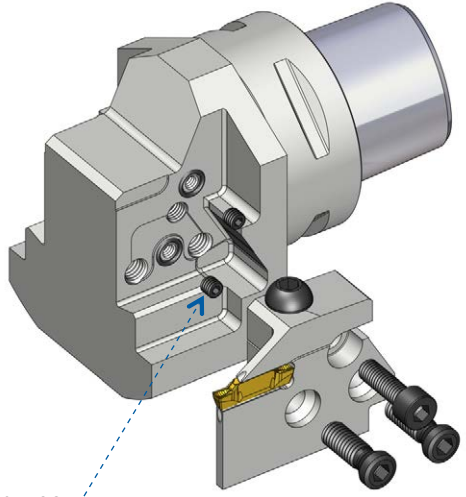

Part in use
The upper and lower coolant On/off sealing screws enable the selection of the coolant supply.

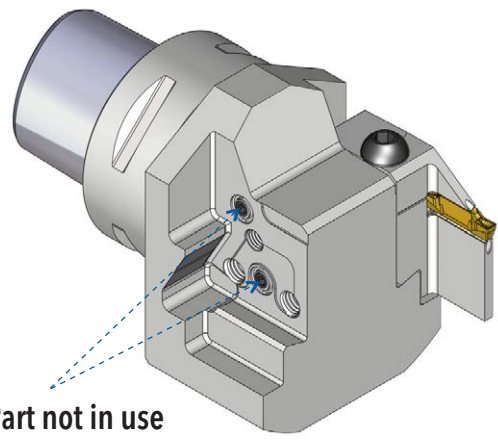

Part not in use
Please lock the On/off sealing screw for the part of the adapter not in use.

COOLBURST™ C-TCAHPN-TB (PERPENDICULAR TYPE)

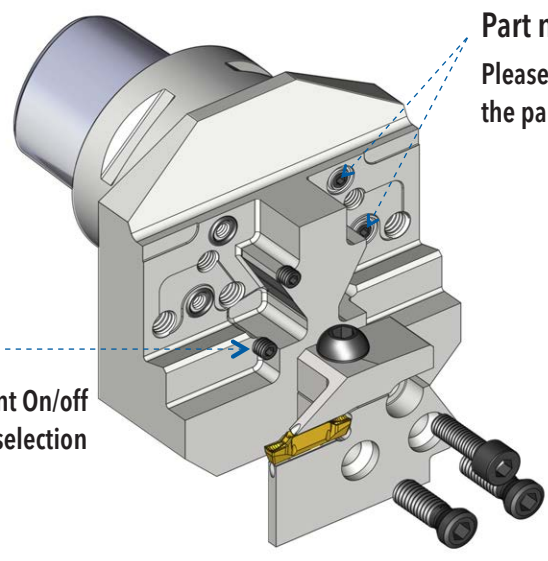















Part in use
The upper and lower coolant On/off sealing screws enable the selection of the coolant supply.

Part not in use
Please lock the On/off sealing screw for the part of the adapter not in use.

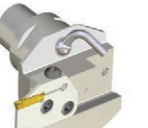

TCLAMP™ PHASE OUT

Due to the increased overall performance of the new modular system, the current modular system will be phased out over time.

		Phased out items	Replacements
Cartridge	External grooving	TCER/L 	TCAER/L 
	External face grooving	TCFR/L 	TCAFR/L 
	GoldFlex	TQCR/L 	TCAQR/L 
Holder	Parallel type	TCHR/L 	TCAHR/L 
	Perpendicular type	TCHPR/L 	TCAHPR/L 
C-Adapter	Parallel type	C4-TCHN 	C4-TCAHN 
	Perpendicular type	C4-TCHPN 	C4-TCAHPN 



TCLAMP™ CASE STUDIES

		Ingersoll	
Workpiece material		Alloy steel (AISI 4140)	
Application		Face grooving	
Cartridge		TCFR 3T12 75-100 RN	TCAFR 3T12 75-100 RN
Shank		TCHL 25.4	TCAHL 25.4
Insert		TDJ 3 TT9080	
Cutting speed	V (sfm)	330	
Feed rate	f (ipr)	.003	
Depth of cut	ap (inch)	.34	
Coolant		Wet	
Tool life (pcs/corner)		40	80

Tool life (pcs/corner)

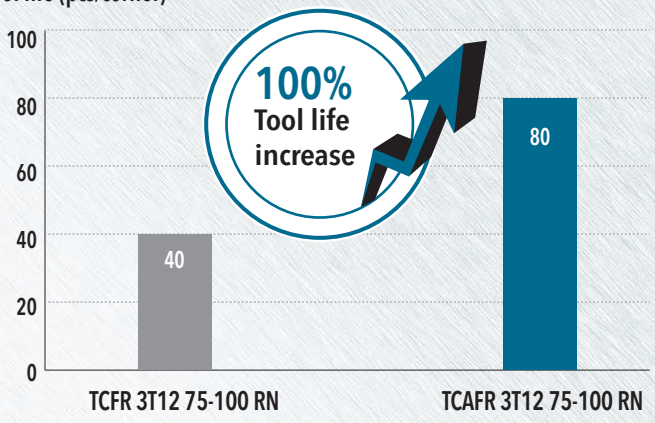

		Ingersoll	
Workpiece material		Stainless steel (AISI 304)	
Application		External grooving	
Holder		TTER 25.4-3	TCAER 3T16 + TCAHR 25.4
Insert		TDJ 3 TT9080	
Cutting speed	V (sfm)	390	
Feed rate	f (ipr)	.003	
Depth of cut	ap (inch)	.47	
Coolant		Wet	
Tool life (pcs/corner)		100	100

Tool life (pcs/corner)

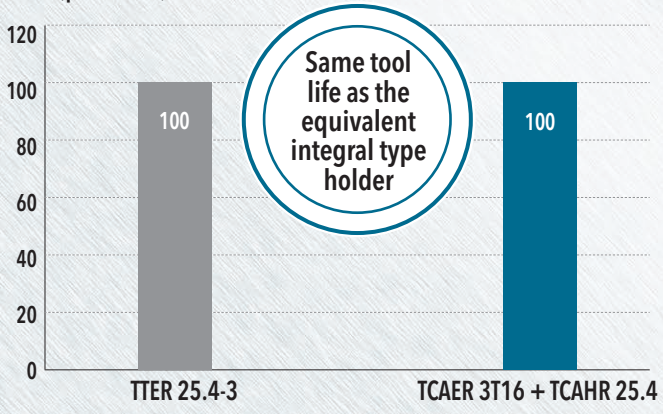



COOLBURST™ CASE STUDIES





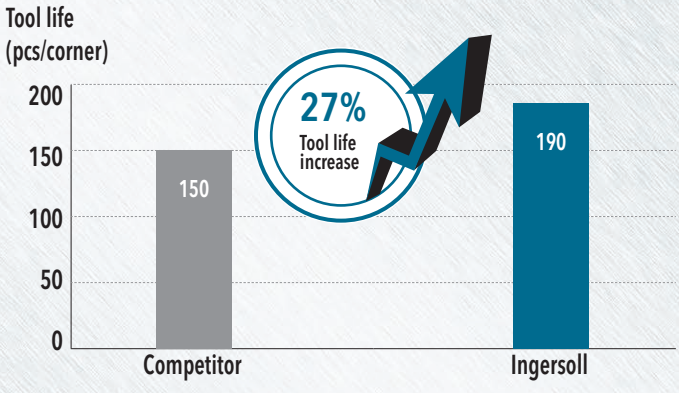



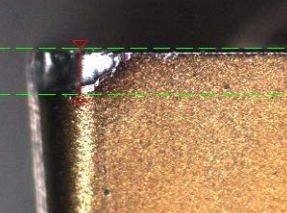

		Competitor	Ingersoll
Material		Alloy steel	
Blade		Cartridge type	TCAER 3T16-TB
Insert		Double ended insert	TDJ 3 TT9080
Cutting speed	V (sfm)	330	330
Feed rate	f (ipr)	.003	.003
Depth of cut	ap (inch)	.34	.34
Coolant pressure (bar)		10 (External coolant)	10 (Internal coolant)
Tool life (pcs/corner)		Unstable & chattering	80

		Competitor	Ingersoll
Material		Stainless steel (AISI 304)	
Blade		Cartridge type	TCAER 3T16-TB
Insert		Double ended insert	TDJ 3 TT9080
Cutting speed	V (sfm)	490	490
Feed rate	f (ipr)	.003	.003
Depth of cut	ap (inch)	.47	.47
Coolant pressure (bar)		70 (External high pressure coolant)	70 (Internal high pressure coolant)
Tool life (pcs/corner)		150	190





COOLBURST™ TOOL LIFE & CHIP CONTROL TEST (1 CHANNEL VS 2 CHANNELS)

		1 channel			2 channel		
Material		Stainless steel (AISI 304)					
Operation		External grooving					
Cutting speed	V (sfm)	650					
Feed rate	f (ipr)	.003					
Depth of cut	ap (inch)	.63					
Coolant		145 psi, 507 psi, 1015 psi (Internal)					
Tool life (pass/corner)		41, 51, 91			55, 75, 98		
Holder							
Insert wear		 1015 psi			 1015 psi		
Chip curl (1015 psi)		.003 ipr	.004 ipr	.005 ipr	.003 ipr	.004 ipr	.005 ipr
							

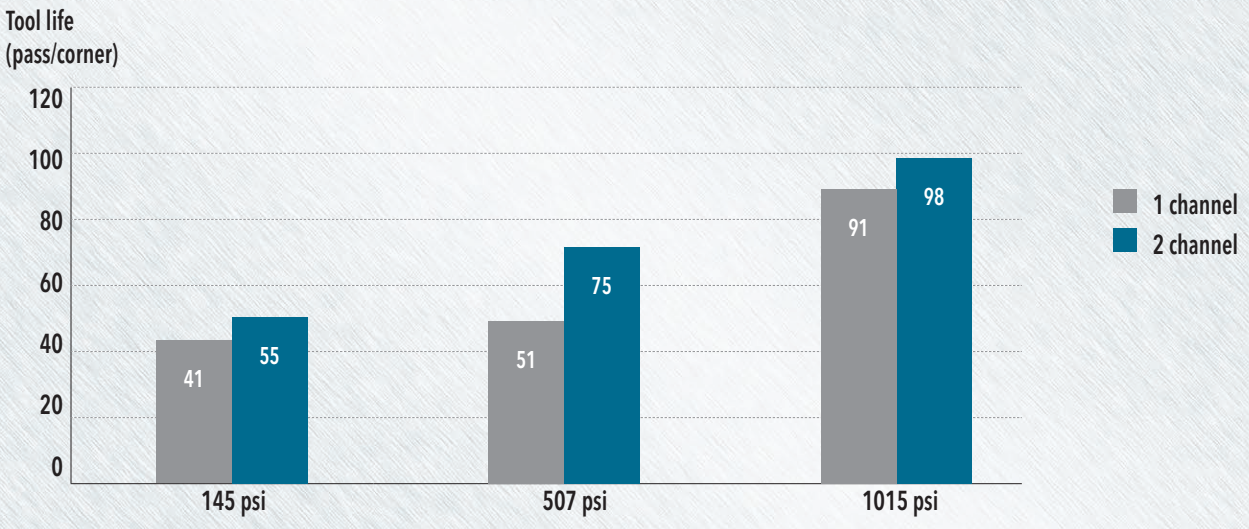



TCLAMP™ TCAHR/L PARALLEL TYPE HOLDERS FOR CARTRIDGE

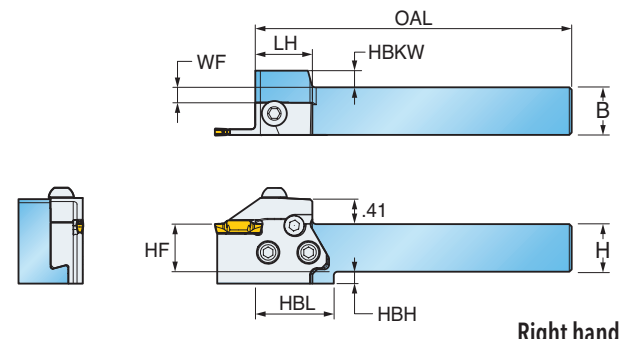

Right hand shown

Part Number	Dimension (inch)									Cartridge
	H Shank Height	HF Functional Height	B Shank Width	OAL Overall Length	WF Functional Width	HBH Head Bottom Offset Height	HBL Head Bottom Offset Length	HBKW Head Back Offset Width	LH Head Length	
TCAHR/L 19	.750	.750	.750	5.33	.22	.23	1.30	.31	-	TCAER/L
TCAHR/L 25.4	1.000	1.000	1.000	5.33	.45	-	-	.06	.94	TCAFL/R
TCAHR/L 31.8	1.250	1.250	1.250	6.33	.728	-	-	-	.94	TCAQR/L

• Cartridge should be ordered separately

Spare Parts

Part Number	Screw	Security Screw	Wrench			
TCAHR/L	TS 60190I	SH M5X0.8X16	L-W 4			



COOLBURST™ TCAHR/L-TB PARALLEL TYPE HOLDERS FOR CARTRIDGE W/ HIGH PRESSURE COOLANT

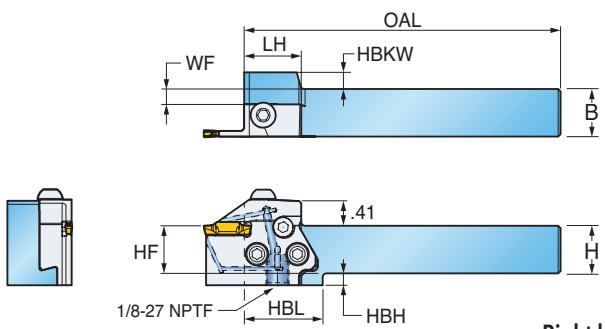

Right hand shown

Part Number	Dimension (inch)								Cartridge
	H Shank Height	HF Functional Height	B Shank Width	OAL Overall Length	WF Functional Width	HBH Head Bottom Offset Height	HBKW Head Back Offset Width	LH Head Length	
TCAHR/L 19-TB	.750	.750	.750	5.33	.22	.23	.31	.94	TCAER/L-TB TCAQR/L-TB
TCAHR/L 25.4-TB	1.000	1.000	1.000	5.33	.45	-	.06	-	
TCAHR/L 31.8-TB	1.250	1.250	1.250	6.33	-	-	-	-	

• Cartridge should be ordered separately

Spare Parts

Part Number	Screw	Security Screw	Sealing Screw	O-Ring	Wrench	
TCAHR/L-TB	TS 60190I	SH M5X0.8X16	SS M4X0.7X4-NL	O-RING ID5X1T	L-W 4	L-W 2



TCLAMP™ TCAHPR/L PERPENDICULAR TYPE HOLDERS FOR CARTRIDGE

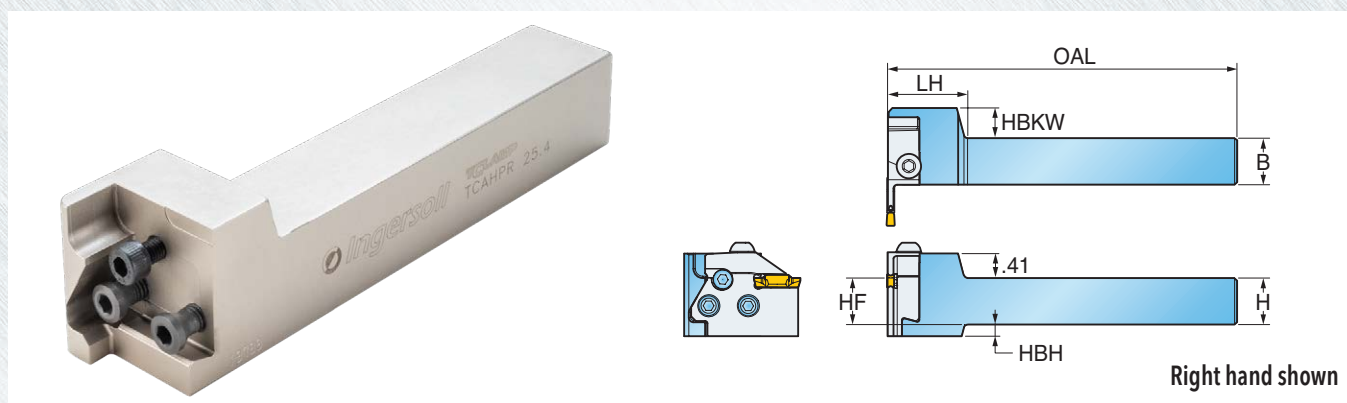

Right hand shown

Part Number	Dimension (inch)							Cartridge
	H Shank Height	HF Functional Height	B Shank Width	OAL Overall Length	HBH Head Bottom Offset Height	HBKW Head Back Offset Width	LH Head Length	
TCAHPR/L 19	.750	.750	.750	6.00	.23	.55	1.30	TCAEL/R TCAFR/L TCAQL/R
TCAHPR/L 25.4	1.000	1.000	1.000	6.00	-	.31	1.30	
TCAHPR/L 31.8	1.250	1.250	1.250	7.00	-	.05	1.30	

• Cartridge should be ordered separately

Spare Parts

Part Number	Screw	Security Screw	Wrench			
TCAHPR/L	TS 60190I	SH M5X0.8X16	L-W 4			



COOLBURST™ TCAHPR/L-TB PERPENDICULAR TYPE HOLDERS FOR CARTRIDGE W/ HIGH PRESSURE COOLANT

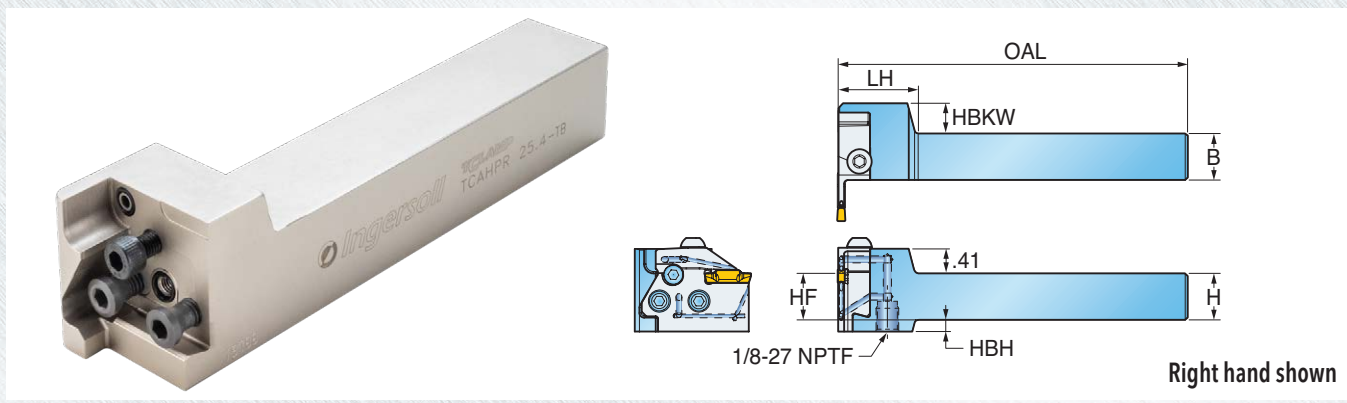

Part Number	Dimension (inch)							Cartridge
	H Shank Height	HF Functional Height	B Shank Width	OAL Overall Length	HBH Head Bottom Offset Height	HBKW Head Back Offset Width	LH Head Length	
TCAHPR/L 19-TB	.750	.750	.750	6.00	.23	.55	1.30	TCAEL/R-TB TCAQL/R-TB
TCAHPR/L 25.4-TB	1.000	1.000	1.000	6.00	-	.31	1.30	
TCAHPR/L 31.8-TB	1.250	1.250	1.250	7.00	-	.05	1.30	

• Cartridge should be ordered separately

Spare Parts

Part Number	Screw	Security Screw	Sealing Screw	O-Ring	Wrench	
TCAHPR/L-TB	TS 60190I	SH M5X0.8X16	SS M4X0.7X4-NL	O-RING ID5X1T	L-W 4	L-W 2



TCLAMP™ C-TCAHN PARALLEL TYPE C-ADAPTERS FOR CARTRIDGE

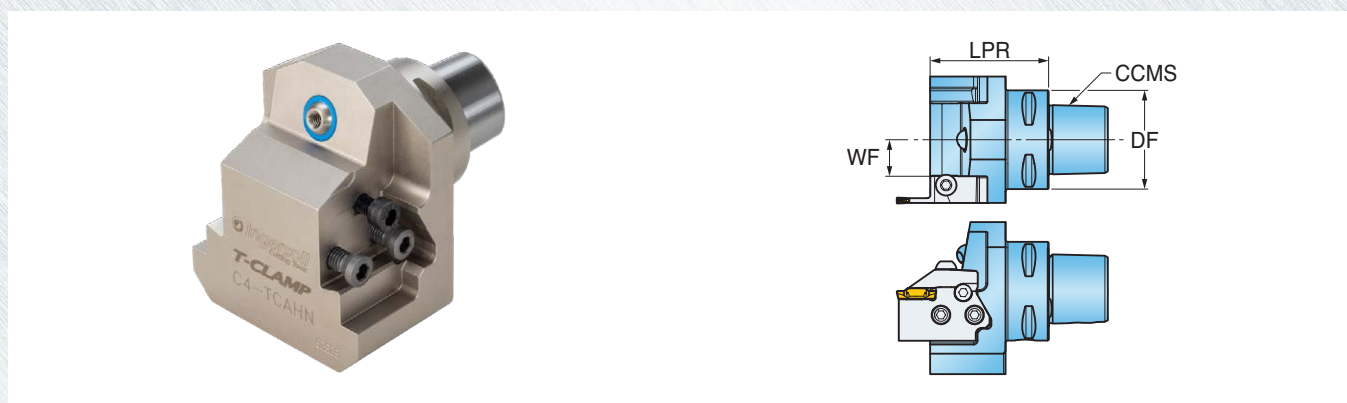

Part Number	Dimension (mm)				Cartridge
	CCMS Connection Code Machine Side	DF Flange Diameter	LPR Protruding Length	WF Functional Width	
C4-TCAHN	4	40	60	18.7	TCAER/L
C5-TCAHN	5	50	60	18.5	TCAFR/L
C6-TCAHN	6	63	60	19	TCAQR/L

• Cartridge should be ordered separately

Spare Parts

Part Number	Screw	Security Screw	Nozzle	Wrench		
C-TCAHN	TS 60190I	SH M5X0.8X16	NZ 125	L-W 4		



COOLBURST™ C-TCAHN-TB PARALLEL TYPE C-ADAPTERS FOR CARTRIDGE W/ HIGH PRESSURE COOLANT

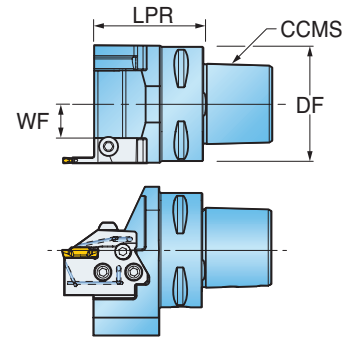

Part Number	Dimension (mm)				Cartridge
	CCMS Connection Code Machine Side	DF Flange Diameter	LPR Protruding Length	WF Functional Width	
C4-TCAHN-TB	4	40	55	11.5	TCAER/L-TB TCAQR/L-TB
C5-TCAHN-TB	5	50	58	13.7	
C6-TCAHN-TB	6	63	60	18.7	

• Cartridge should be ordered separately

Spare Parts

Part Number	Screw	Security Screw	Sealing Screw	O-Ring	Wrench	
C-TCAHN-TB	TS 60190I	SH M5X0.8X16	SS M4X0.7X4-NL	O-RING ID5X1T	L-W 4	L-W 2



TCLAMP™ C-TCAHPN PERPENDICULAR TYPE C-ADAPTERS FOR CARTRIDGE

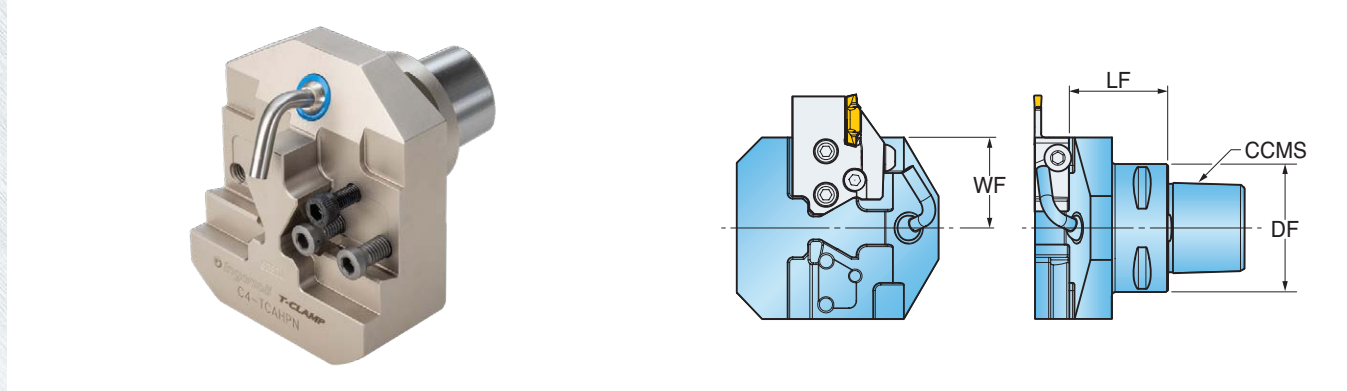

Part Number	Dimension (mm)				Cartridge
	CCMS Connection Code Machine Side	DF Flange Diameter	LF Functional Length	WF Functional Width	
C4-TCAHPN	4	40	40.5	34	TCAER/L
C5-TCAHPN	5	50	38.5	35.5	TCAFR/L
C6-TCAHPN	6	63	38.5	36	TCAQR/L

• Cartridge should be ordered separately

Spare Parts

Part Number	Screw	Security Screw	Nozzle	Pipe	Wrench
C-TCAHPN	TS 60190I	SH M5X0.8X16	NZ 125	NZP 5	L-W 4



COOLBURST™ C-TCAHPN-TB PERPENDICULAR TYPE C-ADAPTERS FOR CARTRIDGE W/ HIGH PRESSURE COOLANT

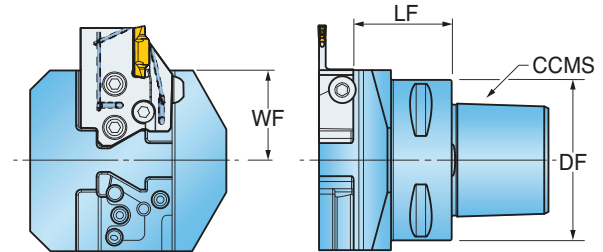

Part Number	Dimension (mm)				Cartridge
	CCMS Connection Code Machine Side	DF Flange Diameter	LF Functional Length	WF Functional Width	
C4-TCAHPN-TB	4	40	36.5	34	TCAER/L-TB TCAQR/L-TB
C5-TCAHPN-TB	5	50	36.5	35	
C6-TCAHPN-TB	6	63	38.5	35.5	

• Cartridge should be ordered separately

Spare Parts

Part Number	Screw	Security Screw	Sealing Screw	O-Ring	Wrench	
C-TCAHPN-TB	TS 60190I	SH M5X0.8X16	SS M4X0.7X4-NL	O-RING ID5X1T	L-W 4	L-W 2



TCLAMP™ TCAER/L CARTRIDGE FOR EXTERNAL TURNING AND GROOVING

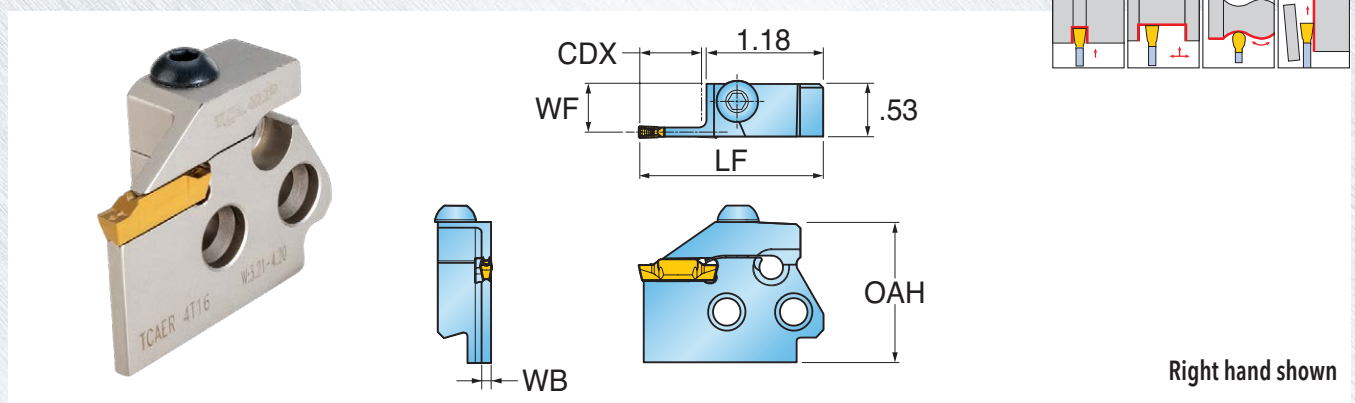

Right hand shown

Part Number	Insert Seat Size	Dimension (inch)					Holder	Insert
		LF Functional Length	WF Functional Width	WB Body Width	OAH Overall Height	CDX Cutting Depth Max.		
TCAER/L 1.4T12	1*	1.85	0.512	0.039	1.42	TCAHR/L TCAHPL/R C...-TCAHN C...-TCAHPN	TDC / J / T TDXU / XT / XY TSC / J TDUF / TDV	
TCAER/L 2T16	2	1.85	0.496	0.071	1.42			
TCAER/L 2T22	2	2.09	0.496	0.071	1.42			
TCAER/L 3T16	3	1.85	0.484	0.094	1.42			
TCAER/L 3T22	3	2.09	0.484	0.094	1.42			
TCAER/L 4T16	4	1.85	0.472	0.118	1.42			
TCAER/L 4T22	4	2.09	0.472	0.118	1.42			
TCAER/L 5T20	5	2.03	0.457	0.154	1.42			
TCAER/L 5T25	5	2.20	0.457	0.154	1.42			
TCAER/L 6T20	6	2.03	0.437	0.193	1.42			
TCAER/L 6T25	6	2.20	0.437	0.193	1.42			
TCAER/L 8T25	8	2.20	0.413	0.236	1.42			

*TDJ 1.4 insert only

Spare Parts

Part Number	Screw	Wrench			
TCAER/L	BH M6X1X16	L-W 4			



COOLBURST™ TCAER/L-TB CARTRIDGE FOR EXTERNAL GROOVING W/ HIGH PRESSURE COOLANT

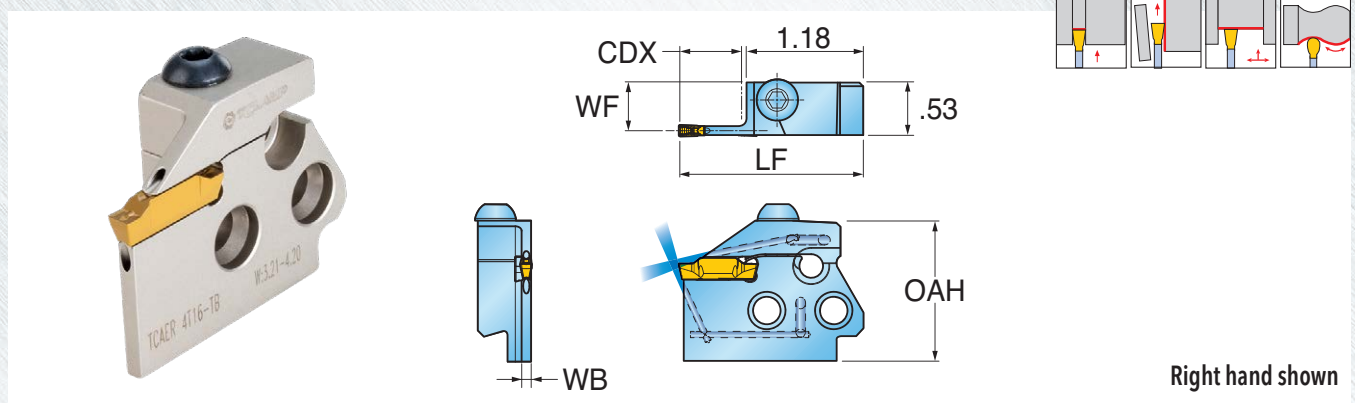

Part Number	Insert Seat Size	Dimension (inch)					Holder	Insert
		LF Functional Length	WF Functional Width	WB Body Width	OAH Overall Height	CDX Cutting Depth Max.		
TCAER/L 2T16-TB	2	1.85	0.496	0.071	1.42	0.630	TCAHR/L-TB	TDC / J / T
TCAER/L 3T16-TB	3	1.85	0.484	0.094	1.42	0.630	TCAHPL/R-TB	TDXU / XC / XY
TCAER/L 4T16-TB	4	1.85	0.472	0.118	1.42	0.630	C...TCAHN-TB	TSC / J
TCAER/L 5T20-TB	5	2.03	0.457	0.154	1.42	0.787	C...TCAHPN-TB	TDUF / TDV

Part Number	1015 PSI Flow Rate (GPM)	1450 PSI Flow Rate (GPM)	2030 PSI Flow Rate (GPM)
TCAER/L 2T16-TB	3.2 - 3.7	3.9 - 4.8	4.7 - 5.2
TCAER/L 3T16-TB	5.0 - 5.53	6.0 - 6.6	7.1 - 7.6
TCAER/L 4T16-TB	6.3 - 6.8	7.6 - 8.2	9.2 - 9.7
TCAER/L 5T20-TB	7.9 - 9.2	9.5 - 10.0	11.3 - 11.8

Spare Parts

Part Number	Screw	Wrench				
TCAER/L-TB	 BH M6X1X16	 L-W 4				



TCLAMP™ TCAFR/L CARTRIDGE FOR EXTERNAL FACE TURNING AND GROOVING

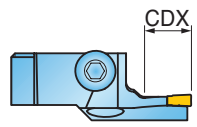

Fig. 1

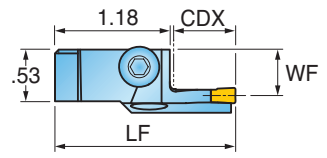
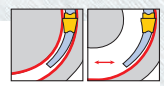
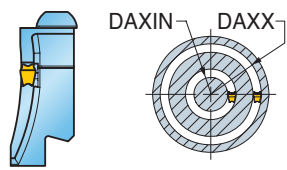
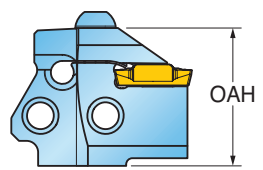

Fig. 2



Right hand shown

Part Number	Insert Seat Size	Dimension (inch)						Fig.	Holder	Insert
		LF Functional Length	WF Functional Width	CDX Cutting Depth Max.	OAH Overall Height	DAXIN Axial Groove I.D. Min.	DAXX Axial Groove O.D. Max.			
TCAFR/L 3T10-29-40RN	3	1.57	0.488	0.394	1.42	1.142	1.575	1	TCAHR/L TCAHPL/R C...TCAHN C...TCAHPN	TDC / J / T TDXU / XC / XY TSC / J TDUF / TDV
TCAFR/L 3T12-40-55RN	3	1.85	0.488	0.472	1.42	1.575	2.165			
TCAFR/L 3T12-55-75RN	3	1.85	0.488	0.472	1.42	2.165	2.953			
TCAFR/L 3T12-75-100RN	3	1.85	0.488	0.472	1.42	2.953	3.937			
TCAFR/L 3T12-100-140RN	3	1.85	0.488	0.472	1.42	3.937	5.512			
TCAFR/L 3T12-140-200RN	3	1.85	0.488	0.472	1.42	5.512	7.874			
TCAFR/L 4T16-34-50RN	4	1.85	0.472	0.630	1.42	1.339	1.969			
TCAFR/L 4T16-50-70RN	4	1.85	0.472	0.630	1.42	1.969	2.756			
TCAFR/L 4T16-70-100RN	4	1.85	0.472	0.630	1.42	2.756	3.937			
TCAFR/L 4T16-100-150RN	4	1.85	0.472	0.630	1.42	3.937	5.906			
TCAFR/L 4T16-150-250RN	4	1.85	0.472	0.630	1.42	5.906	9.843			
TCAFR/L 4T16-250RN	4	1.85	0.472	0.630	1.42	9.843	∞			
TCAFR/L 5T20-55-80RN	5	2.03	0.453	0.787	1.42	2.165	3.150	2		
TCAFR/L 5T20-80-120RN	5	2.03	0.453	0.787	1.42	3.150	4.724			
TCAFR/L 5T20-120-180RN	5	2.03	0.453	0.787	1.42	4.724	7.087			
TCAFR/L 5T20-180-300RN	5	2.03	0.453	0.787	1.42	7.087	11.811			
TCAFR/L 5T20-300RN	5	2.03	0.453	0.787	1.42	11.811	∞			
TCAFR/L 6T25-60-90-RN	6	2.20	0.433	0.984	1.42	2.362	3.543			
TCAFR/L 6T25-90-150RN	6	2.20	0.433	0.984	1.42	3.543	5.906			
TCAFR/L 6T25-150-250RN	6	2.20	0.433	0.984	1.42	5.906	9.843			
TCAFR/L 6T25-250-400RN	6	2.20	0.433	0.984	1.42	9.843	15.748			
TCAFR/L 6T25-400RN	6	2.20	0.433	0.984	1.42	15.748	∞			

∞ Infinity

Spare Parts

Part Number	Screw	Wrench			
TCAFR/L	BH M6X1X16	L-W 4			



GOLDFLEX™ TCAQR/L 20 CARTRIDGE FOR EXTERNAL GROOVING

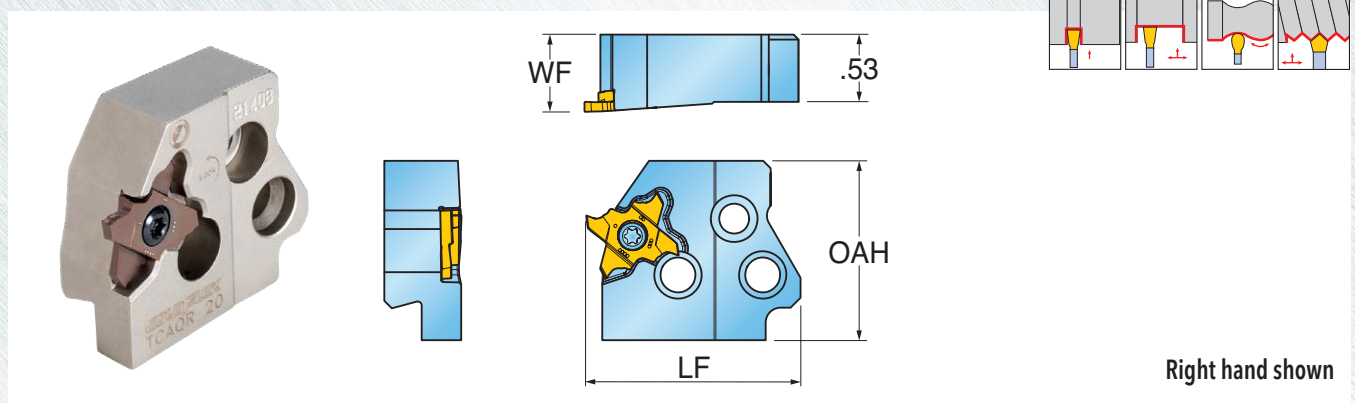

Right hand shown

Part Number	Dimension (inch)			Holder	Insert
	LF Functional Length	WF Functional Width	OAH Overall Height		
TCAQR/L 20	1.69	.610	1.42	TCAHR/L, TCAHPL/R, C...TCAHN, C...TCAHPN	TQ...20

Spare Parts

Part Number	Screw	Wrench			
	TCAQR 20	 TS 40A100L	 T-1508/5		
TCAQL 20	TS 40A100	T-1508/5			



COOLBURST™ TCAQR/L 20-TB CARTRIDGE FOR EXTERNAL GROOVING W/ HIGH PRESSURE COOLANT

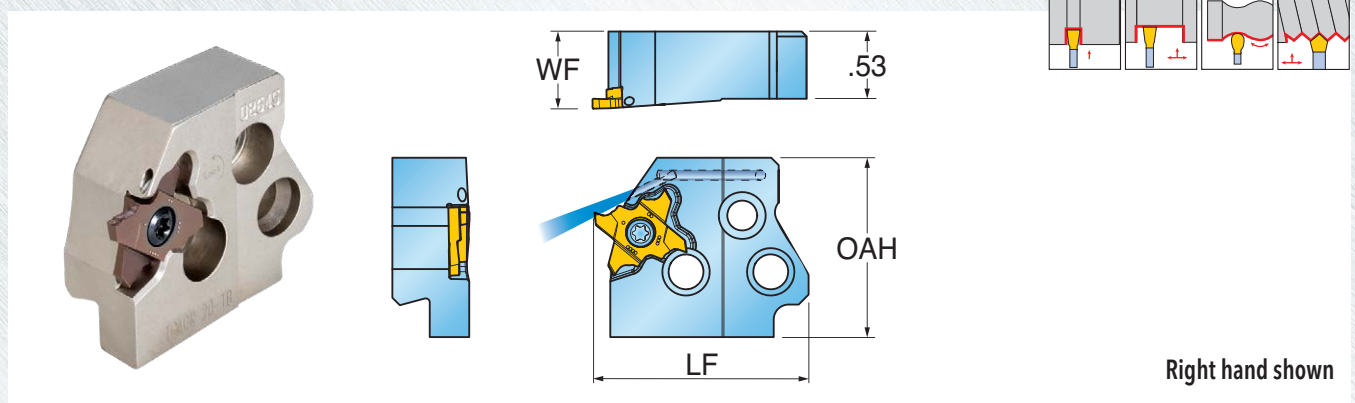



Right hand shown

Part Number	Dimension (inch)			Holder	Insert
	LF Functional Length	WF Functional Width	OAH Overall Height		
TCAQR/L 20-TB	1.69	.610	1.42	TCAHR/L, TCAHPL/R, C...TCAHN, C...TCAHPN	TQ...20

Part Number	1015 PSI Flow Rate (GPM)	1450 PSI Flow Rate (GPM)	2030 PSI Flow Rate (GPM)
TCAQR/L 20-TB	1.0 - 2.9	2.9 - 3.4	3.4 - 4.0

Spare Parts

Part Number	Screw	Wrench			
TCAQR 20-TB	 TS 40A100L	 T-1508/5			
TCAQL 20-TB	TS 40A100	T-1508/5			



GOLDFLEX™ TCAQR/L 27, 34 CARTRIDGE FOR EXTERNAL GROOVING

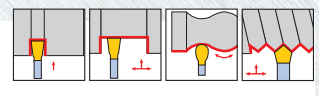
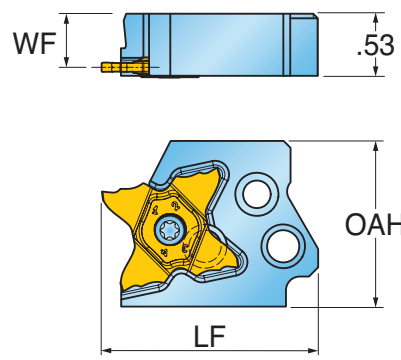

Right hand shown

Part Number	Dimension (inch)			Holder	Insert
	LF Functional Length	WF Functional Width	OAH Overall Height		
TCAQR/L 27	1.85	.484	1.42	TCAHR/L, TCAHPL/R C...TCAHN, C...TCAHPN	TQ...27
TCAQR/L 34	1.85	.460	1.42		TQ...34

Spare Parts

Part Number	Screw	Wrench				
TCAQR	TS 50125IL	T 10 / 20				
TCAQL	TS 50125I	T 10 / 20				



COOLBURST™ TCAQR/L 27-TB CARTRIDGE FOR EXTERNAL GROOVING W/ HIGH PRESSURE COOLANT

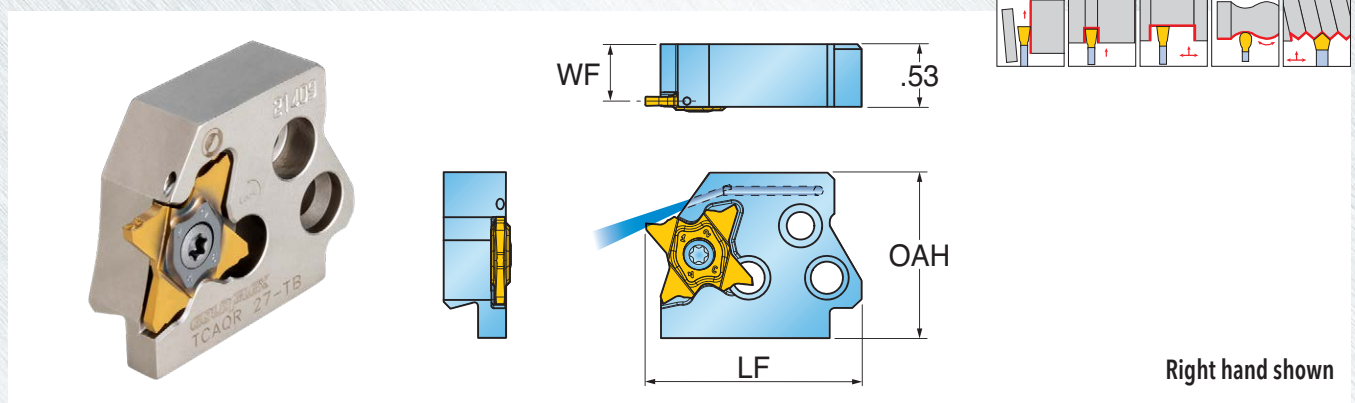

Right hand shown

Part Number	Dimension (inch)			Holder	Insert
	LF Functional Length	WF Functional Width	OAH Overall Height		
TCAQR/L 27-TB	1.85	.48	1.42	TCAHR/L-TB, TCAHPL/R-TB, C...TCAHN-TB, C...TCAHPN-TB	TQ...27

Part Number	1015 PSI Flow Rate (GPM)	1450 PSI Flow Rate (GPM)	2030 PSI Flow Rate (GPM)
TCAQR/L 27-TB	1.0 - 2.9	2.9 - 3.4	3.4 - 4.0

Spare Parts

Part Number	Screw 	Wrench 				
TCAQR 27-TB	TS 50125IL	T 10 / 20				
TCAQL 27-TB	TS 50125I	T 10 / 20				

TCLAMP™ CARTRIDGE AND HOLDER SELECTION

Parallel type

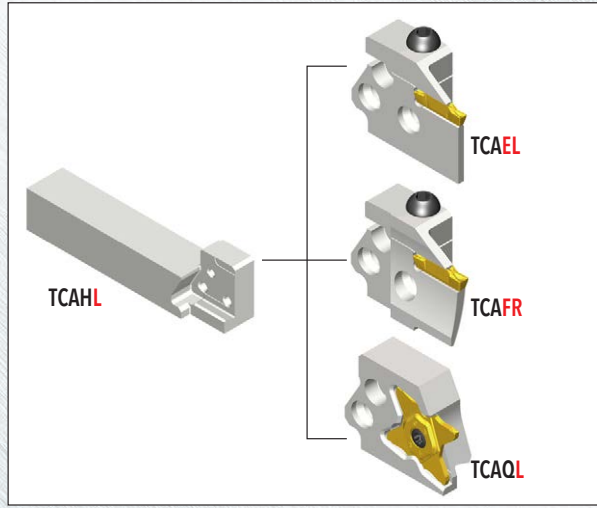
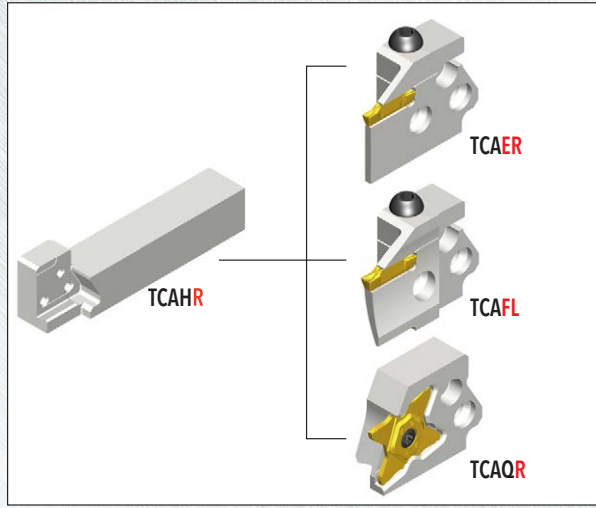

Perpendicular type

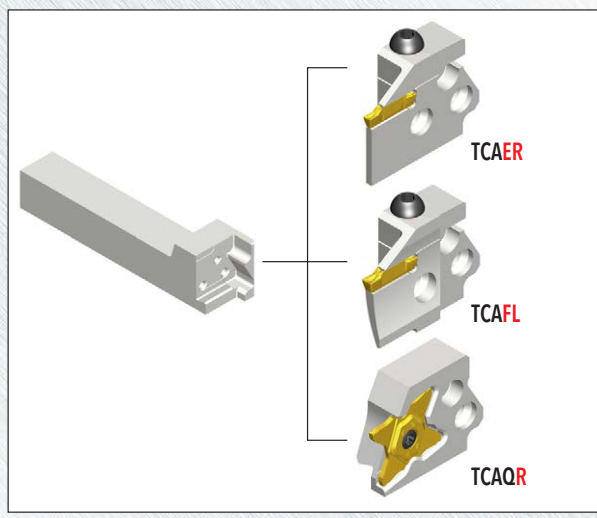
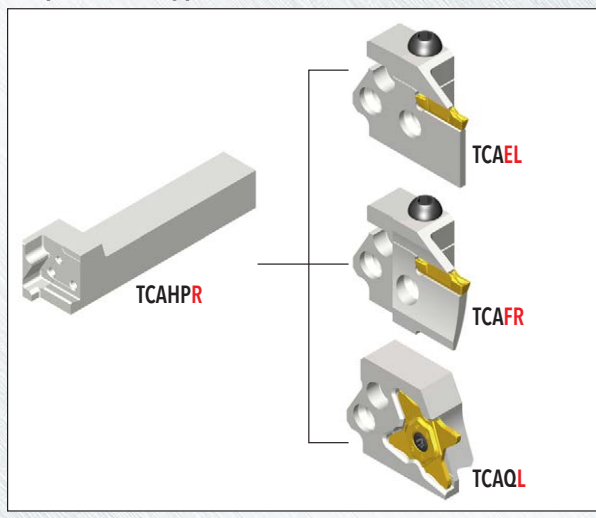

C-Adapter

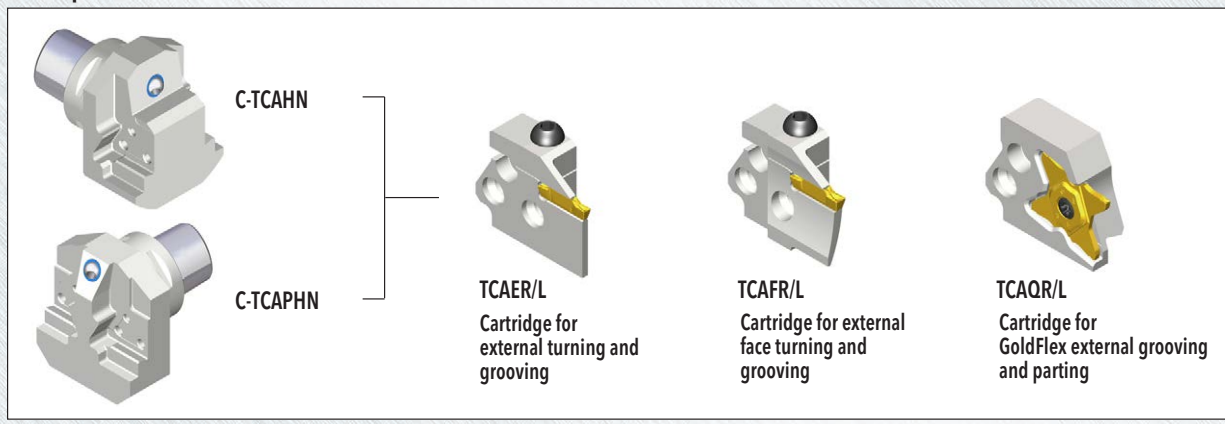



COOLBURST™ CARTRIDGE AND HOLDER SELECTION

Parallel type with high pressure coolant

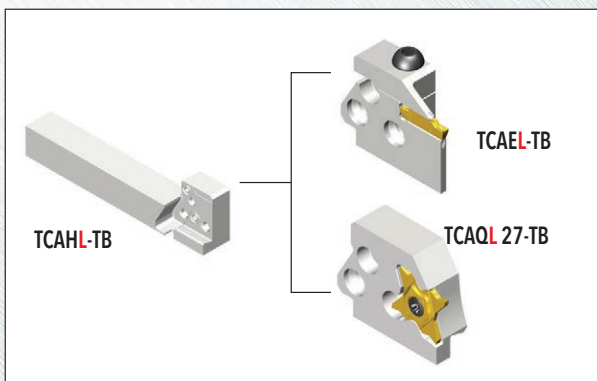
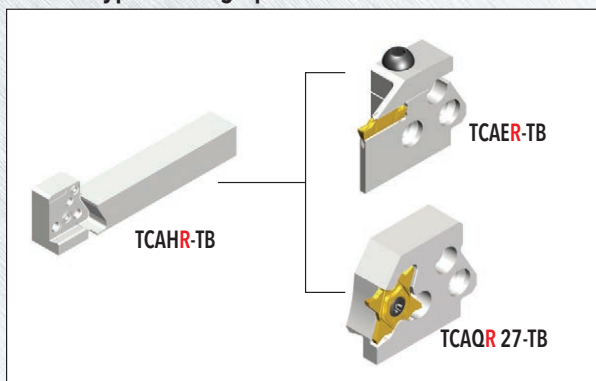

Perpendicular type with high pressure coolant

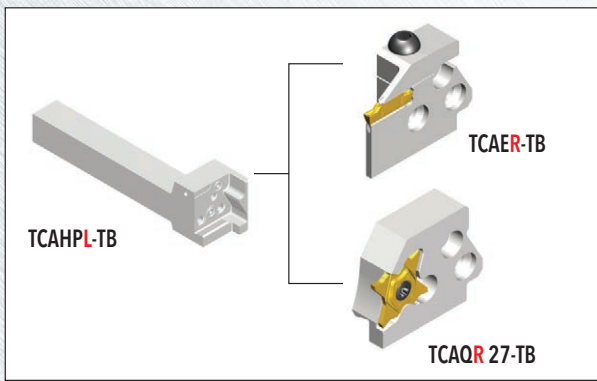
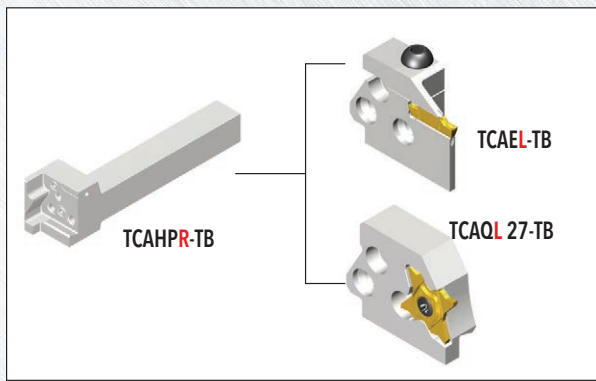

C-ADAPTER with high pressure coolant

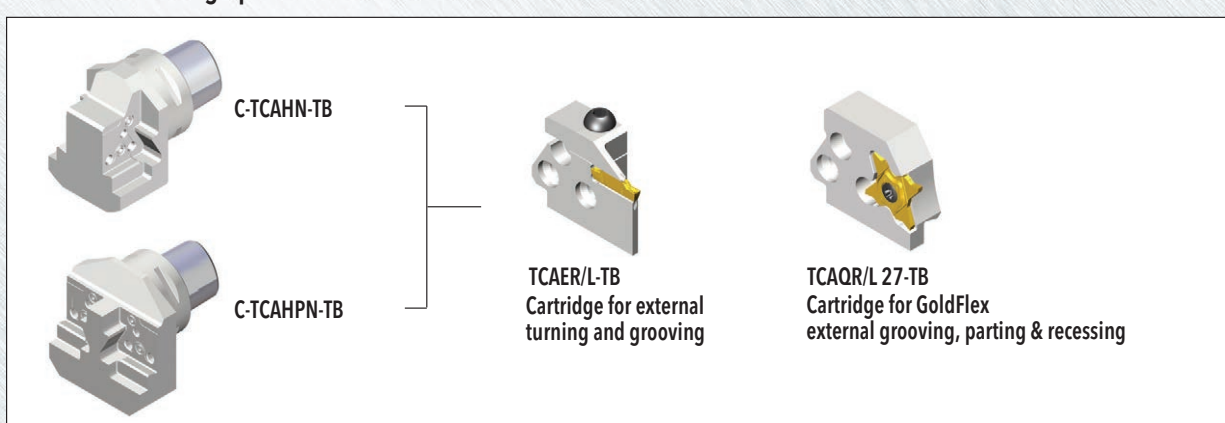

COMPLETE METALWORKING SOLUTIONS

(800) 991-4225
 www.ahbinc.com
 ISO Certified
 customerservice@ahbinc.com