



## JEL<sup>®</sup> VABOS EASY

Modular tool system – especially for machining aluminium

# JEL® VABOS EASY

Boring, counterboring and thread milling with the shortest possible delivery times.

JEL® VABOS, the variable boring and countersinking system, is a modular tool system which is particularly notable for its extremely high flexibility.

A broad based range of machining tasks can be carried out with just a few components – a central tool combined with inserts for universal shaping.

When manufacturing bores and threads on CNC machines significant time savings and improvements in quality can be achieved.

## Possible combinations

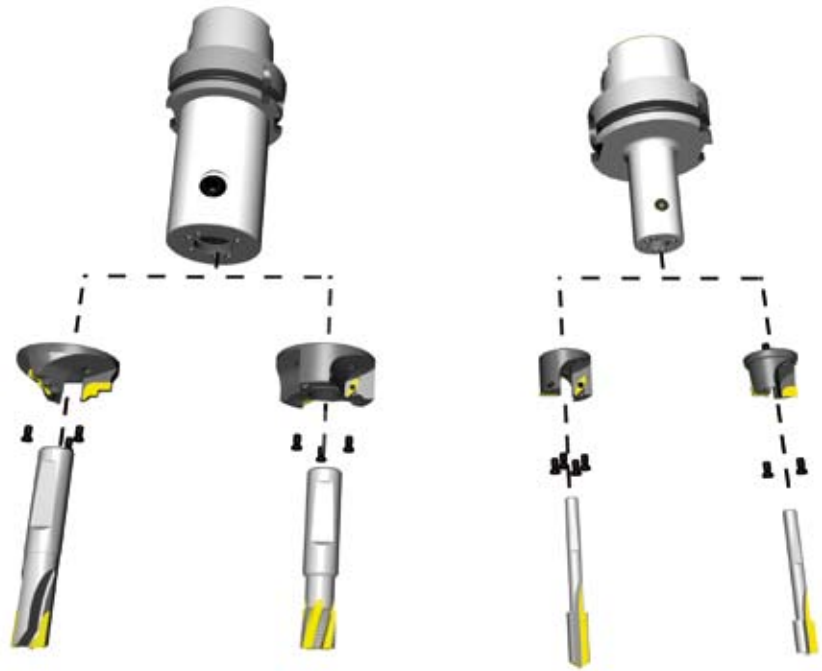

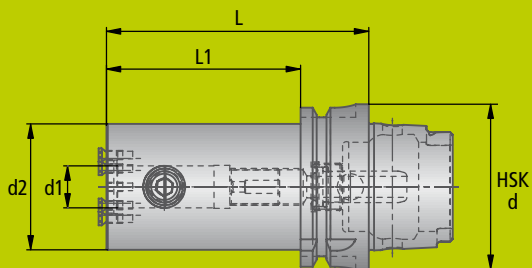

### JEL® VABOS EASY – Basic holder

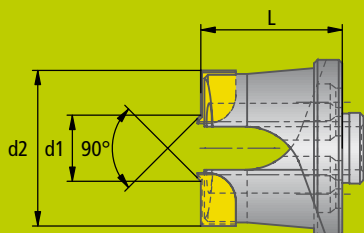

Basic holder							
HSK	d	d1	d2	short version		long version	
				Order No.	L	Order No.	L
63	6	25	5077502 6000600	80	5077602 6000600	160	
	8	28	5077502 6000800	80	5077602 6000800	160	
	10	35	5077502 6001000	80	5077602 6001000	160	
	12	42	5077502 6001200	90	5077602 6001200	160	
	14	44	5077502 6001400	90	5077602 6001400	160	
	16	48	5077502 6001600	100	5077602 6001600	160	

### JEL® VABOS EASY – Head



Head						
Type	d1	d2 max.	L max.	No. of flutes	No. of flutes	
				2	3	
				Order No.	Order No.	
with inserts 	6	25,6	20	507150 ..	507160 ..	
	8	28,6	25			
	10	35,6	25			
	12	42,6	25			
	14	44,6	30			
	16	48,6	30			
PCD brazed 	6	25,6	20	507350 ..	507360..	
	8	28,6	25			
	10	35,6	25			
	12	42,6	25			
	14	44,6	30			
	16	48,6	30			

Benefits for you:

- Large number of possible combinations
- One tool holder sufficient
- Lower tool costs
- Exchangeable head
- Easy exchangeability at re-tipping
- Easy assembly of the central tool
- HSK-A63 basic holder kept in stock as standard in two lengths
- Can be supplied as insert tools or in PCD brazed version
- Shortest possible delivery times

Application 1:

- Boring
- 90° countersinking
- Spotfacing

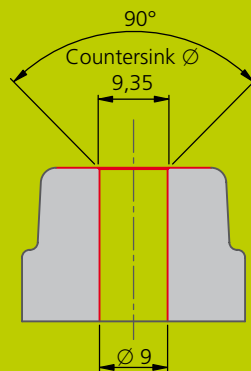

Application 2:

- Existing bore  
Shaped counterbore:
- Spotfacing and
  - 90° chamfering
  - External deburring
  - Thread milling M24x1,5

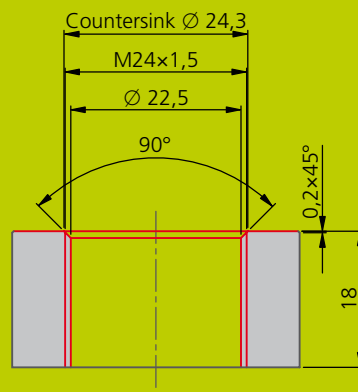

Application 3:

- Circular boring  $\varnothing 20$  mm
- Machining of complete counterbore

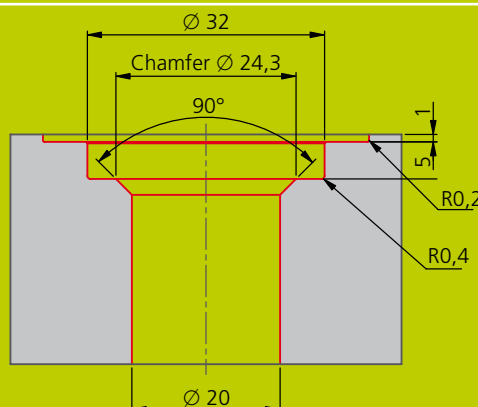

## Key to VABOS EASY calculations

Calculating the achievable spotface diameter in conjunction with boring and 90° countersinking using inserts.

Key:

d2 = Spotface diameter

D = Bore diameter

F = Chamfer width

P = Cutting length

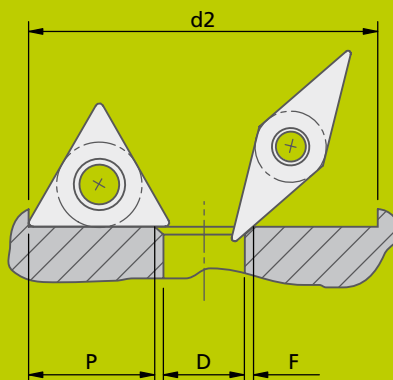

Spotface diameter  $d2 = \text{bore diameter } D + 2 \times \text{chamfer width } F + 2 \times \text{cutting length } P$  of inserts

Example: Bore diameter D: 5,0 mm  
Chamfer width F: 0,5 mm  
Cutting length P: 7,5 mm

$$d2 = 5,0 + 2 \times 0,5 + 2 \times 7,5$$

$$d2 = 21,0 \text{ mm}$$

Bore diameter D		
shank $\varnothing$	bore $\varnothing$	bore $\varnothing$
	D min	D max
6	4,0	6,0
8	6,0	8,0
10	8,0	10,0
12	10,0	12,0
14	12,0	14,0
16	14,0	16,0

Chamfer width F		
	F	F
	min	max
W89 03...002..	0,1	1,5

Cutting length P		
	P	P
	min	max
W30 04...02..	5,3	6,3
W30 04...03..	5,2	6,1
W30 04...04..	5,2	5,8
W30 14...02..	7,5	9,1
W30 14...04..	7,4	8,6

All inserts can be supplied both in carbide and in PC D



**GERMANY**

KOMET GROUP GmbH  
Zeppelinstraße 3  
74354 Besigheim  
Tel. +49(0)7143.373-0  
Fax +49(0)7143.373-233  
info@kometgroup.com

**GERMANY**

KOMET GROUP GmbH  
Werk Stuttgart-Vaihingen  
Ruppmannstraße 32  
70565 Stuttgart / Vaihingen  
Tel. +49(0)711.78891-0  
Fax +49(0)711.78891-11  
info@kometgroup.com

**BRAZIL**

Komet do Brasil Ltda.  
Rua Brasileira, 439  
07043-010 Guarulhos - São Paulo  
Tel. +55(0)11.6423-5502  
Fax +55(0)11.6422-0069  
info.br@kometgroup.com

**CHINA**

KOMET GROUP  
Precision Tools (Taicang) Co., Ltd.  
(Headquarter Asia Pacific)  
No. 5 Schaeffler Road  
Taicang, Jiangsu Province, 215400  
Tel. +86(0)512.535757-58  
Fax +86(0)512.535757-59  
info.cn@kometgroup.com

**FRANCE**

KOMET S.à.r.l.  
46-48 Chemin de la Bruyère  
B.P. 47  
69574 Dardilly CEDEX  
Tel. +33(0) 4 37 46 09 00  
Fax +33(0) 4 78 35 36 57  
info.fr@kometgroup.com

**GREAT BRITAIN**

KOMET (UK) Ltd.  
Unit 4 Triton Park  
Brownsover Road  
Swift Valley  
Rugby, CV21 1SG  
Tel. +44(0)1788.5797-89  
Fax +44(0)1788.5797-90  
info.uk@kometgroup.com

**INDIA**

KOMET Precision Tools India Pvt. Ltd.  
121/B, Bommasandra Industrial Area  
BANGALORE - 560 099  
Tel. +91-80-27834821  
Fax +91-80-27834495  
info.in@kometgroup.com

**ITALY**

KOMET Utensili S.R.L.  
Via Massimo Gorki n. 11  
20098 S. Giuliano Mil.  
Tel. +39-02-98 40 28 1  
Fax +39-02-98 44 96 2  
info.it@kometgroup.com

**JAPAN**

KOMET GROUP KK  
# 180-0006  
1-22-2 Naka-cho Musashino-shi  
Tokyo Japan  
Grand Preo Musashino 203  
Tel. +81(0)422 50 0682  
Fax +81(0)422 50 0683  
info.jp@kometgroup.com

**KOREA**

KOMET GROUP Precision Tools  
Korea Co.,Ltd.  
#201, Lotte IT Castle-2, 550-1,  
Gasandong, Geumcheon-gu,  
Seoul, 153-768  
Tel. +82(0)2.2082-6300  
Fax +82(0)2.2082-6309  
info.kr@kometkorea.com

**MEXICO**

KOMET de Mexico  
S. de R. L. de C.V  
Acceso „A“, No. 110  
Parque Industrial Jurica,  
76120, Queretaro, Qro. Mexico  
Tel. +52-442 2-18-25-44  
Fax +52-442 2-18-20-77  
info.mx@kometgroup.com

**AUSTRIA**

KOMET GROUP GmbH  
Wagramer Straße 173  
1220 Wien  
Tel. +43-1-2 59 22-04  
+43-1-2 59 22-12  
Fax +43-1-2 59 22 12-76  
info.at@kometgroup.com

**POLAND**

KOMET-URPOL Sp.z.o.o.  
ul. Stoczniewców 2  
47-200 Kędzierzyn-Koźle  
Tel. +48-77-482 90 60  
Fax +48-77-406 10 70  
info.pl@kometgroup.com

**RUSSIA**

KOMET GROUP GmbH  
ul. Spartakovskaya, 2V  
420107, Kazan  
Tel. +7 843 5704345  
Fax +7 843 2917543  
info.ru@kometgroup.com

**SWEDEN**

Square Tools AB  
Box 9177  
20039 Malmö  
Tel. +46-40-49 28 40  
Fax +46-40-49 19 95  
info.se@kometgroup.com

**SWITZERLAND**

KOMET DIHART AG Precision Tools  
Industriestrasse 2  
4657 Dulliken  
Tel. +41(0)62.2854-200  
Fax +41(0)62.2854-202  
info.ch@kometgroup.com

**SPAIN**

KOMET IBERICA TOOLS S.L.  
Planta baja, Local 6B  
Av. Corts Catalanes 9-11  
08173 Sant Cugat del Valles  
Tel. +34-93-583.96.20  
Fax +34-93-583.96.12

**CZECH REPUBLIC**

KOMET GROUP CZ s.r.o.  
Na Hůrce 1041/2,  
160 00 Praha 6  
Tel. +42(0)2 35 01 00 10  
Fax +42(0)2 35 31 18 90  
info.cz@kometgroup.com

**USA**

KOMET of America, Inc.  
2050 Mitchell Blvd.  
Schaumburg  
IL 60193-4544  
Tel. +1-8 47-9 23 / 84 00  
+1-8 47-9 23 / 84 80  
Fax +1-8 00-8 65 / 66 38  
customerservice@komet.com

[www.kometgroup.com](http://www.kometgroup.com)