



M042

Electronic
Compensating System

KomTronic®

KOMET
M04 20020
11000003



M042

M042 compensation tool:

Automatic tool change or permanent integration in spindle

KOMET®

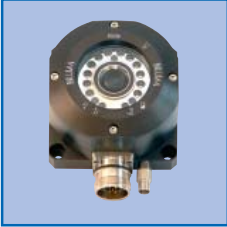

Infrared module
Data transmission

Infrared module IC55 (BLUM) can be used for M042 and plug gauge BG40 (BLUM) together.

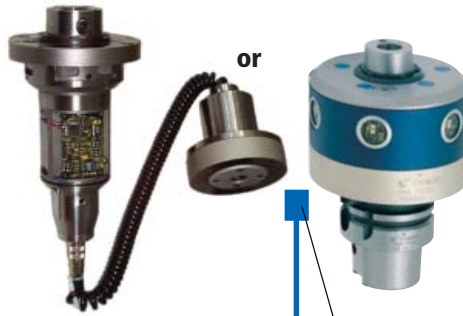

or



Stator
Power transmission

Control options:

Machine manufacturer

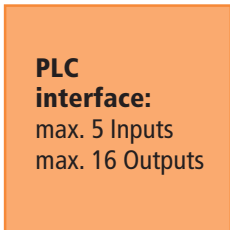

PLC interface:
max. 5 Inputs
max. 16 Outputs

Cable,
single core or
bus system

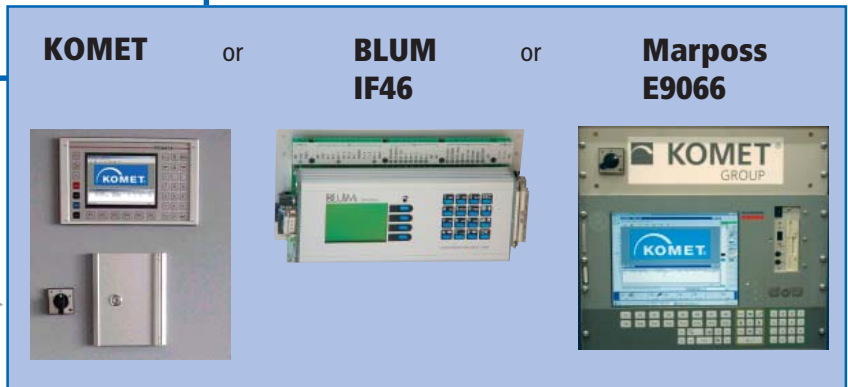

Measuring system manufacturer

Closed process loop
selectively via:



Gauging plug

or



Touch probe

or



Preprocess measuring

Flexibility with highest precision

Fully automatic control of cutting edge with the M042 Electronic Compensating System

Safeguarding the future - means coping with tomorrow's problems today. With this in mind, the KOMET M042 Electronic Compensating System offers maximum precision and efficiency.

The M042 is equipped with an absolute measuring system mounted directly on the slide, a servomotor and an infrared transceiver module. This enables the system to perform fully automatic micron adjustments on the diameter without manual intervention.

The M042 Electronic Boring System guarantees a maximum of quality, repeatability and reliability on machining centers, flex lines, special and transfer machines.

Aerospace



Automotive



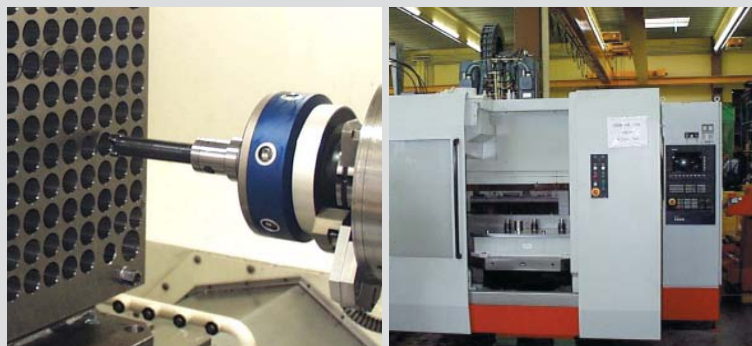

Machine Tool and Die/Mold





Technical specifications

- Infrared data transmission
- Inductive power supply
- Direct absolute measuring system on the slide
- Resolution 1 μm on diameter
- Positioning accuracy: standard deviation $\sigma < 1\mu\text{m}$
deviation $\Delta x + 1\mu\text{m}$
- Several heads possible on one machine (four digit tool address)
- Electronic control of adjusting range
- Maintenance free for up to 2 million adjusting cycles

Changeable systems

			
Dimensions	Diameter: 105 mm Length: 95 mm Weight: 2,4 kg (5.29 lbs) (without adapter)	Diameter: 160 mm Length: 140 mm Weight: 8,1 kg (17.86 lbs) (without adapter)	Cylinder boring on request \varnothing 63 mm onwards available
Spindle adapter	ISO / SK 40, HSK 63, ABS 63, (ISO / SK 50, HSK 80, HSK 100) others available on request	ISO / SK 50 HSK 100 others available on request	ISO / SK 50 HSK 63, HKS 80, HSK 100 others available on request
Tool connection	ABS 32	ABS 50 SBA 50	no tool connection, tool is specially designed for the requested diameter
Adjustment range in \varnothing / speed	-0,5 to +1,5 mm max. speed 4000 min^{-1} adjustment during rotation up to 2500 min^{-1} adjustment speed 50 $\mu\text{m/s}$	-0,5 to +1,5 mm max. speed 4000 min^{-1} adjustment during rotation up to 2500 min^{-1} adjustment speed 50 $\mu\text{m/s}$	-1,0 to +1,0 mm max. speed 4000 min^{-1} adjustment during rotation up to 4000 min^{-1} adjustment speed 250 $\mu\text{m/s}$
Remarks	<ul style="list-style-type: none"> • through tool coolant • manual pre-setting feature • compact tool changeable unit 	<ul style="list-style-type: none"> • through tool coolant • manual pre-setting feature • larger cutting diameters • heavier cuts • tool changeable 	<ul style="list-style-type: none"> • through tool coolant • tool changeable • forward finishing/chamfering, backwards fine boring with precision controlled cutting edge

Spindle mounting systems

			
Dimensions	Mounting diameter: 90 mm Length: 230 mm Weight: 4,6 kg (10.14 lbs) Overall length: 43 mm	Mounting diameter: 100 mm Length: 260 mm Weight: 6,9 kg (15.21 lbs) Overall length: 65 mm	Cylinder boring on request Ø 63 mm onwards available
Spindle adapter	Integral spindle mount	Integral spindle mount	Integral spindle mount
Tool connection	ABS 50	HSK 63	no tool connection, tool is specially designed for the requested diameter
Adjustment range in Ø / speed	-1,0 to +1,0 mm max. speed 7000 min ⁻¹ adjustment during rotation up to 7000 min ⁻¹ adjustment speed 250 µm/s	-0,7 to +1,3 mm max. speed 4000 min ⁻¹ adjustment during rotation up to 3500 min ⁻¹ adjustment speed 150 µm/s	-1,0 to +1,0 mm max. speed 4000 min ⁻¹ adjustment during rotation up to 4000 min ⁻¹ adjustment speed 250 µm/s
Remarks	<ul style="list-style-type: none"> power and data transmission at spindle end short overall length rigid construction highest precision and rigidity 	<ul style="list-style-type: none"> power and data transmission at spindle end short overall length rigid construction highest precision and rigidity 	<ul style="list-style-type: none"> power and data transmission at spindle end forward finishing/chamfering, backwards fine boring with precision controlled cutting edge

Power supply and data transmission

M042 Electronic Boring Heads

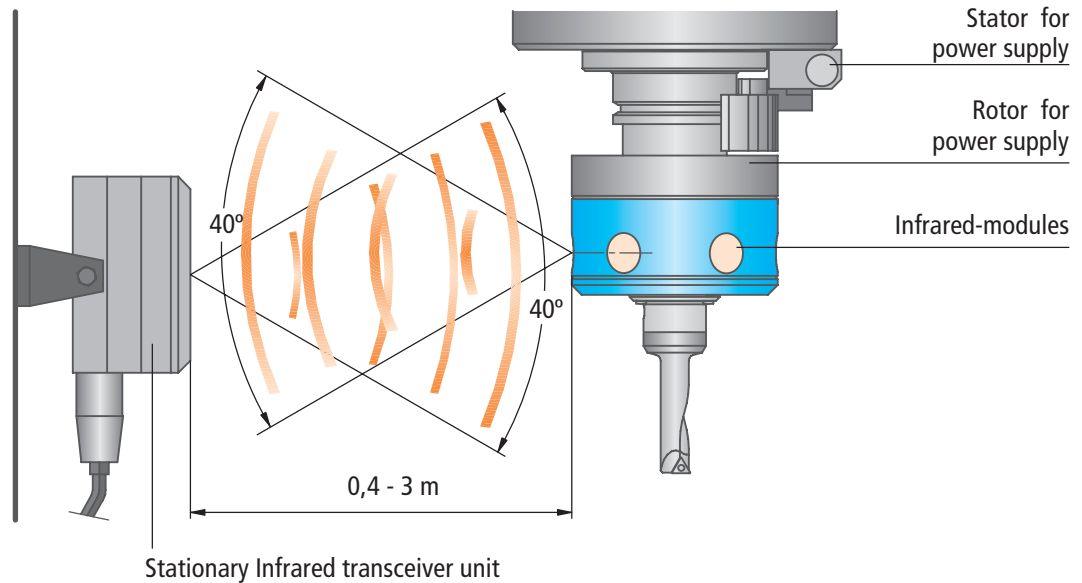

Inductive power supply

Energy is transmitted inductively with no contact surfaces. The stator element on the spindle housing is connected to the power supply via a cable. A distance of 1 mm between the stator and rotor is necessary for optimum and efficient inductive coupling. The rotor coil is located directly on the M042 Electronic Head and supplies stabilized DC voltage. The energy supply can be enabled with both a rotating or non-rotating head and is activated only when needed. The M042 does not require auxiliary energy for the data buffer.

Data transmission

The infrared beam guarantees the highest transmission speed and dependability of the M042. The infrared modules positioned on the circumference of the head ensure optimized data exchange. The infrared transceiver module fitted in the machining enclosure is connected to the M042 controller via a cable and transmits information to the M042 head.

Stator component for inductive power supply at the spindle



Infrared transceiver unit for installation in the machine enclosure



Energy and data transmission in the machine enclosure

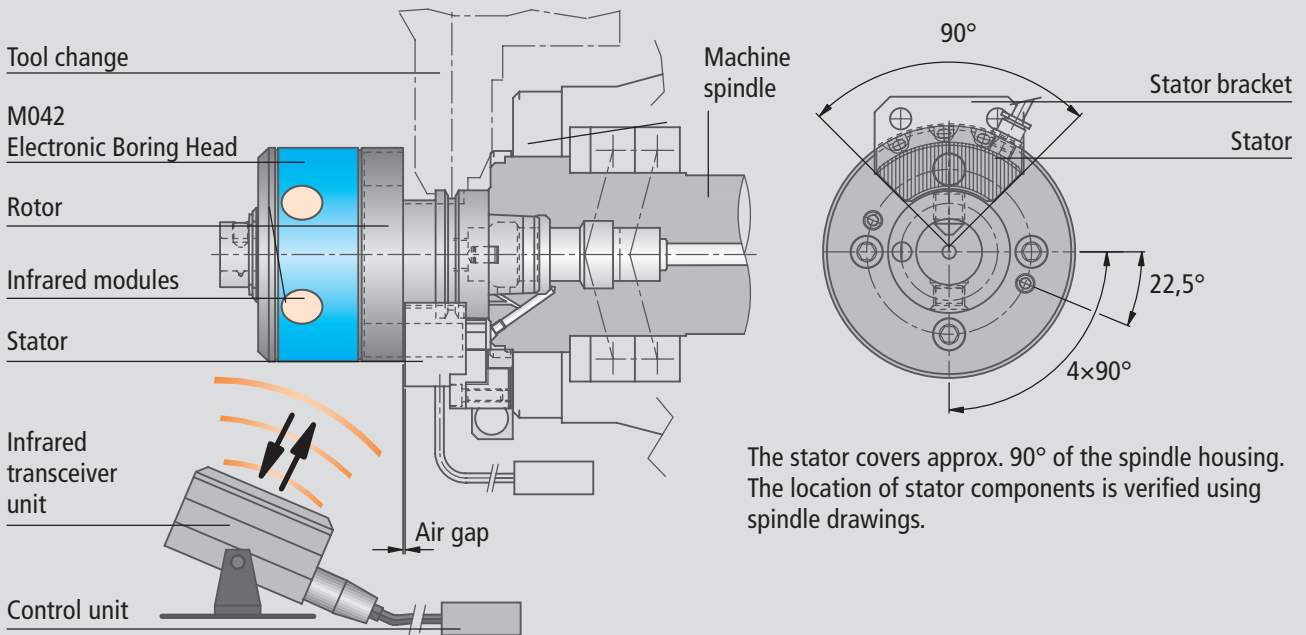

Product version: energy and data transmission at spindle end

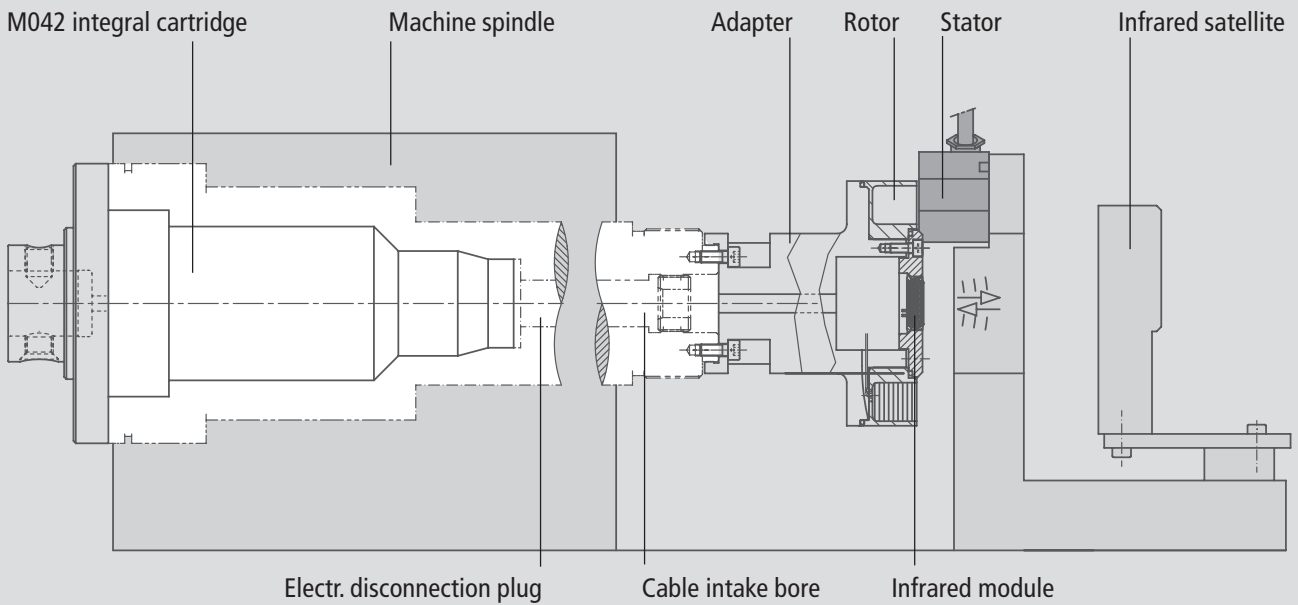

Rotor

Stator

Infrared satellite

M042
integral cartridge



Closed process loop: measuring and compensation

Control units

The complete software package

The operator friendly software of the M042 System is compatible to the Windows standard.

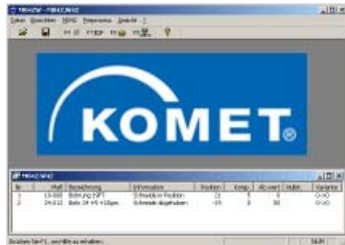

- Flexible configuration for numerous applications without software adaptation
- 16 M042 micro-adjustable heads per control unit
- 4 independently adjustable cutting edges per head
- 4 controllable KOMET pre-process measuring points
- Infrared gauging plug controllable
- Automatic operation without operator intervention
- Numerous functions for set-up and operation
- Settings with password security
- Error-control and warning messages
- Automatic function for retraction, positioning, compensation value, pre-process gauging
- Simultaneous functions for transfer machines (retraction, positioning)
- Standard Windows operation
- Warning messages for wear monitoring and maximum adjustment range
- Log file of system operations
- Standard open interface for communication with NC or PLC controller
- Customized communication interfaces available on request

BLUM IF46 compact system



Control for integrated BLUM measuring technology with BG40 gauging plug and basic functions for M042 compensation

E9066 control unit

Compensation with M042 and measuring using Marposs on one control unit. All power supply components are integrated in the control unit, including interfaces for accessories utilised for communication between the machine, M042 micro-adjustable head and measuring medium.

Control unit with integrated power supply and communication ports



Technical data:

Computer:
Pentium 200 processor
2 x RS 232 interfaces
1 x parallel

Keyboard:
External control keyboard
(PS/2) numerical pad option
+ 12 function keys

Monitor:
12,1" TFT colour screen
shockproof

Housing:
10 HE, IP 54 protection class
Heat exchanger
Blue RAL 5010

The technical notes provided in the **application details** depend on the environmental and application conditions (such as machine, environmental temperature, lubrication/coolant used and desired machining results): these are based on proper application conditions, use and compliance with the spindle speed limits given for the tools.

Closed process loop: measuring and compensation

Several gauging systems may be utilized

Flexibility, thanks to post-process measuring

The flexible design of the control unit I/O ports have a flexible design enables the use of different standard gauging devices.



Changeable touch probe

Changeable touch probes measure the bore by using the machine axes. Evaluation and computation of the measuring results are realized in the NC control.

The correction value is transmitted via an electrical interface to the M042 control unit.



Changeable plug gauge

Changeable plug gauges (e.g. from BLUM) can be used in machining centers.



If a touch probe or plug gauge from BLUM is used, the data transmission can only be carried out by infrared module IC55.

Minimizing set-up-time with the KOMET pre-process gauging unit

Pre-process gauging involves measurement of the exact rotating diameter of the insert and its correction before machining. An exact diameter can be set with μ accuracy, regardless of the accuracy of the spindle adaptation (tool change repeatability).

The innovative pre-process gauging unit provides a system which compensates for several influences on bored hole diameter quality (e.g. insert wear or tool change repeatability). Set-up and calibration of the unit is realized with the aid of the M042 control unit.

The waterproof (in compliance with IP65 protection class) gauging device is mounted in the machining enclosure.

Requirement for the KOMET pre-process gauging unit

- Installed M042 system
- Contactless positioning of the M042 cutting insert by spindle orientation or using the pneumatic probe retraction option.
- Slow spindle rotation opposite to the insert cutting direction

Speed and measuring time

- At least two spindle revolutions opposite to the insert cutting direction are required.
- Typical speeds for a maximum error of $\pm 1 \mu\text{m}$:

Diameter D	Speed n	Time t
20 mm	60 rpm	2 sec
50 mm	40 rpm	3 sec
100 mm	30 rpm	4 sec

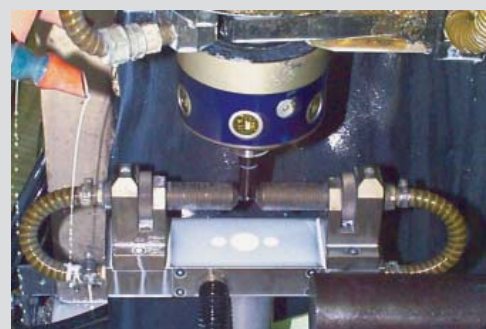

Closed process loop: measuring and compensation

Integration options

In machining centers, special and transfer machines

Status, warning and error message data exchange

Data exchange between the machine control and the M042 control processor is realized via M or H functions. This is communicated via parallel or serial interfaces to the M042 system. M042 system status, warning and error messages are transmitted to the machine control. This enables interruption of the automatic sequence and helps avoid machining errors.

1

KOMET pre-process gauging unit and M042 system - machining center

A parallel port provides the interface between the NC control and the M042 control unit. The M042 control unit determines the gauging and correction value from data supplied by the pre-process gauging unit.

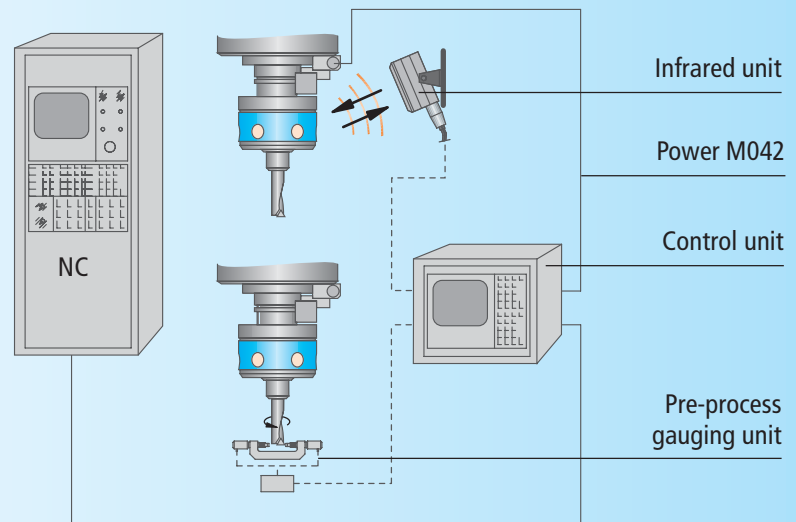

Programming example for NC-control

```
N 10 M 19 S0      (Orientation)
N 20 G 56         (Work-offset.)
N 30 G0 X0 Y0    (Position X-Y to gauging point)
N 40 Z 15
N 50 G1 Z0 F 2000 (Position Z)
N 60 G0 S40 M4   (Rotate spindle)
N 70 H63         (Trigger measuring)
N 80 M 5         (Spindle stop)
N 90 G0 Z 100    (Retract)
N 100 M 17       (End sub-program)
```

2

Touch probe and M042 System - machining center

The NC control determines the correction value with the aid of the touch probe and transmits the data to the M042-control unit.

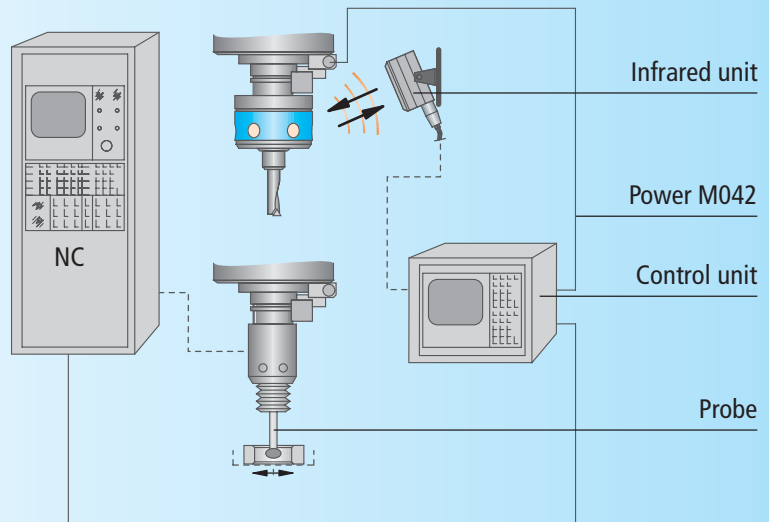

3

Post-process gauging unit and M042 System - special/transfer machine

The post-process gauging system determines the correction value for each head and transmits the data to the M042 control unit.

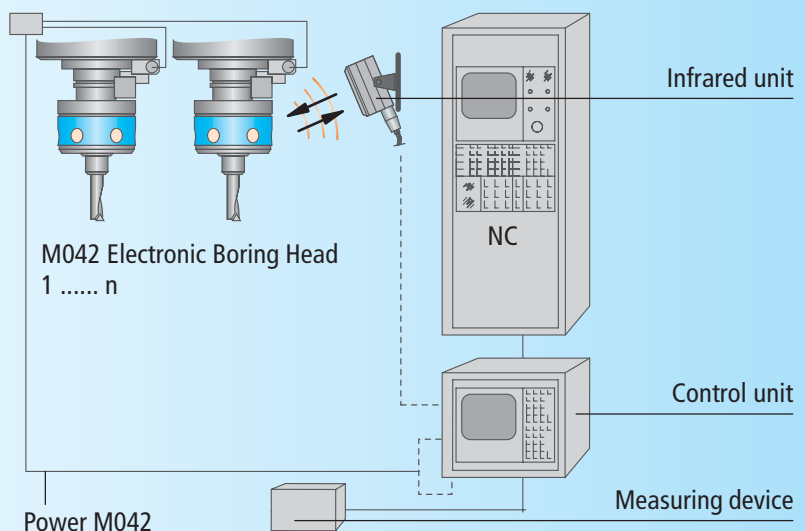

Komtronic®

KOMET GROUP GmbH
Zeppelinstraße 3
D-74354 Besigheim
Tel. +49(0)7143.373-0
Fax +49(0)7143.373-233
info@kometgroup.com
www.kometgroup.com

Germany

KOMET Precision Tools GmbH & Co. KG
Zeppelinstraße 3
D-74354 Besigheim
Tel. +49(0)7143.373-0
Fax +49(0)7143.373-233
info@kometgroup.com

Germany

JEL Precision Tools GmbH + Co. KG
Ruppmannstraße 32
D-70565 Stuttgart / Vaihingen
Tel. +49(0)711.78891-0
Fax +49(0)711.78891-11
info@kometgroup.com

Brazil

KOMET do Brasil, Ltda.
Rua Alexandre de Gusmao, 399
São Paulo - SP, BRASIL
Tel. ++55-11-56 82-00 01
Fax ++55-11-56 81-98 02
komet@kometdobrasil.com.br

China

KOMET GROUP
Precision Tools (Taicang) Co., Ltd.
(Headquarter Asia Pacific)
No. 5 Schaeffler Road
Taicang, Jiangsu Province, 215400
China
Tel. +86(0)512.535757-58
Fax +86(0)512.535757-59
info@kometgroup.cn

France

KOMET France S.A.R.L.
46-48 Chemin de la Bruyère
B.P. 47
F-69572 Dardilly CEDEX
Tel. +33 04 37 46 09 00
Fax +33 04 78 35 36 57
komet@komet-france.com

Great Britain

KOMET (UK) Ltd.
Unit 4 Triton Park
Brownsover Road
Swift Valley / Rugby
CV21 1SG
Tel. +44(0)1788.5797-89
Fax +44(0)1788.5797-90
info@kometgroup.co.uk

India

KOMET Precision Tools India Pvt. Ltd.
121/B, Bommasandra Industrial Area
BANGALORE - 560 099 INDIA
Tel. ++91-80-7 83 48 21
Fax ++91-80-7 83 44 95
info@kometindia.com

Italy

KOMET Utensili S.R.L.
Via Menotti Serrati 74
I-20098 S. Giuliano Mil.
Tel. ++39-02-98 40 28 1
Fax ++39-02-98 44 96 2
kometita@tin.it

Japan

KOMET GROUP KK
Tomei Grand BLD
2-30 Issha Meito
465-0093 Nagoya
Japan
Tel. +81(52)7092311
Fax +81(52)7027022
info@kometgroup.jp

Mexico

KOMET de Mexico
S. de R. L. de C.V
Acceso „A“, No. 110
Parque Industrial Jurica,
76120, Queretaro, Qro. Mexico
Tel. ++52 442 2-18-25-44
Fax ++52 442 2-18-20-77
KometdeMexico@komet.com

Austria

KOMET Werkzeuge Ges.m.b.H.
Wagramer Straße 173
A-1220 Wien
Tel. ++43-1-2 59 22-04
++43-1-2 59 22-12
Fax ++43-1-2 59 22 12-76
info@komet.at

Poland

KOMET-URPOL Sp.z.o.o.
ul. Stoczniewców 2
PL 47-200 Kędzierzyn-Koźle
Tel. ++48-77-482 90 60
Fax ++48-77-406 10 70
urpol@urpol.com.pl

Sweden

Square Tools AB
Box 9177
S-20039 Malmö
Tel. ++46-40-49 28 40
Fax ++46-40-49 19 95
square@squaretools.se

Switzerland

Dihart AG Precision Tools
Industriestrasse 2
CH-4657 Dulliken
Tel. ++41-62-2 85 42 00
Fax ++41-62-2 85 42 99
info@dihart.ch

USA

KOMET of America, Inc.
2050 Mitchell Blvd.
Schaumburg
IL 60193-4544 USA
Tel. ++1-8 47-9 23 / 84 00
++1-8 47-9 23 / 84 80
Fax ++1-8 00-8 65 / 66 38
customerservice@komet.com