



**COMPLETE
METALWORKING
SOLUTIONS**

(800) 991-4225

www.ahbinc.com

ISO Certified

customerservice@ahbinc.com

SIGC

High-Precision Small Internal Grooving

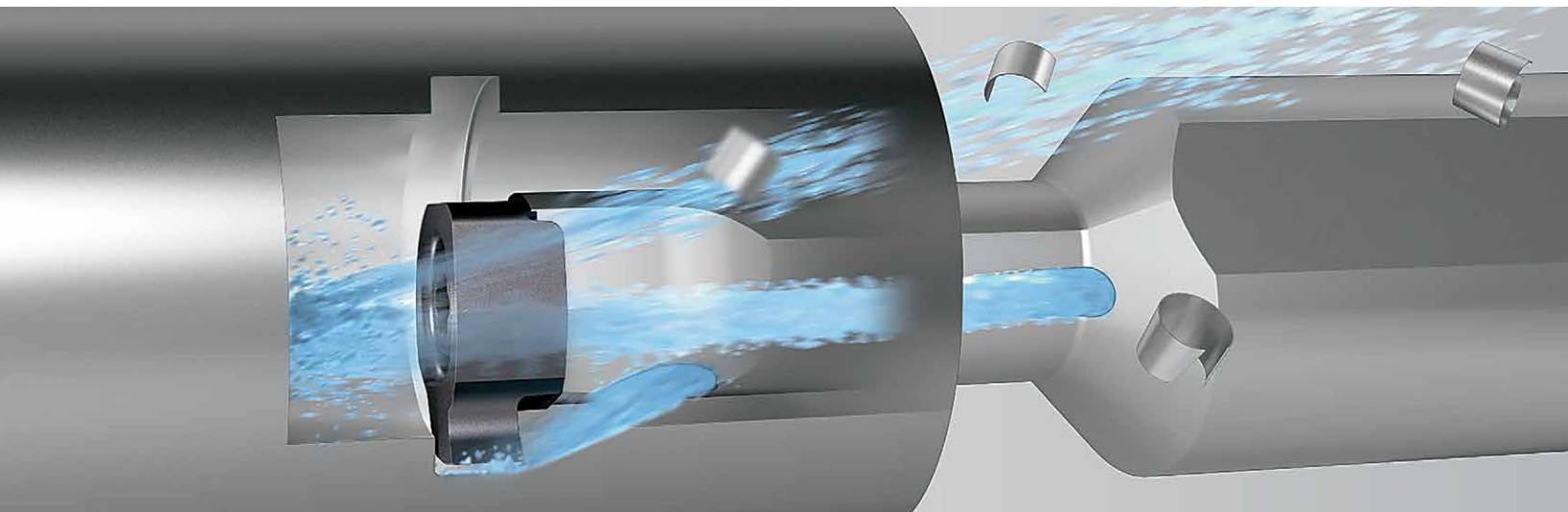

High-Precision Small Internal Grooving with a $\varnothing 8$ mm Minimum Bore Diameter

Newly Developed Clamping System Ensures a Firm Insert Hold for High-Precision Machining

Excellent Chip Evacuation with Double Coolant Holes

Long Tool Life with MEGACOAT NANO PLUS "PR1725"

Minimum Bore Diameter $\varnothing 8$ mm



**"Excellent" Steel Bars and
Carbide Shank Bars Available**



SIGC

Series for Small Internal Grooving

New Clamping System Ensures a Firm Insert Hold for High-Precision Machining

Excellent Chip Evacuation with Double Coolant Holes

Optimized Flute Shape with a $\varnothing 8\text{mm}$ Minimum Bore Diameter

1 Firm Insert Clamping System for High-Precision Machining

High strength clamping action by pulling the bottom surface of the insert in axial direction
Stable machining is achieved by ensuring a firm clamp on the insert

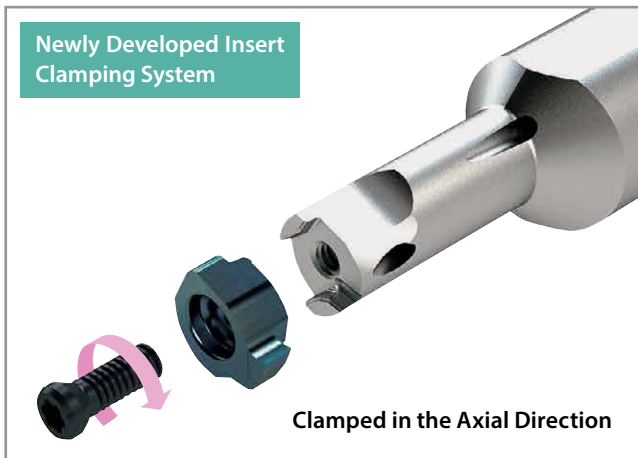

Clamping Part

Large contact surface improves chip stability

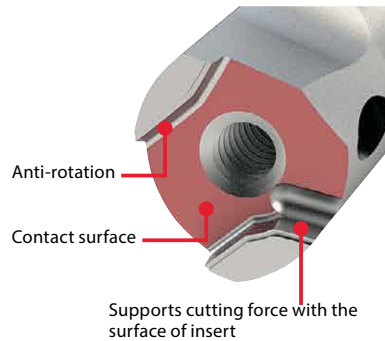

SIGC

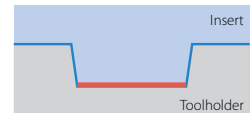

Bottom Surface Contact

Competitor A

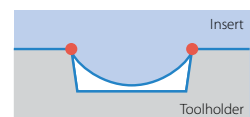

Point Contact

Cutting Edge Stability Position Comparison (Internal evaluation)

Cutting Edge Movement Amount in Z Direction (in.)

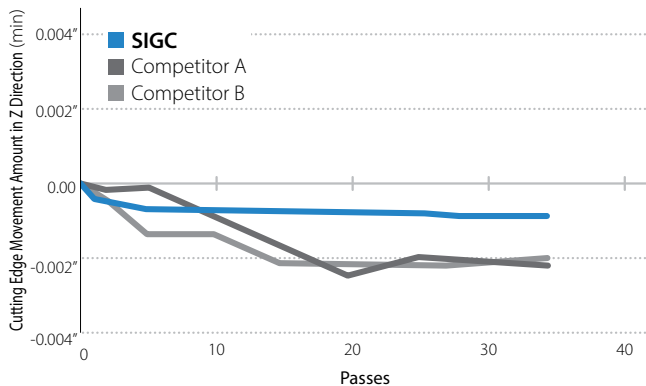
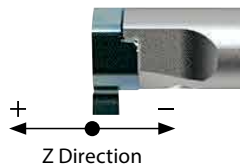

Cutting Conditions : $V_c = 160 \text{ sfm}$, $D.O.C. = 0.008''$, $f = 0.002 \text{ ipr}$, Wet Workpiece: 4137 External Turning

Front of Cutting Edge Angle Variation ($^\circ$)

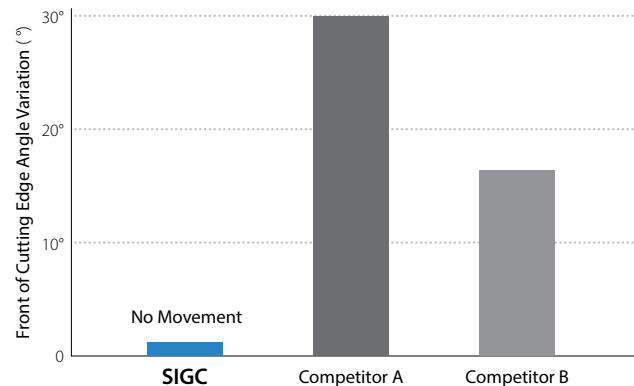
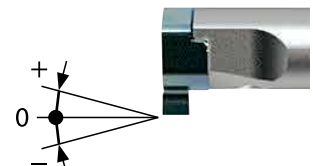

SIGC ensures high precision machining by preventing cutting edge position movement

2 Excellent Chip Evacuation

Excellent Chip Evacuation with Double Coolant Holes and Optimized Flute Shape

Double Coolant Holes

Promotes chip evacuation by aiming at bore face of workpiece

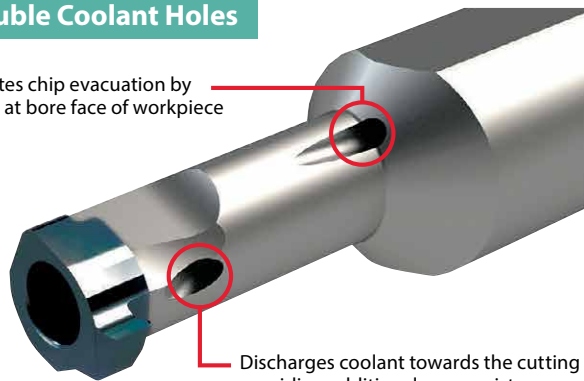

Discharges coolant towards the cutting edge providing additional wear resistance

Flute Shape

Smoothly evacuates chips towards the back of the toolholder

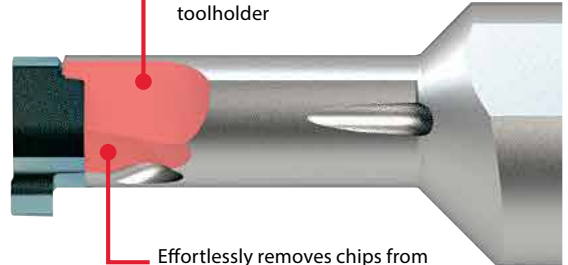

Effortlessly removes chips from the cutting edge

Provides better solutions for chip evacuation in small internal grooving applications
Prevents chip crunching

Chip Evacuation Comparison (Internal evaluation)

Cutting Conditions : Vc = 164 sfm, D.O.C. = 0.039" (Shouldering), f = 0.001 ipr, Wet (Internal Coolant), Workpiece : SCM415 (JIS), With Edge Width 0.079"

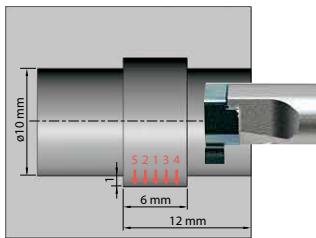

Residual Chips Rate (%)

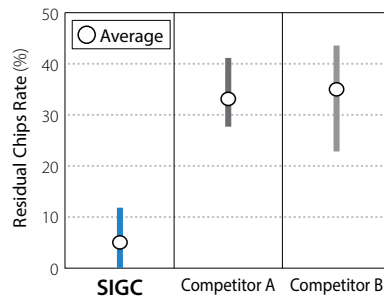

$$\text{Residual Chips Rate (\%)} = \frac{\text{Weight of remaining chip in the hole (g)}}{\text{Weight of chips removed (g)}} \times 100$$



No Remaining Chips
Good Chip Evacuation

3 Broad Tooling Lineup for Various Internal Grooving Applications

"Excellent" Bars and Carbide Shank Bars Available

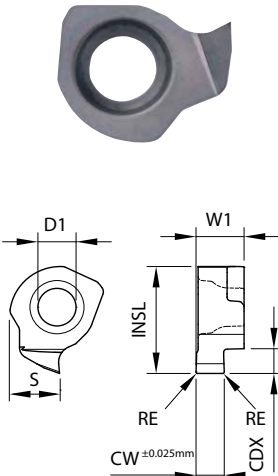

Applicable Inserts

Insert Right-hand Insert Shown	Part Number	Dimensions (mm)							MEGACOAT NANO PLUS		MEGACOAT NANO		Applicable Toolholders	
		CW	CDX	RE	W1	INSL	S	D1	PR1725		PR1535			
									R	L	R	L		
	GC08 ^{R/L}	100-005	1.00	1.5	0.05	3.4	7.7	3.5	2.7	●	●	●	●	SIGC ^{R/L} 0812-EH SIGC ^{R/L} 0806-WH
		120-005	1.20							●	●	●	●	
		125-005	1.25							●	●	●	●	
		150-010	1.50	●	●	●	●							
		200-010	2.00	●	●	●	●							
	GC10 ^{R/L}	100-005	1.00	2.2	0.05	4.7	9.6	4.4	3.5	●	●	●	●	SIGC ^{R/L} 1016-EH SIGC ^{R/L} 1008-WH-L85 SIGCR1008-WH-L100
		120-005	1.20							●	●	●	●	
		125-005	1.25							●	●	●	●	
		145-010	1.45	●	●	●	●							
		150-010	1.50	●	●	●	●							
		200-010	2.00	●	●	●	●							
		250-020	2.50	●	●	●	●							
	GC12 ^{R/L}	100-005	1.00	2.2	0.05	4.7	11.6	5.4	3.5	●	●	●	●	SIGC ^{R/L} 1216-EH SIGCR1210-WH-L95 SIGC ^{R/L} 1210-WH-L110
		120-005	1.20							●	●	●	●	
		125-005	1.25							●	●	●	●	
145-010		1.45	●	●	●	●								
150-010		1.50	●	●	●	●								
200-010	2.00	●	●	●	●									
250-020	2.50	●	●	●	●									
300-020	3.00	●	●	●	●									

· CDX : shows available grooving depth
 · Inserts are sold in 5 piece boxes

● : Standard Item

Recommended Cutting Conditions

Workpiece	Recommended Insert Grade (Cutting Conditions Vc : sfm)		(1) Feed Rate for Grooving (ipr)			Notes
	MEGACOAT NANO PLUS	MEGACOAT NANO	(2) Feed Rate for Traversing (ipr)			
			(3) D.O.C. for Traversing (in)			
			PR1725	PR1535	GC08 ^{R/L} ...	
Carbon Steel	★ 160 ~ 260	☆ 160 ~ 260	(1) 0.0004 ~ 0.0012	(1) 0.0008 ~ 0.0016	(1) 0.0008 ~ 0.0016	Wet
			(2) 0.0004 ~ 0.0012	(2) 0.0008 ~ 0.0016	(2) 0.0008 ~ 0.0016	
			(3) Max. 0.0020	(3) Max. 0.0020	(3) Max. 0.0039	
Alloy Steel	★ 160 ~ 260	☆ 160 ~ 260	(1) 0.0004 ~ 0.0012	(1) 0.0008 ~ 0.0016	(1) 0.0008 ~ 0.0016	
			(2) 0.0004 ~ 0.0012	(2) 0.0008 ~ 0.0016	(2) 0.0008 ~ 0.0016	
			(3) Max. 0.0020	(3) Max. 0.0020	(3) Max. 0.0039	
Stainless Steel	☆ 160 ~ 260	★ 160 ~ 260	(1) 0.0004 ~ 0.0012	(1) 0.0004 ~ 0.0012	(1) 0.0004 ~ 0.0012	
			(2) 0.0004 ~ 0.0012	(2) 0.0004 ~ 0.0012	(2) 0.0004 ~ 0.0012	
			(3) Max. 0.0020	(3) Max. 0.0020	(3) Max. 0.0039	

★ : 1st Recommendation ☆ : 2nd Recommendation

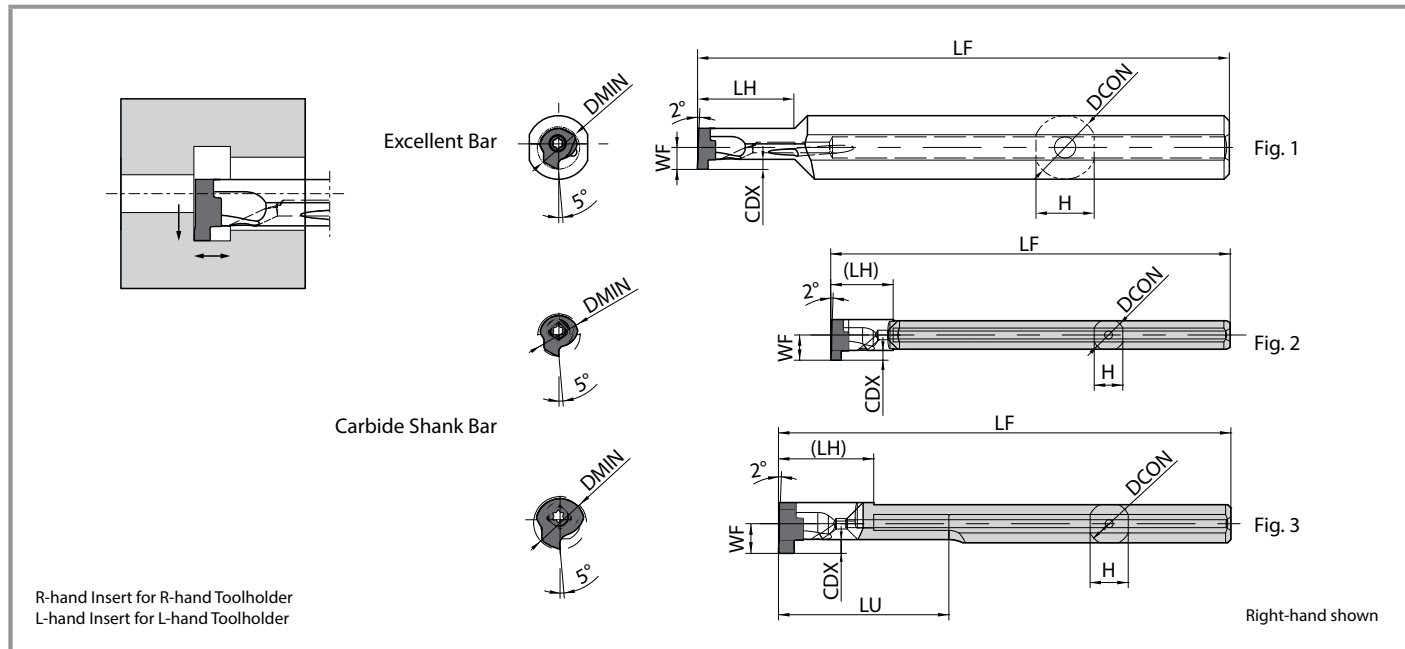

Toolholder Dimensions

Part Number	Stock		Min. Bore Dia.	Dimensions (mm)								Spare Parts		Applicable Insert	
	R	L		DMIN	DCON	H	LF	LU	LH	WF	CDX	Drawing	Clamp Screw		Wrench
SIGC $\frac{R}{L}$ 0812-EH	●	●	8	12	11	100	-	18	4.1	1.5	Fig.1	SB-2270T $\frac{R}{L}$	FT-7	GC08 $\frac{R}{L}$ 100-005 ~ GC08 $\frac{R}{L}$ 200-010	
SIGC $\frac{R}{L}$ 1016-EH	●	●	10	16	15	100	-	21	5.0	2.2		SB-3070T $\frac{R}{L}$	FT-8	GC10 $\frac{R}{L}$ 100-005 ~ GC10 $\frac{R}{L}$ 300-020	
SIGC $\frac{R}{L}$ 1216-EH	●	●	12	16	15	110	-	25	6.0	2.2		SB-3070T $\frac{R}{L}$	FT-8	GC12 $\frac{R}{L}$ 100-005 ~ GC12 $\frac{R}{L}$ 300-020	
SIGC $\frac{R}{L}$ 0806-WH	●	●	8	6	5.4	75	-	12	4.8	1.5	Fig.2	SB-2270T $\frac{R}{L}$	FT-7	GC08 $\frac{R}{L}$ 100-005 ~ GC08 $\frac{R}{L}$ 200-010	
SIGC $\frac{R}{L}$ 1008-WH-L85	●	●	10	8	7.2	85	32	18	5.6	2.2		Fig.3	SB-3070T $\frac{R}{L}$	FT-8	GC10 $\frac{R}{L}$ 100-005 ~ GC10 $\frac{R}{L}$ 300-020
SIGCR 1008-WH-L100	●					100	45				GC10R100-005 ~ GC10R300-020				
SIGCR 1210-WH-L95	●		12	10	9.2	95	32	GC12R100-005 ~ GC12R300-020							
SIGC $\frac{R}{L}$ 1210-WH-L110	●	●				110	45	6.6	GC12 $\frac{R}{L}$ 100-005 ~ GC12 $\frac{R}{L}$ 300-020						

● : Standard Item

Mounting Inserts

Use compressed air or other measures to remove chips or debris from the insert pocket
 Mount the insert into the toolholder and ensure the bottom makes contact with the end of the toolholder's surface
 Keeping the insert seated, tighten the insert clamp screw at an appropriate torque
 Recommended tightening torque for clamp screw: 0.8 Nm (SB-2270TR) 1.2 Nm (SB-3070TR)

L-hand clamp screw for L-hand Toolholders (See table to the right)

GC**R-***	GC**L-***
Right-hand screw	Left-hand screw
Toolholder : SIGCR****_* Insert : GC**R-*** Clamp Screw : SB-****TR	Toolholder : SIGCL****_* Insert : GC**L-*** Clamp Screw : SB-****TL

Applicable Sleeve

Applicable Sleeves. Please see the KYOCERA general product catalog for more details.

Shank Size (Diameter : mm)	06 (6 mm)	08 (8 mm)	10 (10 mm)	12 (12 mm)	16 (16 mm)
Toolholders	SIGC $\frac{R}{L}$ 0806-WH	SIGC $\frac{R}{L}$ 1008-WH-L85 SIGC $\frac{R}{L}$ 1008-WH-L100	SIGC $\frac{R}{L}$ 1210-WH-L95 SIGC $\frac{R}{L}$ 1210-WH-L110	SIGC $\frac{R}{L}$ 0812-EH	SIGC $\frac{R}{L}$ 1016-EH SIGC $\frac{R}{L}$ 1216-EH
SH Sleeve (for Boring Bars)	SH 06...	SH 08...	SH 10...	SH 12...	SH 16...
SHC Sleeve (for Coolant-Through)	-	SHC 08...	SHC 10...	SHC 12...	SHC 16...
SHA Sleeve	-	SHA 08...	SHA 10...	SHA 12...	-
EZH Sleeve (for EZ Bars)	EZH 06...ST/CT/HP...	EZH 08...ST/CT/HP...	-	-	-

Remove the positioning pin when mounting SIGC to the EZH-CT/HP Sleeve.
 (Positioning function is not available.)

Long tool life leads to improved cycle time
Excellent surface finish with no tearing lowers quality control costs

MEGACOAT NANO PLUS

AlTiN/AlCrN Nano laminated film with superior wear resistance and adhesion resistance. Excellent surface finish and long tool life.

Reduces Cracking

Reduces abnormal damages such as chipping because of increased lamination layer with a thinner gap than conventional coatings.

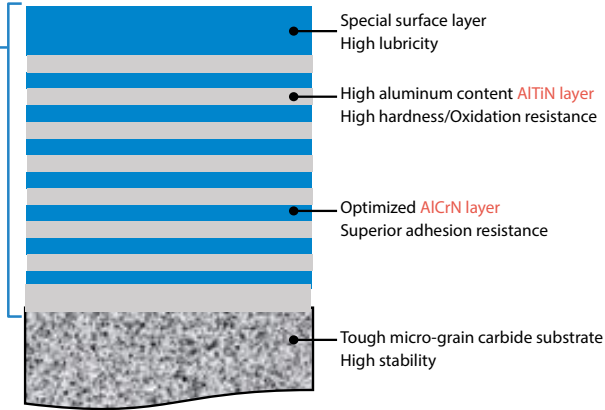

Wear Coefficient Comparison
(Internal Evaluation)

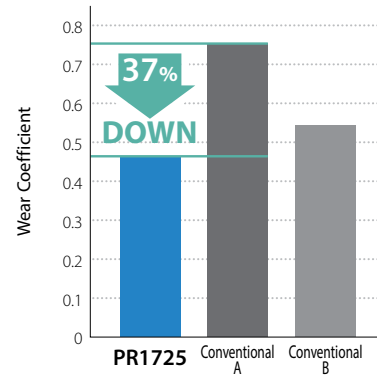

Superior Wear and Chipping Resistance

High hardness with nano laminated film layer properties
Internal stress optimization reduces chipping

Applicable to Various Workpiece Materials

Superior high temperature properties and oxidation
resistance make for great performance in steel, stainless
steel, and free cutting steel

Excellent Surface Finish

Special surface layer with great lubricity reduces adhesion.

High Machining Stability

Tough micro-grain carbide substrate provides stable
machining



KYOCERA Precision Tools

102 Industrial Park Road
Hendersonville, NC 28792
Customer Service | 800.823.7284 - Option 1
Technical Support | 800.823.7284 - Option 2



Official Website | www.kyoceraprecisiontools.com
Distributor Website | mykpti.kyocera.com
Email | cuttingtools@kyocera.com