

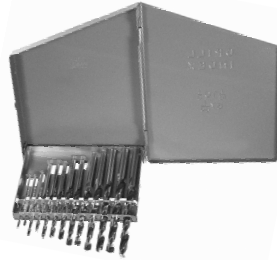

DRILL SETS

JOBBER LENGTH

13 Piece Set
1/16 -- 1/4 by 64^{ths}
in Metal Index
Case No. CZ13



Description	Set No.	Price Each
▶ HIGH SPEED STEEL		
Surface Treated 118° Point	307G	32.90
Bright Finish 118° Point	307GB	32.90
Heavy Duty 135° Split Point	307GH	34.50
Left Hand 118° Point	307GL	83.90
Type A 118° Split Point	307GHA	34.50
▶ TITANIUM COATED		
Gold Coated 118° Point	307TG	72.25
▶ COBALT		
Bronze 135° Split Point	307CG	55.00
● SOLID CARBIDE		
Micrograin	C800SG	316.75
● BLIZZARD BIT AND DOUBLE MARGIN		
Black and Gold 135° Split Point	307GQ	36.77
Double Margin 118° Split Point	314S13	36.00

15 Piece Set
1/16 -- 1/2 by 32^{nds}
in Metal Index
Case No. CZ15



Description	Set No.	Price Each
▶ HIGH SPEED STEEL		
Surface Treated 118° Point	307R	85.95
Bright Finish 118° Point	307RB	85.95
Reduced 3/8 Shank 118° Point	307RRS	105.00
Heavy Duty 135° Split Point	307RH	93.00
Left Hand 118° Point	307RL	211.30
▶ TITANIUM COATED		
Gold Coated 118° Point	307TR	196.00
▶ COBALT		
Bronze 135° Split Point	307CR	150.00
● SOLID CARBIDE		
Micrograin	C800SR	893.00
● BLIZZARD BIT AND DOUBLE MARGIN		
Black and Gold 135° Split Point	307RQ	107.29
Double Margin 118° Split Point	314S15	100.00

21 Piece Set
1/16 -- 3/8 by 64^{ths}
in Metal Index
Case No. CZ21



Description	Set No.	Price Each
▶ HIGH SPEED STEEL		
Surface Treated 118° Point	307S	77.50
Bright Finish 118° Point	307SY	77.50
Heavy Duty 135° Split Point	307SH	85.00
Left Hand 118° Point	307SL	196.46
▶ TITANIUM COATED		
Gold Coated 118° Point	307TS	187.67
▶ COBALT		
Bronze 135° Split Point	307CS	136.50
● BLIZZARD BIT AND DOUBLE MARGIN		
Black and Gold 135° Split Point	307SQ	95.83
Double Margin 118° Split Point	314S21	107.00

29 Piece Set
1/16 -- 1/2 by 64^{ths}
in Metal Index
Case No. CZ29

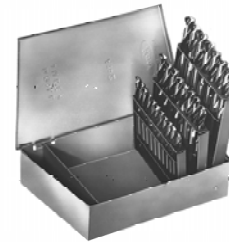

Description	Set No.	Price Each
▶ HIGH SPEED STEEL		
Surface Treated 118° Point	307F	160.00
Bright Finish 118° Point	307FB	160.00
Reduced 3/8 Shank 118° Point	308A	199.00
Reduced 1/4 Shank 118° Point	304A	230.00
Heavy Duty 135° Split Point	307FH	179.00
Type A 118° Split Point	307FHA	179.00
Fast Spiral 118° Point	307FF	211.50
Left Hand 118° Point	307FL	410.00
● HIGH SPEED STEEL		
Parabolic 135° Split Point	307FP	277.00
Double Margin 118° Split Point	314S29	188.00
Half Round 118° Point	307FHR	841.32
▶ TITANIUM COATED		
Gold Coated 118° Point	307TF	379.00
▶ COBALT		
Bronze 135° Split Point	307CF	288.00
● BLIZZARD BIT		
Black and Gold 135° Split Point	307FQ	201.00

DRILL SETS



JOBBER LENGTH

26 Piece Set
A -- Z Letter Sizes
in Metal Index
Case No. CZ26



Description	Set No.	Price Each
▶ HIGH SPEED STEEL		
Surface Treated 118° Point	307L	169.00
Bright Finish 118° Point	307LB	169.00
Left Hand 118° Point	307LL	419.72
▶ TITANIUM COATED		
Gold Coated 118° Point	307TL	307.00
▶ COBALT		
Bronze 135° Split Point	307CL	294.00

60 Piece Set
1-- 60 Wire Gauge
in Metal Index
Case No. CZ60

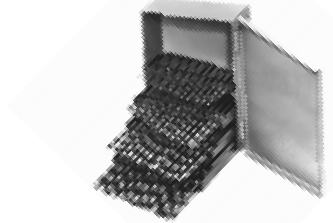

Description	Set No.	Price Each
▶ HIGH SPEED STEEL		
Surface Treated 118° Point	307W	123.00
Bright Finish 118° Point	307WB	123.00
Heavy Duty 135° Split Point	307WH	138.00
Left Hand 118° Point	307WL	350.74
▶ TITANIUM COATED		
Gold Coated 118° Point	307TW	332.00
▶ COBALT		
Bronze 135° Split Point	307CW	222.00

20 Piece Set
61-- 80 Wire Gauge
in Metal Index
Case No. CZ20



Description	Set No.	Price Each
▶ HIGH SPEED STEEL		
Surface Treated 118° Point	307V	47.50
Bright Finish 118° Point	307VB	47.50
▶ COBALT		
Bronze 135° Point	307CV	82.73

115 Piece Set
1/16 -- 1/2 by 64^{ths}
A -- Z Letter Sizes
1-- 60 Wire Gauge
in Metal Index
Case No. CZ115



Description	Set No.	Price Each
▶ HIGH SPEED STEEL		
Surface Treated 118° Point	307X	469.00
Bright Finish 118° Point	307XB	469.00
Heavy Duty 135° Split Point	307XH	516.99
▶ COBALT		
Bronze 135° Split Point	307CX	816.00
▶ TITANIUM COATED		
Gold Coated 118° Point	307TX	1027.00

135 Piece Set
1/16 -- 1/2 by 64^{ths}
A -- Z Letter Sizes
1-- 80 Wire Gauge
in Metal Index
Case No. CZ135



Description	Set No.	Price Each
▶ HIGH SPEED STEEL		
Surface Treated 118° Point	307Y	516.00
Bright Finish 118° Point	307YB	516.00
▶ COBALT		
Bronze 135° Split Point	307CY	878.00

TOOL CRIB SET

19 Piece Set
1/16, 5/64, 3/32, 1/8, #29, #25,
5/32, #21, 3/16, #7, 7/32, 1/4,
F, 5/16, U, 3/8, 27/64, 7/16, 1/2
in Metal Index
Case No. CZ119

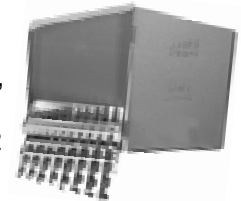

Description	Set No.	Price Each
▶ HIGH SPEED STEEL		
Surface Treated 118° Point	307J	87.90
Heavy Duty 135° Split Point	307JH	95.74
▶ COBALT		
Bronze 135° Split Point	307CJ	149.28



HIGH SPEED STEEL AND COBALT

DRILL SETS

METRIC JOBBER LENGTH

11 Piece Metric Set
1.00mm -- 6.00mm by .5mm
in Metal Index
Case No. CZM11



Description	Set No.	Price Each
● HIGH SPEED STEEL		
118° Point	307MA	29.86
● COBALT		
135° Split Point	307CMA	47.69

19 Piece Metric Set
1.00mm -- 10.00mm by .5mm
in Metal Index
Case No. CZM19



Description	Set No.	Price Each
● HIGH SPEED STEEL		
118° Point	307MB	81.00
● COBALT		
135° Split Point	307CMB	138.00

25 Piece Metric Set
1.00mm -- 13.00mm
by .5mm
in Metal Index
Case No. CZM25

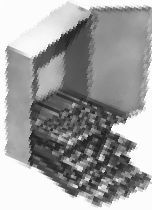

Description	Set No.	Price Each
● HIGH SPEED STEEL		
118° Point	307MD	159.00
● COBALT		
135° Split Point	307CMD	270.00

134 Piece Set
1.00mm -- 13.00mm by .5mm
1/16 -- 1/2 by 64^{ths}
1 -- 80 Wire Gauge
in Metal Index
Case No. CZ134



Description	Set No.	Price Each
● HIGH SPEED STEEL		
118° Point	307K	435.00
● COBALT		
135° Split Point	307CK	745.00

SCREW MACHINE LENGTH

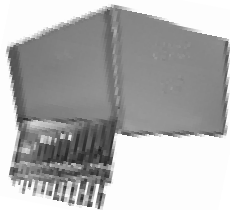

13 Piece Set
1/16 -- 1/4 by 64^{ths}
in Metal Index
Case No. CZ13S

Description	Set No.	Price Each
▶ HIGH SPEED STEEL		
Surface Treated 135° Split Point	607G	35.00
Bright Finish 118° Point	607GB	33.00
● COBALT		
Bronze 135° Split Point	607CG	49.00

33 Piece Set
1/2 -- 1" by 64^{ths}
in Metal Stand
Case No. CZ833

Description	Set No.	Price Each
▶ HIGH SPEED STEEL		
Bright Finish 118° Point	607H	1517.66

29 Piece Set
1/16 -- 1/2 by 64^{ths}
in Metal Index
Case No. CZ29S

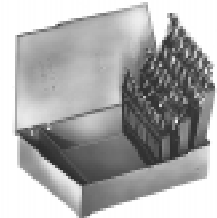

Description	Set No.	Price Each
▶ HIGH SPEED STEEL		
Surface Treated 135° Split Point	607F	155.00
Bright Finish 118° Point	607FB	154.00
● COBALT		
Bronze 135° Split Point	607CF	255.00



26 Piece Set
A -- Z Letter Sizes
in Metal Index
Case No. CZ26S

Description	Set No.	Price Each
▶ HIGH SPEED STEEL		
Surface Treated 135° Split Point	607L	171.44
Bright Finish 118° Point	607LB	165.37
● COBALT		
Bronze 135° Split Point	607CL	285.00

115 Piece Set
1/16 -- 1/2 by 64^{ths}
1 -- 60 Wire Gauge
A -- Z Letter Sizes
in Metal Index
Case No. CZ115S

Description	Set No.	Price Each
▶ HIGH SPEED STEEL		
Surface Treated 135° SP	607X	462.00
Bright Finish 118° Point	607XB	440.00
● COBALT		
Bronze 135° Split Point	607CX	741.00

60 Piece Set
1 -- 60 Wire Gauge
in Metal Index
Case No. CZ60S

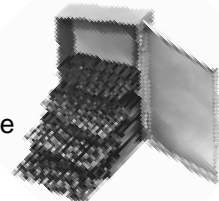

Description	Set No.	Price Each
▶ HIGH SPEED STEEL		
Surface Treated 135° Split Point	607W	117.00
Bright Finish 118° Point	607WB	110.00
● COBALT		
Bronze 135° Split Point	607CW	195.00

DRILL SETS

Silver and Deming

1/2" REDUCED SHANK DRILL SETS



8 Piece Set
9/16 — 1" by 16^{ths}
in Metal Index
Case No. CZ303



Description	Set No.	Price Each
▶ HIGH SPEED STEEL		
Round Shank	303SA	359.00
● HIGH SPEED STEEL		
Flatted Shank	303FSA	394.00
● COBALT		
Round Shank	303CA	624.00
Flatted Shank	303FCA	690.00

10 Piece Set
9/16 — 1" by 16^{ths},
1-1/8 and 1-1/4
in Wood Block

Description	Set No.	Price Each
▶ HIGH SPEED STEEL		
Round Shank	303SJ	539.00
● HIGH SPEED STEEL		
Flatted Shank	303FSJ	566.00
● COBALT		
135° Notched Point	303CS	1024.00

13 Piece Set
17/32 — 3/4 by 32^{nds}
13/16 — 1" by 16^{ths}, 31/32
in Wood Block



Description	Set No.	Price Each
▶ HIGH SPEED STEEL		
Round Shank	303SD	545.00
● HIGH SPEED STEEL		
Flatted Shank	303FSD	574.00
● COBALT		
135° Notched Point	303CD	959.00

8 Piece Set
1-1/16 — 1-1/2 by 16^{ths}
in Wood Block

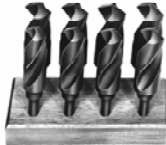

Description	Set No.	Price Each
▶ HIGH SPEED STEEL		
Round Shank	303SB	980.00
● HIGH SPEED STEEL		
Flatted Shank	303FSB	1029.00
● COBALT		
135° Notched point	303CB	2060.00

33 Piece Set
1/2 — 1" by 64^{ths}
in Metal Stand
Case No. CZ833S

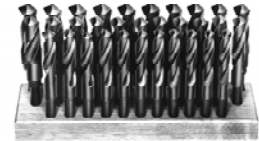

Description	Set No.	Price Each
▶ HIGH SPEED STEEL		
Round Shank	303SG	1460.00
● HIGH SPEED STEEL		
Flatted Shank	303SF	1524.00
● COBALT		
135° Notched Point	303CG	2485.00

3/4" REDUCED SHANK DRILL SETS
5 Piece Set
in Wood Block



Description	Set No.	Price Each
● HIGH SPEED STEEL		
13/16 — 1-1/16 by 16 ^{ths}	306G	340.00
1" — 1-1/2 by 8 ^{ths}	306A	625.00
1" — 2" by 1/4"	306B	939.00
● COBALT		
13/16 — 1-1/16 by 16 ^{ths}	306H	575.00
1" — 1-1/2 by 8 ^{ths}	306D	1185.00
1" — 2" by 1/4"	306E	1825.00

3/8" REDUCED SHANK DRILL SETS

8 Piece Set
in Wood Block

Description	Set No.	Price Each
▶ HIGH SPEED STEEL		
3/8 — 17/32 by 32 ^{nds} , 9/16, 5/8	308D	173.00
17/32 — 3/4 by 32 ^{nds}	308E	307.00
● COBALT		
3/8 — 17/32 by 32 ^{nds} , 9/16, 5/8	308CD	303.76

CARBIDE TIPPED BOWLING BALL DRILL SETS

in Wood Block



Description	Pieces Per Set	Set No.	Price Each
■ 1/2" STRAIGHT SHANK — SILVER AND DEMING			
5/8 — 1-1/8 by 32 ^{nds}	17	CT810S	540.00
7/16 — 1-1/8 by 32 ^{nds} , 61/64, 63/64, 1-1/64	23	CT810L	704.85
■ TAPER SHANK			
5/8 — 1-1/8 by 32 ^{nds}	17	CT811S	895.00
7/16 — 1-1/8 by 32 ^{nds} , 61/64, 63/64, 1-1/64	23	CT811L	1175.00

MASONRY DRILL SETS

Description	Pieces Per Set	Container	Set No.	Price Each
▶ 1/4, 5/16, 3/8, 1/2 by 4" Overall	4	Polytube	CT890S	25.00
5 pcs 1/4—1/2 by 16 ^{ths} HS (1/4" Shk) and 5 pcs 1/4—1/2 by 16 ^{ths} CT Masonry	10	Block	304B	85.00



HIGH SPEED STEEL AND COBALT

DRILL SETS

TAPER LENGTH

29 Piece Set
1/16 — 1/2 by 64^{ths}
in Metal Index
Case No. CZT29



Description	Set No.	Price Each
▶ HIGH SPEED STEEL		
Surface Treated 118° Point	407F	327.00
● COBALT		
Bronze 135° Split Point	407CF	672.00

16 Piece Set
Over 1/2" Diameter
in Metal Index
Case No. CZA16 or CZB16



Description	Set No.	Price Each
▶ HIGH SPEED STEEL		
33/64 - 3/4 by 64 ^{ths} 49/64 - 1" by 64 ^{ths}	407B 407C	746.00 1360.00

26 Piece Set
A — Z Letter Sizes
in Metal Index
Case No. CZT26



Description	Set No.	Price Each
▶ HIGH SPEED STEEL		
Surface Treated 118° Point	407L	420.00

60 Piece Set
1 — 60 Wire Gauge
in Metal Index
Case No. CZT60

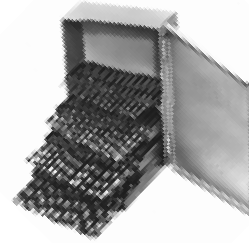

Description	Set No.	Price Each
▶ HIGH SPEED STEEL		
Surface Treated 118° Point	407W	512.00

TAPER SHANK

16 Piece Set
Over 1/2" Diameter
in Metal Index
Case No. CZA16 or CZB16



Description	Set No.	Price Each
▶ HIGH SPEED STEEL		
33/64 - 3/4 by 64 ^{ths} 49/64 - 1" by 64 ^{ths}	200A 200B	780.00 1326.00
● COBALT		
33/64 - 3/4 by 64 ^{ths} 49/64 - 1" by 64 ^{ths}	210CA 210CB	1371.54 2297.00

STANDARD STEP DRILLS

6 Piece Set
in Wood Block



Description	Set No.	Price Each
■ FLAT HEAD SCREW		
Jobber Length #6 — 3/8 NC Screw Sizes Cobalt Jobber Length #6 — 3/8 Screw Sizes	372S 372CS	158.35 285.00
■ CAP SCREW		
Jobber Length #6 — 3/8 NC Screw Sizes Taper Length #6 — 3/8 NC Screw Size Metric Jobber Length 3mm — 10mm Screw Sizes Cobalt Jobber Length #6 — 3/8 Screw Sizes	371S 471S 371MS 371CS	127.52 185.65 145.00 230.00
■ TAP DRILL		
Jobber Length #6 — 3/8 NC Tap Sizes Taper Length #6 — 3/8 NC Tap Sizes Metric Jobber Length 3mm — 10mm Tap Sizes Cobalt Jobber Length #6 — 3/8 NC Tap Sizes	370S 470S 370MS 370CS	98.16 146.93 104.00 228.00

29 Piece Set
1/16 — 1/2 by 64^{ths}
in Metal Stand
Case No. CZ829

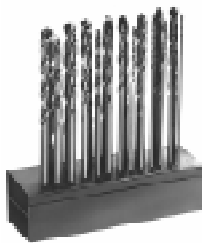

Description	Set No.	Price Each
▶ HIGH SPEED STEEL		
6" Overall Length 12" Overall Length	906SFA 912SF	435.00 642.00
● COBALT		
12" Overall Length	912CSF	1034.00

AIRCRAFT EXTENSION DRILLS

26 Piece Set
A — Z Letter Sizes
in Metal Stand
Case No. CZ826

Description	Set No.	Price Each
▶ HIGH SPEED STEEL		
6" Overall Length 12" Overall Length	906SL 912SL	500.67 677.32

60 Piece Set
1 — 60 Wire Gauge
in Metal Stand
Case No. CZ860

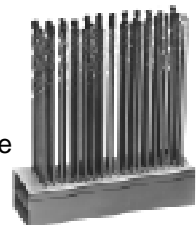

Description	Set No.	Price Each
▶ HIGH SPEED STEEL		
6" Overall Length 12" Overall Length	906SW 912SW	330.00 848.00

DRILL SETS



DRILL AND REAMER BLANKS

29 Piece Set
1/16 — 1/2 by 64^{ths}
in Metal Index
Case No. CZ29

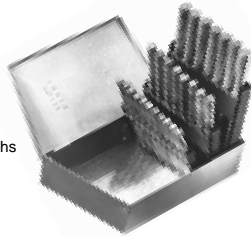

Description	Set No.	Price Each
▶ HIGH SPEED STEEL		
Drill Blanks	950SF	250.00
● HIGH SPEED STEEL		
Reamer Blanks	950SR	250.00

26 Piece Set
A — Z Letter Sizes
in Metal Index
Case No. CZ26

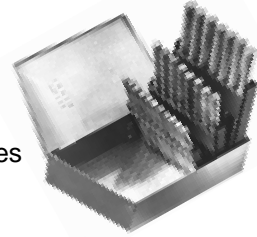

Description	Set No.	Price Each
▶ HIGH SPEED STEEL		
Drill Blanks	950SL	227.39

20 Piece Set
61 — 80 Wire Gauge
in Metal Index
Case No. CZ20

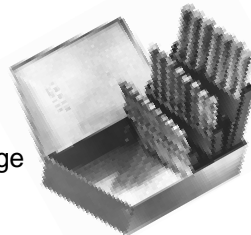

Description	Set No.	Price Each
▶ HIGH SPEED STEEL		
Drill Blanks	950ST	55.80

60 Piece Set
1 — 60 Wire Gauge
in Metal Index
Case No. CZ60

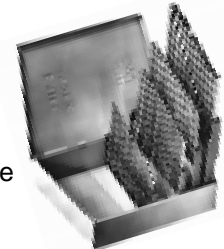

Description	Set No.	Price Each
▶ HIGH SPEED STEEL		
Drill Blanks	950SW	195.25

115 Piece Set
1/16 — 1/2 by 64^{ths}
1 — 60 Wire Gauge
A — Z Letter Sizes
in Metal Index
Case No. CZ115

Description	Set No.	Price Each
▶ HIGH SPEED STEEL		
Drill Blanks	950SX	695.00

HALF ROUND DRILLS

29 Piece Set
1/16 — 1/2 by 64^{ths}
in Metal Index
Case No. CZ29

Description	Set No.	Price Each
● HIGH SPEED STEEL		
Half Round Drills	307FHR	841.32

EXTRA LENGTH DRILLS - STRAIGHT SHANK "LONGBOYS"

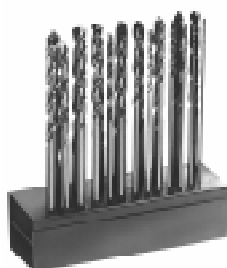

Description	Pieces Per Set	Case No.	Set No.	Price Each
▶ HIGH SPEED STEEL				
8" Overall Length 1/8 — 3/8 by 16ths	5	Wood Block	208EA	104.50
8" Overall Length 1/8 — 3/8 by 64ths	17	CZ829	208ES	365.00
8" Overall Length 1/8 — 1/2 by 64ths	25	CZ829	208EB	649.87
10" Overall Length 1/8 — 1/2 by 16ths	7	Wood Block	208BEA	192.86
10" Overall Length 1/8 — 1/2 by 64ths	25	CZ829	208BEB	748.02
12" Overall Length 1/8 — 1/2 by 16ths	7	Wood Block	212EA	251.00
12" Overall Length 1/8 — 1/2 by 64ths	25	CZ829	212ES	918.00
● HIGH SPEED STEEL				
18" Overall Length 3/16 — 1/2 by 32nds	11	CZ829	218ES	623.00





COUNTERSINK SETS

COUNTERSINK

5 Piece Set
in Wood Block

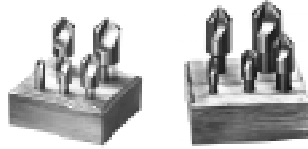

Description	High Speed Set No.	Price Each	Cobalt Set No.	Price Each
CENTER REAMERS—THREE FLUTE				
Each 5 Piece Set includes: 1/4, 3/8, 1/2, 5/8, 3/4	Degrees			
	60°	480S5	97.20	—
	82°	481S5	97.20	481CS5 175.00
	90°	482S5	97.20	—
100°	483S5	97.20	—	
CHATTERLESS—SIX FLUTE				
Each 5 Piece Set includes: 1/4, 3/8, 1/2, 5/8, 3/4	60°	495S5	125.00	—
	82°	496S5	125.00	—
	90°	497S5	125.00	—
	100°	498S5	125.00	—
MACHINE COUNTERSINKS—SINGLE FLUTE				
Each 5 Piece Set includes: 1/4, 3/8, 1/2, 5/8, 3/4	60°	490S5	120.50	—
	82°	491S5	120.50	491CS5 217.00
	90°	492S5	120.50	—
	100°	493S5	120.50	—

COUNTERSINK

9 Piece Set
in Wood Block

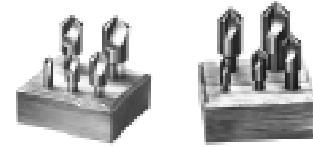

Description	High Speed Set No.	Price Each	Cobalt Set No.	Price Each
CENTER REAMERS—THREE FLUTE				
Each 9 Piece Set includes: 1/4, 3/8, 1/2, 5/8, 3/4, 1, 1-1/4, 1-1/2, 2	Degrees			
	60°	480S9	545.10	—
	82°	481S9	545.10	481CS9 980.91
90°	482S9	545.10	—	
MACHINE COUNTERSINKS—SINGLE FLUTE				
Each 9 Piece Set includes: 1/4, 3/8, 1/2, 5/8, 3/4, 1, 1-1/4, 1-1/2, 2	60°	490S9	667.00	—
	82°	491S9	667.00	491CS9 1200.00
	90°	492S9	667.00	—
	100°	493S9	667.00	—

COUNTERSINK

8 Piece Set
in Wood Block



Description	High Speed Set No.	Price Each
CHATTERLESS—SIX FLUTE		
Each 8 Piece Set includes: 1/4, 5/16, 3/8, 1/2, 5/8, 3/4, 7/8, 1	Degrees	
	60°	495S8 255.00
	82°	496S8 255.00
	90°	497S8 255.00
	100°	498S8 255.00

COUNTERSINK AND DEBURRING

5 Piece Set
in Wood Block

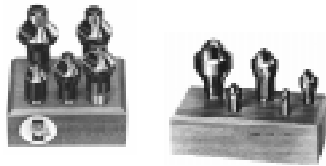

Description	High Speed Set No.	Price Each	Cobalt Set No.	Price Each
PILOTED				
Set includes: #11, #13, #15, #17, #19	Degrees			
	82°	544PS	105.50	—
PILOTLESS				
Each 5 Piece Set includes: #0, #1, #2, #3, #4	60°	543S	87.82	—
	82°	544S	84.80	544CS 152.64
	90°	546S	84.80	546CS 152.64
	100°	547S	89.42	—

8 Piece Set — in Wood Block

Description	Set No.	Price Each
PILOTLESS		
Set includes: #0, #1, #2, #3, #4, #5, #6, #7	Degrees	
	82°	544T 413.80

COUNTERSINK

12 Piece Set
in Wood Block

Description	High Speed Set No.	Price Each
MACHINE COUNTERSINKS—SINGLE FLUTE		
Each 12 Piece Set includes: 3/16, 1/4, 5/16, 3/8, 1/2, 5/8, 3/4, 7/8, 1, 1-1/4, 1-1/2, 2	Degrees	
	60°	490S12 746.50
	82°	491S12 746.50
	90°	492S12 746.50
	100°	493S12 746.50

COMBINED DRILL AND COUNTERSINK

5 Piece Set
in Wood Block

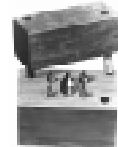

Description	Set No.	Price Each
HIGH SPEED STEEL		
Plain Type — 1 — 5 Import	585P5	30.40
Bell Type — 11 — 15 Bell	587B	42.47
HIGH SPEED STEEL		
Plain Type — 1 — 5 USA	585UP5	35.90
Plain Type — 1 — 5 Tin Coated	585PTIN	41.94
COBALT		
Plain Type — 1 — 5 Import	585CP	93.43
Plain Type — 1 — 5 USA	585CUP	110.00
SOLID CARBIDE—USA		
Plain Type — 1 — 5	585CS5	228.00

8 Piece Set — in Wood Block

Description	Set No.	Price Each
HIGH SPEED STEEL		
Plain Type — 1 — 8 Import	585P8	88.78
HIGH SPEED STEEL		
Plain Type — 1 — 8 USA	585UP8	108.65

END MILL SETS



Sets Furnished in Wood Block

241A
3/8" Shank 4 Flute
Double-End

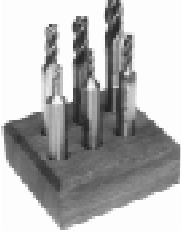

TC-151
Cobalt T-15

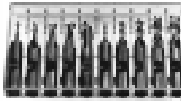

205CA
Four Flute - 3/8" Shank

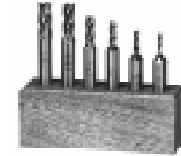

CRS2
Cobalt Roughers

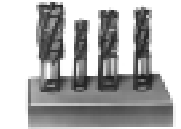

231S
2 Flute
Regular Length

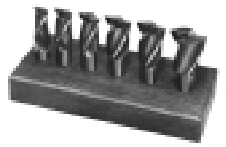

231A
3/8" Shank - 2 Flute

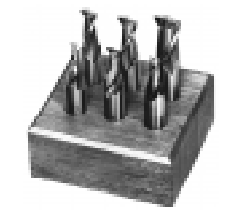

205S
4 Flute - 3/4" Shank

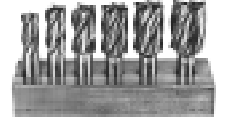

245CA
Miniature Cobalt
Double-End

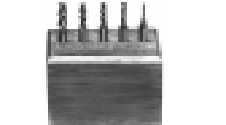

Description	Pieces Per Set	Quality Import		Made in U.S.A.	
		Set No.	Price Each	Set No.	Price Each
HIGH SPEED STEEL					
SINGLE END — TWO FLUTE REGULAR LENGTH					
3/8 Shank 1/8, 3/16, 1/4, 5/16, 3/8, 1/2	6	231A	89.00	231AU	103.00
3/4 Shank 3/4, 7/8, 1, 1-1/8, 1-1/4, 1-1/2	6	231S	349.00	231SU	459.00
SINGLE END — MULTI-FLUTE REGULAR LENGTH					
3/8 Shank 1/8, 3/16, 1/4, 5/16, 3/8, 1/2	6	205A	88.50	205AU	110.00
3/4 Shank 3/4, 7/8, 1, 1-1/8, 1-1/4, 1-1/2	6	205S	363.50	205SU	445.00
DOUBLE END					
Two Flute, 3/8 Shank 1/8, 5/32, 3/16, 1/4, 5/16, 3/8	6	261A	117.00	261AU	148.00
Two Flute, 1/8, 3/16, 1/4, 5/16, 3/8, 1/2x1/2	6	261B	128.00	—	—
Four Flute, 3/8 Shank 1/8, 5/32, 3/16, 1/4, 5/16, 3/8	6	241A	119.00	241AU	137.00
Four Flute, Center Cut 1/8, 5/32, 3/16, 1/4, 5/16, 3/8	6	242A	147.00	242AU	180.00
Four Flute, 1/8, 3/16, 1/4, 5/16, 3/8, 1/2x1/2	6	241B	128.00	—	—
BALL END					
Two Flute 1/8, 3/16, 1/4, 5/16, 3/8, 1/2	6	291AS	137.40	291AUS	155.12
HIGH SPEED STEEL					
DOUBLE END — MINIATURE REGULAR LENGTH					
Two Flute, 3/16 Shank 1/16, 3/32, 1/8, 5/32, 3/16	5	265A	87.50	—	—
Four Flute, 3/16 Shank 1/16, 3/32, 1/8, 5/32, 3/16	5	245A	84.50	—	—
CORNER ROUNDING END MILL					
1/16 - 3/8 Radius 1/16, 3/32, 1/8, 5/32, 3/16, 1/4x1/2, 5/16x1/2, 3/8x1/2	8	282A	559.00	—	—
COBALT					
COBALT ROUGHER END MILLS					
Mini-Set 1/4, 5/16, 3/8, 1/2	4	CRS-1	177.00	—	—
Bridgeport Set 1/2, 5/8, 3/4x3/4, 1x3/4	4	CRS-2	339.00	CRSU-2	361.00
COBALT					
COBALT T-15					
Two and Four Flute 1/8, 3/16, 1/4, 5/16, 3/8	10	TC-151	369.00	—	—
M-42 COBALT, Center Cut					
Four Flute Double End 1/8, 3/16, 1/4, 5/16, 3/8, 1/2	6	241CS	195.00	—	—
Four Flute Single End 1/8, 3/16, 1/4, 5/16, 3/8, 1/2	6	205CA	140.25	—	—
DOUBLE END — MINIATURE REGULAR LENGTH					
Two Flute, 3/16 Shank 1/16, 3/32, 1/8, 5/32, 3/16	5	265CA	149.00	—	—
Four Flute, 3/16 Shank 1/16, 3/32, 1/8, 5/32, 3/16	5	245CA	149.00	—	—
TITANIUM NITRIDE COATED					
SINGLE END — TWO FLUTE REGULAR LENGTH					
3/8 Shank 1/8, 3/16, 1/4, 5/16, 3/8, 1/2	6	231AT	125.00	231ATU	184.00
3/4 Shank 3/4, 7/8, 1, 1-1/8, 1-1/4, 1-1/2	6	231ST	475.00	231STU	665.00
SINGLE END — MULTI-FLUTE REGULAR LENGTH					
3/8 Shank 1/8, 3/16, 1/4, 5/16, 3/8, 1/2	6	205AT	125.00	205ATU	172.00
3/4 Shank 3/4, 7/8, 1, 1-1/8, 1-1/4, 1-1/2	6	205ST	522.30	205STU	751.00
DOUBLE END					
Two Flute, 3/8 Shanks 1/8, 5/32, 3/16, 1/4, 5/16, 3/8	6	261AT	199.20	261ATU	249.00
Four Flute, 3/8 Shanks 1/8, 5/32, 3/16, 1/4, 5/16, 3/8	6	241AT	199.70	241ATU	249.00

6 Piece Sets		
All sets below contain 1 piece of each: 1/8, 3/16, 1/4, 5/16, 3/8, 1/2 in Wood Case		
USA SOLID MICROGRAIN CARBIDE		
Description	Set No.	Price Each
2 Flute Single End Regular Length	KS92S	161.25
4 Flute Single End Regular Length	KS94S	161.25
2 Flute Double End - Stub	KD92S	205.65
4 Flute Double End - Stub	KD94S	205.65
2 Flute Ball Single End	KB92S	207.30
4 Flute Ball Single End	KB94S	207.30
2 Flute Ball Double End - Stub	KB82S	260.60
4 Flute Ball Double End - Stub	KB84S	260.60
USA SOLID MICROGRAIN CARBIDE COATED		
2 Flute Single End TiN Coated	KST92S	229.95
4 Flute Single End TiN Coated	KST94S	229.95
2 Flute Single End TiAlN Coated	KSTLN92S	259.50
4 Flute Single End TiAlN Coated	KSTLN94S	259.50
USA TITANIUM ALUMINUM NITRIDE COATED		
SINGLE END — MULTI-FLUTE		
3/8 Shank 1/8, 3/16, 1/4, 5/16, 3/8, 1/2	205ATAU	215.00
SINGLE END — MULTI-FLUTE		
3/4 Shank 3/4, 7/8, 1, 1-1/8, 1-1/4, 1-1/2	205STAU	841.00
SINGLE END		
Two Flute, 3/8 Shank 1/8, 3/16, 1/4, 5/16, 3/8, 1/2	231ATAU	209.00
Two Flute, 3/4 Shank 3/4, 7/8, 1, 1-1/8, 1-1/4, 1-1/2	231STAU	761.00
DOUBLE END — REGULAR LENGTH		
Two Flute, 3/8 Shank 1/8, 5/32, 3/16, 1/4, 5/16, 3/8	261ATAU	337.00
Four Flute, 3/8 Shank 1/8, 5/32, 3/16, 1/4, 5/16, 3/8	241ATAU	340.00

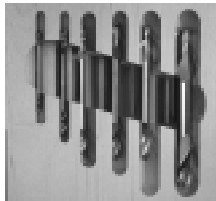

2 Flute - Double End
KD92S

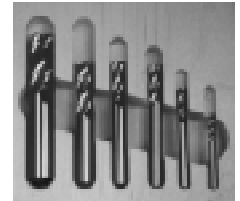

4 Flute - Single End
KS94S



SETS

REAMERS — HIGH SPEED STEEL

Description	Pieces Per Set	Case No.	Set No.	Price Each	
▶ CHUCKING REAMER - STRAIGHT SHANK - STRAIGHT FLUTE					
Fractional 1/16 — 1/2 by 64ths	29	CZ129	550SF	678.12	
Letter A — Z	26	CZ126	550SL	688.65	
Wire Gauge 1 — 60	60	Pouch	550SW	1024.70	
Over and Under .1240 — .5010	14	CZ112	550SX	338.35	
Dowel Pin .1230 — .4995	14	CZ114	550SD	338.45	
■ USA STRAIGHT SHANK ALIGNING REAMER					
Fractional 1/2, 9/16, 5/8, 3/4	4	Block	535RS	199.00	
▶ HAND REAMER STRAIGHT FLUTE					
Straight Flute 1/4, 3/8, 1/2, 5/8, 3/4	5	Block	564S	349.00	
Spiral Flute 1/4, 3/8, 1/2, 5/8, 3/4	5	Block	565S	384.99	
▶ HAND EXPANSION REAMER STRAIGHT FLUTE					
Straight Flute 1/4, 3/8, 1/2, 5/8, 3/4	5	Block	576S	575.00	
Spiral Flute 1/4, 3/8, 1/2, 5/8, 3/4	5	Block	577S	599.00	
▶ ADJUSTABLE HAND REAMER					
1/4 — 3/8	8A — 5A	8	Block	570A	649.99
15/32 — 1-1/16 Range	A — H	4	Block	570B	249.00
15/32 — 1-1/2	A — K	11	Block	570C	1075.00

550SF Fractional Straight Shank Chucking Reamer Set



SCREW EXTRACTORS

5 Piece Set, in Handy Pouch

MADE IN USA

Description	Set No.	Price Each
Straight Flute #1 — 5	EXT15	13.95
Helical Flute #1 — 5	EXL15	13.95

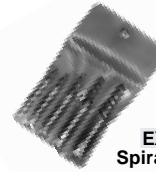

EXL15 Spiral Flute Set

CBS8 8 Piece



USA CARBIDE BUR BOX SETS — DOUBLE CUT

Description	Pieces Per Set	Set No.	Price Each
• SA1, SC1, SD1, SE1, SF1, SG1, SH1, SJ1, SK1, SL1, SM1, SN1	12	CBS12	146.00
• SA51, SB51, SC51, SD51, SE51, SF51, SG51, SM51, SN51	9	CBS9	80.10
• SA1, SA3, SC1, SC3, SD1, SD3, SF1, SF3	8	CBS8	99.00

CBS12 12 Piece



785A 16 Piece Combination of Set 775S & 785S



TAPS — HIGH SPEED STEEL

Description	Pieces Per Set	Case No.	Set No.	Price Each
◆ USA HAND TAPS				
Taper, Plug and Bott. NC 4-40 thru 1/2-13 and 10-32	33	Block	770S	149.95
● .005 OVER SIZE TAPS				
Hand Tap NC 6-32 thru 1/2-13 and 10-32 (Excludes 7/16)	8	Block	775S	83.00
Spiral Pointed NC 6-32 thru 1/2-13 and 10-32 (Excludes 7/16)	8	Block	785S	98.00
Combination Combination of Set 775S & 785S	16	Block	785A	182.00
◆ USA TAP AND DRILL SETS				
Frac. & Mach. Screw 6-32 to 1/2-13	16	Pouch	770R	49.95
Frac. & Mach. Screw 6-32 to 1/2-13	18	CZTD18	770X	72.50
Metric Taps 3x 0.5mm to 12x 1.75mm, Drill 2.5 to 10.25mm	16	Pouch	773S	74.50
● USA HIGH SPEED PIPE TAPS				
Fractional 1/8 — 1"	6	Block	790US	388.15
● USA CARBON PIPE TAPS				
Fractional 1/8 — 1"	6	Block	793US	151.09
■ USA "THREDRILL" COMBINED TAP AND DRILL				
Fractional 8-32, 10-24, 10-32, 1/4-20, 5/16-18, 3/8-16	6	Pouch	789S	110.00
● HEX DIES				
Fractional 1/4-20, 5/16-18, 3/8-16, 7/16-14, 1/2-13	5	Plastic box	765S	81.20
Fractional 1/4-20, 5/16-18, 3/8-16, 7/16-14, 1/2-13, 9/16-12, 5/8-11, 3/4-10	8	Plastic box	765S1	155.80

770S 33 Piece Hand Tap Set



770X Fractional and Machine Screw Size Tap and Drill Set



773S Metric Tap and Drill Set



◆ HUOT METAL CASES

MADE IN U.S.A.

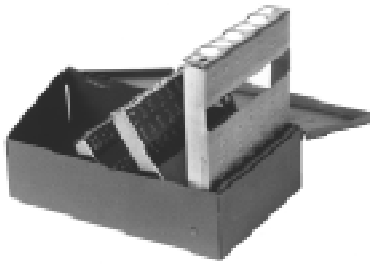

JOBBER LENGTH INDEXES

Description	Pieces Per Set	Case No.	Price Each
Fractional 1/16 — 1/2 by 64ths	29	CZ29	9.45
Fractional 1/16 — 1/4 by 64ths	13	CZ13	4.25
Fractional 1/16 — 1/4 by 64ths hang-up	13	CZ13H	3.00
Fractional 1/16 — 3/8 by 64ths	21	CZ21	7.75
Fractional 1/64 — 1/4 by 64ths	16	CZ16	11.30
Fractional 1/16 — 1/2 by 32nds	15	CZ15	7.75
Fractional 1/16 — 1/4 by 64ths and 9/32 — 1/2 by 32nds	21	CZ21A	7.75
Letter A — Z	26	CZ26	9.45
Wire Gauge 1 — 60	60	CZ60	8.10
Wire Gauge 1 — 80	80	CZ80	19.40
Wire Gauge 61 — 80	20	CZ20	5.40
Metric 1.0mm — 5.9 mm by .1mm	50	CZM50	10.50
Metric 1.0mm — 6.0 mm by .5mm	11	CZM11	6.70
Metric 1.0mm — 7.0 mm by .5mm	13	CZM13	6.95
Metric 1.0mm — 10.0 mm by .5mm	19	CZM19	9.45
Metric 1.0mm — 13.0 mm by .5mm	25	CZM25	9.45
Metric 6.0mm — 10.0 mm by .1mm	41	CZM41	25.00

TAPER LENGTH INDEXES

Description	Pieces Per Set	Case No.	Price Each
Fractional 1/16 — 1/2 by 64ths	29	CZT29	27.70
Letter A — Z	26	CZT26	27.70
Wire Gauge 1 — 60	60	CZT60	30.30

TAPER LENGTH / TAPER SHANK INDEXES

Description	Pieces Per Set	Case No.	Price Each
Fractional 33/64 — 3/4 by 64ths	16	CZA16	63.80
Fractional 49/64 — 1" by 64ths	16	CZB16	71.50

SCREW MACHINE LENGTH INDEXES

Description	Pieces Per Set	Case No.	Price Each
Fractional 1/16 — 1/2 by 64ths	29	CZ29S	15.20
Fractional 1/16 — 3/8 by 64ths	21	CZ21S	12.75
Fractional 1/16 — 1/4 by 64ths	13	CZ13S	7.00
Letter A — Z	26	CZ26S	17.30
Wire Gauge 1 — 60	60	CZ60S	14.00
Metric 1.0mm — 13.0mm by .5mm	25	CZM25S	17.30

COMBINATION INDEXES

Description	Pieces Per Set	Case No.	Price Each
JOBBER LENGTH			
Frac. 1/16 — 1/2 by 64ths, A — Z, 1 — 60	115	CZ115	37.80
Frac. 1/16 — 1/2 by 64ths, A — Z, 1 — 80	135	CZ135	43.00
Frac. 1/16 — 1/2 by 64ths, 1 — 80, 1mm — 13mm by .5mm	134	CZ134	43.00
Metric 1.0mm — 13.0mm	118	CZM118	66.00
SCREW MACHINE			
Frac. 1/16 — 1/2 by 64ths, A — Z, 1 — 60	115	CZ115S	43.80

1/2" SHANK — SILVER AND DEMING INDEXES

Description	Pieces Per Set	Case No.	Price Each
1/2" Shank — S&D 9/16 — 1" by 16ths	8	CZ303	27.30

TAP INDEXES

Description	Pieces Per Set	Case No.	Price Each
NC and NF 1/4-20 To 1/2-20	10	CZTD10	12.60
10 Taps 0-80 to 12-28, 9 Taps 1/64 to 12-24	19	CZTD19	12.60
NC 4-40 to 5/8-11	10	CZT10	14.70

REAMER INDEXES

Description	Pieces Per Set	Case No.	Price Each
Fractional 1/16 — 1/2 by 64ths	29	CZ129	25.00
Letter A — Z	26	CZ126	25.00
Wire Gauge 1 — 60	60	CZ160	29.40
Over and Under .1240 — .5010	14	CZ112	25.00
Dowel Pin .1230 — .4995	14	CZ114	25.00
Metric 1.0mm — 13.0mm by .5mm	25	CZ125	33.60

SCREW EXTRACTOR INDEX

Description	Pieces Per Set	Case No.	Price Each
1-5 Screw Extractor and Matching Drill	10	CZ10	5.25

TAP AND DRILL INDEXES

Description	Pieces Per Set	Case No.	Price Each
NC 6-32 to 1/2-13 Taps, #36 to 27/64 Drills Holds 9 Drills and 9 Taps	18	CZTD18	10.50
NF 6-40 to 1/2-20 Taps, #33 to 1/2 Drills Holds 9 Drills and 9 Taps	18	CZTD99	10.50
Combination of both models above in one case; holds 18 Drills and 18 Taps	36	CZTD36	42.00
2.5mmX.45 to 12.0mmX1.75 Taps, 2.05mm to 10.2 Drills. Holds 9 Drills and 9 Taps	18	CZTD99M	11.55

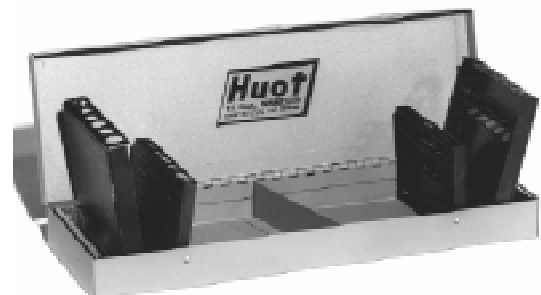



◆ HUOT DISPENSER CABINETS AND DRILL DISPLAYS

MADE IN U.S.A



DRILL DISPENSER CABINETS—All Steel

Description	Case No.	Price Each
Fractional 1/16 — 1/2 by 64ths Jobber	CZD1	77.00
Wire Gauge 1 — 60 Jobber	CZD2	98.00
Letter A — Z Jobber	CZD3	77.00
Metric 1.0mm — 13.0mm by .5mm Jobber	CZD4	79.00
Metric 1.0mm — 6.9mm by .1mm Jobber	CZD5	99.00
Combination 1/16 — 1/2 by 64ths, A — Z, 1 — 60	CZD6	336.00
Taper Lng/Shk, 1/8 — 1" by 64ths	CZD57	345.00
Fractional 1/16 — 1/2 by 64ths Stubs	CZD15	79.00
Wire Gauge 1 — 60 Stubs	CZD16	99.00
Silver and Deming 33/64 — 1-1/2	CZD303	576.00

TAP DISPENSER CABINETS—All Steel

Description	Case No.	Price Each
Metric 3mm — 24.0mm	CZD7	79.00
Fractional 1/4-20 — 1"-14 by 64ths	CZD8	79.00
Machine Screw 2-56 — 12-28	CZD9	98.00
Combination NC & NF taps 1/4 to 1-1/2, 2-56 to 12-28, 2.5mm — 30mm	CZD19	336.00
Combination 1/4-20 to 1-14 taper, plug, & bottoming, 2-56 — 12-28 taper, plug, bottoming & spiral point	CZD21	389.00
Tap/Drill Comb. 6-32 to 1/2-20, #36 to 29/64 Taps and Corresponding Drills	CZD20	77.00



END MILL DISPENSER CABINETS—All Steel

Description	Case No.	Price Each
Two Flute Single and Double End 1/16 to 1"	CZD10	299.00
Four FLute Single and Double End 1/16 to 1"	CZD11	299.00
Two and Four Flute Single and Double End 1/8 to 1"	CZD12	77.00

REAMER DISPENSERS—All Steel

Description	Case No.	Price Each
Fractional 1/16 — 1/2 by 64ths	CZD410	90.00
Wire Gauge 1 — 60	CZD420	98.00
Letter A — Z	CZD425	79.00
Over & Under, Dowel .124 - .501, .123 - .4995	CZD430	77.00

CARBIDE INSERT DISPENSER CABINETS—All Steel

Description	Case No.	Price Each
Triangle, Square, Diamond, and Round	CZD14	345.00

CARBIDE BUR DISPENSER—All Steel

Description	Case No.	Price Each
Cylindrical, Ball, Cone, Tree/Pointed, Oval, Cone/Flat end, Tree/Rad	CZD132	78.00



POINT OF PURCHASE DRILL AND TAP DISPLAYS

DISPLAYS—COUNTERTOP

Description	Case No.	Price Each
Fractional 1/16 — 1/2 by 64ths	CZD60	149.00
Letter A — Z	CZD70	149.00
Wire Gauge 1 — 60	CZD80	250.00
Tap and Die 4 - 40 — 3/4, 1/8 Pipe	CZD90	199.00

◆ HUOT METAL STANDS

MADE IN USA

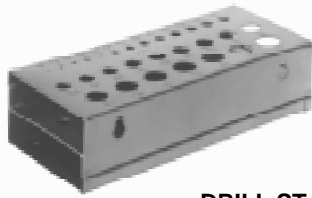

DRILL STANDS

Description	Pieces Per Stand	Stand No.	Price Each
STANDARD SHANKS STAND			
Fractional 1/16 — 1/2 by 64ths	29	CZ829	5.60
Fractional 1/2 — 1" by 64ths	33	CZ833	42.75
Letter A — Z	26	CZ826	5.60
Wire Gauge 1 — 60	60	CZ860	5.60
1/2" SHANK — SILVER AND DEMING			
Frac. 1/2 — 1" by 64ths for 1/2" Shanks	33	CZ833S	39.00

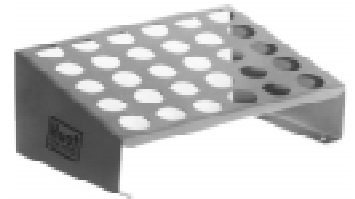

COLLET STANDS - HEAVY DUTY STEEL

Description	Pieces Per Stand	Stand No.	Price Each
5C Collet Stands Holds 30 5C Collets	30	CZ5C	23.50
R-8 Collet Stands Holds 16 R-8 Collets	16	CZR8	23.50

◆ DRILL GAUGES



Description	Order No.	Price Each
Fractional 1/16 — 1/2 by 64ths	CZG29	3.25
Wire Gauge 1 — 60	CZG60	3.75
Fractional 1/2 — 1" by 64ths	CZG30	7.60

◆ COLLET STANDS

**18 Hole 5C
Wood Collet Block
Tool No. BLK 5C
Price Each \$28.00**

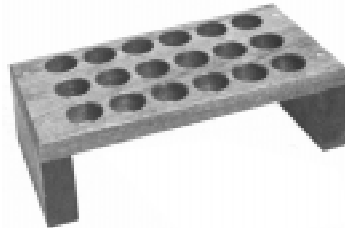

**14 Hole R8
Wood Collet Block
Tool No. BLK R8
Price Each \$26.00**

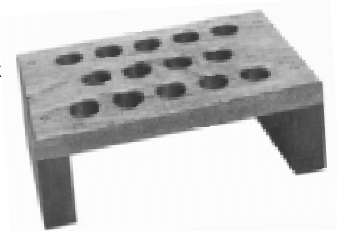

◆ CNC TOOL CART

Dimensions: 18"W x 35-1/4"L x 35"H
Weight: 75 LBS

- Keeps tools organized and helps protect from damage
- Heavy gauge — All steel infrared baked epoxy finish
- Angled tray for easy, quick tool access from side
- 2 Storage trays with protective lining
- Durable nylon inserts to protect tools
- Heavy duty 5" x 1-1/4" casters, load rated at 1,000 lbs.



Description	Tool Taper	Pieces Per Stand	Order No.	Price Each
BT,CAT "V" Flange, NMTB	30	48	CZ13930	469.95
BT	35	48	CZ13935	469.95
BT,CAT "V" Flange, NMTB	40	48	CZ13940	469.95
BT,CAT "V" Flange	45	36	CZ13945	469.95
BT,CAT "V" Flange, NMTB	50	36	CZ13950	469.95

◆ NC TOOLHOLDER STORAGE TOWER

Dimensions: 27-5/16"W x 18-5/16"D x 36"H
Weight: 65 LBS

- Stackable and durable 16 gauge steel
- Complete with 3 shelves that can be stacked to form a 5 or 6 shelf tower



Description	Tool Taper	Pieces Per Stand	Order No.	Price Each
BT,CAT "V" Flange, NMTB	30	72	CZ13830	359.00
BT,CAT "V" Flange, NMTB	40	72	CZ13840	359.00
BT,CAT "V" Flange, NMTB	50	54	CZ13850	359.00



JOBBER LENGTH DRILLS

GENERAL PURPOSE, 118° POINT

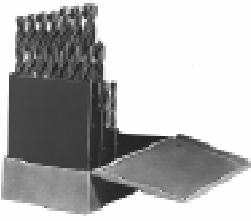

SET NO. 307L

26 Piece High Speed
Surface Treated Set
A-Z Letter Sizes in Metal Index
SET PRICE — \$169.00

SET NO. 307LB

26 Piece Bright Finish Set
A-Z Letter Sizes in Metal Index
SET PRICE — \$169.00

- ▶ **LIST NO. 300 — OXIDE FINISH**
Creates a porous layer that holds cutting oil which provides abrasion resistance and improved chip flow.
- ▶ **LIST NO. 300A — BRIGHT FINISH**
Better chip ejection in low carbon, non-ferrous materials.
- ▶ **LIST NO. 300T — TITANIUM NITRIDE COATED**
For best wear resistance and better lubrication of tool surface which reduces heat and tendency to chip weld.

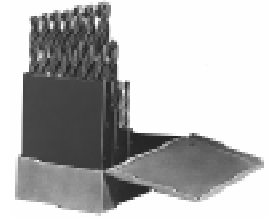

SET NO. 307F

29 Piece High Speed
Surface Treated Set
1/16 - 1/2 x 64ths in Metal Index
SET PRICE — \$160.00

SET NO. 307FB

29 Piece Bright Finish Set
1/16 - 1/2 x 64ths in Metal Index
SET PRICE — \$160.00

Please order in package quantity.



FRACTIONAL SIZES

Size	Dec. Equiv.	Flute Length	Overall Length	Pkg. Qty.	Price Each		
					Oxide Finish 300	Bright Finish 300A	Titanium Nitride Coated 300T
1/64	.0156	3/16	3/4	12	2.61	2.61	6.10
1/32	.0312	1/2	1-3/8	12	1.59	1.59	6.10
3/64	.0469	3/4	1-3/4	12	1.52	1.52	6.10
1/16	.0625	7/8	1-7/8	12	1.57	1.57	3.92
5/64	.0781	1	2	12	1.57	1.57	3.92
3/32	.0938	1-1/4	2-1/4	12	1.57	1.57	3.92
7/64	.1094	1-1/2	2-5/8	12	1.63	1.63	3.99
1/8	.1250	1-5/8	2-3/4	12	1.63	1.63	4.95
9/64	.1406	1-3/4	2-7/8	12	1.80	1.80	5.40
5/32	.1562	2	3-1/8	12	1.83	1.83	5.40
11/64	.1719	2-1/8	3-1/4	12	1.98	1.98	5.60
3/16	.1875	2-5/16	3-1/2	12	2.22	2.22	6.29
13/64	.2031	2-7/16	3-5/8	12	2.44	2.44	6.62
7/32	.2188	2-1/2	3-3/4	12	2.72	2.72	6.94
15/64	.2344	2-5/8	3-7/8	12	2.95	2.95	7.22
1/4	.2500	2-3/4	4	12	2.99	2.99	7.29
17/64	.2656	2-7/8	4-1/8	12	3.76	3.76	11.40
9/32	.2812	2-15/16	4-1/4	6	3.88	3.88	11.60
19/64	.2969	3-1/16	4-3/8	6	4.48	4.48	11.90
5/16	.3125	3-3/16	4-1/2	6	4.96	4.96	12.40
21/64	.3281	3-5/16	4-5/8	6	5.50	5.50	15.69
11/32	.3438	3-7/16	4-3/4	6	6.14	6.14	16.46
23/64	.3594	3-1/2	4-7/8	6	6.91	6.91	17.38

Size	Dec. Equiv.	Flute Length	Overall Length	Pkg. Qty.	Price Each		
					Oxide Finish 300	Bright Finish 300A	Titanium Nitride Coated 300T
3/8	.3750	3-5/8	5	6	7.07	7.07	18.10
25/64	.3906	3-3/4	5-1/8	6	8.09	8.09	21.80
13/32	.4062	3-7/8	5-1/4	6	8.31	8.31	22.10
27/64	.4219	3-15/16	5-3/8	6	9.23	9.23	22.22
7/16	.4375	4-1/16	5-1/2	6	9.59	9.59	23.42
29/64	.4531	4-3/16	5-5/8	6	10.72	10.72	24.59
15/32	.4688	4-5/16	5-3/4	6	11.39	11.39	25.38
31/64	.4844	4-3/8	5-7/8	6	11.97	11.97	26.34
1/2	.5000	4-1/2	6	6	12.04	12.04	26.34
33/64	.5156	4-13/16	6-5/8	1	21.69	21.69	47.65
17/32	.5312	4-13/16	6-5/8	1	22.33	22.33	49.10
35/64	.5469	4-13/16	6-5/8	1	24.62	24.62	54.20
9/16	.5625	4-13/16	6-5/8	1	25.28	25.28	55.62
37/64	.5781	4-13/16	6-5/8	1	25.86	25.86	56.90
19/32	.5938	5-3/16	7-1/8	1	26.55	26.55	58.50
39/64	.6094	5-3/16	7-1/8	1	28.44	28.44	62.57
5/8	.6250	5-3/16	7-1/8	1	27.92	27.92	61.40
41/64	.6406	5-3/16	7-1/8	1	30.47	30.47	63.00
21/32	.6562	5-3/16	7-1/8	1	31.94	31.94	69.00
43/64	.6719	5-5/8	7-5/8	1	34.53	34.53	72.00
11/16	.6875	5-5/8	7-5/8	1	34.53	34.53	72.00
23/32	.7188	5-5/8	7-5/8	1	42.80	42.80	79.00
3/4	.7500	5-5/8	7-5/8	1	45.37	45.37	85.00

LETTER SIZES

Size	Dec. Equiv.	Flute Length	Overall Length	Pkg. Qty.	Price Each		
					Oxide Finish 300	Bright Finish 300A	Titanium Nitride Coated 300T
A	.2340	2-5/8	3-7/8	12	3.74	3.74	7.80
B	.2380	2-3/4	4	12	3.74	3.74	7.80
C	.2420	2-3/4	4	12	3.74	3.74	7.80
D	.2460	2-3/4	4	12	3.74	3.74	7.80
E	.2500	2-3/4	4	12	2.99	2.99	7.29
F	.2570	2-7/8	4-1/8	12	3.97	3.97	11.40
G	.2610	2-7/8	4-1/8	12	4.47	4.47	11.40
H	.2660	2-7/8	4-1/8	12	4.47	4.47	11.40
I	.2720	2-7/8	4-1/8	6	4.47	4.47	11.40
J	.2770	2-7/8	4-1/8	6	4.80	4.80	11.40
K	.2810	2-15/16	4-1/4	6	5.30	5.30	11.40
L	.2900	2-15/16	4-1/4	6	5.30	5.30	11.40
M	.2950	3-1/16	4-3/8	6	5.60	5.60	11.92

Size	Dec. Equiv.	Flute Length	Overall Length	Pkg. Qty.	Price Each		
					Oxide Finish 300	Bright Finish 300A	Titanium Nitride Coated 300T
N	.3020	3-1/16	4-3/8	6	5.60	5.60	12.42
O	.3160	3-3/16	4-1/2	6	5.67	5.67	12.42
P	.3230	3-5/16	4-5/8	6	6.39	6.39	14.00
Q	.3320	3-7/16	4-3/4	6	6.39	6.39	14.00
R	.3390	3-7/16	4-3/4	6	6.84	6.84	14.00
S	.3480	3-1/2	4-7/8	6	7.24	7.24	14.00
T	.3580	3-1/2	4-7/8	6	8.24	8.24	18.10
U	.3680	3-5/8	5	6	8.24	8.24	18.10
V	.3770	3-5/8	5	6	8.47	8.47	20.85
W	.3860	3-3/4	5-1/8	6	8.75	8.75	21.85
X	.3970	3-3/4	5-1/8	6	10.61	10.61	22.05
Y	.4040	3-7/8	5-1/4	6	11.92	11.92	22.50
Z	.4130	3-7/8	5-1/4	6	12.69	12.69	23.70

JOBBER LENGTH DRILLS

GENERAL PURPOSE, 118° POINT

- ▶ LIST NO. 300 — OXIDE FINISH
- ▶ LIST NO. 300A — BRIGHT FINISH
- ▶ LIST NO. 300T — TITANIUM NITRIDE COATED

Please order in package quantity.

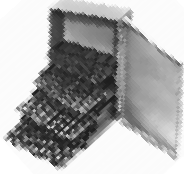

SET NO. 307W
 60 Piece High Speed Surface Treated Set
 No. 1 - 60 with Metal Index
SET PRICE — \$123.00

SET NO. 307WB
 60 Piece Bright Finish Set
 No. 1 - 60 with Metal Index
SET PRICE — \$123.00

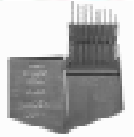

SET NO. 307V
 20 Piece High Speed Surface Treated Set
 No. 61 - 80 with Metal Index
SET PRICE — \$47.50

SET NO. 307VB
 20 Piece Bright Finish Set
 No. 61 - 80 with Metal Index
SET PRICE — \$47.50

WIRE GAUGE SIZES

12 DRILLS PER PACKAGE

Size	Dec. Equiv.	Flute Length	Overall Length	Price Each		
				Oxide Finish 300	Bright Finish 300A	Titanium Nitride Coated 300T
1	.2280	2-5/8	3-7/8	3.27	3.27	7.65
2	.2210	2-5/8	3-7/8	3.31	3.31	7.65
3	.2130	2-1/2	3-3/4	2.97	2.97	7.27
4	.2090	2-1/2	3-3/4	3.02	3.02	7.27
5	.2055	2-1/2	3-3/4	3.02	3.02	7.27
6	.2040	2-1/2	3-3/4	3.02	3.02	7.27
7	.2010	2-7/16	3-5/8	2.63	2.63	6.83
8	.1990	2-7/16	3-5/8	2.66	2.66	6.83
9	.1960	2-7/16	3-5/8	2.66	2.66	6.83
10	.1935	2-7/16	3-5/8	2.64	2.64	6.83
11	.1910	2-5/16	3-1/2	2.44	2.44	6.62
12	.1890	2-5/16	3-1/2	2.46	2.46	6.62
13	.1850	2-5/16	3-1/2	2.41	2.41	6.56
14	.1820	2-3/16	3-3/8	2.41	2.41	6.56
15	.1800	2-3/16	3-3/8	2.41	2.41	6.56
16	.1770	2-3/16	3-3/8	2.41	2.41	6.56
17	.1730	2-3/16	3-3/8	2.41	2.41	6.56
18	.1695	2-1/8	3-1/4	2.00	2.00	6.05
19	.1660	2-1/8	3-1/4	1.98	1.98	6.05
20	.1610	2-1/8	3-1/4	1.98	1.98	6.05
21	.1590	2-1/8	3-1/4	1.83	1.83	5.86
22	.1570	2	3-1/8	1.85	1.85	5.86
23	.1540	2	3-1/8	1.82	1.82	5.84
24	.1520	2	3-1/8	1.82	1.82	5.84
25	.1495	1-7/8	3	1.74	1.74	5.72
26	.1470	1-7/8	3	1.76	1.76	5.72
27	.1440	1-7/8	3	1.75	1.75	5.72
28	.1405	1-3/4	2-7/8	1.61	1.61	5.57
29	.1360	1-3/4	2-7/8	1.60	1.60	5.57
30	.1285	1-5/8	2-3/4	1.60	1.60	5.57
31	.1200	1-5/8	2-3/4	1.59	1.59	4.53
32	.1160	1-5/8	2-3/4	1.59	1.59	4.53
33	.1130	1-1/2	2-5/8	1.59	1.59	4.53
34	.1110	1-1/2	2-5/8	1.59	1.59	4.53
35	.1100	1-1/2	2-5/8	1.59	1.59	4.53
36	.1065	1-7/16	2-1/2	1.59	1.59	4.53
37	.1040	1-7/16	2-1/2	1.59	1.59	4.53
38	.1015	1-7/16	2-1/2	1.59	1.59	4.53
39	.0995	1-3/8	2-3/8	1.59	1.59	4.53
40	.0980	1-3/8	2-3/8	1.59	1.59	4.53
41	.0960	1-3/8	2-3/8	1.59	1.59	4.30
42	.0935	1-1/4	2-1/4	1.59	1.59	4.30
43	.0890	1-1/4	2-1/4	1.59	1.59	4.30
44	.0860	1-1/8	2-1/8	1.59	1.59	4.30
45	.0820	1-1/8	2-1/8	1.59	1.59	4.30
46	.0810	1-1/8	2-1/8	1.59	1.59	4.30
47	.0785	1	2	1.59	1.59	4.30
48	.0760	1	2	1.59	1.59	4.30
49	.0730	1	2	1.59	1.59	4.30

Size	Dec. Equiv.	Flute Length	Overall Length	Price Each		
				Oxide Finish 300	Bright Finish 300A	Titanium Nitride Coated 300T
50	.0700	1	2	1.59	1.59	4.30
51	.0670	1	2	1.59	1.59	4.30
52	.0635	7/8	1-7/8	1.59	1.59	4.30
53	.0595	7/8	1-7/8	1.59	1.59	4.30
54	.0550	7/8	1-7/8	1.59	1.59	4.30
55	.0520	7/8	1-7/8	1.59	1.59	4.30
56	.0465	3/4	1-3/4	1.59	1.59	4.30
57	.0430	3/4	1-3/4	1.59	1.59	4.30
58	.0420	11/16	1-5/8	1.63	1.63	4.30
59	.0410	11/16	1-5/8	1.63	1.63	4.30
60	.0400	11/16	1-5/8	1.63	1.63	4.30
61	.0390	11/16	1-5/8	1.73	1.73	4.40
62	.0380	5/8	1-1/2	1.73	1.73	4.40
63	.0370	5/8	1-1/2	1.73	1.73	4.40
64	.0360	5/8	1-1/2	1.73	1.73	4.40
65	.0350	5/8	1-1/2	1.73	1.73	4.40
66	.0330	1/2	1-3/8	1.73	1.73	4.40
67	.0320	1/2	1-3/8	1.73	1.73	4.40
68	.0310	1/2	1-3/8	1.73	1.73	4.40
69	.0292	1/2	1-3/8	1.89	1.89	4.50
70	.0280	3/8	1-1/4	1.89	1.89	4.50
71	.0260	3/8	1-1/4	2.36	2.36	5.70
72	.0250	5/16	1-1/8	2.36	2.36	5.70
73	.0240	5/16	1-1/8	2.36	2.36	5.70
74	.0225	1/4	1	2.36	2.36	5.70
75	.0210	1/4	1	2.36	2.36	5.70
76	.0200	3/16	7/8	2.36	2.36	5.70
77	.0180	3/16	7/8	2.36	2.36	5.70
78	.0160	3/16	7/8	2.36	2.36	5.70
79	.0145	1/8	3/4	2.83	2.83	6.03
80	.0135	1/8	3/4	2.83	2.83	6.03
81	.0130	3/32	3/4	—	5.74	—
82	.0125	3/32	3/4	—	5.74	—
83	.0120	3/32	3/4	—	6.61	—
84	.0115	3/32	3/4	—	6.61	—
85	.0110	5/64	3/4	—	6.61	—
86	.0105	5/64	3/4	—	7.32	—
87	.0100	5/64	3/4	—	7.32	—
88	.0095	5/64	3/4	—	9.28	—
89	.0091	1/16	3/4	—	9.28	—
90	.0087	1/16	3/4	—	9.28	—
91	.0083	1/16	3/4	—	9.28	—
92	.0079	1/16	3/4	—	9.28	—
93	.0075	1/16	3/4	—	9.28	—
94	.0071	1/16	3/4	—	13.36	—
95	.0067	1/16	3/4	—	13.36	—
96	.0063	3/64	3/4	—	14.71	—
97	.0059	3/64	3/4	—	14.71	—

◆ **PIN CHUCK SET**
SET NO. PV30

Designed for holding small drills
 One Pin Chuck with 3
 interchangeable collets
 0 - 1/32, 1/32 - 1/16, 1/16 - 3/32
SET PRICE — \$7.45



◆ **MICRO CHUCK**
TOOL NO. PV10

Suitable for 61-80 drills
 Can be held in any
 1/8 or 3/16 collet or
 larger adjustable drill chuck.
PRICE EACH — \$5.90





BLIZZARD BIT™



MADE OF PREMIUM HIGH SPEED STEEL

"You have seen the rest, now try the best"

135° SPLIT POINT HEAVY DUTY JOBBER LENGTH DRILL

● LIST NO. 300Q



- Tests show the "BLIZZARD BIT" out performs all other high speed steel 135° split point heavy duty drills.
- Made of proprietary steel that keeps the drill cooler than all other high speed steels.
- Runs at higher feeds and speeds than other high speed steel drills.
- Priced at high speed but performs similarly to cobalt.
- Improved lubricity of the drill, due to a special oxide and gold finish.
- Centers quickly with 135° split point.
- Heavy duty construction allows for hand held jobs or shop production.

Size	Dec. Equiv.	Flute Length	Overall Length	Pkg. Qty.	Price Each	Size	Dec. Equiv.	Flute Length	Overall Length	Pkg. Qty.	Price Each	Size	Dec. Equiv.	Flute Length	Overall Length	Pkg. Qty.	Price Each
1/16	.0625	7/8	1-7/8	12	1.59	7/32	.2188	2-1/2	3-3/4	12	3.42	3/8	.3750	3-5/8	5	6	8.76
5/64	.0781	1	2	12	1.78	15/64	.2344	2-5/8	3-7/8	12	3.61	25/64	.3906	3-3/4	5-1/8	6	10.27
3/32	.0938	1-1/4	2-1/4	12	1.78	1/4	.2500	2-3/4	4	12	3.88	13/32	.4062	3-7/8	5-1/4	6	10.59
7/64	.1094	1-1/2	2-5/8	12	1.78	17/64	.2656	2-7/8	4-1/8	12	4.74	27/64	.4219	3-15/16	5-3/8	6	11.69
1/8	.1250	1-5/8	2-3/4	12	2.05	9/32	.2812	2-15/16	4-1/4	6	5.71	7/16	.4375	4-1/16	5-1/2	6	12.61
9/64	.1406	1-3/4	2-7/8	12	2.05	19/64	.2969	3-1/16	4-3/8	6	6.16	29/64	.4531	4-3/16	5-5/8	6	14.43
5/32	.1562	2	3-1/8	12	2.33	5/16	.3125	3-3/16	4-1/2	6	6.35	15/32	.4688	4-5/16	5-3/4	6	14.79
11/64	.1719	2-1/8	3-1/4	12	2.37	21/64	.3281	3-5/16	4-5/8	6	6.99	31/64	.4844	4-3/8	5-7/8	6	14.79
3/16	.1875	2-5/16	3-1/2	12	2.78	11/32	.3438	3-7/16	4-3/4	6	7.77	1/2	.5000	4-1/2	6	6	15.48
13/64	.2031	2-7/16	3-5/8	12	3.10	23/64	.3594	3-1/2	4-7/8	6	8.68						

HIGH SPEED STEEL

PRODUCTION MAX™

TIGHT TOLERANCE DRILLS

118° SPLIT POINT BLACK AND GOLD DOUBLE MARGIN JOBBER LENGTH DRILL

● LIST NO. 314

- Precision hole drilling.
- Oxide and gold modified 118° split point for reduced thrust, quick centering.
- Produces straighter, rounder holes with up to 300% tighter hole tolerances.
- Eliminates reaming in some applications.
- Not recommended for hand held drilling.



Size	Dec. Equiv.	Flute Length	Overall Length	Pkg. Qty.	Price Each	Size	Dec. Equiv.	Flute Length	Overall Length	Pkg. Qty.	Price Each	Size	Dec. Equiv.	Flute Length	Overall Length	Pkg. Qty.	Price Each
1/16*	.0625	7/8	1-7/8	12	1.75	7/32	.2188	2-1/2	3-3/4	12	3.28	3/8	.3750	3-5/8	5	6	8.49
5/64*	.0781	1	2	12	1.75	15/64	.2344	2-5/8	3-7/8	12	3.52	25/64	.3906	3-3/4	5-1/8	6	9.38
3/32*	.0938	1-1/4	2-1/4	12	1.75	1/4	.2500	2-3/4	4	12	3.65	13/32	.4062	3-7/8	5-1/4	6	9.77
7/64*	.1094	1-1/2	2-5/8	12	1.82	17/64	.2656	2-7/8	4-1/8	12	4.66	27/64	.4219	3-15/16	5-3/8	6	10.73
1/8*	.1250	1-5/8	2-3/4	12	2.00	9/32	.2812	2-15/16	4-1/4	6	5.01	7/16	.4375	4-1/16	5-1/2	6	11.32
9/64*	.1406	1-3/4	2-7/8	12	2.21	19/64	.2969	3-1/16	4-3/8	6	5.60	29/64	.4531	4-3/16	5-5/8	6	12.56
5/32*	.1562	2	3-1/8	12	2.30	5/16	.3125	3-3/16	4-1/2	6	5.87	15/32	.4688	4-5/16	5-3/4	6	13.57
11/64*	.1719	2-1/8	3-1/4	12	2.47	21/64	.3281	3-5/16	4-5/8	6	6.49	31/64	.4844	4-3/8	5-7/8	6	14.10
3/16	.1875	2-5/16	3-1/2	12	2.65	11/32	.3438	3-7/16	4-3/4	6	7.19	1/2	.5000	4-1/2	6	6	14.39
13/64	.2031	2-7/16	3-5/8	12	3.12	23/64	.3594	3-1/2	4-7/8	6	8.00						

* Size not Double Margin.

Available in Titanium Coating for increased lubricity and extended wear.



SETS

Description	Pieces Per Set	PRODUCTION MAX™ SET No.	Price Each	BLIZZARD™ SET No.	Price Each
Fractional 1/16 — 1/2 by 64ths	29	314S29	188.00	307FQ	201.00
Fractional 1/16 — 1/4 by 64ths	13	314S13	36.00	307GQ	36.77
Fractional 1/16 — 3/8 by 64ths	21	314S21	107.00	307SQ	95.83
Fractional 1/16 — 1/2 by 32nds	15	314S15	100.00	307RQ	107.29

HALF ROUND JOBBER DRILLS

● LIST NO. 300HR

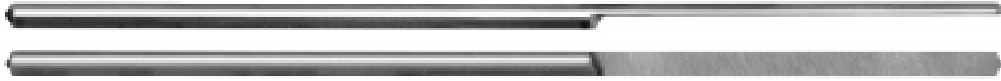

These drills allow greater chip clearance and have less tendency to run out in deep hole drilling operations. As a result, hole sizes are more accurate. They can be used in drilling brass, copper, hard rubber, fiberglass and other materials.

FRACTIONAL SIZES

Size	Dec. Equiv.	Flute Length	Overall Length	Price Each
1/16	.0625	7/8	1-7/8	8.50
5/64	.0781	1	2	8.50
3/32	.0938	1-1/4	2-1/4	8.50
7/64	.1094	1-1/2	2-5/8	9.05
1/8	.1250	1-5/8	2-3/4	9.63
9/64	.1406	1-3/4	2-7/8	9.63
5/32	.1562	2	3-1/8	9.95
11/64	.1719	2-1/8	3-1/4	10.97
3/16	.1875	2-5/16	3-1/2	11.95
13/64	.2031	2-7/16	3-5/8	13.95

Size	Dec. Equiv.	Flute Length	Overall Length	Price Each
7/32	.2188	2-1/2	3-3/4	15.06
15/64	.2344	2-5/8	3-7/8	16.50
1/4	.2500	2-3/4	4	17.07
17/64	.2656	2-7/8	4-1/8	21.30
9/32	.2812	2-15/16	4-1/4	21.90
19/64	.2969	3-1/16	4-3/8	25.50
5/16	.3125	3-3/16	4-1/2	26.90
21/64	.3281	3-5/16	4-5/8	30.52
11/32	.3438	3-7/16	4-3/4	33.15
23/64	.3594	3-1/2	4-7/8	38.34

Size	Dec. Equiv.	Flute Length	Overall Length	Price Each
3/8	.3750	3-5/8	5	38.34
25/64	.3906	3-3/4	5-1/8	44.74
13/32	.4062	3-7/8	5-1/4	44.90
27/64	.4219	3-15/16	5-3/8	51.68
7/16	.4375	4-1/16	5-1/2	51.50
29/64	.4531	4-3/16	5-5/8	59.92
15/32	.4688	4-5/16	5-3/4	61.17
31/64	.4844	4-3/8	5-7/8	67.00
1/2	.5000	4-1/2	6	65.75

WIRE GAUGE SIZES

Size	Dec. Equiv.	Flute Length	Overall Length	Price Each
1	.2280	2-5/8	3-7/8	13.70
2	.2210	2-5/8	3-7/8	13.70
3	.2130	2-1/2	3-3/4	12.22
4	.2090	2-1/2	3-3/4	12.22
5	.2055	2-1/2	3-3/4	12.22
6	.2040	2-1/2	3-3/4	12.22
7	.2010	2-7/16	3-5/8	10.85
8	.1990	2-7/16	3-5/8	10.85
9	.1960	2-7/16	3-5/8	10.85
10	.1935	2-7/16	3-5/8	10.85
11	.1910	2-5/16	3-1/2	10.85
12	.1890	2-5/16	3-1/2	10.85
13	.1850	2-5/16	3-1/2	9.59
14	.1820	2-3/16	3-3/8	9.59
15	.1800	2-3/16	3-3/8	9.59
16	.1770	2-3/16	3-3/8	9.59
17	.1730	2-3/16	3-3/8	9.59
18	.1695	2-1/8	3-1/4	9.03
19	.1660	2-1/8	3-1/4	9.03

Size	Dec. Equiv.	Flute Length	Overall Length	Price Each
20	.1610	2-1/8	3-1/4	9.03
21	.1590	2-1/8	3-1/4	9.03
22	.1570	2	3-1/8	9.03
23	.1540	2	3-1/8	8.80
24	.1520	2	3-1/8	8.80
25	.1495	1-7/8	3	8.80
26	.1470	1-7/8	3	8.80
27	.1440	1-7/8	3	8.80
28	.1405	1-3/4	2-7/8	8.80
29	.1360	1-3/4	2-7/8	8.80
30	.1285	1-5/8	2-3/4	8.80
31	.1200	1-5/8	2-3/4	8.21
32	.1160	1-5/8	2-3/4	8.21
33	.1130	1-1/2	2-5/8	8.21
34	.1110	1-1/2	2-5/8	8.21
35	.1100	1-1/2	2-5/8	8.21
36	.1065	1-7/16	2-1/2	7.70
37	.1040	1-7/16	2-1/2	7.70
38	.1015	1-7/16	2-1/2	7.70

Size	Dec. Equiv.	Flute Length	Overall Length	Price Each
39	.0995	1-3/8	2-3/8	7.70
40	.0980	1-3/8	2-3/8	7.70
41	.0960	1-3/8	2-3/8	7.86
42	.0935	1-1/4	2-1/4	7.86
43	.0890	1-1/4	2-1/4	7.86
44	.0860	1-1/8	2-1/8	7.86
45	.0820	1-1/8	2-1/8	7.86
46	.0810	1-1/8	2-1/8	7.86
47	.0785	1	2	7.86
48	.0760	1	2	7.86
49	.0730	1	2	7.86
50	.0700	1	2	7.86
51	.0670	1	2	7.86
52	.0635	7/8	1-7/8	7.86
56	.0465	3/4	1-3/8	7.86
57	.0430	3/4	1-3/8	7.86
59	.0410	11/16	1-5/8	7.86
60	.0400	11/16	1-5/8	7.86

VENT DRILLS

FAST SPIRAL

■ LIST NO. 380

To drill vent holes in tire molds and to clean the vent holes after tire production.

Size	Dec. Equiv.	Flute Length	Overall Length	Price Each
74	.0225	1	2	3.99
74	.0225	1	3	4.40
73	.0240	5/8	1-1/2	4.20
69	.0292	2	3	4.75
68	.0320	2	6	7.20
60	.0400	1-1/2	2-1/2	3.65
60	.0400	3	4	4.50
60	.0400	4	6	5.95
58	.0420	2	3	4.25
58	.0420	3	4	4.75
57	.0430	2	3	3.95

Size	Dec. Equiv.	Flute Length	Overall Length	Price Each
57	.0430	2-1/2	3-1/2	4.50
57	.0430	3	4	4.90
57	.0430	4	6	6.24
3/64	.0469	2	3	4.10
55	.0520	2-1/4	3	4.25
55	.0520	2-1/2	4-1/2	5.20
55	.0520	3	4	4.99
55	.0520	3-1/2	6-1/4	6.95
54	.0550	4	6	6.50
1/16	.0625	2-1/2	3-1/2	4.71
1/16	.0625	3	4	5.12

Size	Dec. Equiv.	Flute Length	Overall Length	Price Each
1/16	.0625	4	6	6.95
1/16	.0625	5	7	8.20
52	.0635	4	5	6.00
51	.0670	2	3	4.50
50	.0700	2-1/2	4-1/2	5.65
50	.0700	3	4	5.26
50	.0700	3	5	6.10
50	.0700	4	6	7.20
45	.0820	2	3	5.50
45	.0820	2-1/4	4-1/2	6.72
3/32	.0938	4	6	7.50

MAINTENANCE JOBBER LENGTH DRILLS

A.I.A. (NAS907) — STANDARD — OXIDE FINISH

► LIST NO. X300SB, 135° SPLIT POINT HEAVY DUTY WEB CONSTRUCTION

Please order in package quantity.



These drills are made with a heavy web construction and may be used with heavier feeds in harder materials. Because of torsional strength and a 135° split point, this drill is popular in hand held drilling applications to reduce breakage and eliminate skidding or walking.

FRACTIONAL SIZES

Size	Dec. Equiv.	Flute Length	Overall Length	Pkg. Qty.	Price Each	Size	Dec. Equiv.	Flute Length	Overall Length	Pkg. Qty.	Price Each	Size	Dec. Equiv.	Flute Length	Overall Length	Pkg. Qty.	Price Each
3/64	.0469	3/4	1-3/4	12	1.15	13/64	.2031	2-7/16	3-5/8	12	1.96	23/64	.3594	3-1/2	4-7/8	6	5.08
1/16	.0625	7/8	1-7/8	12	1.25	7/32	.2188	2-1/2	3-3/4	12	2.13	3/8	.3750	3-5/8	5	6	5.36
5/64	.0781	1	2	12	1.25	15/64	.2344	2-5/8	3-7/8	12	2.29	25/64	.3906	3-3/4	5-1/8	6	6.00
3/32	.0938	1-1/4	2-1/4	12	1.25	1/4	.2500	2-3/4	4	12	2.32	13/32	.4062	3-7/8	5-1/4	6	6.25
7/64	.1094	1-1/2	2-5/8	12	1.31	17/64	.2656	2-7/8	4-1/8	12	2.96	27/64	.4219	3-15/16	5-3/8	6	6.96
1/8	.1250	1-5/8	2-3/4	12	1.32	9/32	.2812	2-15/16	4-1/4	6	3.21	7/16	.4375	4-1/16	5-1/2	6	7.21
9/64	.1406	1-3/4	2-7/8	12	1.39	19/64	.2969	3-1/16	4-3/8	6	3.54	29/64	.4531	4-3/16	5-5/8	6	8.08
5/32	.1562	2	3-1/8	12	1.42	5/16	.3125	3-3/16	4-1/2	6	3.72	15/32	.4688	4-5/16	5-3/4	6	8.54
11/64	.1719	2-1/8	3-1/4	12	1.47	21/64	.3281	3-5/16	4-5/8	6	4.10	31/64	.4844	4-3/8	5-7/8	6	9.04
3/16	.1875	2-5/16	3-1/2	12	1.73	11/32	.3438	3-7/16	4-3/4	6	4.61	1/2	.5000	4-1/2	6	6	9.15

MAINTENANCE **COBALT** JOBBER LENGTH DRILL

SET NO. X307CX

115 Piece Cobalt Combination Jobber Drill Set
1/16 - 1/2 by 64ths, A - Z,
No. 1 - 60 in Metal Index
SET PRICE — \$449.00

SET NO. X307CW

60 Piece Cobalt Jobber Drill Set
No. 1 - 60 in Metal Index
SET PRICE — \$129.00

SET NO. X307CL

26 Piece Cobalt Jobber Drill Set
A - Z in Metal Index
SET PRICE — \$199.00

HEAVY DUTY — 135° SPLIT POINT

► LIST NO. X300C — SUPER COBALT

Please order in package quantity.



Cobalt drills display higher red hardness and are especially effective in drilling hard or abrasive materials.

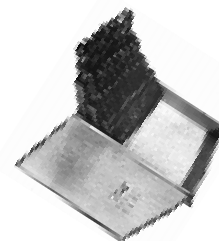

SET NO. X307CF

29 Piece Cobalt Fractional Jobber Drill Set
1/16 - 1/2 x 64ths in Metal Index
SET PRICE — \$159.00

FRACTIONAL SIZES

Size	Dec. Equiv.	Flute Length	Overall Length	Pkg. Qty.	Price Each	Size	Dec. Equiv.	Flute Length	Overall Length	Pkg. Qty.	Price Each	Size	Dec. Equiv.	Flute Length	Overall Length	Pkg. Qty.	Price Each
3/64	.0469	3/4	1-3/4	12	1.82	13/64	.2031	2-7/16	3-5/8	12	3.42	23/64	.3594	3-1/2	4-7/8	6	9.44
1/16	.0625	7/8	1-7/8	12	1.76	7/32	.2188	2-1/2	3-3/4	12	3.72	3/8	.3750	3-5/8	5	6	9.26
5/64	.0781	1	2	12	1.73	15/64	.2344	2-5/8	3-7/8	12	3.99	25/64	.3906	3-3/4	5-1/8	6	10.37
3/32	.0938	1-1/4	2-1/4	12	1.73	1/4	.2500	2-3/4	4	12	4.15	13/32	.4062	3-7/8	5-1/4	6	10.91
7/64	.1094	1-1/2	2-5/8	12	1.82	17/64	.2656	2-7/8	4-1/8	12	4.99	27/64	.4219	3-15/16	5-3/8	6	11.99
1/8	.1250	1-5/8	2-3/4	12	2.10	9/32	.2812	2-15/16	4-1/4	6	5.19	7/16	.4375	4-1/16	5-1/2	6	12.27
9/64	.1406	1-3/4	2-7/8	12	2.16	19/64	.2969	3-1/16	4-3/8	6	6.16	29/64	.4531	4-3/16	5-5/8	6	14.89
5/32	.1562	2	3-1/8	12	2.47	5/16	.3125	3-3/16	4-1/2	6	6.64	15/32	.4688	4-5/16	5-3/4	6	15.06
11/64	.1719	2-1/8	3-1/4	12	2.63	21/64	.3281	3-5/16	4-5/8	6	7.38	31/64	.4844	4-3/8	5-7/8	6	16.41
3/16	.1875	2-5/16	3-1/2	12	2.98	11/32	.3438	3-7/16	4-3/4	6	7.93	1/2	.5000	4-1/2	6	6	15.57

• SELF STARTING STEP DRILL



The self starting step drill has an exclusive single radial concave flute, that allows drilling of round holes in thin materials. For use in drilling copper, brass, aluminum and thin steels.

Size Range	Step Increments	No. of Hole Sizes	Shank Size	H.S. Tool No.	H.S. Price Each	TiN Coated Tool No.	TiN Price Each
1/8-1/2	32 ^{nds}	13	1/4	SSD1	16.50	SSD1T	22.00
3/16-1/2	16 th	6	1/4	SSD2	16.50	SSD2T	22.00
1/4-3/4	16 th	9	3/8	SSD3	29.90	SSD3T	39.75
3/16-7/8	16 th	12	3/8	SSD4	35.00	SSD4T	47.50
1/4-1-3/8	8 th	10	1/2	SSD5	62.75	SSD5T	83.75

SETS

SET NO. SSDS
3 PIECE H.S. SET
 Contains 1 Piece of Each:
 SSD1, SSD2, SSD3
 Supplied in wood block
SET PRICE - \$63.00

SET NO. SSDST
3 PIECE TiN COATED SET
 Contains 1 Piece of Each:
 SSD1T, SSD2T, SSD3T
 Supplied in wood block
SET PRICE - \$84.00

SPECIAL STEP DRILL QUOTATION FORM

REQUESTING A QUOTE FOR SPECIAL STEP DRILLS IS AS EASY AS 1, 2, 3

1. Make a copy of this form.
2. Fill in the specifications.
3. Fax or email to your Michigan Drill Distributor.

Additional order forms may be down loaded from our website under technical data special step drills.

When ordering Special Step drills, please specify the following:

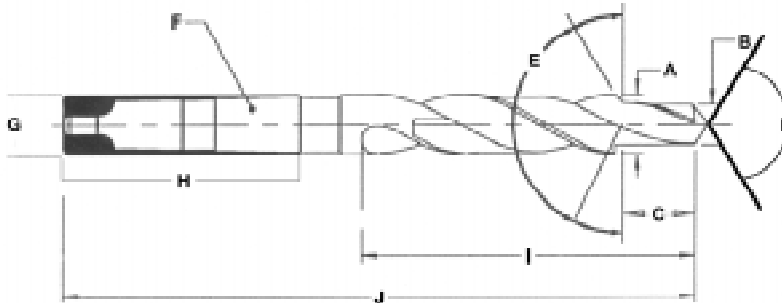

- | | |
|--|---|
| A. _____ Major diameter | I. _____ Flute length |
| B. _____ Minor diameter (+000 -.002), unless otherwise specified | J. _____ Overall Length |
| C. _____ Step length (+/- .015), unless otherwise specified | Finish: Bright _____ Oxide _____ Coated _____ (specify) |
| D. _____ Point angle | Helix: Standard _____ Fast _____ Slow _____ or specify _____ |
| E. _____ Included angle | Tool Material: High Speed _____ Cobalt _____ Other _____ |
| F. _____ If taper shank advise Morse taper number | _____ Quantity required |
| G. _____ Shank diameter (if different than A), or standard tang | Right hand unless specified _____ Left Hand |
| H. _____ Length of shank if reduced | |

STANDARD STEP DRILLS

JOBBER LENGTH — TAPER LENGTH



Only **MICHIGAN DRILL** makes these tools as a standard. **OFF-THE-SHELF** for **IMMEDIATE DELIVERY!**
 An essential tool for every tool room. One tool does two jobs in a single pass. They can be sharpened repeatedly and are easily modified for any special length-of-step.

Special Step Drills available. Please inquire.

For Drilling and Counterboring **Cap Screw Clearance Holes**

- LIST NO. 371 — JOBBER LENGTH
- LIST NO. 471 — TAPER LENGTH



Screw Size	Minor Diameter	Major Diameter	Step Length	Jobber Length List No. 371			Taper Length List No. 471		
				Flute Length	Overall Length	Price Each	Flute Length	Overall Length	Price Each
No. 4	.1360	7/32	3/8	2-1/2	3-3/4	11.65	—	—	—
No. 5	.141	.228	3/8	2-5/8	3-7/8	12.25	—	—	—
No. 6	.150	1/4	1/2	2-3/4	4	12.97	3-3/4	6-1/8	18.15
No. 8	.178	"L"	1/2	2-15/16	4-1/4	14.85	4	6-3/8	26.65
No. 10	.204	"Q"	5/8	3-7/16	4-3/4	16.25	4-1/8	6-1/2	27.50
1/4	9/32	13/32	11/16	3-7/8	5-1/4	18.75	4-3/8	7	30.50
5/16	11/32	1/2	3/4	4-1/2	6	24.90	4-3/4	7-3/4	34.50
3/8	13/32	19/32	7/8	5-3/16	7-1/8	39.80	4-7/8	8-3/4	48.35
7/16	15/32	11/16	1	5-5/8	7-5/8	47.50	—	—	—
1/2	17/32	25/32	1	3-1/4	5-1/8*	65.50	6	9-7/8	72.20
5/8	21/32	31/32	1	3-7/8	5-7/8*	87.50	6-3/8	11	96.80

SETS

CAP SCREW SETS
 No. 6 thru 3/8 NC Screw Sizes
 (6 tools in wood block)

JOBBER LENGTH SET NO. 371S — \$127.52

TAPER LENGTH SET NO. 471S — \$185.65

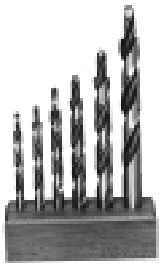
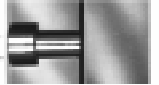

*Shorter than Jobber Length.

For Drilling and Countersinking **82° Flat Head Machine Screw Clearance Holes**

- LIST NO. 372 — JOBBER LENGTH



Screw Size	Minor Diameter	Major Diameter	Step Length	Jobber Length List No. 372		
				Flute Length	Overall Length	Price Each
No. 4	.116	15/64	3/8	2-5/8	3-7/8	13.10
No. 5	.128	"F"	3/8	2-7/8	4-1/8	13.70
No. 6	.142	9/32	1/2	2-15/16	4-1/4	14.35
No. 8	.169	"Q"	1/2	3-7/16	4-3/4	16.95
No. 10	.196	"W"	5/8	3-3/4	5-1/8	18.50
1/4	.257	1/2	11/16	4-1/2	6	22.90
5/16	.320	5/8	3/4	5-3/16	7-1/8	35.90
3/8	.383	3/4	7/8	3-1/8	5*	49.75
7/16	.446	13/16	1	3-3/8	5-1/4*	64.80
1/2	.510	7/8	1	3-1/2	5-1/2*	71.50

SET

FLAT HEAD SCREW SET
 No. 6 thru 3/8 Screw Sizes
 (6 tools in wood block)

JOBBER LENGTH SET NO. 372S — \$158.35

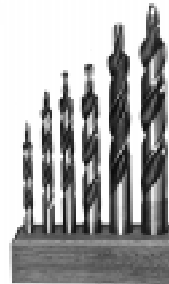

*Shorter than Jobber Length.

For Drilling **45° Chamfered Holes To-Be-Tapped** (To produce approx. 70% thread)

- LIST NO. 370 — JOBBER LENGTH
- LIST NO. 470 — TAPER LENGTH



Screw Size	Minor Diameter	Major Diameter	Step Length	Jobber Length List No. 370			Taper Length List No. 470		
				Flute Length	Overall Length	Price Each	Flute Length	Overall Length	Price Each
4-40	.089	.1285	3/8	1-5/8	2-3/4	11.50	3	5-3/8	17.25
5-40	.101	9/64	1/2	1-3/4	2-7/8	12.10	3	5-3/8	18.10
6-32	.109	5/32	1/2	2	3-1/8	12.25	3	5-3/8	18.50
8-32	.136	3/16	1/2	2-5/16	3-1/2	12.56	3-3/8	5-3/4	18.65
8-36	.136	3/16	1/2	2-5/16	3-1/2	12.75	3-3/8	5-3/4	19.00
10-24	.152	1/4	5/8	2-3/4	4	13.35	3-3/4	6-1/8	20.95
10-32	.161	1/4	5/8	2-3/4	4	13.35	3-3/4	6-1/8	20.95
12-24	.179	9/32	11/16	2-15/16	4-1/4	15.50	—	—	—
1/4-20	.204	21/64	13/16	3-5/16	4-5/8	16.45	4-1/8	6-1/2	23.73
1/4-28	.218	21/64	13/16	3-5/16	4-5/8	16.75	4-1/8	6-1/2	24.25
5/16-18	.261	13/32	15/16	3-7/8	5-1/4	18.75	4-3/8	7	26.60
5/16-24	.272	13/32	15/16	3-7/8	5-1/4	19.00	4-3/8	7	27.25
3/8-16	.316	31/64	1	4-3/8	5-7/8	24.80	4-3/4	7-3/4	38.50
3/8-24	.339	31/64	1	4-3/8	5-7/8	25.25	4-3/4	7-3/4	38.50
7/16-14	.375	17/32	1-1/16	4-13/16	6-5/8	43.23	4-3/4	8	47.30
7/16-20	.390	17/32	1-1/16	4-13/16	6-5/8	43.23	4-3/4	8	47.30
1/2-13	.437	5/8	1-1/16	5-3/16	7-1/8	49.90	4-7/8	8-3/4	57.50
1/2-20	.452	5/8	1-1/16	5-3/16	7-1/8	50.50	4-7/8	8-3/4	57.50
5/8-11	.531	3/4	1-1/16	5-5/8	7-5/8	62.90	—	—	—

SETS

TAP DRILL SETS
 No. 6 thru 3/8 NC Tap Sizes
 (6 tools in wood block)
 Contains 1 piece of each:
 6-32, 8-32, 10-24, 1/4-20, 5/16-18, 3/8-16

JOBBER LENGTH SET NO. 370S — \$98.16

TAPER LENGTH SET NO. 470S — \$146.93

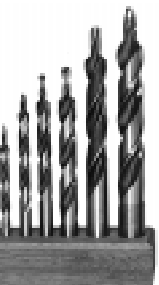
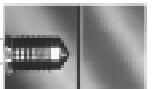



STANDARD *Cobalt* STEP DRILLS

JOBBER LENGTH

An essential tool for every tool room. One tool does two jobs in a single pass. They can be sharpened repeatedly and are easily modified for any special length-of-step.

Special step drills also available. Please Inquire.

For Drilling and Counterboring **Cap Screw Clearance Holes**



LIST NO. 371C

Screw Size	Minor Diameter	Major Diameter	Step Length	Flute Length	Overall Length	Price Each
No. 6	.150	1/4	1/2	2-3/4	4	23.35
No. 8	.178	"L"	1/2	2-15/16	4-1/4	26.73
No. 10	.204	"Q"	5/8	3-7/16	4-3/4	29.25
1/4	9/32	13/32	11/16	3-7/8	5-1/4	33.75
5/16	11/32	1/2	3/4	4-1/2	6	44.82
3/8	13/32	19/32	7/8	5-3/16	7-1/8	71.64
7/16	15/32	11/16	1	5-5/8	7-5/8	85.50
1/2	17/32	25/32	1	3-1/4	5-1/8*	117.90

*Shorter than Jobber Length.

SET

CAP SCREW SET

No. 6 thru 3/8 Screw Sizes
(6 tools in wood block)

SET NO. 371CS — \$230.00

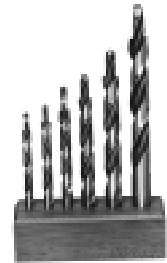

For Drilling and Countersinking **82° Flat Head Machine Screw Clearance Holes**



LIST NO. 372C

Screw Size	Minor Diameter	Major Diameter	Step Length	Flute Length	Overall Length	Price Each
No. 6	.142	9/32	1/2	2-15/16	4-1/4	25.83
No. 8	.169	"Q"	1/2	3-7/16	4-3/4	30.51
No. 10	.196	"W"	5/8	3-3/4	5-1/8	33.30
1/4	.257	1/2	11/16	4-1/2	6	41.22
5/16	.320	5/8	3/4	5-3/16	7-1/8	64.62
3/8	.383	3/4	7/8	3-1/8	5*	89.55
7/16	.446	13/16	1	3-3/8	5-1/4*	116.64
1/2	.510	7/8	1	3-1/2	5-1/2*	128.70

*Shorter than Jobber Length.

SET

FLAT HEAD SET

No. 6 thru 3/8 Screw Sizes
(6 tools in wood block)

SET NO. 372CS — \$285.00

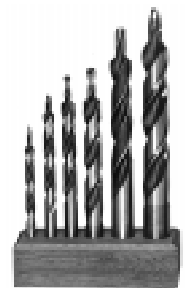

For Drilling **45° Chamfered Holes To-Be-Tapped** (To produce approx. 70% thread)



LIST NO. 370C

Screw Size	Minor Diameter	Major Diameter	Step Length	Flute Length	Overall Length	Price Each
6-32	.1096	5/32	1/2	2	3-1/8	22.05
8-32	.1356	3/16	1/2	2-5/16	3-1/2	22.61
10-24	.1521	1/4	5/8	2-3/4	4	24.03
10-32	.1616	1/4	5/8	2-3/4	4	24.03
12-24	.1781	9/32	11/16	2-15/16	4-1/4	27.90
1/4-20	.2045	21/64	13/16	3-5/16	4-5/8	29.61
5/16-18	.2619	13/32	15/16	3-7/8	5-1/4	33.75
3/8-16	.3181	31/64	1	4-3/8	5-7/8	44.64

SET

TAP DRILL SET

No. 6 thru 3/8 NC Tap Sizes
Contains 1 piece of each:
6-32, 8-32, 10-24, 1/4-20, 5/16-18, 3/8-16

SET NO. 370CS — \$228.00

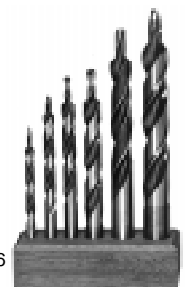

STANDARD METRIC STEP DRILLS

JOBBER LENGTH



An essential tool for every tool room. One tool does two jobs in a single pass. They can be sharpened repeatedly and are easily modified for any special length-of-step.

Special step drills also available. Please inquire.

For Drilling and Counterboring Cap Screw Clearance Holes

■ LIST NO. 371M



Screw Size mm	Minor Diameter	Major Diameter	Step Length	Flute Length	Overall Length	Price Each
3.00	.146	1/4	3/8	2-3/4	4	13.95
4.00	.189	5/16	1/2	3-3/16	4-1/2	17.89
5.00	.228	3/8	5/8	3-5/8	5	20.25
6.00	.268	7/16	5/8	4-1/16	5-1/2	22.25
8.00	.346	9/16	3/4	4-13/16	6-5/8	28.25
10.00	.425	11/16	7/8	5-5/8	7-5/8	43.35
12.00	.504	3/4	1	5-5/8	7-5/8	52.39
14.00	.581	7/8	1	3-1/2	5-1/2*	70.91
16.00	.659	1	1	4	6*	97.25

*Screw machine drill length.

SET

CAP SCREW SET

3mm thru 10mm Screw Sizes
(6 tools in wood block)

JOBBER LENGTH

SET NO. 371MS — \$145.00

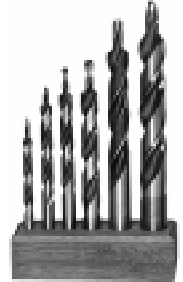

For Drilling 45° Chamfered Holes To-Be-Tapped (To produce approx. 70% thread)

■ LIST NO. 370M



Screw Size mm	Minor Diameter	Major Diameter	Step Length	Flute Length	Overall Length	Price Each
3x0.50	.098	5/32	1/2	2	3-1/8	12.95
4x0.70	.130	13/64	1/2	2-7/16	3-5/8	13.95
5x0.80	.165	1/4	5/8	2-3/4	4	14.29
6x1.00	.197	19/64	11/16	3-1/16	4-3/8	16.49
8x1.25	.266	13/32	15/16	3-7/8	5-1/4	19.95
10x1.50	.335	1/2	1	4-1/2	6	26.51
12x1.75	.406	19/32	1-1/16	5-3/16	7-1/8	52.51
14x2.00	.472	11/16	1-1/16	5-5/8	7-5/8	59.95
16x2.00	.551	3/4	1-1/16	5-5/8	7-5/8	66.95

SET

TAP DRILL SET

3mm thru 10mm Tap Sizes
(6 tools in wood block)

JOBBER LENGTH

SET NO. 370MS — \$104.00

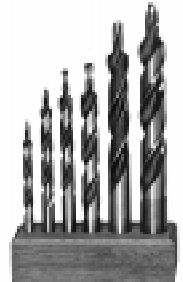

STANDARD SUBLAND STEP DRILLS

JOBBER LENGTH — 180° Step Angle, 118° point

■ LIST NO. 374



The Michigan Drill Subland series is an addition to our OFF-THE-SHELF standard step drill program. The Subland Step Drill will enable you to do multi-diameter drilling to specified hole tolerances in a one step operation. Coupled with the double land construction these tools will re-sharpen without extensive undercut rework, lowering your overall production costs.

For drilling and counterboring cap screw clearance holes.

Screw Size	Minor Diameter	Major Diameter	Step Length	Flute Length	Overall Length	Price Each
No. 6	.1405	.2280	5/16	2-5/8	3-7/8	26.59
No. 8	.1750	.2812	3/8	2-15/16	4-1/4	27.15
No.10	.2055	.3437	1/2	3-7/16	4-3/4	29.12
1/4	.2812	.4062	1/2	3-7/8	5-1/4	32.62
5/16	.3437	.5000	5/8	4-1/16	5-1/2	38.66
3/8	.4062	.5937	3/4	5-3/16	7-1/8	50.16

Other subland drills available from stock.



HIGH SPEED STEEL

JOBBER LENGTH DRILLS

AUTOMOTIVE SERIES — TANGED

► LIST NO. 350 — OXIDE FINISH, 118° POINT

Please order in package quantity.

For use in split sleeve drill drivers.



We feature the only complete range of tanged Jobber Drills **OFF-THE-SHELF** for **IMMEDIATE DELIVERY!**

Through our modification shop, we can also tang any other style of straight shank drill at a moderate cost.

FRACTIONAL SIZES

Size	Dec. Equiv.	Flute Length	Overall Length	Pkg. Qty.	Price Each
1/8	.1250	1-5/8	2-3/4	12	1.97
9/64	.1406	1-3/4	2-7/8	12	2.10
5/32	.1562	2	3-1/8	12	2.32
11/64	.1719	2-1/8	3-1/4	12	2.67
3/16	.1875	2-5/16	3-1/2	12	2.96
13/64	.2031	2-7/16	3-5/8	12	3.34
7/32	.2188	2-1/2	3-3/4	12	3.69
15/64	.2344	2-5/8	3-7/8	12	4.10
1/4	.2500	2-3/4	4	12	4.20
17/64	.2656	2-7/8	4-1/8	12	5.11
9/32	.2812	2-15/16	4-1/4	6	5.56
19/64	.2969	3-1/16	4-3/8	6	6.08
5/16	.3125	3-3/16	4-1/2	6	6.44

Size	Dec. Equiv.	Flute Length	Overall Length	Pkg. Qty.	Price Each
21/64	.3281	3-5/16	4-5/8	6	7.30
11/32	.3438	3-7/16	4-3/4	6	7.42
23/64	.3594	3-1/2	4-7/8	6	8.64
3/8	.3750	3-5/8	5	6	8.85
25/64	.3906	3-3/4	5-1/8	6	9.97
13/32	.4062	3-7/8	5-1/4	6	10.04
27/64	.4219	3-15/16	5-3/8	6	11.71
7/16	.4375	4-1/16	5-1/2	6	11.78
29/64	.4531	4-3/16	5-5/8	6	14.09
15/32	.4688	4-5/16	5-3/4	6	14.43
31/64	.4844	4-3/8	5-7/8	6	15.67
1/2	.5000	4-1/2	6	6	15.13
33/64	.5156	4-13/16	6-5/8	1	27.01

Size	Dec. Equiv.	Flute Length	Overall Length	Pkg. Qty.	Price Each
17/32	.5312	4-13/16	6-5/8	1	28.50
35/64	.5469	4-13/16	6-5/8	1	31.10
9/16	.5625	4-13/16	6-5/8	1	31.84
37/64	.5781	4-13/16	6-5/8	1	33.42
19/32	.5938	5-3/16	7-1/8	1	33.22
39/64	.6094	5-3/16	7-1/8	1	36.34
5/8	.6250	5-3/16	7-1/8	1	36.00
41/64	.6406	5-3/16	7-1/8	1	38.35
21/32	.6562	5-3/16	7-1/8	1	38.00
43/64	.6719	5-5/8	7-5/8	1	44.22
11/16	.6875	5-5/8	7-5/8	1	43.75

LETTER SIZES

Size	Dec. Equiv.	Flute Length	Overall Length	Pkg. Qty.	Price Each
A	.2340	2-5/8	3-7/8	12	4.75
B	.2380	2-3/4	4	12	4.75
C	.2420	2-3/4	4	12	4.75
D	.2460	2-3/4	4	12	4.75
E	.2500	2-3/4	4	12	4.20
F	.2570	2-7/8	4-1/8	12	5.10
G	.2610	2-7/8	4-1/8	12	5.80
H	.2660	2-7/8	4-1/8	12	5.80
I	.2720	2-7/8	4-1/8	6	5.80

Size	Dec. Equiv.	Flute Length	Overall Length	Pkg. Qty.	Price Each
J	.2770	2-7/8	4-1/8	6	6.00
K	.2810	2-15/16	4-1/4	6	6.00
L	.2900	2-15/16	4-1/4	6	7.30
M	.2950	3-1/16	4-3/8	6	7.30
N	.3020	3-1/16	4-3/8	6	7.30
O	.3160	3-3/16	4-1/2	6	7.30
P	.3230	3-5/16	4-5/8	6	7.75
Q	.3320	3-7/16	4-3/4	6	7.75
R	.3390	3-7/16	4-3/4	6	7.75

Size	Dec. Equiv.	Flute Length	Overall Length	Pkg. Qty.	Price Each
S	.3480	3-1/2	4-7/8	6	9.35
T	.3580	3-1/2	4-7/8	6	10.20
U	.3680	3-5/8	5	6	10.20
V	.3770	3-5/8	5	6	10.95
W	.3860	3-3/4	5-1/8	6	10.95
X	.3970	3-3/4	5-1/8	6	13.25
Y	.4040	3-7/8	5-1/4	6	13.25
Z	.4130	3-7/8	5-1/4	6	14.50

WIRE GAUGE SIZES

Size	Dec. Equiv.	Flute Length	Overall Length	Pkg. Qty.	Price Each
1	.2280	2-5/8	3-7/8	12	4.25
2	.2210	2-5/8	3-7/8	12	4.25
3	.2130	2-1/2	3-3/4	12	3.80
4	.2090	2-1/2	3-3/4	12	3.80
5	.2055	2-1/2	3-3/4	12	3.80
6	.2040	2-1/2	3-3/4	12	3.80
7	.2010	2-7/16	3-5/8	12	3.40
8	.1990	2-7/16	3-5/8	12	3.40
9	.1960	2-7/16	3-5/8	12	3.40
10	.1935	2-7/16	3-5/8	12	3.40
11	.1910	2-5/16	3-1/2	12	3.20
12	.1890	2-5/16	3-1/2	12	3.20

Size	Dec. Equiv.	Flute Length	Overall Length	Pkg. Qty.	Price Each
13	.1850	2-5/16	3-1/2	12	3.20
14	.1820	2-3/16	3-3/8	12	3.20
15	.1800	2-3/16	3-3/8	12	3.20
16	.1770	2-3/16	3-3/8	12	3.20
17	.1730	2-3/16	3-3/8	12	3.20
18	.1695	2-1/8	3-1/4	12	2.77
19	.1660	2-1/8	3-1/4	12	2.77
20	.1610	2-1/8	3-1/4	12	2.77
21	.1590	2-1/8	3-1/4	12	2.77
22	.1570	2	3-1/8	12	2.77
23	.1540	2	3-1/8	12	2.77
24	.1520	2	3-1/8	12	2.53

Size	Dec. Equiv.	Flute Length	Overall Length	Pkg. Qty.	Price Each
25	.1495	1-7/8	3	12	2.53
26	.1470	1-7/8	3	12	2.40
27	.1440	1-7/8	3	12	2.40
28	.1405	1-3/4	2-7/8	12	2.16
29	.1360	1-3/4	2-7/8	12	2.10
30	.1285	1-5/8	2-3/4	12	1.98
32	.1160	1-5/8	2-3/4	12	1.98
37	.1040	1-7/16	2-1/2	12	1.98
43	.0890	1-1/4	2-1/4	12	1.98
46	.0810	1-1/8	2-1/8	12	1.98
48	.0760	1	2	12	1.98
50	.0700	1	2	12	1.98

METRIC SIZES

Size	Dec. Equiv.	Flute Length	Overall Length	Pkg. Qty.	Price Each
3.20	.1260	1-5/8	2-3/4	12	2.00
3.30	.1299	1-3/4	2-7/8	12	2.00
3.40	.1339	1-3/4	2-7/8	12	2.00
3.50	.1378	1-3/4	2-7/8	12	2.00
3.90	.1535	2	3-1/8	12	2.50
5.70	.2244	2-5/8	3-7/8	12	4.30
6.10	.2402	2-3/4	4	12	4.70

Size	Dec. Equiv.	Flute Length	Overall Length	Pkg. Qty.	Price Each
6.40	.2520	2-7/8	4-1/8	12	5.00
7.25	.2854	2-15/16	4-1/4	12	6.65
7.40	.2913	3-1/16	4-3/8	12	6.99
9.00	.3543	3-1/2	4-7/8	6	11.20
11.00	.4331	4-1/16	5-1/2	6	12.50
12.00	.4724	4-3/8	5-7/8	6	16.50
19.00	.7480	5-5/8	7-5/8	1	56.50



TAPER LENGTH DRILLS

- ▶ LIST NO. 400 — HIGH SPEED STEEL, GENERAL PURPOSE, 118° POINT
- LIST NO. 410C* — SUPER COBALT, HEAVY DUTY, 135° SPLIT POINT

Please order in package quantity.

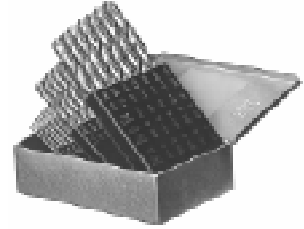
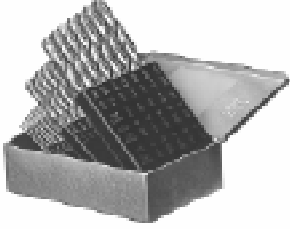

Taper length drills are designed for general purpose drilling where long length is required.

Used in production drilling, they have the same flute length as Taper Shank drills.

SET NO. 407F

29 Piece High Speed Surface Treated Set
1/16 - 1/2 x 64ths in Metal Index
SET PRICE — \$327.00

SET NO. 407CF

29 Piece Cobalt Fractional Set
1/16 - 1/2 x 64ths in Metal Index
SET PRICE — \$672.00

FRACTIONAL SIZES

Size	Dec. Equiv.	Flute Length	Overall Length	Pkg. Qty.	Price Each	
					H.S. List No. 400	Cobalt List No. 410C*
1/64	.0156	5/16	1-1/2	12	9.48	17.38
1/32	.0312	3/4	2	12	6.92	12.50
3/64	.0469	1-1/8	2-1/4	12	3.26	7.25
1/16	.0625	1-3/4	3	12	3.39	6.93
5/64	.0781	2	3-3/4	12	3.98	8.08
3/32	.0938	2-1/4	4-1/4	12	4.75	9.48
7/64	.1094	2-1/2	4-5/8	12	6.01	12.17
1/8	.1250	2-3/4	5-1/8	12	6.11	12.03
9/64	.1406	3	5-3/8	12	7.41	14.77
5/32	.1562	3	5-3/8	12	7.41	14.92
11/64	.1719	3-3/8	5-3/4	12	7.47	14.92
3/16	.1875	3-3/8	5-3/4	12	7.41	14.63
13/64	.2031	3-5/8	6	12	8.73	17.42
7/32	.2188	3-5/8	6	12	8.65	17.10
15/64	.2344	3-3/4	6-1/8	12	8.73	18.06
1/4	.2500	3-3/4	6-1/8	12	8.65	17.09
17/64	.2656	3-7/8	6-1/4	12	10.67	22.31
9/32	.2812	3-7/8	6-1/4	6	10.57	21.11
19/64	.2969	4	6-3/8	6	10.82	22.31
5/16	.3125	4	6-3/8	6	10.71	21.11
21/64	.3281	4-1/8	6-1/2	6	12.39	25.67
11/32	.3438	4-1/8	6-1/2	6	12.28	24.74
23/64	.3594	4-1/4	6-3/4	6	14.58	30.25
3/8	.3750	4-1/4	6-3/4	6	14.44	28.07
25/64	.3906	4-3/8	7	6	15.22	31.44
13/32	.4062	4-3/8	7	6	15.08	30.32
27/64	.4219	4-5/8	7-1/4	6	16.43	34.11
7/16	.4375	4-5/8	7-1/4	6	16.59	32.93
29/64	.4531	4-3/4	7-1/2	6	18.58	38.65
15/32	.4688	4-3/4	7-1/2	6	19.54	39.35
31/64	.4844	4-3/4	7-3/4	6	20.59	42.77
1/2	.5000	4-3/4	7-3/4	6	20.38	40.48
33/64	.5156	4-3/4	8	1	29.17	55.45
17/32	.5312	4-3/4	8	1	28.88	53.47
35/64	.5469	4-7/8	8-1/4	1	30.66	59.92
9/16	.5625	4-7/8	8-1/4	1	30.37	57.77
37/64	.5781	4-7/8	8-3/4	1	35.84	69.95
19/32	.5938	4-7/8	8-3/4	1	35.84	67.44
39/64	.6094	4-7/8	8-3/4	1	37.09	69.95
5/8	.6250	4-7/8	8-3/4	1	36.73	67.44
41/64	.6406	5-1/8	9	1	44.70	78.58
21/32	.6562	5-1/8	9	1	42.67	74.40
43/64	.6719	5-3/8	9-1/4	1	52.50	90.24
11/16	.6875	5-3/8	9-1/4	1	50.77	87.04
45/64	.7031	5-5/8	9-1/2	1	55.28	98.78
23/32	.7188	5-5/8	9-1/2	1	52.77	95.23
47/64	.7344	5-7/8	9-3/4	1	59.45	104.53
3/4	.7500	5-7/8	9-3/4	1	55.67	100.81

Size	Dec. Equiv.	Flute Length	Overall Length	Pkg. Qty.	Price Each	
					H.S. List No. 400	Cobalt List No. 410C*
49/64	.7656	6	9-7/8	1	65.28	123.08
25/32	.7812	6	9-7/8	1	62.33	118.69
51/64	.7969	6-1/8	10	1	70.21	134.75
13/16	.8125	6-1/8	10	1	66.39	127.57
53/64	.8281	6-1/8	10	1	75.96	136.93
27/32	.8438	6-1/8	10	1	70.55	132.04
55/64	.8594	6-1/8	10	1	79.78	143.87
7/8	.8750	6-1/8	10	1	74.12	138.74
57/64	.8906	6-1/8	10	1	83.13	152.65
29/32	.9062	6-1/8	10	1	77.21	144.54
59/64	.9219	6-1/8	10-3/4	1	90.46	166.09
15/16	.9375	6-1/8	10-3/4	1	84.01	157.26
61/64	.9531	6-3/8	11	1	99.79	183.34
31/32	.9688	6-3/8	11	1	92.68	173.59
63/64	.9844	6-3/8	11	1	104.03	187.63
1	1.0000	6-3/8	11	1	96.61	180.93
1-1/64	1.0156	6-1/2	11-1/8	1	137.11	—
1-1/32	1.0312	6-1/2	11-1/8	1	121.19	—
1-3/64	1.0469	6-5/8	11-1/4	1	141.80	—
1-1/16	1.0625	6-5/8	11-1/4	1	125.33	—
1-5/64	1.0781	6-7/8	11-1/2	1	152.13	—
1-3/32	1.0938	6-7/8	11-1/2	1	134.45	—
1-7/64	1.1094	7-1/8	11-3/4	1	157.89	—
1-1/8	1.1250	7-1/8	11-3/4	1	133.21	—
1-9/64	1.1406	7-1/4	11-7/8	1	158.92	—
1-5/32	1.1562	7-1/4	11-7/8	1	151.89	—
1-11/64	1.1719	7-3/8	12	1	171.11	—
1-3/16	1.1875	7-3/8	12	1	156.10	—
1-13/64	1.2031	7-1/2	12-1/8	1	176.22	—
1-7/32	1.2188	7-1/2	12-1/8	1	160.75	—
1-15/64	1.2344	7-7/8	12-1/2	1	183.28	—
1-1/4	1.2500	7-7/8	12-1/2	1	167.22	—
1-9/32	1.2656	8-1/2	14-1/8	1	194.10	—
1-5/16	1.3125	8-5/8	14-1/4	1	209.00	—
1-11/32	1.3438	8-3/4	14-3/8	1	215.00	—
1-3/8	1.3750	8-7/8	14-1/2	1	224.17	—
1-13/32	1.4062	9	14-5/8	1	234.10	—
1-7/16	1.4375	9-1/8	14-3/4	1	244.27	—
1-15/32	1.4688	9-1/4	14-7/8	1	254.40	—
1-1/2	1.5000	9-3/8	15	1	273.83	—
1-9/16	1.5625	9-5/8	15-1/4	1	306.41	—
1-5/8	1.6250	9-7/8	15-5/8	1	345.97	—
1-11/16	1.6875	10-1/8	16	1	399.66	—
1-3/4	1.7500	10-1/2	16-1/4	1	416.90	—
1-13/16	1.8125	10-1/2	16-1/4	1	497.35	—
1-7/8	1.8750	10-5/8	16-1/4	1	545.00	—
1-15/16	1.9375	10-3/4	16-5/8	1	563.00	—
2	2.0000	10-3/4	17-1/4	1	574.00	—

* Cobalt sizes over 1/2" furnished with notched point.

TAPER LENGTH DRILLS



- ▶ LIST NO. 400 — HIGH SPEED STEEL, GENERAL PURPOSE, 118° POINT
 - LIST NO. 410C* — SUPER COBALT, HEAVY DUTY, 135° SPLIT POINT
- Please order in package quantity.*

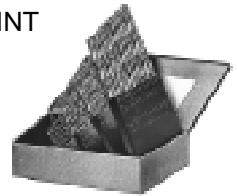

SET NO. 407L
26 Piece High Speed
Taper Length
A - Z Set with Metal Index
SET PRICE — \$420.00

Taper length drills are used where a longer overall length and flute length are required. High speed drills are good for general purpose application and cobalt drills are good for stainless and other tough alloy steels, castings, and forgings.

SET NO. 407W
60 Piece High Speed
Taper Length
No. 1-60 Set with Metal Index
SET PRICE — \$512.00

WIRE GAUGE SIZES

Size	Dec. Equiv.	Flute Length	Overall Length	Pkg. Qty.	Price Each	
					H.S. List No. 400	Cobalt List No. 410C
1	.2280	3-3/4	6-1/8	12	11.79	19.58
2	.2210	3-3/4	6-1/8	12	11.79	19.58
3	.2130	3-5/8	6	12	11.43	19.58
4	.2090	3-5/8	6	12	11.43	19.58
5	.2055	3-5/8	6	12	11.43	19.58
6	.2040	3-5/8	6	12	11.43	19.58
7	.2010	3-5/8	6	12	11.43	19.58
8	.1990	3-5/8	6	12	11.43	19.58
9	.1960	3-5/8	6	12	11.43	19.58
10	.1935	3-5/8	6	12	11.43	19.58
11	.1910	3-5/8	6	12	11.43	19.58
12	.1890	3-5/8	6	12	11.43	19.58
13	.1850	3-3/8	5-3/4	12	10.35	17.88
14	.1820	3-3/8	5-3/4	12	10.35	17.88
15	.1800	3-3/8	5-3/4	12	10.35	17.88
16	.1770	3-3/8	5-3/4	12	10.35	17.88
17	.1730	3-3/8	5-3/4	12	10.35	17.88
18	.1695	3-3/8	5-3/4	12	10.35	17.88
19	.1660	3-3/8	5-3/4	12	10.35	17.88
20	.1610	3-3/8	5-3/4	12	10.35	17.88
21	.1590	3-3/8	5-3/4	12	10.35	17.88
22	.1570	3-3/8	5-3/4	12	10.35	17.88
23	.1540	3	5-3/8	12	10.35	17.88
24	.1520	3	5-3/8	12	10.35	17.88
25	.1495	3	5-3/8	12	10.35	17.88
26	.1470	3	5-3/8	12	10.35	17.88
27	.1440	3	5-3/8	12	10.35	17.88
28	.1405	3	5-3/8	12	10.35	15.85
29	.1360	3	5-3/8	12	10.35	15.85
30	.1285	3	5-3/8	12	10.35	15.85
31	.1200	2-3/4	5-1/8	12	10.20	14.71
32	.1160	2-3/4	5-1/8	12	10.20	14.71
33	.1130	2-3/4	5-1/8	12	10.20	14.71
34	.1110	2-3/4	5-1/8	12	10.20	14.71
35	.1100	2-3/4	5-1/8	12	10.20	14.71
36	.1065	2-1/2	4-5/8	12	7.63	14.30
37	.1040	2-1/2	4-5/8	12	7.63	14.30
38	.1015	2-1/2	4-5/8	12	7.63	14.30
39	.0995	2-1/2	4-5/8	12	6.62	14.30
40	.0980	2-1/2	4-5/8	12	6.62	14.30

Size	Dec. Equiv.	Flute Length	Overall Length	Pkg. Qty.	Price Each	
					H.S. List No. 400	Cobalt List No. 410C*
41	.0960	2-1/2	4-5/8	12	6.62	14.30
42	.0935	2-1/4	4-1/4	12	5.63	13.20
43	.0890	2-1/4	4-1/4	12	5.63	13.20
44	.0860	2-1/4	4-1/4	12	5.63	13.20
45	.0820	2-1/4	4-1/4	12	5.63	13.20
46	.0810	2-1/4	4-1/4	12	5.63	13.20
47	.0785	2-1/4	4-1/4	12	5.63	13.20
48	.0760	2	3-3/4	12	4.67	12.50
49	.0730	2	3-3/4	12	4.67	12.50
50	.0700	2	3-3/4	12	4.67	12.50
51	.0670	2	3-3/4	12	4.67	12.50
52	.0635	2	3-3/4	12	4.67	12.50
53	.0595	1-3/4	3	12	4.67	12.50
54	.0550	1-3/4	3	12	4.67	12.50
55	.0520	1-3/4	3	12	4.67	12.50
56	.0465	1-1/8	2-1/4	12	4.67	12.50
57	.0430	1-1/8	2-1/4	12	4.67	12.50
58	.0420	1-1/8	2-1/4	12	4.67	12.50
59	.0410	1-1/8	2-1/4	12	4.67	12.50
60	.0400	1-1/8	2-1/4	12	4.67	12.50
61	.0390	1-1/8	2-1/4	12	4.50	—
62	.0380	3/4	2	12	5.67	—
63	.0370	3/4	2	12	5.67	—
64	.0360	3/4	2	12	5.67	—
65	.0350	3/4	2	12	5.67	—
66	.0330	3/4	2	12	5.67	—
67	.0320	3/4	2	12	5.67	—
68	.0310	3/4	2	12	5.67	13.30
69	.0292	3/4	2	12	5.67	13.30
70	.0280	3/4	2	12	5.99	—
71	.0260	3/4	2	12	5.99	—
72	.0250	5/16	1-1/2	12	5.99	—
73	.0240	5/16	1-1/2	12	5.99	—
74	.0225	5/16	1-1/2	12	5.99	—
75	.0210	5/16	1-1/2	12	5.99	—
76	.0200	5/16	1-1/2	12	7.17	—
77	.0180	5/16	1-1/2	12	7.24	—
78	.0160	5/16	1-1/2	12	7.24	14.50
79	.0145	5/16	1-1/2	12	7.24	14.50
80	.0135	5/16	1-1/2	12	7.24	14.50

*Cobalt sizes 53 - 80 are furnished with 135° not split.

LETTER SIZES

Size	Dec. Equiv.	Flute Length	Overall Length	Pkg. Qty.	Price Each	
					H.S. List No. 400	Cobalt List No. 410C
A	.2340	3-3/4	6-1/8	12	13.20	22.27
B	.2380	3-3/4	6-1/8	12	13.20	22.27
C	.2420	3-3/4	6-1/8	12	13.20	22.27
D	.2460	3-3/4	6-1/8	12	13.35	22.27
E	.2500	3-3/4	6-1/8	12	8.65	17.09
F	.2570	3-7/8	6-1/4	12	13.98	26.50
G	.2610	3-7/8	6-1/4	12	14.51	26.50
H	.2660	3-7/8	6-1/4	12	15.07	26.50
I	.2720	3-7/8	6-1/4	12	15.07	26.50
J	.2770	3-7/8	6-1/4	6	15.07	26.50
K	.2810	3-7/8	6-1/4	6	15.07	26.50
L	.2900	4	6-3/8	6	16.14	26.50
M	.2950	4	6-3/8	6	16.14	26.50

Size	Dec. Equiv.	Flute Length	Overall Length	Pkg. Qty.	Price Each	
					H.S. List No. 400	Cobalt List No. 410C
N	.3020	4	6-3/8	6	16.44	26.50
O	.3160	4-1/8	6-1/2	6	16.44	29.12
P	.3230	4-1/8	6-1/2	6	16.44	29.12
Q	.3320	4-1/8	6-1/2	6	16.44	29.12
R	.3390	4-1/8	6-1/2	6	17.32	29.12
S	.3480	4-1/4	6-3/4	6	17.32	35.90
T	.3580	4-1/4	6-3/4	6	17.32	35.90
U	.3680	4-1/4	6-3/4	6	18.20	35.90
V	.3770	4-3/8	7	6	18.20	37.12
W	.3860	4-3/8	7	6	18.20	37.12
X	.3970	4-3/8	7	6	18.76	37.12
Y	.4040	4-3/8	7	6	18.76	37.12
Z	.4130	4-5/8	7-1/4	6	19.47	39.90

HIGH SPEED STEEL

TAPER LENGTH DRILLS

FAST SPIRAL

● LIST NO. 400F — BRIGHT FINISH, 118° POINT

Please order in package quantity.



These drills have been especially designed for use through long bushings or where extra length is required. They are recommended for drilling deep holes in nonferrous materials such as aluminum, zinc die cast, magnesium, copper and some plastics.



FRACTIONAL SIZES

Size	Dec. Equiv.	Flute Length	Overall Length	Pkg. Qty.	Price Each	Size	Dec. Equiv.	Flute Length	Overall Length	Pkg. Qty.	Price Each	Size	Dec. Equiv.	Flute Length	Overall Length	Pkg. Qty.	Price Each
3/64	.0469	1-1/8	2-1/4	12	4.85	7/32	.2188	3-5/8	6	12	11.53	25/64	.3906	4-3/8	7	6	19.44
1/16	.0625	1-3/4	3	12	4.77	15/64	.2344	3-3/4	6-1/8	12	13.24	13/32	.4062	4-3/8	7	6	18.41
5/64	.0781	2	3-3/4	12	4.77	1/4	.2500	3-3/4	6-1/8	12	12.49	27/64	.4219	4-5/8	7-1/4	6	22.50
3/32	.0938	2-1/4	4-1/4	12	5.16	17/64	.2656	3-7/8	6-1/4	12	13.68	7/16	.4375	4-5/8	7-1/4	6	20.88
7/64	.1094	2-1/2	4-5/8	12	7.17	9/32	.2812	3-7/8	6-1/4	6	13.06	29/64	.4531	4-3/4	7-1/2	6	25.56
1/8	.1250	2-3/4	5-1/8	12	8.71	19/64	.2969	4	6-3/8	6	14.09	15/32	.4688	4-3/4	7-1/2	6	24.18
9/64	.1406	3	5-3/8	12	9.59	5/16	.3125	4	6-3/8	6	13.47	31/64	.4844	4-3/4	7-3/4	6	27.51
5/32	.1562	3	5-3/8	12	9.49	21/64	.3281	4-1/8	6-1/2	6	15.51	1/2	.5000	4-3/4	7-3/4	6	26.02
11/64	.1719	3-3/8	5-3/4	12	11.26	11/32	.3438	4-1/8	6-1/2	6	14.80	39/64	.6094	4-7/8	8-3/4	1	54.50
3/16	.1875	3-3/8	5-3/4	12	10.64	23/64	.3594	4-1/4	6-3/4	6	17.67	11/16	.6875	5-3/8	9-1/4	1	58.50
13/64	.2031	3-5/8	6	12	12.20	3/8	.3750	4-1/4	6-3/4	6	16.39						

LETTER SIZES

Size	Dec. Equiv.	Flute Length	Overall Length	Pkg. Qty.	Price Each	Size	Dec. Equiv.	Flute Length	Overall Length	Pkg. Qty.	Price Each	Size	Dec. Equiv.	Flute Length	Overall Length	Pkg. Qty.	Price Each
A	.2340	3-3/4	6-1/8	12	19.60	J	.2770	3-7/8	6-1/4	6	19.80	S	.3480	4-1/4	6-3/4	6	25.90
B	.2380	3-3/4	6-1/8	12	19.60	K	.2810	3-7/8	6-1/4	6	21.35	T	.3580	4-1/4	6-3/4	6	24.84
C	.2420	3-3/4	6-1/8	12	19.60	L	.2900	4	6-3/8	6	21.38	U	.3680	4-1/4	6-3/4	6	24.84
D	.2460	3-3/4	6-1/8	12	19.60	M	.2950	4	6-3/8	6	21.38	V	.3770	4-3/8	7	26.85	
E	.2500	3-3/4	6-1/8	12	12.49	N	.3020	4-1/8	6-1/2	6	22.79	W	.3860	4-3/8	7	26.85	
F	.2570	3-7/8	6-1/4	12	19.80	O	.3160	4-1/8	6-1/2	6	22.79	X	.3970	4-3/8	7	28.60	
G	.2610	3-7/8	6-1/4	12	19.80	P	.3230	4-1/8	6-1/2	6	22.79	Y	.4040	4-3/8	7	28.60	
H	.2660	3-7/8	6-1/4	12	20.50	Q	.3320	4-1/8	6-1/2	6	22.79	Z	.4130	4-5/8	7-1/4	6	28.60
I	.2720	3-7/8	6-1/4	6	19.80	R	.3390	4-1/8	6-1/2	6	22.79						

WIRE GAUGE SIZES

Size	Dec. Equiv.	Flute Length	Overall Length	Pkg. Qty.	Price Each	Size	Dec. Equiv.	Flute Length	Overall Length	Pkg. Qty.	Price Each	Size	Dec. Equiv.	Flute Length	Overall Length	Pkg. Qty.	Price Each
1	.2280	3-3/4	6-1/8	12	13.60	21	.1590	3-3/8	5-3/4	12	12.23	41	.0960	2-1/2	4-5/8	12	7.65
2	.2210	3-3/4	6-1/8	12	13.60	22	.1570	3-3/8	5-3/4	12	12.04	42	.0935	2-1/4	4-1/4	12	6.48
3	.2130	3-5/8	6	12	13.13	23	.1540	3	5-3/8	12	12.04	43	.0890	2-1/4	4-1/4	12	6.48
4	.2090	3-5/8	6	12	13.13	24	.1520	3	5-3/8	12	12.04	44	.0860	2-1/4	4-1/4	12	6.48
5	.2055	3-5/8	6	12	13.13	25	.1495	3	5-3/8	12	11.92	45	.0820	2-1/4	4-1/4	12	6.48
6	.2040	3-5/8	6	12	13.13	26	.1470	3	5-3/8	12	11.92	46	.0810	2-1/4	4-1/4	12	6.48
7	.2010	3-5/8	6	12	13.13	27	.1440	3	5-3/8	12	11.92	47	.0785	2-1/4	4-1/4	12	6.48
8	.1990	3-5/8	6	12	13.25	28	.1405	3	5-3/8	12	11.92	48	.0760	2	3-3/4	12	5.05
9	.1960	3-5/8	6	12	13.25	29	.1360	3	5-3/8	12	11.92	49	.0730	2	3-3/4	12	5.05
10	.1935	3-5/8	6	12	13.25	30	.1285	3	5-3/8	12	11.92	50	.0700	2	3-3/4	12	5.05
11	.1910	3-5/8	6	12	13.25	31	.1200	2-3/4	5-1/8	12	11.61	51	.0670	2	3-3/4	12	5.05
12	.1890	3-5/8	6	12	13.25	32	.1160	2-3/4	5-1/8	12	11.61	52	.0635	2	3-3/4	12	5.05
13	.1850	3-3/8	5-3/4	12	13.07	33	.1130	2-3/4	5-1/8	12	11.61	53	.0595	1-3/4	3	12	5.10
14	.1820	3-3/8	5-3/4	12	13.07	34	.1110	2-3/4	5-1/8	12	11.61	54	.0550	1-3/4	3	12	5.10
15	.1800	3-3/8	5-3/4	12	13.07	35	.1100	2-3/4	5-1/8	12	11.61	55	.0520	1-3/4	3	12	5.10
16	.1770	3-3/8	5-3/4	12	13.07	36	.1065	2-1/2	4-5/8	12	8.73	56	.0465	1-1/8	2-1/4	12	5.15
17	.1730	3-3/8	5-3/4	12	13.07	37	.1040	2-1/2	4-5/8	12	8.73	57	.0430	1-1/8	2-1/4	12	5.15
18	.1695	3-3/8	5-3/4	12	13.07	38	.1015	2-1/2	4-5/8	12	8.73	58	.0420	1-1/8	2-1/4	12	5.15
19	.1660	3-3/8	5-3/4	12	12.24	39	.0995	2-1/2	4-5/8	12	7.65	59	.0410	1-1/8	2-1/4	12	5.17
20	.1610	3-3/8	5-3/4	12	12.24	40	.0980	2-1/2	4-5/8	12	7.65	60	.0400	1-1/8	2-1/4	12	5.17

Tanged shanks available. Please inquire.

HIGH SPEED STEEL

FAST SPIRAL DRILLS - SPECIAL LENGTHS

■ LIST NO. 400FS

Size	Flute Length	Overall Length	Price Each	Size	Flute Length	Overall Length	Price Each	Size	Flute Length	Overall Length	Price Each	Size	Flute Length	Overall Length	Price Each
69	5/8	3	4.30	37	2-1/4	7	7.50	21	3/4	1-1/2	1.00	11	7/8	1-7/8	1.48
59	5/8	3	4.30	36	2-1/4	4	5.35	21	7/8	1-7/8	1.15	1	3-9/16	5-1/8	7.50
59	2	5	4.85	30	1-3/8	3-3/8	3.45	20	7/8	1-7/8	1.15	"F"	1-1/4	3-3/4	2.40
58	1/4	1-1/4	.95	30	2	5	5.85	20	1-3/8	3-3/8	1.20	5/16	5-1/2	8	13.80
53	2	5	4.85	30	2-1/2	3-1/2	3.90	11/64	7/8	2-1/2	1.35	"O"	1-1/4	1-7/8	2.58
1/16	1	4	2.50	29	3/4	2-5/8	1.10	3/16	1-3/8	3-3/8	1.53	"O"	1-1/4	3-3/4	3.50
46	2-1/4	3-5/8	2.95	29	1	1-5/8	.95	3/16	1-1/2	4	1.48	"P"	7/8	1-7/8	2.50
40	1-3/8	3-3/8	3.55	27	2	7	7.50	12	1	2	1.60	"P"	1-1/4	3-1/4	3.50
40	2-1/2	3-1/2	4.25												

Subject to prior sale.

SCREW MACHINE LENGTH DRILLS



- ▶ LIST NO. 600 — HIGH SPEED STEEL, BRIGHT FINISH, 118° STANDARD POINT
- ▶ LIST NO. 600A — HIGH SPEED STEEL, OXIDE FINISH, 135° SPLIT POINT (NAS 907 TYPE C)
- ▶ LIST NO. 600T — TITANIUM NITRIDE COATED, 118° STANDARD POINT

Please order in package quantity.



SET NO. 607W
60 Piece High Speed
Surface Treated
Screw Machine Set
No. 1-60 Set with Metal Index
SET PRICE — \$117.00

SET NO. 607WB
60 Piece Bright Finish
Screw Machine Set
No. 1-60 Set with Metal Index
SET PRICE — \$110.00

WIRE GAUGE SIZES

12 drills per package

Size	Dec. Equiv.	Flute Length	Overall Length	Price Each		
				H.S. Bright List No. 600	H.S. Oxide List No. 600A	H.S. TiN Coated List No. 600T
1	.2280	1-5/16	2-7/16	2.82	3.01	7.21
2	.2210	1-5/16	2-7/16	2.82	3.01	7.21
3	.2130	1-1/4	2-3/8	2.67	2.81	7.02
4	.2090	1-1/4	2-3/8	2.67	2.81	7.02
5	.2055	1-1/4	2-3/8	2.67	2.81	7.02
6	.2040	1-1/4	2-3/8	2.67	2.81	7.02
7	.2010	1-3/16	2-1/4	2.22	2.35	6.45
8	.1990	1-3/16	2-1/4	2.22	2.35	6.45
9	.1960	1-3/16	2-1/4	2.22	2.35	6.45
10	.1935	1-3/16	2-1/4	2.22	2.35	6.45
11	.1910	1-3/16	2-1/4	2.22	2.35	6.45
12	.1890	1-3/16	2-1/4	2.22	2.35	6.45
13	.1850	1-1/8	2-3/16	2.22	2.35	6.45
14	.1820	1-1/8	2-3/16	2.22	2.35	6.45
15	.1800	1-1/8	2-3/16	2.22	2.35	6.45
16	.1770	1-1/8	2-3/16	2.22	2.35	6.45
17	.1730	1-1/8	2-3/16	2.22	2.35	6.45
18	.1695	1-1/16	2-1/8	1.91	1.97	6.09
19	.1660	1-1/16	2-1/8	1.91	1.97	6.09
20	.1610	1-1/16	2-1/8	1.91	1.97	6.09
21	.1590	1-1/16	2-1/8	1.83	1.90	5.99
22	.1570	1-1/16	2-1/8	1.83	1.90	5.99
23	.1540	1	2-1/16	1.83	1.90	5.99
24	.1520	1	2-1/16	1.83	1.90	5.99
25	.1495	1	2-1/16	1.78	1.86	5.89
26	.1470	1	2-1/16	1.78	1.86	5.89
27	.1440	1	2-1/16	1.57	1.86	5.89
28	.1405	15/16	1-15/16	1.57	1.69	5.68
29	.1360	15/16	1-15/16	1.57	1.69	5.68
30	.1285	15/16	1-15/16	1.57	1.69	5.68
31	.1200	7/8	1-7/8	1.57	1.69	3.77

Size	Dec. Equiv.	Flute Length	Overall Length	Price Each		
				H.S. Bright List No. 600	H.S. Oxide List No. 600A	H.S. TiN Coated List No. 600T
32	.1160	7/8	1-7/8	1.57	1.69	3.77
33	.1130	7/8	1-7/8	1.57	1.69	3.77
34	.1110	7/8	1-7/8	1.57	1.69	3.77
35	.1100	7/8	1-7/8	1.57	1.69	3.77
36	.1065	13/16	1-13/16	1.57	1.69	3.77
37	.1040	13/16	1-13/16	1.57	1.69	3.77
38	.1015	13/16	1-13/16	1.57	1.69	3.77
39	.0995	13/16	1-13/16	1.57	1.69	3.77
40	.0980	13/16	1-13/16	1.57	1.69	3.77
41	.0960	13/16	1-13/16	1.57	1.69	3.77
42	.0935	3/4	1-3/4	1.57	1.69	3.77
43	.0890	3/4	1-3/4	1.57	1.69	3.77
44	.0860	3/4	1-3/4	1.57	1.69	3.77
45	.0820	3/4	1-3/4	1.57	1.69	3.77
46	.0810	3/4	1-3/4	1.57	1.69	3.77
47	.0785	3/4	1-3/4	1.57	1.69	3.77
48	.0760	11/16	1-11/16	1.57	1.69	3.77
49	.0730	11/16	1-11/16	1.57	1.69	3.77
50	.0700	11/16	1-11/16	1.57	1.69	3.77
51	.0670	11/16	1-11/16	1.57	1.69	3.77
52	.0635	11/16	1-11/16	1.57	1.69	3.77
53	.0595	5/8	1-5/8	1.57	1.69*	3.77
54	.0550	5/8	1-5/8	1.57	1.69*	3.77
55	.0520	5/8	1-5/8	1.57	1.69*	3.77
56	.0465	1/2	1-3/8	1.57	1.69*	3.77
57	.0430	1/2	1-3/8	1.57	1.69*	3.77
58	.0420	1/2	1-3/8	1.57	1.69*	3.77
59	.0410	1/2	1-3/8	1.57	1.69*	3.77
60	.0400	1/2	1-3/8	1.57	1.69*	3.77
61	.0390	1/2	1-1/4	1.70	—	3.92

*Sizes 53 - 60 are furnished with 135° — NOT Split.

LETTER SIZES

Size	Dec. Equiv.	Flute Length	Overall Length	Pkg. Qty.	Price Each	
					H.S. Bright List No. 600	H.S. Oxide List No. 600A
A	.2340	1-5/16	2-7/16	12	3.39	3.48
B	.2380	1-3/8	2-1/2	12	3.39	3.48
C	.2420	1-3/8	2-1/2	12	3.39	3.48
D	.2460	1-3/8	2-1/2	12	3.39	3.48
E	.2500	1-3/8	2-1/2	12	3.18	3.18
F	.2570	1-7/16	2-5/8	12	3.71	3.87
G	.2610	1-7/16	2-5/8	12	3.92	4.09
H	.2660	1-1/2	2-11/16	12	3.92	4.09
I	.2720	1-1/2	2-11/16	6	3.92	4.09
J	.2770	1-1/2	2-11/16	6	4.26	4.39
K	.2810	1-1/2	2-11/16	6	4.55	4.73
L	.2900	1-9/16	2-3/4	6	4.55	4.73
M	.2950	1-9/16	2-3/4	6	4.97	5.16

Size	Dec. Equiv.	Flute Length	Overall Length	Pkg. Qty.	Price Each	
					H.S. Bright List No. 600	H.S. Oxide List No. 600A
N	.3020	1-5/8	2-13/16	6	4.97	5.16
O	.3160	1-11/16	2-15/16	6	5.10	5.21
P	.3230	1-11/16	2-15/16	6	5.61	5.82
Q	.3320	1-11/16	3	6	5.61	5.82
R	.3390	1-11/16	3	6	5.61	5.91
S	.3480	1-3/4	3-1/16	6	6.54	6.71
T	.3580	1-3/4	3-1/16	6	7.55	7.78
U	.3680	1-13/16	3-1/8	6	7.55	7.78
V	.3770	1-7/8	3-1/4	6	7.96	8.31
W	.3860	1-7/8	3-1/4	6	8.35	8.74
X	.3970	1-15/16	3-5/16	6	9.73	10.13
Y	.4040	1-15/16	3-5/16	6	11.54	11.99
Z	.4130	2	3-3/8	6	11.54	11.99

MAINTENANCE SCREW MACHINE DRILLS



► LIST NO. X600
 Please order in package quantity.



SET NO. X607F
 29 Piece High Speed
 Maintenance Screw
 Machine Fractional Set
 1/16 - 1/2 x 64ths in Metal Case
SET PRICE — \$95.00

FRACTIONAL SIZES

Size	Flute Length	Overall Length	Price Each
3/64	1/2	1-3/8	1.12
1/16	5/8	1-5/8	1.04
5/64	11/16	1-11/16	1.04
3/32	3/4	1-3/4	1.04
7/64	13/16	1-13/16	1.04
1/8	7/8	1-7/8	1.04
9/64	15/16	1-15/16	1.04
5/32	1	2-1/16	1.19
11/64	1-1/16	2-1/8	1.28
3/16	1-1/8	2-3/16	1.31
13/64	1-3/16	2-1/4	1.46
7/32	1-1/4	2-3/8	1.70
15/64	1-5/16	2-7/16	1.77
1/4	1-3/8	2-1/2	1.98
17/64	1-7/16	2-5/8	2.16
9/32	1-1/2	2-11/16	2.29
19/64	1-9/16	2-3/4	2.50
5/16	1-5/8	2-13/16	2.70
21/64	1-11/16	2-15/16	2.98
11/32	1-11/16	3	3.35
23/64	1-3/4	3-1/16	3.91
3/8	1-13/16	3-1/8	4.06
25/64	1-7/8	3-1/4	4.52
13/32	1-15/16	3-5/16	4.73
27/64	2	3-3/8	5.19
7/16	2-1/16	3-7/16	5.27

3/64 — 17/64 12 Pc. Per Pkg.

Size	Flute Length	Overall Length	Price Each
29/64	2-1/8	3-9/16	6.33
15/32	2-1/8	3-5/8	6.61
31/64	2-3/16	3-11/16	6.94
1/2	2-1/4	3-3/4	6.82
33/64	2-3/8	3-7/8	15.27
17/32	2-3/8	3-7/8	15.69
35/64	2-1/2	4	16.65
9/16	2-1/2	4	16.35
37/64	2-5/8	4-1/8	19.08
19/32	2-5/8	4-1/8	18.71
39/64	2-3/4	4-1/4	19.23
5/8	2-3/4	4-1/4	18.89
41/64	2-7/8	4-1/2	22.09
21/32	2-7/8	4-1/2	21.69
43/64	2-7/8	4-5/8	24.50
11/16	2-7/8	4-5/8	24.05
45/64	3	4-3/4	27.32
23/32	3	4-3/4	26.34
47/64	3-1/8	5	28.84
3/4	3-1/8	5	27.81
49/64	3-1/4	5-1/8	31.75
25/32	3-1/4	5-1/8	30.61
51/64	3-3/8	5-1/4	33.42
13/16	3-3/8	5-1/4	32.23
53/64	3-1/2	5-3/8	35.39
27/32	3-1/2	5-3/8	34.12
55/64	3-1/2	5-1/2	36.65

9/32 — 1/2 6 Pc. Per Pkg.

Size	Flute Length	Overall Length	Price Each
7/8	3-1/2	5-1/2	35.34
57/64	3-5/8	5-5/8	38.05
29/32	3-5/8	5-5/8	36.69
59/64	3-3/4	5-3/4	41.94
15/16	3-3/4	5-3/4	40.44
61/64	3-7/8	5-7/8	45.62
31/32	3-7/8	5-7/8	43.99
63/64	4	6	47.33
1	4	6	45.64
1-1/16	4	6-1/4	56.93
1-1/8	4	6-3/8	64.51
1-5/32	4-1/4	6-5/8	66.91
1-3/16	4-1/4	6-5/8	74.83
1-1/4	4-3/8	6-3/4	99.83
1-5/16	4-3/8	7	106.42
1-3/8	4-1/2	7-1/8	114.11
1-7/16	4-3/4	7-3/8	129.94
1-1/2	4-7/8	7-1/2	120.30
1-9/16	4-7/8	7-3/4	135.92
1-5/8	4-7/8	7-3/4	152.50
1-11/16	5-1/8	8	174.37
1-3/4	5-1/8	8	180.64
1-13/16	5-3/8	8-1/4	198.19
1-7/8	5-3/8	8-1/4	203.83
1-15/16	5-5/8	8-1/2	216.22
2	5-5/8	8-1/2	227.19
2-3/16	5-5/8	8-1/2	287.30

33/64 — 2-3/16 1 Pc. Per Pkg.

WIRE GAUGE SIZES

Size	Flute Length	Overall Length	Price Each
1	1-5/16	2-7/16	1.83
2	1-5/16	2-7/16	1.83
3	1-1/4	2-3/8	1.74
4	1-1/4	2-3/8	1.74
5	1-1/4	2-3/8	1.74
6	1-1/4	2-3/8	1.74
7	1-3/16	2-1/4	1.44
8	1-3/16	2-1/4	1.44
9	1-3/16	2-1/4	1.44
10	1-3/16	2-1/4	1.44
11	1-3/16	2-1/4	1.44
12	1-3/16	2-1/4	1.44
13	1-1/8	2-3/16	1.44
14	1-1/8	2-3/16	1.44
15	1-1/8	2-3/16	1.44
16	1-1/8	2-3/16	1.44
17	1-1/8	2-3/16	1.44
18	1-1/16	2-1/8	1.24
19	1-1/16	2-1/8	1.24
20	1-1/16	2-1/8	1.24

1 — 60 12 Pc. Per Pkg.

Size	Flute Length	Overall Length	Price Each
21	1-1/16	2-1/8	1.19
22	1-1/16	2-1/8	1.19
23	1	2-1/16	1.19
24	1	2-1/16	1.19
25	1	2-1/16	1.16
26	1	2-1/16	1.16
27	1	2-1/16	1.02
28	15/16	1-15/16	1.02
29	15/16	1-15/16	1.02
30	15/16	1-15/16	1.02
31	7/8	1-7/8	1.02
32	7/8	1-7/8	1.02
33	7/8	1-7/8	1.02
34	7/8	1-7/8	1.02
35	7/8	1-7/8	1.02
36	13/16	1-13/16	1.02
37	13/16	1-13/16	1.02
38	13/16	1-13/16	1.02
39	13/16	1-13/16	1.02
40	13/16	1-13/16	1.02

Size	Flute Length	Overall Length	Price Each
41	13/16	1-13/16	1.02
42	3/4	1-3/4	1.02
43	3/4	1-3/4	1.02
44	3/4	1-3/4	1.02
45	3/4	1-3/4	1.02
46	3/4	1-3/4	1.02
47	3/4	1-3/4	1.02
48	11/16	1-11/16	1.02
49	11/16	1-11/16	1.02
50	11/16	1-11/16	1.02
51	11/16	1-11/16	1.02
52	11/16	1-11/16	1.02
53	5/8	1-5/8	1.02
54	5/8	1-5/8	1.02
55	5/8	1-5/8	1.02
56	1/2	1-3/8	1.02
57	1/2	1-3/8	1.02
58	1/2	1-3/8	1.02
59	1/2	1-3/8	1.02
60	1/2	1-3/8	1.02

LETTER SIZES

Size	Flute Length	Overall Length	Price Each
A	1-5/16	2-7/16	2.20
B	1-3/8	2-1/2	2.20
C	1-3/8	2-1/2	2.20
D	1-3/8	2-1/2	2.20
E	1-3/8	2-1/2	1.98
F	1-7/16	2-5/8	2.41
G	1-7/16	2-5/8	2.55
H	1-1/2	2-11/16	2.55
I	1-1/2	2-11/16	2.55

A — H 12 Pc. Per Pkg.

Size	Flute Length	Overall Length	Price Each
J	1-1/2	2-11/16	2.77
K	1-1/2	2-11/16	2.96
L	1-9/16	2-3/4	2.96
M	1-9/16	2-3/4	3.23
N	1-5/8	2-13/16	3.23
O	1-11/16	2-15/16	3.32
P	1-11/16	2-15/16	3.65
Q	1-11/16	3	3.65
R	1-11/16	3	3.65

I — Z 6 Pc. Per Pkg.

Size	Flute Length	Overall Length	Price Each
S	1-3/4	3-1/16	4.25
T	1-3/4	3-1/16	4.91
U	1-13/16	3-1/8	4.91
V	1-7/8	3-1/4	5.17
W	1-7/8	3-1/4	5.43
X	1-15/16	3-5/16	6.32
Y	1-15/16	3-5/16	7.50
Z	2	3-3/8	7.50

HIGH SPEED STEEL

Federal Tool Premium Import

MAINTENANCE REDUCED SHANK DRILLS

1/2" SHANK — SILVER AND DEMING

► LIST NO. X303

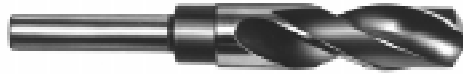

SET NO. X303SA

8 Piece Maintenance Reduced Shank Drill Set 9/16 -1" x 16ths in wood stand

SET PRICE — \$177.00

All sizes 6" overall with 3" flute length.

Size	Price Each
33/64	13.50
17/32	13.50
35/64	14.90
9/16	14.90
37/64	16.03
19/32	16.03
39/64	16.73
5/8	16.73
41/64	17.97
21/32	17.97
43/64	18.90

Size	Price Each
11/16	18.90
45/64	19.20
23/32	19.20
47/64	20.30
3/4	20.30
49/64	21.87
25/32	21.87
51/64	22.80
13/16	22.80
53/64	24.00
27/32	24.00

Size	Price Each
55/64	24.30
7/8	24.30
57/64	26.27
29/32	26.27
59/64	27.26
15/16	27.26
61/64	29.40
31/32	29.40
63/64	32.33
1	32.33
1-1/64	37.80

Size	Price Each
1-1/32	38.67
1-3/64	38.67
1-1/16	38.67
1-5/64	39.67
1-3/32	41.37
1-7/64	42.00
1-1/8	43.47
1-9/64	43.47
1-5/32	43.47
1-11/64	47.30
1-3/16	47.73

Size	Price Each
1-13/64	50.20
1-7/32	51.87
1-15/64	51.87
1-1/4	51.87
1-17/64	59.67
1-9/32	59.67
1-19/64	63.67
1-5/16	63.67
1-21/64	69.30
1-11/32	69.30
1-23/64	72.70

Size	Price Each
1-3/8	72.70
1-25/64	75.60
1-13/32	75.60
1-27/64	80.77
1-7/16	80.77
1-29/64	83.37
1-15/32	83.37
1-31/64	87.90
1-1/2	87.90

HIGH SPEED STEEL

Federal Tool Premium Import

MAINTENANCE TAPER LENGTH DRILLS

► LIST NO. X400

SET NO. X407F

29 Piece Maintenance Taper Length Fractional Set
1/16 - 1/2 x 64ths in metal case

SET PRICE — \$212.99

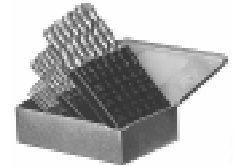

Please order in package quantity

Size	Flute Length	Overall Length	Price Each
1/64	5/16	1-1/2	6.16
1/32	3/4	2	4.50
3/64	1-1/8	2-1/4	2.12
1/16	1-3/4	3	2.20
5/64	2	3-3/4	2.59
3/32	2-1/4	4-1/4	3.09
7/64	2-1/2	4-5/8	3.91
1/8	2-3/4	5-1/8	3.97
9/64	3	5-3/8	4.82
5/32	3	5-3/8	4.82
11/64	3-3/8	5-3/4	4.86
3/16	3-3/8	5-3/4	4.82
13/64	3-5/8	6	5.67
7/32	3-5/8	6	5.62
15/64	3-3/4	6-1/8	5.67
1/4	3-3/4	6-1/8	5.62
17/64	3-7/8	6-1/4	6.94
9/32	3-7/8	6-1/4	6.87
19/64	4	6-3/8	7.03
5/16	4	6-3/8	6.96
21/64	4-1/8	6-1/2	8.05
11/32	4-1/8	6-1/2	7.98
23/64	4-1/4	6-3/4	9.48
3/8	4-1/4	6-3/4	9.39
25/64	4-3/8	7	9.89
13/32	4-3/8	7	9.80
27/64	4-5/8	7-1/4	10.68
7/16	4-5/8	7-1/4	10.78
29/64	4-3/4	7-1/2	12.08
15/32	4-3/4	7-1/2	12.70
31/64	4-3/4	7-3/4	13.38
1/2	4-3/4	7-3/4	13.25

1/64 — 17/64 12 pc. per pkg.

Size	Flute Length	Overall Length	Price Each
33/64	4-3/4	8	18.96
17/32	4-3/4	8	18.77
35/64	4-7/8	8-1/4	19.93
9/16	4-7/8	8-1/4	19.74
37/64	4-7/8	8-3/4	23.30
19/32	4-7/8	8-3/4	23.30
39/64	4-7/8	8-3/4	24.11
5/8	4-7/8	8-3/4	23.87
41/64	5-1/8	9	29.06
21/32	5-1/8	9	27.74
43/64	5-3/8	9-1/4	34.13
11/16	5-3/8	9-1/4	33.00
45/64	5-5/8	9-1/2	35.93
23/32	5-5/8	9-1/2	34.30
47/64	5-7/8	9-3/4	38.64
3/4	5-7/8	9-3/4	36.19
49/64	6	9-7/8	42.43
25/32	6	9-7/8	40.51
51/64	6-1/8	10	45.64
13/16	6-1/8	10	43.15
53/64	6-1/8	10	49.37
27/32	6-1/8	10	45.86
55/64	6-1/8	10	51.86
7/8	6-1/8	10	48.18
57/64	6-1/8	10	54.03
29/32	6-1/8	10	50.19
59/64	6-1/8	10-3/4	58.80
15/16	6-1/8	10-3/4	54.61
61/64	6-3/8	11	64.86
31/32	6-3/8	11	60.24
63/64	6-3/8	11	67.62
1	6-3/8	11	62.80

9/32 — 1/2 6 pc. per pkg.

Size	Flute Length	Overall Length	Price Each
1-1/64	6-1/2	11-1/8	89.12
1-1/32	6-1/2	11-1/8	78.77
1-3/64	6-5/8	11-1/4	92.17
1-1/16	6-5/8	11-1/4	81.46
1-5/64	6-7/8	11-1/2	98.88
1-3/32	6-7/8	11-1/2	87.39
1-7/64	7-1/8	11-3/4	102.63
1-1/8	7-1/8	11-3/4	86.59
1-9/64	7-1/4	11-7/8	103.30
1-5/32	7-1/4	11-7/8	98.73
1-11/64	7-3/8	12	111.22
1-3/16	7-3/8	12	101.47
1-13/64	7-1/2	12-1/8	114.54
1-7/32	7-1/2	12-1/8	104.49
1-15/64	7-7/8	12-1/2	119.13
1-1/4	7-7/8	12-1/2	108.69
1-9/32	8-1/2	14-1/8	126.17
1-5/16	8-5/8	14-1/4	135.85
1-11/32	8-3/4	14-3/8	139.75
1-3/8	8-7/8	14-1/2	145.71
1-13/32	9	14-5/8	152.17
1-7/16	9-1/8	14-3/4	158.78
1-15/32	9-1/4	14-7/8	165.36
1-1/2	9-3/8	15	177.99
1-9/16	9-5/8	15-1/4	199.17
1-5/8	9-7/8	15-5/8	224.88
1-11/16	10-1/8	16	259.78
1-3/4	10-1/2	16-1/4	270.99
1-13/16	10-1/2	16-1/4	323.28
1-15/16	10-3/4	16-5/8	365.95
2	10-3/4	17-1/4	373.10

33/64 — 2 1 pc. per pkg.



REDUCED SHANK DRILLS

1/2" SHANKS — SILVER AND DEMING

▶ LIST NO. 303 — HIGH SPEED STEEL, 118° POINT
1/2" STANDARD SHANK

● LIST NO. 303F — HIGH SPEED STEEL, 118° POINT
1/2" FLATTED SHANK
3-EQUAL FLATS FOR POSITIVE MORE RIGID
HOLDING IN 3-JAW CHUCKS

● LIST NO. 303C — COBALT, 135° NOTCHED POINT
1/2" STANDARD SHANK

● LIST NO. 303CF — COBALT, 135° NOTCHED POINT
1/2" FLATTED SHANK
3-EQUAL FLATS FOR POSITIVE MORE RIGID
HOLDING IN 3-JAW CHUCKS

Heavy web 8% cobalt content permits use at higher speeds in hardened stainless, heat treated and high temperature alloys.

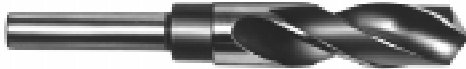

All sizes 6" overall with 3" flute length.

FRACTIONAL SIZES

Size	Dec. Equiv.	Price Each			
		Standard 1/2" Shank		Flatted Shank	
		H.S. List No. 303	Cobalt List No. 303C	H.S. List No. 303F	Cobalt List No. 303CF
1/2	.5000	25.90	37.70	27.40	43.70
33/64	.5156	28.29	46.60	29.73	52.60
17/32	.5312	27.52	46.60	28.91	52.20
35/64	.5469	30.09	48.20	31.62	54.20
9/16	.5625	29.26	48.20	30.76	54.20
37/64	.5781	32.32	51.60	33.97	57.60
19/32	.5938	31.44	51.60	33.04	57.60
39/64	.6094	33.87	54.85	35.59	60.85
5/8	.6250	32.99	54.85	34.61	60.85
41/64	.6406	36.14	61.55	37.96	67.55
21/32	.6562	35.15	61.55	36.93	67.55
43/64	.6719	37.55	64.95	39.45	70.95
11/16	.6875	36.52	64.95	38.38	70.95
45/64	.7031	38.04	69.45	39.98	75.45
23/32	.7188	37.01	69.45	38.88	75.45
47/64	.7344	41.42	69.45	43.52	75.45
3/4	.7500	40.28	69.45	42.33	75.45
49/64	.7656	44.21	78.50	46.45	84.50
25/32	.7812	43.00	78.50	45.20	84.50
51/64	.7969	51.84	82.20	54.49	88.20
13/16	.8125	45.20	82.20	47.47	88.20
53/64	.8281	53.65	89.50	56.37	95.50
27/32	.8438	46.74	89.50	49.10	95.50
55/64	.8594	55.69	89.50	58.52	95.50
7/8	.8750	48.52	88.45	50.98	94.45
57/64	.8906	58.14	94.25	61.12	100.25
29/32	.9062	50.66	94.25	53.25	100.25
59/64	.9219	62.21	94.25	65.40	100.25
15/16	.9375	54.19	94.25	56.98	100.25
61/64	.9531	65.75	105.20	69.09	111.20
31/32	.9688	57.27	105.20	60.19	111.20
63/64	.9844	73.19	114.35	76.92	120.35
1	1.0000	63.77	114.35	67.02	120.35

Size	Dec. Equiv.	Price Each			
		Standard 1/2" Shank		Flatted Shank	
		H.S. List No. 303	Cobalt List No. 303C	H.S. List No. 303F	Cobalt List No. 303CF
1-1/64	1.0156	87.73	—	92.18	—
1-1/32	1.0312	77.79	146.35	81.76	152.35
1-3/64	1.0469	79.96	—	84.05	—
1-1/16	1.0625	74.88	157.95	78.69	163.95
1-5/64	1.0781	82.59	—	86.79	—
1-3/32	1.0938	82.91	168.85	87.12	174.85
1-7/64	1.1094	88.94	—	93.46	—
1-1/8	1.1250	85.09	179.70	89.41	185.70
1-9/64	1.1406	90.87	199.00	95.50	—
1-5/32	1.1562	88.39	188.50	92.89	194.50
1-11/64	1.1719	97.56	—	102.55	—
1-3/16	1.1875	93.41	197.10	98.16	203.10
1-13/64	1.2031	105.05	—	110.41	—
1-7/32	1.2188	104.41	207.70	109.74	213.70
1-15/64	1.2344	107.34	—	112.82	—
1-1/4	1.2500	103.43	218.30	108.71	224.30
1-17/64	1.2656	124.40	—	130.40	—
1-9/32	1.2812	120.78	308.25	126.93	314.25
1-19/64	1.2969	132.50	—	138.50	—
1-5/16	1.3125	128.79	308.25	134.55	314.25
1-21/64	1.3281	142.70	—	148.70	—
1-11/32	1.3438	138.88	312.75	145.98	318.75
1-23/64	1.3594	155.50	—	161.50	—
1-3/8	1.3750	147.23	312.75	154.72	318.75
1-25/64	1.3906	175.40	—	181.40	—
1-13/32	1.4062	171.38	337.95	180.08	343.95
1-27/64	1.4219	175.40	—	181.40	—
1-7/16	1.4375	161.97	337.95	170.19	343.95
1-29/64	1.4531	195.66	—	203.66	—
1-15/32	1.4688	188.48	344.70	198.09	350.70
1-31/64	1.4844	195.66	—	203.66	—
1-1/2	1.5000	178.11	344.70	187.16	350.70

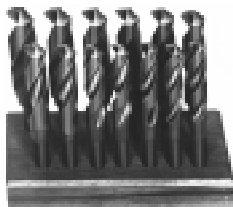

SETS

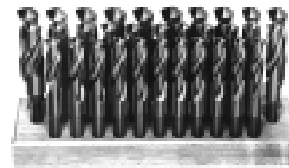

Pcs. Per Set	Set Description	Type of Holder	High Speed Steel Standard 1/2" Shanks		Cobalt Standard 1/2" Shanks	
			Set No.	Price Each	Set No.	Price Each
			8	9/16" thru 1" by 16ths	Metal Index	303SA
8	1-1/16" thru 1-1/2" by 16ths	Wood Block	303SB	980.00	303CB	2060.00
10	9/16" thru 1" by 16ths, 1-1/8" and 1-1/4"	Wood Block	303SJ	539.00	303CS	1024.00
13	17/32" thru 3/4" by 32nds, 13/16", 7/8", 15/16", 31/32" and 1"	Wood Block	303SD	545.00	303CD	959.00
33	1/2" thru 1" by 64ths	Wood Block	303SG	1460.00	303CG	2485.00

REDUCED SHANK DRILLS



1/2" SHANK — SILVER AND DEMING

- LIST NO. 303M — HIGH SPEED STEEL, 118° POINT
- All Sizes 6" overall with 3" flute length

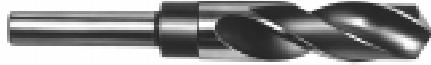

METRIC SIZES

Size	Dec. Equiv.	Price Each	Size	Dec. Equiv.	Price Each	Size	Dec. Equiv.	Price Each
13.00	.5118	32.00	19.00	.7480	46.16	25.00	.9843	79.44
13.50	.5315	33.50	19.50	.7677	49.21	25.50	1.0039	95.18
14.00	.5512	34.70	20.00	.7874	55.87	26.00	1.0236	95.18
14.50	.5709	36.60	20.50	.8071	59.19	26.50	1.0433	95.18
15.00	.5906	36.60	21.00	.8268	59.19	27.00	1.0630	99.16
15.50	.6102	36.60	21.50	.8465	62.11	27.50	1.0827	99.16
16.00	.6299	39.50	22.00	.8661	62.11	28.00	1.1024	106.27
16.50	.6496	39.50	22.50	.8858	66.22	28.50	1.1220	106.27
17.00	.6693	41.12	23.00	.9055	66.22	29.00	1.1417	106.27
17.50	.6890	42.40	23.50	.9252	68.21	30.00	1.1811	116.90
18.00	.7087	42.40	24.00	.9449	71.10	30.50	1.2007	119.77
18.50	.7283	46.16	24.50	.9646	71.10	31.00	1.2205	125.50

1/2" SHANK — SILVER AND DEMING

- LIST NO. 303B — H.S. 135° SPLIT POINT
- GOLD AND BLACK

All Sizes 6" overall with 3" flute length

FRACTIONAL SIZES

Size	Dec. Equiv.	Price Each
17/32	.5312	33.50
9/16	.5625	36.00
19/32	.5938	38.50
5/8	.6250	42.00
21/32	.6562	44.50
11/16	.6875	48.00
23/32	.7188	46.75
3/4	.7500	52.00
13/16	.8125	59.00
7/8	.8750	61.00
15/16	.9375	68.00
1	1.0000	77.00



1/4" SHANK — METAL WORKING

- ▶ LIST NO. 304 — HIGH SPEED STEEL, 118° POINT



FRACTIONAL SIZES

Size	Dec. Equiv.	Price Each	Size	Dec. Equiv.	Price Each
17/64	.2656	7.97	25/64	.3906	13.50
9/32	.2812	7.97	13/32	.4062	12.32
19/64	.2969	8.25	27/64	.4219	14.50
5/16	.3125	8.25	7/16	.4375	13.81
21/64	.3281	9.45	29/64	.4531	17.20
11/32	.3438	9.45	15/32	.4688	15.75
23/64	.3594	11.50	31/64	.4844	17.50
3/8	.3750	10.59	1/2	.5000	16.37

3/4" SHANK — BORING MILL AND SCREW MACHINE

- LIST NO. 306 — HIGH SPEED STEEL, 118° POINT
- LIST NO. 306C — COBALT, 135° NOTCHED POINT



All sizes 6" overall with 3" flute length.

3/8" SHANK — METAL WORKING

- ▶ LIST NO. 308 — HIGH SPEED STEEL, 118° POINT
- LIST NO. 308B — H.S. 135° NOTCHED POINT
- LIST NO. 308C — COBALT, 135° NOTCHED POINT



Size	Dec. Equiv.	Price Each		
		H.S. List No. 308	H.S. List No. 308B	Cobalt List No. 308C
25/64	.3906	13.89	—	24.95
13/32	.4062	13.89	—	25.50
27/64	.4219	14.86	—	29.22
7/16	.4375	13.94	—	29.90
29/64	.4531	17.63	—	32.40
15/32	.4688	16.99	—	32.96
31/64	.4844	17.63	—	33.50
1/2	.5000	16.53	—	33.50
33/64	.5156	30.30	—	50.50
17/32	.5312	29.50	—	52.50
35/64	.5469	32.10	—	53.95
9/16	.5625	32.10	35.00	53.95
37/64	.5781	35.40	—	53.95
19/32	.5938	34.50	—	56.27
39/64	.6094	39.95	—	58.44
5/8	.6250	38.77	41.00	58.44
41/64	.6406	40.44	—	63.11
21/32	.6562	40.44	—	63.11
43/64	.6719	41.92	—	65.25
11/16	.6875	41.92	44.50	65.25
45/64	.7031	42.66	—	68.11
23/32	.7188	42.66	—	68.11
47/64	.7344	46.02	—	69.74
3/4	.7500	47.90	51.00	69.74

SET NO. 308A 3/8" SHANK H.S. DRILL SET

29 Piece Set
Contains 1 piece of each:
1/16" thru 3/8" by 64ths
(Shanks same size as cutting diameters) and
25/64" thru 1/2" by 64ths
(With 3/8" shanks)
Supplied in metal case.
SET PRICE — \$199.00

SET NO. 308D 3/8" SHANK H.S. DRILL SET

8 Piece Set
Contains 1 piece of each:
3/8, 13/32, 7/16, 15/32, 1/2,
17/32, 9/16, 5/8.
Supplied in wood block.
SET PRICE — \$173.00

Size	Dec. Equiv.	Price Each	
		H.S. List No. 306	Cobalt List No. 306C
25/32	.7812	52.20	82.50
13/16	.8125	54.70	85.70
27/32	.8438	58.85	90.70
7/8	.8750	60.92	94.40
29/32	.9062	62.88	103.20
15/16	.9375	67.40	110.50
31/32	.9688	69.99	116.70
1	1.0000	71.51	121.20
1- 1/32	1.0312	85.56	155.60
1- 1/16	1.0625	85.56	165.12
1- 3/32	1.0938	91.21	178.60
1- 1/8	1.1250	95.41	185.12
1- 5/32	1.1562	97.24	192.22
1- 3/16	1.1875	106.75	210.06
1- 7/32	1.2188	115.41	215.40
1- 1/4	1.2500	117.69	225.20
1- 9/32	1.2812	132.34	312.25
1- 5/16	1.3125	137.55	312.25
1- 11/32	1.3438	146.60	315.00
1- 3/8	1.3750	152.30	315.00
1- 13/32	1.4062	160.91	340.30
1- 7/16	1.4375	169.71	340.30
1- 15/32	1.4688	176.78	350.60
1- 1/2	1.5000	181.81	350.60
1- 17/32	1.5312	199.26	—
1- 9/16	1.5625	194.94	385.00
1- 19/32	1.5938	231.80	—
1- 5/8	1.6250	216.75	430.00
1- 21/32	1.6562	265.19	—
1- 11/16	1.6875	248.64	438.16
1- 23/32	1.7188	275.12	—
1- 3/4	1.7500	251.32	499.90
1- 25/32	1.7812	299.20	—
1- 13/16	1.8125	281.67	549.80
1- 27/32	1.8438	306.41	—
1- 7/8	1.8750	287.74	574.77
1- 29/32	1.9062	321.50	—
1- 15/16	1.9375	302.38	599.69
1- 31/32	1.9688	342.65	—
2	2.0000	313.82	639.60

HIGH SPEED SETS

SET NO. 306A
5 Piece Set
Contains 1 piece of each:
1", 1-1/8, 1-1/4, 1-3/8, 1-1/2
Supplied in wood block.
SET PRICE — \$625.00

SET NO. 306B
5 Piece Set
Contains 1 piece of each:
1", 1-1/4, 1-1/2, 1-3/4, 2"
Supplied in wood block.
SET PRICE — \$939.00

COBALT SETS

SET NO. 306D
5 Piece Set
Contains 1 piece of each:
1", 1-1/8, 1-1/4, 1-3/8, 1-1/2
Supplied in wood block.
SET PRICE — \$1185.00

SET NO. 306E
5 Piece Set
Contains 1 piece of each:
1", 1-1/4, 1-1/2, 1-3/4, 2"
Supplied in wood block.
SET PRICE — \$1825.00



HIGH SPEED STEEL

BODY DRILLS

Body Drills are intended primarily for use in hand held, air or electric drill motors, in sheet metal, thin wall tubing or any other shallow hole drilling. Because of their short flute design and heavy web construction, they are considerably more rigid and durable than Jobber or Screw Machine Lengths. Breakage is significantly reduced or eliminated and tool life is greatly increased.

● LIST NO. 650S

SINGLE END

● LIST NO. 650F



STYLE S 135° split point is used in hand or machine drilling without guide bushings, and where burring is not a problem. This point centers quickly and may be used successfully in tougher, harder materials.

STYLE F fishtail point is used in hand drilling thin material or machine drilling where the ratio of hole size to material thickness is very large, and where burr free holes are desired. A guide bushing must be used to center the drill point.

Size	Dec. Equiv.	Price Each					
		2" OAL		2-1/2" OAL		3" OAL	
		Style S	Style F	Style S	Style F	Style S	Style F
3/64	.0469	—	—	1.50	2.47	—	—
47	.0785	1.55	2.52	—	—	—	—
44	.0860	1.63	2.60	—	—	—	—
36	.1065	1.65	2.62	1.73	2.70	—	—
7/64	.1094	—	—	—	—	1.94	2.91
32	.1160	—	—	—	—	1.94	2.91
31	.1200	1.91	2.88	—	—	—	—
1/8	.1250	1.91	2.88	1.96	2.93	2.04	3.01
3.25mm	.1280	—	—	—	—	2.23	3.21
30	.1285	1.91	2.88	—	—	2.04	3.01
3.30mm	.1299	—	—	—	—	2.23	3.20
29	.1360	1.94	2.91	—	—	2.23	3.21
28	.1405	1.94	2.91	2.15	3.12	2.23	3.21
9/64	.1406	1.94	2.91	2.15	3.12	2.23	3.21
27	.1440	2.05	3.02	—	—	—	—
26	.1470	2.19	3.16	—	—	—	—
25	.1495	2.19	3.16	2.47	3.44	—	—
3.8mm	.1496	2.19	3.16	—	—	—	—
24	.1520	—	—	2.56	3.53	—	—
5/32	.1562	2.19	3.16	2.56	3.53	2.59	3.56
22	.1570	—	—	—	—	2.59	3.56
21	.1590	2.39	3.36	—	—	2.70	3.67

Size	Dec. Equiv.	Price Each							
		2" OAL		2-1/2" OAL		3" OAL		4" OAL	
		Style S	Style F	Style S	Style F	Style S	Style F	Style S	Style F
20	.1610	2.39	3.36	—	—	2.70	3.67	—	—
18	.1695	2.39	3.36	2.59	3.56	2.83	3.80	—	—
11/64	.1719	—	—	—	—	2.83	3.80	3.18	4.15
13	.1850	2.39	3.36	—	—	—	—	—	—
3/16	.1875	2.39	3.36	2.63	3.60	2.83	3.80	—	—
8	.1990	2.56	3.53	—	—	—	—	—	—
13/64	.2031	—	—	3.01	3.98	—	—	—	—
7/32	.2188	—	—	3.16	4.13	3.42	4.39	—	—
15/64	.2344	—	—	3.26	4.23	—	—	—	—
6.00mm	.2362	3.18	4.15	—	—	—	—	—	—
1/4	.2500	3.18	4.48	3.15	4.45	3.69	4.99	3.95	5.25
F	.2570	—	—	—	—	4.05	5.35	—	—
17/64	.2656	—	—	—	—	4.25	5.55	—	—
9/32	.2812	—	—	—	—	4.65	5.95	—	—
5/16	.3125	—	—	—	—	4.88	6.18	—	—
11/32	.3438	—	—	—	—	6.15	7.45	—	—
3/8	.3750	—	—	—	—	7.36	8.66	—	—
13/32	.4062	—	—	—	—	8.51	10.26	—	—
27/64	.4219	—	—	—	—	9.00	10.30	—	—
7/16	.4375	—	—	—	—	9.15	10.90	—	—
12.40mm	.4881	7.50	—	—	—	—	—	—	—
1/2	.5000	—	—	—	—	11.70	13.45	—	—

HIGH SPEED STEEL AND COBALT

DOUBLE END — 135° SPLIT POINT

▶ LIST NO. 655S—HIGH SPEED STEEL

▶ LIST NO. 655SC—COBALT STEEL

▶ LIST NO. 655T—H.S. TiN COATED



This drill is recommended for all sheet metal drilling applications. The short overall length and short flute length provide rigidity and reduce breakage.

Size	Dec. Equiv.	Price Each
1/16	.0625	2.74
5/64	.0781	2.74
3/32	.0938	2.74
7/64	.1094	2.74
31	.1200	2.74
1/8	.1250	2.89
30	.1285	2.89
9/64	.1406	3.00

Size	Dec. Equiv.	Price Each
27	.1440	3.15
26	.1470	3.15
25	.1495	3.25
5/32	.1562	3.25
21	.1590	3.75
20	.1610	3.75
11/64	.1719	3.75
3/16	.1875	3.94

Size	Dec. Equiv.	Price Each
7	.2010	4.50
7/32	.2188	5.07
1/4	.2500	6.05
17/64	.2656	7.50
9/32	.2812	7.90
19/64	.2969	9.00
5/16	.3125	9.50

Size	Dec. Equiv.	Price Each	
		Cobalt List No. 655SC	TiN Coated List No. 655T
1/8	.1250	4.50	5.68
30	.1285	4.50	5.68

HIGH SPEED STEEL

SHEETERS DRILLS

● LIST NO. 670S



135° LONG SWEEP SPLIT POINT

These drills are commonly used in drilling automotive and truck bodies, metal building and other sheet metal applications. The 135° long sweep split point insures easy centering while the short overall length reduces breakage in hand held drilling operations.

Size	Overall Length	Price Each
5/32	4-1/2	4.86
#10	4-1/8	5.20
#8	1-3/8	2.88
#8	3-5/8	4.73
#8	4-1/2	5.20

Size	Overall Length	Price Each
7/32	6	7.60
#1	2-1/4	3.37
#1	3	3.71
#1	3-5/8	4.66
#1	3-7/8	4.95

Size	Overall Length	Price Each
#1	4-1/2	5.70
#1	6	7.69
#1	7-1/4	9.47
.231	3	4.02
.231	4-1/2	5.98

EXTRA LENGTH DRILLS

STRAIGHT SHANK, 118° POINT



A Large Stock of Every Size for Immediate Delivery.

Size	Decimal Equivalent	Price Each
18" OAL — 12" FLT		
● LIST NO. 218		
1/8	.1250	49.50
5/32	.1562	49.50
3/16	.1875	47.50
13/64	.2031	47.50
7/32	.2188	47.50
15/64	.2344	47.50
1/4	.2500	47.50
17/64	.2656	53.50
9/32	.2812	51.94
19/64	.2969	53.86
5/16	.3125	50.48
21/64	.3281	57.06
11/32	.3438	55.03
23/64	.3594	57.06
3/8	.3750	53.49
25/64	.3906	61.82
13/32	.4062	59.61
27/64	.4219	66.63
11 mm	.4331	68.40
7/16	.4375	62.45
29/64	.4531	76.31
15/32	.4688	73.59
31/64	.4844	79.50
1/2	.5000	74.50
33/64	.5156	94.47
17/32	.5312	91.10
35/64	.5469	96.03
9/16	.5625	92.60
37/64	.5781	99.40
19/32	.5938	95.85
39/64	.6094	104.30
5/8	.6250	100.59
41/64	.6406	115.60
21/32	.6562	111.17
43/64	.6719	130.10
11/16	.6875	119.09
45/64	.7031	145.70
23/32	.7188	130.17
47/64	.7344	150.80
3/4	.7500	138.02
49/64	.7656	165.50
25/32	.7812	153.95
51/64	.7969	172.50
13/16	.8125	159.83

Size	Decimal Equivalent	Price Each
18" OAL — 12" FLT		
● LIST NO. 218		
53/64	.8281	170.50
27/32	.8438	170.50
55/64	.8594	180.20
7/8	.8750	164.88
57/64	.8906	195.00
29/32	.9062	195.00
59/64	.9219	199.50
15/16	.9375	173.41
61/64	.9531	199.75
31/32	.9688	199.78
63/64	.9844	199.75
1	1.0000	183.85
1-1/8	1.1250	206.25
1-3/16	1.1875	249.50
1-1/4	1.2500	299.70
18" OAL — 12" FLT		
● LIST NO. 218X — 1/2" SHK		
33/64	.5156	90.78
17/32	.5312	101.11
35/64	.5469	106.03
9/16	.5625	102.60
37/64	.5781	109.40
19/32	.5938	105.86
39/64	.6094	114.32
5/8	.6250	110.56
41/64	.6406	125.61
21/32	.6562	127.18
43/64	.6719	140.10
11/16	.6875	129.10
45/64	.7031	155.72
23/32	.7188	140.17
47/64	.7344	160.80
3/4	.7500	148.02
49/64	.7656	177.50
25/32	.7812	165.95
51/64	.7969	184.50
13/16	.8125	171.58
53/64	.8281	182.50
27/32	.8438	182.50
55/64	.8594	192.20
7/8	.8750	176.88

Size	Decimal Equivalent	Price Each
18" OAL — 12" FLT		
● LIST NO. 218X — 1/2" SHK		
57/64	.8906	210.00
29/32	.9062	210.00
59/64	.9219	214.51
15/16	.9375	188.41
61/64	.9531	214.75
31/32	.9688	214.75
63/64	.9844	214.75
1	1.0000	198.85
24" OAL — 18" FLT		
● LIST NO. 224		
1/4	.2500	80.39
5/16	.3125	82.69
3/8	.3750	84.64
7/16	.4375	98.90
1/2	.5000	114.43
9/16	.5625	152.95
5/8	.6250	166.52
11/16	.6875	194.35
3/4	.7500	224.25
25/32	.7812	234.60
13/16	.8125	240.35
27/32	.8438	252.43
7/8	.8750	258.75
15/16	.9375	270.25
1	1.0000	287.50
1-1/8	1.1250	308.20
1-3/16	1.1875	343.85
1-1/4	1.2500	413.43
48" OAL — 5-1/2" FLT		
● LIST NO. 248		
1/4	.2500	76.13
5/16	.3125	82.77
3/8	.3750	93.73
7/16	.4375	102.58
1/2	.5000	112.48
5/8	.6250	158.36
3/4	.7500	217.12

HIGH SPEED SETS

Overall Length	Set Description	Pieces Per Set	Set No.	Set Price
8"	1/8" thru 3/8" by 64ths	17	208ES	365.00
10"	3/16" thru 1/2" by 64ths	21	210ES	654.27
12"	1/8" thru 1/2" by 64ths	25	212ES	918.00

Overall Length	Set Description	Pieces Per Set	Set No.	Set Price
12" 1/2 shk	17/32" thru 1" by 32nds	16	212XES	1511.92
18"	3/16" thru 1/2" by 32nds	11	218ES	623.00
18" 1/2 shk	17/32" thru 1" by 32nds	16	218XES	2473.52

EXTRA LENGTH COBALT DRILLS

STRAIGHT SHANK, 135° SPLIT POINT

Size	Decimal Equivalent	Price Each
8" OAL — 5-1/2" FLT		
● LIST NO. 208C		
3/32	.0938	38.91
1/8	.1250	31.30
5/32	.1562	34.21
3/16	.1875	34.80
1/4	.2500	35.74
17/64	.2656	35.87
9/32	.2812	39.50
19/64	.2969	40.89
5/16	.3125	41.90
11/32	.3438	50.56
3/8	.3750	42.64

Size	Decimal Equivalent	Price Each
8" OAL — 5-1/2" FLT		
● LIST NO. 208C		
13/32	.4062	53.47
27/64	.4219	71.23
7/16	.4375	60.24
9" OAL — 6-1/2" FLT		
● LIST NO. 209C		
27/64*	.4219	38.27
11" OAL — 9" FLT		
● LIST NO. 211C		
9/16*	.5625	68.43

Size	Decimal Equivalent	Price Each
12" OAL — 9" FLT		
● LIST NO. 212C		
1/8	.1250	37.52
3/16	.1875	42.44
1/4	.2500	47.40
5/16	.3125	50.89
3/8	.3750	54.65
7/16	.4375	65.03
1/2	.5000	72.98
9/16	.5625	90.89
5/8	.6250	102.56
43/64	.6719	128.95
11/16	.6875	120.23

* Subject to prior sale



HIGH SPEED STEEL

METRIC TAPER SHANK DRILLS

▶ LIST NO. 200M



MILLIMETER SIZES

Size	Dec. Equiv.	Morse Taper No.	Flute Length	Overall Length	Price Each
3.00	.1181	1	1-7/8	5-1/8	18.16
3.20	.1260	1	1-7/8	5-1/8	19.00
3.50	.1378	1	2-1/8	5-3/8	18.16
3.80	.1496	1	2-1/8	5-3/8	19.00
4.00	.1575	1	2-1/8	5-3/8	18.16
4.20	.1654	1	2-1/2	5-3/4	19.00
4.50	.1772	1	2-1/2	5-3/4	14.86
4.80	.1890	1	2-1/2	5-3/4	14.86
5.00	.1969	1	2-3/4	6	14.82
5.20	.2047	1	2-3/4	6	14.86
5.50	.2165	1	2-3/4	6	14.82
5.80	.2283	1	2-7/8	6-1/8	15.46
6.00	.2362	1	2-7/8	6-1/8	15.46
6.20	.2441	1	2-7/8	6-1/8	16.41
6.50	.2559	1	3	6-1/4	16.41
6.80	.2677	1	3	6-1/4	17.15
7.00	.2756	1	3	6-1/4	16.40
7.20	.2835	1	3-1/8	6-3/8	17.30
7.50	.2953	1	3-1/8	6-3/8	16.40
7.80	.3071	1	3-1/8	6-3/8	18.20
8.00	.3150	1	3-1/4	6-1/2	22.28
8.20	.3228	1	3-1/4	6-1/2	23.60
8.50	.3346	1	3-1/4	6-1/2	23.58
8.80	.3465	1	3-1/2	6-3/4	26.50
9.00	.3543	1	3-1/2	6-3/4	25.80
9.20	.3622	1	3-1/2	6-3/4	25.84
9.50	.3740	1	3-1/2	6-3/4	25.84
9.80	.3858	1	3-5/8	7	25.84
10.00	.3937	1	3-5/8	7	25.84
10.20	.4016	1	3-5/8	7	26.55
10.50	.4134	1	3-7/8	7-1/4	28.55
10.80	.4252	1	3-7/8	7-1/4	28.92
11.00	.4331	1	3-7/8	7-1/4	28.80
11.20	.4409	1	4-1/8	7-1/2	31.41
11.50	.4528	1	4-1/8	7-1/2	31.40
11.80	.4646	1	4-1/8	7-1/2	33.89
12.00	.4724	2	4-3/8	8-1/4	33.80
12.20	.4803	2	4-3/8	8-1/4	38.66
12.50	.4921	2	4-3/8	8-1/4	33.80
12.80	.5039	2	4-5/8	8-1/2	39.65
13.00	.5118	2	4-5/8	8-1/2	37.80
13.20	.5197	2	4-5/8	8-1/2	41.33
13.50	.5315	2	4-5/8	8-1/2	41.28
13.80	.5433	2	4-7/8	8-3/4	43.20
14.00	.5512	2	4-7/8	8-3/4	39.40
14.25	.5610	2	4-7/8	8-3/4	45.20
14.50	.5709	2	4-7/8	8-3/4	44.00
14.75	.5807	2	4-7/8	8-3/4	50.26
15.00	.5906	2	4-7/8	8-3/4	42.80
15.25	.6004	2	4-7/8	8-3/4	47.26
15.50	.6102	2	4-7/8	8-3/4	45.10
15.75	.6201	2	4-7/8	8-3/4	47.20
16.00	.6299	2	5-1/8	9	48.44
16.25	.6398	2	5-1/8	9	56.95
16.50	.6496	2	5-1/8	9	49.85
16.75	.6594	2	5-3/8	9-1/4	59.90
17.00	.6693	2	5-3/8	9-1/4	50.08
17.25	.6791	2	5-3/8	9-1/4	59.85
17.50	.6890	2	5-5/8	9-1/2	53.10
18.00	.7087	2	5-5/8	9-1/2	53.10
18.50	.7283	2	5-5/8	9-1/2	61.15
19.00	.7480	2	5-7/8	9-3/4	59.50
19.50	.7677	2	6	9-7/8	73.12
20.00	.7874	3	6	9-7/8	73.64

Size	Dec. Equiv.	Morse Taper No.	Flute Length	Overall Length	Price Each
20.50	.8071	3	6-1/8	10-3/4	81.36
21.00	.8268	3	6-1/8	10-3/4	81.73
21.50	.8465	3	6-1/8	10-3/4	90.30
22.00	.8661	3	6-1/8	10-3/4	81.73
22.50	.8858	3	6-1/8	10-3/4	88.20
23.00	.9055	3	6-1/8	10-3/4	82.05
23.50	.9252	3	6-1/8	10-3/4	90.68
24.00	.9449	3	6-3/8	11	89.24
24.50	.9646	3	6-3/8	11	98.56
25.00	.9843	3	6-3/8	11	95.45
25.50	1.0039	3	6-1/2	11-1/8	110.28
26.00	1.0236	3	6-1/2	11-1/8	99.80
26.50	1.0433	3	6-5/8	11-1/4	124.80
27.00	1.0630	3	6-5/8	11-1/4	123.30
27.50	1.0827	4	6-7/8	12-1/2	138.70
28.00	1.1024	4	7-1/8	12-3/4	129.43
28.50	1.1220	4	7-1/8	12-3/4	151.95
29.00	1.1417	4	7-1/4	12-7/8	134.10
29.50	1.1614	4	7-3/8	13	165.53
30.00	1.1811	4	7-3/8	13	141.00
30.50	1.2008	4	7-1/2	13-1/8	179.10
31.00	1.2205	4	7-7/8	13-1/2	163.14
31.50	1.2402	4	7-7/8	13-1/2	186.28
32.00	1.2598	4	8-1/2	14-1/8	190.30
32.50	1.2795	4	8-1/2	14-1/8	225.55
33.00	1.2992	4	8-5/8	14-1/4	195.20
33.50	1.3189	4	8-3/4	14-3/8	242.15
34.00	1.3386	4	8-3/4	14-3/8	212.00
34.50	1.3583	4	8-7/8	14-1/2	255.75
35.00	1.3780	4	9	14-5/8	230.34
35.50	1.3976	4	9	14-5/8	263.00
36.00	1.4173	4	9-1/8	14-3/4	232.70
36.50	1.4370	4	9-1/8	14-3/4	265.70
37.00	1.4567	4	9-1/4	14-7/8	247.45
37.50	1.4764	4	9-3/8	15	282.55
38.00	1.4961	4	9-3/8	15	247.45
38.50	1.5157	5	9-5/8	16-5/8	326.94
39.00	1.5354	5	9-5/8	16-5/8	326.94
39.50	1.5551	5	9-7/8	16-7/8	326.94
40.00	1.5748	5	9-7/8	16-7/8	326.94
41.00	1.6142	5	10	17	353.10
41.50	1.6338	5	10-1/8	17-1/8	379.74
42.00	1.6535	5	10-1/8	17-1/8	379.70
42.50	1.6732	5	10-1/8	17-1/8	408.48
43.00	1.6929	5	10-1/8	17-1/8	408.48
43.50	1.7125	5	10-1/8	17-1/8	416.86
44.00	1.7323	5	10-1/8	17-1/8	416.86
44.50	1.7519	5	10-1/8	17-1/8	433.07
45.00	1.7717	5	10-1/8	17-1/8	433.05
46.00	1.8110	5	10-1/8	17-1/8	450.00
47.00	1.8504	5	10-3/8	17-3/8	464.90
48.00	1.8898	5	10-3/8	17-3/8	485.10
49.00	1.9291	5	10-3/8	17-3/8	500.15
50.00	1.9685	5	10-3/8	17-3/8	468.55
51.00	2.0079	5	10-3/8	17-3/8	545.50
55.00	2.1653	5	10-3/8	17-3/8	660.05
57.00	2.2441	5	10-3/8	17-3/8	690.00
59.00	2.3228	5	10-3/8	17-3/8	741.35
60.00	2.3622	5	11-7/8	19-1/2	1050.08
65.00	2.5591	5	11-7/8	19-1/2	1050.08
66.00	2.5984	5	11-7/8	19-1/2	1099.12
69.00	2.7165	5	12-3/4	20-3/8	1320.20
70.00	2.7559	5	13-3/8	21-1/8	1395.07
72.00	2.8346	5	13-3/8	21-1/8	1449.25



HIGH SPEED STEEL

TAPER SHANK DRILLS

► LIST NO. 201



Furnished with #1 Morse Taper Shank.

LETTER SIZES

Size	Dec. Equiv.	Flute Length	Overall Length	Price Each
A	.2340	2-7/8	6-1/8	24.89
B	.2380	2-7/8	6-1/8	24.89
C	.2420	2-7/8	6-1/8	24.89
D	.2460	2-7/8	6-1/8	22.08
E	.2500	2-7/8	6-1/8	13.79
F	.2570	3	6-1/4	21.89
G	.2610	3	6-1/4	26.09
H	.2660	3	6-1/4	26.09
I	.2720	3	6-1/4	26.09

Size	Dec. Equiv.	Flute Length	Overall Length	Price Each
J	.2770	3	6-1/4	24.08
K	.2810	3	6-1/4	27.38
L	.2900	3-1/8	6-3/8	27.38
M	.2950	3-1/8	6-3/8	27.38
N	.3020	3-1/8	6-3/8	27.38
O	.3160	3-1/4	6-1/2	32.49
P	.3230	3-1/4	6-1/2	32.49
Q	.3320	3-1/4	6-1/2	34.08
R	.3390	3-1/4	6-1/2	37.49

Size	Dec. Equiv.	Flute Length	Overall Length	Price Each
S	.3480	3-1/2	6-3/4	39.28
T	.3580	3-1/2	6-3/4	39.28
U	.3680	3-1/2	6-3/4	39.28
V	.3770	3-5/8	7	41.39
W	.3860	3-5/8	7	41.39
X	.3970	3-5/8	7	42.68
Y	.4040	3-5/8	7	42.68
Z	.4130	3-7/8	7-1/4	44.59

► LIST NO. 204



Furnished with #1 Morse Taper Shank. Flute length and overall length are approximately the same as corresponding fractional.

WIRE GAUGE SIZES

Size	Dec. Equiv.	Price Each
1	.2280	24.00
2	.2210	24.00
3	.2130	24.00
4	.2090	24.00
5	.2055	24.00
6	.2040	24.00
7	.2010	22.90
8	.1990	22.90
9	.1960	22.90

Size	Dec. Equiv.	Price Each
10	.1935	22.90
11	.1910	22.90
12	.1890	22.90
13	.1850	22.90
14	.1820	22.90
15	.1800	22.90
16	.1770	22.90
17	.1730	22.90
18	.1695	22.90

Size	Dec. Equiv.	Price Each
19	.1660	22.90
20	.1610	21.50
21	.1590	21.50
22	.1570	21.50
23	.1540	21.50
24	.1520	21.50
25	.1495	21.50
26	.1470	21.50
27	.1440	21.50

Size	Dec. Equiv.	Price Each
28	.1405	21.50
29	.1360	21.50
30	.1285	21.50
31	.1200	21.50
37	.1040	21.50
39	.0995	21.50
40	.0980	21.50
44	.0860	21.50
47	.0785	21.50

STUB LENGTH TAPER SHANK DRILLS

■ LIST NO. 200ST — 118° POINT

5" approximate flute length

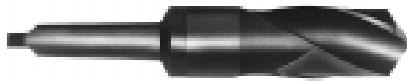

Because of their short overall and flute length, stub length taper shank drills are recommended for use in boring mills, screw machines and lathes or where short projection is required.

Size	Dec. Equiv.	Approx. Overall Length	Morse Taper No.	Price Each
2	2.0000	11	4	218.44
2	2.0000	12	5	224.99
2-1/16	2.0625	11	4	239.40
2-1/16	2.0625	12	5	246.58
2-1/8	2.1250	11	4	259.64
2-1/8	2.1250	12	5	267.40
2-3/16	2.1875	11	4	280.11
2-3/16	2.1875	12	5	288.50
2-1/4	2.2500	11	4	290.49
2-1/4	2.2500	12	5	299.20
2-5/16	2.3125	11	4	299.99

Size	Dec. Equiv.	Approx. Overall Length	Morse Taper No.	Price Each
2-5/16	2.3125	12	5	308.40
2-3/8	2.3750	11	4	310.55
2-3/8	2.3750	12	5	319.88
2-7/16	2.4375	12	5	340.86
2-1/2	2.5000	11	4	349.90
2-1/2	2.5000	12	5	359.90
2-5/8	2.6250	12	5	388.30
2-3/4	2.7500	12	5	440.77
2-7/8	2.8750	12	5	510.50
3	3.0000	12	5	571.10
3-1/4	3.2500	12	5	747.87

COBALT TAPER SHANK DRILLS



● LIST NO. 210C — SUPER COBALT, HEAVY DUTY, 135° NOTCHED POINT



These premium cobalt drills exhibit greater toughness, abrasion resistance and higher red hardness than the standard high speed drills. They are recommended for use on hard-to-machine materials where longer tool life is desired.

Size	Flute Length	Overall Length	Morse Taper No.	Price Each	Size	Flute Length	Overall Length	Morse Taper No.	Price Each	Size	Flute Length	Overall Length	Morse Taper No.	Price Each
1/4	2-7/8	6-1/8	1	26.98	23/32	5-5/8	10-1/4	3	96.00	1-11/64	7-3/8	13	4	304.53
17/64	3	6-1/4	1	28.67	47/64	5-7/8	10-1/2	3	105.85	1-3/16	7-3/8	12	3*	267.91
9/32	3	6-1/4	1	30.33	3/4	5-7/8	10-1/2	3	100.16	1-3/16	7-3/8	13	4	267.91
19/64	3-1/8	6-3/8	1	28.67	49/64	6	10-5/8	3	113.43	1-13/64	7-1/2	13-1/8	4	315.47
5/16	3-1/8	6-3/8	1	30.33	25/32	6	9-7/8	2*	105.35	1-7/32	7-1/2	13-1/8	4	319.82
21/64	3-1/4	6-1/2	1	33.62	25/32	6	10-5/8	3	105.35	1-15/64	7-7/8	13-1/2	4	347.00
11/32	3-1/4	6-1/2	1	35.60	51/64	6-1/8	10-3/4	3	120.40	1-1/4	7-7/8	13-1/2	4	311.12
23/64	3-1/2	6-3/4	1	39.00	13/16	6-1/8	10	2*	108.75	1-17/64	8-1/2	14-1/8	4	373.00
3/8	3-1/2	6-3/4	1*	41.20	13/16	6-1/8	10-3/4	3	108.75	1-9/32	8-1/2	14-1/8	4	373.00
3/8	3-1/2	7-3/8	2	41.20	53/64	6-1/8	10-3/4	3	140.25	1-19/64	8-5/8	14-1/4	4	406.53
25/64	3-5/8	7-1/2	2	42.45	27/32	6-1/8	10-3/4	3	129.15	1-5/16	8-5/8	14-1/4	4*	373.00
13/32	3-5/8	7-1/2	2	43.72	55/64	6-1/8	10-3/4	3	140.24	1-5/16	8-5/8	15-7/8	5	373.00
27/64	3-7/8	7-3/4	2	50.35	7/8	6-1/8	10-3/4	3	129.15	1-21/64	8-3/4	14-3/8	4	401.00
7/16	3-7/8	7-3/4	2	47.20	57/64	6-1/8	10-3/4	3	140.24	1-11/32	8-3/4	14-3/8	4	401.00
29/64	4-1/8	8	2	54.00	29/32	6-1/8	10-3/4	3	126.71	1-23/64	8-7/8	14-1/2	4	436.10
15/32	4-1/8	8	2	50.61	59/64	6-1/8	10-3/4	3	164.90	1-3/8	8-7/8	14-1/2	4*	401.00
31/64	4-3/8	8-1/4	2	55.80	15/16	6-1/8	10-3/4	3	148.95	1-3/8	8-7/8	15-7/8	5	401.00
1/2	4-3/8	8-1/4	2	52.30	61/64	6-3/8	11	3	186.65	1-25/64	9	14-5/8	4	432.00
33/64	4-5/8	8-1/2	2	63.95	31/32	6-3/8	11	3	176.65	1-13/32	9	14-5/8	4	455.00
17/32	4-5/8	8-1/2	2	59.40	63/64	6-3/8	11	3	181.53	1-27/64	9-1/8	14-3/4	4	514.28
35/64	4-7/8	8-3/4	2	66.90	1	6-3/8	11	3	168.56	1-7/16	9-1/8	14-3/4	4*	474.01
9/16	4-7/8	8-3/4	2	62.12	1-1/64	6-1/2	12-1/8	4	245.41	1-7/16	9-1/8	16-1/8	5	474.01
37/64	4-7/8	8-3/4	2	71.00	1-1/32	6-1/2	12-1/8	4	226.20	1-29/64	9-1/4	14-7/8	4	519.00
19/32	4-7/8	8-3/4	2	69.09	1-3/64	6-5/8	12-1/4	4	223.11	1-15/32	9-1/4	14-7/8	4	509.08
39/64	4-7/8	8-3/4	2	78.25	1-1/16	6-5/8	12-1/4	4	215.95	1-31/64	9-3/8	15	4	552.20
5/8	4-7/8	8-3/4	2	70.67	1-5/64	6-7/8	12-1/2	4	244.18	1-1/2	9-3/8	15	4*	509.00
41/64	5-1/8	9-3/4	3	89.50	1-3/32	6-7/8	12-1/2	4	247.33	1-1/2	9-3/8	16-3/8	5	509.00
21/32	5-1/8	9-3/4	3	80.86	1-7/64	7-1/8	12-3/4	4	261.26	1-5/8	10	17	5	599.00
43/64	5-3/8	10	3	95.61	1-1/8	7-1/8	12-3/4	4	236.35	1-3/4	10-1/8	17-1/8	5	750.00
11/16	5-3/8	10	3	86.40	1-9/64	7-1/4	12-7/8	4	304.51	1-13/16	10-1/8	17-1/8	5	810.00
45/64	5-5/8	10-1/4	3	104.28	1-5/32	7-1/4	12-7/8	4	280.66	2	10-3/8	17-3/8	5	915.00

* Shank smaller than standard

HIGH SPEED STEEL

TITANIUM NITRIDE COATED TAPER SHANK DRILLS

▶ LIST NO. 200T — 118° POINT



Size	Flute Length	Overall Length	Morse Taper No.	Price Each
5/16	3-1/8	6-3/8	1	44.98
3/8	3-1/2	6-3/4	1	46.99
7/16	3-7/8	7-1/4	1	51.25
1/2	4-3/8	8-1/4	2	60.50
33/64	4-5/8	8-1/2	2	72.25
17/32	4-5/8	8-1/2	2	66.99
9/16	4-7/8	8-3/4	2	74.25
19/32	4-7/8	8-3/4	2	79.95
5/8	4-7/8	8-3/4	2	81.00
21/32	5-1/8	9	2	90.00
11/16	5-3/8	9-1/4	2	93.00

Size	Flute Length	Overall Length	Morse Taper No.	Price Each
23/32	5-5/8	9-1/2	2	100.00
3/4	5-7/8	9-3/4	2	109.00
25/32	6	9-7/8	2	130.00
13/16	6-1/8	10-3/4	3	136.00
27/32	6-1/8	10-3/4	3	146.00
7/8	6-1/8	10-3/4	3	150.00
29/32	6-1/8	10-3/4	3	160.00
15/16	6-1/8	10-3/4	3	152.00
31/32	6-3/8	11	3	165.00
63/64	6-3/8	11	3	182.00
1	6-3/8	11	3	168.00

Size	Flute Length	Overall Length	Morse Taper No.	Price Each
1-1/32	6-1/2	11-1/8	3	185.00
1-1/16	6-5/8	11-1/4	3	192.00
1-3/32	6-7/8	12-1/2	4	228.00
1-1/8	7-1/8	12-3/4	4	237.00
1-5/32	7-1/4	12-7/8	4	250.00
1-3/16	7-3/8	13	4	260.00
1-7/32	7-1/2	13-1/8	4	280.00
1-1/4	7-7/8	13-1/2	4	290.00
1-5/16	8-5/8	14-1/4	4	366.00
1-3/8	8-7/8	14-1/2	4	390.00
1-1/2	9-3/8	15	4	450.00



HIGH SPEED STEEL

OIL HOLE DRILLS

● TAPER SHANK — STANDARD LENGTH, 118° NOTCHED POINT LIST NO. 299



Oil Hole Drills feature coolant passages throughout the length of the body. These allow a coolant (air, oil or vapor mist) to reach the cutting edges. The resulting flow cools and lubricates the cutting edges and also aids in the extraction of chips.

Size	Dec. Equiv.	Flute Length	Overall Length	Morse Taper No.	Price Each
3/8	.3750	3-1/2	7-5/8	2	298.35
25/64	.3906	3-5/8	8	2	298.35
13/32	.4062	3-5/8	8	2	298.35
27/64	.4219	3-7/8	8-1/8	2	298.35
7/16	.4375	3-7/8	8-3/8	2	298.35
29/64	.4531	4-1/8	8-3/4	2	298.35
15/32	.4688	4-1/8	8-3/4	3	279.65
31/64	.4844	4-3/8	9	3	279.65
1/2	.5000	4-3/8	9	3	279.65
33/64	.5156	4-5/8	9-1/4	3	279.65
17/32	.5312	4-5/8	9-1/4	3	279.65
35/64	.5469	4-7/8	9-1/2	3	279.65
9/16	.5625	4-7/8	9-1/2	3	250.24
37/64	.5781	4-7/8	9-1/2	3	279.65
19/32	.5938	4-7/8	9-1/2	3	250.24
39/64	.6094	4-7/8	9-1/2	3	250.24
5/8	.6250	4-7/8	9-1/2	3	250.24
41/64	.6406	5-1/8	9-3/4	3	250.24
21/32	.6562	5-1/8	9-3/4	3	250.64
43/64	.6719	5-3/8	10	3	254.14
11/16	.6875	5-3/8	10	3	254.14
45/64	.7031	5-5/8	10-1/4	3	257.64
23/32	.7188	5-5/8	10-1/4	3	257.64
47/64	.7344	5-7/8	10-1/2	3	257.64
3/4	.7500	5-7/8	10-1/2	3	257.64
49/64	.7656	6	10-5/8	3	260.16
25/32	.7812	6	10-5/8	3	260.16
51/64	.7969	6-1/8	10-3/4	3	260.16
13/16	.8125	6-1/8	10-3/4	3	260.16
53/64	.8281	6-1/8	10-3/4	3	283.11
27/32	.8438	6-1/8	10-3/4	3	283.11
55/64	.8594	6-1/8	10-3/4	3	283.11
7/8	.8750	6-1/8	10-3/4	3	283.11
57/64	.8906	6-1/8	10-3/4	3	283.96
29/32	.9062	6-1/8	10-3/4	3	283.96
59/64	.9219	6-1/8	10-3/4	3	283.96
15/16	.9375	6-1/8	10-3/4	3	283.96
61/64	.9531	6-3/8	11	3	334.82
31/32	.9688	6-3/8	11	3	334.82

Size	Dec. Equiv.	Flute Length	Overall Length	Morse Taper No.	Price Each
63/64	.9844	6-3/8	11	3	334.82
1	1.0000	6-3/8	11	3	334.82
1-1/64	1.0156	6-1/2	11-1/8	3	362.70
1-1/32	1.0312	6-1/2	11-1/8	3	362.70
1-3/64	1.0469	6-5/8	11-1/4	3	362.70
1-1/16	1.0625	6-5/8	11-1/4	3	362.70
1-1/16	1.0625	6-5/8	12-1/4	4*	362.70
1-5/64	1.0781	6-7/8	12-1/2	4	428.43
1-3/32	1.0938	6-7/8	12-1/2	4	428.43
1-7/64	1.1094	7-1/8	12-3/4	4	468.61
1-1/8	1.1250	7-1/8	12-3/4	4	468.61
1-9/64	1.1406	7-1/4	12-7/8	4	468.61
1-5/32	1.1562	7-1/4	12-7/8	4	468.61
1-11/64	1.1719	7-3/8	13	4	471.50
1-3/16	1.1875	7-3/8	13	4	471.50
1-13/64	1.2031	7-1/2	13-1/8	4	536.54
1-7/32	1.2188	7-1/2	13-1/8	4	536.54
1-15/64	1.2344	7-7/8	13-1/2	4	536.54
1-1/4	1.2500	7-7/8	13-1/2	4	536.54
1-17/64	1.2656	8-1/2	14-1/8	4	652.20
1-9/32	1.2812	8-1/2	14-1/8	4	652.20
1-19/64	1.2969	8-5/8	14-1/4	4	701.69
1-5/16	1.3125	8-5/8	14-1/4	4	701.69
1-21/64	1.3281	8-3/4	14-3/8	4	701.69
1-11/32	1.3438	8-3/4	14-3/8	4	701.69
1-23/64	1.3594	8-7/8	14-1/2	4	776.71
1-3/8	1.3750	8-7/8	14-1/2	4	776.71
1-13/32	1.4062	9	14-5/8	4	776.71
1-7/16	1.4375	9-1/8	14-3/4	4	776.71
1-15/32	1.4688	9-1/4	14-7/8	4	810.79
1-1/2	1.5000	9-3/8	15	4	810.79
1-9/16	1.5625	9-5/8	15-1/4	4	849.35
1-5/8	1.6250	10	15-5/8	4	913.47
1-11/16	1.6875	10-1/8	15-3/4	4	1073.73
1-3/4	1.7500	10-1/8	16	4	1105.78
1-13/16	1.8125	10-1/8	17-1/8	5	1153.83
1-7/8	1.8750	10-3/8	17-3/8	5	1217.96
1-15/16	1.9375	10-3/8	17-3/8	5	1290.06
2	2.0000	10-3/8	17-3/8	5	1322.12

*Shank larger than Standard.

● TAPER SHANK — EXTRA LENGTH, 118° NOTCHED POINT



Size	Dec. Equiv.	Morse Taper No.	Price Each		
			10-1/2" OAL 6" Flute List No. 295	12-1/2" OAL 8" Flute List No. 296	14-1/2" OAL 10" Flute List No. 297
31/64	.4844	3	306.95	—	—
1/2	.5000	3	306.95	333.68	397.02
33/64	.5156	3	306.95	333.68	397.02
17/32	.5312	3	306.95	333.68	397.02
9/16	.5625	3	—	333.68	397.02
19/32	.5938	3	—	333.68	397.02
5/8	.6250	3	—	333.68	397.02
41/64	.6406	3	—	333.68	397.02
21/32	.6562	3	—	333.68	397.02
11/16	.6875	3	—	333.68	397.02
23/32	.7188	3	—	333.68	397.02
47/64	.7344	3	—	333.68	397.02
3/4	.7500	3	—	333.68	397.02
49/64	.7656	3	—	350.32	412.67

Size	Dec. Equiv.	Morse Taper No.	Price Each		
			10-1/2" OAL 6" Flute List No. 295	12-1/2" OAL 8" Flute List No. 296	14-1/2" OAL 10" Flute List No. 297
25/32	.7812	3	—	350.38	412.00
13/16	.8125	3	—	350.38	412.00
27/32	.8438	3	—	359.32	423.80
7/8	.8750	3	—	363.90	423.80
29/32	.9062	3	—	363.90	431.70
15/16	.9375	3	—	363.90	431.70
31/32	.9688	3	—	383.24	448.03
63/64	.9844	3	—	416.62	485.16
1	1.0000	3	—	416.62	485.16
1-1/32	1.0312	3	—	431.81	501.64
1-1/16	1.0625	3	—	—	501.64
1-1/8*	1.1250	4	—	—	629.20
1-3/16*	1.1875	4	—	—	674.96
1-1/4*	1.2500	4	—	—	748.59

*15-1/2 Overall

TAPER SHANK DRILL COOLANT ENTRY POINTS

TAPER	L	H	U
#2 M.T.S.	2-3/16	5/32	3/8
#3 M.T.S.	2-27/32	5/32	1/2
#4 M.T.S.	3-5/8	7/32	5/8
#5 M.T.S.	4-3/4	9/32	3/4

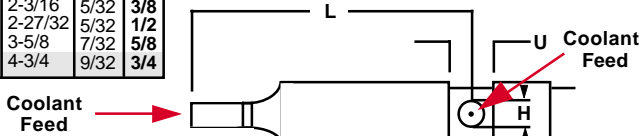

COOLANT INDUCER SOCKET

◆ LIST NO. 299H

For use with Taper Shank Oil Hole Drills

Morse Taper Hole & Shank Size	Overall Length	Price Each
2	6-7/8	110.00
3	8-1/2	134.50
4	10-1/2	299.00
5	13-3/4	575.00



OIL HOLE DRILLS

STRAIGHT SHANK



- LIST NO. 499 — 118° NOTCHED POINT
- LIST NO. 499SL — 118° NOTCHED POINT, SLOW SPIRAL

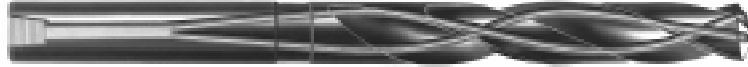

These drills are designed with oil holes the length of the land section of the drill to deliver a high pressure oil flow to the cutting edges. The resulting coolant flow flushes chips out of the hole to reduce heat and chip packing problems common to deep hole drilling applications. Surface speeds may be increased 30% or more over standard drill styles.

Size	Dec. Equiv.	Approx. Flute Length	Overall Length	Price Each	
				List No. 499	List No. 499SL
15/64	.2344	3-3/8	5-3/4	186.49	186.49
1/4	.2500	3-3/4	6-1/8	186.49	186.49
9/32	.2812	4	6-3/8	186.49	186.49
19/64	.2969	4	6-3/8	186.49	186.49
5/16	.3125	4	6-3/8	186.49	186.49
21/64	.3281	4-1/8	6-1/2	186.49	—
11/32	.3438	4-1/8	6-1/2	186.49	—
23/64	.3594	4-1/4	6-3/4	186.49	—
3/8	.3750	4-1/4	6-3/4	185.63	185.63
25/64	.3906	4-3/8	7	189.10	189.10
13/32	.4062	4-3/8	7	189.10	189.10
27/64	.4219	4-5/8	7-1/4	196.02	196.02
7/16	.4375	4-5/8	7-1/4	196.02	196.02
29/64	.4531	4-7/8	7-1/2	200.14	200.14
15/32	.4688	4-7/8	7-1/2	200.14	200.14
31/64	.4844	5	7-3/4	202.68	202.68
1/2	.5000	5	7-3/4	202.68	202.68
33/64	.5156	5-1/4	8	205.67	205.67
17/32	.5312	5-1/4	8	205.67	205.67
35/64	.5469	5-3/8	8-1/4	210.49	210.49
9/16	.5625	5-3/8	8-1/4	210.49	210.49
37/64	.5781	5-5/8	8-1/2	212.85	212.85
19/32	.5938	5-5/8	8-1/2	212.85	212.85
39/64	.6094	5-3/4	8-3/4	223.14	223.14
5/8	.6250	5-3/4	8-3/4	223.14	223.14
41/64	.6406	5-7/8	9	223.14	223.14
21/32	.6562	5-7/8	9	223.14	223.14
43/64	.6719	6	9-1/4	228.20	228.20
11/16	.6875	6	9-1/4	228.20	228.20
45/64	.7031	6-3/16	9-1/2	234.14	234.14
23/32	.7188	6-3/16	9-1/2	234.14	234.14
47/64	.7344	6-3/8	9-3/4	250.34	250.34
3/4	.7500	6-3/8	9-3/4	250.34	250.34
49/64	.7656	6-1/2	9-7/8	254.63	254.63
25/32	.7812	6-1/2	9-7/8	254.63	254.63
51/64	.7969	6-5/8	10	260.60	260.60
13/16	.8125	6-5/8	10	260.60	260.60
53/64	.8281	6-3/4	10-1/4	265.75	265.75
27/32	.8438	6-3/4	10-1/4	265.75	265.75
55/64	.8594	7	10-1/2	287.70	287.70
7/8	.8750	7	10-1/2	287.70	287.70
57/64	.8906	7	10-5/8	308.24	308.24
29/32	.9062	7	10-5/8	308.24	308.24

Size	Dec. Equiv.	Approx. Flute Length	Overall Length	Price Each	
				List No. 499	List No. 499SL
59/64	.9219	7	10-3/4	329.55	329.55
15/16	.9375	7	10-3/4	329.55	329.55
61/64	.9531	7-1/8	10-7/8	345.66	345.66
31/32	.9688	7-1/8	10-7/8	345.66	345.66
63/64	.9844	7-3/16	11	362.80	362.80
1	1.0000	7-3/16	11	362.80	362.80
1-1/64	1.0156	7-5/16	11-1/8	383.12	—
1-1/32	1.0312	7-5/16	11-1/8	383.12	—
1-3/64	1.0469	7-3/8	11-1/4	398.62	—
1-1/16	1.0625	7-3/8	11-1/4	398.62	398.62
1-5/64	1.0781	7-5/8	11-1/2	414.72	—
1-3/32	1.0938	7-5/8	11-1/2	414.72	—
1-7/64	1.1094	7-7/8	11-3/4	435.91	—
1-1/8	1.1250	7-7/8	11-3/4	435.91	435.91
1-9/64	1.1406	8	11-7/8	457.29	—
1-5/32	1.1562	8	11-7/8	457.29	—
1-11/64	1.1719	8-1/8	12	478.60	—
1-3/16	1.1875	8-1/8	12	478.60	478.60
1-13/64	1.2031	8-1/8	12-1/8	499.82	—
1-7/32	1.2188	8-1/8	12-1/8	499.82	—
1-15/64	1.2344	8-1/2	12-1/2	520.31	—
1-1/4	1.2500	8-1/2	12-1/2	520.31	520.31
1-17/64	1.2656	9-1/4	14-1/8	553.80	—
1-9/32	1.2812	9-1/4	14-1/8	553.80	—
1-19/64	1.2969	9-1/4	14-1/4	577.31	—
1-5/16	1.3125	9-1/4	14-1/4	577.31	577.31
1-21/64	1.3281	9-1/2	14-3/8	614.50	—
1-11/32	1.3438	9-1/2	14-3/8	614.50	—
1-23/64	1.3594	9-1/2	14-1/2	648.09	—
1-3/8	1.3750	9-1/2	14-1/2	648.09	648.09
1-13/32	1.4062	9-1/2	14-5/8	725.51	—
1-7/16	1.4375	9-1/8	14-3/4	725.51	725.51
1-15/32	1.4688	9-1/8	14-7/8	785.02	—
1-1/2	1.5000	9-5/8	15	785.02	785.02
1-9/16	1.5625	9-5/8	15-1/4	870.22	—
1-5/8	1.6250	9-7/8	15-5/8	941.85	—
1-11/16	1.6875	10	15-3/4	1069.90	—
1-3/4	1.7500	10-1/2	16-1/4	1130.22	—
1-13/16	1.8125	10-1/2	16-1/4	1139.45	—
1-7/8	1.8750	10-3/4	16-1/2	1253.07	—
1-15/16	1.9375	10-3/4	16-5/8	1345.76	—
2	2.0000	10-3/4	16-5/8	1413.36	—

Specials can be made to print. Please inquire.

STRAIGHT SHANK — LONG LENGTH

- LIST NO. 499X

Size	Dec. Equiv.	Approx. Flute Length	Overall Length	Price Each
13/64	.2031	4-3/4	7-1/8	275.00
7/32	.2188	4-3/4	7-1/8	289.70
15/64	.2344	5-1/8	7-1/2	289.70
1/4	.2500	5-1/2	7-1/2	338.00
17/64	.2656	5-1/2	7-7/8	338.00
9/32	.2812	5-1/2	7-7/8	338.00
19/64	.2969	5-7/8	8-1/4	338.00
5/16	.3125	5-7/8	8-1/4	338.00

Size	Dec. Equiv.	Approx. Flute Length	Overall Length	Price Each
21/64	.3281	6-1/4	8-5/8	345.00
11/32	.3438	6-1/4	8-5/8	345.00
23/64	.3594	6-3/8	8-7/8	345.00
3/8	.3750	6-3/8	8-7/8	337.40
7/16	.4375	7	9-5/8	356.20
31/64	.4844	7-1/2	10-1/4	368.33
1/2	.5000	7-1/2	10-1/4	368.33



HIGH SPEED STEEL

CORE DRILLS

STRAIGHT SHANK



Used to enlarge and straighten cored or drilled holes. Because of their rigidity, these tools generate closer tolerance holes and better finish than standard drills.

They may be used to enlarge holes as small as 60% of the tool diameter.

► LIST NO. 421 — THREE FLUTE

Size	Dec. Equiv.	Flute Length	Overall Length	Price Each
1/4	.2500	3-3/4	6-1/8	35.69
17/64	.2656	3-7/8	6-1/4	38.12
9/32	.2812	3-7/8	6-1/4	37.72
5/16	.3125	4	6-3/8	38.30
11/32	.3438	4-1/8	6-1/2	40.85
23/64	.3594	4-1/4	6-3/4	44.90
3/8	.3750	4-1/4	6-3/4	42.00
13/32	.4062	4-3/8	7	48.20
7/16	.4375	4-5/8	7-1/4	46.15
15/32	.4688	4-3/4	7-1/2	54.00
31/64	.4844	4-3/4	7-3/4	60.22
1/2	.5000	4-3/4	7-3/4	54.70
17/32	.5312	4-3/4	8	65.45
9/16	.5625	4-7/8	8-1/4	64.75
19/32	.5938	4-7/8	8-3/4	74.30

Size	Dec. Equiv.	Flute Length	Overall Length	Price Each
5/8	.6250	4-7/8	8-3/4	79.80
21/32	.6562	5-1/8	9	81.50
11/16	.6875	5-3/8	9-1/4	88.78
23/32	.7188	5-5/8	9-1/2	97.50
3/4	.7500	5-7/8	9-3/4	100.70
25/32	.7812	6	9-7/8	109.76
7/8	.8750	6-1/8	10	119.64
29/32	.9062	6-1/8	10	130.41
31/32	.9688	6-3/8	11	137.50
1-7/16	1.4375	9-1/8	14-3/4	142.15
1-9/16	1.5625	9-5/8	15-1/4	520.00
1-5/8	1.6250	9-7/8	15-5/8	543.75
1-13/16	1.8125	10-1/2	16-1/4	677.60
1-27/32	1.8438	10-3/4	16-1/2	725.58

Additional 64th sizes available on request.

STRAIGHT SHANK



► LIST NO. 422 — FOUR FLUTE

Size	Dec. Equiv.	Flute Length	Overall Length	Price Each
15/64	.2344	3-3/4	6-1/8	35.67
1/4	.2500	3-3/4	6-1/8	34.64
17/64	.2656	3-7/8	6-1/4	37.80
9/32	.2812	3-7/8	6-1/4	36.64
5/16	.3125	4	6-3/8	37.20
21/64	.3281	4-1/8	6-1/2	44.50
11/32	.3438	4-1/8	6-1/2	39.75
23/64	.3594	4-1/4	6-3/4	46.00
3/8	.3750	4-1/4	6-3/4	40.90
13/32	.4062	4-3/8	7	44.90
27/64	.4219	4-5/8	7-1/4	48.80
7/16	.4375	4-5/8	7-1/4	44.90
29/64	.4531	4-3/4	7-1/2	52.28
15/32	.4688	4-3/4	7-1/2	50.17
1/2	.5000	4-3/4	7-3/4	51.25
33/64	.5156	4-3/4	8	57.29
17/32	.5312	4-3/4	8	53.70
9/16*	.5625	4-7/8	8-1/4	56.50
19/32	.5938	4-7/8	8-3/4	67.95
5/8	.6250	4-7/8	8-3/4	71.95
41/64	.6406	5-1/8	9	81.40
21/32	.6562	5-1/8	9	77.00
11/16	.6875	5-3/8	9-1/4	82.50
23/32	.7188	5-5/8	9-1/2	81.25
3/4	.7500	5-7/8	9-3/4	86.75
49/64	.7656	6	9-7/8	109.50
25/32	.7812	6	9-7/8	103.50
13/16	.8125	6-1/8	10	117.75
27/32	.8438	6-1/8	10	122.87
7/8	.8750	6-1/8	10	117.50
57/64	.8906	6-1/8	10	130.40

Size	Dec. Equiv.	Flute Length	Overall Length	Price Each
29/32	.9062	6-1/8	10	125.00
15/16	.9375	6-1/8	10-3/4	138.90
31/32	.9688	6-3/8	11	155.50
1	1.0000	6-3/8	11	148.60
1-1/32	1.0312	6-1/2	11-1/8	224.90
1-1/16	1.0625	6-5/8	11-1/4	227.50
1-3/32	1.0938	6-7/8	11-1/2	230.44
1-1/8	1.1250	7-1/8	11-3/4	235.70
1-9/64	1.1406	7-1/4	11-7/8	240.55
1-5/32	1.1562	7-1/4	11-7/8	248.96
1-3/16	1.1875	7-3/8	12	258.70
1-7/32	1.2188	7-1/2	12-1/8	268.44
1-1/4	1.2500	7-7/8	12-1/2	277.50
1-9/32	1.2812	8-1/2	14-1/8	322.50
1-5/16	1.3125	8-5/8	14-1/4	340.60
1-11/32	1.3438	8-3/4	14-3/8	350.70
1-3/8	1.3750	8-7/8	14-1/2	360.22
1-13/32	1.4062	9	14-5/8	368.50
1-7/16	1.4375	9-1/8	14-3/4	384.00
1-15/32	1.4688	9-1/4	14-7/8	399.60
1-1/2	1.5000	9-3/8	15	420.50
1-9/16	1.5625	9-5/8	15-1/4	493.16
1-5/8	1.6250	9-7/8	15-5/8	547.50
1-11/16	1.6875	10-1/8	16	630.00
1-3/4	1.7500	10-1/2	16-1/4	660.11
1-49/64	1.7656	10-1/2	16-1/4	730.00
1-13/16	1.1875	10-1/2	16-1/4	722.00
1-7/8	1.8750	10-5/8	16-1/4	715.45
1-15/16	1.9375	10-3/4	16-5/8	760.20
2	2.0000	10-3/4	17-1/4	799.25

Additional 64th sizes available on request.

* 9/16 with 1/2" shank in stock \$56.50 each.

MACHINE TOOL ACCESSORIES

● MORSE TAPER SLEEVES

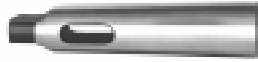

For adapting Morse Taper shank tools to machine spindles having large Morse Taper holes. Available with hardened tang or hardened and ground throughout.

● MORSE TAPER EXTENSION SOCKETS



Used to increase or decrease the Morse Taper spindle capacity or to increase Morse Taper spindle projection.

SLEEVES AND SOCKETS										
Size	Morse Taper No.		Morse Taper Sleeves				Morse Taper Extension Socket			
	Internal	External	Overall Length	Hard Tang Only		Hard & Ground		Overall Length	Tool No.	Price Each
				Tool No.	Price Ea.	Tool No.	Price Ea.			
1 to 1	1	1	—	—	—	—	—	6-1/4	ES11	17.33
1 to 2	1	2	3-9/16	TS12	9.00	TSH12	14.65	6-1/4	ES12	17.33
1 to 3	1	3	3-15/16	TS13	14.11	TSH13	19.24	6-7/8	ES13	21.11
1 to 4	1	4	4-7/8	TS14	21.83	TSH14	31.00	7-1/2	ES14	25.27
1 to 5	1	5	6-1/8	TS15	27.50	TSH15	47.25	9-1/16	ES15	36.75
2 to 1	2	1	—	—	—	—	—	6-1/4	ES21	20.18
2 to 2	2	2	—	—	—	—	—	6-7/8	ES22	20.22
2 to 3	2	3	4-7/16	TS23	10.19	TSH23	19.59	7-5/8	ES23	20.22
2 to 4	2	4	4-7/8	TS24	18.89	TSH24	33.36	8-1/2	ES24	29.02
2 to 5	2	5	6-1/8	TS25	38.11	TSH25	47.25	9-3/4	ES25	36.75
3 to 1	3	1	—	—	—	—	—	7-1/4	ES31	25.12
3 to 2	3	2	—	—	—	—	—	7-3/4	ES32	25.13
3 to 3	3	3	—	—	—	—	—	8-1/2	ES33	25.13
3 to 4	3	4	5-3/8	TS34	15.90	TSH34	33.38	9-1/2	ES34	25.13
3 to 5	3	5	6-1/8	TS35	27.50	TSH35	47.22	10-1/2	ES35	39.30
4 to 2	4	2	—	—	—	—	—	8-1/2	ES42	38.49
4 to 3	4	3	—	—	—	—	—	9-1/2	ES43	38.49
4 to 4	4	4	—	—	—	—	—	10-1/2	ES44	38.49
4 to 5	4	5	6-5/8	TS45	36.25	TSH45	47.22	11-7/8	ES45	48.05
4 to 6	4	6	8-5/8	TS46	69.09	TSH46	135.10	14	ES46	109.59
5 to 3	5	3	—	—	—	—	—	10-1/2	ES53	85.85
5 to 4	5	4	—	—	—	—	—	11-3/8	ES54	85.85
5 to 5	5	5	—	—	—	—	—	13-3/4	ES55	89.92
5 to 6	5	6	8-5/8	TS56	74.90	TSH56	146.55	15-3/8	ES56	109.59

● DRILL DRIFTS OR CENTER KEYS

Drop Forged and Hardened



For removing taper shank tools from sleeves or spindles.

● SOLID SOCKETS WITH MORSE TAPER HOLES

Hardened and Ground Throughout



For adapting tools with Morse Taper shanks to machines with straight holes.

DRILL DRIFTS			
Size	For Use With Taper Number	Tool No.	Price Each
1	1	DD1	4.56
2	2	DD2	5.51
3	3	DD3	6.09
4	4, 5, 6	DD4	9.42

DRILL DRIFT SET
SET NO. DD14

Contains 1 piece of each: 1 thru 4
SET PRICE — \$24.95

SOLID SOCKETS									
Size	Inside Morse Taper No.	Outside Dia.	Tool No.	Price Each	Size	Inside Morse Taper No.	Outside Dia.	Tool No.	Price Each
1	1	1	SS11	20.92	10	3	1-1/2	SS103	34.58
2	1	1-1/4	SS21	25.65	11	3	1-3/4	SS113	37.80
3	1	1-1/2	SS31	23.98	12	3	2	SS123	41.20
4	2	1	SS42	23.98	13	4	1-1/2	SS134	41.20
5	2	1-1/4	SS52	26.29	14	4	1-3/4	SS144	44.87
6	2	1-1/2	SS62	27.92	15	4	2	SS154	47.74
7	2	1-3/4	SS72	30.52	16	5	2-1/4	SS165	83.43
8	2	2	SS82	32.05	17	5	2-1/2	SS175	83.43
9	3	1-1/4	SS93	32.05	18	6	3-1/4	SS185	133.28

◆ MILLING MACHINE ADAPTERS



R-8 ADAPTERS FOR NATIONAL STANDARD TAPERS			
Inside Taper	Outside Taper	Tool No.	Price Each
R-8	40	R8N40	107.00
R-8	50	R8N50	128.00

R-8 ADAPTERS FOR MORSE TAPERS		
Inside Taper	Tool No.	Price Each
#2 Morse	R8M2	49.50
#3 Morse	R8M3	56.50



CARBIDE TIPPED MASONRY DRILLS

STRAIGHT SHANK



For drilling brick, stone, slate, marble, cement, concrete, carbon, asphalt, plaster and wallboard.
These drills may be used in portable electric drills, drill presses, or other fixed spindle machine tools.

- ▶ LIST NO. CT890 — REGULAR HELIX TYPE
- ▶ LIST NO. CT890F — FAST HELIX TYPE

4" OVERALL

Size	Shank Size	Price Each	
		List No. CT890	List No. CT890F
*1/8	1/8	4.99	4.99
*5/32	5/32	5.25	—
*11/64	11/64	5.25	—
3/16	3/16	5.35	5.35
7/32	7/32	5.50	—
1/4	1/4	5.60	5.60
9/32	1/4	5.75	—
5/16	1/4	5.85	5.85
3/8	1/4	6.30	6.30
7/16	1/4	7.20	7.20
1/2	1/4	7.30	—

* 3" Overall Length

- ▶ LIST NO. CT891 — REGULAR HELIX TYPE
- ▶ LIST NO. CT891F — FAST HELIX TYPE

6" OVERALL

Size	Shank Size	Price Each	
		List No. CT891	List No. CT891F
1/8	1/8	5.25	—
3/16	3/16	5.40	5.40
1/4	1/4	5.60	5.60
9/32	1/4	6.25	—
5/16	1/4	6.50	6.50
3/8	1/4	6.70	6.70
7/16	1/4	7.15	7.15
7/16	3/8	7.15	7.15
1/2	1/4	7.75	7.75
1/2	3/8	7.75	7.75
9/16	3/8	10.75	10.75

Size	Shank Size	Price Each	
		List No. CT891	List No. CT891F
9/16	1/2	10.75	10.75
5/8	1/2	12.50	12.50
11/16	1/2	13.65	13.65
3/4	1/2	14.75	14.75
7/8	1/2	18.75	18.75
1	1/2	23.00	23.00
1-1/8	1/2	33.00	—
1-1/4	1/2	43.00	—
1-3/8	1/2	58.00	—
1-1/2	1/2	59.50	—

- ▶ LIST NO. CT892 — REGULAR HELIX TYPE
- ▶ LIST NO. CT892F — FAST HELIX TYPE

12" OVERALL

Size	Shank Size	Price Each	
		List No. CT892	List No. CT892F
1/8	1/8	12.40	—
3/16	3/16	12.75	—
1/4	1/4	12.95	12.95
5/16	1/4	13.75	13.75
3/8	1/4	15.50	15.50
7/16	3/8	18.50	18.50
1/2	1/4	18.90	18.90
1/2	3/8	18.90	18.90
9/16	1/2	21.50	—
5/8	1/2	23.75	—
11/16	1/2	27.90	—
3/4	1/2	28.50	—
7/8	1/2	33.90	—
1	1/2	39.00	—
1-1/8	1/2	49.00	—
1-3/8	1/2	78.00	—

SETS

MASONRY DRILL SET SET NO. CT890S

4 Piece Set
Contains 1 piece each of:
1/4, 5/16, 3/8, 1/2, by 4" OAL
Regular Spiral
Supplied in Polytube
SET PRICE — \$25.00

HS STEEL 1/4 SHANK DRILL AND MASONRY DRILL SET

SET NO. 304B
10 Piece Set
Contains 1 piece each of HS.
1/4 Shank Drill:
1/4, 5/16, 3/8, 7/16, 1/2
and 1/4 Shank Carbide Tipped
Masonry Drills:
1/4, 5/16, 3/8, 7/16, 1/2
SET PRICE — \$85.00

- ▶ LIST NO. CT893
REGULAR HELIX TYPE

18" OVERALL

Size	Shank Size	Price Each
1/4	1/4	19.95
3/16	3/16	21.00
5/16	1/4	22.50
3/8	5/16	24.00
7/16	3/8	28.80
1/2	3/8	29.50
9/16	1/2	34.00
5/8	1/2	36.00
5/8	3/8	36.00
11/16	1/2	42.00
3/4	1/2	43.00
7/8	1/2	52.00
1	1/2	59.00
1-1/8	1/2	84.00
1-1/4	1/2	89.00
1-3/8	1/2	125.00
1-1/2	1/2	115.00

CARBIDE TIPPED

GLASS AND TILE DRILLS



- ▶ LIST NO. CT898



For drilling glass, tiles, ceramics and other hard, fragile materials without chipping or cracking the material. Liquid coolant recommended.

Size	Overall Length	Price Each
1/8	2-1/2	12.00
5/32	2-1/2	12.75
3/16	2-1/2	13.75
1/4	2-1/2	15.00
5/16	2-1/2	16.85
3/8	3	24.50
1/2	3	28.50

CARBIDE TIPPED

STANDARD "A" TAPER SHANK DRILLS



- LIST NO. CT884



Use in rotary hammer drills with "A" taper chucks or adapters.

Size	Price Each			
	4-1/2" OAL	6" OAL	9" OAL	12" OAL
3/16	8.67*	9.00	—	—
1/4	9.80*	10.20	—	15.90
5/16	10.25	11.25	—	—
3/8	10.75	12.50	13.75	17.80
7/16	12.00	14.20	—	—

Size	Price Each		
	6" OAL	9" OAL	12" OAL
1/2	14.50	16.80	22.00
9/16	—	17.85	—
5/8	17.25	22.50	29.00
3/4	22.00	27.50	34.50
7/8	—	38.85	—

* 3/16 — 3-5/8 OAL
* 1/4 — 4" OAL



CARBIDE TIPPED

HAMMER DRILLS

SDS - PLUS MASONRY DRILLS

4 SLOT SHANK
● LIST NO. CT886



The versatile Slot Drive System fits all rotary Hammer Drills that specify an SDS - PLUS shank. Positive drive slots will deliver maximum drilling torque and hammering energy for faster drilling.

SDS - MAX MASONRY DRILLS

5 SLOT SHANK
● LIST NO. CT886MX



Extra heavy duty Slot Drive System to maximize performance

Size	Aprox. Usable Length	Aprox. Overall Length	Price Each
5/32	4	6-5/8	8.20
3/16	2	4-5/8	8.43
3/16	4	6-5/8	8.64
3/16	6	8-5/8	11.56
7/32	4	6-5/8	9.72
1/4	2	4-5/8	8.80
1/4	4	6-5/8	9.58
1/4	6	8-5/8	12.00
1/4	12	14-5/8	22.80
5/16	4	6-5/8	12.50
5/16	10	12-5/8	22.50
3/8	4	6-5/8	11.70
3/8	10	12-5/8	22.50
7/16	4	6-5/8	16.50
7/16	10	12-5/8	22.80
7/16	16	18-5/8	33.00
1/2	4	6-5/8	14.40
1/2	10	12-5/8	27.50

Size	Aprox. Usable Length	Aprox. Overall Length	Price Each
1/2	14	18-5/8	32.00
9/16	4	6-3/4	21.50
9/16	10	12-3/4	29.00
9/16	16	18-3/4	39.00
5/8	4	6-3/4	24.00
5/8	10	12-3/4	36.00
5/8	15	18-3/4	49.00
11/16	4	6-3/4	34.00
3/4	4	6-3/4	32.00
3/4	6	9-3/4	40.80
3/4	10	12-3/4	46.80
3/4	14	18-3/4	58.00
7/8	4	6-3/4	34.00
7/8	10	12-3/4	59.00
7/8	14	18-3/4	69.00
1	10	13-3/4	62.40
1	14	18-3/4	78.00

Size	Aprox. Usable Length	Aprox. Overall Length	Price Each
3/8	7	13	64.95
1/2	7	13	66.00
1/2	16	21	81.90
9/16	7	13	74.80
9/16	16	21	99.50
5/8	7	13	79.50
5/8	16	21	101.50
5/8	31	36	169.00
3/4	7	13	79.75
3/4	16	21	103.00
3/4	31	36	189.50
7/8	8	13	92.50
7/8	16	21	127.50
1	8	13	99.00
1	16	21	121.00
1	31	36	217.50
1-1/8	16	21	158.00
1-1/4	16	21	169.00
1-1/2	16	21	242.00

SPLINE BITS

● LIST NO. CT887



Heavy duty spline shanks to fit popular Hammer Drills.

Size	Price Each		
	12" OAL	18" OAL	24" OAL
3/8	39.90	47.50	—
1/2	42.50	48.75	57.75
9/16	44.75	51.25	—
5/8	47.00	53.50	61.20
11/16	50.00	—	—
3/4	52.00	56.80	62.75

Size	Price Each		
	12" OAL	18" OAL	24" OAL
7/8	55.00	61.25	68.00
1	62.50	70.00	78.75
1-1/8	—	79.00	92.00
1-1/4	—	93.75	101.85
1-1/2	—	122.50	136.50

CARBIDE TIPPED

IMPACT HAMMER DRILLS

● LIST NO. CT880 — PERCUSSION TYPE DRILLS



For use in Hammer Drills equipped with 3-Jawed Jacobs Type Chuck.

Size	Shank Diameter	Overall Length	Price Each
1/8	1/8	3	3.77
1/8	1/8	6	5.30
5/32	9/64	3	5.30
11/64	9/64	3	5.30
3/16	3/16	3	3.77
3/16	3/16	6	4.20
3/16	3/16	8	5.95
7/32	7/32	4	4.20
1/4	1/4	4	3.92
1/4	1/4	6	4.95
1/4	1/4	13	12.50
1/4	1/4	18	14.50
9/32	1/4	4	4.95
5/16	1/4	4	4.62

Size	Shank Diameter	Overall Length	Price Each
5/16	1/4	6	5.50
5/16	1/4	13	11.50
3/8	1/4	4	5.77
3/8	1/4	6	6.40
3/8	3/8	13	12.00
3/8	3/8	20	15.75
3/8	3/8	24	22.00
7/16	1/4	6	7.50
1/2	3/8	6	7.80
1/2	3/8	13	14.50
9/16	1/2	6	9.40
9/16	3/8	13	16.80
5/8	1/2	6	10.50
5/8	1/2	13	17.85

Size	Shank Diameter	Overall Length	Price Each
5/8	1/2	18	22.00
11/16	1/2	6	13.00
3/4	1/2	6	14.00
3/4	1/2	13	21.00
7/8	1/2	6	17.35
7/8	1/2	13	23.10
7/8	1/2	18	30.45
1	1/2	6	21.00
1	1/2	13	28.50
1	1/2	18	38.50
1-1/8	1/2	13	31.50
1-1/8	1/2	18	38.85
1-1/4	1/2	6	32.50
1-1/2	1/2	6	42.00

BRAD AND SPUR POINT DRILLS

Please order in package quantity.



● LIST NO. 311B



Brad and Spur Point Drills are used primarily in wood. The Brad Point tip ensures an easy and accurate start while the spurs cut a clean, smooth hole, especially at breakthrough.

Size	Dec. Equiv.	Shank Diameter	Flute Length	Overall Length	Pkg. Qty.	Price Each
1/8	.1250	1/8	1-5/8	2-3/4	12	4.30
3/16	.1875	3/16	2-5/16	3-1/2	12	4.95
1/4	.2500	1/4	2-3/4	4	12	5.90
5/16	.3125	1/4	2-1/2	3-13/16	6	9.40
5/16	.3125	5/16	3-3/16	4-1/2	6	6.75
3/8	.3750	1/4	2-7/8	4-1/4	6	11.75
7/16	.4375	1/4	3-3/8	4-11/16	6	13.50
1/2	.5000	1/4	3-5/8	5-1/16	6	16.50
9/16	.5625	1/2	3	6	1	27.50
5/8	.6250	1/2	3	6	1	29.90
11/16	.6875	1/2	3	6	1	35.50
3/4	.7500	1/2	3	6	1	37.80

CARBIDE TIPPED

SILVER AND DEMING (BOWLING BALL) DRILLS

■ LIST NO. CT810 — SILVER AND DEMING BOWLING BALL — 1/2" STRAIGHT SHANK
3-7/8" Flute, 6-1/4" Overall

TAPER SHANK (BOWLING BALL) DRILLS

■ LIST NO. CT811 — TAPER SHANK BOWLING BALL — 2 MORSE TAPER SHANK
4-1/8" Flute, 7-1/2" Overall



These drills can also be used effectively in many drilling applications using bakelite composites and other similar non-metallic material.

Size	Dec. Equiv.	Price Each	
		S.S. List No. CT810	T.S. List No. CT811
7/16	.4375	17.50	32.00
1/2	.5000	17.50	32.00
9/16	.5625	19.85	34.80
5/8	.6250	22.50	36.00
21/32	.6562	23.00	38.25
11/16	.6875	24.00	38.85
23/32	.7188	25.00	40.80
3/4	.7500	25.50	44.20
25/32	.7812	26.00	45.00
13/16	.8125	26.50	46.00
27/32	.8438	28.00	47.00
7/8	.8750	29.75	48.00

Other sizes available. Please inquire.

Size	Dec. Equiv.	Price Each	
		S.S. List No. CT810	T.S. List No. CT811
29/32	.9062	31.50	50.75
15/16	.9375	33.00	51.50
61/64	.9531	34.00	55.00
31/32	.9688	35.00	56.00
63/64	.9844	36.50	57.50
1	1.0000	37.75	59.00
1-1/64	1.0156	39.50	69.00
1-1/32	1.0312	41.00	70.00
1-1/16	1.0625	42.00	71.00
1-3/32	1.0938	44.00	72.00
1-1/8	1.1250	45.50	73.00
1-1/4	1.2500	48.00	85.00

SET NO. CT810S
17 PIECE SET
Contains 1 Piece Each:
5/8" to 1-1/8" by 32nds
Supplied in wood block.
STRAIGHT SHANK
SET PRICE — \$540.00



SET NO. CT811S
TAPER SHANK
SET PRICE — \$895.00

SET NO. CT810L
23 PIECE SET
Contains 1 Piece Each:
7/16" to 1-1/8" by 32nds
also 61/64, 63/64 and 1-1/64
Supplied in wood block.
STRAIGHT SHANK
SET PRICE — \$704.85



SET NO. CT811L
TAPER SHANK
SET PRICE — \$1175.00

SOLID CARBIDE METRIC DRILLS

■ LIST NO. C800



Size mm	Dec. Equiv.	Flute Length	Overall Length	Price Each
1.50	.0591	3/4	1-1/2	13.50
2.00	.0787	7/8	1-3/4	13.75
2.50	.0984	1	2	16.35
3.00	.1181	1-1/4	2-1/4	17.70
3.50	.1378	1-3/8	2-1/2	19.50
4.00	.1575	1-3/8	2-1/2	22.98
4.50	.1772	1-5/8	2-3/4	25.55
5.00	.1969	1-3/4	3	28.90

Size mm	Dec. Equiv.	Flute Length	Overall Length	Price Each
5.50	.2165	1-3/4	3	32.44
6.00	.2362	2	3-1/4	39.49
6.50	.2559	2	3-1/4	46.20
7.00	.2756	2-1/8	3-1/2	47.79
7.50	.2953	2-3/8	3-3/4	51.10
8.00	.3150	2-3/8	3-3/4	61.96
8.50	.3346	2-1/2	4	67.64

Size mm	Dec. Equiv.	Flute Length	Overall Length	Price Each
9.00	.3543	2-1/2	4	75.00
9.50	.3740	2-3/4	4-1/4	85.90
10.00	.3937	2-7/8	4-1/2	99.34
10.50	.4134	2-7/8	4-1/2	106.01
11.00	.4331	2-7/8	4-1/2	114.97
11.50	.4528	3	4-3/4	128.10
12.00	.4724	3	4-3/4	141.91

SOLID CARBIDE SCREW MACHINE LENGTH DRILLS

■ LIST NO. C600



Size	Dec. Equiv.	Flute Length	Overall Length	Price Each
1/32	.0312	3/8	1-1/8	11.90
3/64	.0469	1/2	1-1/2	11.90
1/16	.0625	5/8	1-5/8	11.90
5/64	.0781	11/16	1-11/16	11.90
3/32	.0938	3/4	1-3/4	11.90
7/64	.1094	13/16	1-13/16	11.90
1/8	.1250	7/8	1-7/8	10.75
9/64	.1406	15/16	1-15/16	12.75
5/32	.1562	1	2-1/16	14.25
11/64	.1719	1-1/16	2-1/8	18.00
3/16	.1875	1-1/8	2-3/16	18.50

Size	Dec. Equiv.	Flute Length	Overall Length	Price Each
13/64	.2031	1-3/16	2-1/4	20.40
7/32	.2188	1-1/4	2-3/8	20.40
15/64	.2344	1-5/16	2-7/16	27.75
1/4	.2500	1-3/8	2-1/2	27.75
17/64	.2656	1-7/16	2-5/8	29.95
9/32	.2812	1-1/2	2-11/16	31.90
19/64	.2969	1-9/16	2-3/4	34.70
5/16	.3125	1-5/8	2-13/16	34.70
21/64	.3281	1-11/16	2-15/16	39.50
11/32	.3438	1-11/16	3	42.70

Size	Dec. Equiv.	Flute Length	Overall Length	Price Each
23/64	.3594	1-3/4	3-1/16	46.60
3/8	.3750	1-13/16	3-1/8	46.60
25/64	.3906	1-7/8	3-1/4	54.40
13/32	.4062	1-15/16	3-5/16	60.30
27/64	.4219	2	3-3/8	67.30
7/16	.4375	2-1/16	3-7/16	67.30
29/64	.4531	2-1/8	3-9/16	80.70
15/32	.4688	2-1/8	3-5/8	84.75
31/64	.4844	2-3/16	3-11/16	84.75
1/2	.5000	2-1/4	3-3/4	84.75

SOLID CARBIDE STRAIGHT FLUTE DRILLS

■ LIST NO. C801



Designed for drilling hardened, treated and abrasive materials. These drills penetrate most work pieces easily with minimal deflection.

Size	Dec. Equiv.	Flute Length	Overall Length	Price Each
3/64	.0469	1/2	1-1/2	8.50
1/16	.0625	5/8	1-5/8	8.80
5/64	.0781	11/16	1-11/16	9.00
3/32	.0938	3/4	1-3/4	9.50
7/64	.1094	13/16	1-13/16	10.95
1/8	.1250	7/8	1-7/8	11.25
9/64	.1406	15/16	1-15/16	13.00
5/32	.1562	1	2-1/16	14.00
11/64	.1719	1-1/16	2-1/8	17.60
3/16	.1875	1-1/8	2-3/16	18.28

Size	Dec. Equiv.	Flute Length	Overall Length	Price Each
13/64	.2031	1-3/16	2-1/4	19.78
7/32	.2188	1-1/4	2-3/8	19.78
15/64	.2344	1-5/16	2-7/16	26.79
1/4	.2500	1-3/8	2-1/2	22.60
17/64	.2656	1-7/16	2-5/8	32.00
9/32	.2812	1-1/2	2-11/16	34.40
19/64	.2969	1-9/16	2-3/4	38.09
5/16	.3125	1-5/8	2-13/16	34.40
21/64	.3281	1-11/16	2-15/16	42.08
11/32	.3438	1-11/16	3	46.80

Size	Dec. Equiv.	Flute Length	Overall Length	Price Each
23/64	.3594	1-3/4	3-1/16	52.35
3/8	.3750	1-13/16	3-1/8	42.95
25/64	.3906	1-7/8	3-1/4	59.97
13/32	.4062	1-15/16	3-5/16	66.25
27/64	.4219	2	3-3/8	72.96
7/16	.4375	2-1/16	3-7/16	68.66
29/64	.4531	2-1/8	3-9/16	88.25
15/32	.4688	2-1/8	3-5/8	92.61
31/64	.4844	2-3/16	3-11/16	92.61
1/2	.5000	2-1/4	3-3/4	84.27

SOLID CARBIDE SPADE DRILLS

■ LIST NO. C802



Designed for thin sheet metal and shallow hole drilling

Size	Dec. Equiv.	Flute Length	Overall Length	Price Each
1/16	.0625	5/16	1-1/2	8.75
3/32	.0938	3/8	1-1/2	8.75
1/8	.1250	7/16	1-1/2	7.50
5/32	.1562	15/32	2	13.90
3/16	.1875	9/16	2	13.90
1/4	.2500	11/16	2	13.90
9/32	.2812	3/4	2-1/2	18.60

Size	Dec. Equiv.	Flute Length	Overall Length	Price Each
5/16	.3125	7/8	2-1/2	18.60
11/32	.3438	15/16	2-1/2	22.77
3/8	.3750	1	2-1/2	22.77
13/32	.4062	1	2-1/2	31.70
7/16	.4375	1-1/16	2-1/2	31.70
15/32	.4688	1-3/32	2-1/2	34.00
1/2	.5000	1-1/8	3	34.00



THREADED SHANK ADAPTER DRILLS

1/4-28 THREADED SHANK – 135° SPLIT POINT

NATIONAL AEROSPACE STANDARD (NAS965)

- LIST NO. 602 — HIGH SPEED
- LIST NO. 602C — COBALT



STUB SERIES

Size	Dec. Equiv.	Flute Length	Overall Length*	Price Each	
				List No. 602	List No. 602C
58	.0420	1/4	1/2	4.60	5.00
57	.0430	5/16	1/2	4.60	5.00
55	.0520	5/16	1/2	4.60	5.00
54	.0550	5/16	1/2	4.60	5.00
53	.0595	5/16	1/2	4.60	5.10
52	.0635	5/16	1/2	4.60	5.10
50	.0700	5/16	1/2	4.60	5.10
40	.0980	5/16	1/2	3.70	4.50
1/8	.1250	5/16	1/2	3.80	4.60
30	.1285	5/16	9/16	3.90	4.70
29	.1360	5/16	9/16	3.95	4.75
28	.1405	5/16	9/16	3.95	4.75
27	.1440	5/16	9/16	4.00	4.80
5/32	.1562	5/16	9/16	4.00	4.80
21	.1590	5/16	9/16	4.00	4.80
20	.1610	5/16	9/16	4.00	4.80
19	.1660	5/16	9/16	4.00	4.80
16	.1770	5/16	9/16	4.50	5.30

Size	Dec. Equiv.	Flute Length	Overall Length*	Price Each	
				List No. 602	List No. 602C
13	.1850	5/16	9/16	4.60	5.40
3/16	.1875	5/16	9/16	4.70	5.50
12	.1890	5/16	9/16	4.75	5.55
11	.1910	5/16	9/16	4.80	5.60
10	.1935	5/16	9/16	4.80	5.60
7	.2010	5/16	5/8	—	5.70
6	.2040	5/16	5/8	4.90	5.70
5	.2055	5/16	5/8	4.90	5.70
3	.2130	5/16	5/8	4.95	5.75
7/32	.2188	5/16	5/8	5.00	5.80
15/64	.2344	5/16	5/8	—	6.30
1/4	.2500	5/16	5/8	5.50	6.50
6.40mm	.2520	5/16	5/8	5.70	6.70
F	.2570	5/16	5/8	5.75	6.80
9/32	.2812	5/16	5/8	6.50	8.20
21/64	.3281	5/16	5/8	11.25	15.00
11/32	.3438	5/16	5/8	12.50	15.20

* Not including threads

- LIST NO. 603 — HIGH SPEED
- LIST NO. 603C — COBALT



SHORT SERIES

Size	Dec. Equiv.	Flute Length	Overall Length*	Price Each	
				List No. 603	List No. 603C
60	.0400	9/16	1	4.60	—
1/16	.0625	9/16	1	4.60	—
50	.0700	9/16	1	4.60	5.00
5/64	.0781	9/16	1	4.60	—
42	.0935	9/16	1	4.60	5.00
3/32	.0938	9/16	1	4.60	—
41	.0960	9/16	1	4.20	—
40	.0980	9/16	1	3.70	4.50
39	.0995	9/16	1	3.75	4.55
38	.1015	9/16	1	3.75	4.55
36	.1065	9/16	1	3.75	4.55
7/64	.1094	9/16	1	3.75	—
35	.1100	9/16	1	3.75	4.55
33	.1130	9/16	1	3.80	4.60
31	.1200	9/16	1	3.80	—
1/8	.1250	9/16	1	3.80	4.60
30	.1285	9/16	1-1/4	3.90	4.70
29	.1360	9/16	1-1/4	3.95	4.75
28	.1405	9/16	1-1/4	3.95	4.75
9/64	.1406	9/16	1-1/4	3.95	4.75
27	.1440	9/16	1-1/4	4.00	4.80
24	.1520	9/16	1-1/4	4.00	—
5/32	.1562	9/16	1-1/4	4.00	4.80
22	.1570	9/16	1-1/4	4.00	4.80
21	.1590	9/16	1-1/4	4.00	4.80
20	.1610	9/16	1-1/4	4.00	4.80
19	.1660	9/16	1-1/4	4.10	4.90
18	.1695	9/16	1-1/4	4.50	—

Size	Dec. Equiv.	Flute Length	Overall Length*	Price Each	
				List No. 603	List No. 603C
11/64	.1719	9/16	1-1/4	4.50	5.40
17	.1730	9/16	1-1/4	4.55	5.50
16	.1770	9/16	1-1/4	4.60	5.55
13	.1850	9/16	1-1/4	4.85	5.60
3/16	.1875	9/16	1-1/4	4.90	5.85
12	.1890	9/16	1-1/4	5.00	5.85
11	.1910	9/16	1-1/4	5.00	5.85
10	.1935	9/16	1-1/4	5.00	5.85
9	.1960	9/16	1-1/4	5.10	6.00
8	.1990	9/16	1-1/4	5.15	6.05
6	.2040	9/16	1-1/4	5.20	6.10
5	.2055	9/16	1-1/4	5.25	6.15
7/32	.2188	9/16	1-1/4	5.35	6.35
2	.2210	9/16	1-1/4	5.50	—
1	.2280	9/16	1-1/4	5.50	6.40
15/64	.2344	9/16	1-1/4	5.70	6.90
B	.2380	9/16	1-1/4	6.00	7.20
D	.2460	9/16	1-1/4	6.10	7.90
1/4	.2500	9/16	1-1/4	6.20	7.90
F	.2570	9/16	1-1/4	6.50	8.00
H	.2660	9/16	1-1/4	7.00	8.10
9/32	.2812	9/16	1-1/4	7.50	9.00
O	.3160	9/16	1-1/4	14.00	—
21/64	.3281	9/16	1-1/4	12.20	16.00
11/32	.3438	9/16	1-1/4	13.10	16.10
3/8	.3750	9/16	1-1/4	13.20	16.50
1/2	.5000	9/16	1-1/4	26.00	—

* Not including threads

HIGH SPEED STEEL

AIRCRAFT TAPER ROUTER

LEFT HAND HELIX, RIGHT HAND CUT

- LIST NO. 606
- 9/16 Length of Cut, 2-3/8 OAL

Size	Price Each
1/4	2.99
5/16	5.75



COMBINED DRILLS AND COUNTERSINKS

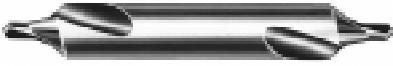

Combined drills and countersinks are used when locating an accurate center hole is required to assure the precision and quality of subsequent machining operations.

PLAIN TYPE — 60° COUNTERSINK ANGLE

- ▶ LIST NO. 585 — PREMIUM IMPORT
- LIST NO. 585U — MADE IN U.S.A
- LIST NO. 585TC — PREMIUM IMPORT TiN COATED
- LIST NO. 585UTC — MADE IN U.S.A TiN COATED

PLAIN TYPE — 82° COUNTERSINK ANGLE

- LIST NO. 582

PLAIN TYPE — 90° COUNTERSINK ANGLE

- LIST NO. 590

Size	Body Diameter	Drill Dia. and Length	Overall Length	Package Quantity	Price Each			
					Premium Import List No. 585	Made in USA List No. 585U	Premium Import TiN Coated List No. 585TC	Made in USA TiN Coated List No. 585UTC
000	1/8	.020	1-1/4	12	6.69	8.77	7.79	9.87
00	1/8	.025	1-1/4	12	6.69	8.77	7.79	9.87
0	1/8	1/32	1-1/4	12	6.69	8.77	7.79	9.87
1	1/8	3/64	1-1/4	12	5.61	6.11	7.79	7.21
2	3/16	5/64	1-7/8	12	5.61	6.41	7.79	7.51
3	1/4	7/64	2	12	5.67	6.66	7.87	8.80
4	5/16	1/8	2-1/8	12	5.83	6.86	8.03	9.06
4-1/2	3/8	9/64	2-1/2	6	7.70	9.46	9.90	11.66
5	7/16	3/16	2-3/4	6	8.69	10.87	11.46	13.64
6	1/2	7/32	3	6	13.06	16.38	15.83	19.15
7	5/8	1/4	3-1/4	1	18.94	23.68	23.65	28.39
8	3/4	5/16	3-1/2	1	26.37	32.68	34.16	40.47
9	7/8	11/32	3-5/8	1	49.50	61.89	58.68	71.07
10	1	3/8	3-3/4	1	64.69	81.23	75.29	91.83



Size	Price Each	
	82° List No. 582	90° List No. 590
1	10.20	10.20
2	10.45	10.45
3	10.80	10.80
4	11.25	11.25
5	17.15	17.15
6	25.90	25.90
7	35.50	35.50
8	50.25	50.25

LONG SERIES — 60° COUNTERSINK ANGLE

- ▶ LIST NO. 589 — PREMIUM IMPORT
- LIST NO. 589U — MADE IN U.S.A



Long Combined Drills and Countersinks are used for producing center holes where the extra length is required to access difficult to reach areas.

Size	Body Dia.	Drill Dia.	Overall Length	Price Each	
				Premium Import List No. 589	Made in USA List No. 589U
1	1/8	3/64	3	20.27	25.33
1	1/8	3/64	4	21.17	26.46
1	1/8	3/64	5	28.50	35.62
1	1/8	3/64	6	38.10	47.62
2	3/16	5/64	4	23.26	29.07
2	3/16	5/64	5	29.52	36.90
2	3/16	5/64	6	38.10	47.62
3	1/4	7/64	4	24.45	30.56
3	1/4	7/64	5	32.20	40.25
3	1/4	7/64	6	38.10	47.62
4	5/16	1/8	4	26.81	33.51
4	5/16	1/8	5	34.33	42.91
4	5/16	1/8	6	39.69	49.61
4-1/2	3/8	9/64	4	30.10	37.62
4-1/2	3/8	9/64	5	36.80	46.00
4-1/2	3/8	9/64	6	42.05	52.56
5	7/16	3/16	4	34.50	43.12
5	7/16	3/16	5	39.36	49.20
5	7/16	3/16	6	44.15	55.18
6	1/2	7/32	5	41.45	51.81
6	1/2	7/32	6	50.08	62.60
6	1/2	7/32	7	56.59	67.91
7	5/8	1/4	6	92.48	115.60
8	3/4	5/16	6	100.88	126.10

BELL TYPE — 60° COUNTERSINK ANGLE

- ▶ LIST NO. 587



Size	Body Dia.	Drill Dia. and Length	Overall Length	Bell Dia.	Pkg. Qty.	Price Each
11	1/8	3/64	1-1/4	.1000	12	8.50
12	3/16	1/16	1-7/8	.1500	12	8.50
13	1/4	3/32	2	.2000	12	8.90
14	5/16	7/64	2-1/8	.2500	12	8.90
15	7/16	5/32	2-3/4	.3500	12	14.50
16	1/2	3/16	3	.4000	6	19.50
17	5/8	7/32	3-1/4	.5000	1	27.50
18	3/4	1/4	3-1/2	.6000	1	38.00

METRIC SERIES — 60° COUNTERSINK ANGLE

- LIST NO. 585M



Size mm	Body Diameter	Drill Dia. and Length	Overall Length	Price Each
1.00	1/8	.0394	1-1/4	10.00
1.25	1/8	.0492	1-1/4	10.00
1.60	5/32	.0630	1-5/16	9.50
2.00	.1969	.0787	1-9/16	10.60
2.50	1/4	.0984	1-3/4	12.00
3.15	.3150	.1240	2	14.70
4.00	.3937	.1575	2-1/4	25.10
5.00	.4921	.1969	2-1/2	34.70
6.30	.6299	.2480	2-3/4	50.80
8.00	.7874	.3150	3-1/8	79.00

COBALT COMBINED DRILLS AND COUNTERSINKS



PLAIN TYPE - 60° COUNTERSINK ANGLE

- LIST NO. 585C — COBALT PREMIUM IMPORT
- LIST NO. 585CU — COBALT MADE IN U.S.A.



Size	Body Diameter	Drill Dia. and Length	Overall Length	Package Quantity	Price Each	
					Cobalt Import 585C	Cobalt USA 585CU
1	1/8	3/64	1-1/4	12	15.00	17.70
2	3/16	5/64	1-7/8	12	15.30	18.00
3	1/4	7/64	2	12	16.04	18.87
4	5/16	1/8	2-1/8	12	16.46	19.37
4-1/2	3/8	9/64	2-1/2	6	24.95	26.88
5	7/16	3/16	2-3/4	6	30.63	36.14
6	1/2	7/32	3	6	41.20	48.47
7	5/8	1/4	3-1/4	1	53.26	62.66
8	3/4	5/16	3-1/2	1	76.00	89.43

SOLID CARBIDE COMBINED DRILLS AND COUNTERSINKS

PLAIN TYPE - 60° COUNTERSINK ANGLE

- LIST NO. 585SC — SOLID CARBIDE



Size	Body Diameter	Drill Dia. and Length	Overall Length	Price Each
0	1/8	1/32	1-1/4	24.50
1	1/8	3/64	1-1/4	21.00
2	3/16	5/64	1-7/8	32.89
3	1/4	7/64	2	39.19
4	5/16	1/8	2-1/8	53.80
5	7/16	3/16	2-3/4	81.59
6	1/2	7/32	3	118.59

CARBIDE TIPPED COMBINED DRILLS AND COUNTERSINKS

60° COUNTERSINK ANGLE

- LIST NO. CT870 — 120° POINT



These drills are used for center drilling hardened high speed steel in the range up to 65R.

Size	Body Diameter	Drill Diameter	Overall Length	Price Each
4-1	5/16	3/32	2-1/8	60.02
4-2	5/16	1/8	2-1/8	60.02
6-1	1/2	7/32	3	76.66
6-2	1/2	9/32	3	76.66

SETS



Set No.	Set Description	Pieces per Set	Set Type	Set Price
▶ HIGH SPEED STEEL				
585P5	No. 1-5 Premium Import	5	High Speed Steel Plain Type, 60°	30.40
585P8	No. 1-8 Premium Import	8	High Speed Steel Plain Type, 60°	88.78
587B	No. 11-15 Bell	5	High Speed Steel Bell Type	42.47
● COBALT, USA SOLID CARBIDE, HIGH SPEED STEEL				
585UP5	No. 1-5 Made in USA	5	High Speed Steel Plain Type, 60°	35.90
585PTIN	No. 1-5 Titanium Coated	5	High Speed Steel Plain Type, 60°	41.94
585CP	No. 1-5 Premium Import	5	Cobalt	93.43
585CUP	No. 1-5 Made in USA	5	Cobalt	110.00
585UP8	No. 1-8 Made in USA	8	High Speed Steel Plain Type, 60°	108.65
585SC5	No. 1-5 Solid Carbide	5	Solid Carbide	228.00



NC/CNC SPOTTING DRILLS

STANDARD LENGTH

90° POINT

- ▶ LIST NO. 309 — HIGH SPEED
- LIST NO. 309C — COBALT
- LIST NO. 309T — TIN COATED

120° POINT

- ▶ LIST NO. 310 — HIGH SPEED
- LIST NO. 310C — COBALT
- LIST NO. 310T — TIN COATED

82° POINT

- ▶ LIST NO. 311 — HIGH SPEED
- LIST NO. 311C — COBALT
- LIST NO. 311T — TIN COATED

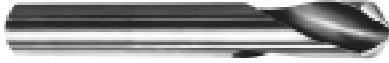

These drills are used for perfect alignment of the follow-on tool.

Size	Dec. Equiv.	Overall Length	Flute Length	Price Each			Price Each			Price Each		
				90° POINT			120° POINT			82° POINT		
				H.S. List No. 309	Cobalt List No. 309C	H.S. TiN Coated List No. 309T	H.S. List No. 310	Cobalt List No. 310C	H.S. TiN Coated List No. 310T	H.S. List No. 311	Cobalt List No. 311C	H.S. TiN Coated List No. 311T
1/8	.1250	1-7/8	1/2	18.45	35.10	26.75	19.20	35.85	27.84	19.20	35.85	27.84
5/32	.1562	2-1/16	9/16	20.50	39.00	29.72	21.25	39.75	30.81	21.25	39.75	30.81
3/16	.1875	2-3/16	9/16	21.80	42.00	31.61	22.40	42.60	32.48	22.40	42.60	32.48
1/4	.2500	2-1/2	3/4	24.30	44.85	35.23	24.80	45.75	35.96	24.80	45.75	35.96
3/8	.3750	3-1/8	1-1/8	26.15	48.35	37.91	26.70	49.25	38.71	26.70	49.25	38.71
1/2	.5000	3-3/4	1-3/8	33.46	61.95	48.51	34.20	63.15	49.59	34.20	63.15	49.59
5/8	.6250	4-3/8	1-5/8	44.25	81.90	64.16	44.30	81.90	64.23	44.30	81.90	64.23
3/4	.7500	5	1-7/8	55.86	103.30	80.99	56.95	105.35	82.57	56.95	105.35	82.57
1	1.0000	6	2-1/4	94.30	174.40	136.73	96.20	177.85	139.49	96.20	177.85	139.49

SETS

The following sets are all made of these sizes supplied in a wood case.
1/4, 3/8, 1/2, 5/8, 3/4, 1

H.S.—90° POINT

SET NO. 309S
SET PRICE — \$289.00

Cobalt—90° POINT

SET NO. 309CS
SET PRICE — \$519.00

H.S.—120° POINT

SET NO. 310S
SET PRICE — \$299.00

Cobalt—120° POINT

SET NO. 310CS
SET PRICE — \$539.00

H.S.—82° POINT

SET NO. 311S
SET PRICE — \$299.00

Cobalt—82° POINT

SET NO. 311CS
SET PRICE — \$539.00

LONG LENGTH

90° POINT

- ▶ LIST NO. 309L — HIGH SPEED
- LIST NO. 309LT — TIN COATED

120° POINT

- ▶ LIST NO. 310L — HIGH SPEED
- LIST NO. 310LT — TIN COATED



H.S.—90° POINT

6 Piece Set
Contains 1 piece of each:
1/4, 3/8, 1/2, 5/8, 3/4, 1
Supplied in wood block.

SET NO. 309LS
SET PRICE — \$359.00

Size	Dec. Equiv.	Overall Length	Flute Length	Price Each	
				90° POINT	
				H.S. List No. 309L	H.S. TiN Coated List No. 309LT
1/4	.2500	4	3/4	35.50	51.47
3/8	.3750	5	1-1/8	37.25	54.01
1/2	.5000	6	1-3/8	46.50	67.42
5/8	.6250	7	1-5/8	59.50	86.27
3/4	.7500	8	1-7/8	79.90	115.85
1	1.0000	8	2-1/4	101.75	147.53

Size	Dec. Equiv.	Overall Length	Flute Length	Price Each	
				120° POINT	
				H.S. List No. 310L	H.S. TiN Coated List No. 310LT
1/4	.2500	4	3/4	36.25	52.56
3/8	.3750	5	1-1/8	38.10	55.24
1/2	.5000	6	1-3/8	47.60	69.02
5/8	.6250	7	1-5/8	61.10	88.59
3/4	.7500	8	1-7/8	81.50	118.17
1	1.0000	8	2-1/4	103.80	150.51

H.S.—120° POINT

6 Piece Set
Contains 1 piece of each:
1/4, 3/8, 1/2, 5/8, 3/4, 1
Supplied in wood block.

SET NO. 310LS
SET PRICE — \$369.00

EXTRA LENGTH

90° POINT

- ▶ LIST NO. 309XL — HIGH SPEED
- LIST NO. 309XLT — TIN COATED

120° POINT

- ▶ LIST NO. 310XL — HIGH SPEED
- LIST NO. 310XLT — TIN COATED



H.S.—90° POINT

6 Piece Set
Contains 1 piece of each:
1/4, 3/8, 1/2, 5/8, 3/4, 1
Supplied in wood block.

SET NO. 309XLS
SET PRICE — \$489.00

Size	Dec. Equiv.	Overall Length	Flute Length	Price Each	
				90° POINT	
				H.S. List No. 309XL	H.S. TiN Coated List No. 309XLT
1/4	.2500	6	3/4	49.50	71.77
3/8	.3750	7	1-1/8	52.15	75.61
1/2	.5000	8	1-3/8	63.29	91.77
5/8	.6250	9	1-5/8	82.85	120.13
3/4	.7500	10	1-7/8	107.90	156.45
1	1.0000	10	2-1/4	132.10	191.54

Size	Dec. Equiv.	Overall Length	Flute Length	Price Each	
				120° POINT	
				H.S. List No. 310XL	H.S. TiN Coated List No. 310XLT
1/4	.2500	6	3/4	51.15	74.16
3/8	.3750	7	1-1/8	53.25	77.21
1/2	.5000	8	1-3/8	64.70	93.81
5/8	.6250	9	1-5/8	83.15	120.56
3/4	.7500	10	1-7/8	110.10	159.64
1	1.0000	10	2-1/4	135.20	196.04

H.S.—120° POINT

6 Piece Set
Contains 1 piece of each:
1/4, 3/8, 1/2, 5/8, 3/4, 1
Supplied in wood block.

SET NO. 310XLS
SET PRICE — \$499.00



NC/CNC SPOTTING METRIC DRILLS

STANDARD LENGTH

90° POINT

- LIST NO. 309 — HIGH SPEED
- LIST NO. 309C — COBALT
- LIST NO. 309T — TiN COATED

120° POINT

- LIST NO. 310 — HIGH SPEED
- LIST NO. 310C — COBALT
- LIST NO. 310T — TiN COATED

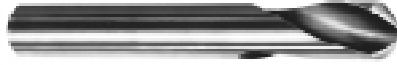

These drills are used for perfect alignment of the follow-on tool.

Size mm	Dec. Equiv.	Overall Length	Flute Length	Price Each			Price Each		
				90° POINT			120° POINT		
				H.S. List No. 309	Cobalt List No. 309C	H.S. TiN Coated List No. 309T	H.S. List No. 310	Cobalt List No. 310C	H.S. TiN Coated List No. 310T
4.00	.1575	2-1/16	15/32	21.00	40.10	30.45	21.84	41.30	31.66
6.00	.2362	2-19/32	5/8	23.00	43.05	33.35	23.92	44.34	34.68
8.00	.3150	3-1/8	13/16	25.00	45.05	36.25	26.00	46.40	37.70
10.00	.3937	3-1/2	1	31.00	59.15	44.95	32.24	60.92	46.74
12.00	.4724	4	1-3/16	35.00	60.95	50.75	36.40	62.78	52.78
14.00	.5512	4-1/2	1-3/8	39.00	76.95	56.55	40.56	79.26	58.81
16.00	.6299	4-1/2	1-3/8	45.00	86.05	65.25	46.80	88.63	67.86
18.00	.7087	5-1/8	1-1/2	52.00	101.95	75.40	54.08	105.00	78.41

6 Piece Sets Sizes: 6, 8, 10, 12, 14, 16 Supplied in wood case
HIGH SPEED STEEL
SET NO. 309SM 90°PT SET PRICE — \$198.00
SET NO. 310SM 120°PT SET PRICE — \$205.00
COBALT
SET NO. 309CSM 90°PT SET PRICE — \$389.15
SET NO. 310CSM 120°PT SET PRICE — \$400.28

SOLID CARBIDE NC SPOTTING DRILLS

- LIST NO. C809 — 90° POINT
- LIST NO. C810 — 120° POINT

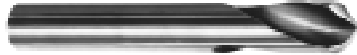

Designed for fast and accurate spotting on NC machines. These drills are very rigid allowing higher speeds and feeds.

Size	Dec. Equiv.	Flute Length	Overall Length	Price Each	
				90° List No. C809	120° List No. C810
1/8	.1250	3/8	1-1/2	18.95	18.95
3/16	.1875	1/2	2	24.50	24.50
1/4	.2500	5/8	2	32.50	32.50
3/8	.3750	1	2	59.00	59.00
1/2	.5000	1	2	88.90	88.90
3/4	.7500	1-1/4	2-5/8	235.60	235.60

HIGH SPEED STEEL

CENTER DRILLS

- ▶ LIST NO. 580 — 118° POINT



These drills are used for starting and centering screw machine operations. Their short flute and overall length increase rigidity while minimizing runout.

Size	Dec. Equiv.	Flute Length	Overall Length	Price Each	Size	Dec. Equiv.	Flute Length	Overall Length	Price Each
#56	.0465	3/8	1-3/16	2.70	#20	.1610	1	1-1/2	4.35
1/16*	.0625	3/8	1-3/16	2.70	11/64	.1719	1	1-1/2	4.35
5/64	.0781	3/4	1-1/4	2.70	3/16	.1875	1	1-1/2	4.35
3/32	.0938	3/4	1-1/4	2.95	13/64	.2031	1	1-1/2	4.35
#40	.0980	3/4	1-1/4	2.95	#5	.2055	1	1-1/2	4.35
7/64	.1094	3/4	1-1/4	2.95	7/32	.2188	1	1-1/2	4.35
1/8	.1250	3/4	1-1/4	2.50	1/4	.2500	1	1-1/2	4.85
#30	.1285	3/4	1-1/4	2.60	9/32	.2812	1	1-1/2	6.75
9/64	.1406	3/4	1-1/4	3.90	5/16	.3125	1	1-1/2	8.00
5/32	.1562	1	1-1/2	4.35	29/64	.4531	1	1-1/2	12.90

*This size available in Cobalt, Price Each \$4.86

HIGH SPEED STEEL

SPOTTING AND CENTERING DRILLS

- LIST NO. 302 — RIGHT HAND, 118° POINT
- LIST NO. 302LH — LEFT HAND, 118° POINT



These drills are used for starting and centering screw machine operations. Their short flute and overall length increase rigidity while minimizing runout. To provide greater rigidity, these drills are made with short overall and flute lengths.

Size	Dec. Equiv.	Flute Length	Overall Length	Price Each	
				Right Hand List No. 302	Left Hand List No. 302LH
3/8	.3750	1	2	9.80	14.50
7/16	.4375	1	2	16.00	19.70
1/2	.5000	1	2	17.20	21.15
5/8	.6250	1-1/8	2-1/4	27.30	33.00
3/4	.7500	1-1/8	2-1/4	38.90	46.00
7/8	.8750	1-1/4	2-1/2	55.90	65.00

Size	Dec. Equiv.	Flute Length	Overall Length	Price Each	
				Right Hand List No. 302	Left Hand List No. 302LH
1	1.0000	1-1/4	2-1/2	62.80	69.75
1-1/4	1.2500	2	4	125.00	—
1-1/2	1.5000	2-1/2	5	195.00	—
1-3/4	1.7500	2-3/4	5-1/2	295.00	—
2	2.0000	3-3/4	6	350.00	—



HIGH SPEED STEEL

SINGLE-FLUTE COUNTERSINKS

- ▶ LIST NO. 490 — 60° POINT ANGLE
- ▶ LIST NO. 491 — 82° POINT ANGLE
- ▶ LIST NO. 492 — 90° POINT ANGLE
- ▶ LIST NO. 493 — 100° POINT ANGLE

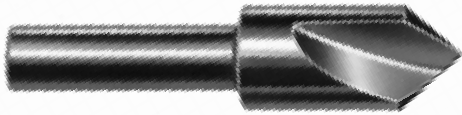

For use in chamfering, deburring, countersinking and enlarging holes in sheet metal while providing a smooth surface finish. They will countersink holes much smaller than other styles and should be operated at comparatively high speeds.

SINGLE TOOLS							
Size	Shank Dia.	Overall Length	Price Each	Size	Shank Dia.	Overall Length	Price Each
1/8	1/8	1-1/4	10.92	3/4	1/2	2-5/8	39.20
3/16	3/16	1-1/2	11.96	7/8	1/2	2-3/4	53.00
1/4	1/4	1-1/2	14.50	1	1/2	2-3/4	67.00
5/16	1/4	1-5/8	15.50	1-1/4	1/2	2-3/4	111.97
3/8	1/4	1-3/4	16.50	1-1/2	3/4	2-7/8	139.61
1/2	1/4	2	21.20	1-3/4	3/4	3	197.50
5/8	3/8	2-1/4	29.15	2	3/4	3-1/4	227.17

SETS

5 PIECE SETS
 Contains 1 Piece of Each:
 1/4, 3/8, 1/2, 5/8, 3/4
 60° – SET NO. 490S5
 82° – SET NO. 491S5
 90° – SET NO. 492S5
 100° – SET NO. 493S5
 Supplied in Wood Block
SET PRICE - \$120.50

SETS

9 PIECE SETS
 Contains 1 Piece of Each:
 1/4, 3/8, 1/2, 5/8, 3/4
 1, 1-1/4, 1-1/2, 2
 60° – SET NO. 490S9
 82° – SET NO. 491S9
 90° – SET NO. 492S9
 100° – SET NO. 493S9
 Supplied in Wood Block
SET PRICE - \$667.00

SETS

12 PIECE SETS
 Contains 1 Piece of Each:
 3/16, 1/4, 5/16, 3/8, 1/2, 5/8,
 3/4, 7/8, 1, 1-1/4, 1-1/2, 2
 60° – SET NO. 490S12
 82° – SET NO. 491S12
 90° – SET NO. 492S12
 100° – SET NO. 493S12
 Supplied in Wood Block
SET PRICE - \$746.50

HIGH SPEED STEEL

THREE-FLUTE COUNTERSINK CENTER REAMERS

- ▶ LIST NO. 480 — 60° POINT ANGLE
- ▶ LIST NO. 481 — 82° POINT ANGLE
- ▶ LIST NO. 482 — 90° POINT ANGLE
- ▶ LIST NO. 483 — 100° POINT ANGLE*
- ▶ LIST NO. 484 — 120° POINT ANGLE*

* 1/4-1" ONLY

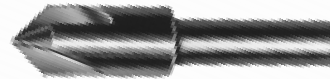

Engineered to give chatter-free performance. They are comparatively free-cutting and should be operated at low speeds.

SETS

5 PIECE SETS
 Contains 1 Piece of Each:
 1/4, 3/8, 1/2, 5/8, 3/4
 60° – SET NO. 480S5
 82° – SET NO. 481S5
 90° – SET NO. 482S5
 Supplied in Wood Block
SET PRICE - \$97.20

SETS

9 PIECE SETS
 Contains 1 Piece of Each:
 1/4, 3/8, 1/2, 5/8, 3/4
 1, 1-1/4, 1-1/2, 2
 60° – SET NO. 480S9
 82° – SET NO. 481S9
 90° – SET NO. 482S9
 Supplied in Wood Block
SET PRICE - \$545.10

SINGLE TOOLS							
Size	Shank Dia.	Overall Length	Price Each	Size	Shank Dia.	Overall Length	Price Each
1/4	3/16	1-1/2	11.00	1	1/2	2-3/4	51.68
3/8	1/4	1-3/4	13.10	1-1/4	1/2	3	86.65
1/2	3/8	2	16.50	1-1/2	3/4	3	111.80
5/8	3/8	2-1/4	24.50	2	3/4	3-1/4	197.60
3/4	1/2	2-5/8	32.10				

HIGH SPEED STEEL

FOUR-FLUTE MACHINE COUNTERSINKS

- ▶ LIST NO. 486 — 60° POINT ANGLE
- ▶ LIST NO. 487 — 82° POINT ANGLE

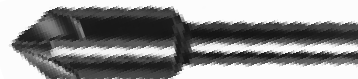

Four flute countersinks allow for greater chip removal.

SETS

5 PIECE SETS
 Contains 1 Piece of Each:
 1/2, 5/8, 3/4, 7/8, 1
 60° – SET NO. 486S5
 82° – SET NO. 487S5
 Supplied in Wood Block
SET PRICE - \$252.35

SINGLE TOOLS							
Size	Shank Dia.	Overall Length	Price Each	Size	Shank Dia.	Overall Length	Price Each
1/2	1/2	3-7/8	35.50	1	1/2	4-1/4	64.50
5/8	1/2	4	41.25	1-1/4	1/2	4-3/8	85.60
3/4	1/2	4-1/8	52.80	1-1/2	1/2	4-1/2	113.75
7/8	1/2	4-1/4	58.30				



SIX-FLUTE CHATTERLESS COUNTERSINKS

- ▶ LIST NO. 495 — 60° POINT ANGLE
- ▶ LIST NO. 496 — 82° POINT ANGLE
- ▶ LIST NO. 497 — 90° POINT ANGLE
- ▶ LIST NO. 498 — 100° POINT ANGLE

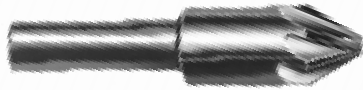

Designed for fast shearing cut.



SINGLE TOOLS							
Size	Shank Dia.	Overall Length	Price Each	Size	Shank Dia.	Overall Length	Price Each
1/4	1/4	2	12.38	1	1/2	2-3/4	63.20
5/16	1/4	2	14.75	1-1/4	3/4	3-3/8	102.95
3/8	1/4	2	16.81	1-1/2	3/4	3-1/2	152.50
1/2	1/4	2	21.00	1-3/4	1	4-1/4	191.25
5/8	1/2	2-3/4	30.50	2	1	4-3/8	229.25
3/4	1/2	2-3/4	43.50	2-1/2	1	5	275.10
7/8	1/2	2-3/4	52.50	3	1	5-1/4	330.12

SETS
5 PIECE SETS Contains 1 Piece of Each: 1/4, 3/8, 1/2, 5/8, 3/4 60° – SET NO. 495S5 82° – SET NO. 496S5 90° – SET NO. 497S5 100° – SET NO. 498S5 Supplied in Wood Block SET PRICE - \$125.00

SETS
8 PIECE SETS Contains 1 Piece of Each: 1/4, 5/16, 3/8, 1/2, 5/8, 3/4, 7/8, 1 60° – SET NO. 495S8 82° – SET NO. 496S8 90° – SET NO. 497S8 100° – SET NO. 498S8 Supplied in Wood Block SET PRICE - \$255.00

COBALT SINGLE-FLUTE COUNTERSINKS



- LIST NO. 491C — 82° POINT ANGLE

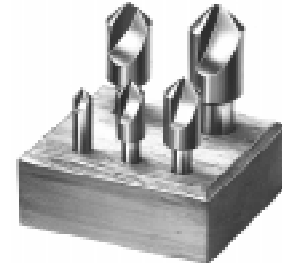

SINGLE TOOLS							
Size	Shank Dia.	Overall Length	Price Each	Size	Shank Dia.	Overall Length	Price Each
1/8	1/8	1-1/4	19.66	3/4	1/2	2-5/8	70.56
3/16	3/16	1-1/2	21.53	7/8	1/2	2-3/4	95.40
1/4	1/4	1-1/2	26.80	1	1/2	2-3/4	120.60
5/16	1/4	1-5/8	27.90	1-1/4	1/2	2-3/4	201.55
3/8	1/4	1-3/4	29.70	1-1/2	3/4	2-7/8	251.30
1/2	1/4	2	38.16	1-3/4	3/4	3	355.50
5/8	3/8	2-1/4	52.97	2	3/4	3-1/4	408.91

SETS
82° — SET NO. 491CS5 5 PIECE SETS Contains 1 Piece of Each: 1/4, 3/8, 1/2, 5/8, 3/4 Supplied in Wood Block SET PRICE - \$217.00

SETS
82° — SET NO. 491CS9 9 PIECE SETS Contains 1 Piece of Each: 1/4, 3/8, 1/2, 5/8, 3/4 1, 1-1/4, 1-1/2, 2 Supplied in Wood Block SET PRICE - \$1200.00

COBALT THREE-FLUTE CENTER REAMERS



- LIST NO. 481C — 82° POINT ANGLE

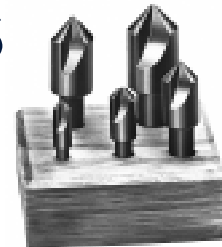

SINGLE TOOLS							
Size	Shank Dia.	Overall Length	Price Each	Size	Shank Dia.	Overall Length	Price Each
1/4	3/16	1-1/2	19.80	1	1/2	2-3/4	93.02
3/8	1/4	1-3/4	23.58	1-1/4	1/2	3	155.97
1/2	3/8	2	29.70	1-1/2	3/4	3	201.24
5/8	3/8	2-1/4	44.10	2	3/4	3-1/4	355.68
3/4	1/2	2-5/8	57.78				

SETS
82° — SET NO. 481CS5 5 PIECE SETS Contains 1 Piece of Each: 1/4, 3/8, 1/2, 5/8, 3/4 Supplied in Wood Block SET PRICE - \$175.00

SETS
82° — SET NO. 481CS9 9 PIECE SETS Contains 1 Piece of Each: 1/4, 3/8, 1/2, 5/8, 3/4 1, 1-1/4, 1-1/2, 2 Supplied in Wood Block SET PRICE - \$980.91



HIGH SPEED STEEL AND COBALT

COUNTERSINK AND DEBURRING TOOL

PILOTED AND PILOTLESS TYPES

MADE IN U.S.A.



The action of a single cutting edge provides faster stock removal and prevents chatter. These tools are recommended for deburring steel and other ferrous materials. They can easily be resharpened by using an axial relieving fixture or by using a small mounted grinding wheel and inserting it in the hole.

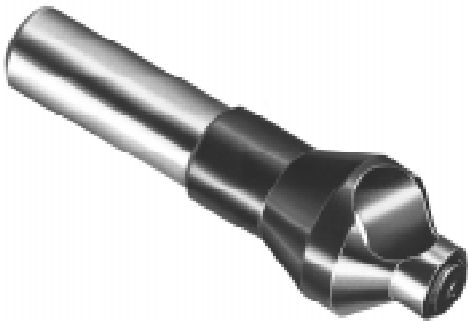

SINGLE TOOLS - PILOTLESS TYPE

Size	Single or Double End	Range of Hole Diameter Which Can Be Cut		Shank Dia.	Price Each	
		Smallest Dia.	Largest Dia.		H.S.	Cobalt
LIST NO. 543 — 60° HIGH SPEED					H.S. 543	Cobalt
00	Double End	3/32	11/64	3/16	9.32	—
0	Double End	1/8	15/64	1/4	9.32	—
1	Single End	3/16	13/32	1/4	10.10	—
2	Single End	5/16	17/32	1/4	12.50	—
3	Single End	7/16	25/32	1/2	21.65	—
3A	Single End	7/16	25/32	1/4	21.65	—
4	Single End	11/16	1-3/32	1/2	34.25	—
LIST NO. 544 — 82° HIGH SPEED					H.S. 544	Cobalt 544C
LIST NO. 544C — 82° COBALT						
0	Double End	1/16	15/64	1/4	9.32	16.78
1	Single End	5/32	13/32	1/4	9.32	16.78
2	Single End	3/16	17/32	1/4	11.67	21.01
3	Single End	5/16	25/32	1/2	20.24	36.43
3A	Single End	5/16	25/32	1/4	20.24	36.43
3B	Single End	7/16	7/8	1/2	34.39	—
4	Single End	9/16	1-1/16	1/2	34.25	61.65
5	Single End	5/8	1-15/32	1/2	77.64	139.75
6	Single End	3/4	1-3/4	5/8	113.00	—
7	Single End	1	2	5/8	138.36	—
8	Single End	1-1/4	2-1/2	3/4	153.50	—
LIST NO. 546 — 90° HIGH SPEED					H.S. 546	Cobalt 546C
LIST NO. 546C — 90° COBALT						
00	Double End	1/32	11/64	3/16	9.32	—
0	Double End	1/16	15/64	1/4	9.32	16.78
1	Single End	5/32	13/32	1/4	9.32	16.78
2	Single End	3/16	17/32	1/4	11.67	21.01
3	Single End	5/16	25/32	1/2	20.24	36.43
3A	Single End	5/16	25/32	1/4	20.24	—
4	Single End	9/16	1-1/16	1/2	34.25	61.65
5	Single End	5/8	1-15/32	1/2	77.64	—
LIST NO. 547 — 100° HIGH SPEED					H.S. 547	Cobalt
0	Double End	1/16	15/64	1/4	9.32	—
1	Single End	5/32	13/32	1/4	10.10	—
2	Single End	3/16	17/32	1/4	12.50	—
3	Single End	5/16	25/32	1/2	21.65	—
4	Single End	9/16	1-1/16	1/2	35.85	—

SINGLE TOOLS - PILOTED TYPE

Size	Screw Size	Range of Hole Diameter Which Can Be Cut		Pilot Length	Shank Dia.	Price Each
		Smallest Dia.*	Largest Dia.			
LIST NO. 544P — 82°						
11	1/4	1/4	33/64	5/32	3/8	13.52
12	1/4	17/64	33/64	5/32	3/8	13.52
13	5/16	5/16	41/64	5/32	3/8	16.15
14	5/16	21/64	41/64	5/32	3/8	16.15
15	3/8	3/8	49/64	5/32	1/2	21.43
16	3/8	25/64	49/64	5/32	1/2	21.43
17	7/16	7/16	53/64	7/32	1/2	26.68
18	7/16	29/64	53/64	7/32	1/2	26.68
19	1/2	1/2	15/16	1/4	1/2	27.72
20	1/2	33/64	15/16	1/4	1/2	27.72

*Pilot Diameter

HIGH SPEED STEEL SETS

Pilotless Type (Pictured at Right)

5 Piece Set
Contains 1 Piece of Each:
#0, 1, 2, 3 and 4
60° SET NO. 543S — \$ 87.82
82° SET NO. 544S — \$ 84.80
90° SET NO. 546S — \$ 84.80
100° SET NO. 547S — \$ 89.42

SET NO. 544T
8 Piece Set - 82° Point Angle
Contains 1 Piece of Each:
0, 1, 2, 3, 4, 5, 6 and 7
SET PRICE — \$413.80

Piloted Type (Pictured at Right)

SET NO. 544PS
5 Piece Set - 82° Point Angle
Contains 1 Piece of Each:
#11, 13, 15, 17 and 19
SET PRICE — \$105.50

Sets supplied in wood block

COBALT SETS

5 Piece Set
Contains 1 Piece of Each:
#0, 1, 2, 3 and 4
Supplied in Wood Block
82° SET NO. 544CS — \$152.64
90° SET NO. 546CS — \$152.64

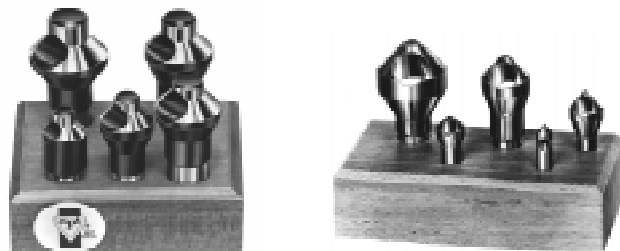

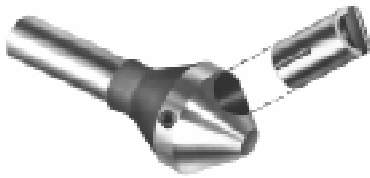

◆ DYNA-SINK

**HIGH SPEED STEEL AND CARBIDE INSERTED
COUNTERSINK AND DEBURRING TOOLS
82° AND 90°**

- Deburr and Countersink large diameter holes
- Use at high surface speeds
- Better finishes
- Quick and inexpensive
- Inserts need only be replaced after a large number of regrinds
- Regrind is quick and accurate

SINGLE TOOL

Size No.	Range of Hole Diameter Which Can be Cut		Shank Dia.	Tool No.		Price Each
	Smallest Dia. to Largest Dia.			82°	90°	
4	9/16	1-1/16	1/2	548-48	548-49	27.50
5	1	1-1/2	3/4	548-58	548-59	39.50
7	1-1/2	2	3/4	548-78	548-79	57.00

Inserts sold separately

INSERTS

High Speed Steel		Carbide	
Insert No.	Price Each	Insert No.	Price Each
548HA4	25.87	548CA4	28.64
548HA5	25.87	548CA5	28.64
548HA7	25.87	548CA7	28.64

REPLACEMENT PARTS LIST

Part No.	Description	Price Each
SS1420-38	Dyna-Sink Set Screw	.50
SS51618-38	Resharpener Fixture Set Screw	.35

SETS

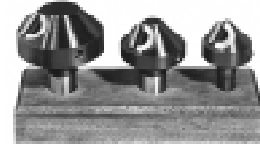

3 PIECE SET

Contains 1 piece of each:
Size No. 4, 5, 7
Inserts included with each set
supplied in wood block

HIGH SPEED INSERTED SET

82° SET NO. 548SH8 — PRICE \$149.00
90° SET NO. 548SH9 — PRICE \$149.00

3 PIECE SET

Contains 1 piece of each:
Size No. 4, 5, 7
Inserts included with each set
supplied in wood block

CARBIDE INSERTED SET

82° SET NO. 548SC8 — PRICE \$152.00
90° SET NO. 548SC9 — PRICE \$152.00

DYNA-SINK RESHARPENING FIXTURE

For use in spin fixture
Tool No. 548R
PRICE EACH — \$33.93



MADE IN U.S.A. — EXCLUSIVELY BY A.P.T.

◆ INDEXABLE COUNTERSINK AND CHAMFERING TOOL

**POSITIVE RAKE
60°, 82°, 90° AND 100°**



SINGLE TOOL

Cutter Body		Shank Size	Use Insert No.	Tool No.				Price Each
Min	Max			60°	82°	90°	100°	
1/8	1/2	3/8	TPGH21.51	CC060	CC082	CC090	CC000	69.00
1/4	3/4	1/2	TPGH321	CC160	CC182	CC190	CC100	88.00
1/2	1-3/4	1/2	SPGH433	CC260	CC282	CC290	CC200	129.00
1-1/4	2-1/2	3/4	SPGH433	CC360	CC382	CC390	CC300	169.00

- C-6 Carbide insert and Torx® wrench included with each tool
- Positive rake for smooth cutting without chatter
- Carbide indexable — No tool resharpener needed
- Uses standard triangle and square inserts

SETS

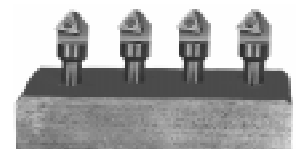
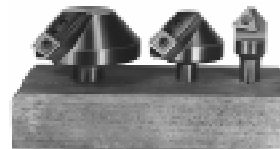

3 PIECE SETS

Contains 1 Piece of Each:
1/4, 1/2 and 1-1/4 (Min.)
Inserts and torx® wrench
included with each set
supplied in wood block
CCS60 — 60° SET
CCS82 — 82° SET
CCS90 — 90° SET
CCS100 — 100° SET
PRICE — \$391.00

4 PIECE SET

Contains 1 Piece of Each:
CC060
CC082
CC090
CC000
Inserts and torx® wrench
included with set
supplied in wood block
PRICE — \$274.00
SET NO. — CCS0CMB



TPGH



SPGH

CARBIDE INSERTS

Insert Style	Insert Number	Radius	I.C.	Thickness	Price Each		
					C-2	C-5 & C-6	TiN Coated*
Triangle	TPGH21.51	1/64	1/4	3/32	4.75	5.23	6.11
Triangle	TPGH-321	1/64	3/8	1/8	5.13	5.70	6.95
Square	SPGH-433	3/64	1/2	3/16	9.45	9.95	11.95

*C-5 & C-6 Grade TiN Coated

REPLACEMENT PARTS LIST

Part No.	Description	Price Each
TF832-285	Torx® drive flat head screw for 1/2, 3/8 I.C.	1.75
TF440-195	Torx® drive flat head screw for 1/4 I.C.	1.25
CTW-10	Torx® wrench for 1/2, 3/8 I.C.	2.45
CTW-6	Torx® wrench — T6	1.95

SOLID PILOT COUNTERBORES

SOCKET CAP SCREW

● LIST NO. 508 — THREE FLUTE, STRAIGHT SHANK

Solid Pilot Counterbores are .001 - .002 undersize for ease of entry.



● LIST NO. 509 — THREE FLUTE, TAPER SHANK

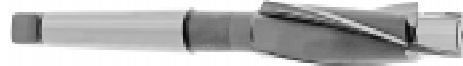

SET NO. 508S7

7 Piece SS Set
 Contains 1 piece each:
 No.6, No.8, No.10
 1/4, 5/16, 3/8, 1/2
 Supplied in Wood Block
SET PRICE — \$177.00

SET NO. 508S6

6 Piece SS Set
 Contains 1 piece each:
 1/4, 5/16, 3/8, 1/2, 5/8, 3/4
 Supplied in Wood Block
SET PRICE — \$256.00

Screw Size	Pilot Diameter	Cutting Diameter	Shank Diameter	Overall Length	Price Each	Morse Taper No.	Price Each
					List No. 508		List No. 509
No.5	.141	.221	3/16	3	19.50	—	—
No.6	.150	.242	7/32	3	19.50	—	—
No.8	11/64	19/64	1/4	3	19.50	—	—
No.10	13/64	21/64	5/16	3-1/2	20.64	—	—
1/4	9/32	13/32	3/8	3	23.50	2	23.50
5/16	11/32	1/2	7/16	5	25.65	2	25.65
3/8	13/32	19/32	1/2	6	29.30	2	29.30
7/16	15/32	11/16	1/2	7	35.02	2	35.02
1/2	17/32	25/32	1/2	7-1/2	39.90	2	39.90
1/2	17/32	25/32	3/4	7-1/2	39.90	—	—
1/2	9/16	13/16	3/4	7-1/2	39.90	—	—
5/8	21/32	31/32	3/4	7-1/2	57.37	2	57.37
5/8	11/16	1	3/4	7-1/2	57.37	—	—
3/4	13/16	1-3/16	1	8	81.22	3	81.22
7/8	15/16	1-3/8	1	8	122.11	3	122.11
1	1-1/16	1-9/16	1	10	158.47	3	158.47

SET NO. 508S4

4 Piece SS Set
 Contains 1 piece each:
 No.8, No.10, 1/4, 3/8
 Supplied in Wood Block
SET PRICE — \$92.00

SET NO. 509S6

6 Piece TS Set
 Contains 1 piece each:
 1/4, 5/16, 3/8, 1/2, 5/8, 3/4
 Supplied in Wood Block
SET PRICE — \$256.00

● LIST NO. 508M — THREE FLUTE

METRIC STRAIGHT SHANK



SET NO. 508S7M

7 Piece SS Set
 Contains 1 piece each:
 3mm, 4mm, 5mm, 6mm
 8mm, 10mm, 12mm
 Supplied in Wood Block
SET PRICE — \$172.11

Screw Size mm	Pilot Diameter mm	Cutting Diameter mm	Shank Diameter Inches	Overall Length Inches	Price Each
3	3.4	6	7/32	3	19.50
4	4.5	8	5/16	3-1/2	19.50
5	5.5	10	5/16	4-1/2	20.64
6	6.6	11	1/2	5	23.50
8	9	15	1/2	6	25.65
10	11	18	1/2	7	29.30
12	14	20	5/8	7-1/2	35.02
14	15	24	3/4	8	39.90
16	17	26	1	9	57.37
20	21	33	1	10	81.22

● LIST NO. 509M — THREE FLUTE

METRIC TAPER SHANK
 #2 MORSE TAPER

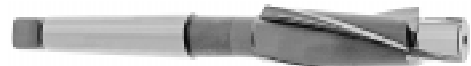

Screw Size mm	Pilot Dia. mm	Cutting Dia. mm	Overall Length mm	Price Each
14	15	24	60	39.90
16	17	26	79	57.37
20	21	33	79	81.22

HIGH SPEED STEEL

COUNTERBORES FOR FILLISTER HEAD MACHINE SCREWS

● LIST NO. 502 — TWO FLUTE, STRAIGHT SHANK

Screw Size	Pilot Diameter	Cutting Diameter	Shank Diameter	Overall Length	Price Each
No.2	.085	.155	.1875	2-1/2	11.19
No.3	.098	.176	.1875	2-1/2	11.19
No.4	.111	.198	.2500	2-5/8	11.19
No.5	.124	.220	.2500	2-5/8	12.20
No.6	.137	.241	.2500	2-5/8	12.70
No.8	.163	.285	.3125	2-3/4	13.50
No.10	.189	.328	.3750	2-7/8	14.50
No.12	.215	.372	.3750	3	16.20
1/4	1/4	13/32	5/16	3-5/8	23.40
5/16	5/16	15/32	3/8	4	24.40
3/8	3/8	19/32	7/16	4-3/8	27.90
7/16	7/16	21/32	1/2	4-3/4	31.50
1/2	1/2	25/32	9/16	5-1/4	34.20



SET NO. 502SA

5 Piece Set
 Contains 1 piece each:
 No.2, No.4, No.6, No.8, No.10
 Supplied in Wood Block
SET PRICE — \$63.08

SET NO. 502SB

4 Piece Set
 Contains 1 piece each:
 1/4, 5/16, 3/8, 1/2
 Supplied in Wood Block
SET PRICE — \$109.90



HIGH SPEED STEEL

HOLE CUTTERS



These Hole Cutters are recommended for use in hand held air or electric drill motors as well as light drill press applications in sheet metal, thin wall tubing, steel plate or any other larger diameter shallow hole cutting.

This tool centers quickly and is held securely in position after the pilot drill has entered the work piece. The cutter body then cuts a clean, burr-free hole faster than conventional twist drills or hole saws.

With normal care, tool life is significantly longer than other hole cutting tools. Inexpensive resharpening will allow repeated use.

A versatile and highly useful tool!

HOLE CUTTER SET

SET NO. HC690S

Set contains 1 piece each 1/2", 5/8", 3/4", 1" with 1/2" Shanks and 1/4" Pilot Drills
Supplied in wood block
SET PRICE — \$168.00



◆ **LIST NO. HC690**

PILOT DRILL FURNISHED WITH EACH CUTTER

3/8" SHANK 3/16" Pilot		
Size	No. of Flutes	Price Each
1/2	4	30.45
9/16	4	39.00
5/8	4	41.45
1/2" SHANK 1/4" Pilot		
Size	No. of Flutes	Price Each
1/2	4	30.45
9/16	4	39.00
5/8	4	41.45
11/16	4	43.85
3/4	4	45.10
13/16	4	46.75
7/8	4	48.75
29/32	4	48.95
15/16	5	49.85
1	5	51.25
1-1/16	5	53.95
1-1/8	5	56.25
1-3/16	5	59.00
1-1/4	5	61.35
1-5/16	5	66.55
1-3/8	5	70.45
1-1/2	5	74.25
1-5/8	6	93.45
1-3/4	6	100.75
1-7/8	6	108.00
2	6	113.55

32nd, 64th and Metric Sizes available at a nominal extra charge.

HIGH SPEED STEEL

PILOT DRILLS

PILOT DRILL WITH SINGLE FLAT

For Use In Above Hole Cutters.



■ **LIST NO. 673**

135° SPLIT POINT

3/16" Diameter — **PRICE EACH \$1.89**
1/4" Diameter — **PRICE EACH \$2.59**

PILOT DRILL WITH TWO WHISTLE NOTCHES

For Use in Hole Saws, Hole Cutters and Other Pilot Tools.



■ **LIST NO. 671**
SPLIT POINT

1/4" Diameter — 4" Overall,
1-1/4" Flute Length
PRICE EACH \$2.84

Other sizes available by special order

HIGH SPEED STEEL

ANNULAR CUTTERS

- ▶ LIST NO. 251 — 1" DEPTH OF CUT
- ▶ LIST NO. 251T — 1" DEPTH OF CUT TIN COATED
- ▶ LIST NO. 252 — 2" DEPTH OF CUT

- ▶ LIST NO. 252T — 2" DEPTH OF CUT TIN COATED
- ▶ LIST NO. 253 — 3" DEPTH OF CUT
- ▶ LIST NO. 253T — 3" DEPTH OF CUT TIN COATED



All cutters come with 3/4" shank diameter with two flats. The Federal Annular Cutter is made of sturdy M-2 Steel construction, which enables you to cut a burr free hole. The Federal Annular Cutter penetrates rapidly, cutting only the periphery of the hole thus allowing the pilot pin to eject the center plug of steel.

FRACTIONAL SIZES

Dia. of Cut	Price Each					
	List No. 251	TiN Coated List No. 251T	List No. 252	TiN Coated List No. 252T	List No. 253	TiN Coated List No. 253T
7/16	40.44	59.14	55.99	79.95	—	—
1/2	40.94	60.97	57.75	82.41	—	—
9/16	42.67	62.70	59.60	84.25	—	—
5/8	46.14	66.17	66.24	90.90	—	—
11/16	46.69	66.71	68.42	93.08	—	—
3/4	50.76	70.78	75.05	99.70	—	—
13/16	52.60	72.63	76.79	101.44	—	—
7/8	58.84	78.87	87.75	112.40	199.52	289.30
15/16	61.15	81.17	90.63	115.29	123.49	179.06
1	68.09	88.12	99.28	123.94	135.22	196.06
1-1/16	68.22	88.24	99.28	123.89	135.22	196.06
1-1/8	75.05	95.07	113.17	137.82	154.20	223.59
1-3/16	77.35	106.09	117.80	154.14	160.58	232.84
1-1/4	90.05	118.79	129.35	165.69	176.20	255.49
1-5/16	112.00	140.74	140.90	177.24	191.96	278.34
1-3/8	123.56	152.30	146.68	183.02	199.88	289.82
1-7/16	133.17	161.91	156.65	192.99	213.43	309.47
1-1/2	135.11	163.84	161.69	198.03	220.34	319.49
1-9/16	144.38	200.74	185.98	256.43	253.47	367.53
1-5/8	150.93	207.29	192.55	263.00	262.39	380.46
1-11/16	164.60	220.97	203.61	274.06	277.42	402.25
1-3/4	179.02	235.39	232.72	303.17	317.05	459.72
1-13/16	184.15	240.52	241.51	311.97	—	—
1-7/8	194.83	251.20	266.89	337.35	367.03	532.19
1-15/16	205.60	261.96	274.25	344.70	373.66	541.80
2	226.24	282.60	278.38	348.83	379.37	550.08
2-1/16	260.27	364.28	318.28	422.29	—	—

- ▶ LIST NO. 251M — 1" DEPTH OF CUT
- ▶ LIST NO. 252M — 2" DEPTH OF CUT

METRIC SIZES

Size	Price Each	
	List No. 251M	List No. 252M
14mm	46.53	64.97
16mm	50.31	72.22
18mm	54.09	79.90
20mm	57.87	83.69
22mm	64.15	95.66
24mm	69.20	101.98

Size	Price Each	
	List No. 251M	List No. 252M
25mm	72.00	105.00
26mm	74.23	108.24
28mm	79.30	118.34
30mm	84.33	128.42
32mm	98.18	141.02

TiN Coating available upon request. Please inquire.



SET NO. 251SA

7 Piece Set - 1" Cut
Contains 1 piece of each:
9/16, 11/16, 13/16, 15/16, 1", 1-1/16, 2"
Supplied in wood block.

SET PRICE — \$565.00

SET NO. 252SB

7 Piece Set - 2" Cut
Contains 1 piece of each:
9/16, 11/16, 13/16, 15/16, 1", 1-1/16, 2"
Supplied in wood block.

SET PRICE — \$772.00

▶ LIST NO. 251EP

EJECTOR - PILOT		
Size	Description	Price Each
1/4 x 3	Ejector - Pilot, Short	12.75
1/4 x 4	Ejector - Pilot, Long	19.02
1/4 x 5	Ejector - Pilot, X-Long	24.77

CHUCKING REAMERS

STRAIGHT SHANK

▶ LIST NO. 550 — STRAIGHT FLUTE



▶ LIST NO. 551 — SPIRAL FLUTE



LETTER SIZES

Size	Dec. Equiv.	Flute Length	Overall Length	Price Each	
				Straight List No. 550	Spiral List No. 551
A	.2340	1-1/2	6	23.11	26.50
B	.2380	1-1/2	6	23.11	26.50
C	.2420	1-1/2	6	23.11	26.50
D	.2460	1-1/2	6	23.11	26.50
E	.2500	1-1/2	6	18.91	21.00
F	.2570	1-1/2	6	23.11	26.50
G	.2610	1-1/2	6	24.56	28.25
H	.2660	1-1/2	6	25.96	29.85
I	.2720	1-1/2	6	25.96	29.85
J	.2770	1-1/2	6	25.96	29.85
K	.2810	1-1/2	6	25.96	29.85
L	.2900	1-1/2	6	25.96	29.85
M	.2950	1-1/2	6	25.96	29.85

Size	Dec. Equiv.	Flute Length	Overall Length	Price Each	
				Straight List No. 550	Spiral List No. 551
N	.3020	1-1/2	6	25.96	29.85
O	.3160	1-1/2	6	26.85	30.88
P	.3230	1-1/2	6	27.60	31.75
Q	.3320	1-1/2	6	27.60	31.75
R	.3390	1-1/2	6	27.60	31.75
S	.3480	1-3/4	7	27.60	31.75
T	.3580	1-3/4	7	27.60	31.75
U	.3680	1-3/4	7	27.60	31.75
V	.3770	1-3/4	7	30.75	35.35
W	.3860	1-3/4	7	30.75	35.35
X	.3970	1-3/4	7	30.75	35.35
Y	.4040	1-3/4	7	31.59	36.33
Z	.4130	1-3/4	7	31.59	36.33

▶ LIST NO. 550 — STRAIGHT FLUTE

▶ LIST NO. 551 — SPIRAL FLUTE

OVER AND UNDER SIZES — DOWEL PIN SIZES

Size	Flute Length	Overall Length	Price Each	
			Straight List No. 550	Spiral List No. 551
.0623	7/8	3-1/2	21.50	—
.0627	7/8	3-1/2	21.50	—
.0780	7/8	3-1/2	19.00	—
.0782	7/8	3-1/2	19.00	—
.1230	7/8	3-1/2	14.60	—
.1240	7/8	3-1/2	14.50	15.95
.1247	7/8	3-1/2	14.50	—
.1251	7/8	3-1/2	14.15	—
.1260	7/8	3-1/2	14.15	—
.1855	1-1/8	4-1/2	20.25	—
.1865	1-1/8	4-1/2	20.25	22.28
.1870	1-1/8	4-1/2	20.25	—
.1885	1-1/8	4-1/2	20.25	22.28
.2480	1-1/2	6	21.00	—
.2490	1-1/2	6	21.00	—
.2495	1-1/2	6	21.50	—
.2510	1-1/2	6	21.50	23.65
.3105	1-1/2	6	24.15	26.57
.3115	1-1/2	6	24.15	26.57
.3120	1-1/2	6	24.15	—
.3135	1-1/2	6	24.15	26.57
.3730	1-3/4	7	26.70	29.37

Size	Flute Length	Overall Length	Price Each	
			Straight List No. 550	Spiral List No. 551
.3740	1-3/4	7	26.70	—
.3745	1-3/4	7	26.70	—
.3760	1-3/4	7	26.70	28.60
.4355	1-3/4	7	29.50	—
.4365	1-3/4	7	29.50	32.45
.4370	1-3/4	7	29.50	—
.4385	1-3/4	7	29.50	32.45
.4980	2	8	33.00	—
.4990	2	8	33.00	36.30
.4995	2	8	33.00	—
.5010	2	8	33.00	36.30
.6230	2-1/4	9	63.50	—
.6240	2-1/4	9	63.50	—
.6245	2-1/4	9	63.50	—
.6260	2-1/4	9	63.50	—
.7480	2-1/2	9-1/2	81.20	—
.7490	2-1/2	9-1/2	73.50	—
.7510	2-1/2	9-1/2	73.50	—
.8740	2-5/8	10	94.60	—
.8760	2-5/8	10	94.60	—
.9980	2-3/4	10-1/2	118.25	—
.9990	2-3/4	10-1/2	118.25	—
1.0010	2-3/4	10-1/2	118.25	—

▶ LIST NO. 550M — STRAIGHT FLUTE



METRIC SIZES

Size	Dec. Equiv.	Price Each
0.75	.0295	17.50
1.00	.0394	17.50
1.15	.0453	17.50
1.90	.0748	17.50
2.00	.0787	14.20
2.10	.0827	16.50
2.40	.0945	16.50
2.50	.0984	14.20
2.75	.1083	14.20
2.80	.1102	14.20
3.00	.1181	14.20
3.50	.1378	16.95
4.00	.1575	16.95
4.50	.1772	20.00

Size	Dec. Equiv.	Price Each
5.00	.1969	21.50
5.30	.2087	23.00
5.50	.2165	21.50
6.00	.2362	23.50
6.50	.2559	23.50
7.00	.2756	25.95
7.50	.2953	25.95
8.00	.3150	26.85
8.50	.3346	27.60
9.00	.3543	27.60
9.50	.3740	26.70
10.00	.3937	30.75
10.50	.4134	29.00
11.00	.4331	29.75

Size	Dec. Equiv.	Price Each
11.50	.4528	34.75
12.00	.4724	36.00
12.50	.4921	37.00
13.00	.5118	38.00
13.50	.5315	38.00
14.00	.5512	38.00
14.50	.5709	42.50
15.00	.5906	42.50
15.50	.6102	48.75
16.00	.6299	48.75
16.50	.6496	48.75
17.00	.6693	48.75
17.50	.6890	56.00
18.00	.7087	56.00

Size	Dec. Equiv.	Price Each
18.50	.7283	56.00
19.00	.7480	56.00
19.50	.7677	62.75
20.00	.7874	62.75
20.50	.8071	62.75
21.00	.8268	71.50
21.50	.8465	71.50
22.00	.8661	71.50
22.50	.8858	78.75
23.00	.9055	78.75
23.50	.9252	78.75
24.00	.9449	88.75
24.50	.9646	88.75
25.00	.9843	88.75

CHUCKING REAMERS

SPECIAL DECIMAL SIZES

● LIST NO. 550D — STRAIGHT SHANK STRAIGHT FLUTE



Size	Price Each	Size	Price Each	Size	Price Each	Size	Price Each	Size	Price Each
.0305	21.90	.0985	19.40	.1365	22.80	.1707	22.00	.2080	24.39
.0325	21.90	.0992	19.40	.1370	22.80	.1710	22.00	.2085	24.39
.0340	21.90	.1005	19.40	.1375	22.80	.1715	22.00	.2095	24.39
.0355	21.90	.1010	19.40	.1377	22.80	.1720	22.00	.2100	24.39
.0365	21.90	.1017	19.40	.1380	22.80	.1725	22.00	.2105	24.39
.0405	21.10	.1025	19.40	.1385	22.80	.1727	22.00	.2110	24.39
.0415	21.10	.1045	19.40	.1390	22.80	.1735	22.00	.2115	24.39
.0425	21.10	.1050	19.40	.1395	22.80	.1740	22.00	.2120	24.39
.0435	21.10	.1055	19.40	.1397	22.80	.1745	22.00	.2125	24.39
.0470	21.10	.1057	19.40	.1400	22.80	.1750	22.00	.2135	24.39
.0475	21.10	.1067	19.40	.1402	22.80	.1755	22.00	.2140	24.39
.0490	21.10	.1070	19.40	.1410	21.00	.1760	22.00	.2145	24.39
.0495	21.10	.1075	19.40	.1415	21.00	.1765	22.00	.2150	24.39
.0500	21.10	.1082	19.40	.1420	21.00	.1775	22.00	.2155	24.39
.0505	21.10	.1084	19.40	.1421	21.00	.1780	22.00	.2160	24.39
.0510	21.10	.1097	17.00	.1425	21.00	.1785	22.00	.2170	24.39
.0525	21.10	.1107	17.00	.1427	21.00	.1790	22.00	.2175	24.39
.0535	21.10	.1112	17.00	.1430	21.00	.1795	22.00	.2180	24.39
.0540	21.10	.1115	17.00	.1432	21.00	.1800	22.00	.2185	24.39
.0545	21.10	.1120	17.00	.1435	21.00	.1805	22.00	.2190	24.39
.0555	21.10	.1125	17.00	.1445	21.00	.1810	22.00	.2195	24.39
.0560	21.10	.1132	17.00	.1450	21.00	.1815	22.00	.2200	24.39
.0565	21.10	.1155	17.00	.1455	21.00	.1822	22.00	.2205	24.39
.0575	21.10	.1175	17.00	.1460	21.00	.1825	22.00	.2215	24.39
.0590	21.10	.1180	17.00	.1465	21.00	.1830	22.00	.2220	24.39
.0613	21.10	.1185	17.00	.1475	21.00	.1832	22.00	.2225	24.39
.0622	21.10	.1190	17.00	.1480	21.00	.1835	22.00	.2230	24.39
.0632	19.30	.1192	17.00	.1485	21.00	.1845	22.00	.2235	24.39
.0637	19.30	.1195	17.00	.1490	21.00	.1860	22.00	.2240	24.39
.0662	19.30	.1200	17.00	.1500	21.00	.1862	24.81	.2242	24.39
.0667	19.30	.1205	17.00	.1505	21.00	.1863	24.81	.2245	24.39
.0680	19.35	.1210	17.00	.1510	21.00	.1872	24.81	.2250	24.39
.0682	19.35	.1215	17.00	.1512	21.00	.1877	24.81	.2255	24.39
.0702	19.35	.1220	17.00	.1515	21.00	.1882	24.81	.2260	24.39
.0722	19.35	.1225	17.00	.1525	21.00	.1885	24.81	.2265	24.39
.0727	19.35	.1227	17.00	.1530	21.00	.1897	24.81	.2270	24.39
.0755	19.35	.1235	17.00	.1535	21.00	.1900	24.81	.2275	24.39
.0757	19.35	.1243	17.00	.1545	21.00	.1905	24.81	.2285	24.39
.0767	19.35	.1244	17.00	.1550	21.00	.1915	24.81	.2290	24.39
.0777	19.35	.1245	17.00	.1552	21.00	.1920	24.81	.2295	24.39
.0790	19.40	.1248	17.00	.1555	21.00	.1925	24.81	.2300	24.39
.0792	19.40	.1249	17.00	.1557	21.00	.1927	24.81	.2305	24.39
.0802	19.40	.1253	17.00	.1580	21.00	.1930	24.81	.2310	24.39
.0805	19.40	.1255	22.80	.1582	22.00	.1933	24.81	.2312	24.39
.0812	19.40	.1258	22.80	.1583	22.00	.1937	24.81	.2315	24.39
.0815	19.40	.1265	22.80	.1585	22.00	.1940	24.81	.2320	24.39
.0822	19.40	.1267	22.80	.1595	22.00	.1942	24.81	.2325	22.74
.0826	19.40	.1268	22.80	.1600	22.00	.1945	24.81	.2330	22.74
.0845	19.40	.1270	22.80	.1605	22.00	.1950	24.81	.2335	22.74
.0867	19.40	.1275	22.80	.1615	22.00	.1955	24.81	.2340	22.74
.0875	19.40	.1277	22.80	.1620	22.00	.1965	24.81	.2350	22.74
.0880	19.40	.1280	22.80	.1625	22.00	.1975	24.81	.2352	22.74
.0887	19.40	.1290	22.80	.1630	22.00	.1980	24.81	.2355	22.74
.0902	19.40	.1295	22.80	.1635	22.00	.1985	24.81	.2360	22.74
.0912	19.40	.1297	22.80	.1640	22.00	.1995	24.81	.2365	22.74
.0915	19.40	.1300	22.80	.1645	22.00	.2005	24.81	.2370	22.74
.0918	19.40	.1305	22.80	.1650	22.00	.2015	24.81	.2375	22.74
.0920	19.40	.1310	22.80	.1655	22.00	.2020	24.81	.2385	22.74
.0922	19.40	.1315	22.80	.1665	22.00	.2025	24.81	.2390	22.74
.0930	19.40	.1320	22.80	.1670	22.00	.2030	24.81	.2395	22.74
.0950	19.40	.1322	22.80	.1675	22.00	.2035	24.39	.2400	22.74
.0952	19.40	.1325	22.80	.1680	22.00	.2045	24.39	.2405	22.74
.0957	19.40	.1335	22.80	.1685	22.00	.2050	24.39	.2410	22.74
.0962	19.40	.1340	22.80	.1690	22.00	.2060	24.39	.2415	22.74
.0964	19.40	.1345	22.80	.1695	22.00	.2065	24.39	.2425	22.74
.0970	19.40	.1350	22.80	.1700	22.00	.2070	24.39	.2430	22.74
.0971	19.40	.1355	22.80	.1705	22.00	.2075	24.39	.2435	22.74

COBALT CHUCKING REAMERS

STRAIGHT SHANK

● LIST NO. 550C — STRAIGHT FLUTE



For reaming high alloy steels, titanium, stainless and other difficult to machine materials.

Size	Dec. Equiv.	Flute Length	Overall Length	Price Each
1/16	.0625	1/2	2-1/2	16.69
5/64	.0781	3/4	3	13.49
3/32	.0938	3/4	3	13.49
7/64	.1094	7/8	3-1/2	14.03
1/8	.1250	7/8	3-1/2	11.20
9/64	.1406	1	4	16.75
5/32	.1562	1	4	15.05
11/64	.1719	1-1/8	4-1/2	17.82
3/16	.1875	1-1/8	4-1/2	16.10
13/64	.2031	1-1/4	5	21.65
7/32	.2188	1-1/4	5	21.65
15/64	.2344	1-1/2	6	22.28
1/4	.2500	1-1/2	6	19.00
17/64	.2656	1-1/2	6	30.32
9/32	.2812	1-1/2	6	28.80

Size	Dec. Equiv.	Flute Length	Overall Length	Price Each
19/64	.2969	1-1/2	6	30.30
5/16	.3125	1-1/2	6	27.32
21/64	.3281	1-1/2	6	32.65
11/32	.3438	1-1/2	6	32.65
23/64	.3594	1-3/4	7	33.20
3/8	.3750	1-3/4	7	29.93
25/64	.3906	1-3/4	7	39.10
13/32	.4062	1-3/4	7	39.10
27/64	.4219	1-3/4	7	39.10
7/16	.4375	1-3/4	7	38.50
29/64	.4531	1-3/4	7	46.45
15/32	.4688	1-3/4	7	46.45
31/64	.4844	2	8	46.45
1/2	.5000	2	8	44.08
17/32	.5312	2	8	52.10

Size	Dec. Equiv.	Flute Length	Overall Length	Price Each
9/16	.5625	2	8	52.10
19/32	.5938	2	8	52.10
5/8	.6250	2-1/4	9	60.80
21/32	.6562	2-1/4	9	68.73
11/16	.6875	2-1/4	9	68.73
23/32	.7188	2-1/4	9	76.75
3/4	.7500	2-1/2	9-1/2	77.15
25/32	.7812	2-1/2	9-1/2	83.20
13/16	.8125	2-1/2	9-1/2	83.20
27/32	.8438	2-1/2	9-1/2	98.45
7/8	.8750	2-5/8	10	100.75
29/32	.9062	2-5/8	10	108.52
15/16	.9375	2-5/8	10	108.52
31/32	.9688	2-5/8	10	121.60
1	1.000	2-3/4	10-1/2	122.76



CARBIDE TIPPED CHUCKING REAMERS

STRAIGHT SHANK

● LIST NO. CT550 — STRAIGHT FLUTE



For hole reaming in cast iron, heat treated steels and other hard materials.

Size	Dec. Equiv.	Flute Length	Overall Length	Price Each
3/16	.1875	1-1/8	4-1/2	55.58
13/64	.2031	1-1/4	5	55.58
7/32	.2188	1-1/4	5	55.58
15/64	.2344	1-1/2	6	55.58
1/4	.2500	1-1/2	6	55.58
17/64	.2656	1-1/2	6	56.90
9/32	.2812	1-1/2	6	56.90
19/64	.2969	1-1/2	6	56.90
5/16	.3125	1-1/2	6	56.90
21/64	.3281	1-1/2	6	58.89
11/32	.3438	1-1/2	6	58.89
23/64	.3594	1-3/4	7	58.95
3/8	.3750	1-3/4	7	58.95

Size	Dec. Equiv.	Flute Length	Overall Length	Price Each
25/64	.3906	1-3/4	7	61.65
13/32	.4062	1-3/4	7	61.65
27/64	.4219	1-3/4	7	65.72
7/16	.4375	1-3/4	7	65.72
29/64	.4531	1-3/4	7	66.95
15/32	.4688	1-3/4	7	66.95
31/64	.4844	2	8	72.25
1/2	.5000	2	8	72.36
17/32	.5312	2	8	74.25
9/16	.5625	2	8	74.34
19/32	.5938	2	8	77.10
5/8	.6250	2-1/4	9	77.20
21/32	.6562	2-1/4	9	78.55

Size	Dec. Equiv.	Flute Length	Overall Length	Price Each
11/16	.6875	2-1/4	9	78.54
3/4	.7500	2-1/2	9-1/2	82.20
13/16	.8125	2-1/2	9-1/2	84.95
7/8	.8750	2-5/8	10	88.27
15/16	.9375	2-5/8	10	102.95
1	1.0000	2-3/4	10-1/2	107.94
1-1/16	1.0625	2-3/4	10-1/2	116.24
1-1/8	1.1250	2-7/8	11	125.83
1-3/16	1.1875	2-7/8	11	132.25
1-1/4	1.2500	3	11-1/2	139.66
1-5/16	1.3125	3	11-1/2	147.18
1-3/8	1.3750	3-1/4	12	156.00
1-1/2	1.5000	3-1/2	12-1/2	182.60



SOLID CARBIDE CHUCKING REAMERS

STRAIGHT SHANK

■ LIST NO. C805 — STRAIGHT FLUTE



Size	Dec. Equiv.	Flute Length	Overall Length	Price Each
1/16	.0625	3/8	1-1/2	15.20
5/64	.0781	1/2	1-3/4	15.65
3/32	.0938	1/2	2	17.55
7/64	.1094	5/8	2-1/4	19.95
1/8	.1250	5/8	2-1/4	21.30
9/64	.1406	3/4	2-1/4	23.75
5/32	.1562	3/4	2-1/2	25.55
11/64	.1719	7/8	2-3/4	27.90

Size	Dec. Equiv.	Flute Length	Overall Length	Price Each
3/16	.1875	7/8	2-3/4	29.70
13/64	.2031	1	3	32.35
7/32	.2188	1	3	35.66
15/64	.2344	1	3	38.20
1/4	.2500	1	3	40.95
17/64	.2656	1-1/8	3-1/4	41.75
9/32	.2812	1-1/8	3-1/4	44.78
19/64	.2969	1-1/8	3-1/4	46.90

Size	Dec. Equiv.	Flute Length	Overall Length	Price Each
5/16	.3125	1-1/8	3-1/4	49.92
21/64	.3281	1-1/4	3-1/2	52.35
11/32	.3438	1-1/4	3-1/2	56.50
23/64	.3594	1-1/4	3-1/2	60.05
3/8	.3750	1-1/4	3-1/2	65.48
13/32	.4062	1-1/4	3-1/2	79.00
7/16	.4375	1-3/8	4	88.00
1/2	.5000	1-1/2	4	113.50

JOBBER'S REAMERS

TAPER SHANK

- ▶ LIST NO. 578 — STRAIGHT FLUTE
- ▶ LIST NO. 579 — SPIRAL FLUTE



For use in all types of materials where a long flute is required.

Size	Dec. Equiv.	Flute Length	Overall Length	Morse Taper No.	Price Each	
					List No. 578	List No. 579
1/4	.2500	2	5-3/16	1	54.55	62.73
9/32	.2812	2	5-3/16	1	57.45	—
5/16	.3125	2-1/4	5-1/2	1	56.80	65.32
11/32	.3438	2-1/4	5-1/2	1	60.43	—
3/8	.3750	2-1/2	5-13/16	1	65.71	—
13/32	.4062	2-1/2	5-13/16	1	68.58	—
7/16	.4375	2-3/4	6-1/8	1	74.20	85.33
15/32	.4688	2-3/4	6-1/8	1	69.32	—
1/2	.5000	3	6-7/16	1	74.20	85.33
17/32	.5312	3	6-7/16	1	76.61	—
9/16	.5625	3-1/4	6-3/4	1	84.00	—
19/32	.5938	3-1/4	6-3/4	1	85.90	—
5/8	.6250	3-1/2	7-9/16	2	87.52	—
21/32	.6562	3-1/2	7-9/16	2	92.98	110.38
11/16	.6875	3-7/8	8	2	102.00	117.30
23/32	.7188	3-7/8	8	2	84.39	—

Size	Dec. Equiv.	Flute Length	Overall Length	Morse Taper No.	Price Each	
					List No. 578	List No. 579
3/4	.7500	4-3/16	8-3/8	2	102.00	117.30
25/32	.7812	4-3/16	8-3/8	2	96.64	—
13/16	.8125	4-9/16	8-13/16	2	114.55	131.73
27/32	.8438	4-7/8	9-13/16	2	103.98	—
7/8	.8750	4-7/8	9-13/16	2	128.20	—
15/16	.9375	5-1/8	10	3	135.00	—
1	1.0000	5-7/16	10-3/8	3	146.60	177.96
1-1/16	1.0625	5-5/8	10-5/8	3	155.95	—
1-1/8	1.1250	5-13/16	10-7/8	3	175.10	190.00
1-3/16	1.1875	6	11-1/8	3	195.00	205.00
1-1/4	1.2500	6-1/8	12-9/16	4	200.00	—
1-5/16	1.3125	6-1/4	12-11/16	4	210.00	—
1-3/8	1.3750	6-5/16	12-13/16	4	225.00	—
1-7/16	1.4375	6-7/16	13	4	280.45	—
1-1/2	1.5000	6-1/2	13-1/8	4	248.00	285.20

HIGH SPEED STEEL

TAPER PIPE REAMERS

For reaming holes to be tapped with taper pipe taps.
These reamers are tapered 3/4" to the foot.

- ▶ LIST NO. 566 — STRAIGHT FLUTE

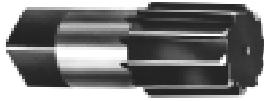

- ▶ LIST NO. 567 — SPIRAL FLUTE



Size	Diameter		Flute Length	Overall Length	Shank Size	Price Each	
	Small End	Large End				List No. 566	List No. 567
1/16	.2450	.2910	3/4	2	—	59.00	59.00
1/8	.3160	.3620	3/4	2-1/8	.4375	41.50	48.00
1/4	.4060	.4720	1-1/16	2-7/16	.5625	47.00	55.00
3/8	.5400	.6060	1-1/16	2-9/16	.7000	53.40	62.80
1/2	.6650	.7510	1-3/8	3-1/8	.6875	67.50	79.25
3/4	.8760	.9620	1-3/8	3-1/4	.9063	71.50	110.00
1	1.1030	1.2120	1-3/4	3-3/4	1.1250	133.45	156.85
1-1/4	1.4440	1.5530	1-3/4	4	1.3125	200.60	235.90
1-1/2	1.6840	1.7930	1-3/4	4-1/4	1.5000	253.30	298.00
2	2.1590	2.2680	1-3/4	4-1/2	1.8750	338.00	398.00
2-1/2	2.5610	2.7220	2-5/8	5-1/2	2.2050	607.50	675.00
3	3.2020	3.3800	2-3/4	6	2.6250	796.00	885.00

HIGH SPEED STEEL

TAPER PIN REAMERS

- ▶ LIST NO. 556 — STRAIGHT FLUTE



For reaming in mild steel.

- ▶ LIST NO. 557 — SPIRAL FLUTE



For reaming in lower ranges of BHN hardness.

- ▶ LIST NO. 558 — HELICAL FLUTE



For machine reaming of holes for taper pins.
High helix flute design eases chip ejection.

Size	Diameter		Flute Length	Overall Length	Shank Size	Price Each		
	Small End	Large End				List No. 556	List No. 557	List No. 558
7/0	.0497	.0666	13/16	1-13/16	5/64	39.00	40.80	36.38
6/0	.0611	.0806	15/16	1-15/16	3/32	39.00	40.80	34.00
5/0	.0719	.0966	1-3/16	2-3/16	7/64	35.78	39.00	35.20
4/0	.0869	.1142	1-5/16	2-5/16	1/8	35.78	39.00	35.20
3/0	.1029	.1302	1-5/16	2-5/16	9/64	35.78	39.00	31.70
2/0	.1137	.1462	1-9/16	2-9/16	5/32	32.00	34.00	30.55
0	.1287	.1638	1-11/16	2-15/16	11/64	30.60	33.00	31.85
1	.1447	.1798	1-11/16	2-15/16	3/16	30.00	33.20	33.60
2	.1605	.2008	1-15/16	3-3/16	13/64	30.00	33.50	38.20
3	.1813	.2294	2-5/16	3-11/16	15/64	30.00	33.50	39.45
4	.2071	.2604	2-9/16	4-1/16	17/64	33.20	36.15	48.00
5	.2409	.2994	2-13/16	4-5/16	5/16	35.75	39.00	51.23
6	.2773	.3540	3-11/16	5-7/16	23/64	43.15	47.75	60.25
7	.3297	.4220	4-7/16	6-5/16	13/32	55.30	60.20	72.36
8	.3971	.5050	5-3/16	7-3/16	7/16	71.00	77.80	84.00
9	.4805	.6066	6-1/16	8-5/16	9/16	86.40	94.00	90.15
10	.5799	.7216	6-13/16	9-5/16	5/8	95.00	104.23	120.00
11	.7060	.8780	8-1/4	11-1/4	11/16	204.00	238.00	265.00
12	.8420	1.0500	10	13-5/8	3/4	280.00	289.00	315.00
13	1.0090	1.2590	12	16	1-1/16	446.00	476.00	586.00
14	1.2500	1.5420	14	18-1/4	1-3/8	665.00	704.00	779.00

SHELL REAMERS

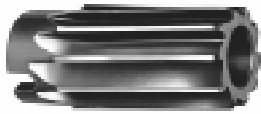

- ▶ LIST NO. 560 — STRAIGHT FLUTE
- ▶ LIST NO. 561 — SPIRAL FLUTE



To be used with shell reamer arbors, listed below. One size arbor fits a range of sizes.

Size	Overall Length	Hole Diameter	Price Each	
			Straight List No. 560	Spiral List No. 561
3/4	2-1/4	3/8	93.00	107.00
13/16	2-1/2	1/2	97.20	112.00
7/8	2-1/2	1/2	99.00	115.00
29/32	2-1/2	1/2	109.50	—
15/16	2-1/2	1/2	102.50	119.00
1	2-1/2	1/2	105.00	122.35
1-1/64	2-3/4	5/8	117.50	—
1-1/16	2-3/4	5/8	113.70	131.50
1-3/32	2-3/4	5/8	125.00	—
1-1/8	2-3/4	5/8	120.57	137.00
1-3/16	2-3/4	5/8	125.00	142.50
1-1/4	2-3/4	5/8	127.00	147.95
1-9/32	3	5/8	145.80	—
1-5/16	3	3/4	134.60	154.30
1-11/32	3	3/4	157.00	—
1-3/8	3	3/4	143.25	163.60
1-13/32	3	3/4	158.00	—
1-7/16	3	3/4	157.30	173.00
1-15/32	3	3/4	169.77	—
1-1/2	3	3/4	159.50	182.90
1-9/16	3	3/4	176.12	205.00
1-19/32	3	3/4	195.00	—
1-5/8	3	3/4	188.35	223.65
1-21/32	3-1/2	1	195.00	—
1-11/16	3-1/2	1	206.90	245.60
1-3/4	3-1/2	1	219.50	259.75
1-23/32	3-1/2	1	248.00	—
1-13/16	3-1/2	1	234.00	278.28
1-25/32	3-1/2	1	255.00	—
1-27/32	3-1/2	1	270.00	—
1-7/8	3-1/2	1	249.50	295.00
1-29/32	3-1/2	1	295.00	—
1-15/16	3-1/2	1	265.00	314.60
1-31/32	3-1/2	1	278.00	—

Size	Overall Length	Hole Diameter	Price Each	
			Straight List No. 560	Spiral List No. 561
2	3-1/2	1	275.00	323.50
2-1/16	3-3/4	1-1/4	291.60	353.20
2-1/8	3-3/4	1-1/4	314.60	370.32
2-3/16	3-3/4	1-1/4	330.75	394.09
2-1/4	3-3/4	1-1/4	345.30	405.00
2-5/16	3-3/4	1-1/4	355.00	440.00
2-3/8	3-3/4	1-1/4	363.00	445.50
2-7/16	3-3/4	1-1/4	406.35	477.00
2-1/2	3-3/4	1-1/4	414.50	477.00
2-9/16	4	1-1/2	432.00	479.00
2-5/8	4	1-1/2	460.00	496.80
2-11/16	4	1-1/2	488.70	514.35
2-3/4	4	1-1/2	513.00	557.50
2-13/16	4	1-1/2	542.70	599.00
2-7/8	4	1-1/2	573.75	619.60
2-15/16	4	1-1/2	605.50	650.00
3	4	1-1/2	635.85	685.80
3-1/16	4-1/2	1-3/4	805.95	835.65
3-1/8	4-1/2	1-3/4	974.70	985.00
3-3/16	4-1/2	1-3/4	1007.00	1037.00
3-1/4	4-1/2	1-3/4	1039.50	1088.00
3-5/16	4-1/2	1-3/4	1075.00	1127.00
3-3/8	4-1/2	1-3/4	1111.00	1167.75
3-7/16	4-1/2	1-3/4	1143.50	1200.00
3-1/2	4-1/2	1-3/4	1174.50	1232.50
3-9/16	5	2	1206.00	1264.95
3-5/8	5	2	1235.00	1296.00
3-11/16	5	2	1266.00	1329.75
3-3/4	5	2	1300.00	1362.00
3-13/16	5	2	1350.00	1413.00
3-7/8	5	2	1396.00	1465.00
3-15/16	5	2	1438.00	1511.00
4	5	2	1485.00	1557.00

▶ SHELL REAMER ARBORS

STRAIGHT SHANK



TAPER SHANK



HARDENED AND GROUND

Size	Fits Reamer Sizes		Arbor Dia.	Overall Length	Straight Shank			Taper Shank		
	Smallest	Largest			Shank Size	Tool No.	Price Each	Morse Taper No.	Tool No.	Price Each
4	21/32	25/32	3/8	9	1/2	SR4S	78.00	2	SR4T	93.00
5	13/16	1-1/32	1/2	9-1/2	5/8	SR5S	87.00	2	SR5T	111.00
6	1-1/16	1-9/32	5/8	10	3/4	SR6S	96.00	3	SR6T	120.00
7	1-5/16	1-21/32	3/4	11	7/8	SR7S	105.00	3	SR7T	132.00
8	1-11/16	2	1	12	1-1/8	SR8S	117.00	4	SR8T	147.00
9	2-1/16	2-1/2	1-1/4	13	1-3/8	SR9S	141.00	4	SR9T	165.00
10	2-9/16	3	1-1/2	14	1-5/8	SR10S	181.00	5	SR10T	189.00
11	3-1/16	3-1/2	1-3/4	15	2	SR11S	255.00	5	SR11T	265.00
12	3-9/16	4	2	16	2-1/8	SR12S	357.00	5	SR12T	369.00

HAND EXPANSION REAMERS

► LIST NO. 576 — STRAIGHT FLUTE



► LIST NO. 577 — SPIRAL FLUTE



Recommended Expansion Limits:		
Sizes	1/4 to 21/32	.010
Sizes	11/16 to 1	.013
Sizes	1-1/16 to 1-1/2	.015
Sizes	1-9/16 to 2	.017

These reamers are used to enlarge holes by a few thousandths. The pilots and guides of these reamers are ground under size to allow smooth entrance. The spiral flute style is especially suited for use in holes where the cut is interrupted by a longitudinal slot or keyway.

Size	Dec. Equiv.	Flute Length	Overall Length	Price Each	
				List No. 576	List No. 577
1/4	.2500	1-7/16	4-1/4	85.00	89.25
5/16	.3125	1-3/4	4-1/2	87.00	91.98
3/8	.3750	1-3/4	5	99.50	103.95
13/32	.4062	1-3/4	5	102.30	107.40
7/16	.4375	1-3/4	5	103.95	109.15
15/32	.4688	1-13/16	5-1/2	105.45	110.72
1/2	.5000	1-13/16	5-1/2	104.40	109.62
17/32	.5312	2-1/8	6	110.70	116.24
9/16	.5625	2-1/8	6	114.00	119.70
5/8	.6250	2-1/2	6-1/2	123.50	129.15
11/16	.6875	2-1/2	6-3/4	141.00	148.05
3/4	.7500	2-11/16	7-1/16	156.00	163.80
13/16	.8125	3-1/16	7-9/16	175.50	184.28
7/8	.8750	3-5/16	8	189.00	198.45
15/16	.9375	3-9/16	8-3/8	216.00	226.80

Size	Dec. Equiv.	Flute Length	Overall Length	Price Each	
				List No. 576	List No. 577
1	1.0000	3-3/4	8-7/8	230.00	241.50
1-1/16	1.0625	4	9-3/16	240.00	252.00
1-1/8	1.1250	4-1/8	9-1/2	260.00	273.00
1-3/16	1.1875	4-1/4	9-7/8	265.00	278.25
1-1/4	1.2500	4-3/8	10-1/4	272.00	285.60
1-5/16	1.3125	4-1/2	10-5/8	285.00	299.25
1-3/8	1.3750	4-9/16	11	310.00	325.50
1-7/16	1.4375	4-3/4	11-3/8	340.00	357.00
1-1/2	1.5000	4-13/16	11-5/8	390.00	409.50
1-9/16	1.5625	4-13/16	11-7/8	411.00	431.55
1-5/8	1.6250	4-7/8	12	422.00	443.10
1-3/4	1.7500	5	12-3/8	486.00	510.30
1-7/8	1.8750	5	12-3/4	530.00	556.50
2	2.0000	5	13-1/16	620.00	651.00

SETS

SET NO. 576S

5 Piece Straight Flute Set
 Contains 1 Piece of Each:
 1/4, 3/8, 1/2, 5/8, 3/4
 Supplied in wood block
SET PRICE — \$575.00

SET NO. 577S

5 Piece Spiral Flute Set
 Contains 1 Piece of Each:
 1/4, 3/8, 1/2, 5/8, 3/4
 Supplied in wood block
SET PRICE — \$599.00

ADJUSTABLE HAND REAMERS

► LIST NO. 570



Blades are adjusted by loosening one nut and tightening the other. Each reamer expands to the next size.

Size	Range of Adjustment	Blade Length	Overall Length	Price Each
8/A	1/4 to 9/32	1-11/32	3-1/4	58.92
7/A	9/32 to 5/16	1-11/32	3-1/2	58.92
6/A	5/16 to 11/32	1-1/2	4-1/8	58.92
5/A	11/32 to 3/8	1-1/2	4-3/8	58.92
4/A	3/8 to 13/32	1-1/2	4-3/4	60.90
3/A	13/32 to 7/16	1-1/2	5	67.40
2/A	7/16 to 15/32	1-5/8	5-1/4	67.40
A	15/32 to 17/32	1-5/8	5-1/2	71.44
B	17/32 to 19/32	1-13/16	5-3/4	71.44
C	19/32 to 21/32	2-1/16	6-1/2	74.33
D	21/32 to 23/32	2-3/16	6-3/4	77.81

Size	Range of Adjustment	Blade Length	Overall Length	Price Each
E	23/32 to 25/32	2-1/2	7	81.92
F	25/32 to 27/32	2-5/8	7-3/8	84.55
G	27/32 to 15/16	3	8	88.76
H	15/16 to 1-1/16	3-1/4	9	93.64
I	1-1/16 to 1-3/16	3-3/8	10	114.35
J	1-3/16 to 1-11/32	3-7/8	11	135.40
K	1-11/32 to 1-1/2	4-1/4	12	175.88
L	1-1/2 to 1-13/16	4-7/16	14	214.40
M	1-13/16 to 2-7/32	5	16	272.17
N	2-7/32 to 2-3/4	4-13/16	18	479.38
O	2-3/4 to 3-11/32	5-3/16	20	659.20

SETS

SET NO. 570A

8 Piece Set
 Contains 1 Piece of Each:
 A thru H.
 Supplied in wood case.
SET PRICE — \$649.99

SET NO. 570B

4 Piece Set
 Contains 1 Piece of Each:
 8A thru 5A.
 Supplied in wood case.
SET PRICE — \$249.00

SET NO. 570C

11 Piece Set
 Contains 1 Piece of Each:
 A thru K.
 Supplied in wood case.
SET PRICE — \$1075.00

HAND REAMERS

► LIST NO. 564 — STRAIGHT FLUTE



► LIST NO. 565 — SPIRAL FLUTE



For finishing of holes by hand. Square end can be held in a vise wrench or tap wrench. Spiral flute style drives chips forward.

Size	Dec. Equiv.	Flute Length	Overall Length	Price Each	
				List No. 564	List No. 565
3/64	.0469	1	2	41.95	45.98
1/16	.0625	1	2	41.95	45.98
5/64	.0781	1	2	41.95	45.98
3/32	.0938	1-1/4	2-1/2	41.95	45.98
7/64	.1094	1-1/4	2-1/2	41.95	45.98
1/8	.1250	1-1/2	3	38.50	46.20
9/64	.1406	1-5/8	3-1/4	43.70	46.20
5/32	.1560	1-5/8	3-1/4	43.70	46.20
11/64	.1719	1-3/4	3-1/2	43.70	—
3/16	.1875	1-3/4	3-1/2	41.21	48.16
7/32	.2188	1-7/8	3-3/4	46.20	50.00
15/64	.2344	2	4	46.20	50.00
1/4	.2500	2	4	43.85	50.00
9/32	.2812	2-1/8	4-1/4	49.50	58.25
19/64	.2969	2-1/4	4-1/2	49.50	—
5/16	.3125	2-1/4	4-1/2	47.95	55.00
11/32	.3438	2-3/8	4-3/4	57.85	65.45
23/64	.3594	2-1/2	5	57.85	65.45
3/8	.3750	2-1/2	5	55.00	62.00
25/64	.3906	2-5/8	5-1/4	62.80	65.00
13/32	.4062	2-5/8	5-1/4	62.80	71.75
27/64	.4219	2-3/4	5-1/2	62.80	71.75
7/16	.4375	2-3/4	5-1/2	62.80	68.85
29/64	.4531	2-7/8	5-3/4	69.50	77.70
15/32	.4688	2-7/8	5-3/4	69.50	77.70
31/64	.4844	3	6	69.50	77.70
1/2	.5000	3	6	67.00	73.90
17/32	.5312	3-1/8	6-1/4	76.75	86.65
35/64	.5469	3-1/4	6-1/2	76.75	86.85
9/16	.5625	3-1/4	6-1/2	76.75	86.65
37/64	.5781	3-3/8	6-3/4	87.95	96.50
19/32	.5938	3-3/8	6-3/4	87.95	96.50
39/64	.6094	3-1/2	7	87.95	96.50
5/8	.6250	3-1/2	7	82.90	92.50
41/64	.6406	3-11/16	7-3/8	82.90	92.50

Size	Dec. Equiv.	Flute Length	Overall Length	Price Each	
				List No. 564	List No. 565
21/32	.6562	3-11/16	7-3/8	96.30	106.00
43/64	.6719	3-7/8	7-3/4	96.30	106.00
11/16	.6875	3-7/8	7-3/4	96.30	106.00
45/64	.7031	4-1/16	8-1/8	90.95	101.00
23/32	.7188	4-1/16	8-1/8	102.20	105.65
47/64	.7344	4-3/16	8-3/8	—	105.65
3/4	.7500	4-3/16	8-3/8	102.20	107.00
49/64	.7656	4-3/16	8-3/8	—	107.00
25/32	.7812	4-3/8	8-3/4	102.20	107.00
51/64	.7969	4-9/16	9-1/8	119.65	126.50
13/16	.8125	4-9/16	9-1/8	117.65	126.50
53/64	.8281	4-9/16	9-1/8	117.65	126.50
27/32	.8438	4-11/16	9-3/8	117.65	126.50
7/8	.8750	4-7/8	9-3/4	117.65	126.50
57/64	.8906	5	10	117.65	126.50
29/32	.9062	5	10	133.00	141.95
59/64	.9219	5-1/8	10-1/4	133.00	141.95
15/16	.9375	5-1/8	10-1/4	133.00	141.95
31/32	.9688	5-5/16	10-3/8	135.00	141.95
1	1.0000	5-7/16	10-7/8	133.00	141.95
1-1/16	1.0625	5-5/8	11-1/4	142.50	156.00
1-1/8	1.1250	5-13/16	11-5/8	174.50	191.00
1-3/16	1.1875	6	12	176.85	191.00
1-1/4	1.2500	6-1/8	12-1/4	211.40	235.00
1-5/16	1.3125	6-1/4	12-1/2	217.30	235.00
1-3/8	1.3750	6-5/16	12-5/8	250.50	268.80
1-7/16	1.4375	6-7/16	12-7/8	256.70	277.80
1-1/2	1.5000	6-1/2	13	295.40	322.00
1-19/32	1.5938	6-1/2	13	300.00	—
1-11/16	1.6875	6-3/4	13-1/2	303.25	328.75
1-3/4	1.7500	6-3/4	13-1/2	499.00	—
1-13/16	1.8125	7	13-3/4	499.00	—
1-15/16	1.9375	7	14	499.00	—
2	2.0000	7	14	650.00	—
2-1/2	2.5000	7-1/2	15	825.00	—

SET NO. 564S

5 Piece Set
 Contains 1 Piece of Each:
 1/4, 3/8, 1/2, 5/8, 3/4
 Supplied in Wood Stand.
SET PRICE — \$349.00

SET NO. 565S

5 Piece Set
 Contains 1 Piece of Each:
 1/4, 3/8, 1/2, 5/8, 3/4
 Supplied in Wood Stand.
SET PRICE — \$384.99

METRIC HAND REAMERS

► LIST NO. 564M — STRAIGHT FLUTE



Size	Dec. Equiv.	Flute Length	Overall Length	Price Each
3.00	.1181	1-7/32	2-7/16	43.70
3.20	.1260	1-1/4	2-1/2	43.70
3.50	.1378	1-3/8	2-3/4	43.70
4.00	.1575	1-1/2	3	43.70
4.50	.1772	1-5/8	3-1/4	43.70
5.00	.1969	1-3/4	3-1/2	46.20
5.50	.2165	1-13/16	3-5/8	46.20
6.00	.2362	1-13/16	3-5/8	46.20
7.00	.2756	2-1/8	4-1/4	49.50
8.00	.3150	2-1/4	4-1/2	57.85
9.00	.3543	2-7/16	4-7/8	57.85

Size	Dec. Equiv.	Flute Length	Overall Length	Price Each
10.00	.3937	2-5/8	5-1/4	62.80
11.00	.4331	2-3/4	5-1/2	62.80
12.00	.4724	3	6	69.50
13.00	.5118	3	6	76.75
14.00	.5512	3-1/4	6-1/2	76.75
15.00	.5906	3-1/4	6-1/2	87.95
16.00	.6299	3-1/2	6-7/8	96.30
17.00	.6693	3-3/8	6-3/4	96.30
18.00	.7087	3-11/16	7-1/2	102.20
19.00	.7480	3-3/4	7-1/2	117.65
20.00	.7874	4	8	117.65



HIGH SPEED STEEL

BRIDGE REAMERS

TAPER SHANK — LONG BODY

Bridge reamers are designed to ream off-size, mis-shaped or mis-aligned holes in structural iron or steel. They are popular in the bridge erection and ship construction industries and in other similar applications.

Size	Approx. Point Size	No. of Flutes	Flute Length	Overall Length	Morse Taper No.	Price Each	
						Spiral List No. 532	Straight List No. 533
9/32	5/32	4	4	7-1/4	1	57.50	—
11/32	5/32	4	4	7-1/4	2	57.50	—
7/16	1/4	5	4-3/8	8-1/4	2	57.50	65.00
15/32	1/4	5	5-1/8	9	2	61.25	—
1/2	9/32	5	5-1/8	9	2	61.25	65.00
33/64	9/32	5	5-1/8	9	2	63.15	85.00
17/32	9/32	5	5-1/8	9	2	63.15	—
9/16	11/32	5	5-1/8	9	2	64.15	79.50
37/64	3/8	5	5-1/8	9	2	67.50	79.50
5/8	3/8	5	6-1/8	10	2	72.50	79.50
11/16	25/64	5	7-1/8	11-3/4	3	87.00	99.00
3/4	7/16	5	7-3/8	12	3	95.00	99.00
25/32	1/2	5	7-3/8	12	3	105.00	—
13/16	1/2	5	7-3/8	12	3	113.85	107.00
7/8	9/16	5	7-3/8	12	3	113.85	121.00
29/32	5/8	5	7-3/8	12	3	125.00	—
15/16	5/8	5	7-3/8	12	3	112.00	121.00
1	11/16	5	7-3/8	12	3	128.00	139.50
1-1/32	3/4	5	7-3/8	12	3	142.00	—
1-1/16	3/4	5	7-3/8	12	3	140.75	175.00
1-1/8	13/16	5	7-3/8	12	3	155.00	175.00
1-5/32	7/8	5	7-3/8	12	3	165.00	—
1-3/16	7/8	5	7-3/8	12	3	175.00	178.00
1-7/32	15/16	4	7-3/8	13	4	189.00	—
1-1/4	15/16	5	7-3/8	13	4	193.00	214.00
1-9/32	1	5	7-3/8	13	4	233.00	—
1-5/16	1	5	7-3/8	13	4	223.00	235.00
1-11/32	1-1/8	4	7-3/8	13	4	245.00	—
1-3/8	1-1/8	5	7-3/8	13	4	253.50	265.00
1-13/32	1-3/16	4	7-3/8	13	4	260.00	—
1-7/16	1-3/16	5	7-3/8	13	4	265.00	278.00
1-1/2	1-1/4	5	7-3/8	13	4	297.00	310.00
1-17/32	1-3/8	4	7-3/8	13	4	375.00	—
1-9/16	1-3/8	4	7-3/8	13	4	390.00	398.00
1-5/8	1-3/8	5	7-3/8	13	4	399.00	405.00
1-11/16	1-11/16	5	7-3/8	13	4	425.00	—
1-3/4	1-11/16	5	7-3/8	13	5	450.00	—
1-7/8	1-11/16	4	7-3/8	13	5	475.00	480.00
2	1-11/16	6	7-3/8	13	5	499.00	—

Additional sizes available from stock. Please inquire.

▶ LIST NO. 532 — TYPE "D" SPIRAL FLUTE



▶ LIST NO. 533 — TYPE "C" STRAIGHT FLUTE



HIGH SPEED STEEL

CAR REAMERS

TAPER SHANK — SHORT BODY

Car reamers are primarily used for enlarging, aligning and deburring holes. They are often used in building and repairing railroad cars. Their short flute and overall lengths permit use in cramped quarters.

Size	Approx. Point Size	No. of Flutes	Flute Length	Overall Length	Morse Taper No.	Price Each	
						Spiral List No. 535	Straight List No. 534
5/16	11/64	4	2-3/4	5-11/16	1	52.60	52.60
3/8	15/64	4	2-3/4	5-11/16	1	54.50	—
11/32	15/64	4	2-3/4	5-11/16	1	66.00	—
7/16	1/4	5	3-1/2	6-15/16	2	63.85	63.85
15/32	9/32	5	3-1/2	7-1/16	2	69.50	—
1/2	19/64	5	4	7-9/16	2	65.75	—
9/16	9/32	5	4	7-9/16	2	70.00	70.00
5/8	5/16	5	4-1/2	8-1/16	2	75.00	—
11/16	3/8	5	4-1/2	8-13/16	3	85.37	85.37
3/4	13/32	5	5	9-1/2	3	92.95	100.99
13/16	15/32	5	5	9-1/2	3	99.90	102.95
15/16	19/32	5	5	9-1/2	3	111.00	112.00
1	27/32	5	5	9-1/2	3	125.00	—

● LIST NO. 535 — TYPE "D" SPIRAL FLUTE



● LIST NO. 534 — TYPE "C" STRAIGHT FLUTE





ALIGNING REAMERS

STRAIGHT SHANK WITH 3-EQUAL-FLATS TO FIT 1/2" CHUCKS

Used to align existing holes prior to rivet or bolt installation. The point is tapered to allow entry into overlapping holes. They are also useful in portable reaming.

Size	Flute Length	Overall Length	Shank Size	Price Each
1/4	2-1/2	4-3/8	1/4*	42.46
5/16	2-3/4	4-5/8	5/16	42.46
3/8	2-3/4	4-5/8	3/8	42.46
7/16	3-1/2	5-3/8	7/16	44.00
1/2	4	5-7/8	1/2	44.00
9/16	4	5-7/8	1/2	49.00
39/64	4-1/2	6-3/8	1/2	55.00
5/8	4-1/2	6-3/8	1/2	51.00
11/16	4-1/2	6-3/8	1/2	56.75
3/4	5	6-7/8	1/2	67.95
13/16	5	6-7/8	1/2	68.50
7/8	5	6-7/8	1/2	73.50
15/16	5	6-7/8	1/2	76.90
1	5	6-7/8	1/2	89.90
1-1/16	5	6-7/8	1/2	105.00

* No flats on shank.

■ LIST NO. 535R — SPIRAL FLUTE



STRAIGHT SHANK ALIGNING REAMERS

SET NO. 535RS

4 Piece Set
Contains 1 piece of each:
1/2, 9/16, 5/8, 3/4
Supplied in Wood Block.
SET PRICE — \$199.00

ALIGNING REAMERS- HEX SHANK STYLE

For portable pneumatic tools – short lengths permits use in limited access areas. The shank diameter for each reamer matches socket size for the bolt which will be driven through the newly reamed hole.

Size	Flute Length	Overall Length	Hex Shank Size	Price Each
11/16	4-1/2	6-1/2	1-1/16	71.00
13/16	5	7	1-1/4	86.50
15/16	5	7	1-7/16	96.00
1-1/16	5	7	1-5/8	129.00

■ LIST NO. 535H

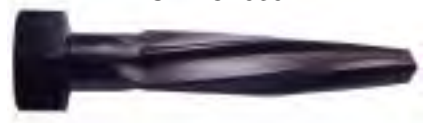

Federal Tool Premium Import

MORSE TAPER FINISHING REAMERS

STRAIGHT FLUTE

This tool is used for accurate reaming of Morse Taper holes in sockets, sleeves and spindles.

▶ LIST NO. 568 — STRAIGHT SHANK
▶ LIST NO. 569 — TAPER SHANK

Size	Diameter		Flute Length	Straight Shank Size	Price Each	
	Small End	Large End			List No. 568	List No. 569
0	.2503	.3674	2-1/4	5/16	59.00	93.00
1	.3674	.5170	3	7/16	79.00	99.00
2	.5696	.7444	3-1/2	5/8	95.00	123.50
3	.7748	.9881	4-1/4	7/8	138.50	172.00
4	1.0167	1.2893	5-1/4	1-1/4	205.00	269.00
5	1.4717	1.8005	6-1/4	1-1/2	390.00	532.75
6	2.1120	2.5550	8-1/2	2	830.00	850.00



SET NO. 568S

5 Piece Set
Contains 1 Piece Each
No. 1-5, Straight Shank
Taper Hand Reamers
Supplied in Wood Block.
SET PRICE — \$895.00

REPAIRMAN'S TAPER REAMER

● LIST NO. 538

- Removes burrs from small holes.
- Enlarges and countersinks holes in soft material.

Size	Range	Price Each
1	1/8 to 1/2	19.00
2	1/8 to 5/8	22.50





HIGH SPEED STEEL

HAND TAPS

STANDARD

PLUG

3-5 THREAD CHAMFER

Most versatile choice for through or blindholes.

TAPER

7-10 THREAD CHAMFER

Have longest standard chamfer for easier starts and less torque.

BOTTOMING

1-2 THREAD CHAMFER

Designed for threading near the bottom of blindholes.

Please specify plug, bottoming or taper chamfer when ordering.

- ▶ LIST NO. 770 — HIGH SPEED STEEL, GROUND THREAD
- ▶ LIST NO. 770 SET — 3 PIECE SET, PLUG, BOTTOMING AND TAPER CHAMFER



Hand taps are the most commonly used general purpose tap. They are recommended for tapping free machining steels, stainless steels, aluminum, zinc and ductile material. Hand taps are utilized in either through or blind hole tapping.

FRACTIONAL SIZES

Size	Threads Per Inch	Thread Limits	No. of Flutes	Price Each	
				List No. 770	3Pc. Set List No. 770 Set
1/4	20	H3	4	6.79	20.37
1/4	28	H3	4	6.79	20.37
5/16	18	H3	4	8.92	26.76
5/16	24	H3	4	8.92	26.76
3/8	16	H3	4	10.12	30.36
3/8	24	H3	4	10.12	30.36
7/16	14	H3	4	17.30	51.90
7/16	20	H3	4	17.30	51.90
1/2	13	H3	4	18.10	54.30
1/2	20	H3	4	20.50	61.50
9/16	12	H3	4	30.37	91.11
9/16	18	H3	4	30.37	91.11
5/8	11	H3	4	36.47	109.41
5/8	18	H3	4	36.47	109.41
11/16	11	H3	4	45.25	135.75
11/16	16	H3	4	45.25	135.75

Size	Threads Per Inch	Thread Limits	No. of Flutes	Price Each	
				List No. 770	3Pc. Set List No. 770 Set
3/4	10	H3	4	51.00	153.00
3/4	16	H3	4	51.00	153.00
7/8	9	H4	4	71.20	213.60
7/8	14	H4	4	71.20	213.60
1	8	H4	4	94.60	283.80
1	12	H4	4	97.67	293.01
1	14	H4	4	97.67	293.01
1-1/8	7	H4	4	153.30	459.90
1-1/8	12	H4	4	162.30	486.90
1-1/4	7	H4	4	201.44	604.32
1-1/4	12	H4	6	204.70	614.10
1-3/8	6	H4	4	253.45	760.35
1-3/8	12	H4	6	255.20	765.60
1-1/2	6	H4	4	283.40	850.20
1-1/2	12	H4	6	288.25	864.75
2	4 -1/2	H4	6	435.55	1306.65

MACHINE SCREW SIZES

Size	Threads Per Inch	Thread Limits	No. of Flutes	Price Each	
				List No. 770	3Pc. Set List No. 770 Set
0	80	H1	2	16.40	49.20
1	64	H1	2	15.35	46.05
1	72	H2	2	15.35	46.05
2	56	H2	3	13.15	39.45
2	64	H2	3	14.25	42.75
3	48	H2	3	10.12	30.36
3	56	H2	3	11.28	33.84
4	36	H2	3	8.95	26.85
4	40	H2	3	8.30	24.90
4	48	H2	3	8.92	26.76

Size	Threads Per Inch	Thread Limits	No. of Flutes	Price Each	
				List No. 770	3Pc. Set List No. 770 Set
5	40	H2	3	8.30	24.90
5	44	H2	3	8.92	26.76
6	32	H3	3	6.40	19.20
6	40	H2	3	6.75	20.25
8	32	H3	4	6.60	19.80
8	36	H2	4	6.75	20.25
10	24	H3	4	6.75	20.25
10	32	H3	4	6.75	20.25
12	24	H3	4	7.09	21.27
12	28	H3	4	7.80	23.40

HIGH SPEED STEEL

STANDARD TAP AND DRILL SETS

◆ SET NO. 770R

Supplied in handy pouch.
Features larger drill diameters which minimize tap breakage by reducing percentage of thread.

SET PRICE — \$49.95

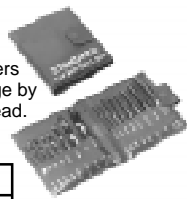

8 Taps	8 Drills
Plug Chamfer	Tap Drill Size
6-32	7/64
8-32	#29
10-24	#23
10-32	#20
1/4-20	13/64
5/16-18	17/64
3/8-16	"P"
1/2-13	7/16

◆ SET NO. 770X

HAND TAPS

Supplied in metal index.
Features smaller drill diameters to create more percentage of thread.

SET PRICE — \$72.50

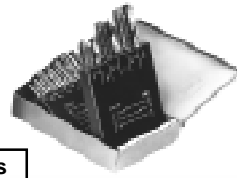

9 Taps	9 Drills
Plug Chamfer	Tap Drill Size
6-32	#36
8-32	#29
10-24	#25
10-32	#21
1/4-20	#7
5/16-18	"F"
3/8-16	5/16
7/16-14	"U"
1/2-13	27/64

HAND TAP SET

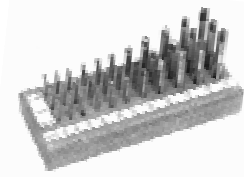

◆ SET NO. 770S

33 Piece Set
Contains 1 piece each of:
1/4-20, 5/16-18, 3/8-16, 7/16-14, 1/2-13, 4-40, 5-40, 6-32, 8-32, 10-24 and 10-32.
All sizes in plug, bottoming and taper chamfer. Supplied in wood stand.

SET PRICE — \$149.95

◆ SET NO. 780X

SPIRAL POINT

Supplied in metal index.
Features smaller drill diameters to create more percentage of thread.

SET PRICE — \$79.50

HAND TAPS

OPTIONAL THREAD LIMITS

● LIST NO. 770H - GROUND THREAD

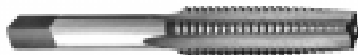

Please specify plug, bottoming or taper chamfer when ordering.

Size	Threads Per Inch	Thread Limits	No. of Flutes	Chamfer Available	Price Each
0	80	H2	2	P,T,B	16.40
2	56	H1	3	P,T	14.20
2	64	H1	3	P,T,B	14.20
3	48	H1	3	P,T,B	11.20
3	56	H1	3	P,T,B	11.20
4	40	H1	3	P,T,B	8.90
4	40	H4	3	P,T	8.90
4	48	H1	3	P,T	8.90
5	40	H1	3	P,T,B	8.90
5	44	H1	3	P,T,B	8.90
6	32	H1	3	P,T	7.80
6	32	H2	3	P,T,B	7.80
8	32	H1	4	P,T,B	7.80
8	36	H1	4	P,T	8.90
10	24	H1	4	P,T,B	6.90
10	24	H2	4	P,T,B	7.80
10	32	H1	4	P,T,B	7.80
10	32	H2	4	P,T,B	6.95
10	32	H6	4	P,T,B	8.97
12	24	H2	4	P,T,B	7.10
12	28	H2	4	P,T,B	7.80
1/4	20	H1	4	P,T,B	9.00
1/4	20	H2	4	P,T,B	9.00
1/4	20	H5	4	P,T,B	8.60
1/4	28	H1	4	P,T,B	8.65
1/4	28	H2	4	P,T,B	9.00
5/16	18	H2	4	T	10.15
5/16	18	H4	4	P,T,B	10.00
5/16	18	H5	4	P,T,B	10.00
5/16	18	H7	4	P,T,B	10.00
5/16	24	H1	4	P,T,B	10.00
5/16	24	H2	4	P,T,B	10.00
5/16	24	H4	4	P,T,B	10.00
3/8	16	H1	4	P,T,B	13.00
3/8	16	H2	4	P,T,B	11.35
3/8	16	H5	4	P,T,B	11.35
3/8	24	H1	4	P,T	13.00
3/8	24	H2	4	P,T,B	11.90
3/8	24	H4	4	P,T,B	11.35
3/8	24	H5	4	P,T	11.35
7/16	14	H1	4	P,T,B	18.90
7/16	14	H2	4	P,T	18.90
7/16	14	H5	4	P,T,B	18.90

P=Plug, T=Taper, B=Bottoming

Size	Threads Per Inch	Thread Limits	No. of Flutes	Chamfer Available	Price Each
7/16	20	H1	4	P,T	18.90
7/16	20	H2	4	P,T,B	18.90
7/16	20	H5	4	P,T,B	18.90
7/16	20	H6	4	P,T,B	18.90
7/16	20	H10	4	P,T	18.90
1/2	13	H1	4	P,T	22.20
1/2	13	H2	4	P,T	22.20
1/2	13	H5	4	P,T,B	22.20
1/2	13	H8	4	P,T	22.20
1/2	13	H10	4	P,T,B	22.20
1/2	20	H1	4	P,T	22.20
1/2	20	H2	4	P,T	22.20
1/2	20	H5	4	P,T,B	22.20
9/16	12	H5	4	P,T	33.00
9/16	18	H1	4	P,T	33.00
9/16	18	H2	4	P,T,B	33.00
9/16	18	H5	4	P,T,B	33.00
5/8	11	H5	4	P,T,B	41.90
5/8	18	H1	4	P,T	41.90
5/8	18	H2	4	P,T,B	41.90
5/8	18	H4	4	P,T,B	41.90
5/8	18	H5	4	P,T	41.90
3/4	10	H1	4	P,T,B	55.00
3/4	10	H2	4	P,T,B	55.00
3/4	10	H5	4	P,T,B	55.00
7/8	9	H3	4	P,T	74.75
7/8	9	H5	4	P,T	74.75
7/8	9	H6	4	P,T,B	74.75
7/8	14	H2	4	T	74.75
7/8	14	H3	4	P,T,B	74.75
7/8	14	H10	4	P,T	74.75
1	8	H1	4	P,T,B	97.50
1	8	H2	4	P,T	97.50
1	12	H2	4	P,T,B	97.50
1	14	H1	4	P,T,B	97.50
1	14	H2	4	P,T,B	97.50
1	14	H3	4	P,T	97.50
1-1/8	7	H8	4	P,T,B	155.00
1-1/8	12	H1	4	P,T,B	166.00
1-1/8	12	H3	4	P,T,B	165.00
1-1/8	12	H5	4	P,T	165.00
1-1/2	12	H8	4	P,T,B	309.00

Partial listing, inquire for additional sizes.

OPTIONAL FLUTES



● LIST NO. 770F — GROUND THREAD

Size	Threads Per Inch	Thread Limits	No. of Flutes	Chamfer Available	Price Each
2	56	H2	2	P,B,T	14.20
4	40	H2	2	P,B,T	8.90
6	32	H3	2	P,T	7.10
8	32	H3	2	P,B,T	6.70
8	32	H3	3	P,T	6.70
10	24	H3	2	P,T	6.90
10	24	H3	3	P,T	6.90
10	32	H3	2	P,B,T	6.90
12	28	H3	2	P,T	7.80
1/4	20	H3	3	P,B,T	8.90
1/4	28	H3	2	P,B,T	9.00
1/4	28	H3	3	P,B,T	9.00
5/16	18	H3	2	P,T	11.30
5/16	18	H3	3	P,B,T	10.00
3/8	16	H3	3	P,B,T	11.30
3/8	24	H3	3	P,B,T	13.00
7/16	14	H3	3	P,B,T	18.90
7/16	20	H3	3	P,T	18.90
1/2	13	H3	3	P,B,T	22.50
1/2	20	H3	3	P,B,T	22.50

P=Plug, T=Taper, B=Bottoming

COMBINED OPTIONAL THREAD LIMITS AND OPTIONAL FLUTES



● LIST NO. 770HF — GROUND THREAD

Size	Threads Per Inch	Thread Limits	No. of Flutes	Chamfer Available	Price Each
6	40	H1	2	P,T	7.80
8	32	H1	2	P,T	7.80
8	32	H2	2	P,B,T	7.80
10	24	H1	2	P,T	6.95
10	24	H2	3	P,T	7.80
1/4	20	H1	3	P,T	8.90
1/4	20	H3	2	P,T	8.90
1/4	20	H5	3	P,T	8.90
1/4	28	H1	3	P,T	8.90
5/16	18	H1	3	P,B,T	10.00
5/16	18	H5	2	P,B,T	11.40
5/16	18	H5	3	P,B,T	10.00
5/16	24	H2	3	P,B,T	10.00
5/16	24	H4	3	P,T	10.00
3/8	16	H1	3	P,B,T	13.00
3/8	16	H5	3	P,B,T	13.00
3/8	16	H8	3	P,T	13.00
3/8	24	H2	3	P,B,T	13.00
3/8	24	H4	3	P,B,T	13.00
7/16	14	H5	3	P,B,T	18.90
1/2	13	H5	3	P,B,T	22.50
1/2	20	H1	3	P,B,T	22.50
1/2	20	H5	3	P,T	22.50

Partial listing, inquire for additional sizes.

HIGH SPEED STEEL

SPIRAL POINTED TAPS

STANDARD

▶ LIST NO. 780 — GROUND THREAD

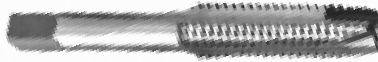

Spiral Pointed Taps are used to solve the problem of tap breakage in through hole tapping in a wide variety of materials. They are very effective, because they shoot the chips ahead of the tap thereby reducing loading and clogging in the flutes.

FRACTIONAL SIZES

PLUG CHAMFER

MACHINE SCREW SIZES

Size	Threads Per Inch	Thread Limits	No. of Flutes	Price Each
1/4	20	H3	2	7.95
1/4	28	H3	2	7.95
5/16	18	H3	2	9.00
5/16	24	H3	2	9.00
3/8	16	H3	3	10.70
3/8	24	H3	3	11.65
7/16	14	H3	3	18.27
7/16	20	H3	3	18.27
1/2	13	H3	3	18.63
1/2	20	H3	3	19.80
9/16	12	H3	3	38.60
9/16	18	H3	3	38.60
5/8	11	H3	3	41.65
5/8	18	H3	3	41.65
3/4	10	H3	3	58.78
3/4	16	H3	3	58.78
7/8	9	H4	3	80.65
7/8	14	H4	3	80.65
1	8	H4	3	111.90
1	12	H4	3	111.90
1	14	H4	3	111.90

Size	Threads Per Inch	Thread Limits	No. of Flutes	Price Each
0	80	H1	2	20.20
1	64	H1	2	18.20
1	72	H2	2	18.20
2	56	H2	2	15.60
2	64	H2	2	17.65
3	48	H2	2	12.45
3	56	H2	2	13.50
4	36	H2	2	11.65
4	40	H2	2	10.05
4	48	H2	2	11.62
5	40	H2	2	9.95
5	44	H2	2	11.65
6	32	H3	2	8.35
6	40	H2	2	9.50
8	32	H3	2	8.35
8	36	H2	2	9.50
10	24	H3	2	8.35
10	32	H3	2	8.35
12	24	H3	2	9.50
12	28	H3	2	9.50
14	20	H3	2	12.50

HIGH SPEED STEEL

OPTIONAL THREAD LIMITS

● LIST NO. 780H — GROUND THREAD



FRACTIONAL SIZES

PLUG CHAMFER

MACHINE SCREW SIZES

Size	Threads Per Inch	Thread Limits	No. of Flutes	Price Each
1/4	28	H4	2	9.50
5/16	18	H1	2	11.90
5/16	24	H1	2	11.90
5/16	24	H2	2	11.90
5/16	24	H4	2	11.90
5/16	24	H5	2	11.95
3/8	16	H1	3	13.60
3/8	16	H5	3	13.60
3/8	24	H1	2	13.60
3/8	24	H2	3	13.60
7/16	14	H2	3	20.12
1/2	13	H1	3	24.30
1/2	20	H5	3	24.30
9/16	12	H1	3	38.60
5/8	11	H5	3	41.60
7/8	9	H5	3	80.65
1	8	H6	3	111.90

Size	Threads Per Inch	Thread Limits	No. of Flutes	Price Each
0	80	H2	2	20.30
1	64	H2	2	18.30
2	56	H3	2	19.10
2	64	H1	2	17.65
3	48	H1	3	15.20
3	56	H1	2	13.90
4	40	H1	2	11.60
4	48	H1	2	11.62
5	40	H1	3	11.62
5	44	H1	3	11.65
6	32	H1	2	9.50
6	32	H4	2	9.50
8	36	H3	2	9.50
10	24	H1	2	10.40
10	24	H2	2	9.50
10	24	H5	2	9.50
10	32	H1	2	9.50
10	32	H4	2	9.50
10	32	H5	2	9.50
12	24	H2	2	10.50

Partial listing, please inquire for additional sizes.

SPIRAL POINTED BOTTOMING TAPS

● LIST NO. 780B — GROUND THREAD



Size	Threads Per Inch	Thread Limits	No. of Flutes	Price Each
5	40	H2	2	13.15
6	32	H3	2	10.50
8	32	H3	2	10.50
10	24	H3	2	10.20

Size	Threads Per Inch	Thread Limits	No. of Flutes	Price Each
10	32	H3	2	10.20
12	24	H3	2	12.00
1/4	20	H3	2	10.50
5/16	18	H3	2	12.70

COATED HAND TAPS

GROUND THREAD



Surface Treated: *Steam Oxide Coating* produces a thin iron oxide surface which reduces friction between the tool and the chips, acting as a lubrication media.

TiN Coating: *Titanium Nitride Coating* is the ideal coating for a wide range of applications, materials and cutting conditions where tool life and elevated feeds and speeds are the operating objectives. The high lubricity of TiN Coating facilitates chip flow, prevents build up, reduces cutting forces and regulates temperature. TiN Coating reduces wear and improves chip formation to extend tool life. In addition, the high hardness and low coefficient of friction of TiN reduce erosion, abrasion, metal on metal wear and corrosion.

TiAlN Coating: *Titanium Aluminum Nitride Coating* is ideal for high temperature cutting operations in many materials. When TiAlN is exposed to high cutting temperature it forms a hard aluminum oxide layer with low thermal conductivity and high chemical stability. As cutting temperatures increase, TiAlN insulates the tool and ejects heat into the chips. As a result, production levels increase with higher speeds, reduced down time and longer tool life.



FRACTIONAL SIZES

Size	Threads Per Inch	Thread Limits	No. of Flutes	Price Each		
				List No. 770ST	List No. 770T	List No. 770TA
1/4	20	H3	4	6.55	12.77	19.92
1/4	28	H3	4	6.55	12.77	19.92
5/16	18	H3	4	8.10	16.52	25.77
5/16	24	H3	4	8.10	16.52	25.77
3/8	16	H3	4	9.15	17.48	27.27
3/8	24	H3	4	9.15	17.48	27.27
7/16	14	H3	4	15.60	23.24	36.25
7/16	20	H3	4	15.60	23.24	36.25
1/2	13	H3	4	16.65	24.14	37.66
1/2	20	H3	4	18.60	26.04	40.62
9/16	12	H3	4	27.75	42.18	65.80
9/16	18	H3	4	27.75	42.18	65.80
5/8	11	H3	4	33.15	47.40	73.94
5/8	18	H3	4	33.15	47.40	73.94
11/16	11	H3	4	40.00	55.20	86.11
11/16	16	H3	4	40.00	55.20	86.11
3/4	10	H3	4	46.20	60.98	95.13
3/4	16	H3	4	46.20	60.98	95.13
7/8	9	H4	4	64.75	80.29	125.25
7/8	14	H4	4	64.75	80.29	125.25
1	8	H4	4	85.00	110.50	172.38
1	12	H4	4	89.00	114.81	179.10
1	14	H4	4	86.00	110.08	171.72
1-1/8	7	H4	4	139.00	152.90	238.52
1-1/8	12	H4	4	148.00	168.72	263.20
1-1/4	7	H4	4	182.00	231.14	360.58
1-1/4	12	H4	6	186.00	234.36	365.60
1-3/8	6	H4	4	230.00	358.80	559.73
1-3/8	12	H4	6	232.00	361.92	564.60
1-1/2	6	H4	4	265.00	389.55	607.70
1-1/2	12	H4	6	270.00	396.90	619.16

- LIST NO. 770ST --- SURFACE TREATED HAND TAPS
- LIST NO. 770T --- TiN COATED HAND TAPS
- LIST NO. 770TA --- TiAlN COATED HAND TAPS

Please specify plug, bottoming, or taper chamfer when ordering.

MACHINE SCREW SIZES

Size	Threads Per Inch	Thread Limits	No. of Flutes	Price Each		
				List No. 770ST	List No. 770T	List No. 770TA
0	80	H1	2	15.00	16.80	26.21
1	64	H1	2	13.90	15.57	24.29
1	72	H2	2	13.90	15.57	24.29
2	56	H2	3	11.80	13.90	21.68
2	64	H2	3	12.25	15.54	24.24
3	48	H2	3	9.20	11.50	17.94
3	56	H2	3	10.30	12.26	19.13
4	36	H2	3	8.10	10.45	16.30
4	40	H2	3	7.50	9.90	15.44
4	48	H2	3	8.10	10.45	16.30
5	40	H2	3	7.50	9.90	15.44
5	44	H2	3	8.10	10.37	16.18
6	32	H3	3	5.70	8.55	13.34
6	40	H2	3	6.40	8.66	13.51
8	32	H3	4	5.95	11.48	17.91
8	36	H2	4	6.10	11.77	18.36
10	24	H3	4	6.10	11.77	18.36
10	32	H3	4	6.10	11.77	18.36
12	24	H3	4	6.40	11.71	18.27
12	28	H3	4	7.10	13.28	20.72

COATED SPIRAL POINTED TAPS

- LIST NO. 780ST --- SURFACE TREATED SPIRAL POINTED TAPS
- LIST NO. 780T --- TiN COATED SPIRAL POINTED TAPS
- LIST NO. 780TA --- TiAlN COATED SPIRAL POINTED TAPS



FRACTIONAL SIZES

Size	Threads Per Inch	Thread Limits	No. of Flutes	Price Each		
				List No. 780ST	List No. 780T	List No. 780TA
1/4	20	H3	2	7.50	12.20	19.03
1/4	28	H3	2	7.50	12.20	19.03
5/16	18	H3	2	8.20	11.50	17.94
5/16	24	H3	2	8.20	11.50	17.94
3/8	16	H3	3	9.80	14.70	22.90
3/8	24	H3	3	10.50	14.70	22.90
7/16	14	H3	3	16.70	23.50	36.60
7/16	20	H3	3	16.70	23.50	36.60
1/2	13	H3	3	17.00	27.80	43.30
1/2	20	H3	3	19.80	27.80	43.30
9/16	12	H3	3	27.80	35.24	43.30
9/16	18	H3	3	27.80	35.24	43.30
5/8	11	H3	3	37.90	53.00	82.60
5/8	18	H3	3	37.90	53.00	82.60
3/4	10	H3	3	53.65	75.00	117.00
3/4	16	H3	3	55.39	75.00	117.00
7/8	9	H4	3	71.60	98.00	153.00
7/8	14	H4	3	71.60	98.00	153.00
1	8	H4	3	99.35	137.00	214.00
1	12	H4	3	99.35	137.00	214.00
1	14	H4	3	99.35	137.00	214.00

MACHINE SCREW SIZES

Size	Threads Per Inch	Thread Limits	No. of Flutes	Price Each		
				List No. 780ST	List No. 780T	List No. 780TA
0	80	H1	2	18.39	25.75	40.17
1	64	H1	2	16.70	25.75	40.17
1	72	H2	2	16.70	25.75	40.17
2	56	H2	2	14.00	19.69	30.72
2	64	H2	2	16.00	19.69	30.72
3	48	H2	2	11.25	15.90	24.80
3	56	H2	2	12.10	15.90	24.80
4	36	H2	2	10.50	12.70	19.81
4	40	H2	2	9.00	12.70	19.81
4	48	H2	2	10.50	12.70	19.81
5	40	H2	2	9.00	12.70	19.81
5	44	H2	2	10.50	12.70	19.81
6	32	H3	2	7.50	10.70	16.69
6	40	H2	2	8.70	10.70	16.69
8	32	H3	2	7.50	10.70	16.69
8	36	H2	2	8.70	10.70	16.69
10	24	H3	2	7.50	10.70	16.69
10	32	H3	2	7.50	10.70	16.69
12	24	H3	2	8.70	12.20	19.03
12	28	H3	2	8.70	12.20	19.03
14	20	H3	2	9.75	12.20	19.03

MAINTENANCE TAPS

HAND TAPS

PLUG

3-5 THREAD CHAMFER

Most versatile choice for through or blind holes.

TAPER

7-10 THREAD CHAMFER

Have longest standard chamfer for easier starts and less torque.

BOTTOMING

1-2 THREAD CHAMFER

Designed for threading near the bottom of blind holes.

Please specify plug, bottoming or taper chamfer when ordering.

- ▶ LIST NO. 772 — HAND TAPS
- ▶ LIST NO. 772 SET — 3 PIECE SET

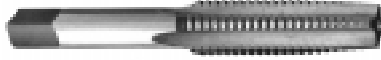

These taps are made from quality high speed steel. Though intended for general maintenance applications, they perform well in light production runs.

FRACTIONAL SIZES

Size	Threads Per Inch	Price Each	
		List No. 772	3 Pc. Set List No. 772 Set
1/4	20	4.90	14.70
1/4	28	4.90	14.70
5/16	18	5.70	17.10
5/16	24	5.70	17.10
3/8	16	6.70	20.10
3/8	24	6.70	20.10
7/16	14	10.20	30.60
7/16	20	10.20	30.60
1/2	13	12.20	36.60
1/2	20	12.20	36.60
9/16	12	18.40	55.20

Size	Threads Per Inch	Price Each	
		List No. 772	3 Pc. Set List No. 772 Set
9/16	18	18.40	55.20
5/8	11	22.50	67.50
5/8	18	22.50	67.50
11/16	11	22.50	67.50
11/16	16	27.80	83.40
3/4	10	31.20	93.60
3/4	16	31.20	93.60
7/8	9	43.00	93.60
7/8	14	43.00	93.60
1	8	57.60	172.80

Size	Threads Per Inch	Price Each	
		List No. 772	3 Pc. Set List No. 772 Set
1	12	57.60	172.80
1	14	57.60	172.80
1-1/8	7	91.70	275.10
1-1/8	12	91.70	275.10
1-1/4	7	115.29	345.87
1-1/4	12	115.29	345.87
1-3/8	6	145.10	435.30
1-3/8	12	145.10	435.30
1-1/2	6	168.50	401.76
1-1/2	12	168.50	401.76

MACHINE SCREW SIZES

Size	Threads Per Inch	Price Each	
		List No. 772	3 Pc. Set List No. 772 Set
0	80	10.80	32.40
1	64	9.94	29.82
1	72	9.94	29.82
2	56	9.19	27.57
2	64	9.19	27.57
3	48	7.20	21.60
3	56	7.20	21.60

Size	Threads Per Inch	Price Each	
		List No. 772	3 Pc. Set List No. 772 Set
4	40	5.70	17.10
4	48	5.70	17.10
5	40	5.70	17.10
5	44	5.70	17.10
6	32	4.40	13.20
6	40	4.40	13.20

Size	Threads Per Inch	Price Each	
		List No. 772	3 Pc. Set List No. 772 Set
8	32	4.40	13.20
8	36	4.40	13.20
10	24	4.60	13.80
10	32	4.60	13.80
12	24	5.00	15.00
12	28	5.00	15.00
12	32	5.70	17.10

SPIRAL POINTED TAPS

PLUG CHAMFER

- ▶ LIST NO. 782



FRACTIONAL SIZES

Size	Threads Per Inch	Price Each
1/4	20	5.70
1/4	28	5.70
5/16	18	6.10
5/16	24	6.10
3/8	16	7.50
3/8	24	7.50
7/16	14	12.50

Size	Threads Per Inch	Price Each
7/16	20	12.50
1/2	13	12.50
1/2	20	14.89
9/16	12	22.89
9/16	18	22.89
5/8	11	28.18
5/8	18	28.18

Size	Threads Per Inch	Price Each
3/4	10	40.00
3/4	16	40.00
7/8	9	55.09
7/8	14	55.09
1	8	73.77
1	12	73.77
1	14	73.77

MACHINE SCREW SIZES

Size	Threads Per Inch	Price Each
0	80	15.30
1	64	14.18
1	72	14.18
2	56	11.90
2	64	13.60
3	48	9.61
3	56	10.61

Size	Threads Per Inch	Price Each
4	40	7.80
4	48	7.80
5	40	7.80
5	44	7.80
6	32	6.49
6	40	6.49

Size	Threads Per Inch	Price Each
8	32	5.65
8	36	6.49
10	24	5.70
10	32	5.70
12	24	6.49
12	28	6.49

CARBON STEEL MAINTENANCE TAPS

HAND TAPS

**PLUG
3-5 THREAD CHAMFER**
Most versatile choice for through or blind holes.

**TAPER
7-10 THREAD CHAMFER**
Have longest standard chamfer for easier starts and less torque.

**BOTTOMING
1-2 THREAD CHAMFER**
Designed for threading near the bottom of blind holes.

Please specify plug, bottoming or taper chamfer when ordering.

- LIST NO. 772CB — HAND TAPS
- LIST NO. 772CB SET — 3 PIECE SET

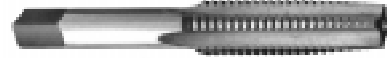

FRACTIONAL SIZES

Size	Threads Per Inch	Price Each	
		List No. 772CB	3 Pc. Set List No. 772CB Set
1/8	40	1.94	5.82
5/32	32	1.94	5.82
5/32	36	1.94	5.82
3/16	24	2.14	6.42
3/16	32	2.14	6.42
1/4	20	2.50	7.50
1/4	28	2.50	7.50
5/16	18	3.06	9.18
5/16	24	3.06	9.18
3/8	16	3.42	10.26
3/8	24	3.42	10.26
7/16	14	4.49	13.47
7/16	20	4.49	13.47

Size	Threads Per Inch	Price Each	
		List No. 772CB	3 Pc. Set List No. 772CB Set
1/2	13	5.15	15.45
1/2	20	5.15	15.45
9/16	12	6.99	20.97
9/16	18	6.99	20.97
5/8	11	7.75	23.25
5/8	18	7.75	23.25
11/16	11	9.90	29.70
3/4	10	11.02	33.06
3/4	16	11.02	33.06
7/8	9	15.45	46.35
7/8	14	15.45	46.35
1	8	19.23	57.69

Size	Threads Per Inch	Price Each	
		List No. 772CB	3 Pc. Set List No. 772CB Set
1	12	19.23	57.69
1	14	19.23	57.69
1-1/8	7	38.35	115.05
1-1/8	12	38.35	115.05
1-1/4	7	44.17	132.51
1-1/4	12	44.17	132.51
1-3/8	6	50.85	152.55
1-3/8	12	50.85	152.55
1-1/2	6	59.93	179.79
1-1/2	12	59.93	179.79
2	4-1/2	65.98	197.94
2-1/4	4-1/2	72.42	217.26

MACHINE SCREW SIZES

Size	Threads Per Inch	Price Each	
		List No. 772CB	3 Pc. Set List No. 772CB Set
0	80	3.72	11.16
1	64	3.47	10.41
1	72	3.47	10.41
2	56	3.32	9.96
2	64	3.32	9.96
3	48	2.40	7.20
3	56	2.40	7.20

Size	Threads Per Inch	Price Each	
		List No. 772CB	3 Pc. Set List No. 772CB Set
4	36	2.40	7.20
4	40	2.40	7.20
4	48	2.40	7.20
5	40	1.99	5.97
5	44	1.99	5.97
6	32	1.99	5.97
6	40	1.99	5.97

Size	Threads Per Inch	Price Each	
		List No. 772CB	3 Pc. Set List No. 772CB Set
8	32	1.99	5.97
8	36	1.99	5.97
10	24	2.14	6.42
10	32	2.19	6.57
12	24	2.49	7.47
12	28	2.49	7.47

SETS

**CARBON TAP SET
SET NO. 772CBC**
4 Piece NC Set
Contains 1 piece of each:
10-24, 1/4-20, 5/16-18, 3/8-16
SET PRICE — \$9.75



**CARBON TAP SET
SET NO. 772CBF**
4 Piece NF Set
Contains 1 piece of each:
10-32, 1/4-28, 5/16-24, 3/8-24
SET PRICE — \$9.75



CARBON STEEL MAINTENANCE METRIC TAPS

PLUG CHAMFER

- LIST NO. 773MCB — HAND TAPS

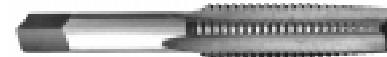

Size mm	Pitch mm	Price Each
3	.50	2.75
3	.60	2.75
4	.70	2.50
4	.75	2.50
5	.80	2.50
5	.90	2.50
6	1.00	2.75
7	1.00	3.25
8	1.00	3.45
8	1.25	3.45

Size mm	Pitch mm	Price Each
9	.75	3.90
9	1.00	3.90
9	1.25	4.65
10	1.00	4.65
10	1.25	4.65
10	1.50	4.65
11	1.50	5.00
12	1.25	5.40
12	1.50	5.40
12	1.75	5.40

Size mm	Pitch mm	Price Each
14	1.25	7.50
14	1.50	7.50
14	2.00	7.50
16	1.50	9.50
16	2.00	9.50
18	1.50	12.75
18	2.50	12.75
20	1.50	15.00
24	3.00	25.00



PRODUCTION MAX™

HIGH PERFORMANCE TAPS

SURFACE TREATED

● LIST NO. 780HSP — SPIRAL POINTED TAPS

For tough jobs in stainless steels and free machining steels. Ideally suited for through hole tapping.



PLUG CHAMFER

Size	Threads per Inch	No. of Flutes	Price Each	Size	Threads per Inch	No. of Flutes	Price Each
6	32	2	13.16	7/16	14	3	23.89
8	32	3	13.16	7/16	20	3	23.89
10	24	3	13.18	1/2	13	3	27.59
10	32	3	13.18	1/2	20	3	27.59
1/4	20	3	14.50	9/16	12	3	42.75
1/4	28	3	14.50	9/16	18	3	42.75
5/16	18	3	16.18	5/8	11	3	50.11
5/16	24	3	16.18	5/8	18	3	50.11
3/8	16	3	18.49	3/4	10	3	78.69
3/8	24	3	18.49				

● LIST NO. 780HSF — SPIRAL FLUTED TAPS

For tough hole tapping in stainless steels and free machining steels. Ideally suited for blind hole tapping.



SEMI BOTTOMING CHAMFER

Size	Threads per Inch	No. of Flutes	Price Each	Size	Threads per Inch	No. of Flutes	Price Each
6	32	3	18.69	7/16	14	3	38.25
8	32	3	18.69	7/16	20	3	38.25
10	24	3	19.15	1/2	13	3	46.61
10	32	3	19.15	1/2	20	3	46.61
1/4	20	3	21.12	9/16	12	3	70.71
1/4	28	3	21.12	9/16	18	3	70.71
5/16	18	3	23.53	5/8	11	4	77.65
5/16	24	3	23.53	5/8	18	4	77.65
3/8	16	3	26.22	3/4	10	4	100.31
3/8	24	3	26.22				

SPIRAL FLUTED TAPS

Please specify plug or bottoming when ordering.



● LIST NO. 776 – FAST SPIRAL – 52° HELIX ANGLE

Size	Threads per Inch/ m m	Thread Limits	No. of Flutes	Price Each	
				List No. 776	List No. 776SL
1/4	20	H3	3	13.95	14.50
1/4	20	H5	3	15.90	—
1/4	28	H3	3	13.95	14.50
5/16	18	H3	3	17.75	18.50
5/16	18	H5	3	19.20	20.45
5/16	24	H3	3	17.75	21.25
3/8	16	H3	3	20.40	23.40
3/8	24	H3	3	20.40	21.51
3/8	24	H5	3	—	32.21
7/16	14	H3	3	30.50	32.21
7/16	20	H3	3	30.50	38.50
1/2	13	H3	3	36.75	38.50
1/2	20	H3	3	36.75	65.24
5/8	11	H3	3	54.70	—
5/8	18	H3	4	54.70	—
3/4	10	H3	4	65.24	—
3/4	16	H3	4	65.24	—

● LIST NO. 776SL – SLOW SPIRAL – 30° HELIX ANGLE

Size	Threads per Inch/ m m	Threads Limits	No. of Flutes	Price Each	
				List No. 776	List No. 776SL
3	40	H2	2	19.60	—
4	40	H2	2	16.20	15.40
5	40	H2	2	16.20	15.40
6	32	H3	2	13.25	11.95
6	40	H2	2	15.66	—
8	32	H3	3	13.25	11.95
8	36	H2	3	15.66	15.66
10	24	H3	3	13.25	11.95
10	32	H3	3	13.25	11.95
12	24	H3	3	14.35	14.32
M5	.8	D4	3	19.90	—
M6	1.0	D5	3	19.90	—
M8	.75	D5	3	19.90	—
M8	1.25	D5	3	19.90	—
M10	1.50	D6	3	26.80	—
M12	1.25	D6	3	37.50	—
M12	1.75	D6	3	37.50	—

+ .005 OVERSIZE TAPS

PLUG CHAMFER

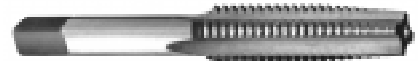

Primarily used where a part will be plated or heat treated after tapping

● LIST NO. 775 +.005 HAND TAPS

Size	Threads per Inch	No. of Flutes	Price Each	Size	Threads per Inch	No. of Flutes	Price Each
2	56	3	9.00	1/2	13	4	19.95
4	40	3	9.00	1/2	20	4	19.95
5	40	3	9.00	9/16	12	4	33.29
6	32	3	8.35	9/16	18	4	33.29
6	40	3	8.35	5/8	11	4	37.79
8	32	4	8.35	5/8	18	4	37.79
10	24	4	8.35	3/4	10	4	49.95
10	32	4	8.35	7/8	14	4	59.95
1/4	20	4	8.19	1	8	4	69.38
1/4	28	4	10.39	1	12	4	69.38
5/16	18	4	10.39	1	14	4	69.38
3/8	16	4	11.89	1-1/8	12	4	74.92
3/8	24	4	11.89	1-1/4	7	4	78.92
7/16	14	4	17.89	1-1/4	12	4	78.92
7/16	20	4	17.89				

● LIST NO. 785 +.005 SPIRAL POINTED TAPS

Size	Threads per Inch	No. of Flutes	Price Each	Size	Threads per Inch	No. of Flutes	Price Each
5	40	2	11.29	7/16	14	3	19.98
6	32	2	10.99	1/2	13	3	22.19
6	40	2	10.99	1/2	20	3	22.19
8	32	2	10.99	9/16	12	3	34.38
10	24	2	10.99	9/16	18	3	34.38
10	32	2	10.99	5/8	11	3	37.89
12	24	2	10.05	3/4	10	3	49.95
1/4	20	2	9.48	7/8	9	3	62.48
5/16	18	2	10.89	7/8	14	3	62.48
5/16	24	2	10.89	1	8	3	69.99
3/8	16	3	12.38	1	12	3	69.99
3/8	24	3	12.38				

SET NO. 775S
8 PIECE SET
 Contains 1 Piece of Each:
 NC 6-32 thru 1/2-13 and 10-32
 Excludes 7/16
 Supplied in Wood Block
SET PRICE - \$83.00

SET NO. 785S
8 PIECE SET
 Contains 1 Piece of Each:
 NC 6-32 thru 1/2-13 and 10-32
 Excludes 7/16
 Supplied in Wood Block
SET PRICE - \$98.00

SET NO. 785A
16 PIECE SET
 Contains 1 Piece of Each:
 Combination of Set 775S & 785S
 Supplied in Wood Block
SET PRICE - \$182.00

HIGH SPEED STEEL

METRIC TAPS

GROUND THREAD

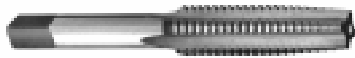

- LIST NO. 773M — HAND TAPS*
- LIST NO. 773M SET — 3 PIECE SETS, PLUG, BOTTOMING AND TAPER CHAMFER
- LIST NO. 774M — SPIRAL POINTED TAPS (Plug Chamfer Only)

*Please specify plug, bottoming or taper chamfer when ordering.

Size mm	Pitch mm	No. of Flutes	Hand Taps		No. of Flutes	Spiral Pointed
			Price Each			Price Each
			List No. 773M	List No. 773M Set		List No. 774M
1.6	.35	2	19.20	57.60	2	21.49
1.8	.35	2	19.20	57.60	2	21.49
2	.40	3	19.20	57.60	2	19.80
2.2	.45	3	11.80	35.40	2	14.28
2.3	.40	3	11.80	35.40	2	14.28
2.5	.45	3	11.80	35.40	2	14.28
2.6	.45	3	11.80	35.40	2	14.28
2.8	.45	3	11.80	35.40	2	14.28
3	.50	3	9.80	29.40	2	11.37
3	.60	3	8.10	24.30	—	—
3.5	.60	3	8.10	24.30	—	9.79
4	.50	4	8.40	25.20	2	9.79
4	.70	4	8.10	24.30	2	9.79
4	.75	4	8.40	25.20	—	—
4.5	.75	4	8.10	24.30	2	9.79
5	.50	4	8.40	25.20	2	9.79
5	.80	4	8.10	24.30	2	9.79
5	.90	4	8.40	25.20	—	—
6	.50	4	8.60	25.80	—	—
6	.75	4	8.60	25.80	2	9.79
6	.80	—	—	—	2	9.79
6	1.00	4	8.60	25.80	2	9.79
6.3	1.00	4	9.30	27.90	2	9.79
7	.50	4	9.30	27.90	2	11.37
7	1.00	4	9.30	27.90	2	11.37
8	.75	4	9.20	27.60	2	11.37
8	1.00	4	9.20	27.60	2	11.37
8	1.25	4	9.20	27.60	2	11.37
8	1.50	4	9.27	27.81	2	11.37
9	.50	4	12.09	36.27	2	11.37
9	1.00	4	12.09	36.27	2	11.37
9	1.25	4	12.09	36.27	2	11.37
10	.75	4	13.10	39.30	—	—
10	1.00	4	13.10	39.30	3	18.78
10	1.25	4	13.10	39.30	3	18.78
10	1.50	4	13.80	41.40	3	18.78
11	.75	4	17.59	52.77	3	18.78
11	1.25	4	17.59	52.77	—	—
11	1.50	4	17.59	52.77	3	18.78
12	.80	4	—	—	3	23.00
12	1.00	4	21.00	63.00	—	—
12	1.25	4	21.00	63.00	3	23.00
12	1.50	4	21.00	63.00	3	23.00
12	1.75	4	20.79	62.37	3	23.00
13	1.25	4	31.20	93.60	—	—
14	1.00	4	31.20	93.60	—	—
14	1.25	4	31.20	93.60	3	34.85
14	1.50	4	31.20	93.60	3	34.85
14	2.00	4	31.20	93.60	3	34.85
15	1.00	4	38.27	114.81	—	—
15	1.50	4	38.27	114.81	—	—
15	2.00	4	38.27	114.81	—	—
16	1.00	4	38.27	114.81	3	40.63
16	1.50	4	38.27	114.81	3	40.63

Size mm	Pitch mm	No. of Flutes	Hand Taps		No. of Flutes	Spiral Pointed
			Price Each			Price Each
			List No. 773M	List No. 773M Set		List No. 774M
16	2.00	4	38.27	114.81	3	40.63
17	1.50	4	51.40	154.20	—	—
18	1.00	4	51.40	154.20	3	50.87
18	1.50	4	51.40	154.20	3	50.87
18	2.00	4	51.40	154.20	3	50.87
18	2.50	4	51.40	154.20	3	50.87
20	1.00	4	69.89	209.67	3	73.87
20	1.50	4	69.89	209.67	3	73.87
20	2.00	4	69.89	209.67	—	—
20	2.50	4	69.89	209.67	3	73.87
22	1.00	4	72.75	218.25	—	—
22	1.50	4	72.75	218.25	3	97.96
22	2.00	4	72.75	218.25	—	—
22	2.50	4	72.75	218.25	3	97.96
24	1.00	4	93.39	280.17	—	—
24	1.50	4	93.39	280.17	—	—
24	2.00	4	93.39	280.17	3	118.54
24	3.00	4	93.39	280.17	3	118.54
25	1.50	4	163.95	491.85	—	—
26	1.50	4	163.95	491.85	—	—
27	1.50	4	120.50	361.50	—	—
27	2.00	4	120.50	361.50	—	—
27	3.00	4	113.90	361.50	—	—
28	1.50	4	197.19	591.57	—	—
30	1.50	4	197.19	591.57	—	—
30	2.00	4	197.19	591.57	—	—
30	3.00	4	197.19	591.57	—	—
30	3.50	4	197.19	591.57	—	—
32	1.50	4	210.35	631.05	—	—
32	2.00	4	197.19	591.57	—	—
33	1.50	4	268.59	805.77	—	—
33	2.00	4	210.35	631.05	—	—
33	3.50	4	210.35	631.05	—	—
34	1.50	4	268.59	805.77	—	—
35	1.00	4	268.59	805.77	—	—
36	1.50	4	268.59	805.77	—	—
36	2.00	4	268.59	805.77	—	—
36	3.00	4	268.59	805.77	—	—
36	4.00	4	268.59	805.77	—	—
38	1.50	4	354.72	1064.16	—	—
39	3.00	6	354.72	1064.16	—	—
39	4.00	6	354.72	1064.16	—	—
40	1.50	6	456.00	1368.00	—	—
42	1.50	6	456.00	1368.00	—	—
42	2.00	6	456.00	1368.00	—	—
45	1.50	6	456.00	1368.00	—	—
45	4.00	6	456.00	1368.00	—	—
45	4.50	6	456.00	1368.00	—	—
48	1.50	6	485.00	1455.00	—	—
48	3.00	6	485.00	1455.00	—	—
48	5.00	6	485.00	1455.00	—	—
52	1.50	6	599.00	1797.00	—	—
52	5.00	6	599.00	1797.00	—	—

HIGH SPEED STEEL

METRIC HAND TAP SET

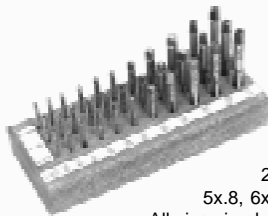

METRIC SIZES SET NO. 773MA

33 Piece Set
Contains 1 piece each of:
2x.4, 2.5x.45, 3x.5, 3.5x.6, 4x.7,
5x.8, 6x1, 7x1, 8x1.25, 10x1.5, 12x1.75
All sizes in plug, bottoming and taper chamfer.
Supplied in wood stand.

SET PRICE — \$ 215.00

HIGH SPEED STEEL

METRIC TAP AND DRILL SET

MADE IN U.S.A.



SET NO. 773S

16 Piece Set
Contains 1 piece of each
Drill and Tap.
Supplied in vinyl pouch.

SET PRICE — \$ 74.50

8 TAPS	8 DRILLS
TAP SIZES	DRILL SIZES
M3 x 0.5	2.50
M3.5 x 0.6	2.90
M4 x 0.7	3.30
M5 x 0.8	4.20
M6 x 1.0	5.00
M8 x 1.25	6.75
M10 x 1.5	8.50
M12 x 1.75	10.25

HIGH SPEED STEEL
SPECIAL THREAD TAPS

GROUND THREAD

■ LIST NO. 779

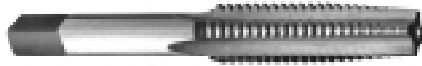

Please specify plug, bottoming or taper chamfer when ordering.

Size	Threads Per Inch Available	Price Each	Size	Threads Per Inch Available	Price Each
0	76	9.40	1-1/16	8, 10, 12, 14, 16, 18, 20, 24, 27, 28, 32	47.50
4	32	9.40	1-1/8	10, 14, 16, 18, 20, 24, 27, 28, 32	49.67
5	32, 36	9.85	1-5/32	14	62.40
6	36, 38, 48, 56, 60	8.50	1-3/16	8, 10, 12, 14, 16, 18, 20, 24, 27, 32	62.40
7	36, 40, 48	9.85	1-1/4	10, 14, 16, 18, 20, 24, 26, 27, 28, 32	62.40
8	24, 30, 40, 48, 56, 60	8.50	1-5/16	6, 11, 24	80.70
9	24	9.85	1-3/8	10, 14, 16, 18, 20, 24	80.70
10	28, 30, 36, 40, 48, 60	8.50	1-7/16	8, 12, 16, 18, 20, 27	106.00
12	32, 36, 40, 48	8.50	1-1/2	4, 10, 14, 16, 18, 20, 24, 28, 32	107.20
14	20, 24	9.85	1-9/16	12, 16, 18, 20	115.00
3/32	50	9.40	1-5/8	5-1/2, 10, 12, 14, 16, 18, 20	118.14
1/8	44, 48	9.40	1-11/16	12, 16, 18, 20, 27	135.00
5/32	32, 36, 40	8.50	1-3/4	5, 6, 10, 12, 14, 16, 18, 20, 24, 36	149.90
3/16	16, 18, 24, 32	8.50	1-13/16	8, 10, 12, 14, 16, 18, 20	165.00
7/32	28, 32, 40	8.50	1-7/8	5, 10, 12, 14, 16, 18, 20, 26	180.12
1/4	18, 22, 24, 26, 27, 30, 32, 36, 38, 40, 48, 56, 60	7.10	1-15/16	8, 10, 12, 16, 18, 20	190.00
9/32	32, 40	7.40	2	6, 10, 14, 16, 18, 20	195.00
5/16	13, 20, 22, 26, 27, 28, 30, 32, 36, 40	7.40	2-1/16	12	206.00
11/32	32	8.35	2-1/8	12, 16, 18	210.36
3/8	13, 14, 18, 20, 22, 24, 27, 28, 30, 32, 36, 40	8.65	2-1/4	4-1/2, 12, 14, 16, 18	225.00
13/32	20, 32	9.56	2-5/16	12, 14, 16, 18	230.00
7/16	12, 16, 18, 24, 26, 27, 28, 32, 40	9.56	2-3/8	12, 16, 18	235.00
15/32	24, 32, 40	10.90	2-1/2	4, 12, 16	290.00
1/2	11, 12, 14, 16, 18, 20, 22, 24, 26, 28, 32, 36, 37, 40, 48, 50	10.90	2-9/16	12	325.00
17/32	32	13.50	2-5/8	8, 12, 16, 18	365.00
9/16	10, 13, 16, 20, 24, 27, 28, 32, 36, 40, 48	13.50	2-3/4	12, 16, 18	449.00
5/8	10, 12, 13, 14, 16, 20, 24, 26, 27, 28, 30, 32, 36, 40, 48	15.20	2-7/8	8, 12, 16	465.00
11/16	12, 18, 20, 24, 27, 30, 32, 36, 40	17.50	3	4, 12, 16, 18	523.00
3/4	8, 11, 11-1/2, 12, 14, 18, 20, 22, 24, 26, 27, 28, 30, 32, 36, 40, 48, 50	18.80	3-1/8	8, 12	570.00
13/16	8, 10, 12, 14, 16, 18, 20, 24, 26, 27, 28, 32, 36	18.80	3-1/4	8, 12	605.00
7/8	8, 10, 11, 12, 16, 18, 20, 24, 26, 27, 28, 30, 32, 36, 40	22.90	3-1/2	4, 8, 12	676.00
15/16	9, 10, 12, 14, 16, 18, 20, 24, 27, 32	24.20	3-3/4	8, 12	789.00
1	7, 9, 10, 11, 16, 18, 20, 24, 26, 27, 28, 30, 32, 36, 40, 50	28.76	4	8, 12	888.00
		32.80	4-1/2	12	1659.00

HIGH SPEED STEEL

EIGHT PITCH TAPS

GROUND THREAD

● LIST NO. 788



Please specify plug, bottoming or taper chamfer when ordering.

Size	No. of Flutes	Price Each
1-1/8	4	85.25
1-1/4	4	101.25
1-3/8	4	130.54
1-1/2	6	151.86
1-5/8	6	195.83
1-3/4	6	218.39
1-7/8	6	258.39
2	6	274.38
2-1/8	6	319.58
2-1/4	6	359.59
2-3/8	6	439.48
2-1/2	6	495.47
2-3/4	6	572.68
3	6	689.21
3-1/2	8	1435.39
4	8	1957.46

HIGH SPEED STEEL

LEFT HAND TAPS

GROUND THREAD, PLUG CHAMFER

▶ LIST NO. 770L



Please specify plug, bottoming or taper chamfer when ordering.

Size	Threads Per Inch	Threads Limits	No. of Flutes	Price Each	Size	Threads Per Inch	Threads Limits	No. of Flutes	Price Each
6	32	H3	3	10.24	5/8	18	H3	4	49.19
6	40	H3	3	10.24	11/16	11	H3	4	54.15
8	32	H3	4	10.24	11/16	16	H3	4	54.15
8	36	H3	4	10.24	3/4	10	H3	4	64.15
10	24	H3	4	10.24	3/4	16	H3	4	64.15
10	32	H3	4	10.24	7/8	9	H4	4	87.09
1/4	20	H3	4	11.99	7/8	14	H4	4	87.09
1/4	28	H3	4	11.99	1	8	H4	4	113.99
1/4	32	H3	4	11.99	1	12	H4	4	113.99
5/16	18	H3	4	13.29	1	14	H4	4	113.99
5/16	24	H3	4	13.29	1-1/8	7	H4	4	191.80
3/8	16	H3	4	17.19	1-1/8	12	H4	4	191.80
3/8	24	H3	4	17.19	1-1/4	7	H4	4	242.14
7/16	14	H3	4	21.99	1-1/4	12	H4	4	242.14
7/16	20	H3	4	21.99	1-3/8	6	H4	4	301.56
1/2	13	H3	4	25.99	1-3/8	12	H4	4	301.56
1/2	20	H3	4	25.99	1-1/2	6	H4	4	350.00
9/16	12	H3	4	38.78	1-1/2	12	H4	4	350.00
9/16	18	H3	4	38.78	1-3/4	8	H4	4	379.00
5/8	11	H3	4	49.19					

COMBINED TAP AND DRILL – THREDRILL

GROUND THREAD — 2 FLUTE



FRACTIONAL SIZES

Nominal Size	Drill Size	Thread Length	Overall Length	Price Each
1/4-20	.2080	13/16	2-1/2	14.99
1/4-28	.2200	23/32	2-1/2	15.99
5/16-18	.2660	31/32	2-27/32	21.99
5/16-24	.2770	7/8	2-27/32	21.99
3/8-16	.3225	1-1/8	3-3/8	25.99
3/8-24	.3395	1	3-3/8	25.99
7/16-14	.3770	1-5/16	3-3/4	33.50
7/16-20	.3955	1-3/16	3-3/4	33.50
1/2-13	.4350	1-15/32	4-1/16	38.70
1/2-20	.4580	1-15/16	4-1/16	38.70
5/8-11	.5750	1-3/4	5	79.50
3/4-10	.7200	2	6	99.00

■ LIST NO. 789

MACHINE SCREW SIZES

Nominal Size	Drill Size	Thread Length	Overall Length	Price Each
4-40	.0910	3/8	1-7/8	14.99
4-48	.0945	11/32	1-7/8	14.99
5-40	.1040	13/32	1-15/16	14.99
6-32	.1115	15/32	2	14.99
6-40	.1170	7/16	2	14.99
8-32	.1375	33/64	2-1/8	14.99
10-24	.1545	5/8	2-3/8	14.99
10-32	.1635	9/16	2-3/8	14.99
12-24	.1805	11/16	2-3/8	14.99
12-28	.1860	21/32	2-3/8	15.99



Designed to drill and tap thru holes in a single pass up to two times the tap diameter. Also can be used on multiple spindle heads with reversing mechanisms.

METRIC SIZES

Nominal Size	Drill Size	Thread Length	Overall Length	Price Each
M3 X .5	.1015	13/32	1-15/16	15.99
M3.5 X .6	.1181	7/16	2	15.99
M4 X .7	.1339	1/2	2-1/8	15.99
M4.5X.75	.1520	7/8	2-3/8	15.99
M5 X .8	.1695	5/8	2-3/8	15.99
M6 X 1	.2031	25/32	2-1/2	15.99
M7 X 1	.2420	15/16	2-27/32	29.99
M8 X 1.25	.2735	15/16	2-27/32	29.99
M10 X 1.5	.3445	1-1/16	3-3/8	33.99
M12 X 1.75	.4134	1-3/8	4-1/16	33.99

PIPE SIZES

Nominal Size	Drill Size	Thread Length	Overall Length	Price Each
1/16-27	.2420	11/16	2-13/16	57.59
1/8-27	.3320	3/4	2-7/8	72.63
1/4-18	.4370	1-1/16	3-5/16	82.44
3/8-18	.5620	1-1/16	3-1/2	95.12
1/2-14	.7030	1-3/8	4-3/8	144.65
3/4-14	.9060	1-3/8	4-9/16	201.98
1-11-1/2	1.1410	1-3/4	5-3/8	303.00

SCREW THREAD INSERT TAPS (STI)

- LIST NO. 770STI — HAND TAP (PLUG OR BOTTOMING CHAMFER)
- LIST NO. 780STI — SPIRAL POINTED TAP (PLUG CHAMFER)

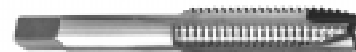

STI Taps are oversized to the extent that the external thread produced will accommodate a helical coil wire screw thread insert, which at final assembly will accept a screw thread of nominal size and pitch.

Size	Threads Per Inch	Thread Limits	Hand Tap		Spiral Pointed	
			No. of Flutes	List No. 770STI	No. of Flutes	List No. 780STI
4	40	H2	3	21.89	2	23.20
6	32	H3	3	21.89	2	23.20
8	32	H3	3	21.89	2	23.20
10	24	H3	3	23.49	2	24.90
10	32	H3	3	23.49	2	24.90
1/4	20	H3	3	24.19	2	25.64
1/4	28	H3	3	24.19	2	25.64
5/16	18	H3	4	26.29	3	27.87
5/16	24	H3	4	26.28	3	27.86

Size	Threads Per Inch	Thread Limits	Hand Tap		Spiral Pointed	
			No. of Flutes	List No. 770STI	No. of Flutes	List No. 780STI
3/8	16	H3	4	32.48	3	34.43
3/8	24	H3	4	32.48	3	34.43
7/16	14	H3	4	40.08	3	42.48
7/16	20	H3	4	40.08	3	42.48
1/2	13	H3	4	45.29	3	48.01
1/2	20	H3	4	45.29	3	48.01
9/16	12	H3	4	49.95	—	—
3/4	10	H3	4	58.89	—	—
1	8	H3	4	72.00	—	—

Please specify plug or bottoming chamfer when ordering hand taps.

ACME TANDEM STYLE TAPS



CLASS 2G

- LIST NO. 787 — RIGHT HAND
- LIST NO. 787L — LEFT HAND

Tandem style tap eliminates the excessive cost of producing Acme threads. It produces threads from a 10° to 30° included angle in a single pass without a lead-screw. The last few threads on the roughing section function as a guide for the short finishing section, which corrects the angles and brings the threads to size.

Size	Threads Per Inch	Thread Length	Overall Length	Price Each	
				List No. 787	List No. 787L
3/8	12	2-1/2	5	87.95	118.00
1/2	10	2-9/16	5	87.95	99.20
5/8	8	3-3/16	6-1/4	98.50	115.30
3/4	6	4-5/16	7-15/16	134.75	156.20
3/4	8	4-5/16	7-15/16	145.00	170.00
7/8	6	4-3/8	8-5/8	157.50	190.10

Size	Threads Per Inch	Thread Length	Overall Length	Price Each	
				List No. 787	List No. 787L
1	5	5-1/4	10-1/8	164.40	199.85
1-1/8	5	5-1/4	10-3/4	176.25	266.96
1-1/4	5	5-1/4	11-1/8	210.00	295.00
1-3/8	4	5-7/8	12-1/4	264.00	328.00
1-1/2	4	5-7/8	12-5/8	281.50	365.00
2	4	6-1/2	14-7/8	335.00	399.00

PIPE TAPS

H.S. TAPER PIPE TAPS

GROUND THREAD

- LIST NO. 790 — NPT QUALITY IMPORT
- LIST NO. 790U — NPT MADE IN U.S.A.
- LIST NO. 790F — NPTF DRYSEAL QUALITY IMPORT



SET NO. 790S

4 piece taper pipe tap set
Contains 1 piece of each:
1/8, 1/4, 3/8, 1/2.

SET PRICE — \$125.00

Taper pipe taps are utilized to thread pipe fittings hence their nominal size is of the pipe being threaded.

Size	Threads Per Inch	Price Each		
		H.S. NPT Taper List No. 790	H.S. USA NPT Taper List No. 790U	H.S. NPTF Taper List No. 790F
1/16	27	21.75	27.70	23.18
1/8	27(sm/sk)	21.75	27.70	—
1/8	27(lg/sk)	21.75	27.70	23.18
1/4	18	23.96	30.60	25.55
3/8	18	31.65	40.40	33.75
1/2	14	50.18	64.00	53.50
3/4	14	70.20	89.65	74.88
1	11-1/2	107.83	135.80	115.00
1-1/4	11-1/2	154.70	195.00	165.00
1-1/2	11-1/2	213.30	261.00	227.50
2	11-1/2	281.08	354.25	299.80
2-1/2	8	508.95	745.00	695.00
3	8	645.00	1050.00	785.00
3-1/2	8	936.68	1110.00	—
4	8	1290.38	1425.00	—

H.S. STRAIGHT TAPER PIPE TAPS

GROUND THREAD

- LIST NO. 791 — NPS QUALITY IMPORT
- LIST NO. 791U — NPS MADE IN U.S.A.
- LIST NO. 791F — NPSF DRYSEAL QUALITY IMPORT



Size	Threads Per Inch	Price Each		
		H.S. NPS Straight List No. 791	H.S. USA NPS Straight List No. 791U	H.S. NPSF Straight List No. 791F
1/16	27	23.35	29.99	24.90
1/8	27	23.35	29.99	24.90
1/4	18	26.10	33.25	27.81
3/8	18	34.10	43.50	36.36
1/2	14	54.38	69.49	57.99
3/4	14	76.23	97.50	81.30
1	11-1/2	115.87	148.00	123.60
1-1/4	11-1/2	155.58	207.00	169.50
1-1/2	11-1/2	213.38	269.00	169.50
2	11-1/2	286.75	385.00	320.00
2-1/2	8	745.00	—	745.00
3	8	1050.00	—	1050.00
3-1/2	8	1110.00	—	—
4	8	1290.00	1425.00	—

H.S. INTERRUPTED THREAD TAPER PIPE TAPS

GROUND THREAD

- LIST NO. 792 — INT/NPT QUALITY IMPORT
- LIST NO. 792U — INT/NPT MADE IN U.S.A.
- LIST NO. 792F — INT/NPTF DRYSEAL QUALITY IMPORT



For tapping tough, or gummy metals that have a tendency to load the tap teeth.

Size	Threads Per Inch	Price Each		
		H.S. INT/NPT List No. 792	H.S. USA INT/NPT List No. 792U	H.S. INT/NPTF List No. 792F
1/16	27	32.63	43.00	34.79
1/8	27	32.63	43.00	34.79
1/4	18	36.10	47.70	38.50
3/8	18	46.43	60.19	49.50
1/2	14	72.38	96.00	77.19
3/4	14	102.83	135.74	109.67
1	11-1/2	161.73	209.80	172.50
1-1/4	11-1/2	230.80	295.00	246.17
1-1/2	11-1/2	309.85	396.29	330.50
2	11-1/2	417.15	533.29	444.96

CARBON TAPER PIPE TAPS

CUT THREAD

- LIST NO. 793 — RIGHT HAND — NPT QUALITY IMPORT
- LIST NO. 793U — RIGHT HAND — NPT MADE IN U.S.A.
- LIST NO. 793L — LEFT HAND — NPT



SET NO. 793S

4 piece carbon RH taper pipe tap set
Contains 1 piece of each:
1/8, 1/4, 3/8, 1/2

SET PRICE — \$53.00

Size	Threads Per Inch	Price Each		
		NPT Straight List No. 793	USA NPT Straight List No. 793U	NPT Left Hand List No. 793L
1/16	27	8.73	10.97	12.09
1/8	27	8.73	10.97	12.09
1/4	18	10.05	12.94	13.91
3/8	18	13.32	16.75	18.46
1/2	14	17.70	22.24	24.50
3/4	14	28.32	35.63	39.26
1	11-1/2	41.72	52.51	57.85
1-1/4	11-1/2	49.23	61.95	68.25
1-1/2	11-1/2	69.50	87.46	96.35
2	11-1/2	106.43	133.93	—
2-1/2	8	199.00	—	—
3	8	269.00	—	—
3-1/2	8	469.00	—	—
4	8	625.00	—	—

LONG REACH NPT PIPE TAPS

GROUND THREAD

● LIST NO. 797 — NPT



Size	Threads Per Inch	Price Each			
		4" OAL	6" OAL	8" OAL	12" OAL
1/16	27	25.50	30.75	—	—
1/8	27	29.50	30.75	37.50	—
1/4	18	—	35.25	39.75	59.00
3/8	18	—	44.17	—	67.67
1/2	14	—	56.75	—	96.95
3/4	14	—	80.75	125.00	149.00
1	11-1/2	—	115.00	175.00	195.00

BRITISH STANDARD PIPE TAPS (BSPT)

GROUND THREAD

● LIST NO. 794

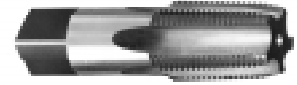

Size	Threads Per Inch	Price Each
1/8	28	34.90
1/4	19	38.83
3/8	19	51.20
1/2	14	81.00
5/8	14	94.90
3/4	14	110.83
1	11	167.40
1-1/4	11	253.13
1-1/2	11	331.88

6" EXTENSION TAPS

GROUND THREAD, PLUG CHAMFER

- LIST NO. 795EX — HAND TAPS
- LIST NO. 796EX — SPIRAL POINTED



Similar to a pulley tap but with a smaller shank diameter for long reach applications.

Size	Threads Per Inch	Price Each	
		List No. 795EX	List No. 796EX
10	24	37.00	38.02
10	32	37.00	38.02
1/4	20	36.15	40.80
5/16	18	37.60	42.40
3/8	16	42.50	47.88
1/2	13	45.00	51.30

SPIRAL FLUTE TAPER PIPE TAPS

GROUND THREAD

● LIST NO. 790SP

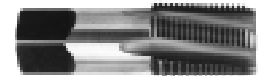

Size	Threads Per Inch	Price Each
1/16	27	43.60
1/8	27	43.60
1/4	18	53.90
3/8	18	67.00
1/2	14	84.50
3/4	14	128.00
1	11-1/2	161.00

These taps have helically ground flutes that lift the chips from the hole being tapped. This action continuously draws chips from the hole and prevents clogging. They are most effective when used in applications that produce long stringy chips.

PULLEY TAPS

GROUND THREAD, PLUG CHAMFER



● LIST NO. 796
SPIRAL POINTED TAPS

Size	Threads Per Inch	No. of Flutes	Price Each
			6" OAL List No. 796
6	32	2	38.02
8	32	2	38.02
10	24	2	38.02
10	32	2	38.02
1/4	20	2	40.80
1/4	28	2	40.80
5/16	18	2	42.40
5/16	24	2	42.40
3/8	16	3	47.88
3/8	24	3	47.88
7/16	14	3	50.16
7/16	20	3	50.16
1/2	13	3	51.30
1/2	20	3	51.30
5/8	11	3	67.26
5/8	18	3	67.26
3/4	10	3	98.50
3/4	16	3	98.50
7/8	14	3	119.00

● LIST NO. 795 — HAND TAPS

Size	Threads Per Inch	No. of Flutes	Price Each	
			6" OAL List No. 795	8" OAL List No. 795
6	32	4	33.35	43.75
8	32	4	33.35	43.75
10	24	4	33.35	43.75
10	32	4	33.35	43.75
1/4	20	4	38.00	46.40
1/4	28	4	38.00	46.40
5/16	18	4	39.85	47.70
5/16	24	4	39.85	47.70
3/8	16	4	44.85	53.30
3/8	24	4	44.85	53.30
7/16	14	4	47.70	62.50
7/16	20	4	47.70	62.50
1/2	13	4	48.10	62.50
1/2	20	4	48.10	62.50
5/8	11	4	64.30	82.00
5/8	18	4	64.30	82.00
3/4	10	4	87.50	107.00
3/4	16	4	87.50	107.00
1-3/8	12	6	—	295.00

● LIST NO. 795 — HAND TAPS

Size	Threads Per Inch	No. of Flutes	Price Each	
			10" OAL List No. 795	12" OAL List No. 795
1/4	20	4	58.00	—
1/4	28	4	58.00	—
5/16	18	4	62.00	—
5/16	24	4	62.00	—
3/8	16	4	66.75	—
3/8	24	4	66.75	—
7/16	14	4	73.50	—
7/16	20	4	73.50	—
1/2	13	4	76.00	94.44
1/2	20	4	76.00	94.44
5/8	11	4	103.00	120.00
5/8	18	4	103.00	120.00
3/4	10	4	121.35	134.00
3/4	16	4	121.35	134.00
7/8	9	4	—	199.00

H.S. THREAD FORMING CHIPLESS TAPS

GROUND THREAD

● LIST NO. 783

Please specify plug or bottoming chamfer.

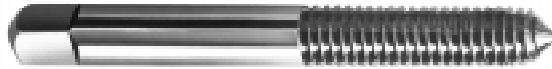

Threading holes with a thread forming tap is a cold forming process accomplished without cutting. Threads produced by this tap are stronger than conventional cut threads because of the swaging and work hardening effect. There are no chips and no cutting edges to become dull and breakdown, therefore tap breakage is minimized. Chipless tapping also eliminates the sometimes costly chip removal from the threaded work. Thread forming taps permit faster tapping speeds.

Size	Threads Per Inch	Price Each
0*	80	19.30
1*	64	19.30
1*	72	19.30
2*	56	19.18
2*	64	19.18
3*	48	19.18
3*	56	19.18
4	40	17.32
4	48	17.32
5	40	17.32
6	32	14.24
6	40	14.24

Size	Threads Per Inch	Price Each
8	32	14.24
8	36	14.24
10	24	14.24
10	32	14.24
12	24	15.10
12	28	15.10
1/4	20	15.10
1/4	28	15.10
5/16	18	16.83
5/16	24	16.83
3/8	16	19.18

Size	Threads Per Inch	Price Each
3/8	24	19.18
7/16	14	26.50
7/16	20	26.50
1/2	13	32.75
1/2	20	32.75
9/16	12	37.50
9/16	18	37.50
5/8	11	46.70
5/8	18	46.70
3/4	10	60.77
3/4	16	60.77

* Available bottoming only.

COBALT SPIRAL POINTED TAPS

GROUND THREAD, PLUG CHAMFER

● LIST NO. 780C



Size	Threads Per Inch	No. of Flutes	Price Each
6	32	2	13.95
8	32	2	13.95
10	24	2	13.95
10	32	2	13.95
1/4	20	3	18.50

Size	Threads Per Inch	No. of Flutes	Price Each
5/16	18	3	20.50
3/8	16	3	23.40
7/16	14	3	33.20
1/2	13	3	38.00
5/8	11	3	84.95



SOLID CARBIDE TAPS

MICRO-GRAIN

GROUND THREAD, H3 LIMIT, PLUG CHAMFER

- LIST NO. CT770— HAND TAPS
- LIST NO. CT780— SPIRAL POINTED TAPS



Size	Threads Per Inch	List No. CT770	List No. CT780
6	32	140.00	147.65
8	32	144.00	151.06
10	24	147.20	153.50
10	32	147.20	153.50
1/4	20	166.65	188.57
5/16	18	190.00	210.00
3/8	16	237.00	274.00
7/16	14	385.00	—
1/2	13	420.00	—
5/8	11	606.50	—

H.S. NUT TAPS

GROUND THREAD

▶ LIST NO. 798 — FOUR FLUTE



Primarily used for threading nuts. Shank of tap is smaller than I.D. of nut allowing nuts to accumulate on the shank. Also used for long reach.

Size	Threads per Inch	Overall Length	Price Each
1/4	20	5	97.99
1/4	28	5	97.99
5/16	18	5-1/2	111.98
5/16	24	5-1/2	111.98
3/8	16	6	136.49
3/8	24	6	136.49
7/16	14	6-1/2	154.89
7/16	20	6-1/2	154.89
1/2	13	7	167.98
1/2	20	7	167.98
3/4	10	9	192.00
1	8	11	295.00

FLOATING DIE AND TAP HOLDER SYSTEM

Cutting external and internal threads is simple, safe, accurate and inexpensive!

- **SIMPLE** — Cut threads on any lathe fitted with a Morse Taper tailstock
- **FASTER** — 4 to 5 times faster than threading with a single point tool
- **ACCURATE** — Improves thread quality with fewer part rejections over hand held method
- **SAFE** — Reduces chance for operator injury

FLOATING DIE HOLDER

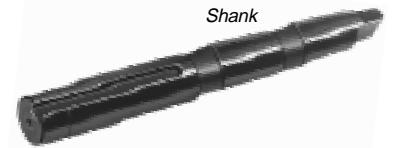

HEADS					SHANKS			
Fits Die O.D.	Max. Thread Length	Fits Shank Number.	Head Number	Price Each	Morse Taper Number	Fits Head Number	Shank Number	Price Each
13/16	2-3/8	FDHS-2T	FDH81-2	56.35	2	FDH1-2, FDH81-2	FDHS-2T	55.20
1	2-3/8	FDHS-2T	FDH1-2	56.35	3	FDH1-34, FDH15-34, FDH2-34	FDHS-3T	73.60
1	2-7/8	FDHS-3T, FDHS-4T	FDH1-34	66.70	4	FDH1-34, FDH15-34, FDH2-34	FDHS-4T	86.25
1-1/2	2-7/8	FDHS-3T, FDHS-4T	FDH15-34	66.70	4	FDH25-4HD5	FDHS-4HD	108.10
2	2-7/8	FDHS-3T, FDHS-4T	FDH2-34	73.60	5	FDH25-4HD5	FDHS-5T	161.00
2-1/2	3-7/8	FDHS-4HD, FDHS-5T	FDH25-4HD5	112.70				

FLOATING TAP HOLDER



HEADS					SHANKS			
Tap Range	Nominal Head Travel	Fits Shank Number.	Head Number	Price Each	Morse Taper Number	Fits Head Number	Shank Number	Price Each
0 — 1/4	2-3/8	FDHS-2T	FTH-014	85.10	2	FTH-014	FDHS-2T	55.20
1/4 — 1/2	2-7/8	FDHS-3T, FDHS-4T	FTH-1412	108.10	3	FTH-1412, FTH-1234	FDHS-3T	73.60
1/2 — 3/4	2-7/8	FDHS-3T, FDHS-4T	FTH-1234	131.10	4	FTH-1412, FTH-1234	FDHS-4T	86.25
3/4 — 1	3-7/8	FDHS-4HD, FDHS-5T	FTH-3410	154.10	4	FTH-3410, FTH-1114, FTH-114112	FDHS-4HD	108.10
1 — 1-1/4	3-7/8	FDHS-4HD, FDHS-5T	FTH-1114	177.10	5	FTH-3410, FTH-1114, FTH-114112	FDHS-5T	161.00
1-1/4 — 1-1/2	3-7/8	FDHS-4HD, FDHS-5T	FTH-114112	201.25				

Simulated tailstock assembly



Simulated tailstock assembly



THREADEX OPERATING INSTRUCTIONS

- Step 1** Select head to fit desired die O.D. or tap range, insert and secure die or tap.
- Step 2** Select appropriate shank and install into lathe tailstock.
- Step 3** Slide head onto shank and advance tailstock within proximity of work piece.
- Step 4** Lock tailstock and advance holder with tailstock crank until head begins to self feed.
- Step 5** Reverse lathe at desired point and reverse tailstock crank a few turns as head is backing off work piece.

STANDARD ROUND ADJUSTABLE SPLIT DIES

SCREW ADJUSTING TYPE

● LIST NO. 751 — RIGHT HAND



For cutting external screw threads either by hand with a die stock or by machine with a floating die holder like the unique Threadex® Floating Die Holder, see page 110. They can be utilized to cut smaller or larger tolerance by turning the adjusting screw.

FRACTIONAL AND MACHINE SCREW SIZES

Size	Threads Per Inch	Price Each
13/16" Diameter		
0	80	23.80
1	64	23.80
1	72	23.80
2	56	23.80
2	64	23.80
3	48	23.80
3	56	23.80
4	40	23.80
4	48	23.80
5	40	23.80
5	44	23.80
6	32	23.80
6	40	23.80
8	32	23.80
8	36	23.80
10	24	23.80
10	32	23.80
12	24	23.80
12	28	23.80
1/4	20	23.80
1/4	28	23.80
5/16	18	23.80
5/16	24	23.80
1" Diameter		
0	80	29.90
1	64	29.90
1	72	29.90
2	56	29.90
2	64	29.90
3	48	29.90
3	56	29.90
4	40	29.90
4	48	29.90
5	40	29.90
5	44	29.90
6	32	29.90
6	40	29.90
8	32	29.90
8	36	29.90
10	24	29.90
10	32	29.90
12	24	29.90

Size	Threads Per Inch	Price Each
1" Diameter		
12	28	29.90
1/4	20	29.90
1/4	28	29.90
5/16	18	29.90
5/16	24	29.90
3/8	16	29.90
3/8	24	29.90
7/16	14	29.90
7/16	20	29.90
1/2	13	29.90
1/2	20	29.90
1-1/2" Diameter		
1/4	20	45.00
1/4	28	45.00
5/16	18	45.00
5/16	24	45.00
3/8	16	45.00
3/8	24	45.00
7/16	14	45.00
7/16	20	45.00
1/2	13	45.00
1/2	20	45.00
9/16	12	45.00
9/16	18	45.00
5/8	11	45.00
5/8	18	45.00
11/16	11	45.00
11/16	16	45.00
3/4	10	45.00
3/4	16	45.00
2" Diameter		
1/4	20	76.90
1/4	28	76.90
5/16	18	76.90
5/16	24	76.90
3/8	16	76.90
3/8	24	76.90
7/16	14	76.90
7/16	20	76.90
1/2	13	76.90
1/2	20	76.90

Size	Threads Per Inch	Price Each
2" Diameter		
9/16	12	76.90
9/16	18	76.90
5/8	11	76.90
5/8	18	76.90
11/16	11	76.90
11/16	16	76.90
3/4	10	76.90
3/4	16	76.90
7/8	9	76.90
7/8	14	76.90
1	8	76.90
1	12	76.90
1	14	76.90
2-1/2" Diameter		
1	8	106.00
1	12	106.00
1	14	106.00
1-1/8	7	106.00
1-1/8	12	106.00
1-1/4	7	106.00
1-1/4	12	106.00
1-3/8	6	106.00
1-3/8	12	106.00
1-1/2	6	106.00
3" Diameter		
1	8	195.00
1	12	195.00
1	14	195.00
1-1/8	7	195.00
1-1/8	12	195.00
1-1/4	7	195.00
1-1/4	12	195.00
1-3/8	6	195.00
1-3/8	12	195.00
1-1/2	6	195.00
1-1/2	12	195.00
1-3/4	5	195.00
1-3/4	12	195.00
2	4-1/2	195.00
2	12	195.00

HIGH SPEED STEEL

NPT/NPS PIPE SIZES— RIGHT HAND

● LIST NO. 760 — NPT

Size	Threads Per Inch	Price Each
1" Diameter		
1/16	27	29.90
1/8	27	29.90
1-1/2" Diameter		
1/8	27	45.00
1/4	18	45.00
3/8	18	45.00
1/2	14	45.00
2" Diameter		
1/4	18	76.90
3/8	18	76.90
1/2	14	76.90
3/4	14	76.90

● LIST NO. 761 — NPS

Size	Threads Per Inch	Price Each
2-1/2" Diameter		
1	11-1/2	106.00
3" Diameter		
1-1/4	11-1/2	195.00
1-1/2	11-1/2	195.00
4" Diameter		
1-1/2	11-1/2	255.00
2	8	255.00
5" Diameter		
2-1/2	8	325.00
3	8	325.00

CARBON STEEL

NPT HEXAGON RETHREADING DIES

● LIST NO. 766 — QUALITY IMPORT
● LIST NO. 766U — MADE IN U.S.A.

Size	Threads Per Inch	Price Each	
		List No. 766	List No. 766U
1/8	27	19.00	27.55
1/4	18	28.40	41.20
3/8	18	37.40	54.25
1/2	14	49.20	71.35
3/4	14	63.60	92.30
1	11-1/2	83.80	121.62
1-1/4	11-1/2	119.50	—
1-1/2	11-1/2	175.00	—
2	11-1/2	355.00	—
2-1/2	8	425.00	—
3	8	460.00	—

STANDARD ROUND ADJUSTABLE METRIC SPLIT DIES



SCREW ADJUSTING TYPE

● LIST NO. 753—RIGHT HAND

For cutting external screw threads either by hand with a die stock or by machine with a floating die holder such as the unique Threadex® Floating Die Holder System. These dies can be utilized to cut smaller or larger tolerances by turning the adjusting screw.

Size mm	Pitch mm	Price Each
13/16" Diameter		
1	.25	23.80
1.2	.25	23.80
1.4	.30	23.80
1.6	.35	23.80
1.7	.35	23.80
1.8	.35	23.80
2	.40	23.80
2.2	.45	23.80
2.3	.40	23.80
2.5	.45	23.80
2.6	.45	23.80
3	.50	23.80
3	.60	23.80
3.5	.60	23.80
4	.50	23.80
4	.70	23.80
4	.75	23.80
4.5	.50	23.80
4.5	.75	23.80
5	.50	23.80
5	.80	23.80
5	.90	23.80
6	.50	23.80
6	.75	23.80
6	1.00	23.80
7	1.00	23.80
8	1.00	23.80
8	1.25	23.80
1" Diameter		
1.6	.35	29.90
1.8	.35	29.90
2	.40	29.90
2.2	.45	29.90
2.3	.40	29.90
2.5	.45	29.90
2.6	.45	29.90
3	.50	29.90
3	.60	29.90
3.5	.60	29.90
4	.50	29.90
4	.70	29.90
4	.75	29.90
4.5	.50	29.90
4.5	.75	29.90
5	.50	29.90
5	.80	29.90
5	.90	29.90
5	1.00	29.90
5.5	.90	29.90
6	.50	29.90
6	.75	29.90
6	1.00	29.90
6	1.25	29.90
6.3	1.00	29.90
7	.75	29.90

Size mm	Pitch mm	Price Each
1" Diameter		
7	1.00	29.90
8	.75	29.90
8	1.00	29.90
8	1.25	29.90
9	1.00	29.90
9	1.25	29.90
10	.75	29.90
10	1.00	29.90
10	1.25	29.90
10	1.50	29.90
11	1.00	29.90
11	1.50	29.90
12	1.00	29.90
12	1.25	29.90
12	1.75	29.90
1-1/2" Diameter		
6	1.00	45.00
7	1.00	45.00
8	1.25	45.00
9	1.00	45.00
9	1.25	45.00
10	.75	45.00
10	1.00	45.00
10	1.25	45.00
10	1.50	45.00
11	1.00	45.00
11	1.50	45.00
12	1.00	45.00
12	1.25	45.00
12	1.50	45.00
12	1.75	45.00
14	1.00	45.00
14	1.25	45.00
14	1.50	45.00
14	2.00	45.00
15	1.50	45.00
16	1.00	45.00
16	1.50	45.00
16	2.00	45.00
17	1.50	45.00
18	1.50	45.00
18	2.00	45.00
18	2.50	45.00
20	1.50	45.00
20	2.00	45.00
20	2.50	45.00
2" Diameter		
15	1.50	76.90
16	1.00	76.90
16	1.50	76.90
16	2.00	76.90
17	1.50	76.90
18	1.50	76.90

Size mm	Pitch mm	Price Each
2" Diameter		
18	2.00	76.90
18	2.50	76.90
20	1.50	76.90
20	2.00	76.90
20	2.50	76.90
22	1.00	76.90
22	1.50	76.90
22	2.00	76.90
22	2.50	76.90
24	1.50	76.90
24	2.00	76.90
24	3.00	76.90
26	1.50	76.90
27	2.00	76.90
27	3.00	76.90
28	1.50	76.90
30	1.50	76.90
30	2.00	76.90
30	3.50	76.90
2-1/2" Diameter		
22	1.00	106.00
22	1.50	106.00
22	2.00	106.00
22	2.50	106.00
24	1.50	106.00
24	2.00	106.00
24	3.00	106.00
26	1.50	106.00
27	2.00	106.00
27	3.00	106.00
28	1.50	106.00
28	2.00	106.00
30	1.50	106.00
30	2.00	106.00
30	3.00	106.00
30	3.50	106.00
33	2.00	106.00
33	3.50	106.00
36	2.00	106.00
36	3.00	106.00
36	4.00	106.00
3" Diameter		
30	2.00	195.00
30	3.00	195.00
30	3.50	195.00
36	3.00	195.00
36	4.00	195.00
39	3.00	195.00
39	4.00	195.00
42	4.50	195.00
45	4.50	195.00
48	5.00	195.00

LEFT HAND ROUND ADJUSTABLE METRIC SPLIT DIES

■ LIST NO. 753LH

Size mm	Pitch mm	Price Each
1" Diameter		
2	.40	29.90
2.5	.45	29.90
3	.50	29.90
3.5	.60	29.90
4	.70	29.90
5	.80	29.90
6	1.00	29.90

Size mm	Pitch mm	Price Each
1" Diameter		
7	1.00	29.90
8	1.25	29.90
10	1.25	29.90
10	1.50	29.90
10	1.75	29.90
12	1.25	29.90
12	1.75	29.90

Size mm	Pitch mm	Price Each
1-1/2" Diameter		
12	1.25	45.00
12	1.75	45.00
14	1.50	45.00
14	2.00	45.00
16	1.50	45.00

Size mm	Pitch mm	Price Each
1-1/2" Diameter		
16	2.00	45.00
18	1.50	45.00
18	2.50	45.00
20	1.50	45.00
20	2.50	45.00



LEFT HAND ROUND ADJUSTABLE SPLIT DIES

● LIST NO. 751LH

FRACTIONAL AND MACHINE SCREW SIZES



Size	Threads Per Inch	Price Each
13/16" Diameter		
0	80	28.50
2	56	28.50
2	64	28.50
4	40	28.50
5	40	28.50
6	32	28.50
8	32	28.50
10	24	28.50

Size	Threads Per Inch	Price Each
1" Diameter		
3	56	35.00
4	40	35.00
4	48	35.00
5	40	35.00
5	44	35.00
6	32	35.00
6	40	35.00
8	32	35.00
8	36	35.00
10	24	35.00
10	32	35.00
12	24	35.00
12	28	35.00
1/4	20	35.00
1/4	28	35.00
5/16	18	35.00
5/16	24	35.00
3/8	16	35.00
3/8	24	35.00
7/16	14	35.00
7/16	20	35.00
1/2	13	35.00
1/2	20	35.00
9/16	12	35.00

Size	Threads Per Inch	Price Each
1-1/2" Diameter		
1/4	20	54.00
1/4	28	54.00
5/16	18	54.00
5/16	24	54.00
3/8	16	54.00
3/8	24	54.00
7/16	14	54.00
7/16	20	54.00
1/2	13	54.00
1/2	20	54.00
9/16	12	54.00
9/16	18	54.00
5/8	11	54.00
5/8	18	54.00
11/16	11	54.00
11/16	16	54.00
3/4	10	54.00
3/4	16	54.00

Size	Threads Per Inch	Price Each
2" Diameter		
3/4	10	92.00
3/4	16	92.00
7/8	9	92.00
7/8	14	92.00
1	8	92.00
1	12	92.00
1	14	92.00

Size	Threads Per Inch	Price Each
2-1/2" Diameter		
1-1/8	7	127.50
1-1/8	12	127.50
1-1/4	7	127.50
1-1/4	12	127.50
1-3/8	6	127.50
1-3/8	12	127.50
1-1/2	6	127.50
1-1/2	12	127.50

Size	Threads Per Inch	Price Each
3" Diameter		
1-1/2	6	234.00
1-1/2	12	234.00
1-3/4	5	234.00
2	4-1/2	234.00

CARBON STEEL

SOLID SQUARE PIPE DIES

▶ LIST NO. 768



Size	Threads Per Inch	Price Each			
		2" Square 1/2" Deep	2-1/2" Square 3/4" Deep	3" Square 3/4" Deep	4" Square 1" Deep
1/8	27	43.66	52.90	—	—
1/4	18	43.66	52.90	—	—
3/8	18	43.66	52.90	—	—
1/2	14	43.66	52.90	89.70	—
3/4	14	—	52.90	89.70	—
1	11-1/2	—	52.90	89.70	98.50
1-1/4	11-1/2	—	—	89.70	98.50
1-1/2	11-1/2	—	—	—	98.50
2	11-1/2	—	—	—	98.50

CARBON STEEL

ADJUSTABLE 2-PIECE DIE

▶ LIST NO. 764



Easy to sharpen and allows for a wide range of adjustment. Ideal for threading or thread repair work.

Size	Threads Per Inch	For use with collet No.	Price per Two Piece Die
1/4	20	1 or 5	24.90
1/4	28	1 or 5	24.90
5/16	18	1 or 5	24.90
5/16	24	1 or 5	24.90
3/8	16	1 or 5	29.50
3/8	24	1 or 5	29.50
7/16	14	1 or 5	29.75
7/16	20	1 or 5	29.75
1/2	13	1 or 5	35.85
1/2	20	1 or 5	35.85
9/16	12	5	36.50
9/16	18	5	36.50
5/8	11	5 or 20	41.65
5/8	18	5 or 20	41.65
11/16	11	5 or 20	46.50
3/4	10	5 or 20	61.00
3/4	16	5 or 20	61.00
7/8	9	5, 20 or 25	62.50
7/8	14	5, 20 or 25	62.50
1	8	5, 20 or 25	65.85
1	12	5, 20 or 25	65.85
1	14	5, 20 or 25	65.85

Please specify Collet No. when ordering.

ROUND ADJUSTABLE SPECIAL THREAD SPLIT DIES



■ LIST NO. 759 — RIGHT HAND

Size	Threads Per Inch	Price Each
13/16" Diameter		
4	36	28.50
5	48	28.50
6	36, 48	28.50
8	40	28.50
10	36, 40, 48, 56, 64	28.50
12	32	28.50
7/32	32	28.50
9/32	32	28.50
1" Diameter		
4	36, 56, 60, 64	29.90
5	48, 56, 64	29.90
6	30, 36, 48, 56	29.90
8	24, 30, 40, 48, 56, 64	29.90
10	26, 27, 28, 30, 36, 40, 48, 56, 64, 80	29.90
12	26, 27, 30, 32, 36, 40, 48, 50	29.90
5/32	40	29.90
7/32	24, 32, 40	29.90
14	27, 28, 30, 32	29.90
1/4	14, 16, 18, 22, 24, 26, 27, 30, 32, 36, 40, 48, 56, 64, 80	29.90
5/16	16, 20, 22, 26, 27, 28, 30, 32, 36, 40, 48, 56, 64, 80	29.90
3/8	14, 18, 20, 22, 26, 27, 28, 30, 32, 36, 40, 48, 56, 64, 72	29.90
13/32	32	29.90
7/16	12, 16, 18, 24, 27, 28, 30, 32, 36, 40, 48	29.90
1/2	12, 14, 16, 18, 22, 24, 27, 28, 30, 32, 36, 40, 48, 56	29.90
1-1/2" Diameter		
1/4	22, 24, 27, 30, 32, 36, 40, 48	45.00
5/16	16, 20, 22, 27, 28, 30, 32, 36, 40, 48	45.00
3/8	14, 18, 20, 22, 26, 27, 28, 30, 32, 36, 40, 48	45.00
7/16	12, 16, 18, 22, 24, 27, 28, 30, 32, 36, 40, 48	45.00
15/32	32	45.00
1/2	12, 14, 16, 18, 28, 22, 24, 27, 28, 30, 32, 36, 40, 48	45.00
9/16	14, 16, 20, 22, 24, 27, 28, 30, 32, 36, 40, 48	45.00
5/8	10, 12, 14, 16, 20, 22, 24, 26, 27, 28, 30, 32, 36, 40, 48	45.00
11/16	12, 14, 18, 20, 24, 27, 32, 36, 40	45.00
3/4	11-1/2, 12, 14, 18, 20, 24, 27, 28, 30, 32, 36, 40, 48	45.00
13/16	10, 12, 16, 20, 24, 28, 32	45.00
2" Diameter		
7/16	18, 24	76.90
1/2	12, 16, 18, 24, 27, 28, 30, 32	76.90
9/16	14, 20, 24, 27, 28, 30, 32, 36	76.90
5/8	10, 12, 14, 16, 20, 24, 27, 28, 30, 32, 40	76.90
11/16	12, 14, 18, 20, 24, 27, 28, 32, 36, 40	76.90

Inquire for sizes not shown.

Size	Threads Per Inch	Price Each
2" Diameter		
3/4	12, 14, 18, 20, 24, 27, 28, 32, 36, 40	76.90
13/16	10, 12, 14, 16, 18, 20, 24, 27, 28, 30, 32, 36, 40	76.90
7/8	10, 12, 16, 18, 20, 24, 27, 28, 30, 32, 36, 40, 48	76.90
15/16	10, 12, 14, 16, 18, 20, 24, 27, 28, 30, 32	76.90
1	10, 16, 18, 20, 24, 26, 27, 28, 30, 32, 36, 40, 48, 56	76.90
1-1/16	12, 14, 16, 18	76.90
2-1/2" Diameter		
1	10, 16, 18, 20, 24, 26, 27, 28, 32	106.00
1-1/16	7, 8, 10, 12, 14, 16, 18, 20, 24, 28	106.00
1-1/8	8, 10, 14, 16, 17, 20, 24, 27, 28, 30, 32	106.00
1-3/16	7, 8, 10, 12, 14, 16, 18, 20, 24, 27, 28, 32	106.00
1-1/4	6, 8, 10, 14, 16, 18, 20, 24, 26, 27, 28, 30, 32, 36, 40	106.00
1-5/16	8, 12, 14, 16, 18, 20, 24, 27, 32	106.00
1-3/8	7, 8, 10, 14, 16, 18, 20, 24, 27, 32	106.00
1-7/16	6, 8, 12, 16, 18, 20	106.00
1-1/2	7, 8, 10, 14, 16, 18, 20, 24, 27, 30, 32	106.00
3" Diameter		
1	10, 16, 18, 20, 24	195.00
1-1/16	8, 10, 12, 14, 16, 18, 20, 24	195.00
1-1/8	8, 10, 14, 16, 18, 20, 24	195.00
1-3/16	8, 12, 16	195.00
1-1/4	6, 8, 10, 14, 16, 18, 20, 24	195.00
1-5/16	8, 10, 12, 14, 16, 18, 20	195.00
1-3/8	8, 10, 14, 16, 18, 20, 24	195.00
1-7/16	6, 8, 12, 16, 18	195.00
1-1/2	6, 8, 10, 14, 16, 18, 20, 24	195.00
1-9/16	6, 8, 12, 16, 18, 20, 32	195.00
1-5/8	5, 5-1/2, 6, 8, 10, 12, 14, 16, 18, 20	195.00
1-11/16	6, 8, 12, 16, 18	195.00
1-3/4	5-1/2, 6, 8, 10, 14, 16, 18, 20, 24	195.00
1-13/16	8, 10, 12, 14, 16, 18, 20	195.00
1-7/8	5, 5-1/2, 6, 8, 10, 12, 14, 16, 18, 20	195.00
1-15/16	10, 12, 14, 16, 18, 20	195.00
2	4, 6, 8, 10, 14, 16, 18, 20, 24	195.00
4" Diameter		
2-1/8	18	240.00
2-1/4	4-1/2, 8, 12, 16	240.00
2-3/8	16	240.00
2-1/2	4, 8, 12	240.00
2-3/4	12, 16	240.00
3	8, 12	240.00

CARBON STEEL

HEXAGON SPECIAL RETHREADING DIES



■ LIST NO. 769 — RIGHT HAND

Size	Threads Per Inch Available	Price Each
1/4	24, 27, 32, 36, 40, 48	14.28
5/16	16, 20, 27, 32, 40	15.75
3/8	18, 20, 27, 32, 40	16.59
7/16	24, 28, 32, 40	18.69
1/2	16, 18, 24, 28, 32, 40	19.95
9/16	16, 20, 24, 32	21.21
5/8	16, 20, 24, 32	24.57
11/16	18, 20, 24	27.51
3/4	18, 20, 24, 32	32.55
13/16	16, 20, 24, 32	36.54
7/8	16, 18, 20, 24, 32, 40	36.54
15/16	14, 16, 18, 20	41.79
1	10, 16, 18, 20, 24, 32	41.79
1-1/16	8, 12, 16, 18	48.93
1-1/8	8, 16, 18, 20	48.93
1-3/16	8, 10, 12, 18	58.80
1-1/4	5, 8, 10, 16, 18, 20	58.80
1-5/16	8, 12, 18	62.79
1-3/8	7, 8, 10, 16, 18, 20	62.79
1-7/16	6, 8, 12, 16, 18	68.04
1-1/2	8, 14, 16, 18, 20	68.04
1-9/16	12, 16, 18, 20	103.85

Size	Threads Per Inch Available	Price Each
1-5/8	4, 5, 5-1/2, 6, 8, 10, 12, 14, 16, 18	103.85
1-11/16	18	125.48
1-3/4	5-1/2, 6, 8, 10, 14, 16, 18, 20	125.48
1-13/16	12, 18	183.96
1-7/8	5, 8, 12, 16, 18	183.96
2	4, 8, 10, 12, 14, 16, 18, 20, 24	183.96
2-1/8	6, 8, 12, 14, 16, 18	252.00
2-1/4	4, 6, 8, 10, 12, 14, 16, 18	252.00
2-3/8	4, 8, 10, 12, 14, 18	294.00
2-1/2	4-1/2, 5, 6, 8, 10, 12, 14, 16, 18	294.00
2-5/8	6, 8, 12, 14, 16	399.00
2-3/4	6, 8, 10, 12, 14, 18	399.00
2-7/8	6, 8, 12	439.16
3	8, 12	439.16
3-1/8	4, 8, 12	552.04
3-1/4	5, 8, 12	552.04
3-3/8	4, 8, 12	596.40
3-1/2	8, 12	596.40
3-5/8	4, 8, 12	640.50
3-3/4	8, 12	640.50
3-7/8	4, 8, 12	708.75
4	8, 12	708.75

HEXAGON RETHREADING DIES

- LIST NO. 765 — RIGHT HAND
- LIST NO. 765U — RIGHT HAND, MADE IN U.S.A.
- LIST NO. 765LH — LEFT HAND



For rethreading, damaged, jammed or rusty threads. No special holder is required for these dies. Any wrench large enough will suffice.

FRACTIONAL AND MACHINE SCREW SIZES

Size	Threads Per Inch	Price Each		
		R.H. List No. 765	R.H. List No. 765U	L.H. List No. 765LH
2	56	13.60	—	—
4	36	13.60	—	—
4	40	13.60	—	—
4	48	13.60	—	—
5	40	13.60	—	—
5	44	13.60	—	—
6	32	13.60	19.70	—
6	40	13.60	19.70	—
8	32	13.60	19.70	—
8	36	13.60	19.70	—
10	24	13.60	19.70	—
10	32	13.60	19.70	—
12	24	13.60	19.70	—
12	28	13.60	19.70	—
1/4	20	13.60	19.70	14.95
1/4	28	13.60	19.70	14.95
5/16	18	15.00	21.75	16.50
5/16	24	15.00	21.75	16.50
3/8	16	15.80	22.90	18.50

Size	Threads Per Inch	Price Each		
		R.H. List No. 765	R.H. List No. 765U	L.H. List No. 765LH
3/8	24	15.80	22.90	18.50
7/16	14	17.80	25.80	19.90
7/16	20	17.80	25.80	19.90
1/2	13	19.00	27.55	23.50
1/2	20	19.00	27.55	23.50
9/16	12	20.20	29.30	26.50
9/16	18	20.20	29.30	26.50
5/8	11	23.40	33.95	29.00
5/8	18	23.40	33.95	29.00
11/16	11	26.20	38.00	34.33
11/16	16	26.20	38.00	34.33
3/4	10	31.00	44.95	39.27
3/4	16	31.00	44.95	39.27
7/8	9	34.80	50.50	44.13
7/8	14	34.80	50.50	44.13
1	8	39.80	57.75	49.93
1	12	39.80	57.75	49.93
1	14	39.80	57.75	49.93
1-1/8	7	46.60	—	65.00

Size	Threads Per Inch	Price Each	
		R.H. List No. 765	L.H. List No. 765LH
1-1/8	12	46.60	65.00
1-1/4	7	56.00	79.20
1-1/4	12	56.00	79.20
1-3/8	6	59.80	89.00
1-3/8	12	59.80	89.00
1-1/2	6	64.80	109.50
1-1/2	12	64.80	109.50
1-5/8	5-1/2	98.80	—
1-3/4	5	119.50	186.70
2	4-1/2	149.35	252.70
2-1/4	4-1/2	240.00	—
2-1/2	4	280.00	—
2-3/4	4	380.00	—
3	4	418.25	—
3-1/4	4	525.75	—
3-1/2	4	568.00	—
3-3/4	4	610.00	—
4	4	675.00	—

- LIST NO. 767 — RIGHT HAND

METRIC SIZES

Size mm	Pitch mm	Price Each	Size mm	Pitch mm	Price Each	Size mm	Pitch mm	Price Each	Size mm	Pitch mm	Price Each	Size mm	Pitch mm	Price Each
3	.50	12.74	9	1.25	15.76	15	2.00	23.28	22	2.50	44.72	33	2.00	66.21
3	.60	12.74	10	.50	17.74	16	.50	23.28	22	3.00	44.72	33	3.50	66.21
3.5	.50	12.74	10	.75	17.74	16	.75	23.28	23	2.00	44.72	34	1.50	72.92
3.5	.60	12.74	10	1.00	17.74	16	1.00	23.28	23	2.50	44.72	35	1.50	72.92
4	.50	12.74	10	1.25	17.74	16	1.25	23.28	24	1.00	44.72	36	1.50	72.92
4	.70	12.74	10	1.50	17.74	16	1.50	23.28	24	1.50	44.72	36	2.00	72.92
4	.75	12.74	11	.50	17.74	16	2.00	23.28	24	2.00	44.72	36	3.00	72.92
4.5	.50	12.74	11	.75	17.74	17	1.50	34.82	24	2.50	44.72	36	4.00	72.92
4.5	.75	12.74	11	1.00	17.74	17	2.00	34.82	24	3.00	44.72	38	1.50	79.80
5	.50	12.74	11	1.25	17.74	18	.50	34.82	25	1.50	49.74	39	1.50	79.80
5	.75	12.74	11	1.50	17.74	18	1.00	34.82	25	2.00	49.74	39	3.00	79.80
5	.80	12.74	12	.50	19.06	18	1.50	34.82	26	1.50	49.74	39	4.00	79.80
5	.90	13.74	12	.75	19.06	18	2.00	34.82	26	2.00	49.74	40	1.50	99.16
6	.50	13.42	12	1.00	19.06	18	2.50	34.82	27	1.00	49.74	42	1.50	99.16
6	.75	13.42	12	1.25	19.06	19	1.50	34.82	27	1.50	49.74	42	3.00	99.16
6	1.00	13.42	12	1.50	19.06	19	2.00	34.82	27	2.00	49.74	42	4.50	99.16
6.3	1.00	13.42	12	1.75	19.06	20	1.00	34.82	27	3.00	49.74	45	1.50	120.00
7	.50	15.10	13	1.50	20.29	20	1.25	34.82	28	1.50	60.18	45	3.00	120.00
7	.75	15.10	13	2.00	20.29	20	1.50	34.82	28	2.00	60.18	45	4.50	120.00
7	1.00	15.10	14	.50	20.29	20	2.00	34.82	30	1.00	60.18	48	1.50	140.00
8	.50	15.10	14	.75	20.29	20	2.50	34.82	30	1.50	60.18	48	3.00	140.00
8	.75	15.10	14	1.00	20.29	21	1.50	44.72	30	2.00	60.18	48	5.00	140.00
8	1.00	15.10	14	1.25	20.29	21	2.50	44.72	30	3.00	60.18	50	1.50	150.00
8	1.25	15.10	14	1.50	20.29	22	1.00	44.72	30	3.50	60.18	52	1.50	189.85
9	.50	15.76	14	2.00	20.29	22	1.50	44.72	32	1.50	66.21	52	3.00	189.85
9	.75	15.76	15	1.50	23.28	22	2.00	44.72	33	1.50	66.21	52	5.00	189.85
9	1.00	15.76												

HIGH SPEED HEXAGON RETHREADING DIES

- LIST NO. 765HS

Threading Dies are designed for tough cutting applications of all types of external threads, such as threading rods, bolts and studs.



Size	Threads Per Inch	Price Each	Size	Threads Per Inch	Price Each	Size	Threads Per Inch	Price Each	Size	Threads Per Inch	Price Each	Size	Threads Per Inch	Price Each
1/4	20	19.00	7/16	14	26.70	5/8	11	36.75	1	8	62.50	1-1/4	12	115.00
1/4	28	19.00	7/16	20	26.70	5/8	18	36.75	1	12	62.50	1-3/8	6	135.00
5/16	18	22.00	1/2	13	28.50	3/4	10	46.50	1	14	62.50	1-3/8	12	135.00
5/16	24	22.00	1/2	20	28.50	3/4	16	46.50	1-1/8	7	95.00	1-1/2	6	175.00
3/8	16	23.70	9/16	12	32.30	7/8	9	52.90	1-1/8	12	95.00	1-1/2	12	175.00
3/8	24	23.70	9/16	18	32.30	7/8	14	52.90	1-1/4	7	115.00			

TAP AND DIE SETS

◆ **SET NO. 777P — \$159.00**

CARBON PIPE TAP & HEX DIE SET	
Description	Tap and Dies Included Sizes
12 Piece Carbon Pipe Tap & Hexagon Pipe Die Set	1/8 NPT 1/4 3/8 1/2 3/4 1"



◆ **SET NO. 777X — \$299.00**

CARBON FRACTIONAL & METRIC TAP & HEX DIE SET			
Description	Tap and Dies Included Sizes		Tools Included
76 Piece Carbon Fractional and Metric Tap & Hex Die Set	4-40 6-32 8-32 10-24 10-32 12-24 1/4-20 1/4-28 5/16-18 5/16-24 3/8-16 3/8-24 7/16-14 7/16-20 1/2-13 1/2-20 1/8-27 NPT	3x0.50 4x0.70 4x0.75 5x0.80 5x0.90 6x1.00 7x1.00 8x1.00 8x1.25 9x1.00 9x1.25 10x1.25 10x1.50 11x1.50 12x1.50 12x1.75 1/8-28 BSP	<ul style="list-style-type: none"> •1 Die stock •1 Plain Die stock •1 T-Tap Wrench •1 Hex Nut with 3/8 Sq. Drive •1 Hex Nut Screw Pitch Gauge (Metric) •1 Screw Pitch Gauge •1 Screwdriver •2 Adj. Handle Tap Wrenches

◆ **SET NO. 777CD — \$129.00**

CARBON TAP & ROUND ADJUSTABLE DIE SET			
Description	Tap and Dies Included Sizes		Tools Included
45 Piece Fractional Carbon Tap & Die Set	1/4-20 1/4-28 5/16-18 5/16-24 3/8-16 3/8-24 7/16-14 7/16-20 1/2-13 1/2-20	9/16-12 9/16-18 5/8-11 5/8-18 3/4-10 3/4-16 7/8-9 7/8-14 1-8 1-14	<ul style="list-style-type: none"> •2 Tap Wrenches (1/4"-1/2" "T" Type) (1/4"-1" Large Screw Type) •2" Diameter Die Stock •1-1/2" Adapter •1 Screwdriver

◆ **SET NO. 777HC — \$179.00**

CARBON TAP & HEX DIE SET			
Description	Tap and Dies Included Sizes		Tools Included
41 Piece Carbon Tap & Hex Die Set #6 to 3/4 NC	6-32 8-32 10-24 12-24 1/4-20 5/16-18	3/8-16 7/16-14 1/2-13 9/16-12 5/8-11 3/4-10	<ul style="list-style-type: none"> •2 Tap Wrenches •2 Die Stocks •1 T-handle

◆ **SET NO. 778T — \$159.00**

HIGH SPEED METRIC TAP & ROUND ADJUSTABLE DIE SET			
Description	Tap and Dies Included Sizes		Tools Included
23 Piece High Speed Metric Tap & Round Adj. Die Set	5x0.80 5x0.90 6x0.75 6x1.00 8x1.00	8x1.25 10x1.25 10x1.50 12x1.50 12x1.75	<ul style="list-style-type: none"> •1 Tap Wrench •2 Piece Die Stocks (1"OD, 1-1/2"OD)

◆ **SET NO. 777S — \$299.00**

HIGH SPEED TAP & ROUND ADJUSTABLE DIE SET			
Description	Tap and Dies Included Sizes		Tools Included
40 Piece Inch Tap & Round Adj. Die Set	4-40 6-32 8-32 10-24 10-32 12-24 1/4-20 1/4-28	5/16-18 5/16-24 3/8-16 3/8-24 7/16-14 7/16-20 1/2-13 1/2-20 1/8 NPT	<ul style="list-style-type: none"> •3 Tap Wrenches •1 Die Stock (1"OD) •1 Screw Pitch Gauge •1 Screwdriver

◆ **SET NO. 778S — \$299.00**

HIGH SPEED METRIC TAP & ROUND ADJUSTABLE DIE SET			
Description	Tap and Dies Included Sizes		Tools Included
36 Piece Metric Tap & Round Adj. Die Set	3x0.50 3x0.60 4x0.70 4x0.75 5x0.80 6x1.00 7x1.00 8x1.00	8x1.25 10x1.25 10x1.50 11x1.50 12x1.50 12x1.75 1/8 NPT	<ul style="list-style-type: none"> •3 Tap Wrenches •1 Piece Die Stock(1"OD) •1 Screw Pitch Gauge •1 Screwdriver

◆ **SET NO. 777CB — \$99.00**

CARBON TAP & ROUND ADJUSTABLE DIE SET			
Description	Tap and Dies Included Sizes		Tools Included
40 Piece Inch Tap & Round Adj. Die Set	4-40 6-32 8-32 10-24 10-32 12-24 1/4-20 1/4-28	5/16-18 5/16-24 3/8-16 3/8-24 7/16-14 7/16-20 1/2-13 1/2-20 1/8 NPT	<ul style="list-style-type: none"> •3 Tap Wrenches •1 Die Stock (1"OD) •1 Screw Pitch Gauge •1 Screwdriver

◆ **SET NO. 778CB — \$129.00**

CARBON METRIC TAP & ROUND ADJUSTABLE DIE SET			
Description	Tap and Dies Included Sizes		Tools Included
36 Piece Metric Tap & Round Adj. Die Set	3x0.50 3x0.60 4x0.70 4x0.75 5x0.80 6x1.00 7x1.00 8x1.00	8x1.25 10x1.25 10x1.50 11x1.50 12x1.50 12x1.75 1/8 NPT	<ul style="list-style-type: none"> •3 Tap Wrenches •1 Piece Die Stock(1"OD) •1 Screw Pitch Gauge •1 Screwdriver

SCREW EXTRACTORS

SETS

Made in U.S.A.

● EXL SERIES — SPIRAL FLUTE MADE IN U.S.A.



● EXT SERIES — STRAIGHT FLUTE MADE IN U.S.A.



For removing broken screws, studs, pipe fittings, etc., without damaging the threads.

Size	For Screws & Bolts, Sizes	Pipe Size	USA Spiral Tool No.	Price Each	USA Straight Tool No.	Price Each
1	3/16 - 1/4	—	EXL1	2.20	EXT1	2.20
2	1/4 - 5/16	—	EXL2	2.40	EXT2	2.40
3	5/16 - 7/16	—	EXL3	2.90	EXT3	2.90
4	7/16 - 9/16	1/8	EXL4	2.99	EXT4	2.99
5	9/16 - 3/4	1/4	EXL5	3.75	EXT5	3.75
6	3/4 - 1	3/8	EXL6	8.60	—	—
7	1 - 1-3/8	1/2	EXL7	13.85	—	—
8	1-3/8 - 1-3/4	3/4	EXL8	18.90	—	—
9	1-3/4 - 2-1/8	1	EXL9	32.70	—	—
10	2-1/8 - 2-1/2	1-1/4	EXL10	45.00	—	—
11	2-1/2 - 3	1-1/2	EXL11	68.50	—	—
12	3 - 3-1/2	2	EXL12	109.00	—	—



SET NO. EXL15

5 Piece Set
Contains 1 piece of each:
Spiral Flute, #1 thru #5
Supplied in a vinyl pouch.

SET PRICE — \$13.95

SET NO. EXL69

4 Piece Set
Contains 1 piece of each:
Spiral Flute, #6 thru #9

SET PRICE — \$73.95

SET NO. EXT15

5 Piece Set
Contains 1 piece of each:
Straight Flute, #1 thru #5
Supplied in a vinyl pouch.

SET PRICE — \$13.95

SET NO. EXL19

9 Piece Set
Contains 1 piece of each:
Spiral Flute, #1 thru #9

SET PRICE — \$87.95

● 10 PIECE LEFT HAND DRILL AND SCREW EXTRACTOR SET

SET NO. EXL10

Contains 1 piece each
Left Hand Jobber Drills:
5/64, 7/64, 5/32, 1/4, 3/8
Screw Extractors: 1, 2, 3, 4, 5

SET PRICE — \$49.50



● EXE SERIES — ECONOMY IMPORTED

Size	For Screws & Bolts, Sizes	Economy Tool No.	Price Each
1	3/16 - 1/4	EXE1	1.25
2	1/4 - 5/16	EXE2	1.40
3	5/16 - 7/16	EXE3	1.50
4	7/16 - 9/16	EXE4	1.70
5	9/16 - 3/4	EXE5	2.75
6	3/4 - 1	EXE6	4.95
7	1 - 1-3/8	EXE7	8.50
8	1-3/8 - 1-3/4	EXE8	12.00
9	1-3/4 - 2-1/8	EXE9	19.75
10	2-1/8 - 2-1/2	EXE10	29.00
11	2-1/2 - 3	EXE11	44.50
12	3 - 3-1/2	EXE12	69.00

◆ SELF ALIGNING TAP & REAMER HOLDER SET

TOOL NO. TSA1

- Hardened jaws hold taps and reamers true, preventing breakage
- Set consists of tapping guide, tap holder and jaw "A" for 1/4" capacity taps and jaw "B" for 1/4 - 1/2" taps

PRICE EACH — \$27.75



● HEX DIE ADAPTERS

Hexagon die adapters are utilized when the space limitations do not allow the use of die stocks. These adapters convert round dies to hexagon dies.



OD Size Round Die	Hex Size Across the Flats	Thickness	Tool No.	Price Each
13/16	1-1/16	11/32	TWA1	27.00
1	1-1/4	15/32	TWA2	27.00
1-1/2	1-31/32	13/16	TWA3	28.20
2	2-9/16	3/4	TWA4	29.40
2-1/2	3	29/32	TWA5	44.40
3	3-1/2	1-1/4	TWA6	65.00

● ROUND DIE STOCKS



For holding adjustable round split dies.

Tool No.	Diameter of Die	Price Each
TWS1	5/8	19.00
TWS2	13/16	19.00
TWS3	1	22.00
TWS4	1-1/2	34.00
TWS5	2	44.10
TWS6	2-1/2	61.20
TWS7	3	102.00
TWS8	4	169.00
TWS9	5	275.00

● HEX DIE STOCK

For holding adjustable hex die stock.

Hex Size	Diameter Across the Flats	Tool No.	Price Each
1	1	TWHX1	15.00
1-7/16	1-7/16	TWHX2	34.00

● DIE HOLDER

Can be used safely for threading shafts on lathes, milling machines and tapping heads.



Size	Shank Size	Tool No.	Price Each
13/16	1/2	TWF1	29.00
1	1/2	TWF2	29.00
1-1/2	3/4	TWF3	44.00

◆ ADJUSTABLE TAP AND REAMER WRENCHES

STRAIGHT TYPE



Hardened and tempered jaws used for taps or reamers.

Holding Capacity				Tool No.	Price Each
Fractional Tap Sizes	Machine Screw Tap Sizes	Pipe Tap Sizes	Hand Reamer Sizes		
1/16 - 1/4	0-14	—	1/8 - 21/64	TW0	14.88
1/16 - 3/8	0-14	—	1/8 - 25/64	TW4	20.00
5/32 - 1/2	8-14	—	11/64 - 7/16	TW5	28.31
5/32 - 3/4	8-14	1/8	11/64 - 41/64	TW6	28.31
1/4 - 1-1/8	—	1/8 - 3/4	9/32 - 29/32	TW7	31.56
1/2 - 1-3/8	—	1/8 - 1	3/8 - 1-5/32	TW75	39.80
3/4 - 1-5/8	—	3/8 - 1-1/4	37/64 - 1-11/32	TW8	94.37
7/8 - 2	—	1 - 2	3/4 - 1-1/2	TW10	111.25
1 - 2-1/2	—	3/4 - 2	7/8 - 2-1/8	TW22	122.50

◆ SCREW PITCH GAGES



Tool No.	Range	No. of Leaves	Thread	Price Each
TSP-1	#4 - #42	30	American	11.50
TSP-2	0.25 - 2.5	28	Metric	10.90

◆ TAP EXTENSION

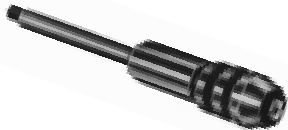

Eliminates the need for extension taps. Knurled grip chucks.

Tap Capacity	Overall Length	Tool No.	Price Each
1/4	7	TEX1	9.90
1/2	10-3/4	TEX2	12.00

◆ TAP GUIDE

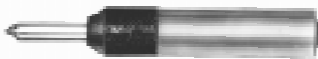

TOOL NO. TG1

- 1/2" diameter hardened shank
- Knurled for easy handling
- 3/16" diameter hardened tension pin
- Adjustable tension spring
- Reversible tension pin for male or female hole centering of tap

PRICE EACH — \$7.95

◆ PILOTED SPINDLE TAP WRENCH

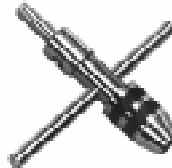

For threading a drilled hole manually at one machine location without moving the workpiece. Hardened and tempered jaws.

Tap Capacity	Tool No.	Price Each
1/16 - 1/4	TWP-1	12.00
1/4 - 1/2	TWP-2	15.00

◆ MINI TAP WRENCH



- Ideal for small tapping applications

Tap Capacity	Range	Tool No.	Price Each
1/4	#0 - 1/4	TWM1	4.80
1/2	5/16 - 1/2	TWM2	5.90

◆ "T" HANDLE TAP WRENCHES

PLAIN TYPE



For hand tapping and for driving screw extractors, heavy knurled cap for better grip.

Tap Capacity		Tool No.	Price Each
Frac. Taps	Machine Screw		
1/16-5/32	0-8	TWH-1	4.95
5/32-1/4	8-12	TWH-2	5.50
1/4-1/2	12	TWH-3	8.75

REVERSIBLE RATCHET TYPE

Tap Capacity		Tool No.	Price Each
Frac. Taps	Machine Screw		
1/16-5/32	0-8	TWR-1	9.78
5/32-1/4	8-12	TWR-2	10.95
1/4-1/2	12	TWR-3	14.34

TAP WRENCH SETS

SET NO. TWHS

3 piece plain type tap Wrench Set
1/16 - 1/2" Capacity
SET PRICE — \$18.50

SET NO. TWRS

3 piece reversible type tap Wrench Set
1/16 - 1/2" Capacity
SET PRICE — \$33.95

◆ EXTRA LONG TAP WRENCH



13" long, hardened and tempered jaws.

Tap Capacity	Tool No.	Price Each
5/32 - 1/4	TWX1	16.70
1/4 - 1/2	TWX4	23.30

◆ MACHINE TAPPING GUIDE

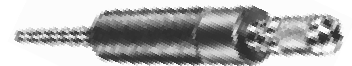

TOOL NO. TG2

- Provides sensitive feel for hand tapping small holes
- Starts every hole straight and prevents tap breakage
- Shank diameter 3/8, handle diameter 1"
- #0 to #12 Tap Capacity

PRICE EACH — \$18.95



SINGLE-END END MILLS

MULTI-FLUTE, REGULAR LENGTH

- ▶ LIST NO. 205 — QUALITY IMPORT
- LIST NO. 205U — MADE IN U.S.A.
- ▶ LIST NO. 240 — QUALITY IMPORT, CENTER CUTTING
- LIST NO. 240U — MADE IN U.S.A., CENTER CUTTING

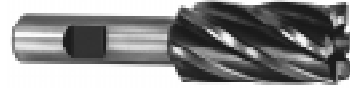

These end mills are designed for general purpose end milling in most types of materials.

Diameter of Cut	Shank Diameter	Length of Cut	Overall Length	No. of Flutes	Price Each			
					Quality Import List No. 205	Made in USA List No. 205U	Import Center Cut List No. 240	USA Center Cut List No. 240U
1/8	3/8	3/8	2-5/16	4	14.20	17.49	16.40	20.50
5/32	3/8	7/16	2-1/4	4	15.13	19.19	—	—
3/16	3/8	1/2	2-3/8	4	14.20	17.49	16.40	20.50
7/32	3/8	5/8	2-3/8	4	15.13	19.19	—	—
1/4	3/8	5/8	2-7/16	4	14.20	17.49	16.40	20.50
9/32	3/8	11/16	2-1/2	4	15.13	17.90	—	—
5/16	3/8	3/4	2-1/2	4	14.20	17.49	16.40	20.50
11/32	3/8	3/4	2-1/2	4	15.13	17.90	—	—
3/8	3/8	3/4	2-1/2	4	14.20	17.49	16.40	20.50
13/32	3/8	1	2-11/16	4	19.00	24.70	—	—
7/16	3/8	1	2-11/16	4	19.00	23.20	23.50	29.00
15/32	3/8	1	2-11/16	4	19.00	23.20	—	—
1/2	3/8	1	2-11/16	4	19.00	22.90	23.50	29.00
1/2	1/2	1-1/4	3-1/4	4	19.40	22.90	23.50	29.00
9/16	1/2	1-3/8	3-3/8	4	24.60	29.90	27.90	41.00
5/8	1/2	1-3/8	3-3/8	4	26.80	32.80	—	—
5/8	5/8	1-5/8	3-3/4	4	29.00	36.70	32.50	39.11
11/16	1/2	1-5/8	3-5/8	4	29.80	35.10	—	—
11/16	5/8	1-5/8	3-3/4	4	30.80	37.85	33.80	41.20
3/4	1/2	1-5/8	3-5/8	4	32.00	37.10	—	—
3/4	5/8	1-5/8	3-3/4	4	32.00	39.25	—	—
3/4	3/4	1-5/8	3-7/8	4	33.20	40.75	38.00	46.78
13/16	1/2	1-7/8	4	4	40.80	—	—	—
13/16	5/8	1-7/8	4	4	40.80	—	—	—
13/16	5/8	1-7/8	4	6	40.80	50.00	—	—
13/16	3/4	1-7/8	4-1/8	4	41.58	47.00	—	—
7/8	1/2	1-5/8	3-5/8	4	42.00	—	—	—
7/8	5/8	1-7/8	4	6	42.00	51.35	—	—
7/8	3/4	1-7/8	4-1/8	4	43.40	51.35	48.00	59.90
7/8	7/8	1-7/8	4-1/8	4	41.40	50.60	—	—
15/16	1/2	1-7/8	4	6	45.96	—	—	—
15/16	5/8	1-7/8	4	6	45.96	—	—	—
15/16	3/4	1-7/8	4-1/8	4	49.58	63.90	—	—
15/16	7/8	1-7/8	4-1/8	4	49.58	57.20	—	—
1	1/2	1-7/8	3-7/8	4	48.00	—	—	—
1	5/8	1-7/8	4	6	48.00	58.60	—	—
1	3/4	1-7/8	4-1/8	4	47.20	57.50	53.00	69.00
1	7/8	1-7/8	4-1/8	4	47.20	57.50	—	—
1	1	2	4-1/2	4	50.00	60.95	55.00	69.00
1-1/16	3/4	2	4-1/4	6	73.00	—	—	—
1-1/8	3/4	1-1/2	3-7/8	6	68.00	85.70	—	—
1-1/8	7/8	2	4-1/4	6	66.00	80.69	—	—
1-1/8	1	2	4-1/2	6	68.00	83.20	—	—
1-3/16	3/4	1-1/2	3-7/8	6	73.00	—	—	—
1-1/4	3/4	1-1/2	3-7/8	6	75.00	88.00	—	—
1-1/4	7/8	2	4-1/4	6	72.00	88.00	—	—
1-1/4	1	2	4-1/2	6	74.40	90.84	—	—
1-1/4	1-1/4	2	4-1/2	4	80.00	94.00	86.25	107.00
1-1/4	1-1/4	2	4-1/2	6	80.00	94.00	—	—
1-5/16	3/4	1-1/2	3-7/8	6	94.00	—	—	—
1-3/8	3/4	1-1/2	3-7/8	6	96.00	108.00	—	—
1-3/8	1	2	4-1/2	6	89.00	110.39	—	—
1-3/8	1-1/4	2	4-1/2	6	89.00	—	—	—
1-7/16	3/4	1-1/2	3-7/8	6	100.00	—	—	—
1-1/2	3/4	1-1/2	3-7/8	6	100.00	121.30	—	—
1-1/2	1	2	4-1/2	6	100.00	116.00	—	—
1-1/2	1-1/4	2	4-1/2	4	100.00	116.00	106.25	132.00
1-1/2	1-1/4	2	4-1/2	6	100.00	116.00	—	—
1-5/8	3/4	1-1/2	3-7/8	6	109.09	126.90	—	—
1-5/8	1-1/4	2	4-1/2	6	109.09	126.90	—	—
1-3/4	3/4	1-1/2	3-7/8	6	118.00	—	—	—
1-3/4	1-1/4	2	4-1/2	4	118.00	137.00	—	—
1-3/4	1-1/4	2	4-1/2	6	118.00	137.00	—	—
1-7/8	3/4	1-1/2	3-7/8	6	127.34	—	—	—
1-7/8	1-1/4	2	4-1/2	4	127.34	—	—	—
1-7/8	1-1/4	2	4-1/2	6	127.34	—	—	—
1-7/8	1-1/4	2	4-1/2	8	127.34	137.00	—	—
2	3/4	1-1/2	3-7/8	6	144.00	—	—	—
2	1-1/4	2	4-1/2	4	144.00	165.90	—	—
2	1-1/4	2	4-1/2	6	144.00	165.90	—	—
2	1-1/4	2	4-1/2	8	144.00	165.90	—	—
2-1/4	1-1/4	2	4-1/2	6	195.00	—	—	—

SETS MULTI-FLUTE REGULAR LENGTH

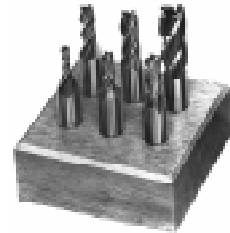

3/8" SHANK
6 Piece Set
Contains 1 piece of each:
1/8, 3/16, 1/4, 5/16, 3/8, 1/2
Supplied in wood block.

SET NO. 205A
QUALITY IMPORT
SET PRICE — \$88.50

SET NO. 205AU
MADE IN U.S.A.
SET PRICE — \$110.00

SET NO. 240A
QUALITY IMPORT
Center cutting
SET PRICE — \$105.00

SET NO. 240AU
MADE IN U.S.A.
Center cutting
SET PRICE — \$131.00

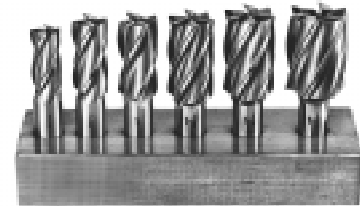

3/4" SHANK
6 Piece Set
Contains 1 piece of each:
3/4, 7/8, 1", 1-1/8, 1-1/4, 1-1/2
Supplied in wood block.

SET NO. 205S
QUALITY IMPORT
SET PRICE — \$363.50

SET NO. 205SU
MADE IN U.S.A.
SET PRICE — \$445.00



MULTI-FLUTE SINGLE-END END MILLS

MEDIUM FLUTE



► LIST NO. 206MF — QUALITY IMPORT

Diameter of Cut	Shank Diameter	Length of Cut	Overall Length	No. of Flutes	Price Each
1	1	3	5-1/2	4	60.00
1-1/4	1-1/4	3	5-1/2	4	95.00
1-1/4	1-1/4	3	5-1/2	6	95.00
1-1/2	1-1/4	3	5-1/2	4	123.00
1-1/2	1-1/4	3	5-1/2	6	123.00
1-3/4	1-1/4	3	5-1/2	6	152.00
2	1-1/4	3	5-1/2	6	194.00
2-1/4	1-1/4	3	5-1/2	6	264.00
2-1/2	1-1/4	3	5-1/2	6	283.00



◆ END MILL DISPENSER CABINETS — All Steel

Description	Case No.	Price Each
Two Flute Single and Double End 1/16 to 1"	CZD10	299.00
Four FLute Single and Double End 1/16 to 1"	CZD11	299.00
Two and Four Flute Single and Double End 1/8 to 1"	CZD12	77.00

LONG FLUTE

► LIST NO. 206 — QUALITY IMPORT
● LIST NO. 206U — MADE IN U.S.A.



Diameter of Cut	Shank Diameter	Length of Cut	Overall Length	No. of Flutes	Price Each	
					List No. 206	List No. 206U
1/4	3/8	1-1/4	3-1/16	4	18.80	22.50
5/16	3/8	1-3/8	3-1/8	4	18.80	22.50
3/8	3/8	1-1/2	3-1/4	4	18.80	22.50
7/16	1/2	1-3/4	3-3/4	4	24.80	31.30
1/2	1/2	2	4	4	24.80	31.30
5/8	5/8	2-1/2	4-5/8	4	34.80	43.50
3/4	1/2	3	5-1/4	4	42.40	—
3/4	3/4	3	5-1/4	4	42.40	50.50
13/16	7/8	3-1/2	5-3/4	4	56.00	—
7/8	3/4	3-1/2	5-3/4	4	53.40	—
7/8	7/8	3-1/2	5-3/4	4	53.40	66.80
1	3/4	4	6-1/2	4	72.00	—
1	1	4	6-1/2	4	70.00	86.80

Diameter of Cut	Shank Diameter	Length of Cut	Overall Length	No. of Flutes	Price Each	
					List No. 206	List No. 206U
1-1/8	1	4	6-1/2	6	92.00	—
1-1/4	3/4	4	6-1/2	6	115.00	—
1-1/4	1	4	6-1/2	6	110.00	—
1-1/4	1-1/4	4	6-1/2	4	110.00	—
1-1/4	1-1/4	4	6-1/2	6	110.00	134.70
1-3/8	1	4	6-1/2	6	129.17	—
1-1/2	1	4	6-1/2	6	135.00	—
1-1/2	1-1/4	4	6-1/2	4	135.00	—
1-1/2	1-1/4	4	6-1/2	6	135.00	171.40
1-1/2	1-1/4	6	8-1/2	6	145.00	—
1-3/4	1-1/4	4	6-1/2	6	170.00	—
2	1-1/4	4	6-1/2	6	208.00	—
2	1-1/4	4	6-1/2	8	208.00	257.00

EXTRA LONG FLUTE

► LIST NO. 207 — QUALITY IMPORT
● LIST NO. 207U — MADE IN U.S.A.



Diameter of Cut	Shank Diameter	Length of Cut	Overall Length	No. of Flutes	Price Each	
					List No. 207	List No. 207U
1/4	3/8	1-3/4	3-9/16	4	21.60	25.50
5/16	3/8	2	3-3/4	4	22.60	26.90
3/8	3/8	2-1/2	4-1/4	4	23.60	27.48
1/2	1/2	3	5	4	29.60	35.25
5/8	1/2	4	6-1/8	4	42.00	—
5/8	5/8	4	6-1/8	4	42.00	50.90
3/4	1/2	4	6-1/4	4	51.00	—

Diameter of Cut	Shank Diameter	Length of Cut	Overall Length	No. of Flutes	Price Each	
					List No. 207	List No. 207U
3/4	3/4	4	6-1/4	4	50.00	59.80
7/8	7/8	5	7-1/4	4	65.00	—
1	1	6	8-1/2	4	86.00	104.20
1-1/4	1-1/4	6	8-1/2	4	130.00	—
1-1/4	1-1/4	6	8-1/2	6	130.00	156.95
1-1/2	1-1/4	8	10-1/2	6	206.00	—

HEAVY DUTY WITH COMBINATION SHANKS

● LIST NO. 277 — QUALITY IMPORT



Diameter of Cut	Shank Diameter	Length of Cut	Overall Length	No. of Flutes	Price Each
2	1-1/2	4	6-7/8	3	268.00
2	2	2	5-3/4	6	207.00
2	2	2	5-3/4	4	199.00
2	2	3	6-3/4	2	198.00
2	2	3	6-3/4	3	268.00
2	2	4	7-3/4	2	237.00
2	2	4	7-3/4	3	268.00
2	2	4	7-3/4	4	230.00
2	2	4	7-3/4	6	230.00
2	2	4	7-3/4	6 Ball	330.00
2	2	5	8-3/4	2	256.00
2	2	5	8-3/4	2 Ball	365.50
2	2	6	9-3/4	2	278.00
2	2	6	9-3/4	3	280.00
2	2	6	9-3/4	4	280.00
2	2	6	9-3/4	6 Cobalt	540.00
2	2	6	9-3/4	6 Ball	406.00
2	2	6	9-3/4	8	280.00
2	2	8	11-3/4	6	334.00

Diameter of Cut	Shank Diameter	Length of Cut	Overall Length	No. of Flutes	Price Each
2	2	8	11-3/4	6 Ball	478.00
2	2	10	13-3/4	6	388.00
2-1/2	2	4	7-3/4	4	320.00
2-1/2	2	6	9-3/4	6	320.00
2-1/2	2	4	7-3/4	2	516.00
2-1/2	2	6	9-3/4	6	400.00
2-1/2	2	8	11-5/8	4	468.00
2-1/2	2	8	11-5/8	6	468.00
2-1/2	2-1/2	4	8	3	327.00
2-1/2	2-1/2	4	8	4	331.00
2-1/2	2-1/2	4	8	6	331.00
2-1/2	2-1/2	5	9	4	413.00
2-1/2	2-1/2	5	9	6	413.00
2-1/2	2-1/2	6	10	2	500.00
2-1/2	2-1/2	6	10	3	525.00
2-1/2	2-1/2	6	10	4	442.00
3	2-1/2	4	7-3/4	8	418.00
3	2-1/2	5	8-3/4	6	458.00
3	2-1/2	5	8-3/4	8	458.00



SINGLE-END END MILLS

These end mills are designed for plunge cutting to be used in slotting operations for all types of materials.

TWO FLUTE, REGULAR LENGTH

- ▶ LIST NO. 231 — QUALITY IMPORT
- LIST NO. 231U — MADE IN U.S.A.



Diameter of Cut	Shank Diameter	Length of Cut	Overall Length	Price Each	
				Quality Import List No. 231	Made in USA List No. 231U
1/8	3/8	3/8	2-5/16	13.40	15.95
5/32	3/8	3/8	2-1/4	13.40	18.25
3/16	3/8	7/16	2-5/16	13.40	15.95
7/32	3/8	1/2	2-1/4	13.40	18.25
1/4	3/8	1/2	2-5/16	13.40	15.95
9/32	3/8	9/16	2-1/4	13.40	18.25
5/16	3/8	9/16	2-5/16	13.40	15.95
11/32	3/8	9/16	2-1/4	13.40	18.25
3/8	3/8	9/16	2-5/16	13.40	15.95
13/32	3/8	13/16	2-1/2	19.80	23.70
7/16	3/8	13/16	2-1/2	19.80	23.70
15/32	3/8	13/16	2-1/2	19.80	23.70
1/2	3/8	13/16	2-1/2	19.80	23.70
1/2	1/2	1	3	21.00	23.75
9/16	1/2	1-1/8	3-1/8	24.48	28.12
19/32	1/2	1-1/8	3-1/8	28.50	—
5/8	1/2	1-1/8	3-1/8	27.44	32.70
5/8	5/8	1-5/16	3-7/16	27.80	32.00
11/16	1/2	1-5/16	3-5/16	29.60	34.95
11/16	5/8	1-5/16	3-7/16	29.60	34.95
3/4	1/2	1-5/16	3-5/16	31.60	37.50
3/4	5/8	1-5/16	3-7/16	31.60	37.50
3/4	3/4	1-5/16	3-9/16	31.60	37.50
13/16	1/2	1-1/2	3-1/2	37.20	—
13/16	5/8	1-1/2	3-5/8	37.20	46.90
13/16	3/4	1-1/2	3-3/4	37.20	46.90
7/8	1/2	1-1/2	3-1/2	37.20	—
7/8	5/8	1-1/2	3-5/8	37.20	46.30
7/8	3/4	1-1/2	3-3/4	37.20	46.30
7/8	7/8	1-1/2	3-3/4	39.00	46.30
15/16	5/8	1-1/2	3-3/8	44.20	51.98
15/16	3/4	1-1/2	3-3/4	44.20	52.38
15/16	7/8	1-1/2	3-3/4	44.20	51.98
1	1/2	1-1/2	3-5/8	44.20	—
1	5/8	1-1/2	3-5/8	44.20	51.80
1	3/4	1-1/2	3-3/4	44.20	51.80
1	7/8	1-1/2	3-3/4	44.20	55.20
1	1	1-5/8	4-1/2	47.20	62.90
1-1/16	3/4	1-1/2	3-7/8	63.40	—
1-1/8	3/4	1-1/2	3-7/8	63.40	95.00
1-1/8	7/8	1-5/8	4-5/16	68.80	85.00
1-1/8	1	1-5/8	4-1/2	68.80	85.00
1-3/16	3/4	1-1/2	3-7/8	80.20	—
1-1/4	3/4	1-1/2	3-7/8	80.20	104.00
1-1/4	7/8	1-5/8	4-5/16	67.80	88.50
1-1/4	1	1-5/8	4-1/2	76.80	96.00
1-1/4	1-1/4	1-5/8	4-1/2	82.20	96.00
1-5/16	3/4	1-1/2	3-7/8	95.40	—
1-3/8	3/4	1-1/2	3-7/8	95.40	113.80
1-3/8	1	1-5/8	4-1/2	91.20	106.90
1-3/8	1-1/4	1-5/8	4-1/2	91.20	—
1-7/16	3/4	1-1/2	3-7/8	95.60	—
1-1/2	3/4	1-1/2	3-7/8	95.60	124.50
1-1/2	1	1-5/8	4-1/2	100.00	117.10
1-1/2	1-1/4	1-5/8	4-1/2	100.00	117.10
1-5/8	3/4	1-1/2	3-7/8	110.28	—
1-5/8	1-1/4	1-5/8	4-1/2	109.55	125.71
1-3/4	3/4	1-1/2	3-7/8	130.00	—
1-3/4	1-1/4	1-5/8	4-1/2	120.00	139.95
1-7/8	3/4	1-1/2	3-7/8	132.00	—
1-7/8	1-1/4	1-5/8	4-1/2	129.36	151.39
2	3/4	1-1/2	3-7/8	148.50	—
2	1-1/4	1-5/8	4-1/2	142.00	162.00
2	1-1/4	2-1/2	5	152.15	—

TWO FLUTE, LONG LENGTH

- LIST NO. 233 — QUALITY IMPORT



Diameter of Cut	Shank Diameter	Length of Cut	Overall Length	Price Each
1/4	3/8	1-1/2	3-1/4	20.73
5/16	3/8	1-1/2	3-1/4	20.73
3/8	3/8	1-1/2	3-1/4	20.80
1/2	1/2	2	4	26.40
1/2	1/2	3	5-1/16	35.28
5/8	1/2	2-3/8	4-1/2	33.00
5/8	5/8	2	4-1/8	30.80
5/8	5/8	2-1/2	4-5/8	38.69
5/8	5/8	3	5-1/8	46.57
3/4	1/2	2-3/4	5-1/4	39.79
3/4	3/4	2-1/4	4-1/2	37.20
7/8	7/8	2-1/2	4-3/4	45.63
7/8	7/8	3	5-1/4	47.09
1	1	3	5-1/2	61.20
1-1/8	1	3	5-1/2	81.79
1-1/4	1	3	5-1/2	95.60
1-1/4	1-1/4	3	5-1/2	95.60
1-3/8	1	3	5-1/2	104.11
1-1/2	1-1/4	3	5-1/2	115.00
1-5/8	1-1/4	3	5-1/2	131.69
1-3/4	1-1/4	3	5-1/2	144.00
1-7/8	1-1/4	3	5-1/2	163.91
2	1-1/4	3	5-1/2	173.00
2	2	4-1/2	7-3/4	230.00

Titanium Nitride coating available. Please inquire.

● TWO FLUTE, EXTENSION TYPE

- LIST NO. 234 — QUALITY IMPORT

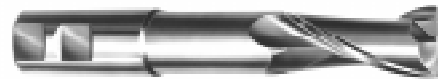

Diameter of Cut	Shank Diameter	Length of Cut	Overall Length	Price Each
1/8	3/8	3/8	2-3/8	20.20
3/16	3/8	1/2	2-11/16	20.20
1/4	3/8	5/8	3-1/16	20.20
5/16	3/8	3/4	3-5/16	20.20
3/8	3/8	3/4	3-5/16	20.20
1/2	1/2	1	4	24.20
5/8	1/2	1-3/8	4-1/2	35.60
5/8	5/8	1-3/8	4-5/8	35.60
3/4	1/2	1-5/8	5-1/4	45.20
3/4	3/4	1-5/8	5-3/8	45.20
7/8	7/8	2	6	58.60
1	1	2-1/2	7-1/4	80.00
1-1/4	1-1/4	3	7-1/4	110.00

Titanium Nitride coating available. Please inquire.

SETS

TWO FLUTE, REGULAR LENGTH

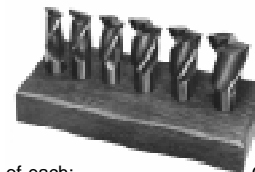

3/8" SHANK

6 Piece Set
Contains 1 piece of each:
1/8, 3/16, 1/4, 5/16, 3/8, 1/2
Supplied in wood block.

3/4" SHANK

6 Piece Set
Contains 1 piece of each:
3/4, 7/8, 1, 1-1/8, 1-1/4, 1-1/2
Supplied in wood block.

SET NO. 231A
QUALITY IMPORT
SET PRICE — \$89.00

SET NO. 231S
QUALITY IMPORT
SET PRICE — \$349.00

SET NO. 231AU
MADE IN U.S.A.
SET PRICE — \$103.00

SET NO. 231SU
MADE IN U.S.A.
SET PRICE — \$459.00

METRIC END MILLS

FOUR FLUTE, SINGLE END

▶ LIST NO. 205M



TWO FLUTE, SINGLE END

▶ LIST NO. 231M

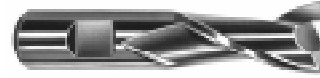

These end mills are designed for general purpose end milling in all types of materials.

Diameter of Cut mm	Shank Diameter Inches	Length of Cut Inches	Overall Length Inches	Price Each	Shank Diameter Inches	Length of Cut Inches	Overall Length Inches	Price Each
				4 Flute List No. 205M				2 Flute List No. 231M
3	3/8	3/8	2-5/16	17.09	3/8	3/8	2-5/16	17.39
4	3/8	1/2	2-3/8	17.09	3/8	7/16	2-5/16	17.39
4.5	3/8	1/2	2-3/8	17.09	—	—	—	—
5	3/8	9/16	2-1/2	17.09	3/8	1/2	2-5/16	17.39
6	3/8	5/8	2-1/2	17.09	3/8	1/2	2-5/16	17.39
7	3/8	3/4	2-1/2	17.09	3/8	9/16	2-5/16	17.39
8	3/8	3/4	2-1/2	17.09	3/8	9/16	2-5/16	17.39
9	3/8	3/4	2-1/2	17.09	3/8	9/16	2-5/16	17.39
10	3/8	1	2-11/16	21.09	3/8	13/16	2-1/2	21.09
11	3/8	1	2-11/16	22.89	3/8	13/16	2-1/2	25.38
12	3/8	1	2-11/16	23.39	3/8	13/16	2-1/2	26.69
12	—	—	—	—	1/2	1-1/8	3-1/8	26.69
13	1/2	1-1/4	3-1/4	26.69	1/2	1-1/8	3-1/8	33.09
14	1/2	1-1/4	3-1/4	26.69	1/2	1-1/8	3-1/8	33.09
15	1/2	1-3/8	3-3/8	27.89	1/2	1-1/8	3-1/8	33.09
16	—	—	—	—	1/2	1-1/8	3-1/8	35.49
16	5/8	1-5/8	3-3/4	32.08	5/8	1-5/16	3-7/16	35.49
18	5/8	1-5/8	3-3/4	35.99	1/2	1-5/16	3-7/16	39.49
18	3/4	1-5/8	3-3/4	35.99	5/8	1-5/16	3-7/16	39.49
18	1/2	1-1/2	3-5/8	35.99	—	—	—	—
19	3/4	1-5/8	3-3/4	38.09	3/4	1-5/16	3-7/16	40.69
20	5/8	1-7/8	4-1/8	38.09	5/8	1-1/2	3-3/4	47.29
20	3/4	1-7/8	4-1/8	38.09	3/4	1-1/2	3-3/4	47.29
22	3/4	1-7/8	4-1/8	48.59	3/4	1-1/2	3-3/4	50.49
22	7/8	1-7/8	4-1/8	48.59	7/8	1-1/2	3-3/4	50.49
24	3/4	2	4-1/2	56.89	1/2	2	4-1/2	60.09
24	7/8	2	4-1/2	56.89	3/4	2	4-1/2	60.09
25	3/4	1-7/8	4-1/2	59.90	3/4	2	4-1/2	60.09
25	1	2	4-1/2	59.90	1	2	4-1/2	60.09
26	—	—	—	—	3/4	2	4-1/2	99.98
26	1	2	4-1/2	98.00	1	2	4-1/2	99.98
30	—	—	—	—	1	2	4-1/2	99.98
32	1	2	4-1/2	109.99	1	2	4-1/2	113.99
36	1	2	4-1/2	109.99	1	2	4-1/2	113.99

SETS

SET NO. 205MA

6 Piece Set — 4 Flute
3/8" Shanks
Contains 1 piece of each:
3mm, 5mm, 7mm, 8mm, 10mm
and 12mm
Supplied in wood block.
SET PRICE — \$113.00

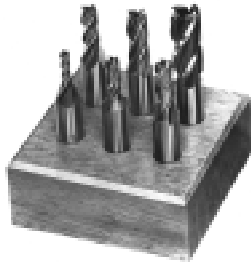

SET NO. 231MA

6 Piece Set — 2 Flute
3/8" Shanks
Contains 1 piece of each:
3mm, 5mm, 7mm, 8mm, 10mm
and 12mm
Supplied in wood block.
SET PRICE — \$117.00

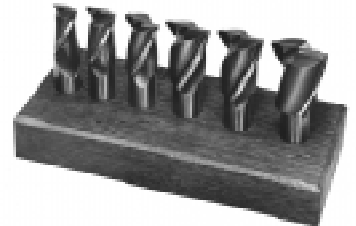

SET NO. 205MB

4 Piece Set — 4 Flute
Contains 1 piece of each:
14mm with 1/2 shank, 16mm with 5/8 shank,
20mm with 3/4 shank, 24mm with 3/4 shank
Supplied in wood block.
SET PRICE — \$154.00

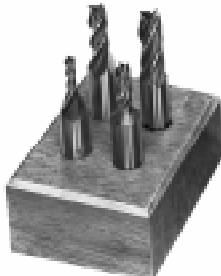

SET NO. 231MB

4 Piece Set — 2 Flute
Contains 1 piece of each:
14mm with 1/2 shank, 16mm with 5/8 shank,
20mm with 3/4 shank, 24mm with 3/4 shank
Supplied in wood block.
SET PRICE — \$176.00



DOUBLE-END END MILLS

TWO FLUTE



- ▶ LIST NO. 261 — QUALITY IMPORT
- LIST NO. 261U — MADE IN U.S.A.

Dia. of Cut	Shank Dia.	Length of Cut	Overall Length	Price Each	
				List No. 261	List No. 261U
1/8	3/8	3/8	3-1/16	19.80	24.70
5/32	3/8	7/16	3-1/8	20.20	24.70
11/64	3/8	7/16	3-1/8	20.39	—
3/16	3/8	7/16	3-1/8	19.40	24.70
13/64	3/8	1/2	3-1/8	20.81	—
7/32	3/8	1/2	3-1/8	20.20	24.70
1/4	3/8	1/2	3-1/8	19.40	24.70
9/32	3/8	9/16	3-1/8	20.20	24.70
5/16	3/8	9/16	3-1/8	19.40	24.70
21/64	3/8	9/16	3-1/8	20.81	—
11/32	3/8	9/16	3-1/8	20.20	24.70
3/8	3/8	9/16	3-1/8	19.40	24.70
13/32	1/2	13/16	3-3/4	30.60	37.25
7/16	1/2	13/16	3-3/4	28.60	35.70
15/32	1/2	13/16	3-3/4	30.60	37.25
1/2	1/2	13/16	3-3/4	30.60	37.25
9/16	5/8	1-1/8	4-1/2	40.40	49.30
5/8	5/8	1-1/8	4-1/2	40.40	49.30
11/16	3/4	1-5/16	5	50.00	62.00
23/32	3/4	1-5/16	5	53.00	—
3/4	3/4	1-5/16	5	50.00	62.00
25/32	7/8	1-9/16	5-1/2	56.65	—
13/16	7/8	1-9/16	5-1/2	63.60	78.00
27/32	7/8	1-9/16	5-1/2	65.92	—
7/8	7/8	1-9/16	5-1/2	64.00	78.00
29/32	1	1-5/8	5-7/8	80.34	—
15/16	1	1-5/8	5-7/8	78.00	96.00
31/32	1	1-5/8	5-7/8	80.34	—
1	1	1-5/8	5-7/8	78.00	96.00

FOUR FLUTE

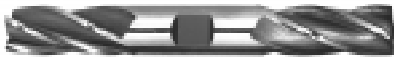

- ▶ LIST NO. 241 — QUALITY IMPORT
- LIST NO. 241U — MADE IN U.S.A.
- ▶ LIST NO. 242 — QUALITY IMPORT CENTER CUT
- LIST NO. 242U — MADE IN U.S.A. CENTER CUT

Dia. of Cut	Shank Dia.	Length of Cut	Overall Length	Price Each			
				List No. 241	List No. 241U	List No. 242	List No. 242U
1/8	3/8	3/8	3-1/16	19.80	22.60	24.16	29.90
5/32	3/8	7/16	3-1/8	20.60	23.50	26.57	31.00
3/16	3/8	1/2	3-1/4	19.80	22.60	24.16	29.90
7/32	3/8	9/16	3-1/4	20.60	23.50	26.57	31.00
15/64	3/8	5/8	3-3/8	20.39	—	—	—
1/4	3/8	5/8	3-3/8	19.80	22.60	24.16	29.90
9/32	3/8	11/16	3-3/8	20.60	23.50	26.57	31.00
19/64	3/8	3/4	3-1/2	20.39	—	—	—
5/16	3/8	3/4	3-1/2	19.80	22.60	24.16	29.90
21/64	3/8	3/4	3-1/2	20.81	—	—	—
11/32	3/8	3/4	3-1/2	20.60	23.50	26.57	31.00
3/8	3/8	3/4	3-1/2	19.80	22.60	24.16	29.90
13/32	1/2	1	4-1/8	27.80	35.25	35.03	31.00
7/16	1/2	1	4-1/8	29.40	33.56	36.46	46.00
15/32	1/2	1	4-1/8	30.60	34.95	36.72	46.00
1/2	1/2	1	4-1/8	29.80	34.00	34.57	44.95
17/32	5/8	1-3/8	5	41.61	—	—	—
9/16	5/8	1-3/8	5	40.40	46.99	47.27	62.60
5/8	5/8	1-3/8	5	39.80	46.99	46.57	62.60
21/32	3/4	1-5/8	5-5/8	52.53	—	—	—
11/16	3/4	1-5/8	5-5/8	51.00	59.35	59.16	78.90
23/32	3/4	1-5/8	5-5/8	53.56	—	—	—
3/4	3/4	1-5/8	5-5/8	52.00	60.48	60.84	78.90
13/16	7/8	1-7/8	6-1/8	65.00	74.50	76.70	100.90
27/32	7/8	1-7/8	6-1/8	65.92	—	—	—
7/8	7/8	1-7/8	6-1/8	64.00	74.45	75.52	100.90
29/32	1	1-7/8	6-3/8	80.34	—	—	—
15/16	1	1-7/8	6-3/8	69.00	85.70	82.80	122.80
1	1	1-7/8	6-3/8	78.00	90.75	93.60	122.80

SETS

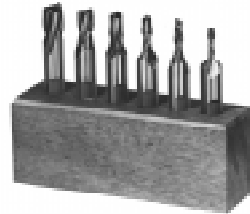

SET NO. 261A
QUALITY IMPORT
TWO FLUTE — 3/8" SHANK
6 Piece Set
Contains 1 piece of each:
1/8, 5/32, 3/16, 1/4, 5/16, 3/8
Supplied in wood block.
SET PRICE — \$117.00

SET NO. 261AU
MADE IN U.S.A.
TWO FLUTE — 3/8" SHANK
6 Piece Set
Contains 1 piece of each:
1/8, 5/32, 3/16, 1/4, 5/16, 3/8
Supplied in wood block.
SET PRICE — \$148.00

SET NO. 261B
QUALITY IMPORT
TWO FLUTE
6 Piece Set
Contains 1 piece of each:
1/8, 3/16, 1/4, 5/16, 3/8, 1/2x1/2
Supplied in wood block.
SET PRICE — \$128.00

SETS

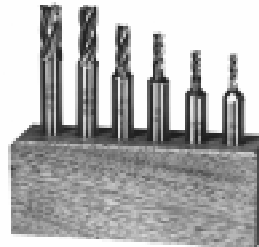

SET NO. 241A
QUALITY IMPORT
FOUR FLUTE — 3/8" SHANK
6 Piece Set
Contains 1 piece of each:
1/8, 5/32, 3/16, 1/4, 5/16, 3/8
Supplied in wood block.
SET PRICE — \$119.00

SET NO. 241B
QUALITY IMPORT
FOUR FLUTE
6 Piece Set
Contains 1 piece of each:
1/8, 3/16, 1/4, 5/16, 3/8, 1/2x1/2
Supplied in wood block.
SET PRICE — \$128.00

SET NO. 242A
QUALITY IMPORT
FOUR FLUTE — 3/8" SHANK
CENTER CUTTING
6 Piece Set
Contains 1 piece of each:
1/8, 5/32, 3/16, 1/4, 5/16, 3/8
Supplied in wood block.
SET PRICE — \$147.00

SET NO. 242AU
MADE IN U.S.A.
FOUR FLUTE — 3/8" SHANK
CENTER CUTTING
6 Piece Set
Contains 1 piece of each:
1/8, 5/32, 3/16, 1/4, 5/16, 3/8
Supplied in wood block.
SET PRICE — \$180.00

COATED SINGLE-END END MILLS

MULTI-FLUTE

TiN Coating: *Titanium Nitride Coating* is the ideal coating for a wide range of applications, materials and cutting conditions where tool life and elevated feeds and speeds are the operating objectives. The high lubricity of TiN Coating facilitates chip flow, prevents build up, reduces cutting forces and regulates temperature. TiN Coating reduces wear and improves chip formation to extend tool life. In addition, the high hardness and low coefficient of friction of TiN reduces erosion, abrasion and corrosion.

TiAlN Coating: *Titanium Aluminum Nitride Coating* is ideal for high temperature cutting operations in many materials. When TiAlN is exposed to high cutting temperature it forms a hard aluminum oxide layer with low thermal conductivity and high chemical stability. As cutting temperatures increase, TiAlN insulates the tool and ejects heat into the chips. As a result, production levels increase with higher speeds, reduced down time and longer tool life.



- LIST NO. 205T — QUALITY IMPORT TiN COATED
- LIST NO. 205TU — MADE IN U.S.A. TiN COATED
- LIST NO. 205TAU — MADE IN U.S.A. TiAlN COATED

SETS

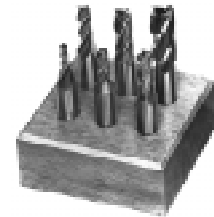

3/8" SHANK — MULTI-FLUTE

6 Piece Set
Contains 1 piece of each:
1/8, 3/16, 1/4, 5/16, 3/8, 1/2
Supplied in wood block.

SET NO. 205AT
Import TiN Coated
SET PRICE — \$125.00

SET NO. 205ATU
USA TiN Coated
SET PRICE — \$172.00

SET NO. 205ATAU
USA TiAlN Coated
SET PRICE — \$215.00



3/4" SHANK — MULTI-FLUTE

6 Piece Set
Contains 1 piece of each:
3/4, 7/8, 1", 1-1/8, 1-1/4, 1-1/2
Supplied in wood block.

SET NO. 205ST
Import TiN Coated
SET PRICE — \$522.30

SET NO. 205STU
USA TiN Coated
SET PRICE — \$751.00

SET NO. 205STAU
USA TiAlN Coated
SET PRICE — \$841.00

Diameter of Cut	Shank Diameter	Length of Cut	Overall Length	No. of Flutes	Price Each		
					List No. 205T	List No. 205TU	List No. 205TAU
1/8	3/8	3/8	2-5/16	4	19.96	27.00	34.27
5/32	3/8	7/16	2-1/4	4	20.89	27.00	35.71
3/16	3/8	1/2	2-3/8	4	19.96	27.00	34.27
7/32	3/8	5/8	2-3/8	4	20.89	27.00	35.71
1/4	3/8	5/8	2-7/16	4	19.96	27.00	34.27
9/32	3/8	11/16	2-1/2	4	20.89	27.00	35.71
5/16	3/8	3/4	2-1/2	4	19.96	27.00	34.27
11/32	3/8	3/4	2-1/2	4	20.89	27.00	35.71
3/8	3/8	3/4	2-1/2	4	19.96	27.00	34.27
13/32	3/8	1	2-11/16	4	25.72	37.00	43.20
7/16	3/8	1	2-11/16	4	25.72	37.00	43.20
15/32	3/8	1	2-11/16	4	25.72	37.00	43.20
1/2	3/8	1	2-11/16	4	25.72	37.00	43.20
1/2	1/2	1-1/4	3-1/4	4	28.52	38.00	47.54
9/16	1/2	1-3/8	3-3/8	4	34.80	49.95	57.27
5/8	1/2	1-3/8	3-3/8	4	37.00	54.00	60.68
5/8	5/8	1-5/8	3-3/4	4	39.20	58.00	64.09
11/16	1/2	1-5/8	3-5/8	4	42.04	61.50	68.49
11/16	5/8	1-5/8	3-3/4	4	43.04	65.00	70.04
3/4	1/2	1-5/8	3-5/8	4	44.24	66.80	71.90
3/4	5/8	1-5/8	3-3/4	4	44.24	66.80	71.90
3/4	3/4	1-5/8	3-7/8	4	45.44	68.60	73.76
13/16	1/2	1-7/8	4	4	58.45	96.00	93.93
13/16	5/8	1-7/8	4	6	58.45	96.00	93.93
13/16	3/4	1-7/8	4-1/8	4	61.87	96.00	99.23
7/8	1/2	1-5/8	3-5/8	4	59.65	98.50	95.79
7/8	5/8	1-7/8	4	6	59.65	98.50	95.79
7/8	3/4	1-7/8	4-1/8	4	63.69	98.50	102.05
7/8	7/8	1-7/8	4-1/8	4	61.69	98.50	98.95
15/16	5/8	1-7/8	4	6	63.61	82.50	101.93
15/16	3/4	1-7/8	4-1/8	4	69.87	82.50	111.63
15/16	7/8	1-7/8	4-1/8	4	69.87	82.50	111.63
1	1/2	1-7/8	3-7/8	4	65.65	107.00	105.09
1	5/8	1-7/8	4	6	65.65	107.00	105.09
1	3/4	1-7/8	4-1/8	4	67.49	107.00	107.94
1	7/8	1-7/8	4-1/8	4	67.49	107.00	107.94
1	1	2	4-1/2	4	70.29	107.00	112.28
1-1/16	3/4	2	4-1/4	6	100.36	130.00	158.89
1-1/8	3/4	1-1/2	3-7/8	6	95.36	144.00	151.14
1-1/8	1	2	4-1/2	6	95.36	144.00	151.14
1-1/4	3/4	1-1/2	3-7/8	6	102.36	144.00	161.99
1-1/4	7/8	2	4-1/4	6	99.36	144.00	157.34
1-1/4	1	2	4-1/2	6	101.76	148.00	161.06
1-1/4	1-1/4	2	4-1/2	4	107.36	156.00	169.74
1-1/4	1-1/4	2	4-1/2	6	107.36	156.00	169.74
1-3/8	3/4	1-1/2	3-7/8	6	138.72	170.00	218.35
1-3/8	1	2	4-1/2	6	131.72	170.00	207.50
1-7/16	3/4	1-1/2	3-7/8	6	142.72	189.00	244.55
1-1/2	3/4	1-1/2	3-7/8	6	142.72	189.00	244.55
1-1/2	1	2	4-1/2	6	142.72	189.00	244.55
1-1/2	1-1/4	2	4-1/2	4	142.72	189.00	244.55
1-1/2	1-1/4	2	4-1/2	6	142.72	189.00	244.55

Sizes larger than 1-1/2 are available in both coatings upon request.

COATED SINGLE-END END MILLS

TWO FLUTE

TiN Coating: *Titanium Nitride Coating* is the ideal coating for a wide range of applications, materials and cutting conditions where tool life and elevated feeds and speeds are the operating objectives. The high lubricity of TiN Coating facilitates chip flow, prevents build up, reduces cutting forces and regulates temperature. TiN Coating reduces wear and improves chip formation to extend tool life. In addition, the high hardness and low coefficient of friction of TiN reduces erosion, abrasion and corrosion.

TiAlN Coating: *Titanium Aluminum Nitride Coating* is ideal for high temperature cutting operations in many materials. When TiAlN is exposed to high cutting temperature it forms a hard aluminum oxide layer with low thermal conductivity and high chemical stability. As cutting temperatures increase, TiAlN insulates the tool and ejects heat into the chips. As a result, production levels increase with higher speeds, reduced down time and longer tool life.



- LIST NO. 231T — QUALITY IMPORT TiN COATED
- LIST NO. 231TU — MADE IN U.S.A. TiN COATED
- LIST NO. 231TAU — MADE IN U.S.A. TiAlN COATED

SETS



3/8" SHANK — TWO FLUTE

6 Piece Set
Contains 1 piece of each:
1/8, 3/16, 1/4, 5/16, 3/8, 1/2
Supplied in wood block.

SET NO. 231AT
Import TiN Coated
SET PRICE — \$125.00

SET NO. 231ATU
USA TiN Coated
SET PRICE — \$184.00

SET NO. 231ATAU
USA TiAlN Coated
SET PRICE — \$209.00



3/4" SHANK — TWO FLUTE

6 Piece Set
Contains 1 piece of each:
3/4, 7/8, 1", 1-1/8, 1-1/4, 1-1/2
Supplied in wood block.

SET NO. 231ST
Import TiN Coated
SET PRICE — \$475.00

SET NO. 231STU
USA TiN Coated
SET PRICE — \$665.00

SET NO. 231STAU
USA TiAlN Coated
SET PRICE — \$761.00

Diameter of Cut	Shank Diameter	Length of Cut	Overall Length	Price Each		
				List No. 231T	List No. 231TU	List No. 231TAU
1/8	3/8	3/8	2-5/16	19.16	27.00	32.88
5/32	3/8	3/8	2-1/4	19.16	27.00	32.88
3/16	3/8	7/16	2-5/16	19.16	29.00	32.88
7/32	3/8	1/2	2-1/4	19.16	29.00	32.88
1/4	3/8	1/2	2-5/16	19.16	29.00	32.88
9/32	3/8	9/16	2-1/4	19.16	29.00	32.88
5/16	3/8	9/16	2-5/16	19.16	29.00	32.88
11/32	3/8	9/16	2-1/4	19.16	29.00	32.88
3/8	3/8	9/16	2-5/16	19.16	29.00	32.88
13/32	3/8	13/16	2-1/2	25.56	38.70	42.80
7/16	3/8	13/16	2-1/2	25.56	38.70	42.80
15/32	3/8	13/16	2-1/2	25.56	41.50	42.80
1/2	3/8	13/16	2-1/2	26.52	41.50	44.28
1/2	1/2	1	3	27.72	41.50	46.14
9/16	1/2	1-1/8	3-1/8	34.68	50.50	56.93
5/8	1/2	1-1/8	3-1/8	37.64	54.60	61.52
5/8	5/8	1-5/16	3-7/16	38.00	57.30	62.08
11/16	1/2	1-5/16	3-5/16	41.84	59.90	68.03
11/16	5/8	1-5/16	3-7/16	41.84	59.90	68.03
3/4	1/2	1-5/16	3-5/16	43.84	60.30	71.13
3/4	5/8	1-5/16	3-7/16	43.84	62.40	71.13
3/4	3/4	1-5/16	3-9/16	43.84	65.90	71.13
13/16	1/2	1-1/2	3-1/2	43.84	70.90	71.13
13/16	5/8	1-1/2	3-5/8	54.84	70.90	88.18
13/16	3/4	1-1/2	3-3/4	54.84	70.90	88.18
7/8	1/2	1-1/2	3-1/2	54.84	70.90	88.18
7/8	5/8	1-1/2	3-5/8	54.84	70.90	88.18
7/8	3/4	1-1/2	3-3/4	54.84	74.00	88.18
7/8	7/8	1-1/2	3-3/4	56.64	76.90	90.97
15/16	5/8	1-1/2	3-3/4	61.84	82.50	99.03
15/16	3/4	1-1/2	3-3/4	61.84	82.50	99.03
15/16	7/8	1-1/2	3-3/4	61.84	82.50	99.03
1	1/2	1-1/2	3-5/8	61.84	84.00	99.03
1	5/8	1-1/2	3-5/8	61.84	84.00	99.03
1	3/4	1-1/2	3-3/4	61.84	84.00	99.03
1	7/8	1-1/2	3-3/4	61.84	93.50	99.03
1	1	1-5/8	4-1/8	67.48	103.00	107.77
1-1/16	3/4	1-5/8	3-7/8	85.60	115.00	135.86
1-1/8	3/4	1-5/8	3-7/8	85.60	119.80	135.86
1-1/8	7/8	1-5/8	3-7/8	91.00	128.90	144.23
1-1/8	1	1-5/8	4-1/8	96.16	134.60	152.23
1-1/4	3/4	1-5/8	3-7/8	102.40	149.00	161.90
1-1/4	1	1-5/8	4-1/8	104.16	144.00	164.63
1-3/8	3/4	1-5/8	3-7/8	130.08	160.00	204.80
1-3/8	1	1-5/8	4-1/8	133.92	172.00	210.75
1-1/2	3/4	1-5/8	3-7/8	130.28	181.00	205.11
1-1/2	1	1-5/8	4-1/8	142.72	211.00	224.39
1-1/2	1-1/4	1-5/8	4-1/8	142.72	211.00	224.39

Sizes larger than 1-1/2 are available in both coatings upon request.

COATED DOUBLE-END END MILLS

REGULAR LENGTH — TWO FLUTE

- LIST NO. 261T — QUALITY IMPORT TIN COATED
- LIST NO. 261TU — MADE IN U.S.A. TIN COATED
- LIST NO. 261TAU — MADE IN U.S.A. TIAN COATED



Dia. of Cut	Shank Dia.	Length of Cut	Overall Length	Price Each		
				List No. 261T	List No. 261TU	List No. 261TAU
1/8	3/8	3/8	3-1/16	33.48	41.50	56.54
5/32	3/8	7/16	3-1/8	33.88	41.50	57.16
3/16	3/8	7/16	3-1/8	33.08	41.50	55.92
7/32	3/8	1/2	3-1/8	33.88	42.50	57.16
1/4	3/8	1/2	3-1/8	33.08	41.50	55.92
9/32	3/8	9/16	3-1/8	33.88	42.50	57.16
5/16	3/8	9/16	3-1/8	33.08	41.50	55.92
11/32	3/8	9/16	3-1/8	33.88	42.50	57.16
3/8	3/8	9/16	3-1/8	33.08	41.50	55.92
13/32	1/2	13/16	3-3/4	50.17	65.00	82.41
7/16	1/2	13/16	3-3/4	48.17	63.30	79.31
15/32	1/2	13/16	3-3/4	50.17	66.80	82.41
1/2	1/2	13/16	3-3/4	50.17	62.50	82.41
9/16	5/8	1-1/8	4-1/2	63.33	89.90	102.81
5/8	5/8	1-1/8	4-1/2	63.33	84.10	102.81
11/16	3/4	1-5/16	5	77.01	124.02	124.02
3/4	3/4	1-5/16	5	77.01	109.00	124.02
13/16	7/8	1-9/16	5-1/2	94.08	129.00	150.47
7/8	7/8	1-9/16	5-1/2	94.48	133.00	151.09
15/16	1	1-5/8	5-7/8	112.69	150.00	179.32
1	1	1-5/8	5-7/8	112.69	165.00	179.32

SETS

3/8" SHANK—TWO-FLUTE

6 Piece Set — DOUBLE END
Contains 1 piece of each:
1/8, 5/32, 3/16, 1/4, 5/16, 3/8
Supplied in wood block.

SET NO. 261AT
Import TIN Coated
SET PRICE — \$199.20

SET NO. 261ATU
USA TIN Coated
SET PRICE — \$249.00

SET NO. 261ATAU
USA TIAN Coated
SET PRICE — \$337.00

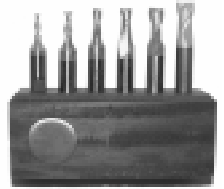

FOUR FLUTE

- LIST NO. 241T — QUALITY IMPORT TIN COATED
- LIST NO. 241TU — MADE IN U.S.A. TIN COATED
- LIST NO. 241TAU — MADE IN U.S.A. TIAN COATED



Dia. of Cut	Shank Dia.	Length of Cut	Overall Length	Price Each		
				List No. 241T	List No. 241TU	List No. 241TAU
1/8	3/8	3/8	3-1/16	33.48	41.50	56.54
5/32	3/8	7/16	3-1/8	34.28	42.50	57.78
3/16	3/8	1/2	3-1/4	33.48	41.50	56.54
7/32	3/8	9/16	3-1/4	34.28	42.50	57.78
1/4	3/8	5/8	3-3/8	33.48	41.50	56.54
9/32	3/8	11/16	3-3/8	34.28	42.50	57.78
5/16	3/8	3/4	3-1/2	33.48	41.50	56.54
11/32	3/8	3/4	3-1/2	34.28	42.50	57.78
3/8	3/8	3/4	3-1/2	33.48	41.50	56.54
13/32	1/2	1	4-1/8	47.37	63.00	78.07
7/16	1/2	1	4-1/8	48.97	61.50	80.55
15/32	1/2	1	4-1/8	50.17	63.17	82.41
1/2	1/2	1	4-1/8	49.37	61.37	81.17
9/16	5/8	1-3/8	5	63.33	86.33	102.81
5/8	5/8	1-3/8	5	62.73	89.73	101.88
11/16	3/4	1-5/8	5-5/8	78.01	112.00	125.57
3/4	3/4	1-5/8	5-5/8	79.01	112.00	127.12
13/16	7/8	1-7/8	6-1/8	95.48	136.48	152.64
7/8	7/8	1-7/8	6-1/8	94.48	137.00	151.09
15/16	1	1-7/8	6-3/8	103.69	163.00	165.37
1	1	1-7/8	6-3/8	112.69	163.00	179.32

SETS

3/8" SHANK—FOUR-FLUTE

6 Piece Set — DOUBLE END
Contains 1 piece of each:
1/8, 5/32, 3/16, 1/4, 5/16, 3/8
Supplied in wood block.

SET NO. 241AT
Import TIN Coated
SET PRICE — \$199.70

SET NO. 241ATU
USA TIN Coated
SET PRICE — \$249.00

SET NO. 241ATAU
USA TIAN Coated
SET PRICE — \$340.00



◆ END MILL HOLDERS

These End Mill Holders are made of alloy forged steel for a more durable service life.

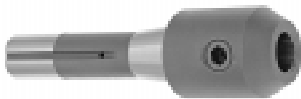

R-8 END MILL ADAPTERS			
Shank	Hole Diameter	Tool No.	Price Each
R8	3/16	R8E316	36.50
R8	3/8	R8E38	36.50
R8	1/2	R8E12	37.00
R8	5/8	R8E58	39.00
R8	3/4	R8E34	42.00
R8	7/8	R8E78	46.00
R8	1	R8E1	46.00
R8	1-1/4	R8E114	60.75
R8	1-1/2	R8E112	69.50

R-8 END MILL ADAPTER SET SET NO. R8EM
6 Piece Set
Contains 1 piece of each:
3/16, 3/8, 1/2, 5/8, 3/4, 1"
Supplied in wood block.
SET PRICE — \$229.00

END MILL HOLDERS						
Hole Dia.	No. 30 Taper		No. 40 Taper		No. 50 Taper	
	Tool No.	Price Each	Tool No.	Price Each	Tool No.	Price Each
3/16	H30316	49.00	H40316	57.00	—	—
3/8	H3038	49.00	H4038	57.00	H5038	88.00
1/2	H3012	49.00	H4012	57.00	H5012	88.00
5/8	H3058	49.00	H4058	57.00	H5058	88.00
3/4	H3034	55.00	H4034	57.00	H5034	88.00
7/8	H3078	60.00	H4078	65.00	H5078	98.00
1	H301	60.00	H401	65.00	H501	98.00
1-1/4	—	—	H40114	69.00	H50114	98.00
1-1/2	—	—	H40112	78.00	H50112	150.00
2	—	—	—	—	H502	160.00
2-1/2	—	—	—	—	H50212	180.00

MINIATURE DOUBLE-END END MILLS

REGULAR LENGTH — 3/16" SHANK

2-1/4" OVERALL LENGTH

● LIST NO. 265 — TWO FLUTE

● LIST NO. 245 — FOUR FLUTE



Diameter of Cut	Two Flute List No. 265		Four Flute List No. 245	
	Length of Cut	Price Each	Length of Cut	Price Each
1/32	1/8	19.45	—	—
3/64	9/64	19.45	—	—
1/16	3/16	18.15	3/16	16.95
5/64	15/64	18.15	15/64	16.95
3/32	9/32	17.40	9/32	16.95
7/64	21/64	17.40	21/64	16.95
1/8	3/8	17.40	3/8	16.95
9/64	13/32	17.40	13/32	16.95
5/32	7/16	17.40	7/16	16.95
11/64	1/2	17.40	1/2	16.95
3/16	1/2	17.40	1/2	16.95

SET NO. 265A

TWO FLUTE

3/16" SHANKS

5 Piece Set

Contains 1 piece of each:

1/16, 3/32, 1/8, 5/32, 3/16

Supplied in wood block.

SET PRICE — \$87.50

SET NO. 245A

FOUR FLUTE

3/16" SHANKS

5 Piece Set

Contains 1 piece of each:

1/16, 3/32, 1/8, 5/32, 3/16

Supplied in wood block.

SET PRICE — \$84.50

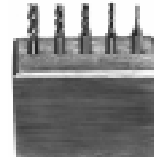
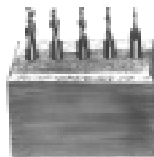

LONG LENGTH — 3/16" SHANK

● LIST NO. 266 — TWO FLUTE



● LIST NO. 246 — FOUR FLUTE



STUB LENGTH — 3/16" SHANK

● LIST NO. 266S — TWO FLUTE



● LIST NO. 246S — FOUR FLUTE



Diameter of Cut	Length of Cut	Overall Length	Price Each	
			Two Flute List No. 266	Four Flute List No. 246
1/16	7/32	2-1/2	21.60	21.90
5/64	7/32	2-1/2	21.60	21.90
3/32	9/32	2-5/8	21.60	21.90
1/8	3/4	3-1/8	21.60	21.90
9/64	3/4	3-1/8	21.60	21.90
5/32	7/8	3-1/4	21.60	21.90
3/16	1	3-3/8	21.60	21.90

Diameter of Cut	Length of Cut	Overall Length	Price Each	
			Two Flute List No. 266S	Four Flute List No. 246S
1/32	3/64	2	18.05	—
1/16	3/32	2	15.85	16.05
5/64	1/8	2	15.85	16.05
3/32	9/64	2	15.60	16.05
7/64	5/32	2	15.60	—
1/8	3/16	2	15.60	16.05
9/64	7/32	2	15.60	16.05
5/32	15/64	2	15.60	16.05
11/64	1/4	2	15.60	16.05
3/16	9/32	2	15.60	16.05

MINIATURE *Cobalt* DOUBLE-END END MILLS

REGULAR LENGTH — 3/16" SHANK

2-1/4" OVERALL LENGTH

● LIST NO. 265C — TWO FLUTE

● LIST NO. 245C — FOUR FLUTE, CENTER CUT



Diameter of Cut	Two Flute List No. 265C		Four Flute List No. 245C	
	Length of Cut	Price Each	Length of Cut	Price Each
1/32	1/8	29.90	—	—
3/64	9/64	29.90	—	—
1/16	3/16	29.90	3/16	29.90
5/64	15/64	29.90	15/64	29.90
3/32	9/32	29.90	9/32	29.90
7/64	21/64	29.90	21/64	29.90
1/8	3/8	29.90	3/8	29.90
9/64	13/32	29.90	13/32	29.90
5/32	7/16	29.90	7/16	29.90
11/64	1/2	29.90	1/2	29.90
3/16	1/2	29.90	1/2	29.90

SET NO. 265CA

COBALT

3/16" SHANKS

5 Piece Set

Contains 1 piece of each:

1/16, 3/32, 1/8, 5/32, 3/16

Supplied in wood block.

SET PRICE — \$149.00

SET NO. 245CA

COBALT

3/16" SHANKS

5 Piece Set

Contains 1 piece of each:

1/16, 3/32, 1/8, 5/32, 3/16

Supplied in wood block.

SET PRICE — \$149.00

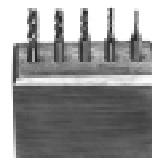
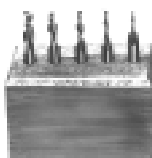

HIGH SPEED STEEL

BALL-END END MILLS

TWO FLUTE, REGULAR LENGTH

- ▶ LIST NO. 291 — QUALITY IMPORT
- LIST NO. 291U — MADE IN U.S.A.



Diameter of Cut	Shank Diameter	Two Flute Regular Length			
		Length of Cut	Overall Length	Price Each	
				List No. 291	List No. 291U
1/8	3/8	3/8	2-5/16	20.40	23.00
3/16	3/8	1/2	2-3/8	20.40	23.00
1/4	3/8	5/8	2-7/16	20.40	23.00
5/16	3/8	3/4	2-1/2	23.00	26.00
3/8	3/8	3/4	2-1/2	23.00	26.00
7/16	1/2	1	3	30.20	34.12
1/2	1/2	1	3	30.20	34.12
9/16	1/2	1-1/8	3-1/8	39.00	44.50
5/8	1/2	1-1/8	3-1/8	45.00	50.85
5/8	5/8	1-3/8	3-1/2	45.00	50.85
3/4	1/2	1-5/16	3-5/16	53.00	59.50
3/4	3/4	1-5/8	3-7/8	53.00	59.50
7/8	7/8	2	4-1/4	68.00	76.85
1	1	2-1/4	4-3/4	85.00	96.00
1-1/8	1	2-1/4	4-3/4	100.00	129.00
1-1/4	1-1/4	2-1/2	5	116.00	131.00
1-3/8	1-1/4	2-1/2	5	130.20	142.00
1-1/2	1-1/4	2-1/2	5	142.00	160.50
2	1-1/4	2-1/2	5	229.00	257.50

SINGLE END

TWO FLUTE, EXTENSION TYPE

- ▶ LIST NO. 293 — QUALITY IMPORT
- LIST NO. 293U — MADE IN U.S.A.

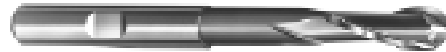

Diameter of Cut	Shank Diameter	Two Flute Extension			
		Length of Cut	Overall Length	Price Each	
				List No. 293	List No. 293U
1/8	3/8	3/8	2-3/8	24.72	34.50
3/16	3/8	1/2	2-11/16	24.72	34.50
1/4	3/8	5/8	3-1/16	25.75	34.50
5/16	3/8	3/4	3-5/16	30.43	37.70
3/8	3/8	3/4	3-5/16	29.66	37.70
7/16	1/2	1	3	—	49.60
1/2	1/2	1	4	39.90	46.20
5/8	5/8	1-3/8	4-5/8	54.40	75.00
3/4	3/4	1-5/8	5-3/8	66.50	91.00
7/8	7/8	2	6	80.70	92.20
1	1	2-1/2	7-1/4	106.00	145.00
1-1/4	1-1/4	3	7-1/4	133.50	165.00

SETS

2 Flute - Ball End
6 Piece Set
Contains 1 piece of each:
1/8, 3/16, 1/4,
5/16, 3/8, 1/2
Supplied in wood block.

SET NO. 291AS
QUALITY IMPORT
SET PRICE — \$137.40

SET NO. 291AUS
MADE IN USA
SET PRICE — \$155.12

CENTER CUTTING

FOUR FLUTE, REGULAR LENGTH

- LIST NO. 294 — QUALITY IMPORT



Diameter of Cut	Shank Diameter	Four Flute Regular Length		
		Length of Cut	Overall Length	Price Each
1/4	3/8	5/8	2-7/16	31.00
5/16	3/8	3/4	2-1/2	31.00
3/8	3/8	3/4	2-1/2	31.00
7/16	1/2	1-1/4	3-1/4	34.50
1/2	1/2	1-1/4	3-1/4	36.00
5/8	5/8	1-5/8	3-3/4	54.00
3/4	3/4	1-5/8	3-7/8	63.00
7/8	7/8	1-7/8	4-1/8	88.00
1	1	2	4-1/2	104.00
1-1/4*	1-1/4	2	4-1/2	124.00
1-1/2*	1-1/4	2	4-1/2	170.00

* 6 Flutes

CENTER CUTTING

FOUR FLUTE, LONG LENGTH

- LIST NO. 294L — QUALITY IMPORT



Diameter of Cut	Shank Diameter	Four Flute Long Length		
		Length of Cut	Overall Length	Price Each
1/4	3/8	1-1/4	3-1/16	36.27
5/16	3/8	1-3/8	3-1/8	36.27
3/8	3/8	1-1/2	3-1/4	37.80
1/2	1/2	2	4	50.00
5/8	5/8	2-1/2	4-5/8	66.60
3/4	3/4	3	5-1/4	76.00
1	1	4	6-1/2	126.60
1-1/4*	1-1/4	4	6-1/2	150.80
1-1/2*	1-1/4	4	6-1/2	206.60

* 6 Flutes

HIGH SPEED STEEL

BALL-END END MILLS

REGULAR LENGTH, 3/16" SHANK

- LIST NO. 268 — TWO FLUTE, MINIATURE



LONG LENGTH, 3/16" SHANK

- LIST NO. 269 — TWO FLUTE, MINIATURE
(Not Pictured)

Dia. of Cut	Shank Dia.	Regular Length List No. 268			Long Length List No. 269		
		Length of Cut	Overall Length	Price Each	Length of Cut	Overall Length	Price Each
1/32	3/16	1/8	2-1/4	28.50	—	—	—
3/64	3/16	9/64	2-1/4	28.50	—	—	—
1/16	3/16	3/16	2-1/4	28.60	7/32	2-1/2	35.30
5/64	3/16	15/64	2-1/4	26.45	—	—	—
3/32	3/16	9/32	2-1/4	26.45	9/32	2-5/8	33.85
7/64	3/16	21/64	2-1/4	26.45	—	—	—
1/8	3/16	3/8	2-1/4	26.45	3/4	3-1/8	33.85
9/64	3/16	13/32	2-1/4	26.45	—	—	—
5/32	3/16	7/16	2-1/4	26.45	7/8	3-1/4	33.85
11/64	3/16	1/2	2-1/4	26.45	—	—	—
3/16	3/16	1/2	2-1/4	26.85	1	3-3/8	33.85

DOUBLE END

REGULAR LENGTH

- LIST NO. 292 — TWO FLUTE



Diameter of Cut	Shank Diameter	Flute Length	Overall Length	Price Each
1/8	3/8	3/8	3-1/16	33.00
5/32	3/8	7/16	3-1/8	34.20
3/16	3/8	7/16	3-1/8	33.00
7/32	3/8	1/2	3-1/8	34.20
1/4	3/8	1/2	3-1/8	33.00
9/32	3/8	9/16	3-1/8	34.20
5/16	3/8	9/16	3-1/8	33.00
11/32	3/8	9/16	3-1/8	34.20
3/8	3/8	9/16	3-1/8	33.00
7/16	1/2	13/16	3-3/4	46.00
1/2	1/2	13/16	3-3/4	46.00
9/16	1/2	1-1/8	3-1/8	55.00
5/8	5/8	1-1/8	4-1/2	64.00
3/4	3/4	1-5/16	5	80.00
7/8	7/8	1-9/16	5-1/2	98.52
1	1	1-5/8	5-7/8	122.00

M-42 COBALT END MILLS

SINGLE END



● LIST NO. 231C — TWO FLUTE, REGULAR LENGTH

Diameter of Cut	Shank Diameter	Length of Cut	Overall Length	Price Each
1/8	3/8	3/8	2-5/16	21.40
5/32	3/8	3/8	2-5/16	21.40
3/16	3/8	7/16	2-5/16	21.40
7/32	3/8	1/2	2-5/16	21.40
1/4	3/8	1/2	2-5/16	21.40
9/32	3/8	9/16	2-5/16	21.40
5/16	3/8	9/16	2-5/16	21.40
11/32	3/8	9/16	2-5/16	21.40
3/8	3/8	9/16	2-5/16	21.40
13/32	3/8	13/16	2-1/2	30.20
7/16	3/8	13/16	2-1/2	30.20
15/32	3/8	13/16	2-1/2	30.20
1/2	3/8	13/16	2-1/2	30.20
1/2	1/2	1	3	30.20
9/16	1/2	1-1/8	3-1/8	41.30
5/8	1/2	1-1/8	3-3/8	40.00
5/8	5/8	1-5/16	3-7/16	40.00
11/16	1/2	1-5/16	3-7/16	50.00
11/16	5/8	1-5/16	3-7/16	50.00
3/4	1/2	1-5/16	3-5/8	50.00
3/4	5/8	1-5/16	3-7/16	50.00

Diameter of Cut	Shank Diameter	Length of Cut	Overall Length	Price Each
3/4	3/4	1-5/16	3-9/16	50.00
13/16	5/8	1-1/2	3-5/8	58.80
7/8	3/4	1-1/2	3-3/4	68.60
7/8	7/8	1-1/2	3-3/4	68.60
15/16	3/4	1-1/2	3-3/4	75.00
1	3/4	1-1/2	3-3/4	80.00
1	1	1-5/8	4-1/8	80.00
1-1/16	3/4	1-5/8	3-7/8	108.10
1-1/8	3/4	1-5/8	3-7/8	108.00
1-1/8	1	1-5/8	4-1/8	108.00
1-1/4	3/4	1-5/8	3-7/8	106.00
1-1/4	1	1-5/8	4-1/8	106.00
1-1/4	1-1/4	1-5/8	4-1/8	106.00
1-3/8	3/4	1-5/8	4-1/8	146.80
1-3/8	1	1-5/8	4-1/8	146.80
1-3/8	1-1/4	1-5/8	4-1/8	146.80
1-1/2	3/4	1-5/8	3-7/8	158.50
1-1/2	1	1-5/8	4-1/8	158.50
1-1/2	1-1/4	1-5/8	4-1/8	158.50
1-1/2	1-1/4	1-5/8	4-1/8	190.00
2	1-1/4	1-5/8	4-1/8	207.20

DOUBLE END

For milling abrasive, high strength thermal resistant metals recognized for great abrasive resistance and high red hardness. For higher speeds, feeds and easy resharpening.

● LIST NO. 261C — TWO FLUTE

CENTER CUTTING

● LIST NO. 241C — FOUR FLUTE

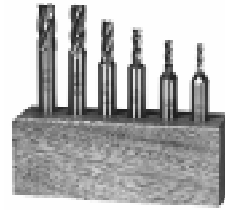

Dia. of Cut	Shank Dia.	Length of Cut	Overall Length	Price Each
1/8	3/8	3/8	3-1/16	29.89
5/32	3/8	7/16	3-1/8	31.60
3/16	3/8	7/16	3-1/8	31.60
7/32	3/8	1/2	3-1/8	31.60
1/4	3/8	1/2	3-1/8	31.60
9/32	3/8	9/16	3-1/8	32.20
5/16	3/8	9/16	3-1/8	31.60
11/32	3/8	9/16	3-1/8	34.70
3/8	3/8	9/16	3-1/8	31.60
13/32	1/2	13/16	3-3/4	42.35
7/16	1/2	13/16	3-3/4	42.35
15/32	1/2	13/16	3-3/4	46.15
1/2	1/2	13/16	3-3/4	46.15
9/16	5/8	1-1/8	4-1/2	65.00
5/8	5/8	1-1/8	4-1/2	73.68
11/16	3/4	1-5/16	5	92.60
3/4	3/4	1-5/16	5	97.50
7/8	7/8	1-9/16	5-1/2	119.00
1	1	1-5/8	5-7/8	139.50

TWO FLUTE DOUBLE END SET NO. 261CS

6 Piece Set
Contains 1 piece of each:
1/8, 3/16, 1/4, 5/16, 3/8, 1/2
Supplied in wood block.
SET PRICE — \$199.00

FOUR FLUTE DOUBLE END SET NO. 241CS

6 Piece Set
Contains 1 piece of each:
1/8, 3/16, 1/4, 5/16, 3/8, 1/2
Supplied in wood block.
SET PRICE — \$195.00

Dia. of Cut	Shank Dia.	Length of Cut	Overall Length	Price Each
1/8	3/8	3/8	3-1/16	29.25
5/32	3/8	7/16	3-1/8	29.25
3/16	3/8	1/2	3-1/4	29.25
7/32	3/8	9/16	3-1/4	29.25
1/4	3/8	5/8	3-3/8	29.25
9/32	3/8	11/16	3-3/8	29.25
5/16	3/8	3/4	3-1/2	29.25
11/32	3/8	3/4	3-1/2	32.00
3/8	3/8	3/4	3-1/2	29.25
13/32	1/2	1	4-1/8	41.00
7/16	1/2	1	4-1/8	41.00
15/32	1/2	1	4-1/8	45.35
1/2	1/2	1	4-1/8	45.35
9/16	5/8	1-3/8	5	61.50
5/8	5/8	1-3/8	5	72.40
11/16	3/4	1-5/8	5-5/8	91.50
3/4	3/4	1-5/8	5-5/8	96.50
7/8	7/8	1-7/8	6-1/8	119.80
1	1	1-7/8	6-3/8	145.50

BALL END

CENTER CUTTING

Dia. of Cut	Shank Dia.	Two Flute Single End List No. 291C			Two Flute Double End List No. 292C			Four Flute Single End List No. 294C		
		Length of Cut	Overall Length	Price Each	Length of Cut	Overall Length	Price Each	Length of Cut	Overall Length	Price Each
1/8	3/8	3/8	2-5/16	30.00	3/8	3-1/16	49.00	3/8	2-5/16	39.00
3/16	3/8	1/2	2-3/8	30.00	7/16	3-1/8	49.00	1/2	2-3/8	42.00
1/4	3/8	5/8	2-7/16	30.00	1/2	3-1/8	49.00	5/8	2-7/16	42.00
5/16	3/8	3/4	2-1/2	33.50	9/16	3-1/8	49.00	3/4	2-1/2	46.00
3/8	3/8	3/4	2-1/2	33.50	9/16	3-1/8	49.00	3/4	2-1/2	46.00
7/16	1/2	3/4	3	45.00	13/16	3-3/4	63.00	1	3	56.00
1/2	1/2	1	3	42.00	13/16	3-3/4	73.60	1-1/4	3-1/4	56.00
9/16	1/2	1-1/8	3-1/8	53.00	1-1/8	4-9/16	118.40	1-1/8	3-1/8	76.00
5/8	1/2	—	—	—	1-5/16	5	156.00	1-1/8	3-1/8	75.50
5/8	5/8	1-3/8	3-1/2	60.00	—	—	—	1-5/8	3-3/4	75.50
3/4	1/2	—	—	—	—	—	—	1-5/16	3-5/16	86.50
3/4	3/4	1-5/8	3-7/8	70.00	—	—	—	1-5/8	3-7/8	86.50
7/8	7/8	2	4-1/4	91.00	—	—	—	1-7/8	4-1/8	119.00
1	1	2-1/4	4-3/4	118.00	—	—	—	2	4-1/2	130.00
1-1/8	1	2-1/4	4-3/4	146.00	—	—	—	2	4-1/2	162.00
1-1/4	1-1/4	2-1/2	5	156.99	—	—	—	2	4-1/2	160.00
1-1/2	1-1/4	2-1/2	5	203.09	—	—	—	2	4-1/2	202.00

● LIST NO. 291C
TWO FLUTE, SINGLE END



● LIST NO. 292C
TWO FLUTE, DOUBLE END



● LIST NO. 294C
FOUR FLUTE, SINGLE END



U.S.A. M-42 **COBALT** END MILLS

SINGLE END CENTER CUTTING



● LIST NO. 231CU — TWO FLUTE, REGULAR LENGTH

Dia. of Cut	Shank Dia.	Length of Cut	Overall Length	Price Each
1/8	3/8	3/8	2-5/16	29.00
5/32	3/8	7/16	2-5/16	29.00
3/16	3/8	7/16	2-5/16	29.00
7/32	3/8	1/2	2-5/16	29.00
1/4	3/8	1/2	2-5/16	29.00
9/32	3/8	9/16	2-5/16	29.00
5/16	3/8	9/16	2-5/16	29.00
11/32	3/8	9/16	2-5/16	29.00
3/8	3/8	9/16	2-5/16	29.00
13/32	3/8	13/16	2-1/2	39.00
7/16	1/2	1	3	39.00
15/32	3/8	13/16	2-1/2	39.00
1/2	3/8	13/16	2-1/2	39.00
1/2	1/2	1	3	39.00

Dia. of Cut	Shank Dia.	Length of Cut	Overall Length	Price Each
9/16	1/2	1-1/8	3-1/8	49.00
5/8	1/2	1-1/8	3-3/8	55.00
5/8	5/8	1-5/16	3-7/16	55.00
3/4	1/2	1-5/16	3-5/8	69.00
3/4	5/8	1-5/16	3-7/16	69.00
3/4	3/4	1-5/16	3-9/16	69.00
7/8	3/4	1-1/2	3-3/4	89.00
7/8	7/8	1-1/2	3-3/4	89.00
1	5/8	1-1/2	4	110.00
1	3/4	1-1/2	3-3/4	110.00
1	1	1-5/8	4-1/8	110.00
1-1/4	1-1/4	1-5/8	4-1/8	139.00
1-1/2	1-1/4	1-5/8	4-1/8	199.00
2	1-1/4	1-5/8	4-1/8	250.00

DOUBLE END CENTER CUTTING

For milling abrasive, high strength thermal resistant metals recognized for great abrasive resistance and high red hardness...for higher speeds, feeds and easy resharpening.

● LIST NO. 261CU — TWO FLUTE



Dia. of Cut	Shank Dia.	Length of Cut	Overall Length	Price Each
1/8	3/8	3/8	3-1/16	39.00
5/32	3/8	7/16	3-1/8	39.00
3/16	3/8	7/16	3-1/8	39.00
7/32	3/8	1/2	3-1/8	39.00
1/4	3/8	1/2	3-1/8	39.00
9/32	3/8	9/16	3-1/8	39.00
5/16	3/8	9/16	3-1/8	39.00
11/32	3/8	9/16	3-1/8	39.00
3/8	3/8	9/16	3-1/8	39.00
13/32	1/2	13/16	3-3/4	49.00
7/16	1/2	13/16	3-3/4	49.00
15/32	1/2	13/16	3-3/4	49.00
1/2	1/2	13/16	3-3/4	58.00
9/16	5/8	1-1/8	4-1/2	69.00
5/8	5/8	1-1/8	4-1/2	77.30
11/16	3/4	1-5/16	5	98.60
3/4	3/4	1-5/16	5	98.60
13/16	7/8	1-9/16	5-1/2	129.00
7/8	7/8	1-9/16	5-1/2	133.00
15/16	1	1-5/8	5-7/8	149.50
1	1	1-5/8	5-7/8	156.70

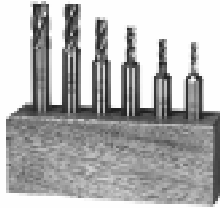

TWO FLUTE DOUBLE END SET NO. 261CUS
6 Piece Set

Contains 1 piece of each:
1/8, 3/16, 1/4, 5/16, 3/8, 1/2
Supplied in wood block.

SET PRICE — \$253.50

FOUR FLUTE DOUBLE END SET NO. 241CUS
6 Piece Set

Contains 1 piece of each:
1/8, 3/16, 1/4, 5/16, 3/8, 1/2
Supplied in wood block.

SET PRICE — \$276.00

● LIST NO. 241CU — FOUR FLUTE



Dia. of Cut	Shank Dia.	Length of Cut	Overall Length	Price Each
1/8	3/8	3/8	3-1/16	42.00
5/32	3/8	7/16	3-1/8	42.00
3/16	3/8	7/16	3-1/4	42.00
7/32	3/8	9/16	3-1/4	42.00
1/4	3/8	5/8	3-3/8	42.00
9/32	3/8	11/16	3-3/8	42.00
5/16	3/8	3/4	3-1/2	42.00
11/32	3/8	3/4	3-1/2	42.00
3/8	3/8	3/4	3-1/2	42.00
13/32	1/2	1	4-1/8	55.00
7/16	1/2	1	4-1/8	55.00
15/32	1/2	1	4-1/8	66.00
1/2	1/2	1	4-1/8	66.00
9/16	5/8	1-3/8	5	79.00
5/8	5/8	1-3/8	5	94.00
11/16	3/4	1-5/8	5-5/8	105.50
3/4	3/4	1-5/8	5-5/8	112.00
13/16	7/8	1-7/8	6-1/8	135.00
7/8	7/8	1-7/8	6-1/8	145.00
15/16	1	1-7/8	6-3/8	184.00
1	1	1-7/8	6-3/8	184.00

BALL END CENTER CUTTING

Dia. of Cut	Shank Dia.	Two Flute List No. 291CU			Four Flute List No. 294CU		
		Length of Cut	Overall Length	Price Each	Length of Cut	Overall Length	Price Each
1/8	3/8	3/8	2-5/16	36.00	3/8	2-5/16	54.00
3/16	3/8	1/2	2-3/8	37.00	1/2	2-3/8	54.00
1/4	3/8	5/8	2-7/16	37.00	5/8	2-7/16	54.00
5/16	3/8	3/4	2-1/2	39.00	3/4	2-1/2	59.00
3/8	3/8	3/4	2-1/2	41.50	3/4	2-1/2	59.00
7/16	1/2	3/4	3	49.00	—	—	—
1/2	1/2	1	3	58.00	1-1/4	3-1/4	78.00
5/8	5/8	1-3/8	3-1/2	84.00	1-5/8	3-3/4	96.00
3/4	3/4	1-5/8	3-7/8	98.00	1-5/8	3-7/8	109.00
7/8	3/4	2	4-1/4	125.00	—	—	—
1	1	2-1/4	4-3/4	145.00	2	4-1/2	179.00
1-1/4	1-1/4	2-1/4	4-3/4	189.00	2	4-1/2	199.00
1-1/2	1-1/4	2-1/2	5	250.00	2	4-1/2	260.00

● LIST NO. 291CU
TWO FLUTE, SINGLE END



● LIST NO. 294CU
FOUR FLUTE, SINGLE END



U.S.A. M-42 *Cobalt* END MILLS

CENTER CUTTING — SINGLE END — MULTI-FLUTE

- LIST NO. 205CU
REGULAR LENGTH



- LIST NO. 206CU
LONG LENGTH



- LIST NO. 207CU
EXTRA LONG LENGTH

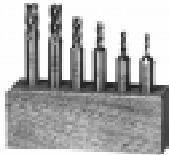

**FOUR FLUTE — 3/8" SHANK
SET NO. 205CAU**

6 Piece Set — REGULAR LENGTH
Contains 1 piece of each:
1/8, 3/16, 1/4, 5/16, 3/8, 1/2
Supplied in wood block.
SET PRICE — \$189.90

Dia. of Cut	Shank Dia.	Regular Length List No. 205CU				Long Length List No. 206CU			Extra Long Length List No. 207CU		
		No. of Flutes	Flute Length	Overall Length	Price Each	Flute Length	Overall Length	Price Each	Flute Length	Overall Length	Price Each
1/8	3/8	4	3/8	2-5/16	29.00	—	—	—	—	—	—
3/16	3/8	4	1/2	2-3/8	29.00	—	—	—	—	—	—
1/4	3/8	4	5/8	2-7/16	29.00	1-1/4	3-1/8	39.50	1-3/4	3-9/16	47.00
5/16	3/8	4	3/4	2-1/2	29.00	1-3/8	3-1/8	39.50	2	3-3/4	47.00
3/8	3/8	4	3/4	2-1/2	29.00	1-1/2	3-1/4	39.50	2-1/2	4-1/4	47.00
7/16	3/8	4	1	2-11/16	42.00	—	—	—	—	—	—
1/2	3/8	4	1	2-11/16	44.90	—	—	—	—	—	—
1/2	1/2	4	1-1/4	3-1/4	44.90	2	4	52.50	3	5	62.00
9/16	1/2	4	1-3/8	3-3/8	55.00	—	—	—	—	—	—
5/8	1/2	4	1-3/8	3-3/8	65.00	—	—	—	—	—	—
5/8	5/8	4	1-5/8	3-3/4	65.00	2-1/2	4-5/8	78.00	4	6-1/8	97.50
3/4	3/4	4	1-5/8	3-7/8	79.00	3	5-1/4	97.00	4	6-1/4	115.00
7/8	3/4	4	1-7/8	4-1/8	105.00	—	—	—	—	—	—
7/8	7/8	4	1-7/8	4-1/8	105.00	3-1/2	5-3/4	120.00	—	—	—
1	1	4	2	4-1/2	125.00	4	6-1/2	159.00	6	8-1/2	195.00
1	1	6	—	—	—	4	6-1/2	159.00	—	—	—
1-1/8	3/4	6	1-1/2	3-7/8	175.00	—	—	—	—	—	—
1-1/4	3/4	6	1-1/2	3-7/8	160.00	—	—	—	—	—	—
1-1/4	1-1/4	4	2	4-1/2	160.00	4	6-1/2	225.00	6	8-1/2	235.00
1-1/4	1-1/4	6	2	4-1/2	160.00	4	6-1/2	225.00	6	8-1/2	275.00
1-3/8	3/4	6	1-1/2	3-7/8	170.00	—	—	—	—	—	—
1-1/2	3/4	6	1-1/2	3-7/8	210.00	—	—	—	—	—	—
1-1/2	1-1/4	4	2	4-1/2	210.00	—	—	—	6	10-1/2	350.00
1-1/2	1-1/4	6	2	4-1/2	210.00	—	—	—	—	—	—
1-3/4	1-1/4	6	2	4-1/2	390.00	—	—	—	—	—	—
2	1-1/4	6	2	4-1/2	450.00	—	—	—	—	—	—

COATED U.S.A. M-42 *Cobalt* END MILLS

CENTER CUTTING — SINGLE END — MULTI-FLUTE

- LIST NO. 205CUT — REGULAR LENGTH, TiN Coated
- LIST NO. 205CUA — REGULAR LENGTH, TiAlN
- LIST NO. 206CUT — LONG LENGTH, TiN Coated
- LIST NO. 206CUA — LONG LENGTH, TiAlN
- LIST NO. 207CUT — EXTRA LONG LENGTH, TiN Coated
- LIST NO. 207CUA — EXTRA LONG LENGTH, TiAlN



Dia. of Cut	Shank Dia.	Regular Length					Long Length				Extra Long Length			
		No. of Flutes	Flute Length	Overall Length	Price Each		Flute Length	Overall Length	Price Each		Flute Length	Overall Length	Price Each	
					List No. 205CUTC	List No. 205CUTA			List No. 206CUTC	List No. 206CUTA			List No. 207CUTC	List No. 207CUTA
1/8	3/8	4	3/8	2-5/16	39.00	54.60	—	—	—	—	—	—	—	—
3/16	3/8	4	1/2	2-3/8	39.00	54.60	—	—	—	—	—	—	—	—
1/4	3/8	4	5/8	2-7/16	39.00	54.60	1-1/4	3-1/8	50.00	70.00	1-3/4	3-9/16	60.00	84.00
5/16	3/8	4	3/4	2-1/2	39.00	54.60	1-3/8	3-1/8	50.00	70.00	2	3-3/4	60.00	84.00
3/8	3/8	4	3/4	2-1/2	39.00	54.60	1-1/2	3-1/4	50.00	70.00	2-1/2	4-1/4	60.00	84.00
7/16	3/8	4	1	2-11/16	52.00	72.80	—	—	—	—	—	—	—	—
1/2	3/8	4	1	2-11/16	60.90	85.26	—	—	—	—	—	—	—	—
1/2	1/2	4	1-1/4	3-1/4	60.90	85.26	2	4	70.50	98.70	3	5	80.00	112.00
9/16	1/2	4	1-3/8	3-3/8	71.00	99.40	—	—	—	—	—	—	—	—
5/8	1/2	4	1-3/8	3-3/8	81.00	113.00	—	—	—	—	—	—	—	—
5/8	5/8	4	1-5/8	3-3/4	81.00	113.00	2-1/2	4-5/8	103.00	144.20	4	6-1/8	127.50	178.50
3/4	3/4	4	1-5/8	3-7/8	105.00	147.00	3	5-1/4	129.00	180.60	4	6-1/4	145.00	203.00
7/8	3/4	4	1-7/8	4-1/8	131.00	183.40	—	—	—	—	—	—	—	—
7/8	7/8	4	1-7/8	4-1/8	131.00	183.40	3-1/2	5-3/4	160.00	224.00	—	—	—	—
1	1	4	2	4-1/2	151.00	211.00	4	6-1/2	204.00	285.60	6	8-1/2	255.00	357.00
1	1	6	—	—	—	—	4	6-1/2	204.00	285.60	—	—	—	—
1-1/8	3/4	6	1-1/2	3-7/8	201.00	281.00	—	—	—	—	—	—	—	—
1-1/4	3/4	6	1-1/2	3-7/8	186.00	260.40	—	—	—	—	—	—	—	—
1-1/4	1-1/4	4	2	4-1/2	186.00	260.40	4	6-1/2	285.00	399.00	6	8-1/2	347.00	485.80
1-1/4	1-1/4	6	2	4-1/2	186.00	260.40	4	6-1/2	285.00	399.00	6	8-1/2	347.00	485.80
1-3/8	3/4	6	1-1/2	3-7/8	186.00	260.40	—	—	—	—	—	—	—	—
1-1/2	3/4	6	1-1/2	3-7/8	209.00	292.60	—	—	—	—	—	—	—	—
1-1/2	1-1/4	4	2	4-1/2	249.00	348.60	—	—	—	—	6	10-1/2	386.00	540.40
1-1/2	1-1/4	6	2	4-1/2	249.00	348.60	—	—	—	—	—	—	—	—
1-3/4	1-1/4	6	2	4-1/2	429.00	600.00	—	—	—	—	—	—	—	—
2	1-1/4	6	2	4-1/2	489.00	684.60	—	—	—	—	—	—	—	—

M-42 COBALT END MILLS

CENTER CUTTING — MULTI-FLUTE

● LIST NO. 205C
REGULAR LENGTH



● LIST NO. 206C
LONG LENGTH



● LIST NO. 207C
EXTRA LONG LENGTH



**FOUR FLUTE — 3/8" SHANK
SET NO. 205CA**

6 Piece Set — REGULAR LENGTH

Contains 1 piece of each:

1/8, 3/16, 1/4, 5/16, 3/8, 1/2

Supplied in wood block.

SET PRICE — \$140.25

Dia. of Cut	Shank Dia.	Regular Length List No. 205C				Long Length List No. 206C			Extra Long Length List No. 207C		
		No. of Flutes	Flute Length	Overall Length	Price Each	Flute Length	Overall Length	Price Each	Flute Length	Overall Length	Price Each
1/8	3/8	4	3/8	2-5/16	21.60	—	—	—	—	—	—
5/32	3/8	4	7/16	2-1/4	21.60	—	—	—	—	—	—
3/16	3/8	4	1/2	2-3/8	21.60	—	—	—	—	—	—
7/32	3/8	4	5/8	2-3/8	21.60	—	—	—	—	—	—
1/4	3/8	4	5/8	2-7/16	21.60	1-1/4	3-1/16	31.00	1-3/4	3-9/16	34.30
9/32	3/8	4	3/4	2-1/2	21.60	—	—	—	—	—	—
5/16	3/8	4	3/4	2-1/2	21.60	1-3/8	3-1/8	31.00	2	3-3/4	34.30
11/32	3/8	4	3/4	2-1/2	21.60	—	—	—	—	—	—
3/8	3/8	4	3/4	2-1/2	21.60	1-1/2	3-1/4	31.00	2-1/2	4-1/4	37.00
13/32	3/8	4	1	2-11/16	32.25	—	—	—	—	—	—
7/16	3/8	4	1	2-11/16	32.25	—	—	—	—	—	—
15/32	3/8	4	1	2-11/16	32.25	—	—	—	—	—	—
1/2	3/8	4	1	2-11/16	32.25	—	—	—	—	—	—
1/2	1/2	4	1-1/4	3-1/4	33.80	2	4	41.00	3	5	48.00
9/16	1/2	4	1-3/8	3-3/8	48.00	—	—	—	—	—	—
5/8	1/2	4	1-3/8	3-3/8	48.00	—	—	—	—	—	—
5/8	5/8	4	1-5/8	3-3/4	48.00	2-1/2	4-5/8	60.00	4	6-1/8	79.50
11/16	5/8	4	1-5/8	3-3/4	66.00	—	—	—	—	—	—
3/4	1/2	4	1-5/8	3-5/8	60.00	—	—	—	—	—	—
3/4	5/8	4	1-5/8	3-3/4	60.00	—	—	—	—	—	—
3/4	3/4	4	1-5/8	3-7/8	60.00	3	5-1/4	75.00	4	6-1/4	88.75
13/16	3/4	4	1-7/8	4-1/8	76.90	—	—	—	—	—	—
7/8	3/4	4	1-7/8	4-1/8	76.90	—	—	—	—	—	—
7/8	7/8	4	1-7/8	4-1/8	76.90	3-1/2	5-3/4	91.00	—	—	—
15/16	3/4	4	1-7/8	4-1/8	88.00	—	—	—	—	—	—
1	5/8	6	1-7/8	4	92.00	—	—	—	—	—	—
1	3/4	4	1-7/8	4-1/8	92.00	—	—	—	—	—	—
1	1	4	2	4-1/2	92.00	4	6-1/2	120.00	6	8-1/2	150.00
1-1/16	3/4	6	2	4-1/4	132.00	—	—	—	—	—	—
1-1/8	3/4	6	2	4-1/2	132.00	—	—	—	—	—	—
1-1/8	1	4	2	4-1/2	132.00	—	—	—	—	—	—
1-1/8	1	6	2	4-1/2	132.00	4	6-1/2	170.00	—	—	—
1-3/16	3/4	6	2	4-1/2	120.00	—	—	—	—	—	—
1-1/4	3/4	6	2	4-1/4	120.00	—	—	—	—	—	—
1-1/4	1-1/4	4	2	4-1/2	120.00	4	6-1/2	170.00	6	8-1/2	212.00
1-1/4	1-1/4	6	2	4-1/2	120.00	4	6-1/2	170.00	—	—	—
1-5/16	3/4	6	2	4-1/2	130.00	—	—	—	—	—	—
1-3/8	3/4	6	2	4-1/2	130.00	—	—	—	—	—	—
1-7/16	3/4	6	2	4-1/2	156.00	—	—	—	—	—	—
1-1/2	3/4	6	2	4-1/2	156.00	—	—	—	—	—	—
1-1/2	1-1/4	4	2	4-1/2	156.00	—	—	—	—	—	—
1-1/2	1-1/4	6	2	4-1/2	156.00	4	6-1/2	259.00	8	10-1/2	285.00
1-3/4	1-1/4	4	2	4-1/2	235.00	4	6-1/2	298.80	—	—	—
1-3/4	1-1/4	6	2	4-1/2	235.00	—	—	—	—	—	—
2	1-1/4	4	—	—	—	4	6-1/2	327.00	—	—	—
2	1-1/4	6	2	4-1/2	283.00	6	6-1/2	327.00	—	—	—

M2-AL ROUGHING END MILLS

The aluminum content of the M2-AL rougher reduces friction during cutting allowing the rougher to run cooler and last longer.



Specially formulated H.S. Steel which in many application rivals the performance of Cobalt. The cost is significantly lower than Cobalt roughers

◆ REGULAR LENGTH

Cutter Dia.	Shank Dia.	Length of Cut	Overall Length	No. of Flutes	Tool No.	Price Each
1/4	3/8	5/8	2-7/16	4	ALRM8-3	9.38
5/16	3/8	3/4	2-1/2	4	ALRM10-3	9.38
3/8	3/8	3/4	2-1/2	4	ALRM12-3	9.38
7/16	3/8	1	2-11/16	4	ALRM14-3	12.15
1/2	1/2	1-1/4	3-1/4	4	ALR16-4	12.93
5/8	5/8	1-5/8	3-3/4	4	ALR20-5	14.57
3/4	3/4	1-5/8	3-3/4	4	ALR24-6	18.06
7/8	3/4	1-5/8	4-1/8	4	ALR28-6	23.36
1	3/4	2	4-1/2	6	ALR32-6	26.17
1	1	2	4-1/2	6	ALR32-8	26.17
1-1/8	1	2	4-1/2	6	ALR36-8	33.98
1-1/4	1-1/4	2	4-1/2	6	ALR40-10	38.97
1-1/2	1-1/4	2	4-1/2	6	ALR48-10	51.72
2	1-1/4	2	4-1/2	8	ALR64-10	77.98

◆ LONG LENGTH

Cutter Dia.	Shank Dia.	Length of Cut	Overall Length	No. of Flutes	Tool No.	Price Each
1/2	1/2	2	4	4	ALL16-4	16.77
5/8	5/8	2-1/2	4-5/8	4	ALL20-5	16.77
3/4	3/4	3	5-1/4	4	ALL24-6	22.66
7/8	3/4	3-1/2	5-5/8	4	ALL28-6	27.53
1	1	4	6-1/2	6	ALL32-8	31.30
1-1/4	1-1/4	4	6-1/2	6	ALL40-10	51.68
1-1/2	1-1/4	4	6-1/2	6	ALL48-10	63.15
2	1-1/4	4	6-1/2	6	ALL64-10	94.59

Chipmaster **COBALT** ROUGHING END MILLS



► ROUGH PROFILE

For deeper slotting or heavy side cuts.
For general purpose applications in steel.

● FINE PROFILE

For shallow slotting or peripheral milling.
Recommended for use in exotic materials.

Standard Length					Rough Profile		Fine Profile	
Cutter Dia.	Shank Dia.	Length of Cut	Overall Length	No. of Flutes	Tool Number	Price Each	Tool Number	Price Each
1/4	3/8	5/8	2-7/16	4	CR8-3	39.80	CRF8-3	39.80
5/16	3/8	3/4	2-1/2	4	CR10-3	39.80	CRF10-3	39.80
3/8	3/8	3/4	2-1/2	4	CR12-3	41.00	CRF12-3	41.00
7/16	3/8	1	2-11/16	4	CR14-3	49.95	CRF14-3	49.95
1/2	1/2	1-1/4	3-1/4	4	CR16-4	56.00	CRF16-4	56.00
9/16	1/2	1-3/8	3-3/8	4	CR18-4	61.90	CRF18-4	61.90
5/8	5/8	1-5/8	3-3/4	4	CR20-5	69.50	CRF20-5	69.50
11/16	5/8	1-5/8	3-3/4	4	CR22-5	74.50	CRF22-5	74.50
3/4	5/8	1-5/8	3-3/4	4	CR24-5	80.69	CRF24-5	80.69
3/4	3/4	1-5/8	3-3/4	4	CR24-6	89.85	CRF24-6	89.85
13/16	3/4	1-5/8	3-3/4	4	CR26-6	90.50	CRF26-6	90.50
7/8	3/4	1-5/8	4-1/8	5	CR28-6	90.50	CRF28-6	90.50
7/8	7/8	1-7/8	4-1/8	5	CR28-7	90.50	CRF28-7	90.50
15/16	7/8	1-7/8	4-1/8	4	CR30-7	118.38	—	—
1	3/4	2	4-1/2	5	CR32-6	123.75	CRF32-6	123.75
1	1	2	4-1/2	5	CR32-8	123.75	CRF32-8	123.75
1-1/8	3/4	2	4-1/4	5	CR36-6	131.25	—	—
1-1/8	1	2	4-1/2	6	CR36-8	131.25	CRF36-8	131.25
1-1/4	3/4	2	4-1/4	6	CR40-6	152.50	—	—
1-1/4	1	2	4-1/2	5	CR40-8	152.50	—	—
1-1/4	1-1/4	2	4-1/2	6	CR40-10	152.50	CRF40-10	152.50
1-1/2	3/4	2	4-1/4	6	CR48-6	196.95	—	—
1-1/2	1-1/4	2	4-1/2	6	CR48-10	196.95	CRF48-10	196.95
1-3/4	1-1/4	2	4-1/2	6	CR56-10	229.10	CRF56-10	229.10
2	3/4	2	4-1/2	8	CR64-6	267.75	—	—
2	1-1/4	2	4-1/2	8	CR64-10	267.75	—	—
2	2*	2	5-3/4	8	CR64-162	275.00	—	—
2	2*	3	4-3/4	8	CR64-163	295.75	—	—
2	2*	4	7-3/4	8	CR64-164	339.00	—	—
Medium Length					Rough Profile		Fine Profile	
1	1	3	5-1/2	5	CM32-8	121.50	CMF32-8	121.50
1-1/4	1-1/4	3	5-1/2	6	CM40-10	155.70	—	—
1-1/2	1-1/4	3	5-1/2	6	CM48-10	203.25	—	—
2	2*	5	8-3/4	8	CM64-165	386.66	—	—
2	2*	6	9-3/4	8	CM64-166	410.00	—	—
Long Length					Rough Profile		Fine Profile	
1/2	1/2	2	4	4	CL16-4	64.80	—	—
5/8	5/8	2-1/2	4-5/8	4	CL20-5	89.50	CLF20-5	89.50
3/4	5/8	3	5-1/8	4	CL24-5	99.95	—	—
3/4	3/4	3	5-1/4	4	CL24-6	99.95	CLF24-6	99.95
7/8	3/4	3-1/2	5-5/8	4	CL28-6	126.75	—	—
7/8	7/8	3-1/2	5-3/4	4	CL28-7	126.75	—	—
1	1	4	6-1/2	6	CL32-8	135.95	CLF32-8	135.95
1-1/4	3/4	4	6-1/4	6	CL40-6	185.75	—	—
1-1/4	1-1/4	4	6-1/2	6	CL40-10	185.75	CLF40-10	185.75
1-1/2	1-1/4	4	6-1/2	6	CL48-10	240.00	—	—
1-1/2	3/4	4	6-1/4	6	CL48-6	240.00	—	—
1-3/4	1-1/4	4	6-1/2	8	CL56-10	321.50	—	—
2	1-1/4	4	6-1/2	6	CL64-10	414.50	—	—
2	2*	7	10-3/4	8	CL64-167	557.00	—	—
2	2*	8	11-3/4	8	CL64-168	690.00	—	—
2	2*	12	15-3/4	8	CL64-162	895.00	—	—
Extra Long Length					Rough Profile		Fine Profile	
1	1	6	8-1/2	6	CX32-8	179.80	—	—
1-1/4	1-1/4	6	8-1/2	6	CX40-10	238.00	—	—
1-1/2	1-1/4	5	7-1/2	6	CX48-10	238.00	—	—
1-1/2	1-1/4	6	8-1/2	6	CX48-10L	349.00	—	—

* Supplied with combination shanks.



● 3 FLUTE HIGH HELIX CENTER CUT

For use in aluminum and other nonferrous materials.

Three Flute					
Cutter Dia.	Shank Dia.	Length of Cut	Overall Length	Tool Number	Price Each
Standard Length					
3/8	3/8	3/4	2-1/2	CRA12-3	51.12
1/2	1/2	1-1/4	3-1/4	CRA16-4	69.00
5/8	5/8	1-5/8	3-3/4	CRA20-5	85.10
3/4	3/4	1-5/8	3-7/8	CRA24-6	110.17
7/8	3/4	2	4-1/8	CRA28-7	110.95
1	3/4	1-1/2	3-3/4	CRA32-6	151.80
1	1	2	4-1/2	CRA32-8	151.80
1-1/4	1-1/4	2	4-1/2	CRA40-10	186.88
1-1/2	1-1/4	2	4-1/2	CRA48-10	241.50
2	1-1/4	2	4-1/2	CRA64-10	391.40
Long Length					
1/2	1/2	2	4	CLA16-4	79.47
5/8	5/8	2-1/2	4-5/8	CLA20-5	109.66
3/4	3/4	3	5-1/4	CLA24-6	123.97
1	3/4	3	5-1/4	CLA32-6	166.45
1	1	3	5-1/4	CLA32-8	166.45
1	1	4	6-1/2	CLA32-8A	166.45
1-1/4	1-1/4	4	6-1/2	CLA40-10	227.70
1-1/2	1-1/4	4	6-1/2	CLA48-10	294.40
2	1-1/4	3	5-1/4	CLA64-10	444.65
2	1-1/4	4	6-1/2	CLA64-10A	476.65

● STUB LENGTH ROUGH PROFILE



Cutter Dia.	Shank Dia.	Length of Cut	Overall Length	Tool Number	No. of Flutes	Price Each
1/4	3/8	5/16	2-1/8	CRS8-3	4	36.00
5/16	3/8	7/16	2-3/16	CRS10-3	4	36.00
3/8	3/8	7/16	2-3/16	CRS12-3	4	36.00
1/2	1/2	5/8	2-5/8	CRS16-4	4	49.00
5/8	5/8	3/4	2-7/8	CRS20-5	4	59.50
3/4	3/4	3/4	3	CRS24-6	4	69.70
7/8	3/4	1-1/8	3-3/8	CRS28-6	5	89.00
1	3/4	1-1/8	3-3/8	CRS32-6	5	108.25
1	1	1-1/8	3-5/8	CRS32-8	5	108.25
1-1/4	3/4	1-1/8	3-1/2	CRS40-6	6	129.60
1-1/4	1-1/4	1-3/8	3-7/8	CRS40-10	6	129.60

► COBALT ROUGHING SETS



SET NO. CRS - 1

Mini Set

4 Piece Set

Contains 1 piece of each:

1/4, 5/16, 3/8, 1/2

Supplied in wood block

SET PRICE — 177.00

SET NO. CRS - 2

Bridgeport Set

4 Piece Set

Contains 1 piece of each:

1/2, 5/8, 3/4 x 3/4, 1 x 3/4

Supplied in wood block

SET PRICE — \$339.00



• COBALT ROUGHING END MILLS

SINGLE END

Shank type — Standard Length

ROUGH PROFILE

For deeper slotting or heavy side cuts.
For general purpose applications in steel.



FINE PROFILE

For shallow slotting or peripheral milling.
Recommended for use in exotic materials.

Shank Type					Rough Profile		Fine Profile	
Cutter Dia.	Shank Dia.	Length of Cut	Overall Length	No. of Flutes	Tool No.	Price Each	Tool No.	Price Each
1/4	3/8	5/8	2-7/16	4	CR8-3U	42.46	CRF8-3U	42.46
3/8	3/8	3/4	2-1/2	4	CR12-3U	44.45	CRF12-3U	44.45
1/2	1/2	1-1/4	3-1/4	4	CR16-4U	60.00	CRF16-4U	60.00
5/8	5/8	1-5/8	3-3/4	4	CR20-5U	74.00	CRF20-5U	74.00
3/4	3/4	1-5/8	3-3/4	4	CR24-6U	95.80	CRF24-6U	95.80
7/8	3/4	1-5/8	4-1/8	5	CR28-6U	96.50	CRF28-6U	96.50
1	3/4	2	4-1/2	5	CR32-6U	132.00	CRF32-6U	132.00
1	1	2	4-1/2	5	CR32-8U	132.00	CRF32-8U	132.00
1-1/4	3/4	2	4-1/4	6	CR40-6U	162.50	CRF40-6U	162.50
1-1/2	1-1/4	2	4-1/2	6	CR48-10U	210.00	CRF48-10U	210.00
2	1-1/4	2	4-1/2	8	CR64-10U	285.00	CRF64-10U	285.60

• Chipmaster COBALT ROUGHING END MILLS

BALL END



ROUGH PROFILE

Dia. of Cut	Shank Dia.	Length of Cut	Overall Length	No. of Flutes	Tool No.	Price Each	Dia. of Cut	Shank Dia.	Length of Cut	Overall Length	No. of Flutes	Tool No.	Price Each
1/4	3/8	5/8	2-7/16	4	CRB8-3	50.67	7/8	3/4	1-5/8	4-1/8	5	CRB28-6	118.50
5/16	3/8	3/4	2-1/2	4	CRB10-3	51.47	7/8	7/8	1-7/8	4-1/8	5	CRB28-7	118.50
3/8	3/8	3/4	2-1/2	4	CRB12-3	55.46	7/8	7/8	3-1/2	5-3/4	4	CLB28-7	157.00
7/16	3/8	1	2-11/16	4	CRB14-3	65.63	1	1	2	4-1/2	5	CRB32-8	156.00
1/2	1/2	1-1/4	3-1/4	4	CRB16-4	72.21	1	1	4	6-1/2	6	CLB32-8	169.00
1/2	1/2	2	4	4	CLB16-4	81.37	1-1/8	1	2	4-1/2	6	CRB36-8	181.90
9/16	1/2	1-3/8	3-3/8	4	CRB18-4	80.00	1-1/4	1-1/4	2	4-1/2	6	CRB40-10	204.50
5/8	5/8	1-5/8	3-3/4	4	CRB20-5	88.00	1-1/4	1-1/4	4	6-1/2	6	CLB40-10	240.00
5/8	5/8	2-1/2	4-5/8	4	CLB20-5	109.36	1-1/2	1-1/4	2	4-1/2	6	CRB48-10	272.00
3/4	3/4	1-5/8	3-3/4	4	CRB24-6	99.70	1-1/2	1-1/4	4	6-1/2	6	CLB48-10	318.00
3/4	3/4	3	5-1/4	4	CLB24-6	126.81							

Ball End Roughers also available in medium and extra long lengths. Please inquire.

• COBALT TiN/TiCN COATED ROUGHING END MILLS

ROUGH PROFILE

Dia. of Cut	Shank Dia.	Length of Cut	Overall Length	No. of Flutes	TiN Tool No.	TiN Price Each	TiCN Tool No.	TiCN Price Each
1/4	3/8	5/8	2-7/16	4	CRT8-3	49.90	CRTC8-3	51.00
5/16	3/8	3/4	2-1/2	4	CRT10-3	49.90	CRTC10-3	51.00
3/8	3/8	3/4	2-1/2	4	CRT12-3	52.50	CRTC12-3	53.50
7/16	3/8	1	2-11/16	4	CRT14-3	61.50	CRTC14-3	62.50
1/2	1/2	1-1/4	3-1/4	4	CRT16-4	68.00	CRTC16-4	69.00
9/16	1/2	1-3/8	3-3/8	4	CRT18-4	77.00	CRTC18-4	79.00
5/8	5/8	1-5/8	3-3/4	4	CRT20-5	86.00	CRTC20-5	89.90
3/4	5/8	1-5/8	3-3/4	4	CRT24-5	97.15	CRTC24-5	98.00
3/4	3/4	1-5/8	3-3/4	4	CRT24-6	97.15	CRTC24-6	98.00
7/8	3/4	1-5/8	4-1/8	5	CRT28-6	118.00	CRTC28-6	127.40
1	3/4	2	4-1/2	5	CRT32-6	146.50	CRTC32-6	156.80
1	1	2	4-1/2	5	CRT32-8	146.50	CRTC32-8	156.80
1-1/8	3/4	2	4-1/4	5	CRT36-6	179.50	CRTC36-6	192.00
1-1/8	1	2	4-1/2	6	CRT36-8	179.50	CRTC36-8	192.00
1-1/4	3/4	2	4-1/4	6	CRT40-6	201.10	CRTC40-6	212.20
1-1/4	1	2	4-1/2	5	CRT40-8	201.10	CRTC40-8	212.20
1-1/2	1-1/4	2	4-1/2	6	CRT48-10	235.50	CRTC48-10	249.00
2	1-1/4	2	4-1/2	8	CRT64-10	360.00	CRTC64-10	385.00

• SOLID CARBIDE ROUGHING END MILLS

SINGLE END



FOUR FLUTE

Size	Shank Diameter	Flute Length	Overall Length	Tool No.	Price Each
1/4	1/4	3/4	2-1/2	CRSC8-3	39.90
5/16	5/16	3/4	2-1/2	CRSC10-3	47.00
3/8	3/8	1	2-1/2	CRSC12-3	54.00
7/16	7/16	1	3	CRSC14-3	64.00
1/2	1/2	1-1/4	3	CRSC16-4	68.90
5/8	5/8	1-5/8	3-1/2	CRSC20-6	113.90
3/4	3/4	1-5/8	4	CRSC24-6	156.90
1	1	1-3/4	4	CRSC32-8	254.00

T-15 COBALT END MILLS

- For "difficult to machine" materials such as stainless steels, cast iron, abrasive plastics and bakelite.
- Greater abrasive resistance and high red hardness.
- Designed for use in high strength thermal resistant metals.

- For machining (30-50) Rockwell "C" hardness range steels.
- Higher surface speeds may be used.
- Expect significantly longer tool life.

SINGLE END

TWO FLUTE, REGULAR LENGTH



• LIST NO. T2031

Diameter of Cut	Shank Dia.	Length of Cut	Overall Length	Price Each
1/8	3/8	3/8	2-5/16	37.00
3/16	3/8	7/16	2-5/16	37.00
1/4	3/8	1/2	2-5/16	37.00
5/16	3/8	9/16	2-5/16	37.00
3/8	3/8	9/16	2-5/16	37.00
7/16	3/8	13/16	2-1/2	47.28
1/2	1/2	1	3	50.00
5/8	5/8	1-5/16	3-7/16	72.00
3/4	3/4	1-5/16	3-9/16	84.00
7/8	7/8	1-1/2	3-3/4	115.37
1	1	1-5/8	4-1/8	134.00
1-1/4	1-1/4	1-5/8	4-1/8	190.00
1-1/2	1-1/4	1-5/8	4-1/8	240.00
1-3/4	1-1/4	1-5/8	4-1/8	283.99
2	1-1/4	1-5/8	4-1/8	331.18

All multiple flute styles have center cutting teeth for plunge cutting.

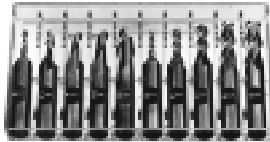

SET

SET NO. TC151
 10 Piece Set
 Contains 1 piece of each:
 Two and Four Flute
 1/8, 3/16, 1/4, 5/16, 3/8
SET PRICE — \$369.00

CENTER CUTTING

MULTI-FLUTE, REGULAR LENGTH



• LIST NO. T2005

Diameter of Cut	Shank Dia.	Length of Cut	Overall Length	No. of Flutes	Price Each
1/8	3/8	3/8	2-5/16	4	38.00
3/16	3/8	1/2	2-3/8	4	38.00
1/4	3/8	5/8	2-7/16	4	38.00
5/16	3/8	3/4	2-1/2	4	38.00
3/8	3/8	3/4	2-1/2	4	38.00
7/16	3/8	1	2-11/16	4	51.43
1/2	1/2	1-1/4	3-1/4	4	54.00
5/8	5/8	1-5/8	3-3/4	4	74.00
3/4	3/4	1-5/8	3-7/8	4	86.00
7/8	7/8	1-7/8	4-1/8	4	114.00
1	1	2	4-1/2	4	138.00
1-1/4	1-1/4	2	4-1/2	6	190.00
1-1/2	1-1/4	2	4-1/2	6	230.00
1-3/4	1-1/4	2	4-1/2	6	330.71
2	1-1/4	2	4-1/2	4	357.27
2	1-1/4	2	4-1/2	6	357.27
2	1-1/4	2	4-1/2	8	357.27

CENTER CUTTING

MULTI-FLUTE, LONG FLUTE LENGTH



• LIST NO. T2006

Diameter of Cut	Shank Diameter	Length of Cut	Overall Length	Number of Flutes	Price Each
1/4	3/8	1-1/4	3-1/16	4	45.00
5/16	3/8	1-3/8	3-1/8	4	45.00
3/8	3/8	1-1/2	3-1/4	4	45.00
1/2	1/2	2	4	4	58.00
5/8	5/8	2-1/2	4-5/8	4	80.00
3/4	3/4	3	5-1/4	4	94.00
1	1	4	6-1/2	4	164.00
1-1/4	1-1/4	4	6-1/2	6	254.00
1-1/2	1-1/4	4	6-1/2	6	355.81
2	1-1/4	4	6-1/2	6	474.57
2	1-1/4	4	6-1/2	8	474.57

CENTER CUTTING

MULTI-FLUTE, EXTRA LONG FLUTE LENGTH



• LIST NO. T2007

Diameter of Cut	Shank Diameter	Length of Cut	Overall Length	Number of Flutes	Price Each
1/4	3/8	1-3/4	3-9/16	4	56.00
5/16	3/8	2	3-3/4	4	56.00
3/8	3/8	2-1/2	4-1/4	4	56.00
1/2	1/2	3	5	4	74.00
5/8	5/8	4	6-1/8	4	100.00
3/4	3/4	4	6-1/4	4	110.00
1	1	6	8-1/2	4	220.00
1-1/2	1-1/4	6	8-1/2	6	519.25

BALL END

TWO FLUTE, REGULAR LENGTH



• LIST NO. T2091

Diameter of Cut	Shank Diameter	Length of Cut	Overall Length	Price Each
1/8	3/8	3/8	2-5/16	48.00
3/16	3/8	7/16	2-5/16	48.00
1/4	3/8	1/2	2-5/16	48.00
5/16	3/8	9/16	2-5/16	48.00
3/8	3/8	9/16	2-5/16	48.00
1/2	1/2	1	3	68.00
5/8	5/8	1-5/16	3-7/16	102.00
3/4	3/4	1-5/16	3-9/16	116.00
1	1	1-5/8	4-1/8	186.00
1-1/4	1-1/4	1-5/8	4-1/8	261.56
1-1/2	1-1/4	1-5/8	4-1/8	326.53

CENTER CUTTING

MULTI-FLUTE, REGULAR LENGTH



• LIST NO. T2092

Diameter of Cut	Shank Diameter	Length of Cut	Overall Length	Number of Flutes	Price Each
1/8	3/8	3/8	2-5/16	4	62.00
3/16	3/8	1/2	2-3/8	4	62.00
1/4	3/8	5/8	2-7/16	4	62.00
5/16	3/8	3/4	2-1/2	4	62.00
3/8	3/8	3/4	2-1/2	4	72.00
1/2	1/2	1-1/4	3-1/4	4	84.00
5/8	5/8	1-5/8	3-3/4	4	110.00
3/4	3/4	1-5/8	3-7/8	4	130.00
1	1	2	4-1/2	4	190.00
1-1/4	1-1/4	2	4-1/2	6	280.00
1-1/2	1-1/4	2	4-1/2	6	330.00

SOLID CARBIDE END MILLS



SINGLE END REGULAR LENGTH

- LIST NO. KS92 — TWO FLUTE
- LIST NO. KST92 — TiN TWO FLUTE
- LIST NO. KSTLN92 — TiAIN TWO FLUTE



- LIST NO. KS94 — FOUR FLUTE
- LIST NO. KST94 — TiN FOUR FLUTE
- LIST NO. KSTLN94 — TiAIN FOUR FLUTE

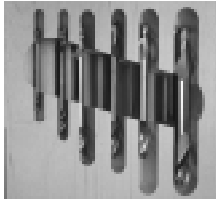

SET NO. KS92S
Solid Micrograin Carbide
2 Flute - Single End
6 Piece Set
Contains 1 piece of each:
1/8, 3/16, 1/4, 5/16, 3/8, 1/2
Supplied in wood case.
SET PRICE — \$161.25

Dia. of Cut	Shank Diameter	Flute Length	Overall Length	Two Flute or Four Flute Price Each		
				Solid Carbide KS92 KS94	TiN Coated KST92 KST94	TiAIN Coated KSTLN92 KSTLN94
1/64	1/8	1/32	1-1/2	19.50	22.50	24.50
1/32	1/8	5/64	1-1/2	14.75	18.20	20.00
3/64	1/8	7/64	1-1/2	14.75	18.20	20.00
1/16	1/8	3/16	1-1/2	12.10	16.00	19.00
5/64	1/8	3/16	1-1/2	13.00	17.00	20.00
3/32	1/8	9/32	1-1/2	12.10	16.00	19.00
7/64	1/8	3/8	1-1/2	13.00	17.00	20.00
1/8	1/8	1/2	1-1/2	12.10	16.00	19.00
9/64	3/16	1/2	2	17.05	20.00	21.50
5/32	3/16	1/2	2	16.65	19.80	21.80
11/64	3/16	5/8	2	17.05	20.40	22.00
3/16	3/16	5/8	2	17.05	20.40	22.00
13/64	1/4	5/8	2-1/2	20.90	29.50	31.00
7/32	1/4	5/8	2-1/2	20.90	29.50	34.00
15/64	1/4	3/4	2-1/2	22.55	31.40	33.50
1/4	1/4	3/4	2-1/2	21.95	31.00	33.00
17/64	5/16	3/4	2-1/2	26.80	39.00	42.00
9/32	5/16	3/4	2-1/2	25.20	38.50	41.50
19/64	5/16	13/16	2-1/2	26.80	39.00	42.00
5/16	5/16	13/16	2-1/2	24.75	37.70	40.00
21/64	3/8	7/8	2-1/2	35.20	45.50	48.50
11/32	3/8	7/8	2-1/2	33.00	44.20	49.00
23/64	3/8	7/8	2-1/2	35.20	45.50	50.00
3/8	3/8	7/8	2-1/2	32.00	44.65	49.00
13/32	7/16	1	2-3/4	32.00	44.65	49.00
7/16	7/16	1	2-3/4	46.00	59.00	72.00
15/32	1/2	1	3	59.00	69.90	82.00
1/2	1/2	1	3	53.40	65.70	82.00
9/16	9/16	1-1/8	3-1/2	90.60	109.40	125.00
5/8	5/8	1-1/4	3-1/2	101.35	125.00	130.00
11/16	3/4	1-1/2	4	149.60	185.00	190.00
3/4	3/4	1-1/2	4	149.60	185.00	190.00
7/8	7/8	1-1/2	4	259.10	279.60	300.00
1	1	1-1/2	4	265.00	299.77	325.00

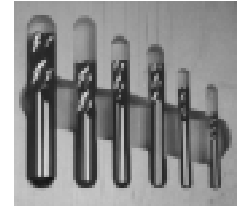

SET NO. KS94S
Solid Micrograin Carbide
4 Flute - Single End
6 Piece Set
Contains 1 piece of each:
1/8, 3/16, 1/4, 5/16, 3/8, 1/2
Supplied in wood case.
SET PRICE — \$161.25

LONG LENGTH

- LIST NO. KS92L — TWO FLUTE
- LIST NO. KS94L — FOUR FLUTE

Dia. of Cut	Shank Dia.	Flute Length	Two Flute or Four Flute Price Each	
			Overall Length	KS92L KS94L
1/8	1/8	3/4	2-1/4	19.90
3/16	3/16	3/4	2-1/4	23.95
1/4	1/4	1-1/8	3	32.00
5/16	5/16	1-1/8	3	35.70
3/8	3/8	1-1/8	3	45.00
7/16	7/16	2	4	69.50
1/2	1/2	2	4	85.00
5/8	5/8	2-1/4	5	175.00
3/4	3/4	2-1/4	5	230.80
1	1	2-1/4	5	399.00

EXTRA LONG LENGTH

- LIST NO. KS92XL — TWO FLUTE
- LIST NO. KS94XL — FOUR FLUTE

Dia. of Cut	Shank Dia.	Flute Length	Two Flute or Four Flute Price Each	
			Overall Length	KS92XL KS94XL
1/8	1/8	1	3	26.50
3/16	3/16	1-1/8	3	30.50
1/4	1/4	1-1/2	4	37.50
5/16	5/16	1-5/8	4	47.90
3/8	3/8	1-3/4	4	69.77
7/16	7/16	3	6	125.85
1/2	1/2	3	6	129.00
5/8	5/8	3	6	237.00
3/4	3/4	3	6	298.00
1	1	3	6	440.00

DOUBLE END

3/8" WELDON SHANKS

- LIST NO. KD82 — TWO FLUTE
- LIST NO. KD84 — FOUR FLUTE

CENTER CUTTING



Dia. of Cut	Shank Dia.	Flute Length	Two Flute or Four Flute Price Each	
			Overall Length	KD82 KD84
1/8	3/8	3/8	3-1/16	36.00
5/32	3/8	7/16	3-1/8	38.05
3/16	3/8	1/2	3-1/4	39.65
7/32	3/8	9/16	3-3/8	45.65
1/4	3/8	5/8	3-3/8	48.70

Dia. of Cut	Shank Dia.	Flute Length	Two Flute or Four Flute Price Each	
			Overall Length	KD82 KD84
5/16	3/8	3/4	3-1/2	58.50
11/32	3/8	3/4	3-1/2	63.50
3/8	3/8	3/4	3-1/2	63.50
7/16	1/2	7/8	4	99.50
1/2	1/2	1	4	101.00



MICROGRAIN

SOLID CARBIDE END MILLS

DOUBLE END

STUB LENGTH — CENTER CUTTING



- LIST NO. KD92 — TWO FLUTE
- LIST NO. KDT92 — TiN TWO FLUTE
- LIST NO. KDTLN92 — TiAIN TWO FLUTE

- LIST NO. KD94 — FOUR FLUTE
- LIST NO. KDT94 — TiN FOUR FLUTE
- LIST NO. KDTLN94 — TiAIN FOUR FLUTE

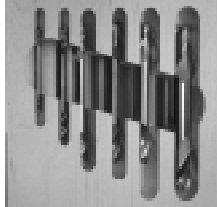

SET NO. KD92S

Solid Micrograin Carbide
2 Flute - Double End
6 Piece Set
Contains 1 piece of each:
1/8, 3/16, 1/4, 5/16, 3/8, 1/2
Supplied in wood case
SET PRICE — \$205.65

Dia. of Cut	Shank Dia.	Flute Length	Overall Length	Two or Four Flute Price Each		
				Solid Carbide KD92 KD94	TiN Coated KDT92 KDT94	TiAIN Coated KDTLN92 KDTLN94
1/32	1/8	1/16	1-1/2	17.00	21.50	22.50
3/64	1/8	3/32	1-1/2	16.10	20.55	21.50
1/16	1/8	1/8	1-1/2	14.30	19.66	21.50
5/64	1/8	1/8	1-1/2	16.10	20.55	22.50
3/32	1/8	3/16	1-1/2	14.30	19.66	22.50
7/64	1/8	3/16	1-1/2	16.10	20.55	22.50
1/8	1/8	1/4	1-1/2	13.45	18.40	24.70
9/64	3/16	5/16	2	23.70	29.00	30.00
5/32	3/16	5/16	2	19.00	25.70	26.90
11/64	3/16	5/16	2	23.70	29.00	30.00
3/16	3/16	3/8	2	20.20	26.48	27.70
13/64	1/4	1/2	2-1/2	30.12	42.68	43.50
7/32	1/4	1/2	2-1/2	25.00	37.40	38.90
1/4	1/4	1/2	2-1/2	25.00	37.40	38.90
9/32	5/16	1/2	2-1/2	32.50	48.60	49.95
5/16	5/16	1/2	2-1/2	34.30	48.60	49.95
3/8	3/8	9/16	2-1/2	35.90	51.43	58.00
7/16	7/16	5/8	2-3/4	51.75	71.30	78.80
1/2	1/2	5/8	3	62.30	81.50	88.00

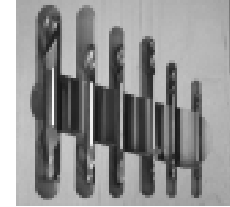

SET NO. KD94S

Solid Micrograin Carbide
4 Flute - Double End
6 Piece Set
Contains 1 piece of each:
1/8, 3/16, 1/4, 5/16, 3/8, 1/2
Supplied in wood case
SET PRICE — \$205.65

BALL END

CENTER CUTTING

SINGLE END



- LIST NO. KB92 — TWO FLUTE
- LIST NO. KBT92 — TiN TWO FLUTE
- LIST NO. KB94 — FOUR FLUTE
- LIST NO. KBT94 — TiN FOUR FLUTE

DOUBLE END — STUB LENGTH



- LIST NO. KB82 — TWO FLUTE
- LIST NO. KB84 — FOUR FLUTE

Dia. of Cut	Shank Dia.	Flute Length	Overall Length	Two or Four Flute Price Each	
				Solid Carbide KB92 KB94	TiN Coated KBT92 KBT94
1/64	1/8	1/32	1-1/2	22.50	24.50
1/32	1/8	5/64	1-1/2	18.95	19.90
3/64	1/8	9/64	1-1/2	18.95	19.90
1/16	1/8	3/16	1-1/2	14.50	15.50
5/64	1/8	1/4	1-1/2	15.60	16.70
3/32	1/8	3/8	1-1/2	14.50	15.50
7/64	1/8	3/8	1-1/2	15.60	16.70
1/8	1/8	1/2	1-1/2	14.50	15.50
9/64	3/16	1/2	2	22.00	23.50
5/32	3/16	9/16	2	20.00	21.50
11/64	3/16	9/16	2	22.00	23.50
3/16	3/16	5/8	2	20.70	22.50
13/64	1/4	5/8	2-1/2	28.00	30.00
7/32	1/4	5/8	2-1/2	26.10	28.00
1/4	1/4	3/4	2-1/2	26.30	28.00
9/32	5/16	3/4	2-1/2	28.50	33.00
5/16	5/16	13/16	2-1/2	29.60	34.00
11/32	3/8	7/8	2-1/2	40.50	45.00
3/8	3/8	7/8	2-1/2	37.60	42.00
7/16	7/16	1	2-3/4	55.25	60.00
1/2	1/2	1	3	64.10	69.00
9/16	9/16	1-1/8	3-1/2	108.10	118.00
5/8	5/8	1-1/4	3-1/2	149.00	159.00
11/16	3/4	1-3/8	4	179.60	189.00
3/4	3/4	1-1/2	4	179.60	189.00
7/8	7/8	1-1/2	4	297.00	326.00
1	1	1-1/2	4	310.00	329.00

Dia. of Cut	Shank Dia.	Flute Length	Overall Length	Two or Four Flute Price Each	
				KB82	KB84
1/32	1/8	1/16	1-1/2	23.00	
3/64	1/8	3/32	1-1/2	23.00	
1/16	1/8	1/8	1-1/2	17.20	
5/64	1/8	1/8	1-1/2	17.20	
3/32	1/8	3/16	1-1/2	17.20	
7/64	1/8	3/16	1-1/2	17.20	
1/8	1/8	1/4	1-1/2	16.00	
9/64	3/16	5/16	2	24.50	
5/32	3/16	5/16	2	22.80	
11/64	3/16	5/16	2	28.30	
3/16	3/16	3/8	2	24.25	
7/32	1/4	1/2	2-1/2	32.00	
1/4	1/4	1/2	2-1/2	38.10	
9/32	5/16	1/2	2-1/2	41.10	
5/16	5/16	1/2	2-1/2	43.00	
3/8	3/8	9/16	2-1/2	45.00	
7/16	7/16	5/8	2-3/4	62.25	
1/2	1/2	5/8	3	79.75	

SET NO. KB82S

Solid Micrograin Carbide
2 Flute - Ball End
6 Piece Set
Contains 1 piece of each:
1/8, 3/16, 1/4, 5/16, 3/8, 1/2
Supplied in wood case
SET PRICE — \$260.60

SET NO. KB84S

Solid Micrograin Carbide
Four Flute - Ball End
6 Piece Set
Contains 1 piece of each:
1/8, 3/16, 1/4, 5/16, 3/8, 1/2
Supplied in wood case
SET PRICE — \$260.60



MICROGRAIN

SOLID CARBIDE METRIC END MILLS SINGLE END



- LIST NO. KSM92 — TWO FLUTE
- LIST NO. KSM94 — FOUR FLUTE



Dia. of Cut mm	Shank Dia. mm	Flute Length mm	Two or Four Flute Price Each	
			Overall Length mm	KSM92 KSM94
1.0	3	4	38	13.40
1.5	3	4.5	38	13.40
2.0	3	6.3	38	13.40
2.5	3	9.5	38	13.40
3.0	3	12	38	13.40
3.5	4	12	50	17.90
4.0	4	14	50	17.90
4.5	5	16	50	19.75
5.0	5	16	50	19.75
6.0	6	19	50	25.80
7.0	8	19	63	33.00

Dia. of Cut mm	Shank Dia. mm	Flute Length mm	Two or Four Flute Price Each	
			Overall Length mm	KSM92 KSM94
8.0	8	20	63	36.40
9.0	10	22	75	49.90
10.0	10	22	75	49.90
11.0	11	25	75	57.00
12.0	12	25	75	68.90
14.0	14	32	89	93.60
16.0	16	32	89	107.90
18.0	18	38	100	152.45
20.0	20	38	100	183.90
22.0	25	38	100	266.70
25.0	25	38	100	284.00

MICROGRAIN

SOLID CARBIDE END MILLS SINGLE END

1/8" SHANK — 1-1/2" OVERALL LENGTH

- LIST NO. KSD92 — TWO FLUTE
- LIST NO. KSD94 — FOUR FLUTE



DECIMAL SIZES

Dia. of Cut	Two or Four Flute Price Each	
	Flute Length	KSD92 KSD94
.010	.030	24.50
.015	.045	19.50
.020	.060	18.90
.025	.075	17.75
.030	.090	17.75
.035	.105	17.75
.040	.120	17.75
.045	.135	14.95

Dia. of Cut	Two or Four Flute Price Each	
	Flute Length	KSD92 KSD94
.050	.150	14.95
.055	.165	14.95
.060	.180	14.95
.065	.195	14.95
.070	.210	14.95
.075	.225	14.95
.080	.240	14.95
.085	.255	14.95

Dia. of Cut	Two or Four Flute Price Each	
	Flute Length	KSD92 KSD94
.090	.270	14.95
.095	.285	14.95
.100	.300	14.95
.105	.315	14.95
.110	.330	14.95
.115	.345	14.95
.120	.360	14.95

PREMIUM MICROGRAIN

SIX FLUTE SOLID CARBIDE END MILLS

- LIST NO. KSD96



The six flute design helps reduce chip load and improve the work piece finish.

Dia. of Cut	Shank Dia.	Flute Length	Overall Length	Price Each
1/8	1/8	3/8	1-1/2	20.75
5/32	3/16	1/2	2	28.70
3/16	3/16	9/16	2	29.95
1/4	1/4	3/4	2-1/2	38.90
5/16	5/16	13/16	2-1/2	43.50
3/8	3/8	7/8	2-1/2	55.20
7/16	7/16	1	2-3/4	79.95
1/2	1/2	1	3	92.00

MICROGRAIN

THREE FLUTE SOLID CARBIDE END MILLS

- LIST NO. KS9345 — 45° High Helix
- LIST NO. KS9360 — 60° High Helix



Three cutting edges to reduce vibration and produce better finishes. High shear design is engineered for slotting, plunging and peripheral milling applications.

Dia. of Cut	Shank Dia.	Flute Length	45° or 60° Price Each	
			Overall Length	KS9345 KS9360
1/8	1/8	1/2	1-1/2	25.40
3/16	3/16	5/8	2	27.50
1/4	1/4	3/4	2-1/2	29.00
5/16	5/16	13/16	2-1/2	37.00
3/8	3/8	7/8	2-1/2	54.80
7/16	7/16	1	3	78.40
1/2	1/2	1	3	84.50
5/8	5/8	1-1/4	3-1/2	136.00
3/4	3/4	1-1/2	4	199.00
1	1	1-1/2	4	375.00

CORNER ROUNDING END MILLS

- LIST NO. 282 — HIGH SPEED
- LIST NO. 282C — COBALT

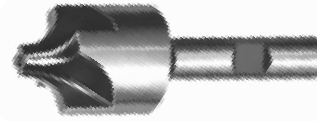

These End Mills are used for rounding corners and adapting many screw machine applications as end forming tools to form a specific radius. They can be resharpened many times without changing the contour.

Radius	Shank Diameter	Cutter Diameter	Overall Length	List No. 282	List No. 282C
1/32	3/8	3/8	2-1/2	53.80	—
1/16	3/8	7/16	2-1/2	53.80	91.50
3/32	3/8	1/2	2-1/2	54.45	92.56
1/8	3/8	5/8	3	59.90	101.85
1/8	1/2	5/8	3	59.90	101.85
5/32	1/2	3/4	3	64.35	109.40
3/16	1/2	7/8	3-1/8	68.10	115.75
3/16	3/4	7/8	3-1/8	68.10	115.75
1/4	1/2	1	3-1/8	73.20	124.50
1/4	3/4	1	3-1/4	73.20	124.50
9/32	1/2	1-1/8	3-1/4	85.00	—
5/16	1/2	1-1/8	3-1/4	89.44	152.90
5/16	3/4	1-1/8	3-1/4	89.94	152.90
5/16	7/8	1-1/8	3-1/2	89.94	152.90
3/8	1/2	1-1/4	3-1/2	102.00	173.40
3/8	3/4	1-1/4	3-1/2	102.00	173.40

Radius	Shank Diameter	Cutter Diameter	Overall Length	List No. 282	List No. 282C
3/8	7/8	1-1/4	3-1/4	102.00	173.40
7/16	3/4	1-3/8	3-3/4	112.31	190.90
7/16	1	1-3/8	4	112.31	190.90
15/32	3/4	1-3/8	3-3/4	139.50	—
1/2	3/4	1-1/2	3-7/8	139.50	237.10
1/2	1	1-1/2	4-1/8	139.50	237.10
9/16	3/4	1-15/16	4	167.10	—
5/8	3/4	1-15/16	4	167.10	284.00
5/8	1	1-15/16	4	167.10	—
21/32	3/4	1-15/16	4	197.90	—
3/4	3/4	2-1/4	4-1/8	197.90	337.40
3/4	1	2-1/4	4-5/16	197.90	—
13/16	1	2-1/4	4-5/16	234.00	—
1	3/4	2-1/4	4-5/16	293.00	—
1	1	2-5/8	4-1/2	315.00	—
1	1	2-5/8	4-3/4	315.00	—

Arbor type corner rounding cutters available. Please inquire.

HIGH SPEED STEEL

SETS

SET NO. 282A

8 Piece Set
Contains 1 piece of each:
1/16, 3/32(x3/8 Shk); 1/8, 5/32, 3/16,
1/4, 5/16, 3/8 (x1/2 Shk)
Supplied in wood block.
SET PRICE — \$559.00



SET NO. 282B

4 Piece Set
Contains 1 piece of each:
1/2, 9/16, 5/8, 3/4 (x3/4 Shk)
Supplied in wood block.
SET PRICE — \$670.90

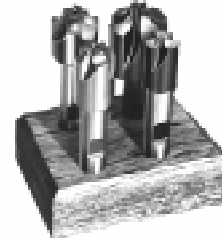

HIGH SPEED STEEL

SINGLE-END END MILLS FOR ALUMINUM

TWO-FLUTE — HIGH HELIX

- LIST NO. 235 — REGULAR LENGTH
- LIST NO. 236 — LONG FLUTE LENGTH
- LIST NO. 237 — EXTRA LONG FLUTE LENGTH



These Endmills are designed to cut aluminum and non-ferrous materials at high material removal rates, therefore, providing better work piece tolerances, surface finishes and cuts without vibration, chatter or scarring.

Diameter of Cut	Shank Diameter	Regular Length			Long Flute Length			Extra Long Flute Length		
		Length of Cut	Overall Length	List No. 235	Length of Cut	Overall Length	List No. 236	Length of Cut	Overall Length	List No. 237
1/4	3/8	5/8	2-1/2	17.25	1-1/4	3-1/8	20.00	1-3/4	3-1/2	22.55
5/16	3/8	3/4	2-1/2	17.25	1-3/8	3-1/8	20.00	2	3-3/4	23.20
3/8	3/8	3/4	2-1/2	17.25	1-1/2	3-1/4	20.00	2-1/2	4-1/4	24.35
7/16	1/2*	1	2-11/16	21.05	1-3/4	3-1/4	26.80	2-3/4	4-3/4	32.50
1/2	1/2	1-1/4	3-1/4	23.40	2	4	27.25	3	5	32.50
5/8	5/8	1-5/8	3-3/4	32.68	2-1/2	4-5/8	36.60	4	6-1/8	45.05
3/4	3/4	1-5/8	3-7/8	34.05	3	5-1/4	47.30	4	6-1/4	64.00
7/8	7/8	1-7/8	4-1/8	49.30	3-1/2	5-3/4	63.00	5	7-1/4	73.85
1	1	2	4-1/2	56.85	4	6-1/2	82.50	6	8-1/2	100.40
1-1/4	1-1/4	2	4-1/2	87.20	4	6-1/2	117.91	6	8-1/2	147.89
1-1/2	1-1/4	2	4-1/2	108.35	4	6-1/2	149.49	6	8-1/2	209.81
1-3/4	1-1/4	2	4-1/2	143.37	4	6-1/2	208.00	—	—	—
2	1-1/4	2	4-1/2	171.53	4	6-1/2	241.02	—	—	—

* 3/8 Shank on List No. 235

HIGH SPEED SHELL END MILLS

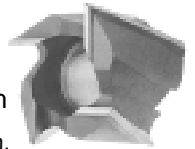

- LIST NO. 285 — RIGHT HAND
- LIST NO. 285L — LEFT HAND



For facing and slab milling in all types of materials.

Dia. of Cut	Hole Size	Length of Cut	No. of Flutes	Price Each	
				R.H. List No. 285	L.H. List No. 285L
1-1/4	1/2	1	8	55.40	72.00
1-1/2	1/2	1-1/8	8	60.20	74.25
1-3/4	3/4	1-1/4	8	73.30	94.80
2	3/4	1-3/8	10	82.00	112.75
2-1/4	1	1-1/2	10	91.50	128.95
2-1/2	1	1-5/8	10	108.25	138.00
2-3/4	1	1-5/8	10	135.80	180.90
3	1-1/4	1-3/4	12	154.90	213.00
3-1/2	1-1/4	1-7/8	12	211.25	285.40
4	1-1/2	2-1/4	14	259.60	358.50
4-1/2	1-1/2	2-1/4	14	338.80	466.00
5	1-1/2	2-1/4	16	402.25	600.00
5-1/2	2	2-1/4	16	570.80	798.00
6	2	2-1/4	16	592.25	875.00

- LIST NO. 286 — For Aluminum

For face and slab milling in aluminum.

Dia. of Cut	Hole Size	Length of Cut	No. of Flutes	Price Each
1-1/4	1/2	1	8	59.00
1-1/2	1/2	1-1/8	8	68.00
1-3/4	3/4	1-1/4	8	75.00
2	3/4	1-3/8	10	87.00
2-1/4	1	1-1/2	10	98.00
2-1/2	1	1-5/8	10	120.00
2-3/4	1	1-5/8	10	144.00
3	1-1/4	1-3/4	12	168.00
3-1/2	1-1/4	1-7/8	12	240.00
4	1-1/2	2-1/4	14	270.00
4-1/2	1-1/2	2-1/4	14	350.00
5	1-1/2	2-1/4	16	488.00
5-1/2	2	2-1/4	16	640.00
6	2	2-1/4	16	738.00

COBALT ROUGHING SHELL END MILLS

COBALT SHELL END MILLS

- LIST NO. 285C

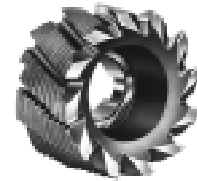

Dia. of Cut	Hole Size	Length of Cut	No. of Flutes	Price Each
1-1/4	1/2	1	8	77.50
1-1/2	1/2	1-1/8	8	79.50
1-3/4	3/4	1-1/4	8	105.85
2	3/4	1-3/8	10	118.90
2-1/4	1	1-1/2	10	133.40
2-1/2	1	1-5/8	10	156.60
2-3/4	1	1-5/8	10	197.00
3	1-1/4	1-3/4	12	224.75
3-1/2	1-1/4	1-7/8	12	305.95
4	1-1/2	2-1/4	14	377.00
4-1/2	1-1/2	2-1/4	14	491.55
5	1-1/2	2-1/4	16	625.00
5-1/2	2	2-1/4	16	825.00
6	2	2-1/4	16	998.00

For deep slotting or heavy side cuts. Recommended for general purpose applications in steel.

Dia. of Cut	Hole Size	Length of Cut	No. of Flutes	Tool Number	Price Each
2	3/4	2	7	CS64-16	162.00
2-1/4	1	2	8	CS72-16	190.00
2-1/2	1	2	8	CS80-16	253.00
2-3/4	1	2	8	CS88-16	260.00
3	1-1/4	2	8	CS96-16	294.00
3-1/2	1-1/4	2	9	CS112-16	390.00
4	1-1/2	2-1/4	10	CS128-18	481.00
4-1/2	1-1/2	2-1/4	12	CS144-18	598.00
5	1-1/2	2-1/4	12	CS160-18	760.00
5-1/2	2	2-1/4	14	CS176-18	947.00
6	2	2-1/4	14	CS192-18	1065.00

HIGH SPEED STEEL

PLAIN METAL SLITTING SAWS

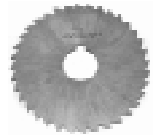

- LIST NO. 738

For general purpose slitting or cutting-off operations.

Diameter	Width of Face	Hole Size	Price Each
1-3/4	1/32	1/2	19.90
1-3/4	1/8	1/2	19.90
1-3/4	1/16	1/2	19.90
2	1/32	1/2	19.90
2	1/16	1/2	22.00
2	3/32	1/2	24.50
2	1/8	1/2	25.90
2	5/32	1/2	25.90
2-1/2	1/32	7/8	28.40
2-1/2	3/64	7/8	28.40
2-1/2	1/16	7/8	28.40
2-1/2	5/64	1	28.40
2-1/2	3/32	7/8	28.40
2-1/2	3/32	1	28.40
2-1/2	7/64	1	28.40
2-1/2	1/8	7/8	31.00
2-1/2	3/16	7/8	31.00
2-1/2	3/16	1	31.00
3	1/32	1	32.75
3	3/64	1	32.75

Diameter	Width of Face	Hole Size	Price Each
3	1/16	1	34.00
3	3/32	1	34.00
3	7/64	1	34.00
3	1/8	1	35.00
3	9/64	1	35.00
3	5/32	1	36.95
3	3/16	1	36.95
3	7/32	1	38.95
4	1/32	1	45.75
4	3/64	1	46.50
4	1/16	1	47.15
4	3/32	1	49.80
4	7/64	1	49.80
4	1/8	1	52.60
4	9/64	1	54.60
4	5/32	1	54.60
4	3/16	1	57.70
5	3/32	1	69.50
5	7/64	1	75.50
5	1/8	1-1/4	75.50

Diameter	Face Width	Hole Size	Price Each
5	1/8	1	75.50
5	5/32	1	78.25
5	3/16	1	78.25
5	3/16	1-1/4	78.25
5	7/32	1	78.25
5	1/4	1	79.90
6	1/16	1	79.90
6	1/16	1-1/4	79.90
6	3/32	1	91.50
6	3/32	1-1/4	91.50
6	1/8	1	94.35
6	1/8	1-1/4	94.35
6	3/16	1	112.50
6	3/16	1-1/4	112.50
8	1/8	1	195.30
8	1/8	1-1/4	195.30
8	3/16	1-1/4	233.00
10	1/8	1-1/4	306.00
10	3/16	1-1/4	350.00
10	1/4	1-1/4	350.00

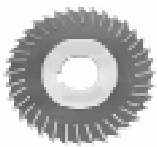

HIGH SPEED STEEL

SIDE CHIP CLEARANCE METAL SLITTING SAWS

STRAIGHT TEETH

● LIST NO. 739S

The side chip clearance allows cut-off or slotting operations of considerable depth.

Diameter	Face Width	Hole Size	Price Each
2	3/32	5/8	34.25
2	1/8	5/8	34.25
2	5/32	5/8	34.25
2-1/2	1/16	7/8	43.72
2-1/2	3/32	7/8	43.72
2-1/2	1/8	7/8	43.72
2-1/2	1/8	1	43.72
3	1/16	1	50.44
3	5/64	1	50.44
3	3/32	1	50.44
3	7/64	1	50.44
3	1/8	1	50.44
3	9/64	1	50.44
3	5/32	1	50.44
3	11/64	1	50.44
3	3/16	1	50.44
3	1/4	1	50.44
4	1/16	1	67.16
4	5/64	1	67.16
4	3/32	1	67.16
4	3/32	1-1/4	67.16
4	7/64	1	67.16
4	1/8	1	67.16
4	1/8	1-1/4	67.16
4	5/32	1	70.08
4	11/64	1	70.08
4	3/16	1	73.00
4	3/16	1-1/4	73.00
4	7/32	1	73.00
4	1/4	1	73.00
5	1/16	1	86.88

Diameter	Face Width	Hole Size	Price Each
5	1/16	1-1/4	86.88
5	3/32	1	89.20
5	3/32	1-1/4	89.20
5	1/8	1	91.46
5	1/8	1-1/4	91.46
5	5/32	1	94.38
5	5/32	1-1/4	94.38
5	11/64	1	98.42
5	3/16	1	98.42
5	3/16	1-1/4	98.42
6	1/16	1	149.75
6	1/16	1-1/4	149.75
6	3/32	1	112.34
6	3/32	1-1/4	112.34
6	1/8	1	117.00
6	1/8	1-1/4	117.00
6	5/32	1	130.84
6	5/32	1-1/4	130.84
6	3/16	1	130.84
6	3/16	1-1/4	130.84
8	1/8	1	237.10
8	1/8	1-1/4	237.10
8	3/16	1-1/4	256.36
10	1/8	1-1/4	456.00
10	3/16	1-1/4	456.00
10	1/4	1-1/4	456.00
12	1/8	1-1/4	725.00
12	1/8	1-1/2	725.00
12	3/16	1-1/4	725.00
12	3/16	1-1/2	725.00
12	1/4	1-1/2	725.00

HIGH SPEED STEEL

SIDE CHIP CLEARANCE METAL SLITTING SAWS

STAGGERED TEETH

● LIST NO. 739ST

For making deeper cuts with coarser feeds in heavy duty slotting operations.

Diameter	Face Width	Hole Size	Price Each
3	1/16	1	59.50
3	3/32	1	59.50
3	7/64	1	59.50
3	1/8	1	59.50
3	9/64	1	59.50
3	5/32	1	59.50
3	11/64	1	59.50
3	3/16	1	60.78
3	1/4	1	62.98
4	3/32	1	79.90
4	3/32	1-1/4	79.90
4	7/64	1	79.90
4	7/64	1-1/4	79.90
4	1/8	1	79.90
4	1/8	1-1/4	79.90
4	9/64	1	84.00
4	5/32	1	84.00
4	5/32	1-1/4	84.00
4	11/64	1	84.00
4	3/16	1	84.00
4	7/32	1	90.00
4	1/4	1	90.00
4	1/4	1-1/4	90.00
5	1/8	1	98.78

Diameter	Face Width	Hole Size	Price Each
5	1/8	1-1/4	98.78
5	5/32	1	103.39
5	3/16	1	109.80
5	3/16	1-1/4	109.80
5	7/32	1	114.72
5	1/4	1	114.72
6	1/8	1	135.00
6	1/8	1-1/4	135.00
6	5/32	1	139.40
6	5/32	1-1/4	139.40
6	3/16	1	151.04
6	3/16	1-1/4	151.04
6	1/4	1	154.56
6	1/4	1-1/4	154.56
8	3/16	1-1/4	283.20
8	1/4	1-1/4	291.20
10	3/16	1-1/4	502.40
10	1/4	1-1/4	468.80
12	1/8	1-1/4	802.40
12	1/8	1-1/2	802.40
12	3/16	1-1/4	802.40
12	3/16	1-1/2	802.40
12	1/4	1-1/2	802.40
12	5/16	1-1/2	895.78



SIDE MILLING CUTTERS

STRAIGHT TEETH

For slotting and light duty side milling. These cutters can be ganged or used as straddle mills.

● LIST NO. 740

Cutter Dia.	Face Width	Hole Size	Price Each
2	3/16	1/2	41.75
2	3/16	5/8	41.75
2	1/4	1/2	41.75
2	1/4	5/8	37.89
2	3/8	1/2	41.75
2	3/8	5/8	41.75
2-1/2	1/4	7/8	50.95
2-1/2	5/16	7/8	52.11
2-1/2	3/8	7/8	56.82
2-1/2	3/8	1	56.82
2-1/2	1/2	7/8	57.85
2-1/2	1/2	1	57.85
2-1/2	5/8	1	67.00
3	3/16	1	49.99
3	3/16	1-1/4	50.50
3	7/32	1	54.09
3	7/32	1-1/4	52.20
3	1/4	1	58.75
3	1/4	1-1/4	58.75
3	9/32	1	60.55
3	9/32	1-1/4	60.55
3	5/16	1	61.79
3	5/16	1-1/4	61.79
3	3/8	1	65.65
3	3/8	1-1/4	65.65
3	13/32	1	67.50
3	13/32	1-1/4	67.50
3	7/16	1	69.60
3	7/16	1-1/4	69.60
3	1/2	1	70.55
3	1/2	1-1/4	70.55
3	9/16	1	72.10
3	9/16	1-1/4	72.10
3	5/8	1	74.25
3	5/8	1-1/4	74.25
3	11/16	1	78.50
3	11/16	1-1/4	78.50
3	3/4	1	80.15
3	3/4	1-1/4	80.15
3	13/16	1	95.82
3	13/16	1-1/4	95.82
3	7/8	1	115.40
3	7/8	1-1/4	115.40
3	15/16	1	120.75
3	15/16	1-1/4	120.75
3	1	1	127.10
3	1	1-1/4	127.10
3-1/2	3/16	1	69.00
3-1/2	1/4	1	69.22
3-1/2	5/16	1-1/4	76.00
3-1/2	3/8	1	79.60
3-1/2	7/16	1-1/4	80.45
3-1/2	1/2	1	85.00
3-1/2	1/2	1-1/4	85.00
3-1/2	5/8	1	92.80

Cutter Dia.	Face Width	Hole Size	Price Each
4	3/16	1	72.50
4	3/16	1-1/4	72.50
4	7/32	1	75.80
4	7/32	1-1/4	75.80
4	1/4	1	79.50
4	1/4	1-1/4	79.50
4	9/32	1	80.00
4	9/32	1-1/4	80.00
4	5/16	1	80.15
4	5/16	1-1/4	80.15
4	11/32	1	86.12
4	11/32	1-1/4	86.12
4	3/8	1	91.10
4	3/8	1-1/4	91.10
4	13/32	1	91.10
4	13/32	1-1/4	91.10
4	7/16	1	91.95
4	7/16	1-1/4	91.95
4	1/2	1	101.45
4	1/2	1-1/4	101.45
4	9/16	1	101.89
4	9/16	1-1/4	101.89
4	5/8	1	113.20
4	5/8	1-1/4	113.20
4	11/16	1	110.10
4	11/16	1-1/4	110.10
4	3/4	1	120.11
4	3/4	1-1/4	120.11
4	13/16	1	122.83
4	13/16	1-1/4	122.83
4	7/8	1	132.93
4	7/8	1-1/4	132.93
4	15/16	1	138.60
4	15/16	1-1/4	138.60
4	1	1	155.80
4	1	1-1/4	155.80
4-1/2	3/8	1-1/4	129.00
4-1/2	7/16	1-1/4	129.00
4-1/2	1/2	1-1/4	135.00
5	1/4	1	115.00
5	1/4	1-1/4	115.00
5	9/32	1	120.00
5	9/32	1-1/4	120.00
5	5/16	1	122.81
5	5/16	1-1/4	122.81
5	11/32	1	124.85
5	11/32	1-1/4	124.85
5	3/8	1	135.09
5	3/8	1-1/4	135.09
5	13/32	1	139.12
5	13/32	1-1/4	139.12
5	7/16	1	142.73
5	7/16	1-1/4	142.73
5	1/2	1	142.73
5	1/2	1-1/4	142.73

Cutter Dia.	Face Width	Hole Size	Price Each
5	9/16	1	154.00
5	9/16	1-1/4	154.00
5	5/8	1	158.00
5	5/8	1-1/4	158.00
5	11/16	1	170.00
5	11/16	1-1/4	170.00
5	3/4	1	171.39
5	3/4	1-1/4	171.39
5	13/16	1	180.50
5	13/16	1-1/4	180.50
5	7/8	1	190.89
5	7/8	1-1/4	190.89
5	15/16	1	195.00
5	15/16	1-1/4	195.00
5	1	1	202.89
5	1	1-1/4	202.89
6	1/4	1	159.00
6	1/4	1-1/4	159.00
6	9/32	1-1/4	165.00
6	5/16	1	165.00
6	5/16	1-1/4	165.00
6	11/32	1-1/4	169.00
6	3/8	1	169.00
6	3/8	1-1/4	169.00
6	13/32	1-1/4	170.29
6	7/16	1	170.29
6	7/16	1-1/4	170.29
6	1/2	1	178.42
6	1/2	1-1/4	178.42
6	9/16	1	185.00
6	9/16	1-1/4	185.00
6	5/8	1	194.70
6	5/8	1-1/4	194.70
6	11/16	1	199.40
6	11/16	1-1/4	199.40
6	3/4	1	228.55
6	3/4	1-1/4	228.55
6	13/16	1	230.95
6	13/16	1-1/4	230.95
6	7/8	1	235.79
6	7/8	1-1/4	235.79
6	15/16	1	242.55
6	15/16	1-1/4	242.55
6	1	1	270.50
6	1	1-1/4	270.50
7	5/8	1-1/4	323.70
7	3/4	1-1/4	347.45
7	1	1-1/4	424.70
8	5/16	1-1/4	437.50
8	3/8	1-1/4	457.10
8	1/2	1-1/4	485.00
8	3/4	1-1/4	540.00
8	1	1-1/4	669.00
8	1	1-1/2	669.00



SIDE MILLING CUTTERS STAGGERED TEETH

For deep slotting and heavy duty side milling. The shear cutting action eliminates the side thrust.

● LIST NO. 744

Cutter Dia.	Face Width	Hole Size	Price Each
2-1/2	1/4	7/8	60.15
2-1/2	5/16	7/8	63.60
2-1/2	3/8	7/8	69.93
2-1/2	7/16	7/8	71.88
2-1/2	1/2	7/8	73.88
3	3/16	1	65.65
3	3/16	1-1/4	65.65
3	1/4	1	72.45
3	1/4	1-1/4	72.45
3	9/32	1	75.50
3	5/16	1	77.30
3	5/16	1-1/4	77.30
3	5/32	1	79.86
3	11/32	1	79.86
3	3/8	1	79.86
3	3/8	1-1/4	81.20
3	7/16	1	81.20
3	7/16	1-1/4	84.60
3	1/2	1	84.60
3	1/2	1-1/4	84.80
3	9/16	1	84.80
3	9/16	1-1/4	89.00
3	5/8	1	89.00
3	5/8	1-1/4	89.00
3	11/16	1	89.00
3	11/16	1-1/4	94.00
3	3/4	1	105.78
3	3/4	1-1/4	105.78
3	13/16	1	109.50
3	13/16	1-1/4	109.50
3	7/8	1	112.00
3	7/8	1-1/4	112.00
3	15/16	1	130.00
3	15/16	1-1/4	130.00
3	1	1	135.10
3	1	1-1/4	135.10
3-1/2	1/4	1	95.00
3-1/2	5/16	1	105.27
3-1/2	3/8	1	110.00
3-1/2	1/2	1	120.00
3-1/2	5/8	1	129.75
3-1/2	13/16	1	129.75
4	3/16	1	92.50
4	3/16	1-1/4	92.50
4	7/32	1	96.00
4	7/32	1-1/4	96.00
4	1/4	1	105.25
4	1/4	1-1/4	105.25
4	9/32	1	109.60
4	9/32	1-1/4	109.60
4	5/16	1	112.00
4	5/16	1-1/4	112.00
4	11/32	1	115.00
4	11/32	1-1/4	115.00
4	3/8	1	117.29
4	3/8	1-1/4	117.29
4	13/32	1-1/4	120.95
4	7/16	1	120.95
4	7/16	1-1/4	122.39
4	1/2	1	124.70
4	1/2	1-1/4	124.70
4	9/16	1	129.71
4	9/16	1-1/4	129.71
4	5/8	1	144.58

Cutter Dia.	Face Width	Hole Size	Price Each
4	5/8	1-1/4	144.58
4	11/16	1	149.00
4	11/16	1-1/4	149.00
4	3/4	1	151.55
4	3/4	1-1/4	151.55
4	13/16	1	160.85
4	13/16	1-1/4	160.85
4	7/8	1	160.85
4	7/8	1-1/4	160.85
4	15/16	1	178.49
4	15/16	1-1/4	178.49
4	1	1	185.72
4	1	1-1/4	182.72
4	1-1/8	1-1/4	202.00
4	1-3/16	1-1/4	219.39
4	1-1/4	1-1/4	219.39
4	1-1/2	1-1/4	295.00
4-1/2	1/2	1	165.60
4-1/2	1/2	1-1/4	165.60
5	1/4	1	149.50
5	1/4	1-1/4	149.50
5	5/16	1	153.75
5	5/16	1-1/4	153.75
5	3/8	1	159.70
5	3/8	1-1/4	159.70
5	7/16	1	165.09
5	7/16	1-1/4	165.09
5	1/2	1	168.80
5	1/2	1-1/4	168.80
5	9/16	1	176.00
5	9/16	1-1/4	176.00
5	5/8	1	188.83
5	5/8	1-1/4	188.83
5	11/16	1	206.35
5	11/16	1-1/4	206.35
5	3/4	1	206.35
5	3/4	1-1/4	206.35
5	13/16	1	225.15
5	13/16	1-1/4	225.15
5	7/8	1	225.15
5	7/8	1-1/4	225.15
5	15/16	1-1/4	250.09
5	1	1-1/4	255.00
6	1/4	1	194.99
6	1/4	1-1/4	194.99
6	9/32	1	194.99
6	9/32	1-1/4	194.99
6	5/16	1	194.99
6	5/16	1-1/4	194.99
6	3/8	1	194.99
6	3/8	1-1/4	194.99
6	7/16	1	209.95
6	7/16	1-1/4	209.95
6	1/2	1	222.98
6	1/2	1-1/4	222.98
6	9/16	1	237.97
6	9/16	1-1/4	237.97
6	5/8	1	252.98
6	5/8	1-1/4	252.98
6	11/16	1	270.00
6	11/16	1-1/4	270.00
6	3/4	1	270.00
6	3/4	1-1/4	270.00

Cutter Dia.	Face Width	Hole Size	Price Each
6	13/16	1	270.00
6	13/16	1-1/4	320.00
6	7/8	1	320.00
6	7/8	1-1/4	320.00
6	15/16	1	339.00
6	15/16	1-1/4	339.00
6	1	1-1/4	339.00
6	1-1/8	1-1/4	369.00
6	1-3/16	1-1/4	369.00
6	1-1/4	1-1/4	369.00
7	1/4	1-1/4	366.05
7	3/8	1-1/4	399.99
7	1/2	1-1/4	436.05
7	9/16	1-1/4	448.08
7	5/8	1-1/4	466.99
7	3/4	1-1/4	515.99
7	7/8	1-1/4	578.99
7	1	1-1/4	633.95
8	1/4	1-1/4	398.09
8	1/4	1-1/2	398.09
8	5/16	1-1/4	405.98
8	5/16	1-1/2	405.98
8	3/8	1-1/4	429.00
8	3/8	1-1/2	429.00
8	1/2	1-1/4	473.35
8	1/2	1-1/2	473.35
8	9/16	1-1/2	528.09
8	5/8	1-1/4	528.00
8	5/8	1-1/2	528.00
8	3/4	1-1/4	569.09
8	3/4	1-1/2	569.09
8	13/16	1-1/4	625.09
8	7/8	1-1/4	635.09
8	7/8	1-1/2	667.95
8	15/16	1-1/4	719.99
8	1	1-1/2	719.99
9	3/8	1-1/4	639.89
9	1/2	1-1/4	719.95
9	5/8	1-1/4	764.98
9	3/4	1-1/4	819.99
9	1	1-1/4	919.99
10	1/4	1-1/2	773.96
10	5/16	1-1/2	847.96
10	3/8	1-1/2	893.95
10	7/16	1-1/2	979.98
10	1/2	1-1/2	1016.99
10	9/16	1-1/2	1039.98
10	5/8	1-1/2	1074.95
10	11/16	1-1/2	1123.98
10	3/4	1-1/2	1135.98
10	13/16	1-1/2	1184.95
10	7/8	1-1/2	1233.98
10	15/16	1-1/2	1293.98
10	1	1-1/2	1353.95
12	1/4	1-1/2	1310.98
12	5/16	1-1/2	1385.99
12	3/8	1-1/2	1399.99
12	7/16	1-1/2	1479.94
12	1/2	1-1/2	1479.94
12	5/8	1-1/2	1559.99
12	3/4	1-1/2	1699.97
12	7/8	1-1/2	1809.98
12	1	1-1/2	1899.95

MILLING CUTTERS



CONCAVE

● LIST NO. 736



For milling male half circles.

Cutter Dia.	Face Width	Hole Size	Price Each
1/16	2-1/4	1	69.99
3/32	2-1/4	1	69.99
1/8	2-1/4	1	69.99
5/32	2-1/4	1	69.99
3/16	2-1/4	1	69.99
7/32	2-1/4	1	79.00
1/4	2-1/2	1	79.00
9/32	2-1/2	1	99.00
5/16	2-3/4	1	99.00
11/32	2-3/4	1	110.00
3/8	2-3/4	1	110.00
13/32	2-3/4	1	129.00
7/16	3	1	129.00
1/2	2-1/4	7/8	135.00
1/2	3	1	135.00
9/16	3	1	166.50
5/8	2-3/4	1	166.50
5/8	3	1	166.50
5/8	3-1/2	1-1/4	166.50
11/16	3	1	199.00
3/4	3	1	199.00
3/4	3-3/4	1-1/4	199.00
13/16	3-1/4	1	250.00
13/16	3-1/4	1-1/4	250.00
7/8	3-1/4	1	250.00
7/8	4	1-1/4	250.00
15/16	3-1/2	1	299.99
1	3-1/4	1	299.99
1	4-1/4	1-1/4	299.99
1-1/16	4	1-1/4	485.00
1-1/8	4	1-1/4	485.00
1-3/16	3-1/4	1	485.00
1-1/4	4	1-1/4	485.00
1-3/8	4-1/4	1-1/4	575.00
1-1/2	4-1/4	1-1/4	650.00
1-5/8	5-1/2	1-1/4	695.00
1-3/4	5-1/2	1-1/4	825.00
1-7/8	6	1-1/2	899.00
2	6	1-1/2	975.00

CONVEX

● LIST NO. 737



For milling female half circles.

Cutter Dia.	Face Width	Hole Size	Price Each
1/16	2-1/4	1	65.99
3/32	2-1/4	1	65.99
1/8	2	7/8	65.99
1/8	2-1/4	1	65.99
5/32	2-1/4	1	65.99
3/16	2	7/8	65.99
3/16	2-1/4	1	65.99
7/32	2-1/4	1	77.99
1/4	2	7/8	77.99
1/4	2-1/4	1	77.99
1/4	2-1/2	1	77.99
9/32	2-1/2	1	95.35
5/16	2-3/4	1	95.35
11/32	2-3/4	1	95.35
3/8	2-1/4	7/8	99.99
3/8	2-1/2	1	99.99
3/8	2-3/4	1	99.99
13/32	2-3/4	1	99.99
7/16	3	1	114.69
1/2	2-1/4	7/8	124.00
1/2	3	1	124.00
9/16	2-3/4	1	158.00
9/16	3	1	158.00
5/8	2-3/4	1	158.00
5/8	3	1	158.00
5/8	3-1/2	1	158.00
5/8	3-1/2	1-1/4	158.00
11/16	3	1	196.00
3/4	3	1	196.00
3/4	3-3/4	1-1/4	196.00
13/16	3-1/4	1	223.89
7/8	3-1/4	1	223.89
7/8	4	1-1/4	223.89
15/16	3-1/2	1	249.00
1	3-1/4	1	249.00
1	4-1/4	1-1/4	249.00
1-1/8	4	1-1/4	379.15
1-1/4	4	1-1/4	379.15
1-3/8	4-1/4	1-1/4	441.44
1-1/2	4-1/4	1-1/4	484.85
1-5/8	5-1/2	1-1/4	542.90
1-3/4	5-1/2	1-1/4	637.66
1-7/8	6	1-1/2	694.62
2	6	1-1/2	795.00

PLAIN - HEAVY DUTY

● LIST NO. 741HD

For heavy stock removal furnished with 45° left hand helix.

Cutter Dia.	Face Width	Hole Size	Price Each
2-1/2	2	1	112.65
2-1/2	4	1	190.05
3	2	1-1/4	146.90
3	2-1/2	1-1/4	178.45
3	3	1-1/4	198.20
3	4	1-1/4	256.50
3	6	1-1/4	425.15
4	2	1-1/2	221.55
4	3	1-1/2	327.65
4	4	1-1/2	462.95
4	6	1-1/2	668.10
4-1/2	6	2	945.21

HELICAL PLAIN MILLING CUTTER

45° LEFT HAND HELIX

● LIST NO. 742



For slab of face milling mild steels ideal for light or intermittent cut on thin parts. They can be run at high speeds and produce smooth finishes without leaving feed marks.

Cutter Dia.	Face Width	Hole Size	Price Each
3	4	1-1/4	350.99
3	6	1-1/4	625.99
4	4	1-1/2	795.00
4	6	1-1/2	925.00
4	8	1-1/2	1195.00
4-1/2	12	2	2350.00



PLAIN - LIGHT DUTY

● LIST NO. 741

For light milling or finishing cuts. Cutters less than 3/4" width have straight teeth. Cutters 3/4" and over are furnished with 20° left hand helix.

Cutter Dia.	Face Width	Hole Size	Price Each
2-1/2	3/16	1	29.63
2-1/2	1/4	1	35.59
2-1/2	5/16	1	37.45
2-1/2	3/8	7/8	40.69
2-1/2	3/8	1	40.69
2-1/2	7/16	1	46.29
2-1/2	1/2	1	46.29
2-1/2	5/8	1	50.94
2-1/2	3/4	1	55.85
2-1/2	1	1	67.59
2-1/2	1-1/2	1	87.20
2-1/2	2	1	104.85
2-1/2	2-1/2	1	126.54
2-1/2	3	1	138.75
3	3/16	1	36.05
3	1/4	1	45.49
3	1/4	1-1/4	45.49
3	5/16	1	50.49

Cutter Dia.	Face Width	Hole Size	Price Each
3	3/8	1	53.85
3	3/8	1-1/4	53.85
3	7/16	1	57.85
3	7/16	1-1/4	57.85
3	1/2	1	59.85
3	1/2	1-1/4	59.85
3	5/8	1	65.67
3	5/8	1-1/4	65.67
3	3/4	1	68.09
3	3/4	1-1/4	68.09
3	7/8	1	69.59
3	7/8	1-1/4	69.59
3	1	1-1/4	88.15
3	1-1/4	1-1/4	99.35
3	1-1/2	1-1/4	111.15
3	2	1-1/4	136.40
3	2-1/2	1-1/4	172.10
3	3	1-1/4	191.20

Cutter Dia.	Face Width	Hole Size	Price Each
4	3/16	1	65.00
4	1/4	1	68.11
4	1/4	1-1/4	68.11
4	5/16	1	73.45
4	5/16	1-1/4	73.45
4	3/8	1	77.40
4	3/8	1-1/4	77.40
4	7/16	1-1/4	94.00
4	1/2	1-1/4	94.59
4	9/16	1-1/4	100.00
4	5/8	1	100.39
4	5/8	1-1/4	100.39
4	3/4	1-1/4	110.65
4	1	1-1/4	132.90
4	1-1/2	1-1/4	171.39
4	2	1-1/4	211.05
4	3	1-1/4	311.35
4	4	1-1/4	411.59

MILLING CUTTERS



SINGLE ANGLE

- LIST NO. 720R — 45° RIGHT HAND
- LIST NO. 720L — 45° LEFT HAND
- LIST NO. 721R — 60° RIGHT HAND
- LIST NO. 721L — 60° LEFT HAND



DOUBLE ANGLE

- LIST NO. 722 — 45°
- LIST NO. 723 — 60°
- LIST NO. 724 — 90°

These cutters are utilized for milling ratchett teeth or dovetails.

Cutter Dia.	Face Width	Hole Size	Price Each			
			List No. 720R	List No. 720L	List No. 721R	List No. 721L
2-1/2	1/2	7/8	75.65	75.65	75.65	75.65
2-3/4	1/2	1	84.75	84.75	84.75	84.75
3	1/2	1	102.75	102.75	102.75	102.75
3	1/2	1-1/4	102.75	102.75	102.75	102.75
3	5/8	1	149.00	149.00	149.00	149.00
3	5/8	1-1/4	149.00	149.00	149.00	149.00
3	3/4	1	165.49	165.49	165.49	165.49
3	3/4	1-1/4	165.49	165.49	165.49	165.49
4	1/2	1	184.95	184.95	184.95	184.95
4	1/2	1-1/4	216.50	216.50	216.50	216.50
4	3/4	1	238.25	238.25	238.25	238.25
4	3/4	1-1/4	238.25	238.25	238.25	238.25
4	1	1-1/4	238.25	238.25	238.25	238.25
5	3/4	1-1/4	275.25	275.25	275.25	275.25
5	1	1-1/4	324.40	324.40	324.40	324.40
6	3/4	1-1/4	368.30	368.30	368.30	368.30
6	1	1-1/4	438.80	438.80	438.80	438.80

Double angle cutters are used for milling notches, grooves, serrations, or threads.

Cutter Dia.	Face Width	Hole Size	Price Each		
			List No. 722	List No. 723	List No. 724
2-3/4	1/2	1	78.50	78.50	78.50
3	5/8	1	155.09	155.09	155.09
3	3/4	1	169.09	169.09	169.09
4	1/2	1-1/4	178.40	178.40	178.40
4	3/4	1	221.25	221.25	221.25
4	3/4	1-1/4	244.00	244.00	244.00
4	1	1-1/4	244.00	244.00	244.00
5	3/4	1-1/4	264.00	264.00	264.00
5	1	1-1/4	264.00	264.00	264.00
6	3/4	1-1/4	409.50	409.50	409.50
6	1	1-1/4	419.00	419.00	419.00
6	1-1/2	1-1/4	593.75	593.75	593.75

SHANK TYPE MILLING CUTTERS

WELDON SHANK

To be used in Manual or NC Machining Centers. These cutters are preferred over form relief type cutters.



CONCAVE

For milling male half circles.

- LIST NO. 736S

Radius	Cutter Diameter	Overall Length	Shank Diameter	No. of Flutes	Price Each
1/32	3/4	3	1/2	6	60.08
1/16	3/4	3	1/2	6	60.08
3/32	3/4	3	1/2	6	60.08
1/8	1	3-1/2	3/4	6	71.89
5/32	1	3-1/2	3/4	6	76.99
3/16	1	3-1/2	3/4	6	98.09
1/4	1-1/4	4	3/4	4	98.09
5/16	1-1/4	4	3/4	4	108.99
3/8	1-1/2	4-3/16	3/4	4	129.49



CONVEX

For milling female half circles.

- LIST NO. 737S

Radius	Cutter Diameter	Overall Length	Shank Diameter	No. of Flutes	Price Each
1/32	3/4	3	1/2	6	68.09
1/16	3/4	3	1/2	6	65.09
3/32	7/8	3	1/2	6	68.08
1/8	1-1/4	3-1/2	3/4	6	72.39
5/32	1-5/16	3-1/2	3/4	6	79.29
3/16	1-3/8	3-1/2	3/4	6	82.99
1/4	1-1/2	4	3/4	6	92.39
5/16	1-5/8	4	3/4	6	124.08
3/8	1-3/4	4	3/4	6	129.79

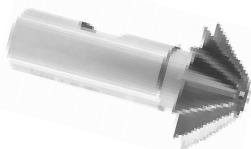

SINGLE ANGLE

For chamfers and other angular milling operations.

- LIST NO. 745 — 45° INCLUDED ANGLE
- LIST NO. 746 — 60° INCLUDED ANGLE

Cutter Dia.	Shank Dia.	Overall Length	Price Each			
			45° Angle		60° Angle	
			Cutter Width	List No. 745	Cutter Width	List No. 746
1/2	3/8	2-1/8	1/8	51.50	7/32	51.50
3/4	3/8	2-1/8	3/16	60.41	5/16	60.41
1	1/2	2-1/2	5/16	75.08	7/16	75.08
1-1/2	3/4	2-3/4	1/2	96.90	5/8	96.90



DOUBLE ANGLE

For notches, V-Grooves and other angular milling operations.

- LIST NO. 747 — 60° INCLUDED ANGLE
- LIST NO. 748 — 90° INCLUDED ANGLE

Cutter Dia.	Shank Dia.	Overall Length	Price Each				
			60° Angle		90° Angle		
			Cutter Width	List No. 747	Overall Length	Cutter Width	List No. 748
3/4	3/8	2-3/8	3/16	40.92	2-7/16	1/4	40.92
1	1/2	2-7/8	5/16	65.50	2-7/8	3/8	65.50
1-3/8	5/8	3-7/32	7/16	87.33	3-1/4	1/2	87.33
1-1/2	5/8	3-3/8	1/2	114.53	3-7/16	9/16	114.53
1-7/8	3/4	3-13/16	5/8	132.75	3-3/4	5/8	132.75
2-1/4	3/4	3-1/8	1/2	194.53	3-1/8	1/2	194.53
2-1/4	7/8	4-1/8	3/4	194.53	4-1/8	3/4	194.53

INVOLUTE GEAR CUTTERS

Involute Gear Cutters are used to mill gears with a 14-1/2° or 20° pressure angle. Eight (8) cutters are required to make a full set of gears from (12) teeth to a rack for each diametral pitch.

Eight cutters are made for each pitch diameter:

No.1 will cut135 teeth to a rack	No.5 will cut 21 - 25 teeth
No.2 will cut 55 -134 teeth	No.6 will cut 17 - 20 teeth
No.3 will cut 35 - 54 teeth	No.7 will cut 14 - 16 teeth
No.4 will cut 26 - 34 teeth	No.8 will cut 12 - 13 teeth

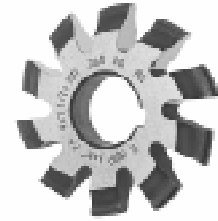

Please specify cutter number when ordering.

● LIST NO. 730 — 14-1/2° PRESSURE ANGLE

Dia. Pitch	Cutter Dia.	Hole Size	Price Each
1	8-1/2	2	1990.00
1-1/4	7-3/4	2	1400.00
1-1/2	7	1-3/4	995.00
1-3/4	6-1/2	1-3/4	850.00
2	5-3/4	1-1/2	544.70
2-1/2	5-3/4	1-1/2	424.58
3	4-3/4	1-1/4	298.97
4	3-5/8	1	185.57
4	4-1/4	1-1/4	210.40
4	4-1/2	1-1/2	225.46
5	3-3/8	1	160.96
5	3-3/4	1-1/4	165.96
6	3-1/8	1	130.44
6	3-1/2	1-1/4	148.72
7	2-7/8	1	130.83
7	3-3/8	1-1/4	148.72

Dia. Pitch	Cutter Dia.	Hole Size	Price Each
8	2-7/8	1	107.99
8	3-1/4	1-1/4	125.13
9	2-3/4	1	107.26
10	2-3/8	7/8	85.43
10	2-3/4	1	96.86
11	2-3/8	7/8	85.43
11	2-5/8	1	93.58
12	2-1/4	7/8	75.49
12	2-5/8	1	85.43
14	2-1/8	7/8	73.54
14	2-1/2	1	86.10
16	2-1/8	7/8	73.54
16	2-1/8	1	86.10
18	2	7/8	65.50
18	2-3/8	1	78.22
20	2	7/8	65.50
20	2-3/8	1	78.22

Dia. Pitch	Cutter Dia.	Hole Size	Price Each
22	2	7/8	65.50
24	1-3/4	7/8	65.50
24	2-1/4	1	78.22
26	1-3/4	7/8	65.50
26	2-1/4	1	78.22
28	1-3/4	7/8	65.50
28	2-1/4	1	78.22
30	1-3/4	7/8	65.50
30	2-1/4	1	78.22
32	1-3/4	7/8	61.05
32	2-1/4	1	69.81
36	1-3/4	7/8	61.05
36	2-1/4	1	69.81
40	1-3/4	7/8	61.05
48	1-3/4	7/8	61.05
48	2-1/4	1	69.81
60	1-3/4	7/8	61.05

● LIST NO. 731 — 20° PRESSURE ANGLE

Dia. Pitch	Cutter Dia.	Hole Size	Price Each
1	8-1/2	2	2100.00
1-1/4	7-3/4	2	1550.00
1-1/2	7	1-3/4	1075.00
1-3/4	6-1/2	1-3/4	920.00
2	5-3/4	1-1/2	544.70
2-1/2	5-3/4	1-1/2	424.58
3	4-3/4	1-1/4	298.97
4	3-5/8	1	185.57
4	4-1/4	1-1/4	210.40
5	3-3/8	1	160.96
5	3-3/4	1-1/4	165.96
6	3-1/8	1	130.44
6	3-1/2	1-1/4	148.72
7	2-7/8	1	130.83

Dia. Pitch	Cutter Dia.	Hole Size	Price Each
8	2-7/8	1	107.99
8	3-1/4	1-1/4	125.13
9	2-3/4	1	107.26
10	2-3/8	7/8	85.43
10	2-3/4	1	96.86
11	2-5/8	1	93.58
12	2-1/4	7/8	75.49
12	2-5/8	1	85.43
14	2-1/8	7/8	73.54
14	2-1/2	1	86.10
16	2-1/8	7/8	73.54
16	2-1/8	1	86.10
18	2	7/8	65.50
18	2-3/8	1	78.22
20	2	7/8	65.50
20	2-3/8	1	78.22

Dia. Pitch	Cutter Dia.	Hole Size	Price Each
22	2	7/8	65.50
24	1-3/4	7/8	65.50
24	2-1/4	1	78.22
26	1-3/4	7/8	65.50
26	2-1/4	1	78.22
28	1-3/4	7/8	65.50
28	2-1/4	1	78.22
30	1-3/4	7/8	65.50
30	2-1/4	1	78.22
32	1-3/4	7/8	61.05
32	2-1/4	1	69.81
36	1-3/4	7/8	61.05
36	2-1/4	1	69.81
40	1-3/4	7/8	61.05
48	1-3/4	7/8	61.05
48	2-1/4	1	69.81
60	1-3/4	7/8	61.05

CORNER ROUNDING MILLING CUTTERS

ARBOR TYPE

- LIST NO. 732R, RIGHT HAND CUTTER
- LIST NO. 732L, LEFT HAND CUTTER

These cutters are designed to mill radii on various materials.

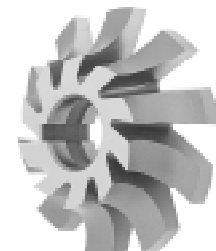
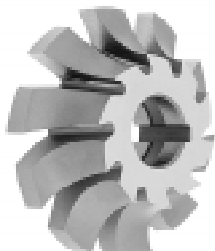

Radius of Circle	Cutter Diameter	Face Width	Hole Size	Price Each	
				List No. 732R	List No. 732L
1/8	2	1/4	7/8	59.00	59.00
1/8	2-1/2	1/4	1	75.00	75.00
3/16	2-1/2	5/16	1	125.00	125.00
1/4	3	13/32	1	99.50	99.50
3/8	3	9/16	1	110.00	110.00
3/8	3-3/4	9/16	1-1/4	145.00	145.00
1/2	3-1/4	3/4	1	159.00	159.00
1/2	4-1/4	3/4	1-1/4	198.00	198.00
5/8	3-1/2	15/16	1	215.00	215.00
5/8	4-1/4	15/16	1-1/4	225.00	225.00

• WOODRUFF KEY SEAT CUTTERS

1/2 DIAMETER — STRAIGHT SHANK

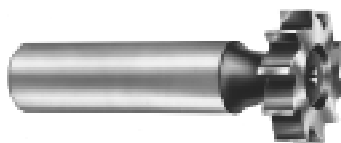

For cutting standard and woodruff keyways in steel and other ferrous materials.

Nominal Diameter	Face Width	Overall Length	American Standard #	Tool No.	Price Each
1/4	1/16	2-1/16	202	KC202	19.15
5/16	1/16	2-1/16	202-1/2	KC202-1/2	19.15
5/16	3/32	2-3/32	302-1/2	KC302-1/2	19.15
3/8	1/16	2-1/16	203	KC203	19.15
3/8	3/32	2-3/32	303	KC303	19.15
3/8	1/8	2-1/8	403	KC403	19.15
1/2	1/16	2-1/16	204	KC204	19.15
1/2	3/32	2-3/32	304	KC304	19.15
1/2	1/8	2-1/8	404	KC404	19.15
5/8	3/32	2-3/32	305	KC305	19.15
5/8	1/8	2-1/8	405	KC405	19.15
5/8	5/32	2-5/32	505	KC505	19.15
5/8	3/16	2-3/16	605	KC605	19.15
3/4	1/8	2-1/8	406	KC406	19.15
3/4	5/32	2-5/32	506	KC506	20.33
3/4	3/16	2-3/16	606	KC606	20.33
3/4	1/4	2-1/4	806	KC806	20.33
7/8	5/32	2-5/32	507	KC507	22.63
7/8	3/16	2-3/16	607	KC607	22.63
7/8	7/32	2-7/32	707	KC707	22.63
7/8	1/4	2-1/4	807	KC807	22.63

Nominal Diameter	Face Width	Overall Length	American Standard #	Tool No.	Price Each
1	3/16	2-3/16	608	KC608	24.40
1	7/32	2-7/32	708	KC708	24.40
1	1/4	2-1/4	808	KC808	24.40
1	5/16	2-5/16	1008	KC1008	24.97
1	3/8	2-3/8	1208	KC1208	24.97
1-1/8	3/16	2-3/16	609	KC609	27.30
1-1/8	7/32	2-7/32	709	KC709	27.30
1-1/8	1/4	2-1/4	809	KC809	27.30
1-1/8	5/16	2-5/16	1009	KC1009	29.05
1-1/4	3/16	2-3/16	610	KC610	30.20
1-1/4	7/32	2-7/32	710	KC710	30.20
1-1/4	1/4	2-1/4	810	KC810	31.36
1-1/4	5/16	2-5/16	1010	KC1010	32.53
1-1/4	3/8	2-3/8	1210	KC1210	32.53
1-3/8	1/4	2-1/4	811	KC811	34.85
1-3/8	5/16	2-5/16	1011	KC1011	34.85
1-3/8	3/8	2-3/8	1211	KC1211	36.03
1-1/2	1/4	2-1/4	812	KC812	36.03
1-1/2	5/16	2-5/16	1012	KC1012	36.03
1-1/2	3/8	2-3/8	1212	KC1212	38.35

SETS

SET NO. KCS1

10 Piece Set
Contains 1 piece of each:
KC204, KC305, KC403,
KC404, KC406, KC505,
KC606, KC608, KC806, KC808
Supplied in wood block.

SET PRICE — \$204.00

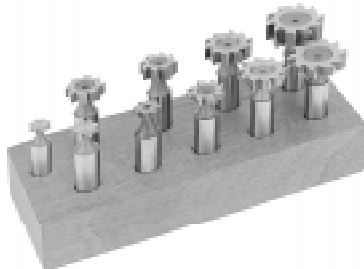

SET NO. KCS2

41 Piece Set
Contains 1 piece of each:
KC202 thru KC1212
Supplied in a wood case.

SET PRICE — \$1025.00



• STAGGERED TOOTH WOODRUFF KEY SEAT CUTTERS

ARBOR TYPE

Nominal Diameter	Face Width	Hole Size	American Standard #	Tool No.	Price Each
2-1/8	3/16	3/4	617	KCA617	49.50
2-1/8	1/4	3/4	817	KCA817	51.75
2-1/8	5/16	3/4	1017	KCA1017	57.75
2-1/8	3/8	3/4	1217	KCA1217	65.00
2-3/4	1/4	1	822	KCA822	71.40
2-3/4	5/16	1	1022	KCA1022	75.60
2-3/4	3/8	1	1222	KCA1222	79.90
2-3/4	7/16	1	1422	KCA1422	84.00
2-3/4	1/2	1	1622	KCA1622	89.90
3-1/2	3/8	1	1228	KCA1228	108.75
3-1/2	7/16	1	1428	KCA1428	116.75
3-1/2	1/2	1	1628	KCA1628	120.00
3-1/2	9/16	1	1828	KCA1828	135.00
3-1/2	5/8	1	2028	KCA2028	135.00
3-1/2	11/16	1	2228	KCA2228	139.50
3-1/2	3/4	1	2428	KCA2428	139.50

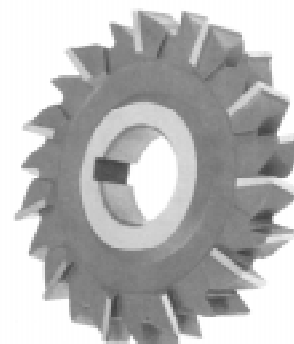



MADE IN U.S.A.

◆ NMTB QUICK CHANGE TOOLING

Hardened and Ground Throughout

These Quick Change Adapters are designed to interchange with Erickson Style Holders and all No. 30 and No. 40 standard milling machine tapers. This tooling will also fit holders and spindles commonly used on the Bridgeport® Series I and Series II CNC Milling Machines and other similar milling machines.

FITS ERICKSON STYLE HOLDERS!



MORSE TAPER ADAPTERS

Morse Taper I.D.	Quick Change Taper	No. 30 Taper		No. 40 Taper	
		Tool No.	Price Each	Tool No.	Price Each
1	30, -	QCM3-1	66.00	-	-
2	30, 40	QCM3-2	86.00	QCM4-2	88.00
3	30, 40	QCM3-3	86.00	QCM4-3	88.00
4	30, 40	QCM3-4	94.00	QCM4-4	97.00
5	- , 40	-	-	QCM4-5	124.00

END MILL ADAPTERS

Diameter of Hole	Quick Change Taper	No. 30 Taper		No. 40 Taper	
		Tool No.	Price Each	Tool No.	Price Each
3/16	30, 40	QCE3-187	83.00	QCE4-187	99.00
3/8	30, 40	QCE3-375	83.00	QCE4-375	93.50
1/2	30, 40	QCE3-500	83.00	QCE4-500	93.50
5/8	30, 40	QCE3-625	90.00	QCE4-625	97.00
3/4	30, 40	QCE3-750	90.00	QCE4-750	97.00
7/8	30, 40	QCE3-875	94.00	QCE4-875	105.00
1	30, 40	QCE3-1000	98.00	QCE4-1000	118.00
1-1/4	30, 40	QCE3-1250	108.00	QCE4-1250	128.00

Replacement screws are available. Please Inquire.

SHELL AND FACEMILL ADAPTERS

Pilot Diameter	Quick Change Taper	No. 30 Taper		No. 40 Taper	
		Tool No.	Price Each	Tool No.	Price Each
1/2	30, 40	QCS3-500	102.00	QCS4-500	109.00
3/4	30, 40	QCS3-750	106.00	QCS4-750	109.00
1	30, 40	QCS3-1000	107.00	QCS4-1000	133.00
1-1/4	30, 40	QCS3-1250	133.00	QCS4-1250	133.00
1-1/2	30, 40	QCS3-1500	140.00	QCS4-1500	148.00

Replacement Screws and Arbor Keys are Available. Please Inquire.

JACOBS TAPER ADAPTERS

Jacobs Taper	Quick Change Taper	No. 30 Taper		No. 40 Taper	
		Tool No.	Price Each	Tool No.	Price Each
1	30, -	QCJ3-1	94.00	-	-
2	30, 40	QCJ3-2	86.00	QCJ4-2	88.00
3	30, 40	QCJ3-3	86.00	QCJ4-3	88.00
33	30, 40	QCJ3-33	86.00	QCJ4-33	88.00
4	30, 40	QCJ3-4	89.00	QCJ4-4	97.00
6	30, 40	QCJ3-6	89.00	QCJ4-6	104.00

ARBORS, ADAPTERS AND CLAMP SETS

◆ SHELL END MILL ARBORS WITH NST SHANK

These arbors are made of alloy forged steel for a more durable service life.



NST Shank	Diameter of Bore	Diameter Range of Shell End Mill	Tool No.	Price Each
30	1/2	1-1/4 to 1-1/2	HS3012	72.80
30	3/4	1-3/4 to 2	HS3034	72.80
30	1	2-1/4 to 2-3/4	HS301	72.80
30	1-1/4	3 to 3-1/2	HS30114	72.80
40	1/2	1-1/4 to 1-1/2	HS4012	99.00
40	3/4	1-3/4 to 2	HS4034	99.00
40	1	2-1/4 to 2-3/4	HS401	99.00
40	1-1/4	3 to 3-1/2	HS40114	99.00
40	1-1/2	4 to 5	HS40112	99.00
40	2	5-1/2 to 6	HS402	99.00
50	1/2	1-1/4 to 1-1/2	HS5012	149.00
50	3/4	1-3/4 to 2	HS5034	149.00
50	1	2-1/4 to 2-3/4	HS501	149.00
50	1-1/4	3 to 3-1/2	HS50114	149.00
50	1-1/2	4 to 5	HS50112	149.00
50	2	5-1/2 to 6	HS502	149.00

◆ SHELL END MILL ARBORS WITH R8 SHANK

Bore Dia. for Standard Shell	Dia. Range of Standard Shell	Tool No.	Price Each
1/2	1-1/4 to 1-1/2	R8S12	54.75
3/4	1-3/4 to 2	R8S34	54.75
1	2-1/4 to 2-3/4	R8S1	58.75
1-1/4	3 to 3-1/2	R8S114	58.75
1-1/2	4 to 5	R8S112	78.75



SET NO. R8 SHELL

5 Piece Set
Contains 1 piece of each:
1/2, 3/4, 1", 1-1/4, 1-1/2
Supplied in wood block.

SET PRICE - \$299.00

◆ SLITTING SAW AND STUB MILLING MACHINE ARBORS WITH R8 SHANK

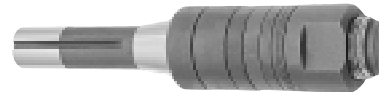

These arbors are made of alloy forged steel for a more durable service life.

Dia. of Arbor	Shoulder to Nut	Tool No.	Price Each
1	2"	R8SM1	85.00
1-1/4	2"	R8SM114	92.50

Supplied with spacers. Replacement spacers, nuts, and arbor keys available. Please inquire.

◆ SLITTING AND SLOTTING SAW ARBOR

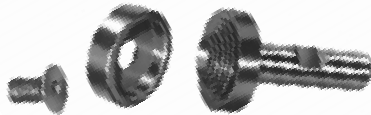

This arbor offers flexibility in sawing operations. The spring-loaded mechanism accepts saw-blades with hole diameters from 1/2" to 1". Blades are firmly held in position with a flat head socket cap screw.

Shank Diameter	Overall Length	Tool No.	Price Each
1/2" Weldon R-8	2-9/16	HSA12	19.50
	5-3/32	HSAR8	21.75

◆ MILLING MACHINE ADAPTERS

Hardened and Ground

For changing from National Standard Taper to Morse Taper



Open End Type and Drawbar End Type

Outside Taper	Inside Taper	Open End Tool No.	Draw Bar End Type Tool No.	Price Each
40	2	HP40-2	HPD40-2	79.00
40	3	HP40-3	HPD40-3	79.00
40	4	HP40-4	HPD40-4	79.00
40	5	HP40-5	HPD40-5	98.50
50	2	HP50-2	HPD50-2	110.00
50	3	HP50-3	HPD50-3	110.00
50	4	HP50-4	HPD50-4	110.00
50	5	HP50-5	HPD50-5	144.00



Reducing Type

Outside Taper	Inside Taper	Tool No.	Price Each
40	30	HR40-30	120.00
50	30	HR50-30	129.75
50	40	HR50-40	129.75

For changing a larger National Standard Taper to a smaller one.

Federal Tool Premium Import

◆ 52-PC CLAMPING SET

For Bridgeport Type Machines

• Table T-Slot Size 5/8" • Stud Size 1/2"-13



SET NO. CPK52

52 Piece Set
Each Set Contains:
- 24 Studs - 4 Pcs EA:
3, 4, 5, 6, 7 & 8 long
- 4 Coupling nuts
- 6 Forged steel step clamps
- 6 T - slot nuts
- 6 Flange nuts
- 6 Steel step blocks

Supplied in fitted rack for mounting on wall or machine

SET PRICE - \$69.95



UNI-KUT FLY TOOL CUTTERS

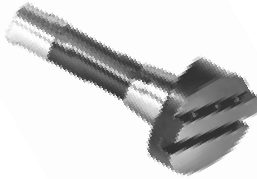

- Uses inexpensive standard tool bits
- Makes wider cuts than end mills
- Saves purchase and re-grind costs of end mills
- Faster speeds and better finishes
- Less chatter and free cutting on thin material or non-rigid set ups

Head Diameter	Shank Size	Tool Bit Size	Tool No.	Price Each
STRAIGHT SHANK				
3/4	1/2	3/16	K121	10.95
1-1/8	1/2	1/4	K122	12.50
1-3/8	1/2	5/16	K123	13.95
1-3/8	3/4	5/16	K341	22.50
1-1/2	3/4	3/8	K341A	23.25
2	3/4	5/16	K342	23.75
2	3/4	3/8	K342A	24.50
2-1/2	3/4	5/16	K343	27.50
2-1/2	3/4	1/2	K343A	28.50
R-8 SHANK				
2-1/2	R-8	5/16	K348	44.50

Tool Bits are featured on pages 122 and 123.

Federal Tool Premium Import

HIGH SPEED STEEL AND COBALT

"T" SLOT CUTTERS

- LIST NO. 749 — HIGH SPEED STEEL
- LIST NO. 749CR — COBALT ROUGHING



For milling T-Slots in tables and beds of machine tools

Bolt Size	Dia. of Cutter	Cutter Width	Dia. of Neck	Dia. of Shank	Overall Length	Price Each	
						List No. 749	List No. 749CR
1/4	9/16	15/64	17/64	1/2	2-19/32	48.00	—
5/16	21/32	17/64	21/64	1/2	2-11/16	52.80	—
3/8	25/32	21/64	13/32	3/4	3-1/4	66.00	—
1/2	31/32	25/64	17/32	3/4	3-7/16	75.60	115.00
5/8	1-1/4	31/64	21/32	1	3-15/16	102.60	148.00
3/4	1-15/32	5/8	25/32	1	4-7/16	110.00	163.00
1	1-27/32	53/64	1-1/32	1-1/4	4-13/16	191.00	285.00
1-1/4	2-7/32	1-3/32	1-9/32	1-1/4	5-3/8	239.50	345.00
1-1/2	2-21/32	1-11/32	1-17/32	1-1/4	5-29/32	306.00	440.00

SET NO. 749S

7 Piece Set - High Speed Steel
Contains 1 piece of each:
1/4 thru 1"
Supplied in wood block.
SET PRICE — \$645.00

SET NO. 749CRS

4 Piece Set - Cobalt Roughing
Contains 1 piece of each:
1/2 thru 1"
Supplied in wood block.
SET PRICE — \$710.00

SETS

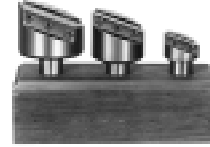

SET NO. K120

1/2" STRAIGHT SHANKS

3 Piece Set
Contains 1 piece of each:
K121, K122, K123
Supplied in wood block.

SET PRICE — \$36.95

SET NO. K340

3/4" STRAIGHT SHANKS

3 Piece Set with 5/16" Tool Bits
Contains 1 piece of each:
K341, K342, K343
Supplied in wood block.

SET PRICE — \$73.75

SET NO. K340A

3/4" STRAIGHT SHANKS

3 Piece Set with 3/8" Tool Bits
Contains 1 piece of each:
K141A, K342A, K343A
Supplied in wood block.

SET PRICE — \$76.50

SET NO. K340B

1/2" AND 3/4" SHANKS

6 Piece Set with 3/16,
1/4 and 5/16 Tool Bits
Contains 1 piece of each:
K121, K122, K123
K341, K342, K343
Supplied in wood block.

SET PRICE — \$109.00

Federal Tool Premium Import

HIGH SPEED STEEL AND COBALT

DOVETAIL CUTTERS

45° LEAD ANGLE

- LIST NO. 275 — HIGH SPEED STEEL
- LIST NO. 275C — COBALT

60° LEAD ANGLE

- LIST NO. 276 — HIGH SPEED STEEL
- LIST NO. 276C — COBALT

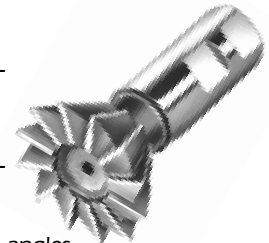

For cutting dovetails and angles.

Diameter of Cut	Width of Cut	Shank Diameter	Overall Length	Price Each	
				H. S.	Cobalt
45° LEAD ANGLE				List No. 275	List No. 275C
3/8	1/8	3/8	2-1/8	42.50	70.12
1/2	1/8	3/8	2-1/8	44.89	74.07
3/4	3/16	3/8	2-1/8	54.35	89.67
1- 3/8	3/8	5/8	2-7/8	89.50	147.68
1- 7/8	1/2	7/8	3-1/4	174.00	287.00
2- 1/4	11/16	1	3-3/4	207.40	342.00
60° LEAD ANGLE				List No. 276	List No. 276C
3/8	1/8	3/8	2-1/8	42.50	70.12
1/2	7/32	3/8	2-1/8	44.89	74.07
3/4	5/16	3/8	2-1/8	54.35	89.67
1- 3/8	9/16	5/8	2-7/8	89.50	147.68
1- 7/8	13/16	7/8	3-1/4	174.00	287.00
2- 1/4	1-1/16	1	3-3/4	207.40	342.00

45° H.S. SET NO. 275S

60° H.S. SET NO. 276S
4 Piece Set
Contains 1 piece of each:
3/8 thru 1-3/8
Supplied in wood block
SET PRICE — \$219.00

45° COBALT SET NO. 275CS

60° COBALT SET NO. 276CS
4 Piece Set
Contains 1 piece of each:
3/8 thru 1-3/8
Supplied in wood block
SET PRICE — \$359.00



◆ UNO-DEX® INDEXABLE FLY CUTTER

- LOW COST • RUGGED CONSTRUCTION FOR LONG TOOL LIFE • ONE CLAMP FITS ALL TOOL SIZES
- USES STANDARD INEXPENSIVE INSERTS • PRODUCES WIDER CUTS THAN END MILLS

SINGLE FLUTE — TRIANGLE INSERTED — POSITIVE RAKE — 90° CUT

TRIANGLE INSERTED			
Cutting and Head Dia.	Shank Dia. or Style	Tool Number	Price Each
1-1/2	3/4	KT150-34	64.00
1-1/2	R-8	KT150-R8	75.00
2	3/4	KT200-34	73.00
2	R-8	KT200-R8	85.00
2-1/2	3/4	KT250-34	86.00
2-1/2	R-8	KT250-R8	102.00
3	3/4	KT300-34	101.00
3	R-8	KT300-R8	114.00

Inserts sold separately.



SETS	
3/4" SHANK	
SET NO. KT750 Contains 1 Piece Each 1-1/2, 2, 2-1/2, 3 Supplied in wood block SET PRICE — \$324.00	
R-8 SHANK	
SET NO. KTR8 Contains 1 Piece Each 1-1/2, 2, 2-1/2, 3 Supplied in wood block SET PRICE — \$376.00	

TPG TRIANGLE — Positive rake ground all over						
CARBIDE INSERTS						
Insert Number	Radius	I.C.	Thickness	Price Each		
				C-2	C-5 & C-6	TiN Coated*
TPG-321	1/64	3/8	1/8	4.89	5.18	6.21
TPG-322	1/32	3/8	1/8	4.89	5.18	6.21
TPG-323	3/64	3/8	1/8	4.89	5.18	6.21
TPG-324	1/16	3/8	1/8	4.89	5.18	6.21

*C-5 & C-6 Grade TiN Coated

TPC TRIANGLE — Positive rake ground all over with wiping flats on three corners						
CARBIDE INSERTS WITH WIPING FLATS						
Insert Number	Radius	I.C.	Thickness	Price Each		
				C-2	C-5 & C-6	TiN Coated*
TPC-32ZR	—	3/8	1/8	4.80	4.98	5.85

*C-5 & C-6 Grade TiN Coated

REPLACEMENT PARTS LIST		
Part No.	Description	Price Each
CTD-2	Hold Down Clamp	5.55
CS832-12	Clamp Screw	.50
CSW	9/64 Allen Wrench for 8-32 Screw	.50

SINGLE FLUTE — SQUARE INSERTED — POSITIVE RAKE — 45° CUT

SQUARE INSERTED			
Cutting and Head Dia.	Shank Dia. or Style	Tool Number	Price Each
1-1/2	3/4	KX150-34	64.00
1-1/2	R-8	KX150-R8	75.00
2	3/4	KX200-34	73.00
2	R-8	KX200-R8	85.00
2-1/2	3/4	KX250-34	86.00
2-1/2	R-8	KX250-R8	102.00
3	3/4	KX300-34	101.00
3	R-8	KX300-R8	114.00

Inserts sold separately.



SETS	
3/4" SHANK	
SET NO. KX750 Contains 1 Piece Each 1-1/2, 2, 2-1/2, 3 Supplied in wood block SET PRICE — \$324.00	
R-8 SHANK	
SET NO. KXR8 Contains 1 Piece Each 1-1/2, 2, 2-1/2, 3 Supplied in wood block SET PRICE — \$376.00	

SPG SPU						
CARBIDE INSERTS						
Insert Number	Radius	I.C.	Thickness	Price Each		
				C-2	C-5 & C-6	TiN Coated*
SPG-422	1/32	1/2	1/8	4.75	5.12	5.80
SPG-423	3/64	1/2	1/8	4.75	5.12	5.80
SPG-424	1/16	1/2	1/8	4.75	5.12	5.80
SPU-422	1/32	1/2	1/8	4.10	4.46	5.13
SPU-423	3/64	1/2	1/8	4.10	4.46	5.13

*C-5 & C-6 Grade TiN Coated

SPC SQUARE — Positive rake ground all over with wiping flats on four corners.						
CARBIDE INSERTS WITH WIPING FLATS						
Insert Number	Radius	I.C.	Thickness	Price Each		
				C-2	C-5 & C-6	TiN Coated*
SPC-42ZR	—	1/2	1/8	4.95	5.30	6.35

*C-5 & C-6 Grade TiN Coated

REPLACEMENT PARTS LIST		
Part No.	Description	Price Each
CTD-2	Hold Down Clamp	5.55
CS832-12	Clamp Screw	.50
CSW	9/64 Allen Wrench for 8-32 Screw	.50

THE



MULTI-TOOL SYSTEM

A simple, easy to use system for producing accurate holes at an economical cost!

- Produces accurate holes in a wide variety of machine tools from fixed or portable, light duty, low horsepower equipment to heavy duty applications in CNC lathes and machining centers
- For drilling, boring, spotfacing and counterboring applications from 7/8" to 4" in diameter
- Replaces costly taper shank drills
- A wide range of shank styles allows for easy adaptability throughout the shop

Made in USA

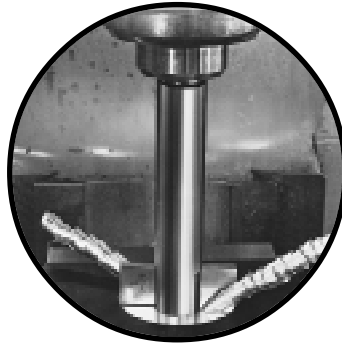

- Blades are available in high speed steel, cobalt, carbide indexable & titanium nitride coating for machining a wide range of material
- Blades can be modified for machining special step diameters or other profiles
- Standard sets available from stock
- A preferred choice for most machine shop, maintenance department, and light production holmaking applications

Piloted Holder



Blade



Pilot Drill



Auxiliary Pilot and Set Screw

SETS



Sets are available in both the 3/4" Pilot "D" Series for general purpose applications and the 1" Pilot "E" Series for those heavy duty job requirements.



— THE MULTI-TOOL SYSTEM — BLADES

Select the same cutting speeds and feed rates for Multi -Tool Blades as you would for drills of the same size.

HIGH SPEED STANDARD BLADE*

*May be TiN Coated for extended life



For General Purpose Applications on Ferrous and Non-Ferrous Materials Available in Standard "D" Series and Heavy Duty "E" Series

HIGH SPEED COMBINATION BLADE*

*May be TiN Coated for extended life



For Forward and Backward Counterbore and Spotface Applications Available in Standard "D" Series and Heavy Duty "E" Series

S-TYPE BLADE



For Large Diameter Holes (3-1/2" to 6") Heavy Duty "E" Series Only

COBALT STANDARD BLADE



For General Purpose Applications on Abrasive & Difficult-to-Machine Materials Heavy Duty "E" Series Only

COBALT COMBINATION BLADE



For Forward and Backward Counterbore & Spotface Applications on Abrasive & Difficult-to-Machine Materials

SPECIAL ORDER CHAMFERING BLADE



For Holes up to 4" Available in Standard "D" Series and Heavy Duty "E" Series

ADJUSTABLE DIAMETER CARBIDE INDEXABLE BLADE



For Use as a Single Point Cutting Tool or Boring Bar Heavy Duty "E" Series Only

FIXED DIAMETER CARBIDE INDEXABLE BLADE



For Higher Surface Speeds in Boring and Counterboring Heavy Duty "E" Series Only

SPECIAL ORDER MULTI-DIAMETER BLADE



For Multi-Diameter Geometries in a Single Pass Available in Standard "D" Series and Heavy Duty "E" Series

◆ BLADE GRINDING FIXTURES

RESIZING FIXTURE

TOOL NO. BRF2
PRICE EACH — \$74.00

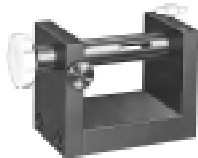

This fixture is designed for resizing blades up to 3" in diameter while maintaining concentricity. Standard blades can be modified to special diameters. The correct back taper is built into the fixture. Made with two index stops, the blade O.D. is relieved on the same set up after grinding the O.D. to desired size on any surface grinder.

Blade Grinding Fixtures make regrinding and blade modification simple while maintaining accuracy!

ARBOR FOR "D" SERIES BLADES

TOOL NO. BRF2D
PRICE EACH — \$40.00

ARBOR FOR "E" SERIES BLADES

TOOL NO. BRF2E
PRICE EACH — \$40.00

REPLACEMENT PART

Part No.	Description	Price
SS1032-516	Set Screw for BRF1	.30

Replacement parts for Resizing Fixture and arbors are available. Please inquire

RESHARPENING FIXTURE

TOOL NO. BRF1
PRICE EACH — \$19.50

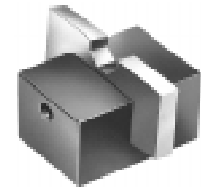

The Resharpener Fixture accommodates all blade diameters and thicknesses. The correct end tooth relief angle is built into the fixture making resharpener simple, accurate, and inexpensive on any surface grinder.



PILOTED HOLDERS-MACHINE TOOL

Select from a wide variety of blade holders for use in all types of hole making equipment. Below you find examples of the different types of equipment the Multi - tool Piloted Holders can be utilized in.

THE MULTI -TOOL SYSTEM CHANGES THE WAY YOU LOOK AT HOLE MAKING!

USE WITH BRIDGEPORT® TYPE MILLING MACHINES

5/8" Shank 21/32" Pilot
"D" Series **DH20**



Straight Shank
3/4" – "D" Series **DH23**
and 1" – "E" Series **EH32**



3/4" Reduced Shank
15/16" Pilot **EH30** and 1-1/16" Pilot **EH34**
"E" Series



R-8 Bridgeport Shank
"D" Series **DHR8** and "E" Series **EHR8**



USE WITH LATHES AND TURNING CENTERS

5/8" Shank 21/32" Pilot
"D" Series **DH20**



Lathe Shank w/Flats
(Mounts in tool post so power feed can be utilized)
3/4" – "D" Series **DHS23**
and 1" – "E" Series **EHS32**



Morse Taper Shank
No. 2 – "D" Series **DH2T**
No. 3 **EH3T** and No. 4 **EH4T**
"E" Series*



3/4" Shank 13/16" Pilot
"D" Series **DH24**



USE WITH MAG DRILL

1/2" Reduced Shank
with 3 Equal Flats
"D" Series **DH1** and "E" Series **EH1**



5/8" Shank 21/32" Pilot
"D" Series **DH20**



3/4" Reduced Shank
15/16" Pilot **EH30** and 1-1/16" Pilot **EH34**
"E" Series



Morse Taper Shank
No. 2 – "D" Series **DH2T**
No. 3 **EH3T** and No. 4 **EH4T**
"E" Series*



REFERENCE CHART



*No. 3 and No. 4 Morse Taper "E" Series Shanks are also available with long and extra long reach.

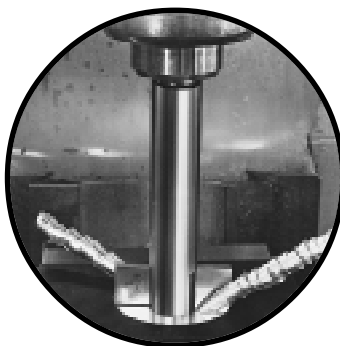

A WIDE RANGE OF SHANK STYLES FOR EASY ADAPTABILITY THROUGHOUT ANY MACHINE SHOP!

USE WITH DRILL MILL

1/2" Reduced Shank with 3 Equal Flats
"D" Series **DH1** and "E" Series **EH1**



USE WITH DRILL PRESS

3/4" Reduced Shank
15/16" Pilot **EH30** and 1-1/16" Pilot **EH34**
"E" Series



USE WITH CNC MACHINING CENTER

Straight Shank
3/4" – "D" Series **DH23**
and 1" – "E" Series **EH32**



5/8" Shank 21/32" Pilot
"D" Series **DH20**



1/2" Reduced Shank with 3 Equal Flats
"D" Series **DH1** and "E" Series **EH1**



3/4" Reduced Shank
15/16" Pilot **EH30** and 1-1/16" Pilot **EH34**
"E" Series



3/4" Reduced Shank
15/16" Pilot **EH30** and 1-1/16" Pilot **EH34**
"E" Series



5/8" Shank 21/32" Pilot
"D" Series **DH20**



USE WITH RADIAL DRILL

Straight Shank
3/4" – "D" Series **DH23**
and 1" – "E" Series **EH32**



3/4" Shank 13/16" Pilot
"D" Series **DH24**



Morse Taper Shank
No. 2 – "D" Series **DH2T**
No. 3 **EH3T** and No. 4 **EH4T**
"E" Series*



Morse Taper Shank
No. 2 – "D" Series **DH2T**
No. 3 **EH3T** and No. 4 **EH4T**
"E" Series*

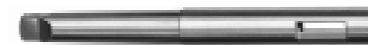

THE MULTI-TOOL SYSTEM

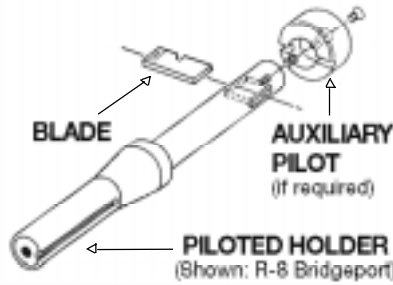

◆ "D" PILOTED HOLDERS

1/2" Reduced Shank w/ 3 Equal Flats DH1



5/8" Diameter Shank*- 21/32" Pilot DH20



3/4" Lathe Shank w/ 4 (5/8") Sq. Flats** DHS23



3/4" Straight Shank DH23



3/4" Diameter Shank*- 13/16" Pilot DH24



No. 2 Morse Taper Shank DH2T



R-8 Bridgeport Shank DHR8



◆ STANDARD BLADES

D Series – 3/16" Thick High Speed Steel

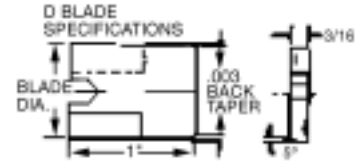

From 1-17/32" — 2" Auxiliary Pilot DX15 Required
From 2-1/32" — 2-1/2" Auxiliary Pilot DX20 Required

BLADE DIA.	TOOL NO.	PRICE EACH	BLADE DIA.	TOOL NO.	PRICE EACH	BLADE DIA.	TOOL NO.	PRICE EACH
7/8	DB28	17.08	1-5/16	DB42	20.40	1-27/32	DB59	24.01
29/32	DB29	17.25	1-11/32	DB43	20.64	1-7/8	DB60	24.01
15/16	DB30	17.25	1-3/8	DB44	20.64	1-29/32	DB61	24.73
31/32	DB31	18.11	1-13/32	DB45	20.99	1-15/16	DB62	24.73
63/64	DB315	18.11	1-7/16	DB46	20.99	1-31/32	DB63	25.07
1	DB32	18.11	1-15/32	DB47	21.40	2	DB64	25.07
1-1/64	DB325	18.63	1-31/64	DB475	21.39	2-1/32	DB65	26.25
1-1/32	DB33	18.63	1-1/2	DB48	21.39	2-1/16	DB66	26.25
1-3/64	DB335	18.63	1-17/32	DB49	21.80	2-3/32	DB67	27.49
1-1/16	DB34	18.63	1-9/16	DB50	21.80	2-1/8	DB68	27.49
1-3/32	DB35	18.98	1-19/32	DB51	22.29	2-5/32	DB69	28.36
1-7/64	DB355	18.98	1-5/8	DB52	22.29	2-3/16	DB70	28.36
1-1/8	DB36	18.98	1-21/32	DB53	22.70	2-7/32	DB71	28.72
1-9/64	DB365	19.44	1-11/16	DB54	22.70	2-1/4	DB72	28.72
1-5/32	DB37	19.44	1-23/32	DB55	22.96	2-5/16	DB74	29.33
1-3/16	DB38	19.44	1-47/64	DB555	22.96	2-3/8	DB76	30.13
1-7/32	DB39	19.84	1-3/4	DB56	22.96	2-7/16	DB78	31.05
1-1/4	DB40	19.84	1-25/32	DB57	23.23	2-1/2	DB80	31.86
1-9/32	DB41	20.40	1-13/16	DB58	23.23	-	-	-

◆ AUXILIARY PILOTS

D Series Standard Duty

For Producing Holes in Steel Larger than 1-1/2" in Diameter



DIAMETER	BLADE DIA. RANGE	TOOL NO.	PRICE EACH
1-1/2"	1-17/32" – 2"	DX15	21.00
2"	2-1/32" – 2-1/2"	DX20	22.99

◆ "D" SERIES OPERATING INSTRUCTIONS

With the use of auxiliary pilots, holes may be drilled up to 2-1/2" diameters in steel while maintaining optimum rigidity with low horsepower.

Step 1 Drill first pilot hole with a conventional 3/4" twist drill or the 3/4" Multi-Tool threaded pilot drill.

Step 2 For Finish Hole 1-1/2" or Less

Insert finish size blade into piloted holder and drill hole to size.

For Finish Hole Over 1-1/2" to 2"

Insert 1-1/2" blade in piloted holder and enlarge hole to 1-1/2". Next, insert finish size blade into holder, attach 1-1/2" auxiliary pilot and drill hole to size.

For Finish Hole Over 2"

Insert 1-1/2" blade in piloted holder and enlarge hole to 1-1/2". Next, insert 2" blade in piloted holder, attach 1-1/2" auxiliary pilot, and enlarge hole to 2". Finally, insert finish size blade into holder, attach 2" auxiliary pilot and drill hole to size.

Note: When drilling certain *non-ferrous* metals, it may be possible to drill up to a 2-1/2" hole in one pass without the use of one or both auxiliary pilots.

Cutting fluids are always required when machining metals (except for cast iron) for safe operation and longer tool life. Select the appropriate fluid for the material to be machined.

Select the same cutting speeds and feed rates as you would for drills of same size.

SHANK STYLE	PILOT DIA.	OAL	DEPTH OF CUT	TOOL NO.	PRICE EACH
1/2" Reduced Shank	3/4"	6"	4"	DH1	56.35
5/8" Dia.* - 21/32" Pilot	21/32	7-1/2	5-1/4	DH20	48.88
3/4" Lathe Shk. w/sq flats**	3/4	7-1/2	5-1/4	DHS23	68.48
3/4" Straight Shank	3/4	7-1/2	5-1/4	DH23	55.20
3/4" Shank*-13/16" Pilot	13/16	7-1/2	5-1/4	DH24	68.48
#2 M.T. Shank	3/4	7-1/2	4-3/8	DH2T	60.54
R-8 Bridgeport Shank	3/4	8-1/4	4	DHR8	97.75

Note: *DH20 and DH24 are not offered in 3/4" pilot diameter and cannot be used with pilot drill or auxiliary pilot.
**DHS23 is designed for use in tool post with power feed

◆ PILOT DRILLS



2" Flute Length – 2-3/4" OAL
3/4 Dia. – 118° Point
5/16-24 Thread
Two flats on drill barrel for easy removal

HIGH SPEED STEEL
This threaded shank drill was specially designed for the Multi-Tool piloted holder. It allows single-positioning, one pass operations.

TOOL NUMBER – DBP34
PRICE EACH – \$51.75

◆ REPLACEMENT PARTS

SS51624-38	Set Screw for "D" Series Holders	.50
CF51624-58	Auxiliary Pilot Screw for "D" Series	.50

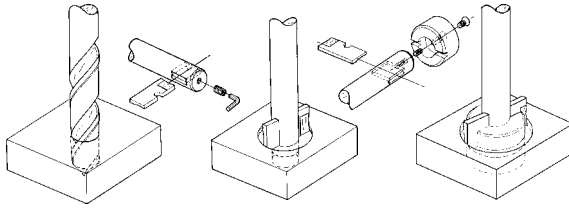

Drill Pilot Hole With Pilot Drill or Conventional Twist Drill

Insert Blade For Drilling Without Auxiliary Pilot

Insert Blade & Attach Auxiliary Pilot For Larger Diameter Hole

HEAVY DUTY BLADES

E Series – 1/4" Thick High Speed Steel or Cobalt

From 2-1/16" — 2-1/2" Auxiliary Pilot EX20 Required
From 2-9/16" — 4" Auxiliary Pilot EX25 Required

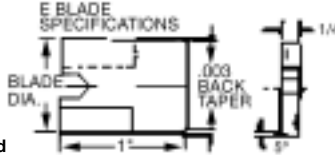

BLADE DIA.	HIGH SPEED STEEL		COBALT		BLADE DIA.	HIGH SPEED STEEL		COBALT	
	TOOL NO.	PRICE EACH	TOOL NO.	PRICE EACH		TOOL NO.	PRICE EACH	TOOL NO.	PRICE EACH
1-1/8	EB36	19.55	CEB36	29.33	2-5/16	EB74	31.68	CEB74	47.38
1-5/32	EB37	20.59	-	-	2-3/8	EB76	32.49	CEB76	48.88
1-3/16	EB38	20.59	CEB38	30.59	2-7/16	EB78	33.35	-	-
1-7/32	EB39	21.28	-	-	2-1/2	EB80	34.21	CEB80	51.41
1-1/4	EB40	21.28	CEB40	30.79	2-9/16	EB82	34.66	CEB82	52.34
1-5/16	EB42	21.97	CEB42	31.34	2-5/8	EB84	35.13	CEB84	53.20
1-3/8	EB44	21.97	CEB44	31.63	2-11/16	EB86	35.88	-	-
1-7/16	EB46	22.86	CEB46	31.91	2-3/4	EB88	36.63	CEB88	55.43
1-1/2	EB48	23.69	CEB48	32.18	2-13/16	EB90	37.12	-	-
1-9/16	EB50	24.35	CEB50	33.12	2-7/8	EB92	37.93	CEB92	57.39
1-5/8	EB52	24.91	CEB52	34.24	2-15/16	EB94	38.87	-	-
1-11/16	EB54	25.24	CEB54	35.37	3	EB96	39.73	CEB96	59.92
1-3/4	EB56	25.62	CEB56	36.57	3-1/16	EB98	41.29	-	-
1-13/16	EB58	26.29	CEB58	37.94	3-1/8	EB100	42.21	-	-
1-7/8	EB60	26.91	CEB60	39.33	3-1/4	EB104	43.13	-	-
1-15/16	EB62	27.37	CEB62	40.83	3-3/8	EB106	44.62	-	-
2	EB64	28.00	CEB64	42.26	3-1/2	EB112	45.94	CEB112	69.58
2-1/16	EB66	25.52	CEB66	43.13	3-5/8	EB116	47.78	-	-
2-1/8	EB68	29.04	CEB68	44.08	3-3/4	EB120	49.19	-	-
2-3/16	EB70	30.48	CEB70	45.14	3-7/8	EB124	50.31	-	-
2-1/4	EB72	30.99	CEB72	45.89	4	EB128	51.58	CEB128	77.91

AUXILIARY PILOTS

E Series Heavy Duty

For Producing Holes in Steel Larger than 2" in Diameter



DIAMETER	BLADE DIA. RANGE	TOOL NO.	PRICE EACH
2	2-1/16 – 2-1/2	EX20	22.99
2-1/2	2-9/16 – 3-1/2	EX25	24.99

"E" SERIES OPERATING INSTRUCTIONS

With the use of auxiliary pilots, holes may be drilled up to 3" diameters in steel and up to 4" diameters in non-ferrous material while maintaining optimum rigidity with low horsepower.

Step 1 Drill first pilot hole with a conventional 1" twist drill or the 1" Multi-Tool threaded pilot drill.

Step 2 For Finish Hole 2" or Less
Insert finish size blade into piloted holder and drill hole to size.

For Finish Hole Over 2" to 2-1/2"

Insert 2" blade in piloted holder and enlarge hole to 2". Next, insert finish size blade into holder, attach 2" auxiliary pilot and drill hole to size.

For Finish Hole Over 2-1/2"

Insert 2" blade in piloted holder and enlarge hole to 2". Next, insert 2-1/2" blade in piloted holder, attach 2" auxiliary pilot, and enlarge hole to 2-1/2". Finally, insert finish size blade into holder, attach 2-1/2" auxiliary pilot and drill hole to size.

Note: When drilling certain *non-ferrous* metals, it may be possible to drill up to a 4" hole in one pass without the use of one or both auxiliary pilots.
Cutting fluids are always required when machining metals (except for cast iron) for safe operation and longer tool life. Select the appropriate fluid for the material to be machined.
Select the same cutting speeds and feed rates as you would for drills of same size.

"E" PILOTED HOLDERS

1/2" Reduced Shank w/ 3 Equal Flats EH1



3/4" Reduced Shank * 15/16" Pilot EH30



3/4" Reduced Shank * 1-1/16" Pilot EH34



1" Lathe Shank w/4 (7/8") Sq. Flats ** EHS32



1" Straight Shank Regular Length EH32
Long Length EH32L
Ex. Long Length EH32XL



#3 Morse Taper Shank Regular Length EH3T
Long Length EH3TL
Ex. Long Length EH3TXL

#4 Morse Taper Shank Regular Length EH4T
Long Length EH4TL
Ex. Long Length EH4TXL



R-8 Bridgeport Shank EHR8



SHANK STYLE	PILOT DIA.	OAL	DEPTH OF CUT	TOOL NO.	PRICE EACH
1/2" Reduced Shank	1	6	4	EH1	88.49
3/4" Dia. Reduced Shank*	15/16	8	5-3/4	EH30	88.72
3/4" Dia. Reduced Shank*	1-1/16	8	5-3/4	EH34	94.59
1" Lathe Shank w/Sq Flats**	1	10	7-3/4	EHS32	88.72
1" Straight Shank Reg.	1	10	7-3/4	EH32	72.16
1" Straight Shank Long	1	16	12	EH32L	123.86
1" Straight Shank Ex. Long	1	22	18	EH32XL	212.35
#3 M.T. Shank Reg.	1	10	6	EH3T	75.79
#3 M.T. Shank Long	1	16	12	EH3TL	132.83
#3 M.T. Shank Ex. Long	1	22	18	EH3TXL	226.95
#4 M.T. Shank Reg.	1	11	6	EH4T	108.75
#4 M.T. Shank Long	1	17	12	EH4TL	155.42
#4 M.T. Shank Ex. Long	1	23	18	EH4TXL	256.45
R-8 Bridgeport Shank	1	9-1/4	5	EHR8	103.21

Note: * EH30 and EH34 are not offered in 1" Pilot Diameter and cannot be used with pilot drill or auxiliary pilot.
** EHS32 is designed for use in tool post with power feed.

PILOT DRILLS

HIGH SPEED STEEL

This threaded shank drill was specially designed for the Multi-Tool piloted holder. It allows single-positioning, one pass operations.



2-1/4" Flute Length – 3" OAL
118° Point – 1/2-20 Thread
Two flats on drill barrel for easy removal

TOOL NUMBER – EBP10
PRICE EACH – \$56.93

REPLACEMENT PARTS

SS1220-12	Set Screw for "E" Series Holders	.90
CF1220-34	Auxiliary Pilot Screw for "E" Series	.90



♦ MULTI-TOOL BLADES

INDEXABLE CARBIDE BLADES

The Multi -Tool System offers you these indexable carbide blades for heavy duty applications where higher surface speeds are needed and longer tool life is desired.

FIXED DIAMETER BLADE

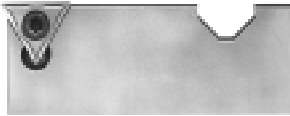

FIXED DIAMETER BLADES ARE PRIMARILY FOR USE IN 1" LATHE SHANK WITH FOUR SQUARE FLATS. (EHS32)

May be run at higher surface speeds than high speed steel blades. When the cutting edge becomes dull, a new cutting edge can be indexed without removing the blade from the holder.

A		B		Auxiliary Pilot Required	Blade No. A or B	Price Each
Hole diameter produced when using TPGH-321 (1/64" radius inserts)		Hole diameter produced when using TPGH-322 (1/32" radius inserts)				
1-7/8		1-27/32		—	EBC60	28.75
2		1-31/32		—	EBC64	30.82
2-1/8		2-3/32		EX20	EBC68	31.63
2-1/4		2-7/32		EX20	EBC72	33.35
2-3/8		2-11/32		EX20	EBC76	34.39
2-1/2		2-15/32		EX20	EBC80	37.03
2-5/8		2-19/32		EX25	EBC84	37.69
2-3/4		2-23/32		EX25	EBC88	39.68
2-7/8		2-27/32		EX25	EBC92	41.23
3		2-31/32		EX25	EBC96	43.59

ADJUSTABLE DIAMETER BLADE



ADJUSTABLE DIAMETER BLADES ARE PRIMARILY FOR USE IN 1" LATHE SHANK WITH FOUR SQUARE FLATS (EHS32)

By positioning the blade to the cutting diameter required, you can transform the MULTI-TOOL into an adjustable single point cutting tool or boring bar. Simply loosen the locking screw in the piloted holder, then adjust the blade to desired diameter from 2" to 3-1/4". Once the size has been set using an indicator or micrometer gauge, the inserts can be easily indexed or changed without losing size!

Blade Cutting Range	Auxiliary Pilot Required	Blade No.	Price Each
2 — 2-3/4	EX20	EBC200	37.95
2 -1/2 — 3-1/4	EX25	EBC250	48.30

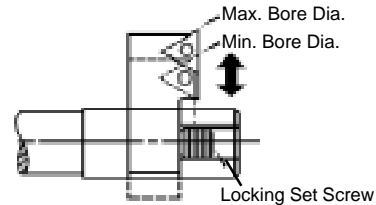

Insert No.	Radius	I.C.	Thickness	Price Each		
				C-2	C-5 & C-6	TiN Coated*
TPGH321	1/64	3/8	1/8	5.13	5.70	6.95
TPGH322	1/32	3/8	1/8	5.13	5.70	6.95

*C-5 & C-6 Grade TiN Coated

REPLACEMENT PARTS LIST		
Part No.	Description	Price Each
TF832-285	Torx® Drive Flat Head Screw	1.75
CTW-10	Torx® Wrench	2.45

S-TYPE BLADES FOR 3-1/2" TO 6-1/4" DIAMETER HOLES

- High Speed Steel
- Can be used on low horsepower portable magnetic or fixed machine drilling
- Effective in steel up to 1/2" Thick (up to 1" if cut from both sides)
- Adjust to uneven work surfaces and small misalignments



The S-Type Blade is held with a special spring loaded set screw, producing a floating action which adjusts to uneven work surfaces or small misalignments between spindle and workpiece.

If depth of cut is greater than 1/2", advance piloted holder through the pilot hole and insert blade in an upward orientation. Reverse spindle and feed in upward cutting direction to maximum blade depth.

Remove blade, withdraw piloted holder and reinsert blade in downward cutting position with right hand rotation and complete cut to break through.

NOT RECOMMENDED FOR USE IN FLATTED LATHE PILOTTED HOLDERS.

Blade Dia.	Blade No.	Price Each	Blade Dia.	Blade No.	Price Each
3-1/2	EBS112	61.53	5-1/4	EBS168	102.93
3-3/4	EBS120	66.70	5-1/2	EBS176	109.25
4	EBS128	73.31	5-3/4	EBS184	114.14
4-1/2	EBS144	85.10	6	EBS192	122.40
4-3/4	EBS152	91.77	6-1/4	EBS200	128.80
5	EBS160	97.75			

SET SCREW
Must be used with S-Type Blade for proper operation.
PART NO. SS1
PRICE \$8.80



♦ MULTI-TOOL BLADES



COMBINATION BLADES

Uses same auxiliary pilots as standard blades

FOR FORWARD AND BACKWARD CUTTING

PATENTED

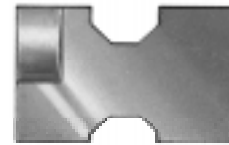
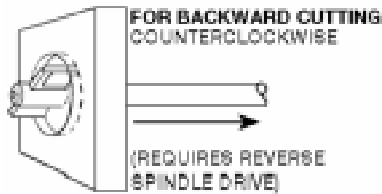

- Available in High Speed Steel
- For Standard Cap Screws
- Allows more chip clearance
- For use in confined areas
- Can be modified for special configurations
- With the same piloted holder you can forward counterbore, back counterbore and spotface

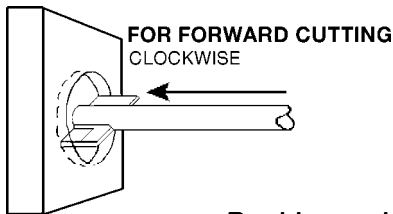

NOTE: Select the same cutting speeds and feed rates as you would for drills of the same size. When ordering, use standard blade number for size and add a suffix of "DN" to indicate blade style.

Double notched prices: add \$5.50 to standard D Series H.S. blade prices and \$6.50 to standard E Series H.S. blade prices.

STANDARD BLADE PROFILES

90° CHAMFERING BLADES

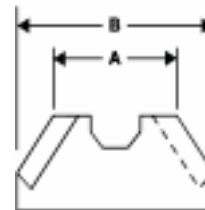

These blades are used to chamfer holes from 1" to 4-3/8" in diameter. When used in the same set up and holder which produced the hole, close concentricity can be achieved. [Please inquire](#)

E-SERIES CHAMFERING RANGE			
TOOL NO.	Range of Diameter Which Can Be Cut		PRICE EACH
	Smallest Dia. to Largest Dia.		
	A	B	
EBA44	1	1-3/8	25.73
EBA56	1-3/8	1-3/4	27.02
EBA68	1-3/4	2-1/8	28.73
EBA80	2-1/8	2-1/2	33.04
EBA92	2-1/2	2-7/8	38.00
EBA104	2-7/8	3-1/4	43.70
EBA116	3-1/4	3-5/8	48.07
EBA128	3-5/8	4	52.88
EBA140	4	4-3/8	58.16

D-SERIES CHAMFERING RANGE			
TOOL NO.	Range of Diameter Which Can Be Cut		PRICE EACH
	Smallest Dia. to Largest Dia.		
	A	B	
DBA36	3/4	1-1/8	19.97
DBA44	1	1-3/8	21.97
DBA56	1-3/8	1-3/4	24.16
DBA68	1-3/4	2-1/8	26.58
DBA80	2-1/8	2-1/2	29.23
DBA92	2-1/2	2-7/8	32.16

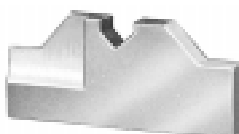

SPECIAL ORDER MULTI-DIAMETER AND CHAMFERING BLADES

Do you have a job with unique specifications?
Counterbore profiles may be special ordered to your print.
[Please inquire.](#)



♦ MULTI-TOOL SETS

STANDARD DUTY “D” SERIES



Shown:
1/2" Reduced Shank Set

1/2" REDUCED SHANK SET

Contains 1 piece of each:

- DH1-3/4" Piloted Holder, 1/2" Shank
- 3/4" H.S. Silver and Deming 1/2" Shank Drill
- #6 Combination Drill and Countersink (Above tools are 6" overall for quick single set up)
- 5/32" Hex Wrench
- High Speed Steel D Series Blades - 1 each of: 1-1/4", 1-1/16", 1-1/8", 1-3/16", 1-1/4", 1-5/16", 1-3/8", 1-7/16", 1-1/2"

SET NO. DS1 — SET PRICE \$339.00

Set with chamfering blades:

SET NO. DS1A — SET PRICE \$360.00

R-8 SHANK SET

Contains 1 piece of each:

- DHR8 - 3/4" Piloted Holder, R-8 Shank
- 3/4" High Speed Twist Drill, Straight Shank
- DX15 - 1-1/2" Auxiliary Pilot
- DX20 - 2" Auxiliary Pilot
- Hex Wrench
- High Speed Steel D Series Blades - 1 each of: 1-1/4", 1-5/16", 1-3/8", 1-1/2", 1-5/8", 1-3/4", 1-7/8", 2", 2-1/8", 2-1/4", 2-3/8", 2-1/2"

SET NO. DS7 — SET PRICE \$459.00

Set with chamfering blades:

SET NO. DS7A — SET PRICE \$499.00



Shown:
Straight Shank Set

STRAIGHT SHANK SET

Contains 1 piece of each:

- DH23-3/4" Piloted Holder, Straight Shank
- 3/4" High Speed Twist Drill, Straight Shank
- DX15 - 1-1/2" Auxiliary Pilot
- DX20 - 2" Auxiliary Pilot
- 5/32" and 3/16" Hex Wrenches
- High Speed Steel D Series Blades - 1 each of: 1-1/4", 1-5/16", 1-3/8", 1-1/2", 1-5/8", 1-3/4", 1-7/8", 2", 2-1/8", 2-1/4", 2-3/8", 2-1/2"

SET NO. DS2 — SET PRICE \$419.00

Set with chamfering blades:

SET NO. DS2A — SET PRICE \$465.00

TAPER SHANK SET

Contains 1 piece of each:

- DH2T- 3/4" Piloted Holder, #2 M.T. Shank
- 3/4" High Speed Twist Drill, #2 M.T. Shank
- DX15 - 1-1/2" Auxiliary Pilot
- DX20 - 2" Auxiliary Pilot
- 5/32" and 3/16" Hex Wrenches
- High Speed Steel D Series Blades - 1 each of: 1-1/4", 1-5/16", 1-3/8", 1-1/2", 1-5/8", 1-3/4", 1-7/8", 2", 2-1/8", 2-1/4", 2-3/8", 2-1/2"

SET NO. DS3 — SET PRICE \$429.00

Set with chamfering blades:

SET NO. DS3A — SET PRICE \$475.00

HEAVY DUTY “E” SERIES

STRAIGHT SHANK SET

HIGH SPEED OR COBALT BLADES

Contains 1 piece of each:

- EH32 - 1" Piloted Holder, Straight Shank
- 1" High Speed Twist Drill, Straight Shank
- EX20 - 2" Auxiliary Pilot
- EX25 - 2-1/2" Auxiliary Pilot
- 1/4" and 5/16" Hex Wrenches
- E Series Blades - 1 each of: 1-1/4", 1-3/8", 1-1/2", 1-5/8", 1-3/4", 2", 2-1/4", 2-1/2", 2-3/4", 3"

HIGH SPEED SET NO. ES4 — SET PRICE \$477.00

COBALT SET NO. ESC4 — SET PRICE \$609.00

Set with chamfering blades:

SET NO. ES5A — SET PRICE \$565.00

1/2" REDUCED SHANK SET

HIGH SPEED OR COBALT BLADES

Contains 1 piece of each:

- EH1-1" Piloted Holder, 1/2" Shank
- 1" High Speed Silver and Deming 1/2" Shank
- #6 Combination Drill and Countersink (Above tools are 6" overall for quick, single set up)
- 1/4" and 5/16" Hex Wrenches
- E Series Blades - 1 each of: 1-1/8", 1-3/16", 1-1/4", 1-5/16", 1-3/8", 1-7/16", 1-1/2", 1-5/8", 1-3/4", 1-7/8", 2"

HIGH SPEED SET NO. ES1 — SET PRICE \$454.00

COBALT SET NO. ESC1 — SET PRICE \$569.00

Set with chamfering blades:

SET NO. ES4A — SET PRICE \$565.00



Shown:
Taper Shank Set

TAPER SHANK SET

HIGH SPEED OR COBALT BLADES

Contains 1 piece of each:

- EH3T - 1" Piloted Holder, #3 M.T. Shank
- 1" High Speed Twist Drill, #3 M.T. Shank
- EX20 - 2" Auxiliary Pilot
- EX25 - 2-1/2" Auxiliary Pilot
- 1/4" and 5/16" Hex Wrenches
- E Series Blades - 1 each of: 1-1/4", 1-3/8", 1-1/2", 1-5/8", 1-3/4", 2", 2-1/4", 2-1/2", 2-3/4", 3"

HIGH SPEED SET NO. ES5 — SET PRICE \$477.00

COBALT SET NO. ESC5 — SET PRICE \$609.00

Set with chamfering blades:

SET NO. ES8A — SET PRICE \$579.00

R-8 SHANK SET

HIGH SPEED OR COBALT BLADES

Contains 1 piece of each:

- EHR8 - 1" Piloted Holder, R-8 Shank
- 1" High Speed Twist Drill, Straight Shank
- EX20 - 2" Auxiliary Pilot
- EX25 - 2-1/2" Auxiliary Pilot
- 1/4" and 5/16" Hex Wrenches
- E Series Blades - 1 each of: 1-1/4", 1-3/8", 1-1/2", 1-5/8", 1-3/4", 2", 2-1/4", 2-1/2", 2-3/4", 3"

HIGH SPEED SET NO. ES9 — SET PRICE \$509.00

COBALT SET NO. ESC9 — SET PRICE \$638.00

Set with chamfering blades:

SET NO. ES9A — SET PRICE \$595.00

◆ CAP SCREW COUNTERBORES

PATENTED



USES THE SAME SIMPLE DESIGN OF THE MULTI-TOOL SYSTEM

Designed to counterbore holes for standard cap screws. Using the same piloted holder, you can forward counterbore, back counterbore, and spotface. Just choose the appropriate blade for your application.

OPERATION

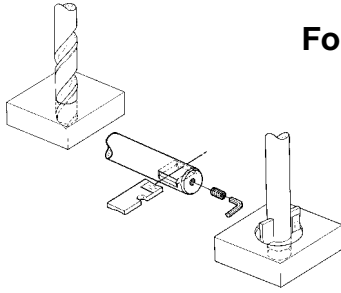

For Forward and Backward Applications

- STEP 1** Select the appropriate piloted holder and blade for the screw size needed.
- STEP 2** Insert the blade into the piloted holder and tighten the set screw.
- A) Forward counterboring- use in a clockwise direction
 B) Backward counterboring- use in a reverse spindle, counter-clockwise direction.

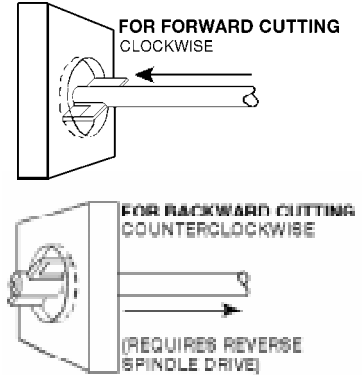

HIGH SPEED STEEL BLADES

- Back Counterbore • Spotface • Forward Counterbore
- Resharpen and modify blades to special diameters and unusual hole configurations
- Worn blades can be ground to smaller diameters and reused

FORWARD BLADES

SCREW SIZE	CUTTING DIAMETER	BLADE THICKNESS	BLADE NUMBER	PRICE EACH
No.10	21/64	1/16	AB216	11.21
1/4	13/32	1/16	AB13	11.44
5/16	1/2	3/32	BB16	14.38
3/8	19/32	3/32	BB19	15.87
7/16	11/16	3/32	BB22	17.08
1/2	25/32	3/32	BB25	17.83
5/8	1	3/16	DB32	18.11
3/4	1-3/16	3/16	DB38	19.44
7/8	1-3/8	1/4	EB44	22.54
1	1-9/16	1/4	EB50	24.35

BACKWARD BLADES

SCREW SIZE	CUTTING DIAMETER	BLADE THICKNESS	BLADE NUMBER	PRICE EACH
1/4	13/32	1/16	ABZ13	13.63
5/16	1/2	3/32	BBZ16	17.14
3/8	19/32	3/32	BBZ19	20.13
7/16	11/16	3/32	BBZ22	20.59
1/2	25/32	3/32	BBZ25	21.28
5/8	1	3/16	DBZ32	21.74
3/4	1-3/16	3/16	DBZ38	22.94
7/8	1-3/8	1/4	EBZ44	26.65
1	1-9/16	1/4	EBZ50	29.21

NOTE: Select the same cutting speeds and feed rates as you would for drills of same size.

COUNTERBORE SETS

FORWARD SET

SET NO. AB1

10 piece set contains 1 piece each Blade and piloted holder for the following screw sizes:
 No. 10, 1/4, 5/16, 3/8, 1/2
 supplied in wood block
SET PRICE — \$189.00

BACKWARD SET

SET NO. AB2

10 piece set contains 1 piece each Blade and piloted holder (reverse spindle required)
 1/4, 5/16, 3/8, 7/16, 1/2
 supplied in wood block
SET PRICE — \$215.00

NOTE: Blades of similar thickness may be used in any piloted holder which accommodates that thickness.

REPLACEMENT PARTS

PART NO.	DESCRIPTION	PRICE EACH
SS540-14	Set Screw for AH8 and 9	.50
SS832-516	Set Screw for BH11, 13, 15, and 16	.50
SS51624-38	Set Screw for DH20 and 24	.50
SS1220-12	Set Screw for EH30 and 34	.90

PILOTED HOLDERS

SCREW SIZE	PILOT DIAMETER	SHANK DIAMETER	OVERALL LENGTH	TOOL NUMBER	PRICE EACH
10	13/64	1/4	4	AH8	20.59
1/4	9/32	9/32	4	AH9	22.43
5/16	11/32	11/32	4-3/8	BH11	24.15
3/8	13/32	13/32	5	BH13	25.30
7/16	15/32	15/32	5-3/4	BH15	27.25
1/2	17/32	1/2	5-3/4	BH16	28.75
5/8	21/32	5/8	7-1/2	DH20	48.88
3/4	13/16	3/4	7-1/2	DH24	68.48
7/8	15/16	3/4	8	EH30	88.72
1	1-1/16	3/4	8	EH34	94.59



MADE IN U.S.A.— EXCLUSIVELY BY A.P.T.

■ SUPER-BORE CARBIDE TIPPED BORING BARS

• HIGH QUALITY ALLOY STEEL FOR GREATER RIGIDITY

• PRECISION GROUND SHANKS

• OFFSET TAPER TO PROVIDE GREATER RIGIDITY AT CUTTING POINT

3/8" SHANK				
Min. Bore	Bore Depth	Overall Length	Tool No.	Price Each
5/16	3/4	2	PA5S	10.29
5/16	1-1/8	2-3/8	PA5M	10.75
5/16	1-1/2	2-3/4	PA5L	11.21
3/8	15/16	2-3/16	PA3S	11.44
3/8	1-13/32	2-21/32	PA3M	11.79
3/8	1-7/8	3-1/8	PA3L	12.59
7/16	1-1/8	2-3/8	PA7S	12.88
7/16	1-11/16	3-15/16	PA7M	13.11
7/16	2-1/4	3-1/2	PA7L	13.74

1/2" SHANK				
Min. Bore	Bore Depth	Overall Length	Tool No.	Price Each
5/16	3/4	2-1/4	PB5S	13.74
5/16	1-1/8	2-5/8	PB5M	14.09
5/16	1-1/2	3	PB5L	14.72
7/16	1-1/8	2-5/8	PB7S	15.24
7/16	1-11/16	3-3/16	PB7M	15.87
7/16	2-1/4	3-3/4	PB7L	16.04
9/16	1-1/2	3	PB9S	16.50
9/16	2-1/4	3-3/4	PB9M	16.73
9/16	3	4-1/2	PB9L	17.08

5/8" SHANK				
Min. Bore	Bore Depth	Overall Length	Tool No.	Price Each
5/16	3/4	2-1/4	PC5S	17.23
5/16	1-1/8	2-5/8	PC5M	17.77
5/16	1-1/2	3	PC5L	18.69
7/16	1-1/8	2-5/8	PC7S	19.38
7/16	1-11/16	3-3/16	PC7M	20.18
7/16	2-1/4	3-3/4	PC7L	21.45
9/16	1-1/2	3	PC9S	21.85
9/16	2-1/4	3-3/4	PC9M	22.71
9/16	3	4-1/2	PC9L	23.75
11/16	1-7/8	3-3/8	PC11S	24.50
11/16	2-13/16	4-5/16	PC11M	25.43
11/16	3-3/4	5-1/4	PC11L	26.91

3/4" SHANK				
Min. Bore	Bore Depth	Overall Length	Tool No.	Price Each
7/16	1-1/8	3-1/8	PD7S	20.18
7/16	1-11/16	3-11/16	PD7M	21.22
7/16	2-1/4	4-1/4	PD7L	22.14
9/16	1-1/2	3-1/2	PD9S	22.89
9/16	2-1/4	4-1/4	PD9M	23.52
9/16	3	5	PD9L	24.55
11/16	1-7/8	3-7/8	PD11S	25.24
11/16	2-13/16	4-13/16	PD11M	26.05
11/16	3-3/4	5-3/4	PD11L	27.03
13/16	2-1/4	4-1/4	PD13S	28.64
13/16	3-3/8	5-3/8	PD13M	30.30
13/16	4-1/2	6-1/2	PD13L	31.97



Please specify grade when ordering
C-2 Cast Iron
or
C-6 Steel.

1" SHANK				
Min. Bore	Bore Depth	Overall Length	Tool No.	Price Each
7/16	1-3/4	3-3/4	PE7S	35.13
9/16	2-1/4	4-1/4	PE9S	37.66
9/16	3	5	PE9L	39.96
11/16	3	5	PE11S	39.96
11/16	3-3/4	5-3/4	PE11L	41.23
13/16	3-3/4	5-3/4	PE13L	41.23
7/8	4-1/2	6-1/2	PE14L	44.10
15/16	3-3/4	5-3/4	PE15S	45.89
1-1/16	4-1/2	6-1/2	PE17L	47.15
1-1/4	5-3/4	7-3/4	PE20L	50.60
1-1/2	6-1/4	8-1/4	PE24L	53.48
1-5/8	7-1/2	9-1/2	PE26L	57.44

3/8" SHANK

SET NO. PA375

9 Piece Set
Contains 1 Piece of Each:
3/8" Shank Boring
Bars Shown Above
SET PRICE — \$107.00

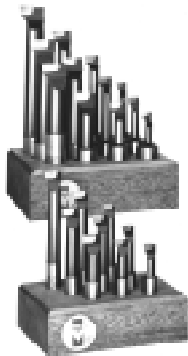

1/2" SHANK

SET NO. PB500

9 Piece Set
Contains 1 Piece of Each:
1/2" Shank Boring
Bars Shown Above
SET PRICE — \$137.00

SETS

ALL SETS ARE
SUPPLIED IN
WOOD STANDS

1" SHANK

SET NO. PE1000S

Standard Length
5 Piece Set
Contains 1 Piece
of Each:

1" Shank Boring Bars

PE7S, PE9S, PE11S, PE15S, PE17L
SET PRICE — \$205.00

SET NO. PE1000L

Long Length
5 Piece Set
Contains 1 Piece
of Each:

1" Shank Boring Bars

PE11L, PE17L, PE20L, PE24L, PE26L
SET PRICE — \$250.00

5/8" SHANK

SET NO. PC625

12 Piece Set
Contains 1 Piece of Each:
5/8" Shank Boring
Bars Shown Above
SET PRICE — \$259.00

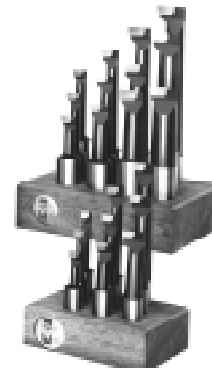

3/4" SHANK

SET NO. PD750

12 Piece Set
Contains 1 Piece of Each:
3/4" Shank Boring
Bars Shown Above
SET PRICE — \$304.00

◆ INDEXABLE BORING BARS



Boring bars come complete with insert screw and one C-5 grade insert

1/2" SHANK				
Min. Bore	Bore Depth	Overall Length	Tool No.	Price Each
7/16	1-1/4	2-3/4	NB7S	28.99
7/16	1-7/8	3-3/8	NB7M	28.99
7/16	2-1/2	4	NB7L	28.99
1/2	1-1/2	3	NB8S	31.99
1/2	2-1/8	3-5/8	NB8M	31.99
1/2	2-3/4	4-1/4	NB8L	31.99
9/16	1-3/4	3-1/4	NB9S	33.99
9/16	2-3/8	3-7/8	NB9M	33.99
9/16	3	4-1/2	NB9L	33.99

5/8" SHANK				
Min. Bore	Bore Depth	Overall Length	Tool No.	Price Each
7/16	1-1/4	3	NC7S	31.99
7/16	1-7/8	3-5/8	NC7M	31.99
7/16	2-1/2	4-1/4	NC7L	31.99
1/2	1-1/2	3-1/4	NC8S	32.99
1/2	2-1/8	3-7/8	NC8M	32.99
1/2	2-3/4	4-1/2	NC8L	32.99
9/16	1-3/4	3-1/2	NC9S	34.99
9/16	2-3/8	4-1/8	NC9M	34.99
9/16	3	4-3/4	NC9L	34.99
5/8	2	3-3/4	NC10S	36.99
5/8	2-5/8	4-3/8	NC10M	36.99
5/8	3-1/4	5	NC10L	36.99
11/16	2-1/4	4	NC11S	38.99
11/16	2-7/8	4-5/8	NC11M	38.99
11/16	3-1/2	5-1/4	NC11L	38.99

3/4" SHANK				
Min. Bore	Bore Depth	Overall Length	Tool No.	Price Each
7/16	1-1/4	3-1/4	ND7S	34.99
7/16	1-7/8	3-7/8	ND7M	34.99
7/16	2-1/2	4-1/2	ND7L	34.99
1/2	1-1/2	3-1/2	ND8S	35.99
1/2	2-1/8	4-1/8	ND8M	35.99
1/2	2-3/4	4-3/4	ND8L	35.99
9/16	1-3/4	3-3/4	ND9S	37.99
9/16	2-3/8	4-3/8	ND9M	37.99
9/16	3	5	ND9L	37.99
5/8	2	4	ND10S	38.99
5/8	2-5/8	4-5/8	ND10M	38.99
5/8	3-1/4	5-1/4	ND10L	38.99
11/16	2-1/4	4-1/4	ND11S	39.99
11/16	2-7/8	4-7/8	ND11M	39.99
11/16	3-1/2	5-1/2	ND11L	39.99
3/4	2-1/2	4-1/2	ND12S	40.09
3/4	3-1/4	5-1/4	ND12M	40.09
3/4	4	6	ND12L	40.09
13/16	2-3/4	4-3/4	ND13S	41.99
13/16	4	6	ND13M	41.99
13/16	4-1/2	6-1/2	ND13L	41.99

REPLACEMENT PARTS		
Part No.	Description	Price Each
TF440-195	Torx® drive flat head screw for 1/4" I.C.	1.25
CTW-6	Torx® Wrench –T6	1.95

SETS

Sets come complete with wrench in a wood stand.



1/2" SHANK
SET NO. ND500
 9 Piece Set
 Contains 1 Piece of Each:
 7/16 to 9/16
SET PRICE — \$279.00



5/8" SHANK
SET NO. ND625
 12 Piece Set
 Contains 1 Piece of Each:
 1/2 to 11/16
SET PRICE — \$419.00



3/4" SHANK
SET NO. ND750
 12 Piece Set
 Contains 1 Piece of Each:
 5/8 to 13/16
SET PRICE — \$479.00

Insert Number	Radius	I.C.	Thickness	Price Each		
				C-2	C-5 & C-6	TiN Coated
TPGH-21.50	0	1/4	3/32	4.75	5.23	6.11
TPGH-21.51	1/64	1/4	3/32	4.75	5.23	6.11
TPGH-21.52	1/32	1/4	3/32	4.75	5.23	6.11



TPGH

TRIANGLE — POSITIVE RAKE
 GROUND ALL OVER WITH
 CHIP GROOVE ON ONE SIDE

CARBIDE INSERTS



MADE IN U.S.A. — EXCLUSIVELY BY A.P.T.

◆ CO-BORE

PREMIUM *COBALT* BORING BARS AT HIGH SPEED PRICES!



Made of premium cobalt high speed steel in a one piece construction, these boring bars may also be modified to a special grooving tool to produce various internal shapes and radii. Cobalt is an ideal tool material because of its high red-hardness, abrasive resistance and ability to maintain a sharp edge. In addition, cobalt is used successfully to significantly extend tool life.

3/8" SHANK				
Min. Bore	Bore Depth	Overall Length	Tool No.	Price Each
3/16	9/16	1-13/16	COA3S	13.12
3/16	15/16	2-3/16	COA3L	13.90
1/4	3/4	2	COA4S	14.35
1/4	1-1/4	2-1/2	COA4L	15.04
5/16	15/16	2-3/16	COA5S	15.24
5/16	1-9/16	2-13/16	COA5L	16.00
3/8	1-1/8	2-3/8	COA6S	16.35
3/8	1-7/8	3-1/8	COA6L	17.14



SETS				
3/8" SHANK				
SET NO. COAH375				
Includes all 8 pieces shown at left. Supplied in wood block.				
SET PRICE — \$121.00				
1/2" SHANK				
SET NO. COBH500				
Includes all 10 pieces shown at right. Supplied in wood block.				
SET PRICE — \$187.00				
5/8" SHANK				
SET NO. COCH625				
Includes all 10 pieces shown at left. Supplied in wood block.				
SET PRICE — \$274.00				
3/4" SHANK				
SET NO. CODH750				
Includes all 14 pieces shown at right. Supplied in wood block.				
SET PRICE — \$436.00				

1/2" SHANK				
Min. Bore	Bore Depth	Overall Length	Tool No.	Price Each
1/4	3/4	2-1/8	COB4S	16.71
1/4	1-1/4	2-5/8	COB4L	17.14
5/16	15/16	2-5/16	COB5S	17.41
5/16	1-9/16	2-15/16	COB5L	18.19
3/8	1-1/8	2-1/2	COB6S	18.47
3/8	1-7/8	3-1/4	COB6L	19.17
7/16	1-5/16	2-11/16	COB7S	19.17
7/16	2-3/16	3-9/16	COB7L	19.67
1/2	1-1/2	2-7/8	COB8S	20.63
1/2	2-1/2	3-7/8	COB8L	21.09

5/8" SHANK				
Min. Bore	Bore Depth	Overall Length	Tool No.	Price Each
3/8	1-1/8	2-5/8	COC6S	21.85
3/8	1-7/8	3-3/8	COC6L	22.34
7/16	1-5/16	2-13/16	COC7S	23.51
7/16	2-13/16	3-11/16	COC7L	25.45
1/2	1-1/2	3	COC8S	26.12
1/2	2-1/2	4	COC8L	27.91
9/16	1-11/16	3-3/16	COC9S	29.80
9/16	2-13/16	4-5/16	COC9L	31.12
5/8	1-7/8	3-3/8	COC10S	32.65
5/8	3-1/8	4-5/8	COC10L	33.95

3/4" SHANK				
Min. Bore	Bore Depth	Overall Length	Tool No.	Price Each
3/8	1-1/8	2-7/8	COD6S	25.61
3/8	1-7/8	3-5/8	COD6L	26.52
7/16	1-5/16	3-1/16	COD7S	27.20
7/16	2-3/16	3-15/16	COD7L	28.45
1/2	1-1/2	3-1/4	COD8S	29.29
1/2	2-1/2	4-1/4	COD8L	30.06
9/16	1-11/16	3-7/16	COD9S	30.64
9/16	2-13/16	4-9/16	COD9L	31.81
5/8	1-7/8	3-5/8	COD10S	32.48
5/8	3-1/8	4-7/8	COD10L	33.48
11/16	2-1/16	3-13/16	COD11S	34.22
11/16	3-7/16	5-3/16	COD11L	35.66
3/4	2-1/4	4	COD12S	36.23
3/4	3-3/4	5-1/2	COD12L	37.25

MADE IN U.S.A.

◆ MINI-BORE

SOLID CARBIDE STEMS — STEEL SHANKS

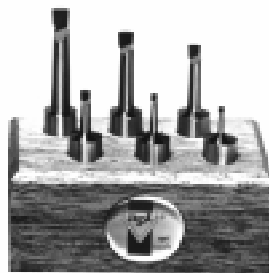

3/8" SHANK SET NO. MA375

6 Piece Set
Includes 1 Piece of Each:
MA1, MA2, MA3, MA4, MA5, MA6
Supplied in Wood Block.
SET PRICE — \$209.00



SINGLE TOOL				
Min. Bore	Bore Depth	Overall Length	Tool No.	Price Each
3/8" SHANK				
1/16	5/16	1-9/16	MA1	26.20
3/32	15/32	1-23/32	MA2	27.05
1/8	5/8	1-7/8	MA3	29.62
5/32	25/32	2-1/32	MA4	36.72
3/16	15/16	2-3/16	MA5	41.65
1/4	1-1/4	2-1/2	MA6	47.91
1/2" SHANK				
1/16	5/16	1-13/16	MB1	28.51
3/32	15/32	1-15/16	MB2	29.47
1/8	5/8	2-1/8	MB3	31.91
5/32	25/32	2-1/4	MB4	39.10
3/16	15/16	2-7/16	MB5	43.96
1/4	1-1/4	2-13/16	MB6	50.23

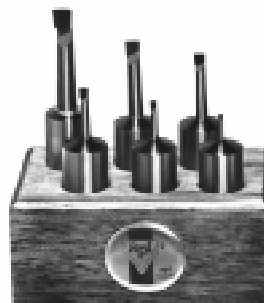

1/2" SHANK SET NO. MB500

6 Piece Set
Includes 1 Piece of Each:
MB1, MB2, MB3, MB4, MB5, MB6
Supplied in Wood Block.
SET PRICE — \$223.00



STUBBY BORING BARS

HIGH SPEED AND CARBIDE TIPPED

- MAXIMUM RIGIDITY
- PRECISION GROUND SHANKS
- SHANKS FEATURE SET SCREW FLATS

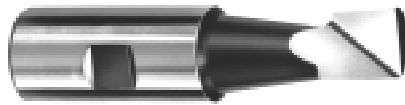

HIGH SPEED STEEL				
Min. Bore	Bore Depth	Overall Length	Tool No.	Price Each
1/2" SHANK				
1/8	1/4	1-21/32	PSBH2	19.50
3/16	5/16	1-13/16	PSBH3	19.50
1/4	7/16	2	PSBH4	19.50
5/16	9/16	2-3/16	PSBH5	19.50
3/8	11/16	2-3/8	PSBH6	20.65
1/2	13/16	2-9/16	PSBH8	21.35
5/8" SHANK				
3/8	11/16	2-5/16	PSCH6	29.50
1/2	15/16	2-9/16	PSCH8	29.50
5/8	1-1/8	2-3/4	PSCH10	29.50
3/4" SHANK				
1/2	1-5/16	2-15/16	PSDH8	49.80
3/4	1-17/32	3-5/32	PSDH12	52.50
1	1-3/4	3-3/8	PSDH16	57.60
1" SHANK				
3/4	1-17/32	3-5/32	PSEH12	54.00
1	1-3/4	3-3/8	PSEH16	57.50
1-1/4	1-31/32	3-19/32	PSEH20	69.75

CARBIDE TIPPED				
Min. Bore	Bore Depth	Overall Length	Tool No.	Price Each
1/2" SHANK				
1/8	1/4	1-21/32	PSBC2	27.50
3/16	5/16	1-13/16	PSBC3	27.50
1/4	7/16	2	PSBC4	27.50
5/16	9/16	2-3/16	PSBC5	27.50
3/8	11/16	2-3/8	PSBC6	27.50
1/2	13/16	2-9/16	PSBC8	27.50
5/8" SHANK				
3/8	11/16	2-15/16	PSCC6	32.72
1/2	15/16	2-9/16	PSCC8	32.72
5/8	1-1/8	2-3/4	PSCC10	32.72
3/4" SHANK				
1/2	1-5/16	2-15/16	PSDC8	32.00
3/4	1-17/32	3-5/32	PSDC12	32.00
1	1-3/4	3-3/8	PSDC16	34.50
1" SHANK				
3/4	1-17/32	3-5/32	PSEC12	34.50
1	1-3/4	3-3/8	PSEC16	34.50
1-1/4	1-31/32	3-19/32	PSEC20	42.50

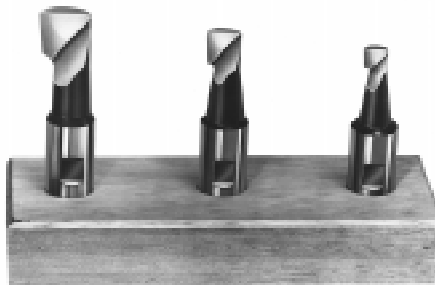

HIGH SPEED STEEL SETS	
1/2" SHANK	5/8" SHANK
<p>SET NO. PSBH500 6 Piece Set Contains 1 piece of each: 1/8, 3/16, 1/4, 5/16, 3/8, 1/2 Supplied in wood block. SET PRICE — \$120.00</p>	<p>SET NO. PSCH625 3 Piece Set Contains 1 piece of each: 3/8, 1/2 and 5/8 Supplied in wood block. SET PRICE — \$88.50</p>
3/4" SHANK	1" SHANK
<p>SET NO. PSDH750 3 Piece Set Contains 1 piece of each: 1/2, 3/4 and 1" Supplied in wood block. SET PRICE — \$159.00</p>	<p>SET NO. PSEH1000 3 Piece Set Contains 1 piece of each: 3/4, 1" and 1-1/4 Supplied in wood block. SET PRICE — \$179.00</p>

CARBIDE TIPPED SETS	
1/2" SHANK	5/8" SHANK
<p>SET NO. PSBC500 6 Piece Set Contains 1 piece of each: 1/8, 3/16, 1/4, 5/16, 3/8, 1/2 Supplied in wood block. SET PRICE — \$159.00</p>	<p>SET NO. PSCC625 3 Piece Set Contains 1 piece of each: 3/8, 1/2 and 5/8 Supplied in wood block. SET PRICE — \$98.00</p>
3/4" SHANK	1" SHANK
<p>SET NO. PSDC750 3 Piece Set Contains 1 piece of each: 1/2, 3/4 and 1" Supplied in wood block. SET PRICE — \$98.00</p>	<p>SET NO. PSEC1000 3 Piece Set Contains 1 piece of each: 3/4, 1" and 1-1/4 Supplied in wood block. SET PRICE — \$110.00</p>



MADE IN U.S.A.

◆ PRECISION BORING HEADS WITH INTEGRATED SHANKS



- Direct reading .001 micrometer dial
- Precision hardened steel
- Boring capacity up to 4"

STRAIGHT SHANKS								
Head Dia.	Shank Dia.	Hole Dia.	Offset Travel	Vert. Hole Spacing	Shank Length	Overall Length	Tool No.	Price Each
2	3/4	3/8	3/4	5/8	2-5/8	5-1/16	BH34A	114.00
2-1/2	3/4	1/2	3/4	3/4	2-5/8	5-13/16	BH34B	137.00
2-1/2	3/4	5/8	3/4	3/4	2-5/8	5-13/16	BH34C	148.00
3	1	3/4	1-1/4	15/16	2-5/8	6-1/8	BH1D	170.00

R-8 SHANKS								
Head Dia.	Shank Dia.	Hole Dia.	Offset Travel	Vert. Hole Spacing	Shank Length	Overall Length	Tool No.	Price Each
2	R-8	3/8	3/4	5/8	4	6-7/16	BHR8A	171.00
2-1/2	R-8	1/2	3/4	3/4	4	7-3/16	BHR8B	183.00
2-1/2	R-8	5/8	3/4	3/4	4	7-3/16	BHR8C	201.00
3	R-8	3/4	1-1/4	15/16	4	7-1/2	BHR8D	228.00

SETS

SET NO. BH34BS

10 Piece Set

Contains 1 Piece of Each:

BH34B 3/4 Shank Boring Head and (1) PB500 1/2" Shank Carbide

Tipped Boring Bar Set. Contains the following sizes in standard, medium, and long lengths: 5/16, 7/16, and 9/16.

Supplied in Special Case.

SET PRICE — \$269.00

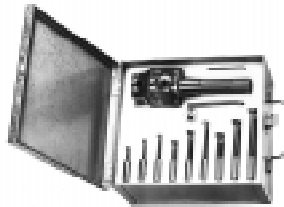

SET NO. BHR8BS

10 Piece Set

Contains 1 Piece of Each:

BHR8B R-8 Shank Boring Head and (1) PB500 1/2" Shank Carbide

Tipped Boring Bar Set. Contains the following sizes in standard, medium, and long lengths: 5/16, 7/16, and 9/16.

Supplied in Special Case.

SET PRICE — \$325.00



◆ BORING HEADS WITH INTERCHANGEABLE SHANKS

BORING HEADS							
Head Dia.	Threaded Back	Hole Dia.	Overall Length	Offset Travel	Vert. Hole Spacing	Tool No.	Price Each
2	7/8 — 20	3/8	2-7/16	3/4	5/8	BHTA	148.00
2-1/2	7/8 — 20	1/2	3-3/16	3/4	3/4	BHTB	160.00
2-1/2	7/8 — 20	5/8	3-3/16	3/4	3/4	BHTC	178.00
3	1-1/2 — 18	3/4	3-1/2	1-1/4	5/16	BHTD	206.00

◆ INTERCHANGEABLE SHANKS FOR BORING HEADS

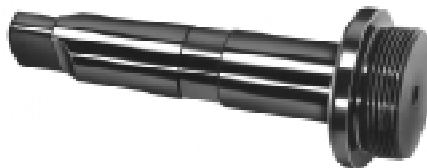

7/8 — 20 THREAD		
Description	Tool No.	Price Each
2 M.T. with Tang	BHQM2	38.60
3 M.T. with Tang	BHQM3	43.20
4 M.T. with Tang	BHQM4	51.00
#30 N.T. with Draw Bar & Drive Flange	BHQS3	89.00
#40 N.T. with Draw Bar & Drive Flange	BHQS4	110.30
1/2" Diameter Straight Shank	BHQ16	22.10
3/4" Diameter Straight Shank	BHQ24	22.10
1" Diameter Straight Shank	BHQ32	22.10
R-8 Shank	BHQR8	47.70

1-1/2 — 18 THREAD		
Description	Tool No.	Price Each
3 M.T. with Tang	BHXM3	54.10
4 M.T. with Tang	BHXM4	61.00
#30 N.T. with Draw Bar & Drive Flange	BHXS3	100.00
#40 N.T. with Draw Bar & Drive Flange	BHXS4	130.90
1" Diameter Straight Shank	BHX32	31.60
1-1/4" Diameter Straight Shank	BHX40	44.80
1-1/2" Diameter Straight Shank	BHX48	44.80
R-8 Shank	BHXR8	55.30



◆ MICRO-RANGE™ ADJUSTABLE BORING BAR

- For use on CNC and conventional mills and lathes
- Can be precision adjusted while tool is in machine
- .002 graduation adjustment
- C5/C6 carbide insert and torx® wrench included with each tool

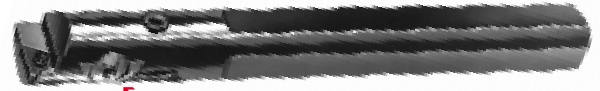

↖ Micrometer adjustment screw

		TPGH TRIANGLE — POSITIVE RAKE GROUND ALL OVER WITH CHIP GROOVE ON ONE SIDE				
CARBIDE INSERTS						
Insert Number	Radius	I.C.	Thickness	Price Each		
				C-2	C-5 & C-6	TiN* Coated
TPGH-21.50	0	1/4	3/32	4.75	5.23	6.11
TPGH-21.51	1/64	1/4	3/32	4.75	5.23	6.11
TPGH-21.52	1/32	1/4	3/32	4.75	5.23	6.11
TPGH-321	1/64	3/8	1/8	5.13	5.70	6.95
TPGH-322	1/32	3/8	1/8	5.13	5.70	6.95

*C-5 & C-6 Grade TiN Coated

REPLACEMENT PARTS		
Part No.	Description	Price Each
TF832-285	Torx® drive flat head screw for 3/8" I.C.	1.75
TF440-195	Torx® drive flat head screw for 1/4" I.C.	1.25
CTW-10	Torx® wrench for 3/8" I.C.	2.45
CTW-6	Torx® wrench for 1/4" I.C.	1.95

HOLDERS							
Min.* Bore	Max.* Bore	Shank Dia. or Style	Overall Length	Max. Depth of Cut	Insert Size I.C.	Tool No.	Price Each
3/4	15/16	5/8	5-1/4	3-1/8	1/4	TLA625S	187.75
3/4	15/16	R-8	7-3/8	3-1/8	1/4	TLA625R8	222.75
15/16	1-3/16	3/4	6-5/16	4-1/8	3/8	TLA750S	214.75
15/16	1-3/16	R-8	8-3/8	4-1/8	3/8	TLA750R8	256.75
1-3/16	1-5/8	1"	8-1/4	5-1/8	3/8	TLA1000S	245.75
1-3/16	1-5/8	R-8	9-3/8	5-1/8	3/8	TLA1000R8	297.75
1-7/16	2-3/8	1-1/4	10-5/16	6-1/4	3/8	TLA1250S	282.75
1-7/16	2-3/8	R-8	10-1/2	6-1/4	3/8	TLA1250R8	335.75

*NOTE: Bore diameter produced when using insert TPGH-21.51 (radius 1/64).

REPLACEMENT PARTS		
Part No.	Description	Price Each
MSTLA625	Micro-range screw for use with 5/8 dia. holder	8.50
MSTLA750	Micro-range screw for use with 3/4 dia. holder	9.00
MSTLA1000	Micro-range screw for use with 1" dia. holder	10.00
MSTLA1250	Micro-range screw for use with 1-1/4" dia. holder	10.50

MADE IN U.S.A. — EXCLUSIVELY BY A.P.T.

◆ CARBIDE INDEXABLE SOCKET HEAD CAP SCREW COUNTERBORES

- Significant increase in cutting speeds over high speed steel
- No regrinding
- One carbide insert fits all size holders
- Outlasts high speed on abrasive materials
- No clamps to impede chip flow
- C5/C6 carbide insert and torx® wrench included with each tool.



		TPGH TRIANGLE — POSITIVE RAKE GROUND ALL OVER WITH CHIP GROOVE ON ONE SIDE				
CARBIDE INSERTS						
Insert Number	Radius	I.C.	Thickness	Price Each		
				C-2	C-5 & C-6	TiN* Coated
TPGH-21.50	0	1/4	3/32	4.75	5.23	6.11
TPGH-21.51	1/64	1/4	3/32	4.75	5.23	6.11
TPGH-21.52	1/32	1/4	3/32	4.75	5.23	6.11

*C-5 & C-6 Grade TiN Coated

REPLACEMENT PARTS		
Part No.	Description	Price Each
TF440-195	Torx® drive flat head screw for insert	1.25
CTW-6	Torx® wrench	1.95

HOLDERS							
Cap Screw Size	Pilot Dia.	Outer Dia.	Shank Dia.	Overall Length	No. of Flutes	Tool No.	Price Each
3/8	13/32	19/32	1/2	4-3/8	1	CB375	59.35
7/16	15/32	11/16	1/2	4-7/16	1	CB437	62.30
1/2	17/32	25/32	5/8	4-1/2	1	CB500	69.65
5/8	21/32	31/32	5/8	4-5/8	2	CB625	94.75
3/4	13/16	1-3/16	3/4	4-3/4	3	CB750	117.25
7/8	15/16	1-3/8	3/4	4-7/8	3	CB875	144.75
1	1-1/16	1-9/16	3/4	5	3	CB1000	157.35

SETS

SET NO. CBS2

3 Piece Set
Contains 1 Piece of Each:
3/4, 7/8, and 1"
Torx® wrench
Supplied in wood block.
SET PRICE — \$399.00



SET NO. CBS1

4 Piece Set
Contains 1 Piece of Each:
3/8, 7/16, 1/2, and 5/8
Torx® wrench
Supplied in wood block.
SET PRICE — \$259.00



MADE IN U.S.A.— EXCLUSIVELY BY A.P.T.

◆ TRI-LEAD INDEXABLE BORING BARS

- Inserts can be indexed and replaced without loss of hole size or depth
- Made of tempered alloy steel for rigidity
- Cartridges are hardened and ground to precision accuracy

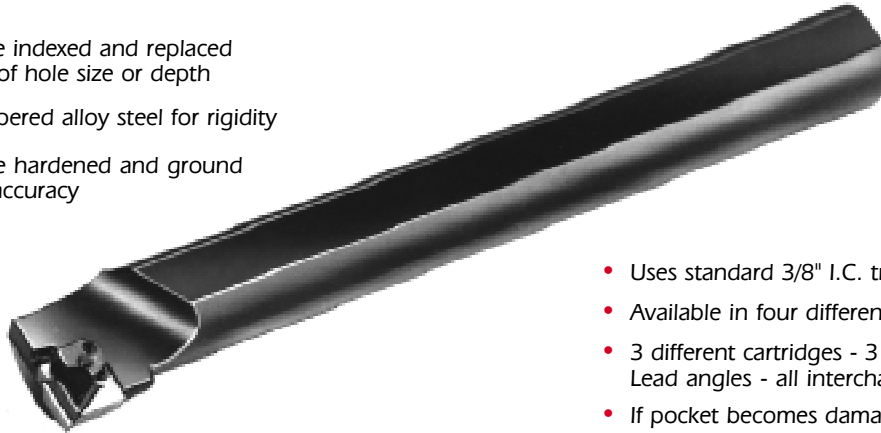

- Uses standard 3/8" I.C. triangle inserts
- Available in four different shank sizes
- 3 different cartridges - 3 different Lead angles - all interchangeable
- If pocket becomes damaged during use simply replace the cartridge

HOLDERS					
Minimum Bore	Distance Across Flats	Center to Sharp Point	Overall Length	Tool No.	Price Each
3/4" SHANK					
1-1/16	11/16	11/16	4	TL344	72.60
1-1/16	11/16	11/16	5-1/2	TL345	80.00
1-1/16	11/16	11/16	7	TL346	87.00
1-1/16	11/16	11/16	10	TL347	101.50
1" SHANK					
1-1/4	7/8	3/4	4	TL105	91.90
1-1/4	7/8	3/4	7	TL106	99.00
1-1/4	7/8	3/4	9	TL107	106.50
1-1/4	7/8	3/4	12	TL108	122.65
1-1/4" SHANK					
1-1/2	1-1/8	13/16	6-1/2	TL125	110.85
1-1/2	1-1/8	13/16	9	TL126	123.00
1-1/2	1-1/8	13/16	11-1/2	TL127	135.15
1-1/2	1-1/8	13/16	15	TL128	154.60
1-1/2" SHANK					
1-3/4	1-1/4	1	15	TL138	194.35

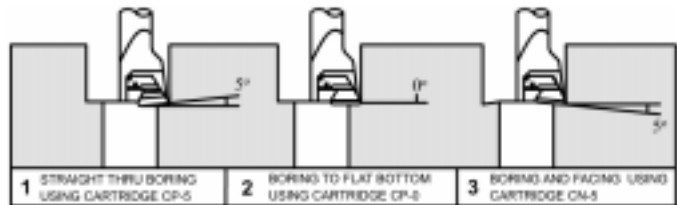

All bars complete with CPO Cartridge (0° no lead) and TPG321 C5/C6 insert.

INTERCHANGEABLE CARTRIDGES
CP5 +5° Positive Lead Cartridge **8.70**
CN5 -5° Negative Lead Cartridge **8.70**

CARTRIDGE AND INSERT PACKAGE:

- 10 TPG321 C5/C6 Carbide Inserts
- 1 CP5 Cartridge (+5° Positive lead)
- 1 CN5 Cartridge (-5° Negative lead)

Part No. TLPK – \$59.00

Each tool is supplied with (1) TPG-321 C5/C6 insert.



TPG TRIANGLE — Positive rake — Ground all over

CARBIDE INSERTS

Insert Number	Radius	I.C.	Thickness	Price Each		
				C-2	C-5 & C-6	TiN Coated*
TPG-320	0	3/8	1/8	4.89	5.18	6.21
TPG-321	1/64	3/8	1/8	4.89	5.18	6.21
TPG-322	1/32	3/8	1/8	4.89	5.18	6.21
TPG-323	3/64	3/8	1/8	4.89	5.18	6.21
TPG-324	1/16	3/8	1/8	4.89	5.18	6.21

*C-5 & C-6 Grade TiN Coated

REPLACEMENT PARTS LIST

Part No.	Description	Price Each
CTL	Hold Down Clamp	5.55
CBT-12	3/8" I.C. Chipbreaker	3.19
SHIM41	3/8" I.C. Shim	3.75
CP0	0° Lead Cartridge	8.70
CP5	+5° Positive Lead Cartridge	8.70
CN5	-5° Negative Lead Cartridge	8.70
CRP-1	Roll Pin	.35
CF440-14	Shim Screw	.35
CS540-38	Cartridge Screw (2 Required)	.35
CS832-58	Clamp Screw for 3/4" Shanks	.35
CS832-34	Clamp Screw for 1", 1-1/4" and 1-1/2" Shanks	.35

SETS

3/4" SHANK	1" SHANK	1-1/4" SHANK	3/4", 1" and 1-1/4" SHANK
SET NO. TL348 Contains 1 piece of Each: TL344, TL345, TL346 3 Piece Set SET PRICE— \$235.00	SET NO. TL109 Contains 1 piece of Each: TL105, TL106, TL107 3 Piece Set SET PRICE— \$295.00	SET NO. TL129 Contains 1 piece of Each: TL125, TL126, TL127 3 Piece Set SET PRICE - \$365.00	SET NO. TL130 Contains 1 piece of Each: TL345, TL106, TL126 3 Piece Set SET PRICE— \$299.00

◆ SUPER-LOK BORING BARS

PATENT NO. 4334-446



REGULAR LENGTH AND LONG LENGTH

- No special components
- The only replacement part is a cap screw
- Insert is held rigidly by a unique clamping design
- Uses standard 1/4" and 3/8" I.C. triangle inserts
- Chose from a wide variety of shank sizes and lengths

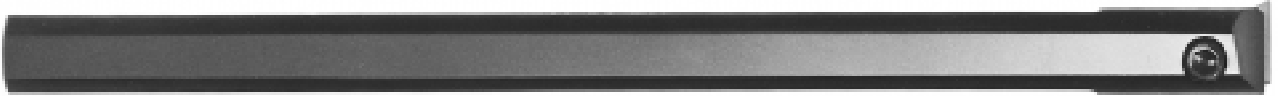
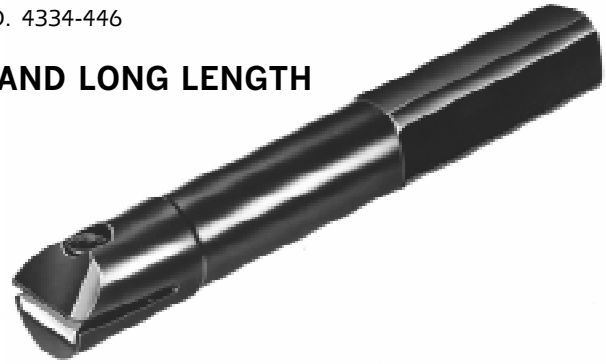

Each tool is supplied with (1) TPG C-6 insert.

SETS	
1/2" SHANK	
SET NO. LB500	
Includes all 6 Pieces, regular length shown C-6 Carbide inserts included Supplied in wood block SET PRICE – \$265.00	
5/8" SHANK	
SET NO. LC625	
Includes all 6 Pieces, regular length shown C-6 Carbide inserts included Supplied in wood block SET PRICE – \$306.00	
3/4" SHANK	
SET NO. LD750	
Includes all 8 Pieces, regular length shown C-6 Carbide inserts included Supplied in wood block SET PRICE – \$464.00	
1" SHANK	
SET NO. LE1000	
Includes all 9 Pieces shown C-6 Carbide inserts included Supplied in wood block SET PRICE – \$692.00	

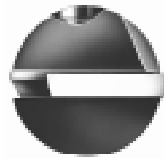

END VIEW



HOLDERS						
Minimum Bore	Bore Depth	Distance Across Flats	Overall Length	Inserts Size I.C.	Tool No.	Price Each
1/2" SHANK						
1/2	1-1/2	7/16	3	1/4	LB8S	41.40
1/2	2-1/4	7/16	3-3/4	1/4	LB8M	42.60
9/16	1-3/4	7/16	3-1/4	1/4	LB9S	41.40
9/16	2-5/8	7/16	4-1/8	1/4	LB9M	44.70
9/16**	–	7/16	8	1/4	LB9L	52.00
5/8	2	7/16	3-1/2	1/4	LB10S	42.60
5/8	3	7/16	4-1/2	1/4	LB10M	44.70
5/8" SHANK						
1/2	1-1/2	9/16	3-1/4	1/4	LC8S	47.20
1/2	2-1/4	9/16	4	1/4	LC8M	48.90
5/8	2	9/16	3-3/4	1/4	LC10S	47.20
5/8	3	9/16	4-3/4	1/4	LC10M	50.30
11/16**	–	9/16	9	3/8	LC11L	62.80
3/4	2-3/4	9/16	4-1/2	3/8	LC12S	50.30
3/4	3-3/4	9/16	5-1/2	3/8	LC12M	53.80
3/4" SHANK						
1/2	1-1/2	5/8	3-1/2	1/4	LD8S	53.80
1/2	2-1/4	5/8	4-1/4	1/4	LD8M	53.80
5/8	2	5/8	4	1/4	LD10S	53.80
5/8	3	5/8	5	1/4	LD10M	57.30
3/4	2-3/4	5/8	4-3/4	3/8	LD12S	57.30
3/4	3-3/4	5/8	5-3/4	3/8	LD12M	59.10
13/16	3	5/8	5	3/8	LD13S	59.10
13/16	4-1/2	5/8	6-1/2	3/8	LD13M	61.60
13/16**	–	5/8	10	3/8	LD13L	71.60
1" SHANK						
3/4	3	7/8	5-1/4	3/8	LE12S	65.80
3/4	4	7/8	6-1/4	3/8	LE12M	72.40
13/16	3-1/4	7/8	5-1/2	3/8	LE13S	69.00
13/16	4-1/2	7/8	6-3/4	3/8	LE13M	76.00
15/16	3-1/2	7/8	5-3/4	3/8	LE15S	72.50
15/16	4-3/4	7/8	7	3/8	LE15M	79.80
1-1/16	4	7/8	6-1/4	3/8	LE17S	76.20
1-1/16	5-1/4	7/8	7-1/2	3/8	LE17M	83.70
1-1/16**	–	7/8	12	3/8	LE17L	88.60
1-1/4" SHANK						
1-5/16**	–	1-1/8	15	3/8	LF21L	111.70
1-1/2" SHANK						
1-9/16**	–	1-1/4	15	3/8	LG25L	140.40

	TPG	TRIANGLE — POSITIVE RAKE GROUND ALL OVER				
CARBIDE INSERTS						
Insert Number	Radius	I.C.	Thickness	Price Each		
				C-2	C-5 & C-6	TiN Coated*
TPG-221	1/64	1/4	1/8	4.14	4.37	5.30
TPG-321	1/64	3/8	1/8	4.89	5.18	6.21

*C-5 & C-6 Grade TiN Coated

REPLACEMENT PARTS LIST		
Part No.	Description	Price Each
CS632-38	Screw for 1/4" I.C. Holders	.40
CS1032-12	Screw for 3/8" I.C. Holders	.50
CS1032-38	Screw for LC11L Only	.50
CS1032-58	Screw for LE15S, LE15M	.50
CS1420-58	Screw for LE17L Only	.40
CS1420-34	Screw for LF21L, LG25L	.40

** Indicates Long Length



MADE IN U.S.A. — EXCLUSIVELY BY A.P.T.

◆ EASY-BORE BORING BARS

- Precision broached holes accept standard tool bits
- Use in any typical boring operation
- Made of stress resistant steel to minimize or eliminate vibration
- Easily reworked to accept adjustable boring tips for high precision boring

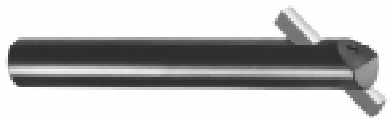

SINGLE END - 45° STYLE				
Dia. of Bar	Overall Length	Tool Bit Diameter	Tool Number	Price Each
1/4	2-1/2	5/32 round	BA1	7.60
5/16	2-1/2	3/16 round	BA2	8.65
3/8	3	3/16 round	BA3	9.30
1/2	3	3/16 square	BA4	12.35
9/16	4-1/2	3/16 square	BA5	14.00
5/8	5	1/4 square	BA6	14.50
3/4	6	1/4 square	BA7	16.70
1	6	5/16 square	BA9	21.00
1	6	3/8 square	BA9X	21.00
1-1/4	8	1/2 square	BA11	34.20
1-1/2	9	1/2 square	BA15	45.60

Prices do not include tool bits. Replacement screws available. Please inquire.

DOUBLE END - 45° AND 90° STYLES				
Dia. of Bar	Overall Length	Tool Bit Diameter	Tool Number	Price Each
1/4	5	5/32 round	BD1	12.65
5/16	5	3/16 round	BD2	14.40
3/8	6	3/16 round	BD3	15.60
1/2	6	3/16 square	BD4	20.40
9/16	9	3/16 square	BD5	23.00
5/8	10	1/4 square	BD6	24.00
3/4	12	1/4 square	BD7	27.60
1	12	5/16 square	BD9	34.40
1	12	3/8 square	BD9X	34.40
1-1/4	16	1/2 square	BD11	57.00
1-1/2	18	1/2 square	BD15	75.90

Prices do not include tool bits. Replacement screws available. Please inquire.



SINGLE END - 90° STYLE				
Dia. of Bar	Overall Length	Tool Bit Diameter	Tool Number	Price Each
1/4	2-1/2	5/32 round	BS1	7.60
5/16	2-1/2	3/16 round	BS2	8.65
3/8	3	3/16 round	BS3	9.30
1/2	3	3/16 square	BS4	12.35
9/16	4-1/2	3/16 square	BS5	14.00
5/8	5	1/4 square	BS6	14.50
3/4	6	1/4 square	BS7	16.70
1	6	5/16 square	BS9	21.00
1	6	3/8 square	BS9X	21.00
1-1/4	8	1/2 square	BS11	34.20
1-1/2	9	1/2 square	BS15	45.60

Prices do not include tool bits. Replacement screws available. Please inquire.

◆ BORING TOOL HOLDERS



TOOL HOLDERS				
Boring Bar Diameter	Tool Bit Size	Size of Holder	Tool No.	Price Each
9/16	3/16	3/8 x 7/8 x 5-3/8	THB2	68.00
3/4	1/4	1/2 x 1-1/8 x 6-1/8	THB3	79.00

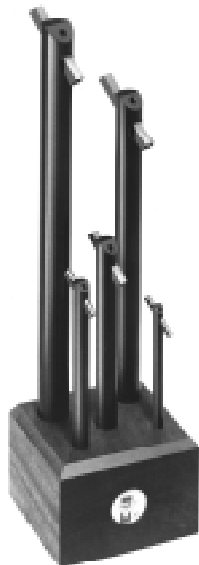

HIGH SPEED TOOL BITS		
Size	Overall Length	Price Each
● LIST NO. 704 — ROUND		
5/32	3-1/8	3.24
3/16	3-1/2	5.00
● LIST NO. 700 — SQUARE		
3/16	2-1/2	3.13
1/4	2-1/2	3.24
1/4	4	4.99
5/16	2-1/2	3.71
5/16	4	6.34
1/2	4	10.40
1/2	6	15.15

SET
DOUBLE END
SET NO. BD459
5 Piece Set
Contains 1 Piece of Each:
BD1, BD3, BD4, BD6, BD7
Supplied in Wood Block
SET PRICE — \$100.00

Set does not include tool bits.

COBALT TOOL BITS		
Size	Overall Length	Price Each
● LIST NO. 700C — 5% COBALT—SQUARE		
3/16	2-1/2	4.25
1/4	2-1/2	4.80
1/4	4	7.55
5/16	2-1/2	5.60
5/16	4	9.62
1/2	4	16.90
1/2	6	23.07
● LIST NO. 700SC — 8% SUPER COBALT—SQUARE		
3/16	2-1/2	5.60
1/4	2-1/2	6.90
5/16	2-1/2	8.80
1/2	4	20.80

LATHE TOOLING

MORSE TAPER LATHE CENTERS

DEAD CENTERS

Hardened and Ground — 60° Included point Angle

- ◆ LIST NO. LA100 — CARBON STEEL
- ◆ LIST NO. LA200 — HIGH SPEED STEEL
- ◆ LIST NO. LA300 — CARBIDE TIPPED



Morse Taper	Overall Length	Price Each		
		Carbon List No. LA100	H.S. Steel List No. LA200	Carb. Tipped List No. LA300
		1	3-3/16	2.45
2	3-15/16	2.95	6.50	9.50
3	4-15/16	4.75	8.75	15.70
4	6-5/16	6.75	13.80	22.85
5	7-7/8	13.50	29.00	38.00
6	11	31.95	54.00	69.50

HEAVY DUTY LIVE CENTERS

Hardened and Ground

PRECISION HIGH QUALITY BEARINGS

- ◆ LIST NO. LA400 — PRECISION GRADE
- ◆ LIST NO. LA500 — SUPERIOR PRECISION GRADE

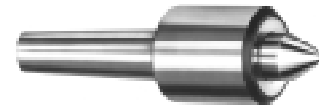

Morse Taper	Max. Lbs. of Work Piece	Tolerance	Price Each		
			List No. LA400	List No. LA500	
			1	220	.0003
2	460	.0003	39.50	.0001	59.00
3	925	.0003	52.50	.0001	69.00
4	1850	.0003	69.50	.0001	95.00
5	4400	.0004	99.00	.0002	127.00
6	7700	.0004	185.00	.0002	310.00

◆ LATHE MANDRELS

Hardened and Ground Throughout

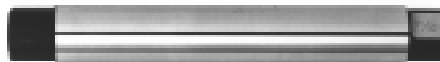

These mandrels are made of hardened steel and are accurately ground to size. Designed for setting up accurately bored or reamed blanks and castings for pulleys, handwheels or hubs, on centers, so that the outside diameter can be turned concentrically with the axis of the hole in which the mandrel is fixed.

Size	Overall Length	Tool No.	Price Each
1/8	2-1/2	LM4	5.45
5/32	3	LM5	5.95
3/16	3	LM6	5.95
7/32	3-3/4	LM7	6.50
1/4	3-3/4	LM8	6.50
9/32	4	LM9	6.75
5/16	4	LM10	6.75
11/32	4-1/4	LM11	6.95
3/8	4-1/4	LM12	6.95
13/32	4-1/2	LM13	7.50
7/16	4-1/2	LM14	7.50
15/32	5	LM15	8.50
1/2	5	LM16	8.50
17/32	5-1/4	LM17	9.60
9/16	5-1/4	LM18	9.60
19/32	5-1/2	LM19	9.60
5/8	5-1/2	LM20	9.60
21/32	5-3/4	LM21	9.95

Size	Overall Length	Tool No.	Price Each
11/16	5-3/4	LM22	9.95
23/32	6	LM23	9.95
3/4	6	LM24	9.95
25/32	6-1/4	LM25	12.50
13/16	6-1/4	LM26	12.50
27/32	6-1/2	LM27	12.50
7/8	6-1/2	LM28	12.50
29/32	6-3/4	LM29	13.75
15/16	6-3/4	LM30	13.75
31/32	7	LM31	13.75
1	7	LM32	13.75
1-1/16	7-1/4	LM34	17.25
1-1/8	7-1/2	LM36	17.25
1-3/16	7-3/4	LM38	19.95
1-1/4	8	LM40	19.95
1-5/16	8-1/4	LM42	24.50
1-3/8	8-1/2	LM44	24.50
1-7/16	8-3/4	LM46	28.50

Size	Overall Length	Tool No.	Price Each
1-1/2	9	LM48	28.50
1-9/16	9-1/4	LM50	32.25
1-5/8	9-1/2	LM52	32.25
1-11/16	9-3/4	LM54	36.50
1-3/4	10	LM56	36.50
1-13/16	10-1/4	LM58	41.75
1-7/8	10-1/2	LM60	41.75
1-15/16	10-3/4	LM62	45.50
2	11	LM64	45.50
2-1/8	11-1/2	LM68	49.75
2-1/4	12	LM72	55.75
2-3/8	12	LM76	59.75
2-1/2	12-1/2	LM82	67.00
2-5/8	12-1/2	LM84	78.00
2-3/4	13	LM88	85.00
2-7/8	13	LM92	89.00
3	13	LM96	99.00

◆ EXPANDING MANDRELS

Hardened and Precision Ground



Center holes are ground and lapped. Automatic expansion feature can be utilized on any bore within the range of the mandrel. Sizes up to 1" furnished with one sleeve, over 1" two sleeves.

Size Range	Length of Arbor	Length of Sleeve	Tool No.	Price Each	Size Range	Length of Arbor	Length of Sleeve	Tool No.	Price Each
1/2 - 9/16	5	2-1/2	LME1	55.00	7/8 - 1	7	3-1/4	LME5	89.50
9/16 - 21/32	6	2-3/4	LME2	69.00	1 - 1-1/4	9	4	LME6	159.00
21/32 - 3/4	7	2-3/4	LME3	72.00	1-1/4 - 1-1/2	9	4	LME7	169.50
3/4 - 7/8	7	3-1/4	LME4	84.00	1-1/2 - 2	11-1/2	5	LME8	185.00

SET

SET NO. LME100
5 Piece Mandrel Set
1/2 to 1"
SET PRICE — \$359.00



MADE IN U.S.A.— EXCLUSIVELY BY A.P.T.

◆ TRI-DEX INDEXABLE END MILLS REGULAR LENGTH

TRIANGLE INSERTED — POSITIVE RAKE — 90° CUT



- Low cost
- Finest quality and workmanship
- A large range of standard diameters available
- A wide variety of shanks to choose from
- All sizes use standard 3/8" I.C. triangle inserts
- One clamp fits all tool sizes
- Used effectively on low horsepower milling machines
- Simple, rugged clamp design
- Versatile - can be used for many different types of cuts
- Can be used with inserts with wiping flats for improved finish

 TPG TRIANGLE — Positive rake — Ground all over						
CARBIDE INSERTS						
Insert Number	Radius	I.C.	Thickness	Price Each		
				C-2	C-5 & C-6	TiN Coated*
TPG-321	1/64	3/8	1/8	4.89	5.18	6.21
TPG-322	1/32	3/8	1/8	4.89	5.18	6.21
TPG-323	3/64	3/8	1/8	4.89	5.18	6.21
TPG-324	1/16	3/8	1/8	4.89	5.18	6.21

*C-5 & C-6 Grade TiN Coated

 TPC TRIANGLE — Positive rake — Ground all over with wiping flats on three corners.						
CARBIDE INSERTS WITH WIPING FLATS						
Insert Number	Radius	I.C.	Thickness	Price Each		
				C-2	C-5 & C-6	TiN Coated*
TPC-32ZR	-	3/8	1/8	4.80	4.98	5.85

*C-5 & C-6 Grade TiN Coated

REPLACEMENT PARTS LIST		
Part No.	Description	Price Each
CTD-2	Hold Down Clamp	5.55
CS832-12	Clamp Screw	.50
CSW	9/64 Allen Wrench for 8-32 Screw	.50

END MILLS				
Cutting Diameter	Shank Dia. or Style	No. of Inserts	Tool Number	Price Each
3/4	1/2	1	EM075-50	55.00
3/4	3/4	1	EM075-34	55.00
3/4	R-8	1	EM075-R8	74.00
7/8	3/4	1	EM087-34	62.00
1	1	1	EM100-1	70.00
1	3/4	1	EM100-34	68.00
1	R-8	1	EM100-R8	74.00
1-1/4	1	2	EM125-1	77.00
1-1/4	3/4	2	EM125-34	79.00
1-1/4	R-8	2	EM125-R8	86.00
1-1/4	40V-Flange	2	EM125-V40	185.44
1-3/8	1	2	EM137-1	91.43
1-3/8	3/4	2	EM137-34	94.00
1-3/8	R-8	2	EM137-R8	98.00
1-1/2	1	3	EM150-1	103.00
1-1/2	3/4	3	EM150-34	106.00
1-1/2	R-8	3	EM150-R8	114.00
1-1/2	40V-Flange	3	EM150-V40	213.00
1-5/8	3/4	3	EM162-34	108.00
1-5/8	1	3	EM162-1	108.00
1-5/8	R-8	3	EM162-R8	122.00
1-3/4	1	3	EM175-1	124.00
1-3/4	3/4	3	EM175-34	126.00
1-3/4	R-8	3	EM175-R8	143.00
2	1	3	EM20-1	141.00
2	3/4	3	EM20-34	144.00
2	R-8	3	EM20-R8	156.00
2	30 NST	3	EM20-S30	182.00
2	40 NST	3	EM20-S40	207.00
2	40V-Flange	3	EM20-V40	247.00
2-1/4	R-8	4	EM225-R8	207.00
2-1/2	1-1/4	5	EM250-125	227.00
2-1/2	R-8	5	EM250-R8	241.00
2-3/4	R-8	5	EM275-R8	246.00
3	1-1/4	5	EM300-125	250.00
3	R-8	5	EM300-R8	271.00
3	40 NST	5	EM300-S40	271.00
3	40V-Flange	5	EM300-V40	310.00
3-1/2	R-8	5	EM350-R8	296.00
4	R-8	6	EM400-R8	341.00

Inserts sold separately. Cutter body length 1-5/8".



◆ TRI-DEX INDEXABLE END MILL SETS REGULAR LENGTH

TRIANGLE INSERTED — POSITIVE RAKE — 90° CUT

Sets supplied in wood block.

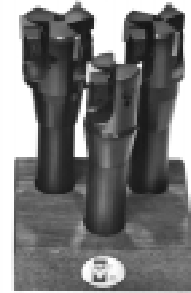

TRI-DEX SETS			
Shank Styles	Cutting Diameter	Set No.	Price Each
3/4	3/4, 7/8, 1	EM34	187.00
3/4	1-1/4, 1-1/2, 2"	EM750	328.00
1	1-1/4, 1-1/2, 2"	EM1000	321.00
R-8	1", 1-1/4, 1-1/2	EM8R1	274.00
R-8	2", 2-1/2, 3"	EM8R2	668.00
R-8	2", 2-1/4, 2-1/2	EM8R3	602.00
R-8	2-3/4, 3", 3-1/2	EM8R4	811.00
V-Flange	1-1/4, 1-1/2, 2"	EMV1000	645.44

Inserts sold separately.

◆ TRI-DEX INDEXABLE END MILLS WITH COOLANT FEED

TRIANGLE INSERTED — POSITIVE RAKE — 90° CUT

Sets supplied in wood block.

- Tool life is greatly improved when coolant is fed to each cutting edge of the tool
- Allows increased cutting speeds and feeds



- Greatly improves surface finishes
- Extends insert life
- Uses standard 3/8" I.C. triangle inserts
- One clamp fits all tools

TPG TRIANGLE — Positive rake ground all over						
CARBIDE INSERTS						
Insert Number	Radius	I.C.	Thickness	Price Each		
				C-2	C-5 & C-6	TiN Coated*
TPG-321	1/64	3/8	1/8	4.89	5.18	6.21
TPG-322	1/32	3/8	1/8	4.89	5.18	6.21
TPG-323	3/64	3/8	1/8	4.89	5.18	6.21
TPG-324	1/16	3/8	1/8	4.89	5.18	6.21

*C-5 & C-6 Grade TiN Coated

TPC TRIANGLE — Positive rake ground all over with wiping flats on three corners.						
CARBIDE INSERTS WITH WIPING FLATS						
Insert Number	Radius	I.C.	Thickness	Price Each		
				C-2	C-5 & C-6	TiN Coated*
TPC-32ZR	—	3/8	1/8	4.80	4.98	5.85

*C-5 & C-6 Grade TiN Coated

END MILLS				
Cutting Diameter	Shank Dia. or Style	No. of Inserts	Tool Number	Price Each
3/4	3/4	1	EMC075-34	71.76
1	3/4	1	EMC100-34	89.59
1	1	1	EMC100-1	89.59
1-1/4	3/4	2	EMC125-34	100.00
1-1/4	1	2	EMC125-1	100.00
1-1/2	1	3	EMC150-1	131.96
1-3/4	1	3	EMC175-1	159.39
2	1	3	EMC20-1	175.15
3	1-1/4	5	EMC300-125	302.34

Inserts sold separately. Cutter body length 1-5/8".

SETS			
Shank Styles	Cutting Diameter	Set Number	Price Each
3/4	3/4, 1", 1-1/4	EMC34	259.00
1	1-1/2, 1-3/4, 2"	EMC1000	466.50

Inserts sold separately.

REPLACEMENT PARTS LIST		
Part No.	Description	Price Each
CTD-2	Hold Down Clamp	5.55
CS832-12	Clamp Screw	.50
CSW	9/64 Allen Wrench for 8-32 Screw	.50



MADE IN U.S.A. — EXCLUSIVELY BY A.P.T.

◆ TRI-DEX INDEXABLE END MILLS MINIATURE SERIES

TRIANGLE INSERTED — POSITIVE RAKE — 90° CUT

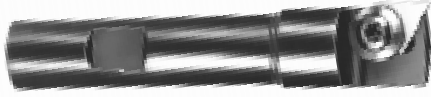

- One clamp fits all sizes
- Uses standard 1/4" I.C. triangle inserts
- Fine surface finishes

END MILLS						
Cutting Diameter	Shank Diameter	Body Length	Overall Length	Tool Number	Price Each	
STANDARD						
1/2	1/2	1	3	EMM500-5	49.00	
9/16	1/2	1	3	EMM562-5	49.00	
5/8	1/2	1	3	EMM625-5	49.00	
METRIC						
12mm	1/2	1	3	EMM12M-5	49.00	
15mm	1/2	1	3	EMM15M-5	49.00	
18mm	1/2	1	3	EMM18M-5	49.00	

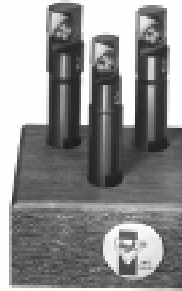

SETS	
STANDARD	
Contains 1 piece of each: 1/2, 9/16, 5/8	
SET NO. EMM500	
PRICE*— \$144.00	
METRIC	
Contains 1 piece of each: 12mm, 15mm, 18mm	
SET NO. EMM500A	
PRICE*— \$144.00	

*Torx® wrench included. Set supplied in wood block. Inserts sold separately.



TPG TRIANGLE — Positive rake ground all over

CARBIDE INSERTS

Insert Number	Radius	I.C.	Thickness	Price Each		
				C-2	C-5 & C-6	TiN Coated*
TPG-221	1/64	1/4	1/8	4.14	4.37	5.30
TPG-222	1/32	1/4	1/8	4.14	4.37	5.30
TPG-223	3/64	1/4	1/8	4.14	4.37	5.30

*C-5 & C-6 Grade TiN Coated

REPLACEMENT PARTS LIST

Part No.	Description	Price Each
CTM	Hold Down Clamp	1.85
CB632-38	Torx® Clamp Screw	1.50
CTW-10	T-10 Torx® Wrench for 6-32 Screw	2.45

◆ TRI-DEX INDEXABLE END MILLS EXTRA LONG LENGTH

TRIANGLE INSERTED — POSITIVE RAKE — 90° CUT

CUTTER BODY LENGTH 4"



- Used where extra long reach is required
- Available in a wide range of diameters
- A large variety of shank styles
- Uses standard 3/8" I.C. triangle inserts
- One clamp fits all size

END MILLS					
Cutting Diameter	Shank Dia. or Style	Overall Length	No. of Inserts	Tool Number	Price Each
3/4	3/4	6-1/4	1	EML075-34	78.00
1	3/4	6-1/4	1	EML100-34	95.00
1-1/4	1	6-1/4	2	EML125-1	109.00
1-1/4	R-8	8-1/4	2	EML125-R8	122.00
1-1/2	1	6-1/4	3	EML150-1	144.00
1-1/2	R-8	8-1/4	3	EML150-R8	161.00
2	1	6-1/4	3	EML20-1	194.00
2	1-1/4	6-1/4	3	EML20-125	184.00
2	R-8	8-1/4	3	EML20-R8	216.00
2-1/2	1-1/4	6-1/4	5	EML250-125	298.00
2-1/2	R-8	8-1/4	5	EML250-R8	316.00
3	1-1/4	6-1/4	5	EML300-125	321.00
3	R-8	8-1/4	5	EML300-R8	356.00

Inserts sold separately.

SETS

R-8 SHANK Contains 1 piece of each: 2, 2-1/2, 3 Supplied in wood block. SET NO. EML8R2 PRICE*— \$884.00	1-1/4" SHANK Contains 1 piece of each: 2, 2-1/2, 3 Supplied in wood block. SET NO. EML12500 PRICE*— \$799.00
--	---

*Inserts sold separately.



TPG TRIANGLE — Positive rake ground all over

CARBIDE INSERTS

Insert Number	Radius	I.C.	Thickness	Price Each		
				C-2	C-5 & C-6	TiN Coated*
TPG-321	1/64	3/8	1/8	4.89	5.18	6.21
TPG-322	1/32	3/8	1/8	4.89	5.18	6.21
TPG-323	3/64	3/8	1/8	4.89	5.18	6.21
TPG-324	1/16	3/8	1/8	4.89	5.18	6.21

*C-5 & C-6 Grade TiN Coated



TPC TRIANGLE — Positive rake ground all over with wiping flats on three corners.

CARBIDE INSERTS WITH WIPING FLATS

Insert Number	Radius	I.C.	Thickness	Price Each		
				C-2	C-5 & C-6	TiN Coated*
TPC-32ZR	—	3/8	1/8	4.80	4.98	5.85

*C-5 & C-6 Grade TiN Coated

REPLACEMENT PARTS LIST

Part No.	Description	Price Each
CTD-2	Hold Down Clamp	5.55
CS832-12	Clamp Screw	.50
CSW	9/64 Allen Wrench for 8-32 Screw	.50



◆ ROUND INDEXABLE END MILLS REGULAR LENGTH

ROUND INSERTED — POSITIVE RAKE

BODY CUTTER LENGTH 1-5/8"

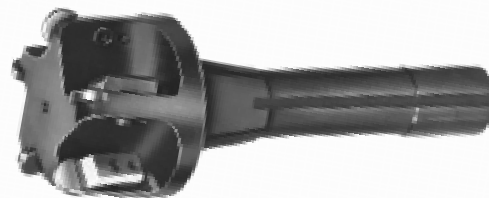

- Use as a roughing cutter for higher stock removal
- Use in applications where a radius corner is desired
- Adjust speeds and feeds for good surface finishes
- Use effectively on low horsepower milling machines
- Achieve better finishes
- More cutting edges
- Use standard 1/2" round inserts

END MILLS					
Cutting Diameter	Shank Dia. or Style	No. of Inserts	Tool Number	Price Each	
3/4	3/4	1	EMR075-34	61.00	
7/8	3/4	1	EMR087-34	68.00	
1	3/4	1	EMR100-34	75.00	
1	R-8	1	EMR100-R8	79.00	
1-1/4	1	2	EMR125-1	84.50	
1-1/4	3/4	2	EMR125-34	87.00	
1-1/4	R-8	2	EMR125-R8	94.00	
1-1/2	1	3	EMR150-1	112.00	
1-1/2	3/4	3	EMR150-34	114.00	
1-1/2	R-8	3	EMR150-R8	126.00	
1-3/4	3/4	3	EMR175-34	137.00	
1-3/4	R-8	3	EMR175-R8	156.00	
2	1	3	EMR20-1	156.00	
2	3/4	3	EMR20-34	159.00	
2	R-8	3	EMR20-R8	165.00	
2-1/2	1-1/4	5	EMR250-125	252.00	
2-1/2	R-8	5	EMR250-R8	263.00	
3	1-1/4	5	EMR300-125	270.00	
3	R-8	5	EMR300-R8	286.00	

Inserts sold separately.

SETS				TOOL ROOM SET		
Shank Styles	Cutting Diameter	Tool Number	Price Each	SET NO. EM3000		
3/4	3/4, 7/8, 1	EMR34	203.00	3 Piece Set		
3/4	1-1/4, 1-1/2, 2	EMR750	360.00	Contains 1 Piece of Ea. 1" Diameter		
1	1-1/4, 1-1/2, 2	EMR1000	351.00	Triangle Inserted-EM100-34		
R-8	1, 1-1/4, 1-1/2	EMR8R1	299.00	Square Inserted-QMD100-34		
R-8	2, 2-1/2, 3	EMR8R2	712.00	Round Inserted-EMR100-34		
				SET PRICE - \$221.00		

Inserts sold separately.

RPG		ROUND — Positive rake ground all over				
CARBIDE INSERTS						
Insert Number	Radius	I.C.	Thickness	Price Each		
				C-2	C-5 & C-6	TiN Coated*
RPG-42	1/4	1/2	1/8	4.40	4.95	5.90

*C-5 & C-6 Grade TiN Coated

REPLACEMENT PARTS LIST		
Part No.	Description	Price Each
CTD-2	Hold Down Clamp	5.55
CS832-12	Clamp Screw	.50
CSW	9/64 Allen Wrench for 8-32 Screw	.50

◆ ROUND INDEXABLE END MILLS EXTRA LONG LENGTH

ROUND INSERTED — POSITIVE RAKE

BODY CUTTER LENGTH 4"



- Use when extra long reach is required
- Higher metal removal rates
- Achieve better finishes
- More cutting edges
- Use standard 1/2" round inserts

END MILLS					
Cutting Diameter	Shank Dia. or Style	Overall Length	No. of Inserts	Tool Number	Price Each
3/4	3/4	6-1/4	1	EMLR075-34	84.00
1-1/4	R-8	8-1/4	2	EMLR125-R8	133.00
1-1/2	1	6-1/4	3	EMLR150-1	157.00
1-1/2	R-8	8-1/4	3	EMLR150-R8	178.00
2	1	6-1/4	3	EMLR20-1	206.00
2	1-1/4	6-1/4	3	EMLR20-125	206.00
2	R-8	8-1/4	3	EMLR20-R8	236.00
2-1/2	1-1/4	6-1/4	5	EMLR250-125	327.00
2-1/2	R-8	8-1/4	5	EMLR250-R8	344.00
3	1-1/4	6-1/4	5	EMLR300-125	351.00
3	R-8	8-1/4	5	EMLR300-R8	385.00

Inserts sold separately.

RPG		ROUND — Positive rake — Ground all over				
CARBIDE INSERTS						
Insert Number	Radius	I.C.	Thickness	Price Each		
				C-2	C-5 & C-6	TiN Coated*
RPG-42	1/4	1/2	1/8	4.40	4.95	5.90

*C-5 & C-6 Grade TiN Coated

REPLACEMENT PARTS LIST		
Part No.	Description	Price Each
CTD-2	Hold Down Clamp	5.55
CS832-12	Clamp Screw	.50
CSW	9/64 Allen Wrench for 8-32 Screw	.50



MADE IN U.S.A. — EXCLUSIVELY BY A.P.T.

◆ QUAD-MILL INDEXABLE END MILLS

SQUARE INSERTED — POSITIVE RAKE — 15° AND 45° LEADS

- Finest quality and workmanship
- Uses standard 1/2" I.C. square inserts
- One clamp fits all tools
- Easy stock removal on low horsepower equipment
- Higher metal removal rates
- Fine surface finishes



END MILLS				
Cutting Diameter	Shank Dia. or Style	No. of Inserts	Tool Number	Price Each
15° LEAD**				
1	3/4	1	QM100-34	76.00
1	R-8	1	QM100-R8	95.00
2	1	3	QM20-100	149.00
2	R-8	3	QM20-R8	167.00
2	1-1/4	3	QM20-125	149.00
2-1/2	R-8	5	QM250-R8	259.00
2-1/2	1-1/4	5	QM250-125	241.00
3	R-8	5	QM30-R8	287.00
3	1-1/4	5	QM30-125	263.00
45° LEAD				
3/4	3/4	1	QMD075-34	68.00
1	3/4	1	QMD100-34	76.00
1	R-8	1	QMD100-R8	95.00
1-1/4	3/4	1	QMD125-34	89.00
1-1/4	R-8	1	QMD125-R8	118.00
1-1/2	3/4	1	QMD150-34	111.00
1-1/2	R-8	1	QMD150-R8	134.00
2	3/4	3	QMD20-34	149.00
2	R-8	3	QMD20-R8	166.00
2	1-1/4	3	QMD20-125	149.00
2-1/2	R-8	4	QMD250-R8	259.00
3	R-8	5	QMD30-R8	287.00
3	1-1/4	5	QMD30-125	263.00

Inserts sold separately.

** Note: Do Not Use SPG-424 — 1/16 Radius on 15° Lead End Mills

SPG SQUARE
Positive rake — Ground all over

SPU SQUARE
Positive rake — Ground top and bottom

CARBIDE INSERTS						
Insert Number	Radius	I.C.	Thickness	Price Each		
				C-2	C-5 & C-6	TiN Coated*
SPG-422	1/32	1/2	1/8	4.75	5.12	5.80
SPG-423	3/64	1/2	1/8	4.75	5.12	5.80
**SPG-424	1/16	1/2	1/8	4.75	5.12	5.80
SPU-422	1/32	1/2	1/8	4.10	4.46	5.13
SPU-423	3/64	1/2	1/8	4.10	4.46	5.13

*C-5 & C-6 Grade TiN Coated

** Note: Do Not Use SPG-424 — 1/16 Radius on 15° Lead End Mills

REPLACEMENT PARTS LIST		
Part No.	Description	Price Each
CTD-2	Hold Down Clamp	5.55
CS832-12	Clamp Screw	.50
CSW	9/64 Allen Wrench for 8-32 Screw	.50

SPC SQUARE — Positive rake — Ground all over with wiping flats on four corners

CARBIDE INSERTS WITH WIPING FLATS

Insert Number	Radius	I.C.	Thickness	Price Each		
				C-2	C-5 & C-6	TiN Coated*
SPC-42ZR	—	1/2	1/8	4.95	5.30	6.35

*C-5 & C-6 Grade TiN Coated



QUAD-MILL SETS			
Shank Dia. or Style	Cutting Diameter	Set Number	Price Each
15° LEAD			
R-8	2, 2-1/2, 3	QMS15-R82	707.00
1-1/4	2, 2-1/2, 3	QMS15-125	650.00
45° LEAD			
R-8	1, 1-1/4, 1-1/2	QMS45-R81	344.00
R-8	2, 2-1/2, 3	QMS45-R82	707.00
3/4	1, 1-1/4, 1-1/2	QMS45-34	276.00

Inserts sold separately.





◆ DYNA-MILL INDEXABLE END MILLS HEAVY DUTY

TRIANGLE INSERTED — NEGATIVE RAKE — 90° CUT



- For use in heavy duty milling application
- Higher metal removal rates
- Both styles use standard 1/2" I.C. inserts
- Unique clamping mechanism, one clamp fits all sizes



END MILLS					
Cutting Diameter	Length of Cut	Shank Diameter	No. of Inserts	Tool Number	Price Each
1-1/4	2-1/8	1-1/4	2	DM19	102.00
1-1/2	2-1/8	1-1/4	2	DM20	122.00
1-3/4	2-1/8	1-1/4	3	DM21	148.00
2	2-1/8	1-1/4	3	DM22	161.00
2-1/2	2-1/8	1-1/4	3	DM22.5	229.00
3	2-1/8	1-1/4	5	DM23	267.00

FACE MILLS					
Cutting Diameter	Length of Cut	Hole Size	No. of Inserts	Tool Number	Price Each
4	2-3/4	1-1/4	6	DM24	356.00
5	2-3/4	1-1/2	7	DM25	424.00
6	2-3/4	2	8	DM26	536.00
8	2-3/4	2-1/2	10	DM28	736.00

Inserts sold separately.

Inserts sold separately.

Insert Number	Radius	I.C.	Thickness	Price Each		
				C-2	C-5 & C-6	TIN Coated*
TNMG-431	1/64	1/2	3/16	3.94	4.46	5.20
TNMG-432	1/32	1/2	3/16	3.94	4.46	5.20
TNMG-433	3/64	1/2	3/16	3.94	4.46	5.20
TNMG-434	1/16	1/2	3/16	3.94	4.46	5.20
TNMG-438	1/8	1/2	3/16	3.94	4.46	5.20

*C-5 & C-6 Grade TiN Coated

REPLACEMENT PARTS LIST		
Part No.	Description	Price Each
CDM	Hold Down Clamp	7.60
CB1032-12	Clamp Screw for DM19 only	.50
CS1032-58	Clamp Screw	.50
AS5818-2	Arbor Screw for DM24 only	2.00

◆ TRI-DEX INDEXABLE FACE MILLS

TRIANGLE INSERTED — POSITIVE RAKE — 90° CUT

- Achieve face milling cuts at higher R.P.M.'s
- Use in low horse power milling machines
- Results in finer finishes

- One clamp fits all sizes
- Uses standard 3/8" I.C. triangle inserts
- Use with standard shell end mill adapters



Insert Number	Radius	I.C.	Thickness	Price Each		
				C-2	C-5 & C-6	TIN Coated*
TPG-320	0	3/8	1/8	4.89	5.18	6.21
TPG-321	1/64	3/8	1/8	4.89	5.18	6.21
TPG-322	1/32	3/8	1/8	4.89	5.18	6.21
TPG-323	3/64	3/8	1/8	4.89	5.18	6.21
TPG-324	1/16	3/8	1/8	4.89	5.18	6.21

*C-5 & C-6 Grade TiN Coated

FACE MILLS					
Cutting Diameter	Length of Cut	Hole Size	No. of Inserts	Tool Number	Price Each
2	1-3/4	3/4	3	EMS200	148.00
2-1/2	2	3/4	5	EMS250	213.00
3	2	1	5	EMS300	229.00

Inserts sold separately.

REPLACEMENT PARTS LIST		
Part No.	Description	Price Each
CTD-2	Hold Down Clamp	5.55
CSW	9/64 Allen Wrench for 8-32 Screw	.50
CS832-12	Clamp Screw	.50
AS3824-114	Shell Mill Arbor Screw EMS200	1.25
AS3824-112	Shell Mill Arbor Screw EMS250	1.50
AS1220-112	Shell Mill Arbor Screw EMS300	1.75



MADE IN U.S.A. — EXCLUSIVELY BY A.P.T.

SLOT MASTER® ADJUSTABLE WIDTH INDEXABLE MILLING CUTTER

87° PARALLELOGRAMS — POSITIVE RAKE

RUGGED, SIMPLE DESIGN

•
FINEST QUALITY

•
LOWEST PRICE

•
EASY WIDTH ADJUSTMENT
FOR EXACT SLOT SIZE



1) SLOTTING OR STAGGERED CUTTER

With the ring setting gauge for the shank type, inserts may be quickly indexed and precision adjusted to produce any cutting width within the range of the cutter.

2) HALF SIDE MILLING CUTTER

Half side milling may be accomplished by positioning the inserts in a left or right hand orientation.

SHANK LENGTH = 3" OAL MINUS CUTTING BODY WIDTH

SHANK TYPE									
Cutter dia.	Cutting Width Range	Cutting Body Width	Shank Dia.	Number of Inserts	Use Wedge No.	Use Insert No.	Right or Left Hand	Tool Number	Price Each
2	.375-.530	.330	3/4	4	W2	CTA-2	Right	SM2475R-2	215.00
2	.485-.765	.450	3/4	4	W4	CTA-4	Right	SM2475R-4	229.00
2	.375-.530	.330	1"	4	W2	CTA-2	Right	SM2410R-2	215.00
2	.485-.765	.450	1"	4	W4	CTA-4	Right	SM2410R-4	229.00
2	.375-.530	.330	3/4	4	W2	CTA-2	Left	SM2475L-2	237.00
2	.485-.765	.450	3/4	4	W4	CTA-4	Left	SM2475L-4	251.00
2	.375-.530	.330	1"	4	W2	CTA-2	Left	SM2410L-2	237.00
2	.485-.765	.450	1"	4	W4	CTA-4	Left	SM2410L-4	251.00
3	.375-.530	.330	1"	6	W2	CTA-2	Right	SM3610R-2	286.00
3	.485-.765	.450	1"	6	W4	CTA-4	Right	SM3610R-4	313.00
3	.720-1.025	.690	1"	4	W6	CTA-6	Right	SM3410R-6	274.00
3	.982-1.265	.950	1"	4	W8	CTA-8	Right	SM3410R-8	299.00
3	.375-.530	.330	1"	6	W2	CTA-2	Left	SM3610L-2	315.00
3	.485-.765	.450	1"	6	W4	CTA-4	Left	SM3610L-4	344.00
3	.720-1.025	.690	1"	4	W6	CTA-6	Left	SM3410L-6	314.00
3	.982-1.265	.950	1"	4	W8	CTA-8	Left	SM3410L-8	330.00

Inserts sold separately.

RING SETTING GAUGE

With the Slot Master® Ring Setting Gauge, cutter widths can be precision set for infinitely variable slot widths.

Tool No.	Shank Diameter	Price Each
SMG 750	3/4	52.90
SMG1000	1"	56.93

CTA 87° Parallelograms all surfaces ground — Positive rake													
CARBIDE INSERTS													
Insert Number	Please Specify Radii								I.C.	Thickness	Price Each		
	0	1/64	1/32	1/16	3/32	1/8	—	C-2			C-5	TiN* Coated	
CTA-2**	0	1/64	1/32	1/16	3/32	1/8	—	.355	5/32	5.63	5.97	6.78	
CTA-4	0	1/64	1/32	1/16	3/32	1/8	—	.460	3/16	6.92	7.15	8.13	
CTA-6	—	—	1/32	1/16	3/32	1/8	—	.685	3/16	9.85	10.45	13.81	
CTA-8	—	—	1/32	1/16	3/32	1/8	1/4	.750	3/16	11.28	12.43	14.47	

*C-5 & C-6 Grade TiN Coated

**88° Parallelogram

REPLACEMENT PARTS

Part No.	Description	Price Each
W2	Wedge	6.33
W4	Wedge	6.33
W6	Wedge	6.33
W8	Wedge	6.33
SMC1	Screw for W2 & W4 Wedges	2.00
SMC2	Screw for W6 & W8 Wedges	2.00
SS1420-38	Screw for Ring Setting Gauges	.50



♦ SLOT MASTER[®] ADJUSTABLE WIDTH INDEXABLE MILLING CUTTER

87° PARALLELOGRAMS — POSITIVE RAKE

- RUGGED, SIMPLE DESIGN
- FINEST QUALITY • LOWEST PRICE
- EASY WIDTH ADJUSTMENT FOR EXACT SLOT SIZE

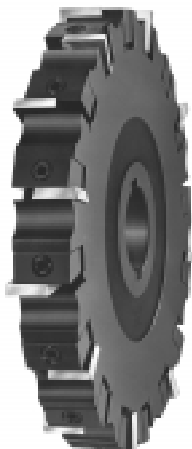

4 CUTTERS IN 1 TOOL

1) SLOTTING OR STAGGERED CUTTER

With the magnetic micrometer gauge for the arbor type, inserts may be quickly indexed and precision adjusted to produce any cutting width within the range of the cutter.

2) SLAB MILLING CUTTER

Cutter bodies may be interlocked in pairs to accommodate indexable staggered tooth orientation.

3) STRADDLE MILLING CUTTER

Cutters are double key-wayed to allow multiple cutter set-up of an arbor for straddle milling.

4) HALF SIDE MILLING CUTTER

Half side milling may be accomplished by positioning the inserts in a left or right hand orientation.

ARBOR TYPE

Cutter Dia.	Cutting Width Range	Cutter Body Width	Arbor Dia.	Number of Inserts	Use Insert No.	Use Wedge No.	Tool Number	Price Each
4	.375-.530	.330	1-1/4	8	CTA-2	W2	SM48122	366.00
4	.485-.765	.450	1-1/4	8	CTA-4	W4	SM48124	366.00
6	.375-.530	.330	1-1/4	12	CTA-2	W2	SM612122	451.00
6	.485-.765	.450	1-1/4	12	CTA-4	W4	SM612124	451.00
6	.720-1.025	.690	1-1/4	12	CTA-6	W6	SM612126	467.00
6	.982-1.265	.950	1-1/4	12	CTA-8	W8	SM612128	480.00
6	.375-.530	.330	1-1/2	12	CTA-2	W2	SM612152	450.00
6	.485-.765	.450	1-1/2	12	CTA-4	W4	SM612154	450.00
6	.720-1.025	.690	1-1/2	12	CTA-6	W6	SM612156	467.00
6	.982-1.265	.950	1-1/4	12	CTA-8	W8	SM612158	480.00
8	.375-.530	.330	1-1/4	16	CTA-2	W2	SM816122	560.00
8	.485-.765	.450	1-1/4	16	CTA-4	W4	SM816124	560.00
8	.720-1.025	.690	1-1/4	16	CTA-6	W6	SM816126	574.00
8	.982-1.265	.950	1-1/4	16	CTA-8	W8	SM816128	595.00
8	.375-.530	.330	1-1/2	16	CTA-2	W2	SM816152	560.00
8	.485-.765	.450	1-1/2	16	CTA-4	W4	SM816154	560.00
8	.720-1.025	.690	1-1/2	16	CTA-6	W6	SM816156	573.00
8	.982-1.265	.950	1-1/2	16	CTA-8	W8	SM816158	595.00
10	.375-.530	.330	2	20	CTA-2	W2	SM102022	698.00
10	.485-.765	.450	2	20	CTA-4	W4	SM102024	698.00
10	.720-1.025	.690	2	20	CTA-6	W6	SM102026	725.00
10	.982-1.265	.950	2	20	CTA-8	W8	SM102028	750.00
12	.485-.765	.450	2	24	CTA-4	W4	SM122424	835.00
12	.720-1.025	.690	2	24	CTA-6	W6	SM122426	881.00
12	.982-1.265	.950	2	24	CTA-8	W8	SM122428	913.00

Inserts sold separately

REPLACEMENT PARTS LIST

Part No.	Description	Price Each
W2	Wedge	6.33
W4	Wedge	6.33
W6	Wedge	6.33
W8	Wedge	6.33
SMC1	Wedge Screw for W2 and W4 Wedges	2.00
SMC2	Wedge Screw for W6 and W8 Wedges	2.00

CTA

87° Parallelograms all surfaces ground — Positive rake



CARBIDE INSERTS

Insert Number	Please Specify Radii							I.C.	Thickness	Price Each		
	0	1/64	1/32	1/16	3/32	1/8	—			C-2	C-5	TiN* Coated
CTA-2**	0	1/64	1/32	1/16	3/32	1/8	—	.355	5/32	5.63	5.97	6.78
CTA-4	0	1/64	1/32	1/16	3.32	1/8	—	.460	3/16	6.92	7.15	8.13
CTA-6	—	—	1/32	1/16	3/32	1/8	—	.685	3/16	9.85	10.45	13.81
CTA-8	—	—	1/32	1/16	3/32	1/8	1/4	.750	3/16	11.28	12.43	14.47

* C-5 & C-6 Grade TiN Coated

** 88° Parallelogram

MAGNETIC MICROMETER SETTING GAUGE

With the Slot Master[®] Setting Gauge, cutter widths can be precision set for infinitely variable slot widths and inserts can be indexed while the cutter remains on the arbor.

TOOL NO. SMC2000 PRICE EACH — \$333.00





MADE IN U.S.A. — EXCLUSIVELY BY A.P.T.

◆ ADJUSTABLE CLAMP/CHIPBREAKER INDEXABLE TURNING TOOL HOLDERS

SMALL SHANK SERIES

- Adjustable Combination Clamp/Chipbreaker
- No tool like it on the Market!
- Each tool has precision Hardened and ground pockets
- Uses inexpensive 1/4" I.C. triangle inserts
- Replaces old style brazed tip tool bits

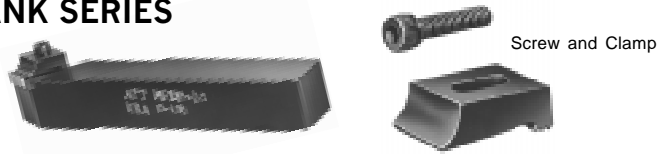

POSITIVE RAKE							
Shank Height and Width	Overall Length	"A" Series 0° Lead	"B" Series 15° Lead	"D" Series 30° Lead	"F" Series Facing Tool	"G" Series 0° Lead Offset	Price Each
RIGHT HAND							
3/8	2-1/2	MPAR-6	MPBR-6	MPDR-6	MPFR-6	MPGR-6	24.75
1/2	3-1/2	MPAR-8	MPBR-8	MPDR-8	MPFR-8	MPGR-8	26.85
5/8	4	MPAR-10	MPBR-10	MPDR-10	MPFR-10	MPGR-10	29.75
LEFT HAND							
3/8	2-1/2	MPAL-6	MPBL-6	MPDL-6	MPFL-6	MPGL-6	24.75
1/2	3-1/2	MPAL-8	MPBL-8	MPDL-8	MPFL-8	MPGL-8	26.85
5/8	4	MPAL-10	MPBL-10	MPDL-10	MPFL-10	MPGL-10	29.75

Inserts sold separately.

NEGATIVE RAKE							
Shank Height and Width	Overall Length	"A" Series 0° Lead	"B" Series 15° Lead	"D" Series 30° Lead	"F" Series Facing Tool	"G" Series 0° Lead Offset	Price Each
RIGHT HAND							
3/8	2-1/2	MNAR-6	MNBR-6	MNDR-6	MNFR-6	MNGR-6	24.75
1/2	3-1/2	MNAR-8	MNBR-8	MNDR-8	MNFR-8	MNGR-8	26.85
5/8	4	MNAR-10	MNBR-10	MNDR-10	MNFR-10	MNGR-10	29.75
LEFT HAND							
3/8	2-1/2	MNAL-6	MNBL-6	MNDL-6	MNFL-6	MNGL-6	24.75
1/2	3-1/2	MNAL-8	MNBL-8	MNDL-8	MNFL-8	MNGL-8	26.85
5/8	4	MNAL-10	MNBL-10	MNDL-10	MNFL-10	MNGL-10	29.75

Inserts sold separately.

TPG		TNG				
CARBIDE INSERTS						
Insert Number	Radius	I.C.	Thickness	Price Each		
				C-2	C-5 & C6	TiN Coated*
POSITIVE						
TPG-221	1/64	1/4	1/8	4.14	4.37	5.30
TPG-222	1/32	1/4	1/8	4.14	4.37	5.30
TPG-223	3/64	1/4	1/8	4.14	4.37	5.30
NEGATIVE						
TNG-221	1/64	1/4	1/8	2.62	2.81	4.04
TNG-222	1/32	1/4	1/8	2.62	2.81	4.04

*C-5 & C-6 Grade TiN Coated

SETS – 3/8" SHANK	
POSITIVE RAKE SET NO. MP38S Includes 1 Piece of Each: MPBR-6, MPDR-6 MPFR-6, MPGR-6 SET PRICE – \$99.00	NEGATIVE RAKE SET NO. MN38S Includes 1 Piece of Each: MNBR-6, MNDR-6 MNFR-6, MNGR-6 SET PRICE – \$99.00

SETS – 1/2" SHANK	
POSITIVE RAKE SET NO. MP12S Includes 1 Piece of Each: MPBR-8, MPDR-8 MPFR-8, MPGR-8 SET PRICE – \$107.00	NEGATIVE RAKE SET NO. MN12S Includes 1 Piece of Each: MNBR-8, MNDR-8 MNFR-8, MNGR-8 SET PRICE – \$107.00

REPLACEMENT PARTS LIST		
Part Number	Description	Price Each
CMD	Combination Clamp and Chipbreaker	6.21
CS540-12	Clamp Screw	.35

◆ INDEXABLE PROFILE/TRACING TOOL HOLDERS

–5° LEAD ANGLE — NEGATIVE RAKE

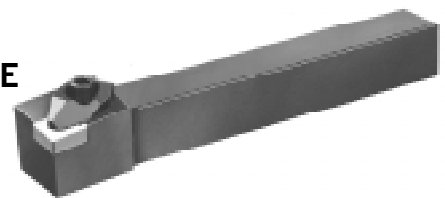

NEGATIVE RAKE						
Shank Height	Shank Width	Overall Length	Insert I.C.	Tool Number		Price Each
				Left Hand	Right Hand	
3/4	3/4	6	1/2	TR80L-12	TR80R-12	33.00
1	1	6	1/2	TR80L-16	TR80R-16	37.50
1	1	6	3/4	TR80L-16A	TR80R-16A	39.50
1-1/4	1-1/4	7	3/4	TR80L-20	TR80R-20	42.00
1-1/4	1	6	1/2	TR80L-85	TR80R-85	42.00
1-1/4	1	6	3/4	TR80L-85A	TR80R-85A	42.00
1-1/2	1	7	3/4	TR80L-86	TR80R-86	44.00

Inserts sold separately.

CNMP		CNMG			
CARBIDE INSERTS					
Insert Number	Radius	I.C.	Thickness	Price Each	
				C-5 & C6	TiN Coated*
CNMG-431	1/64	1/2	3/16	3.81	4.35
CNMP-431	1/64	1/2	3/16	4.70	5.40
CNMG-432	1/32	1/2	3/16	3.81	4.35
CNMP-432	1/32	1/2	3/16	4.70	5.40
CNMP-642	1/32	3/4	1/4	10.45	12.02
CNMG-643	3/64	3/4	1/4	8.24	10.83
CNMP-643	3/64	3/4	1/4	10.45	12.02
CNMG-644	1/16	3/4	1/4	8.24	10.83

*C-5 & C-6 Grade TiN Coated

REPLACEMENT PARTS LIST		
Part Number	Description	Price Each
TRC-1	1/2 I.C. Hold Down Clamp	7.18
CS1032-58	Screw for TRC-1 Clamp	.50
TRC-2	3/4 I.C. Hold Down Clamp	10.06
CS1428-78	Screw for TRC-2 Clamp	.35



ADJUSTABLE CLAMP/CHIPBREAKER INDEXABLE TURNING TOOL HOLDERS

LARGE SHANK SERIES

- Adjustable chipbreaker eliminates stocking various sizes
- Precision hardened and ground pockets
- Regrind inserts at substantial savings
- Tools are easily repaired by simply replacing the cartridge
- Uses standard 3/8" and 1/2" I.C. Triangle inserts

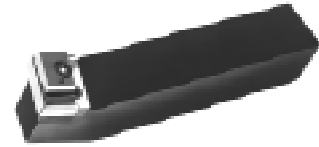

A Overall Length	B Shank Width	C Shank Height	Insert I.C.	POSITIVE RAKE		NEGATIVE RAKE		Price Each	
				"A" Series 0° Lead Angle		"A" Series 0° Lead Angle			
				Right	Left	Right	Left		
4-1/2	3/4	3/4	3/8	PTAR-12	PTAL-12	NTAR-12	NTAL-12	38.50	<p>"A" Series 0° Lead Angle</p>
6	1	1	3/8	PTAR-16	PTAL-16	NTAR-16	NTAL-16	45.00	
6	1	1	1/2	PTAR-16A	PTAL-16A	NTAR-16A	NTAL-16A	45.00	
6	1-1/4	1-1/4	1/2	PTAR-20	PTAL-20	NTAR-20	NTAL-20	49.00	
6	1	1-1/4	3/8	PTAR-85	PTAL-85	NTAR-85	NTAL-85	49.00	
6	1	1-1/4	1/2	PTAR-85A	PTAL-85A	NTAR-85A	NTAL-85A	49.00	
6	1	1-1/2	1/2	-	PTAL-86	NTAR-86	NTAL-86	52.50	
A Overall Length	B Shank Width	C Shank Height	Insert I.C.	"B" Series 15° Lead Angle		"B" Series 15° Lead Angle		Price Each	
Right		Left		Right		Left			
4-1/2	3/4	3/4	3/8	PTBR-12	PTBL-12	-	NTBL-12	38.50	<p>"B" Series 15° Lead Angle</p>
6	1	1	3/8	PTBR-16	PTBL-16	NTBR-16	NTBL-16	45.00	
6	1	1	1/2	PTBR-16A	-	NTBR-16A	NTBL-16A	45.00	
6	1-1/4	1-1/4	1/2	PTBR-20	PTBL-20	NTBR-20	NTBL-20	49.00	
6	1	1-1/4	3/8	PTBR-85	PTBL-85	NTBR-85	NTBL-85	49.00	
6	1	1-1/4	1/2	PTBR-85A	PTBL-85A	NTBR-85A	NTBL-85A	49.00	
6	1	1-1/2	1/2	PTBR-86	PTBL-86	NTBR-86	NTBL-86	52.50	
A Overall Length	B Shank Width	C Shank Height	Insert I.C.	"D" Series 30° Lead Angle		"D" Series 30° Lead Angle		Price Each	
Right		Left		Right		Left			
4-1/2	3/4	3/4	3/8	PTDR-12	PTDL-12	NTDR-12	NTDL-12	38.50	<p>"D" Series 30° Lead Angle</p>
6	1	1	3/8	PTDR-16	PTDL-16	NTDR-16	NTDL-16	45.00	
6	1	1	1/2	PTDR-16A	PTDL-16A	NTDR-16A	NTDL-16A	45.00	
6	1-1/4	1-1/4	1/2	PTDR-20	PTDL-20	NTDR-20	NTDL-20	49.00	
6	1	1-1/4	3/8	PTDR-85	PTDL-85	NTDR-85	NTDL-85	49.00	
6	1	1-1/4	1/2	PTDR-85A	-	NTDR-85A	NTDL-85A	49.00	
6	1	1-1/2	1/2	PTDR-86	-	NTDR-86	NTDL-86	52.50	
A Overall Length	B Shank Width	C Shank Height	Insert I.C.	"F" Series Facing Tool		"F" Series Facing Tool		Price Each	
Right		Left		Right		Left			
4-1/2	3/4	3/4	3/8	PTFR-12	PTFL-12	NTFR-12	NTFL-12	38.50	<p>"F" Series Facing Tool</p>
6	1	1	3/8	PTFR-16	PTFL-16	NTFR-16	NTFL-16	45.00	
6	1	1	1/2	PTFR-16A	PTFL-16A	NTFR-16A	NTFL-16A	45.00	
6	1-1/4	1-1/4	1/2	PTFR-20	PTFL-20	NTFR-20	NTFL-20	49.00	
6	1	1-1/4	3/8	PTFR-85	PTFL-85	NTFR-85	NTFL-85	49.00	
6	1	1-1/4	1/2	PTFR-85A	PTFL-85A	NTFR-85A	NTFL-85A	49.00	
6	1	1-1/2	1/2	PTFR-86	PTFL-86	NTFR-86	NTFL-86	52.50	
A Overall Length	B Shank Width	C Shank Height	Insert I.C.	"G" Series 0° Lead Offset		"G" Series 0° Lead Offset		Price Each	
Right		Left		Right		Left			
4-1/2	3/4	3/4	3/8	PTGR-12	PTGL-12	NTGR-12	NTGL-12	38.50	<p>"G" Series 0° Lead Offset</p>
6	1	1	3/8	PTGR-16	PTGL-16	NTGR-16	NTGL-16	45.00	
6	1	1	1/2	PTGR-16A	PTGL-16A	NTGR-16A	NTGL-16A	45.00	
6	1-1/4	1-1/4	1/2	PTGR-20	PTGL-20	NTGR-20	NTGL-20	49.00	
6	1	1-1/4	3/8	PTGR-85	PTGL-85	NTGR-85	NTGL-85	49.00	
6	1	1-1/4	1/2	PTGR-85A	PTGL-85A	NTGR-85A	NTGL-85A	49.00	
6	1	1-1/2	1/2	PTGR-86	PTGL-86	NTGR-86	NTGL-86	52.50	

Inserts sold separately.

REPLACEMENT PARTS LIST

For 3/8" I.C. Right Hand Holders			For 3/8" I.C. Left Hand Holders			For 1/2" I.C. Right Hand Holders			For 1/2" I.C. Left Hand Holders		
Part No.	Description	Price Each	Part No.	Description	Price Each	Part No.	Description	Price Each	Part No.	Description	Price Each
CP3R	Cartridge-Positive	13.23	CP3L	Cartridge-Positive	13.23	CP4R	Cartridge-Positive	15.24	CP4L	Cartridge-Positive	15.24
CN3R	Cartridge-Negative	13.23	CN3L	Cartridge-Negative	13.23	CN4R	Cartridge-Negative	15.24	CN4L	Cartridge-Negative	15.24
CS540-38	Cartridge Screw	.35	CS540-38	Cartridge Screw	.35	CS1032-12	Cartridge Screw	.50	CS1032-12	Cartridge Screw	.50
SHIM41	Positive Shim	3.75	SHIM41	Positive Shim	3.75	SHIM37	Positive Shim	4.59	SHIM37	Positive Shim	4.59
SHIM48	Negative Shim	3.99	SHIM48	Negative Shim	3.99	SHIM26	Negative Shim	4.31	SHIM26	Negative Shim	4.31
CF440-14	Shim Screw	.35	CF440-14	Shim Screw	.35	CF832-38	Shim Screw	.35	CF832-38	Shim Screw	.35
CB-3	Chipbreaker	2.99	CB-3	Chipbreaker	2.99	CB-4	Chipbreaker	4.89	CB-4	Chipbreaker	4.89
CRP-1	Roll Pin	.35	CRP-1	Roll Pin	.35	CRP-2	Roll Pin	.35	CRP-2	Roll Pin	.35
CR-3	Clamp	6.73	CL-3	Clamp	6.73	CR-4	Clamp	7.48	CL-4	Clamp	7.48
CS1032-34	Clamp Screw	.35	CS1032-34	Clamp Screw	.35	CS1420-1	Clamp Screw	.35	CS1420-1	Clamp Screw	.35



MADE IN U.S.A. — EXCLUSIVELY BY A.P.T.

◆ INDEXABLE TURNING TOOL HOLDERS

FOR USE WITH TPGH INSERTS

- Each tool has precision pockets
- Replaces old style brazed tip tool bits
- Uses inexpensive 1/4" and 3/8" I.C. Triangle inserts



LARGE SHANK SERIES



SMALL SHANK SERIES

A Overall Length	B Shank Size	Insert I.C.	RIGHT HAND	LEFT HAND	Price Each	
			"A" Series 0° Lead Angle	"A" Series 0° Lead Angle		
2-1/2	3/8	1/4	TPAR-6	TPAL-6	22.50	"A" Series 0° Lead Angle
3-1/2	1/2	1/4	TPAR-8	TPAL-8	24.25	
4	5/8	1/4	TPAR-10	TPAL-10	26.75	
6	3/4	3/8	TPAR-12	TPAL-12	34.75	
6	1	3/8	TPAR-16	TPAL-16	40.50	
6	1-1/4	3/8	TPAR-20	TPAL-20	44.50	
A Overall Length	B Shank Width	Insert I.C.	"B" Series 15° Lead Angle	"B" Series 15° Lead Angle	Price Each	
2-1/2	3/8	1/4	TPBR-6	TPBL-6	22.50	
3-1/2	1/2	1/4	TPBR-8	TPBL-8	24.25	
4	5/8	1/4	TPBR-10	TPBL-10	26.75	
6	3/4	3/8	TPBR-12	TPBL-12	34.75	
6	1	3/8	TPBR-16	TPBL-16	40.50	
6	1-1/4	3/8	TPBR-20	TPBL-20	44.50	
A Overall Length	B Shank Width	Insert I.C.	"D" Series 30° Lead Angle	"D" Series 30° Lead Angle	Price Each	
2-1/2	3/8	1/4	TPDR-6	TPDL-6	22.50	
3-1/2	1/2	1/4	TPDR-8	TPDL-8	24.25	
4	5/8	1/4	TPDR-10	TPDL-10	26.75	
6	3/4	3/8	TPDR-12	TPDL-12	34.75	
6	1	3/8	TPDR-16	TPDL-16	40.50	
6	1-1/4	3/8	TPDR-20	TPDL-20	44.50	
A Overall Length	B Shank Width	Insert I.C.	"F" Series Facing Tool	"F" Series Facing Tool	Price Each	
2-1/2	3/8	1/4	TPFR-6	TPFL-6	22.50	
3-1/2	1/2	1/4	TPFR-8	TPFL-8	24.25	
4	5/8	1/4	TPFR-10	TPFL-10	26.75	
6	3/4	3/8	TPFR-12	TPFL-12	34.75	
6	1	3/8	TPFR-16	TPFL-16	40.50	
6	1-1/4	3/8	TPFR-20	TPFL-20	44.50	
A Overall Length	B Shank Width	Insert I.C.	"G" Series 0° Lead Offset	"G" Series 0° Lead Offset	Price Each	
2-1/2	3/8	1/4	TPGR-6	TPGL-6	22.50	
3-1/2	1/2	1/4	TPGR-8	TPGL-8	24.25	
4	5/8	1/4	TPGR-10	TPGL-10	26.75	
6	3/4	3/8	TPGR-12	TPGL-12	34.75	
6	1	3/8	TPGR-16	TPGL-16	40.50	
6	1-1/4	3/8	TPGR-20	TPGL-20	44.50	

Inserts sold separately.

CARBIDE INSERTS



TPGH TRIANGLE — Positive rake ground all over with chip groove on one side

Insert Number	I.C.	Thickness	Radius	Price Each		
				C-2	C-5 & C-6	TiN Coated
TPGH-21.50	1/4	3/32	0	4.75	5.23	6.11
TPGH-21.51	1/4	3/32	1/64	4.75	5.23	6.11
TPGH-21.52	1/4	3/32	1/32	4.75	5.23	6.11
TPGH-321	3/8	1/8	1/64	5.13	5.70	6.95
TPGH-322	3/8	1/8	1/32	5.13	5.70	6.95

REPLACEMENT PARTS

Part No.	Description	Price Each
TF440-195	Torx® drive flat head screw for 1/4" I.C.	1.25
TF832-285	Torx® flat head cap screw for 3/8" I.C.	1.75
CTW-6	Torx® Wrench for TF440-235	1.95
CTW-10	Torx® Wrench for TF832-235	2.45



◆ VERSADDEX

ADJUSTABLE ANGLE TURNING AND CHAMFERING TOOL

0° TO 180°

- Use full width of insert with no chip interference
- Set at any angle from 0° to 180°
- Allows right hand and left hand cutting
- Tool comes complete with C-5 grade insert, and wrenches

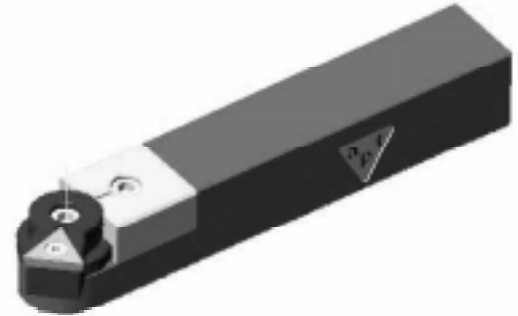

6" OAL		
Tool No.	Shank Size	Price Each
VER12	3/4	139.00
VER16	1	149.00
VER20	1-1/4	165.00

TPGH		Triangle — Positive rake ground all over with chip groove on one side.				
CARBIDE INSERTS						
Insert Number	Radius	I.C.	Thickness	Price Each		
				C-2	C-5 & C-6	TiN Coated*
TPGH-321	1/64	3/8	1/8	5.13	5.70	6.95
TPGH-322	1/32	3/8	1/8	5.13	5.70	6.95

*C-5 & C-6 Grade TiN Coated

REPLACEMENT PARTS LIST		
Part No.	Description	Price Each
TF832-285	Torx® drive flat head screw for insert	1.75
CTW-10	Torx® wrench T10	2.45
CS1032-34	Clamp screw	.35
CSW-2	5/32 allen wrench for clamp screw	.50

◆ MILLDEX

- Mill angles from 5° to 85° with one tool
- Change chamfer angle with a quick adjustment
- Can be held in round tool holder or tool post
- Cutting range from 1/4 to 1-1/4
- Tool comes complete with C5-Grade insert and wrenches



ADJUSTABLE ANGLE MILLING AND CHAMFERING TOOL					
Shank Dia.	Shank Style	Overall Length	Distance Across Flats	Tool No.	Price Each
3/4	Weldon	3-3/4	—	ML750	149.00
3/4	Round with 4 equal flats	6	5/8	MLSL750	169.00
1	Weldon	3-3/4	—	ML1000	159.00
1	Round with 4 equal flats	6	7/8	MLSL1000	189.00
1-1/4	Weldon	3-3/4	—	ML1250	179.00
1-1/4	Round with 4 equal flats	6	1-1/8	MLSL1250	209.00
R8	R8	5-7/8	—	MLR8	199.00

*C-5 & C-6 Grade TiN Coated

TPGH		Triangle — Positive rake ground all over with chip groove on one side.				
CARBIDE INSERTS						
Insert Number	Radius	I.C.	Thickness	Price Each		
				C-2	C-5 & C-6	TiN Coated*
TPGH-321	1/64	3/8	1/8	5.13	5.70	6.95
TPGH-322	1/32	3/8	1/8	5.13	5.70	6.95

*C-5 & C-6 Grade TiN Coated

REPLACEMENT PARTS LIST		
Part No.	Description	Price Each
TF832-285	Torx® drive flat head screw for 3/8" I.C.	1.75
CTW-10	Torx® wrench T10	2.45
CS832-12	Clamp screw	.50
CSW	9/64 allen wrench for clamp screw	.50



MADE IN U.S.A.

◆ CUT-OFF AND GROOVING TOOL SYSTEM

Interchangeable with other brands and other major cut-off and tool system.

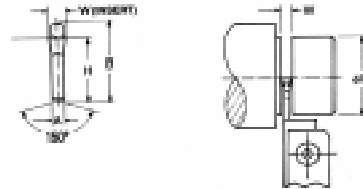
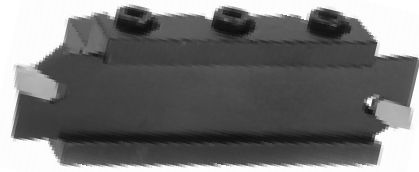

CARBIDE INSERTS				
Width	Insert Number	Price Each		
	0° Face Angle	C-2	C-5/C-6	TiN Coated
NEUTRAL				
.087	ANN-2	5.35	4.95	6.05
.094	ANN-2.4	5.35	4.95	6.05
.120	ANN-3	5.35	4.95	6.05
.160	ANN-4	5.94	5.50	6.70
.187	ANN-4.8	6.43	5.95	7.30
.200	ANN-5	6.43	5.95	7.30
.250	ANN-6	7.02	6.50	7.80
.315	ANN-8	9.45	10.60	11.23
.375	ANN-9	10.75	12.50	14.90

REPLACEMENT PARTS LIST		
Part No.	Description	Price Each
GEX1	Insert Extractor for .087-.250	3.13
GEX2	Insert Extractor for .315-.375	3.13

CARBIDE INSERTS					
Width	Insert Number		Price Each		
	3° Face Angle	8° Face Angle	C-2	C-5/C-6	TiN Coated
RIGHT HAND					
.087	ANR2-3	ANR2-8	6.25	6.25	7.30
.094	ANR2.4-3	ANR2.4-8	5.45	5.45	6.55
.120	ANR3-3	ANR3-8	5.45	5.45	6.55
.160	ANR4-3	ANR4-8	6.05	6.05	7.25
.187	ANR4.8-3	ANR4.8-8	6.50	6.50	7.85
.200	ANR5-3	ANR5-8	6.50	6.50	7.85
.250	ANR6-3	ANR6-8	7.15	7.15	8.65

CARBIDE INSERTS					
Width	Insert Number		Price Each		
	3° Face Angle	8° Face Angle	C-2	C-5/C-6	TiN Coated
LEFT HAND					
.087	ANL2-3	ANL2-8	6.25	6.25	7.80
.094	ANL2.4-3	ANL2.4-8	5.45	5.45	6.55
.120	ANL3-3	ANL3-8	5.45	5.45	6.55
.160	ANL4-3	ANL4-8	6.05	6.05	7.25
.187	ANL4.8-3	ANL4.8-8	6.50	6.50	7.85
.200	ANL5-3	ANL5-8	6.50	6.50	7.85
.250	ANL6-3	ANL6-8	7.15	7.15	8.65

NOTE: All Tin Coated inserts are C5/C6 grade unless otherwise specified

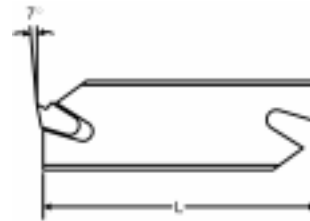

Insert extractor supplied with each blade.

CUT-OFF AND GROOVING BLADES							
Dimensions					Insert Width	Tool Number	Price Each
A	L	H	B	D-Max			
1/16	3-3/8	39/64	3/4	1-1/2	.087 & .094	GIH19-2	47.63
1/16	4-5/16	53/64	1-1/32	2	.087 & .094	GIH26-2	53.73
3/32	4-5/16	53/64	1-1/32	3	.120	GIH26-3	55.75
1/8	4-5/16	53/64	1-1/32	3	.160	GIH26-4	57.13
5/32	4-5/16	53/64	1-1/32	3	.187 & 200	GIH26-5	60.43
13/64	4-5/16	53/64	1-1/32	3	.250	GIH26-6	60.43
1/16*	5-7/8	63/64	1-1/4	2	.087 & .094	GIH32-2	63.02
3/32	5-7/8	63/64	1-1/4	4	.120	GIH32-3	63.02
1/8	5-7/8	63/64	1-1/4	4	.160	GIH32-4	64.48
5/32	5-7/8	63/64	1-1/4	5	.187 & .200	GIH32-5	67.39
13/64	5-7/8	63/64	1-1/4	5	.250	GIH32-6	72.50
17/64	5-7/8	63/64	1-1/4	5.5	.315	GIH32-8	120.96
5/16	5-7/8	63/64	1-1/4	5.5	.375	GIH32-9	120.96

* 1/16 at front end only for clearance. Overall thickness is 3/32.



◆ CUT-OFF AND GROOVING TOOL SYSTEM

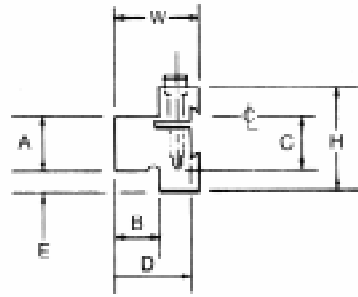

Dimensions								Use Blade Number	Tool Number	Price Each
A	B	C	D	E	H	W	L			
5/8	5/8	5/8	31/32	11/64	1-3/16	1-1/16	3	GIH19-2	GTBN16-2	107.29
5/8	5/8	5/8	1-1/32	7/16	1-1/2	1-3/16	3	GIH26-2,3,4,5,6	GTBN16-5	108.43
3/4	3/4	3/4	1-1/8	21/64	1-17/32	1-5/16	3-3/8	GIH26-2,3,4,5,6	GTBN19-5	117.50
3/4	3/4	3/4	1-1/8	1/2	1-7/8	1-3/8	4	GIH32-2,3,4,5,6,8,9	GTBN19-6	117.50
1	1	1	1-13/32	5/16	1-7/8	1-5/8	4-3/8	GIH32-2,3,4,5,6,8,9	GTBN25-6	119.00
1-1/4	1-1/4	1-1/4	1-11/16	1/8	1-7/8	1-7/8	4-11/16	GIH32-2,3,4,5,6,8,9	GTBN32-6	121.77

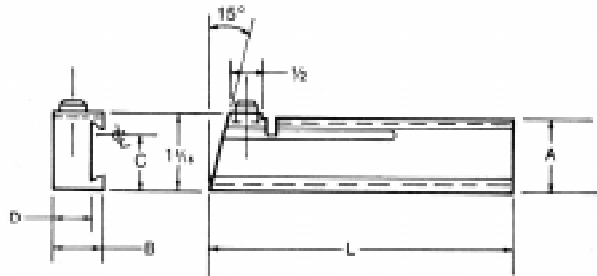

Dimensions					Use Blade Number	Tool Number	Price Each
A	B	C	D	L			
1	3/4	3/4	43/64	4	GIH19-2	GTBR19-2	69.00
1	3/4	3/4	43/64	4	GIH19-2	GTBL19-2	69.00
1-1/4	25/32	1	19/32	4-3/4	GIH26-2,3,4,5,6	GTBR25-6	69.00
1-1/4	25/32	1	19/32	4-3/4	GIH26-2,3,4,5,6	GTBL25-6	69.00

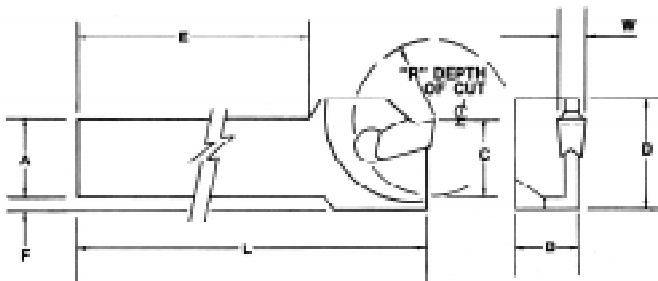

Dimensions										Insert Number	Tool Number		Price Each
A	B	C	D	E	F	L	R	Width	Left Hand		Right Hand		
3/8	3/8	3/8	3/4	2-3/4	3/16	3-3/8	1/2	.087, .094	ANN/R/L-2,2.4	GTHL10-2	GTHR10-2	53.78	
12mm	3/8	15/32	3/4	3-37/64	5/32	4-5/16	19/32	.087, .094	ANN/R/L-2,2.4	GTHL12-2	GTHR12-2	58.75	
1/2	3/8	1/2	3/4	3-37/64	5/32	4-5/16	19/32	.087, .094	ANN/R/L-2,2.4	GTHL12.7-2	GTHR12.7-2	61.54	
1/2	3/8	1/2	3/4	3-37/64	5/32	4-5/16	5/8	.120	ANN/R/L-3	GTHL12.7-3	GTHR12.7-3	61.54	
5/8	3/8	5/8	3/4	3-37/64	0	4-5/16	19/32	.087, .094	ANN/R/L-2,2.4	GTHL16-2	GTHR16-2	62.86	
5/8	1/2	5/8	1	3-29/64	11/64	4-5/16	5/8	.120	ANN/R/L-3	GTHL16-3	GTHR16-3	65.93	
5/8	1/2	5/8	1	3-29/64	11/64	4-5/16	5/8	.160	ANN/R/L-4	GTHL16-4	GTHR16-4	69.66	
3/4	1/2	3/4	1	3-29/64	0	4-5/16	5/8	.087, .094	ANN/R/L-2,2.4	GTHL19-2	GTHR19-2	70.63	
3/4	1/2	3/4	1	3-29/64	0	4-5/16	5/8	.120	ANN/R/L-3	GTHL19-3	GTHR19-3	70.63	
3/4	1/2	3/4	1	3-29/64	1/16	4-5/16	3/4	.160	ANN/R/L-4	GTHL19-4	GTHR19-4	75.44	
3/4	1/2	3/4	1	4-7/16	3/64	4-5/16	3/4	.187, .200	ANN/R/L-4,8.5	GTHL19-5	GTHR19-5	76.74	

SQUARE TOOL BITS

GROUND — BOTH ENDS BEVELED 10°



- LIST NO. 700 — HIGH SPEED STEEL
- LIST NO. 700C — 5% COBALT
- LIST NO. 700SC — 8% SUPER COBALT

STANDARD, LONG AND EXTRA LONG LENGTHS

Size	Overall Length	Price Each		
		List 700	List 700C	List 700SC
1/8	2-1/2	3.70	5.40	—
3/16	2-1/2	3.13	4.25	5.60
1/4	2-1/2	3.24	4.80	6.90
1/4	4	4.99	7.55	—
1/4	6	7.49	11.31	—
1/4	8	9.95	15.02	—
5/16	2-1/2	3.71	5.60	8.80
5/16	4	6.34	9.62	—
5/16	6	8.99	13.57	—
3/8	3	4.93	7.60	11.00
3/8	4	6.92	10.75	—
3/8	6	9.95	15.02	—
3/8	8	13.95	21.06	—
7/16	3-1/2	7.20	11.85	14.75

Size	Overall Length	Price Each		
		List 700	List 700C	List 700SC
1/2	4	10.40	16.90	20.80
1/2	6	15.15	23.07	—
1/2	8	20.80	31.41	—
5/8	4	15.39	—	—
5/8	4-1/2	17.22	26.00	34.00
5/8	8	30.78	46.48	—
3/4	5	24.30	41.00	51.00
3/4	8	28.00	—	—
7/8	6	39.92	65.90	81.50
1	7	58.39	98.00	—
1-1/8	8	89.31	—	—
1-1/4	7	116.24	169.00	—
1-1/4	9	—	—	209.99
1-1/2	10	220.00	—	—

◆ LATHE TURNING TOOL HOLDERS

FOR STANDARD SQUARE TOOL BITS



Each complete with wrench

FOR SQUARE TOOL BITS							
Tool Bit Size	Holder Width	Holder Height	Holder Length	Tool No. Straight Shank	Tool No. Right Hand	Tool No. Left Hand	Price Each
1/8	5/16	1/2	4	TH000S	TH000R	TH000L	17.75
3/16	5/16	3/4	4-1/2	TH00S	TH00R	TH00L	18.50
1/4	3/8	7/8	5	TH0S	TH0R	TH0L	19.75
5/16	1/2	1-1/8	6	TH1S	TH1R	TH1L	22.00
3/8	5/8	1-3/8	7	TH2S	TH2R	TH2L	24.75
7/16	3/4	1-5/8	8	TH3S	TH3R	TH3L	29.50
1/2	7/8	1-3/4	9	TH4S	TH4R	TH4L	38.00
5/8	1	2	11	TH5S	TH5R	TH5L	65.00
3/4	1-1/4	2-1/4	13	TH6S	TH6R	TH6L	85.00

FOR CARBIDE TIPPED TOOL BITS							
Tool Bit Size	Holder Width	Holder Height	Holder Length	Tool No. Straight Shank	Tool No. Right Hand	Tool No. Left Hand	Price Each
1/4	3/8	15/16	6	THT0S	THT0R	THT0L	22.00
5/16	1/2	1-1/4	7	THT1S	THT1R	THT1L	25.00
3/8	5/8	1-1/2	8	THT2S	THT2R	THT2L	29.00
7/16	3/4	1-3/4	9	THT3S	THT3R	THT3L	34.00
1/2	7/8	1-7/8	10	THT4S	THT4R	THT4L	42.00
5/8	1	2-1/8	12	THT5S	THT5R	THT5L	74.00

HIGH SPEED STEEL AND COBALT

RECTANGULAR TOOL BITS



- LIST NO. 701 — HIGH SPEED STEEL
- LIST NO. 701C — COBALT

STANDARD AND LONG LENGTHS

Size	Overall Length	Price Each		Size	Overall Length	Price Each		Size	Overall Length	Price Each	
		List 701	List 701C			List 701	List 701C			List 701	List 701C
3/16 x 2-1/2	6	—	9.79	5/16 x 1	6	—	13.75	1/2 x 1-1/4	7	43.00	—
1/4 x 3/8	3	6.56	—	3/8 x 1/2	4	10.10	15.50	5/8 x 3/4	5	25.00	39.00
1/4 x 1/2	4	8.04	12.00	3/8 x 5/8	4	12.50	16.75	5/8 x 7/8	6	35.00	53.70
1/4 x 3/4	5	12.86	—	3/8 x 3/4	5	14.58	21.90	5/8 x 1	7	43.00	66.40
1/4 x 1	6	20.26	24.00	1/2 x 3/4	4	15.94	22.90	5/8 x 1-1/4	7	52.00	—
5/16 x 7/16	3	7.95	12.15	1/2 x 3/4	6	24.95	34.20	3/4 x 1	6	45.25	—
5/16 x 5/8	4-1/2	9.95	—	1/2 x 1	6	36.00	54.00	3/4 x 1-1/4	7	65.00	—
5/16 x 1	6	11.95	—								

GROUND CUT-OFF BLADES

- LIST NO. 702 — HIGH SPEED STEEL
- LIST NO. 702C — SUPER COBALT



Size	Overall Length	Price Each	
		High Speed List No. 702	Super Cobalt List No. 702C
1/16 x 11/16	5	18.80	—
1/16 x 13/16	6	19.90	29.90
5/64 x 1/2	4-1/2	16.99	—
3/32 x 3/16	6	15.99	25.99
3/32 x 1/2	4-1/2	14.30	24.60
3/32 x 5/8	5	16.20	27.54
3/32 x 13/16	6	19.90	29.90
3/32 x 1	6-1/2	21.90	30.90
1/8 x 3/4	6	20.70	26.40
1/8 x 13/16	6	22.90	—

Size	Overall Length	Price Each	
		High Speed List No. 702	Super Cobalt List No. 702C
1/8 x 7/8	6	24.30	32.00
1/8 x 1	6-1/2	25.90	—
5/32 x 13/16	6	26.00	36.00
3/16 x 13/16	8	24.30	—
3/16 x 1	8	29.00	41.25
3/16 x 1-1/8	7	—	46.50
1/4 x 13/16	6	36.00	—
1/4 x 1-1/8	7	—	50.25
1/4 x 1-1/4	7	38.50	54.00
1/4 x 1-3/8	7	—	58.00

◆ CUT-OFF BLADE TOOL HOLDERS

Complete with wrench

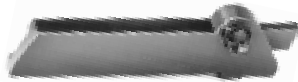

Cut-Off Blade Size	Holder Width	Holder Height	Holder Length	Tool No. Straight Shank	Tool No. Right Hand	Tool No. Left Hand	Price Each
3/32 x 1/2	5/16	3/4	4-1/2	TH29S	TH29R	TH29L	14.90
3/32 x 5/8	3/8	7/8	5	TH30S	TH30R	TH30L	17.75
1/8 x 3/4	1/2	1-1/8	6	TH31S	TH31R	TH31L	22.00
1/8 x 7/8	5/8	1-3/8	7	TH32S	TH32R	TH32L	26.50
3/16 x 1	3/4	1-5/8	8	TH33S	TH33R	TH33L	36.00
3/16 x 1-1/8	7/8	1-3/4	9	TH34S	TH34R	TH34L	49.00
1/4 x 1-3/8	1	2	10	TH35S	TH35R	TH35L	65.00

ROUND TOOL BITS

- LIST NO. 704 — HIGH SPEED STEEL
- LIST NO. 704C — SUPER COBALT



Size	Overall Length	Price Each	
		List No. 704	List No. 704C
1/8	2-3/4	4.25	7.65
5/32	3-1/8	3.24	—
3/16	3-1/2	5.00	9.00
1/4	4	7.60	13.68
5/16	4-1/2	9.80	17.64
3/8	5	12.00	21.75
7/16	5-1/2	15.00	27.00
1/2	6	18.00	32.40
9/16	6	23.00	41.40
5/8	6	28.00	50.40
3/4	6	56.00	100.80

HIGH SPEED STEEL AND SUPER COBALT

"P" TYPE CUT-OFF BLADES T-SHAPED

- LIST NO. 703 — HIGH SPEED STEEL
- LIST NO. 703C — SUPER COBALT

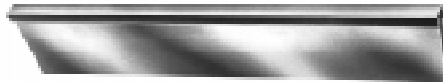

This style blade produces a chip narrower than the blade itself and is suited for cutting off, grooving and similar operations. Increased clearance angles on each side of the blade reduces friction and the narrow design conserves material being cut and reduces the heat generated when cutting.

Width	Height	Overall Length	Blade No.	Price Each	
				List No. 703	List No. 703C
.040	1/2	3-1/2	P1N	15.30	19.50
1/16	1/2	4-1/2	P1	14.70	19.90
5/64	1/2	4-1/2	P2N	16.16	21.00
3/32	1/2	4-1/2	P2	16.16	21.00
1/8	1/2	4-1/2	P3S	16.70	21.50
3/32	11/16	5	P3N	17.10	21.50
1/8	11/16	5	P3	17.30	23.00
5/32	11/16	5	P4	19.85	27.50
3/16	11/16	5	P5S	22.00	32.00
1/8	3/4	5	P3W	17.30	32.00

Width	Height	Overall Length	Blade No.	Price Each	
				List No. 703	List No. 703C
5/32	3/4	5	P4W	22.00	32.00
3/16	3/4	5	P5W	24.14	36.00
1/8	7/8	6	P5X	21.22	32.00
5/32	7/8	6	P5N	24.86	36.00
3/16	7/8	6	P5	24.55	36.00
1/4	7/8	6	P6	29.48	44.00
1/8	1-1/8	6-1/2	P8X	36.75	53.50
5/32	1-1/8	6-1/2	P8N	41.00	55.00
3/16	1-1/8	6-1/2	P8	36.75	53.50
1/4	1-1/8	6-1/2	P9	41.00	55.00

◆ CARBIDE TIPPED TOOL BITS



For turning on the outside of the part.

Please specify grade when ordering C-2 Cast Iron and nonferrous materials or C-5/C-6 Steel and ferrous materials.



For turning on the outside of the part.

AR AND AL STYLES

BR AND BL STYLES

STRAIGHT TURNING TOOLS

Square Shank	Overall Length	Tool No. Right Hand	Tool No. Left Hand	Price Each
1/4	2	AR4	AL4	4.15
5/16	2-1/4	AR5	AL5	4.40
3/8	2-1/2	AR6	AL6	4.40
7/16	3	AR7	AL7	4.50
1/2	3-1/2	AR8	AL8	4.87
5/8	4	AR10	AL10	6.95
3/4	4-1/2	AR12	AL12	8.90
1	7	AR16	AL16	15.75

15° LEAD ANGLE TURNING TOOLS

Square Shank	Overall Length	Tool No. Right Hand	Tool No. Left Hand	Price Each
1/4	2	BR4	BL4	4.15
5/16	2-1/4	BR5	BL5	4.40
3/8	2-1/2	BR6	BL6	4.40
7/16	3	BR7	BL7	4.50
1/2	3-1/2	BR8	BL8	5.20
5/8	4	BR10	BL10	6.95
3/4	4-1/2	BR12	BL12	9.25
1	7	BR16	BL16	15.50



D STYLE

80° INCLUDED ANGLE

For chamfering corners on the outside or inside of the part.



C STYLE

For chamfering or special designs.



E STYLE

60° INCLUDED ANGLE

For threading on the outside of the part.

POINTED NOSE TOOLS

Square Shank	Overall Length	Tool No.	Price Each
1/4	2	D4	4.07
5/16	2-1/4	D5	4.30
3/8	2-1/2	D6	4.30
7/16	3	D7	4.45
1/2	3-1/2	D8	5.20
5/8	4	D10	7.14
3/4	4-1/2	D12	9.55
1	7	D16	14.35

SQUARE NOSE TOOLS

Square Shank	Overall Length	Tool No.	Price Each
1/4	2	C4	4.07
5/16	2-1/4	C5	4.30
3/8	2-1/2	C6	4.40
7/16	3	C7	4.60
1/2	3-1/2	C8	5.55
5/8	4	C10	7.70
3/4	4-1/2	C12	10.90
1	7	C16	18.00

THREADING TOOLS

Square Shank	Overall Length	Tool No.	Price Each
1/4	2	E4	4.20
5/16	2-1/4	E5	4.40
3/8	2-1/2	E6	4.40
7/16	3	E7	4.50
1/2	3-1/2	E8	5.55
5/8	4	E10	6.84
3/4	4-1/2	E12	9.55
1	7	E16	15.50



FR AND FL STYLES

For facing on the outside of the part—offset head provides additional side clearance.



GR AND GL STYLES

For turning on the outside of the part—offset head provides additional side clearance.

OFFSET END-CUTTING TOOLS

Square Shank	Overall Length	Tool No. Right Hand	Tool No. Left Hand	Price Each
1/2	3-1/2	FR8	FL8	9.50
5/8	4	FR10	FL10	10.75
3/4	4-1/2	FR12	FL12	12.50
1	7	FR16	FL16	18.50

OFFSET SIDE-CUTTING TOOLS

Square Shank	Overall Length	Tool No. Right Hand	Tool No. Left Hand	Price Each
1/2	3-1/2	GR8	GL8	9.50
5/8	4	GR10	GL10	10.75
3/4	4-1/2	GR12	GL12	12.50
1	7	GR16	GL16	18.50



CTR AND CTL STYLES

For grooving, trepanning and cut-off.

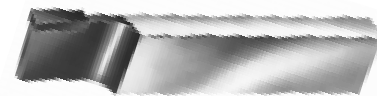

CUT-OFF TOOLS

Tip Width	Shank Width	Shank Height	Overall Length	Tool No. Right Hand	Tool No. Left Hand	Price Each
1/8	1/2	1	5	CTR11	CTL11	11.75
3/16	1/2	1	5	CTR22	CTL22	12.00
1/4	1/2	1	5	CTR33	CTL33	12.25
5/16	1/2	1	5	CTR44	CTL44	12.25
3/8	5/8	1-1/4	5	CTR55	CTL55	14.80

◆ CARBIDE TIPPED TOOL BITS

Please specify grade when ordering C-2 Cast Iron for nonferrous materials or C-5/C-6 Steel for ferrous materials.



ER AND EL STYLES

OFFSET THREADING				
Square Shank	Overall Length	Tool No. Right Hand	Tool No. Left Hand	Price Each
1/4	2	ER4	EL4	6.95
5/16	2-1/4	ER5	—	7.05
3/8	2-1/2	ER6	EL6	7.05
1/2	3-1/2	ER8	EL8	7.90

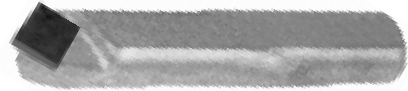

TRC AND TRE STYLES

ROUND SHANK BORING			
Round Shank	Overall Length	Tool No.	Price Each
.312	1-1/2	TRC5	5.80
.312	1-1/2	TRE5	5.80

TSA TSC AND TSE STYLES



- **TSA** for boring to a square shoulder in 90° boring bars .
- **TSC** for boring to a square shoulder in 30° boring bars or internal chamfering.
- **TSE** for boring to a square shoulder in 45° boring bars or boring with a 15° lead angle in 30° boring bar.

SQUARE SHANK BORING			
Square Shank	Overall Length	Tool No.	Price Each
5/16	1-1/2	TSA-5	6.70
3/8	1-3/4	TSA-6	6.70
1/2	2-1/2	TSA-8	7.40
5/16	1-1/2	TSC-5	6.70
3/8	1-3/4	TSC-6	6.70
1/2	2-1/2	TSC-8	7.40

SQUARE SHANK BORING			
Square Shank	Overall Length	Tool No.	Price Each
5/8	3	TSC-10	10.80
3/4	3-1/2	TSC-12	17.50
5/16	1-1/2	TSE-5	6.70
3/8	1-3/4	TSE-6	6.70
1/2	2-1/2	TSE-8	7.40
5/8	3	TSE-10	10.80

◆ CARBIDE TIPPED TOOL BIT SETS

Please specify grade when ordering C-2 Cast Iron for nonferrous materials or C-5/C-6 Steel for ferrous materials.

38 Piece Set

Size	Set No.	Price Each
1/4	CTBS-14	129.00
5/16	CTBS-516	139.00
3/8	CTBS-38	139.00
1/2	CTBS-12	159.00

Each set includes:

- 8 Pieces Each: AR style (Right Hand) AL style (Left Hand)
- 4 Pieces Each: BR style (Right Hand) BL style (Left Hand)
- 4 Pieces Each: C style
- 4 Pieces Each: D style
- 6 Pieces Each: E style

◆ STRAIGHT AND BENT TAIL LATHE DOGS



LATHE DOGS			
Size	Straight Tool No.	Bent Tool No.	Price Each
1/2	THLD50	THBD50	2.75
3/4	THLD75	THBD75	3.99
1	THLD100	THBD100	5.95
1-1/4	THLD125	THBD125	6.90
1-1/2	THLD150	THBD150	7.85
1-3/4	THLD175	THBD175	8.30
2	THLD200	THBD200	9.67
2-1/2	THLD250	THBD250	17.50
3	THLD300	THBD300	22.50
4	THLD400	THBD400	33.85
5	THLD500	THBD500	43.30
6	THLD600	THBD600	49.90

◆ GRINDING CARRIERS



CARRIERS		
Size	Tool No.	Price Each
1/4	THG25	4.30
3/8	THG375	4.50
1/2	THG500	4.60
5/8	THG625	4.95
3/4	THG750	5.50
1	THG1000	5.90
1-1/4	THG1250	7.75
1-1/2	THG1500	8.85
1-3/4	THG1750	10.50
2	THG2000	11.90
2-1/2	THG2500	13.40
3	THG3000	14.85



MADE IN U.S.A.

CARBIDE INSERTS

Please order in package quantity, 10 inserts in a package.

TiN Coated is C5/C6 grade unless otherwise specified

TPG TRIANGLE — POSITIVE RAKE GROUND ALL OVER

Insert Number	I.C.	Thickness	Radius	Price Each		
				C-2	C-5 & C-6	TiN Coated
TPG-220	1/4	1/8	0	3.60	3.80	4.61
TPG-221	1/4	1/8	1/64	4.14	4.37	5.30
TPG-222	1/4	1/8	1/32	4.14	4.37	5.30
TPG-223	1/4	1/8	3/64	4.14	4.37	5.30
TPG-320	3/8	1/8	0	4.89	5.18	6.21
TPG-321	3/8	1/8	1/64	4.89	5.18	6.21
TPG-322	3/8	1/8	1/32	4.89	5.18	6.21
TPG-323	3/8	1/8	3/64	4.89	5.18	6.21
TPG-324	3/8	1/8	1/16	4.89	5.18	6.21
TPG-430	1/2	3/16	0	5.98	6.50	7.60
TPG-431	1/2	3/16	1/64	5.98	6.50	7.60
TPG-432	1/2	3/16	1/32	5.98	6.50	7.60
TPG-433	1/2	3/16	3/64	5.98	6.50	7.60
TPG-434	1/2	3/16	1/16	5.98	6.50	7.60
TPG-542	5/8	1/4	1/32	9.90	10.85	12.95
TPG-543	5/8	1/4	3/64	9.90	10.85	12.95
TPG-544	5/8	1/4	1/16	9.90	10.85	12.95

TNMG TRIANGLE — NEGATIVE RAKE WITH CHIP CONTROL

Insert Number	I.C.	Thickness	Radius	Price Each		
				C-2	C-5 & C-6	TiN Coated
TNMG-221	1/4	1/8	1/64	1.95	2.15	2.85
TNMG-222	1/4	1/8	1/32	1.95	2.15	2.85
TNMG-321	3/8	1/8	1/64	2.38	2.56	3.23
TNMG-322	3/8	1/8	1/32	2.38	2.56	3.23
TNMG-323	3/8	1/8	3/64	2.38	2.56	3.23
TNMG-324	3/8	1/8	1/16	2.38	2.56	3.23
TNMG-331	3/8	3/16	1/64	2.77	3.15	3.86
TNMG-332	3/8	3/16	1/32	2.77	3.15	3.86
TNMG-333	3/8	3/16	3/64	2.77	3.15	3.86
TNMG-431	1/2	3/16	1/64	3.94	4.46	5.20
TNMG-432	1/2	3/16	1/32	3.94	4.46	5.20
TNMG-433	1/2	3/16	3/64	3.94	4.46	5.20
TNMG-434	1/2	3/16	1/16	3.94	4.46	5.20
TNMG-438	1/2	3/16	1/8	3.94	4.46	5.20
TNMG-542	5/8	1/4	1/32	6.88	8.03	10.10
TNMG-543	5/8	1/4	3/64	6.88	8.03	10.10
TNMG-544	5/8	1/4	1/16	6.88	8.03	10.10
TNMG-666*	3/4	3/8	3/32	12.26	14.23	16.75

*5pcs per pkg

TNG TRIANGLE — NEGATIVE RAKE GROUND ALL OVER

Insert Number	I.C.	Thickness	Radius	Price Each		
				C-2	C-5 & C-6	TiN Coated
TNG-221	1/4	1/8	1/64	2.62	2.81	4.04
TNG-222	1/4	1/8	1/32	2.62	2.81	4.04
TNG-321	3/8	1/8	1/64	3.30	3.64	4.97
TNG-322	3/8	1/8	1/32	3.30	3.64	4.97
TNG-323	3/8	1/8	3/64	3.30	3.64	4.97
TNG-324	3/8	1/8	1/16	3.30	3.64	4.97
TNG-332	3/8	3/16	1/32	3.94	4.37	5.83
TNG-333	3/8	3/16	3/64	3.94	4.37	5.83
TNG-432	1/2	3/16	1/32	5.49	6.05	8.05
TNG-433	1/2	3/16	3/64	5.49	6.05	8.05
TNG-434	1/2	3/16	1/16	5.49	6.05	8.05
TNG-544	5/8	1/4	1/16	8.48	9.67	13.50

TNMA TRIANGLE — NEGATIVE RAKE LAPPED TOP AND BOTTOM WITH HOLE

Insert Number	I.C.	Thickness	Radius	Price Each		
				C-2	C-5 & C-6	TiN Coated
TNMA-222	1/4	1/8	1/32	1.43	1.71	2.59
TNMA-322	3/8	1/8	1/32	1.96	2.13	3.08
TNMA-323	3/8	1/8	3/64	1.96	2.13	3.08
TNMA-432	1/2	3/16	1/32	3.78	4.26	5.26
TNMA-433	1/2	3/16	3/64	3.78	4.26	5.26
TNMA-434	1/2	3/16	1/16	3.78	4.26	5.26
TNMA-438	1/2	3/16	1/8	3.78	4.26	5.26
TNMA-542	5/8	1/4	1/32	6.77	7.87	9.65
TNMA-544	5/8	1/4	1/16	6.77	7.87	9.65
TNMA-666*	3/4	3/8	3/32	11.88	13.95	17.15

*5pc per pkg

TPU TRIANGLE — POSITIVE RAKE GROUND TOP AND BOTTOM

Insert Number	I.C.	Thickness	Radius	Price Each		
				C-2	C-5 & C-6	TiN Coated
TPU-222	1/4	1/8	1/32	2.38	2.80	3.55
TPU-321	3/8	1/8	1/64	3.20	3.45	4.65
TPU-322	3/8	1/8	1/32	3.20	3.45	4.65
TPU-323	3/8	1/8	3/64	3.20	3.45	4.65
TPU-431	1/2	3/16	1/64	5.15	5.55	6.68
TPU-432	1/2	3/16	1/32	5.15	5.55	6.68
TPU-433	1/2	3/16	3/64	5.15	5.55	6.68
TPU-434	1/2	3/16	1/16	5.15	5.55	6.68
TPU-543	5/8	1/4	3/64	9.40	9.90	11.35
TPU-544	5/8	1/4	1/16	9.40	9.90	11.35

TNMP TRIANGLE — NEGATIVE RAKE 5° POSITIVE

Insert Number	I.C.	Thickness	Radius	Price Each	
				C-5 & C-6	TiN Coated
TNMP-321	3/8	1/8	1/64	3.30	4.10
TNMP-322	3/8	1/8	1/32	3.30	4.10
TNMP-323	3/8	1/8	3/64	3.30	4.10
TNMP-331	3/8	3/16	1/64	3.75	4.55
TNMP-332	3/8	3/16	1/32	3.75	4.55
TNMP-333	3/8	3/16	3/64	3.75	4.55
TNMP-431	1/2	3/16	1/64	5.32	6.19
TNMP-432	1/2	3/16	1/32	5.32	6.19

TNU TRIANGLE — NEGATIVE RAKE GROUND TOP AND BOTTOM

Insert Number	I.C.	Thickness	Radius	Price Each		
				C-2	C-5 & C-6	TiN Coated
TNU-222	1/4	1/8	1/32	1.47	1.60	2.60
TNU-322	3/8	1/8	1/32	1.95	2.26	3.38
TNU-323	3/8	1/8	3/64	1.95	2.26	3.38
TNU-332	3/8	3/16	1/32	2.46	2.91	4.05
TNU-333	3/8	3/16	3/64	2.46	2.91	4.05
TNU-432	1/2	3/16	1/32	3.60	4.30	5.89
TNU-433	1/2	3/16	3/64	3.60	4.30	5.89
TNU-434	1/2	3/16	1/16	3.60	4.30	5.89
TNU-544	5/8	1/4	1/16	6.60	7.95	9.95

TPGH TRIANGLE — POSITIVE RAKE GROUND ALL OVER WITH CHIP GROOVE ON ONE SIDE

Insert Number	I.C.	Thickness	Radius	Price Each		
				C-2	C-5 & C-6	TiN Coated
TPGH-21.50	1/4	3/32	0	4.75	5.23	6.11
TPGH-21.51	1/4	3/32	1/64	4.75	5.23	6.11
TPGH-21.52	1/4	3/32	1/32	4.75	5.23	6.11
TPGH-321	3/8	1/8	1/64	5.13	5.70	6.95
TPGH-322	3/8	1/8	1/32	5.13	5.70	6.95

TPC TRIANGLE — POSITIVE RAKE GROUND ALL OVER WITH WIPING FLATS ON THREE CORNERS

Insert Number	I.C.	Thickness	Price Each		
			C-2	C-5 & C-6	TiN Coated
TPC-32ZR	3/8	1/8	4.80	4.98	5.85

TNUC TRIANGLE — NEGATIVE RAKE BRAKE TURNING INSERT

Insert Number	I.C.	Thickness	Radius	Hole Size	Price Each
					C-2
TNUC-21.52	1/4	3/32	1/32	.136	2.95
TNUC-222	1/4	1/8	1/32	.136	3.13

CARBIDE INSERTS

Please order in package quantity. 10 inserts in a package.



TPMA-NV TRIANGLE— POSITIVE RAKE 60° V-THREAD

Insert Number	I.C.	Thickness	Hole Size	Price Each		
				C-2	C-5 & C-6	TiN Coated*
TPMA-32NV	3/8	.125	.150	9.81	10.32	11.66
TPMA-43NV	1/2	.188	.203	11.40	11.97	13.11

TNMA-NV TRIANGLE— NEUTRAL RAKE 60° V-THREAD

Insert Number	I.C.	Thickness	Hole Size	Price Each		
				C-2	C-5 & C-6	TiN Coated*
TNMA-32NV	3/8	.125	.150	8.49	8.75	10.08
TNMA-43NV	1/2	.188	.203	10.22	10.71	12.27

TPMC-NV TRIANGLE— POSITIVE RAKE 60° V-THREAD

Insert Number	I.C.	Thickness	Hole Size	Price Each		
				C-2	C-5 & C-6	TiN Coated*
TPMC-32NV	3/8	.125	.150	9.81	10.32	11.66
TPMC-43NV	1/2	.188	.203	11.40	11.97	13.11

TNMC-NV TRIANGLE— NEUTRAL RAKE 60° V-THREAD

Insert Number	I.C.	Thickness	Hole Size	Price Each		
				C-2	C-5 & C-6	TiN Coated*
TNMC-32NV	3/8	.125	.150	8.49	8.75	10.08
TNMC-43NV	1/2	.188	.203	10.22	10.71	12.27

SPG SQUARE — POSITIVE RAKE GROUND ALL OVER

Insert Number	I.C.	Thickness	Radius	Price Each		
				C-2	C-5 & C-6	TiN Coated*
SPG-321	3/8	1/8	1/64	4.31	4.52	5.24
SPG-322	3/8	1/8	1/32	4.31	4.52	5.24
SPG-323	3/8	1/8	3/64	4.31	4.52	5.24
SPG-420	1/2	1/8	0	4.75	5.12	5.80
SPG-421	1/2	1/8	1/64	4.75	5.12	5.80
SPG-422	1/2	1/8	1/32	4.75	5.12	5.80
SPG-423	1/2	1/8	3/64	4.75	5.12	5.80
SPG-424	1/2	1/8	1/16	4.75	5.12	5.80
SPG-432	1/2	3/16	1/32	5.47	6.16	7.54
SPG-433	1/2	3/16	3/64	5.47	6.16	7.54
SPG-632	3/4	3/16	1/32	7.93	8.75	10.30
SPG-633	3/4	3/16	3/64	7.93	8.75	10.30
SPG-634	3/4	3/16	1/16	7.93	8.75	10.30

SNG SQUARE — NEGATIVE RAKE GROUND ALL OVER

Insert Number	I.C.	Thickness	Radius	Price Each		
				C-2	C-5 & C-6	TiN Coated*
SNG-321	3/8	1/8	1/64	2.99	3.29	3.85
SNG-322	3/8	1/8	1/32	2.99	3.29	3.85
SNG-323	3/8	1/8	3/64	2.99	3.29	3.85
SNG-332	1/8	3/16	1/32	—	3.86	4.60
SNG-422	1/2	1/8	1/32	3.80	4.08	4.71
SNG-423	1/2	1/8	3/64	3.80	4.08	4.71
SNG-424	1/2	1/8	1/16	3.80	4.08	4.71
SNG-432	1/2	3/16	1/32	4.60	4.99	5.75
SNG-433	1/2	3/16	3/64	4.60	4.99	5.75
SNG-434	1/2	3/16	1/16	4.60	4.99	5.75
SNG-632	3/4	3/16	1/32	7.20	8.25	9.46
SNG-633	3/4	3/16	3/64	7.20	8.25	9.46
SNG-634	3/4	3/16	1/16	7.20	8.25	9.46

SPU SQUARE — POSITIVE RAKE GROUND TOP AND BOTTOM

Insert Number	I.C.	Thickness	Radius	Price Each		
				C-2	C-5 & C-6	TiN Coated*
SPU-322	3/8	1/8	1/32	2.89	3.46	4.05
SPU-421	1/2	1/8	1/64	4.10	4.46	5.13
SPU-422	1/2	1/8	1/32	4.10	4.46	5.13
SPU-423	1/2	1/8	3/64	4.10	4.46	5.13
SPU-632	3/4	3/16	1/32	7.78	8.63	9.99
SPU-633	3/4	3/16	3/64	7.78	8.63	9.99
SPU-634	3/4	3/16	1/16	7.78	8.63	9.99

SNU SQUARE — NEGATIVE RAKE GROUND TOP AND BOTTOM

Insert Number	I.C.	Thickness	Radius	Price Each		
				C-2	C-5 & C-6	TiN Coated*
SNU-322	3/8	1/8	1/32	1.90	2.07	2.86
SNU-422	1/2	1/8	1/32	2.63	2.97	3.57
SNU-423	1/2	1/8	3/64	2.63	2.97	3.57
SNU-424	1/2	1/8	1/16	2.63	2.97	3.57
SNU-432	1/2	3/16	1/32	3.23	3.78	4.36
SNU-433	1/2	3/16	3/64	3.23	3.78	4.36
SNU-434	1/2	3/16	1/16	3.23	3.78	4.36
SNU-633	3/4	3/16	3/64	5.79	6.80	7.95
SNU-634	3/4	3/16	1/16	5.79	6.80	7.95

SNMA SQUARE — NEGATIVE RAKE LAPPED TOP AND BOTTOM WITH HOLE

Insert Number	I.C.	Thickness	Radius	Price Each		
				C-2	C-5 & C-6	TiN Coated*
SNMA-322	3/8	1/8	1/32	1.62	1.84	2.78
SNMA-432	1/2	3/16	1/32	3.13	3.56	4.41
SNMA-433	1/2	3/16	3/64	3.13	3.56	4.41
SNMA-543	5/8	1/4	3/64	4.73	5.43	6.72
SNMA-633	3/4	1/4	3/64	4.88	5.72	6.97
SNMA-643	3/4	1/4	3/64	6.40	7.46	9.16
SNMA-644	3/4	1/4	1/16	6.40	7.46	9.16
SNMA-866	1	3/8	3/32	15.93	18.63	23.07

SPC SQUARE — POSITIVE RAKE GROUND ALL OVER W/ WIPING FLATS ON FOUR CORNERS

Insert Number	I.C.	Thickness	Price Each		
			C-2	C-5 & C-6	TiN Coated*
SPC-42ZR	1/2	1/8	4.95	5.30	6.35

SNMG SQUARE — NEGATIVE RAKE WITH CHIP CONTROL

Insert Number	I.C.	Thickness	Radius	Price Each		
				C-2	C-5 & C-6	TiN Coated*
SNMG-322	3/8	1/8	1/32	2.26	2.50	3.11
SNMG-323	3/8	1/8	3/64	2.26	2.50	3.11
SNMG-432	1/2	3/16	1/32	3.43	3.94	4.83
SNMG-433	1/2	3/16	3/64	3.43	3.94	4.83
SNMG-434	1/2	3/16	1/16	3.43	3.94	4.83
SNMG-543	5/8	1/4	3/64	5.24	6.04	6.93
SNMG-642	3/4	1/4	1/32	7.72	8.17	10.56
SNMG-643	3/4	1/4	3/64	7.72	8.17	10.56
SNMG-644	3/4	1/4	1/16	7.72	8.17	10.56
SNMG-866	1	3/8	3/32	16.86	19.79	23.37

SEC SQUARE — 20° POSITIVE RAKE GROUND ALL OVER

Insert Number	I.C.	Thickness	Price Each		
			C-2	C-5 & C-6	TiN Coated*
SEC-422	1/2	1/8	6.18	6.50	7.40
SEC-422J	1/2	1/8	7.10	7.58	8.48

SPGH SQUARE — POSITIVE RAKE GROUND ALL OVER CHIP GROOVE ONE SIDE

Insert Number	I.C.	Thickness	Radius	Price Each		
				C-2	C-5 & C-6	TiN Coated*
SPGH-432	1/2	1/32	3/64	9.45	9.95	11.95
SPGH-433	1/2	3/16	3/64	9.45	9.95	11.95

*C-5 & C-6 Grade TiN Coated



MADE IN U.S.A.

CARBIDE INSERTS

Please order in package quantity. 10 inserts in a package.

TiN Coated is C5/C6 grade unless otherwise specified



RNG

ROUND — NEGATIVE RAKE
GROUND ALL OVER

Insert Number	Dia. ± .001	Thickness	Price Each		
			C-2	C-5 & C-6	TiN Coated
RNG-32	3/8	1/8	2.81	3.07	3.64
RNG-42	1/2	1/8	3.56	3.85	4.51
RNG-43	1/2	3/16	4.51	4.94	5.74



RNMA

ROUND — NEGATIVE RAKE
LAPPED TOP AND BOTTOM
WITH HOLE

Insert Number	Dia. ± .001	Thickness	Price Each		
			C-2	C-5 & C-6	TiN Coated
RNMA-32	3/8	1/8	1.71	1.96	2.83
RNMA-43	1/2	3/16	2.26	2.73	3.63
RNMA-64	3/4	1/4	5.12	5.94	7.50
RNMA-86*	1	3/8	12.27	14.19	17.38
RNMA-106*	1-1/4	3/8	17.93	20.74	25.69

*5pcs per pkg



DNMG

55° DIAMOND — NEGATIVE RAKE
WITH CHIP CONTROL

Insert Number	I.C.	Thickness	Radius	Price Each	
				C-5 & C-6	TiN Coated
DNMG-431	1/2	3/16	1/64	6.12	6.55
DNMG-432	1/2	3/16	1/32	6.12	6.55
DNMG-532	5/8	3/16	1/32	7.99	8.69
DNMG-533	5/8	3/16	3/64	7.99	8.69
DNMG-542	5/8	1/4	1/32	9.70	10.70
DNMG-543	5/8	1/4	3/64	9.70	10.70



CNMG

80° DIAMOND — NEGATIVE
LAPPED WITH HOLE AND
CAST CHIPBREAKER

Insert Number	I.C.	Thickness	Radius	Price Each		
				C-2	C-5 & C-6	TiN Coated
CNMG-431	1/2	3/16	1/64	3.45	3.81	4.35
CNMG-432	1/2	3/16	1/32	3.45	3.81	4.35
CNMG-433	1/2	3/16	3/64	3.45	3.81	4.35
CNMG-542	5/8	1/4	1/32	—	6.36	8.19
CNMG-543	5/8	1/4	3/64	—	6.36	8.19
CNMG-643	3/4	1/4	3/64	—	8.24	10.83
CNMG-644	3/4	1/4	1/16	—	8.24	10.83



CTA

87° PARALLELOGRAMS
ALL SURFACES GROUND —
POSITIVE RAKE

Insert Number	Please Specify Radii							I.C.	Thickness	Price Each		
	0	1/64	1/32	1/16	3/32	1/8	—			C-2	C-5	TiN Coated
CTA-2*	0	1/64	1/32	1/16	3/32	1/8	—	.355	5/32	5.63	5.97	6.78
CTA-4	0	1/64	1/32	1/16	3.32	1/8	—	.460	3/16	6.92	7.15	8.13
CTA-6	—	—	1/32	1/16	3/32	1/8	—	.685	3/16	9.85	10.45	13.81
CTA-8	—	—	1/32	1/16	3/32	1/8	1/4	.750	3/16	11.28	12.43	14.47

* 88° Parallelogram



CHIPBREAKERS

Part Number	I.C.	Effective Width	Price Each
CBT12	3/8	.129	3.19
CBT12N	3/8	.080	3.19
CBT12F	3/8	.056	3.19
CBT16	1/2	.190	3.56

Part Number	I.C.	Effective Width	Price Each
CBT16N	1/2	.100	4.16
CBT16F	1/2	.054	4.27
CBT20	5/8	.190	4.59
CBT20N	5/8	.100	4.80



RPG

ROUND — POSITIVE RAKE
GROUND ALL OVER

Insert Number	Dia. ± .001	Thickness	Price Each		
			C-2	C-5 & C-6	TiN Coated
RPG-42	1/2	1/8	4.40	4.95	5.90



RNMG

ROUND — NEGATIVE RAKE
WITH CHIP CONTROL

Insert Number	Dia. ± .001	Thickness	Price Each		
			C-2	C-5 & C-6	TiN Coated
RNMG-32	3/8	1/8	1.93	2.25	2.88
RNMG-43	1/2	3/16	2.72	3.01	4.05
RNMG-64	3/4	1/4	5.78	6.59	8.72
RNMG-86*	1	3/8	12.95	14.85	18.63

*5pcs per pkg



VNMG

35° DIAMOND — NEGATIVE RAKE
WITH CHIP CONTROL

Insert Number	I.C.	Thickness	Radius	Price Each	
				C-5 & C-6	TiN Coated
VNMG-331	3/8	3/16	1/64	5.75	6.20
VNMG-332	3/8	3/16	1/32	5.75	6.20
VNMG-333	3/8	3/16	3/64	5.75	6.20
VNMG-431	1/2	3/16	1/64	6.63	7.68
VNMG-432	1/2	3/16	1/32	6.63	7.68



CNMP

80° DIAMOND — 5° POSITIVE
LAPPED WITH HOLE
AND CAST CHIPBREAKER

Insert Number	I.C.	Thickness	Radius	Price Each	
				C-5 & C-6	TiN Coated
CNMP-431	1/2	3/16	1/64	4.70	5.40
CNMP-432	1/2	3/16	1/32	4.70	5.40
CNMP-642	3/4	1/4	1/32	10.45	12.02
CNMP-643	3/4	1/4	3/64	10.45	12.02



TT INSERTS

11° POSITIVE LAPPED
WITH HOLE AND CAST
CHIPBREAKER

Insert Number	I.C.	Thickness	Radius	Price Each		
				C-2	C-5 & C-6	TiN Coated
TT-221	1/4	1/8	.015	3.35	3.85	4.52
TT-222	1/4	1/8	.032	3.35	3.85	4.52
TT-321	3/8	1/8	.015	4.17	4.85	5.52
TT-322	3/8	1/8	.032	4.17	4.85	5.52



SHIMS

Part Number	Dimensions		Positive or Negative Width	Screw Size	Price Each
	I.C.	T			
SHIM41	3/8	1/8	P	4-40	3.75
SHIM48	3/8	3/16	N	4-40	3.99
SHIM26	1/2	1/8	N	8-32	4.31
SHIM37	1/2	1/8	P	8-32	4.59

◆ RECESSING TOOLS



HIGH SPEED AND CARBIDE TIPPED

- Maximum Reach — 3/8"
- Length of Shank — 1-1/2"
- Overall Length — 2"

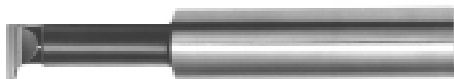

- Recessing
- Grooving

For cutting recessing grooves in bowed, self-locking and retaining rings

REGULAR LENGTH

HIGH SPEED STEEL					
Minimum Bore	Width of Recess	Max. Depth of Recess	Cutting Edge to CL	Tool Number	Price Each
3/8" SHANK					
1/4	.017/.018	.050	.14	RA17S-H	22.95
1/4	.022/.023	.050	.14	RA22S-H	22.95
1/4	.025/.026	.050	.14	RA25S-H	22.95
1/4	.028/.030	.050	.14	RA28S-H	22.95
1/4	.030/.031	.050	.14	RA30S-H	22.95
1/4	.040/.042	.050	.14	RA40S-H	22.95
1/2" SHANK					
13/32	.033/.034	.100	.25	RB33S-H	24.50
13/32	.038/.039	.100	.25	RB38S-H	24.50
13/32	.039/.041	.100	.25	RB39S-H	24.50
13/32	.046/.048	.100	.25	RB46S-H	24.50
13/32	.055/.057	.100	.25	RB55S-H	24.50

CARBIDE TIPPED					
Minimum Bore	Width of Recess	Max. Depth of Recess	Cutting Edge to CL	Tool Number	Price Each
3/8" SHANK					
1/4	.017/.018	.050	.14	RA17S-C	34.56
1/4	.022/.023	.050	.14	RA22S-C	34.56
1/4	.025/.026	.050	.14	RA25S-C	34.56
1/4	.028/.030	.050	.14	RA28S-C	34.56
1/4	.030/.031	.050	.14	RA30S-C	34.56
1/4	.040/.042	.050	.14	RA40S-C	34.56
1/2" SHANK					
13/32	.033/.034	.100	.25	RB33S-C	36.99
13/32	.038/.039	.100	.25	RB38S-C	36.99
13/32	.039/.041	.100	.25	RB39S-C	36.99
13/32	.046/.048	.100	.25	RB46S-C	36.99
13/32	.055/.057	.100	.25	RB55S-C	36.99

LONG LENGTH

Length of Shank — 2"

HIGH SPEED STEEL							
Min. Bore	Max. Reach	Width of Recess	Max. Depth of Recess	Cutting Edge to CL	Overall Length	Tool Number	Price Each
3/8" SHANK							
1/4	5/8	.017/.018	.050	.14	2-3/4	RA17L-H	24.30
1/4	5/8	.022/.023	.050	.14	2-3/4	RA22L-H	24.30
1/4	5/8	.025/.026	.050	.14	2-3/4	RA25L-H	24.30
1/4	5/8	.028/.030	.050	.14	2-3/4	RA28L-H	24.30
1/4	5/8	.030/.031	.050	.14	2-3/4	RA30L-H	24.30
1/4	5/8	.040/.042	.050	.14	2-3/4	RA40L-H	24.30
1/2" SHANK							
13/32	1-1/8	.033/.034	.100	.25	3-1/4	RB33L-H	25.95
13/32	1-1/8	.038/.039	.100	.25	3-1/4	RB38L-H	25.95
13/32	1-1/8	.039/.041	.100	.25	3-1/4	RB39L-H	25.95
13/32	1-1/8	.046/.048	.100	.25	3-1/4	RB46L-H	25.95
13/32	1-1/8	.055/.057	.100	.25	3-1/4	RB55L-H	25.95

CARBIDE TIPPED								
Min. Bore	Max. Reach	Width of Recess	Max. Depth of Recess	Cutting Edge to CL	Overall Length	Tool Number	Price Each	
3/8" SHANK								
1/4	5/8	.017/.018	.050	.14	2-3/4	RA17L-C	36.63	
1/4	5/8	.022/.023	.050	.14	2-3/4	RA22L-C	36.63	
1/4	5/8	.025/.026	.050	.14	2-3/4	RA25L-C	36.63	
1/4	5/8	.028/.030	.050	.14	2-3/4	RA28L-C	36.63	
1/4	5/8	.030/.031	.050	.14	2-3/4	RA30L-C	36.63	
1/4	5/8	.040/.042	.050	.14	2-3/4	RA40L-C	36.63	
1/2" SHANK								
13/32	1-1/8	.033/.034	.100	.25	3-1/4	RB33L-C	39.21	
13/32	1-1/8	.038/.039	.100	.25	3-1/4	RB38L-C	39.21	
13/32	1-1/8	.039/.041	.100	.25	3-1/4	RB39L-C	39.21	
13/32	1-1/8	.046/.048	.100	.25	3-1/4	RB46L-C	39.21	
13/32	1-1/8	.055/.057	.100	.25	3-1/4	RB55L-C	39.21	

HIGH SPEED STEEL SETS			
3/8" SHANK			
REGULAR LENGTH SET NO. RA375HS	LONG LENGTH SET NO. RA375HL		
6 Piece Set Includes 1 Piece of Each: Shown Above Supplied in Wood Block SET PRICE — \$137.00	6 Piece Set Includes 1 Piece of Each: Shown Above Supplied in Wood Block SET PRICE — \$145.00		
1/2" SHANK			
REGULAR LENGTH SET NO. RB500HS	LONG LENGTH SET NO. RB500HL		
5 Piece Set Includes 1 Piece of Each: Shown Above Supplied in Wood Block SET PRICE — \$122.00	5 Piece Set Includes 1 Piece of Each: Shown Above Supplied in Wood Block SET PRICE — \$129.00		

CARBIDE TIPPED SETS			
3/8" SHANK			
REGULAR LENGTH SET NO. RA375CS	LONG LENGTH SET NO. RA375CL		
6 Piece Set Includes 1 Piece of Each: Shown Above Supplied in Wood Block SET PRICE — \$207.00	6 Piece Set Includes 1 Piece of Each: Shown Above Supplied in Wood Block SET PRICE — \$219.00		
1/2" SHANK			
REGULAR LENGTH SET NO. RB500CS	LONG LENGTH SET NO. RB500CL		
5 Piece Set Includes 1 Piece of Each: Shown Above Supplied in Wood Block SET PRICE — \$184.00	5 Piece Set Includes 1 Piece of Each: Shown Above Supplied in Wood Block SET PRICE — \$196.00		



SOLID CARBIDE

• CARBIDE BURS

1/4" SHANK — DOUBLE CUT



(SA) Cylinder Shape

CYLINDRICAL			
Tool No.	Cutter Dia.	Length of Cut	Price Each
SA-11	1/8	1/2	10.90
SA-14	3/16	5/8	9.90
SA-1	1/4	5/8	9.70
SA-1L	1/4	1	20.20
SA-2	5/16	3/4	12.20
SA-3	3/8	3/4	13.20
SA-3L	3/8	1	25.80
SA-3XL	3/8	1-1/2	25.80
SA-4	7/16	1	19.80
SA-5	1/2	1	20.80
SA-6	5/8	1	26.30
SA-16	3/4	3/4	31.30
SA-7	3/4	1	39.30
SA-9	1	1	56.70



(SB) Cylinder Shape With End Cut

CYLINDRICAL WITH END CUT			
Tool No.	Cutter Dia.	Length of Cut	Price Each
SB-11	1/8	1/2	10.90
SB-14	3/16	5/8	11.30
SB-1	1/4	5/8	10.50
SB-1L	1/4	1	23.10
SB-2	5/16	3/4	13.50
SB-3	3/8	3/4	14.50
SB-3L	3/8	1	27.10
SB-4	7/16	1	21.40
SB-5	1/2	1	23.10
SB-6	5/8	1	28.80
SB-16	3/4	3/4	34.50
SB-7	3/4	1	42.00
SB-9	1	1	63.00



(SC) Cylinder Shape With Radius End

CYLINDRICAL BALL NOSE			
Tool No.	Cutter Dia.	Length of Cut	Price Each
SC-11	1/8	1/2	10.90
SC-12	1/8	5/8	11.30
SC-14	3/16	5/8	11.30
SC-1	1/4	5/8	11.10
SC-1L	1/4	1	24.10
SC-2	5/16	3/4	14.50
SC-3	3/8	3/4	14.70
SC-3L	3/8	1	27.30
SC-4	7/16	1	21.40
SC-5	1/2	1	23.10
SC-6	5/8	1	29.40
SC-7	3/4	1	42.00
SC-9	1	1	73.50



(SD) Ball Shape

BALL SHAPE			
Tool No.	Cutter Dia.	Length of Cut	Price Each
SD-11	1/8	1/8	11.10
SD-14	3/16	3/16	11.10
SD-1	1/4	1/4	10.70
SD-2	5/16	5/16	11.60
SD-3	3/8	3/8	13.10
SD-4	7/16	7/16	16.30
SD-5	1/2	1/2	16.80
SD-6	5/8	5/8	21.00
SD-7	3/4	3/4	28.60
SD-9	1	1	47.00



(SE) Oval Shape

OVAL SHAPE			
Tool No.	Cutter Dia.	Length of Cut	Price Each
SE-11	3/16	5/16	13.20
SE-1	1/4	3/8	13.20
SE-3	3/8	5/8	16.30
SE-5	1/2	7/8	23.10
SE-6	5/8	1	32.70
SE-7	3/4	1	42.00



(SF) Tree Shape With Radius End

ROUND TREE SHAPE			
Tool No.	Cutter Dia.	Length of Cut	Price Each
SF-11	1/8	1/2	12.00
SF-1	1/4	5/8	12.00
SF-3	3/8	3/4	15.10
SF-4	7/16	1	19.70
SF-13	1/2	3/4	21.20
SF-5	1/2	1	21.40
SF-6	5/8	1	30.70
SF-7	3/4	1	40.50
SF-14	3/4	1-1/4	42.20
SF-15	3/4	1-1/2	58.80



(SG) Tree Shape With Pointed End

POINTED TREE SHAPE			
Tool No.	Cutter Dia.	Length of Cut	Price Each
SG-1	1/4	5/8	12.00
SG-2	5/16	3/4	16.20
SG-3	3/8	3/4	15.10
SG-13	1/2	3/4	21.20
SG-5	1/2	1	21.40
SG-6	5/8	1	30.70
SG-7	3/4	1	40.50
SG-15	3/4	1	62.37



(SH) Flame Shape

FLAME SHAPE			
Tool No.	Cutter Dia.	Length of Cut	Price Each
SH-1	1/4	1/2	13.20
SH-2	5/16	3/4	14.70
SH-5	1/2	1-1/4	30.20
SH-6	5/8	1-7/16	43.50
SH-7	3/4	1-5/8	63.00



(SJ) 60° Cone Shape

60° INCLUDED ANGLE			
Tool No.	Cutter Dia.	Length of Cut	Price Each
SJ-1	1/4	3/16	11.00
SJ-2	5/16	1/4	12.00
SJ-3	3/8	1/4	13.40
SJ-5	1/2	7/16	16.60
SJ-6	5/8	1/2	21.80
SJ-7	3/4	5/8	29.30
SJ-9	1	3/4	46.20



• CARBIDE BURS

1/4" SHANK — DOUBLE CUT



(SK) 90° Cone Shape

90° INCLUDED ANGLE			
Tool No.	Cutter Dia.	Length of Cut	Price Each
SK-1	1/4	1/8	11.00
SK-2	5/16	3/16	12.00
SK-3	3/8	3/16	13.40
SK-5	1/2	1/4	16.60
SK-6	5/8	5/16	21.80
SK-7	3/4	3/8	29.30
SK-9	1	1/2	46.20



(SL) Taper With Radius End

14° INCLUDED ANGLE			
Tool No.	Cutter Dia.	Length of Cut	Price Each
SL-1	1/4	5/8	12.10
SL-2	5/16	7/8	15.30
SL-3	3/8	1-1/16	18.30
SL-4	1/2	1-1/8	23.30
SL-5	5/8	1-3/16	40.90
SL-6	5/8	1-5/16	40.90
SL-7	3/4	1-1/2	58.80



(SM) Cone Shape

CONE SHAPE			
Tool No.	Cutter Dia.	Length of Cut	Price Each
SM-1	1/4	1/2	11.70
SM-2	1/4	3/4	12.60
SM-3	1/4	1	13.40
SM-4	3/8	5/8	18.00
SM-5	1/2	7/8	23.10
SM-6	5/8	1	35.90



(SN) Inverted Cone Shape

INVERTED CONE			
Tool No.	Cutter Dia.	Length of Cut	Price Each
SN-1	1/4	5/16	10.80
SN-2	3/8	3/8	20.60
SN-4	1/2	1/2	21.40
SN-6	5/8	3/4	30.70
SN-7	3/4	5/8	36.10

BUR DISPENSER

Dimensions:
Measures 14-5/8" W x 7-3/8" D x 7-3/4" H
Weight: 10-1/2 lbs.



Holds these sizes:

- | | | |
|------|------|------|
| SA-1 | SD-5 | SG-3 |
| SA-3 | SE-1 | SG-4 |
| SA-5 | SE-3 | SL-1 |
| SB-1 | SE-5 | SL-3 |
| SB-3 | SF-1 | SL-4 |
| SB-5 | SF-3 | SM-2 |
| SD-1 | SF-5 | SM-3 |
| SD-3 | SG-1 | SM-5 |

PART NO. CZD132

PRICE EACH - \$78.00

Does not include burs

• MINIATURE CARBIDE BURS

DOUBLE CUT

1/16" THRU 1/8" DIAMETER HEAD
1-1/2" OVERALL LENGTH
1/8" SHANK



Tool No.	Cutter Dia.	Length of Cut	Price Each
SA-41	1/16	1/4	5.20
SA-42	3/32	7/16	5.20
SA-43	1/8	9/16	5.20
SC-41	3/32	7/16	5.20
SC-42	1/8	9/16	5.20
SD-41	3/32	3/32	5.20
SD-42	1/8	1/8	5.20
SE-41	1/8	7/32	5.20
SF-41	1/8	1/4	5.20
SF-42	1/8	1/2	5.20
SG-41	1/8	1/4	5.20
SG-42	1/8	5/16	5.20

Tool No.	Cutter Dia.	Length of Cut	Price Each
SG-43	1/8	3/8	5.20
SG-44	1/8	1/2	5.20
SH-41	1/8	1/4	5.20
SJ-42	1/8	3/32	5.20
SK-42	1/8	1/16	5.20
SL-41	1/8	3/8	5.20
SL-42	1/8	1/2	5.20
SM-41	1/8	11/32	5.20
SM-42	1/8	7/16	5.20
SM-43	1/8	5/8	5.20
SN-42	1/8	3/16	5.20

Tool No.	Cutter Dia.	Length of Cut	Price Each
SA-51	1/4	1/2	8.90
SB-51	1/4	3/16	8.90
SC-51	1/4	1/2	8.90
SD-51	1/4	7/32	8.90
SE-51	1/4	3/8	8.90
SF-51	1/4	1/2	8.90
SG-51	1/4	1/2	8.90
SM-51	1/4	1/2	8.90
SN-51	1/4	1/4	8.90



SOLID CARBIDE

• EXTRA LONG CARBIDE BURS

1/4" SHANK, 6" OVERALL — DOUBLE CUT

CYLINDRICAL SHAPE			
Tool No.	Cutter Dia.	Length of Cut	Price Each
SA-1L6	1/4	1/2	20.20
SA-3L6	3/8	3/4	25.80
SA-5L6	1/2	1	33.40

CYLINDRICAL BALL NOSE			
Tool No.	Cutter Dia.	Length of Cut	Price Each
SC-1L6	1/4	1/2	24.10
SC-3L6	3/8	3/4	27.30
SC-5L6	1/2	1	35.70

BALL SHAPE			
Tool No.	Cutter Dia.	Length of Cut	Price Each
SD-1L6	1/4	7/32	23.30
SD-3L6	3/8	5/16	25.40
SD-5L6	1/2	7/16	29.40

OVAL SHAPE			
Tool No.	Cutter Dia.	Length of Cut	Price Each
SE-1L6	1/4	3/8	25.70
SE-3L6	3/8	5/8	28.90
SE-5L6	1/2	7/8	35.70

ROUND TREE SHAPE			
Tool No.	Cutter Dia.	Length of Cut	Price Each
SF-1L6	1/4	1/2	24.60
SF-3L6	3/8	3/4	27.70
SF-5L6	1/2	1	34.00

POINTED TREE SHAPE			
Tool No.	Cutter Dia.	Length of Cut	Price Each
SG-1L6	1/4	1/2	24.60
SG-3L6	3/8	3/4	27.70
SG-5L6	1/2	1	34.00

FLAME SHAPE			
Tool No.	Cutter Dia.	Length of Cut	Price Each
SH-2L6	5/16	3/4	27.30
SH-5L6	1/2	1-1/4	43.20

14° INCLUDED ANGLE			
Tool No.	Cutter Dia.	Length of Cut	Price Each
SL-1L6	1/4	5/8	24.70
SL-3L6	3/8	1-1/16	30.90
SL-4L6	1/2	1-1/8	35.90

SOLID CARBIDE

• CARBIDE BURS FOR ALUMINUM

1/4" SHANK

OVAL SHAPE			
Tool No.	Cutter Dia.	Length of Cut	Price Each
SE-3NF	3/8	5/8	20.90
SE-5NF	1/2	7/8	29.70
SE-6NF	5/8	1	42.10
SE-7NF	3/4	1	54.00

ROUND TREE SHAPE			
Tool No.	Cutter Dia.	Length of Cut	Price Each
SF-1NF	1/4	3/4	15.40
SF-3NF	3/8	3/4	19.50
SF-5NF	1/2	1	27.60
SF-6NF	5/8	1	39.40
SF-14NF	3/4	1-1/4	54.30

14° INCLUDED ANGLE			
Tool No.	Cutter Dia.	Length of Cut	Price Each
SL-3NF	3/8	1-1/16	23.50
SL-4NF	1/2	1-1/8	30.00
SL-5NF	5/8	1-3/16	52.70
SL-6NF	5/8	1-5/16	52.70
SL-7NF	3/4	1-1/2	75.60

CYLINDRICAL			
Tool No.	Cutter Dia.	Length of Cut	Price Each
SA-1NF	1/4	3/4	12.50
SA-3NF	3/8	3/4	17.00
SA-5NF	1/2	1	26.70
SA-6NF	5/8	1	33.50
SA-7NF	3/4	1	50.50

CYLINDRICAL BALL NOSE			
Tool No.	Cutter Dia.	Length of Cut	Price Each
SC-1NF	1/4	3/4	14.50
SC-3NF	3/8	3/4	18.90
SC-5NF	1/2	1	29.70
SC-6NF	5/8	1	37.80
SC-7NF	3/4	1	54.00

BALL SHAPE			
Tool No.	Cutter Dia.	Length of Cut	Price Each
SD-1NF	1/4	7/32	14.20
SD-3NF	3/8	5/16	16.50
SD-5NF	1/2	7/16	21.60
SD-6NF	5/8	9/16	27.00
SD-7NF	3/4	11/16	36.70



SETS

CARBIDE BUR BOX SETS — DOUBLE CUT			
Set Description	Pieces Per Set	Set No.	Price Each
• SA1, SC1, SD1, SE1, SF1, SG1, SH1, SJ1, SK1, SL1, SM1, SN1	12	CBS12	146.00
• SA51, SB51, SC51, SD51, SE51, SF51, SG51, SM51, SN51	9	CBS9	80.10
• SA1, SA3, SC1, SC3, SD1, SD3, SF1, SF3	8	CBS8	99.00

◆ UNIVERSAL DRILL CHUCKS

KEY TYPE



Capacity		Mount	Tool No.	Price Each
Inches	mm			
3/8	10	3/8-24	DCK375	11.53
3/8	10	1/2-20	DCK375A	11.53
1/2	13	1/2-20	DCK500	15.72
1/2	13	33JT	DCK500A	15.72
1/2	13	6JT	DCK500B	15.72
5/8	16	5/8-16	DCK625	24.18

Chucks are provided with a key

◆ CHUCK KEYS

LIST NO. CH100



Key No.	For Use On	Price Each	Key No.	For Use On	Price Each
K0	0 Series	2.90	K7	7 Series	2.35
K1	1 Series	1.95	K30	30, 31 Series, 8-1/2N	2.75
K2	2 Series	2.90	K32	32, 33 Series, 11N	2.95
K3	3, 6, 34 Series, 14N, 55B, 56B, 58B, 75A	3.30	KK	DC8, SM8, 74K, 22BA, 23B, 24BA, 26BA, 29A	1.90
K3C	633C, 633D	3.45	ST13	Small Master Chuck Keys	13.00
K4	36, 37 Series, 16N, 18N, 59B	6.80	ST12	Large Master Chuck Keys	14.20
K5	20N	13.00			

◆ PRECISION BALL BEARING KEYLESS DRILL CHUCKS

HEAVY DUTY

- Keyless Drill Chucks are designed for high accuracy applications on either conventional or CNC machines in drilling, boring & counter-boring operations.
- Tighten and release by hand.
- Chucks have self-tightening feature.



Capacity		Mount	Tool No.	Price Each
Inches	mm			
0-1/4	0.3-6	1JT	DCK1JT	53.58
1/64-3/8	0.5-10	2JT	DCK2JT	55.66
1/64-3/8	0.5-10	33JT	DCK33JT	55.67
1/32-1/2	1-13	2JT	DCK2JTA	66.18
1/32-1/2	1-13	33JT	DCK33JTA	66.18
1/32-1/2	1-13	6JT	DCK6JT	66.18
1/8-5/8	3-16	6JT	DCK6JTA	80.86
1/8-5/8	3-16	3JT	DCK3JT	80.86

◆ DRILL CHUCK ARBORS

MORSE TAPER TO JACOBS TAPER

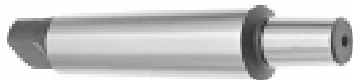

R-8 SHANKS FOR DRILL CHUCKS



STRAIGHT TO JACOBS TAPER

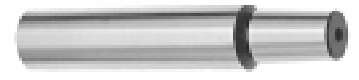

Morse Taper Shank	To Jacobs Taper	Tool No.	Price Each
1	1	DCM1J-1	5.95
1	2	DCM1J-2	5.95
1	3	DCM1J-3	6.50
1	33	DCM1J-33	6.50
1	6	DCM1J-6	6.50
2	1	DCM2J-1	5.95
2	2	DCM2J-2	5.95
2	3	DCM2J-3	5.95
2	33	DCM2J-33	5.95
2	4	DCM2J-4	7.75
2	6	DCM2J-6	7.75
3	1	DCM3J-1	7.95
3	2	DCM3J-2	7.95
3	3	DCM3J-3	7.95
3	33	DCM3J-33	7.95
3	4	DCM3J-4	8.75
3	5	DCM3J-5	8.75
3	6	DCM3J-6	8.75
4	2	DCM4J-2	12.50
4	3	DCM4J-3	12.50
4	33	DCM4J-33	12.50
4	4	DCM4J-4	12.50
4	5	DCM4J-5	12.50
4	6	DCM4J-6	12.50
5	3	DCM5J-3	22.75
5	4	DCM5J-4	22.75
5	5	DCM5J-5	22.75
5	6	DCM5J-6	22.75

Morse Taper Shank	To Jacobs Taper	Tool No.	Price Each
R8	1	R8J1	26.80
R8	2	R8J2	26.80
R8	3	R8J3	26.80
R8	33	R8J33	26.80
R8	4	R8J4	26.80
R8	6	R8J6	26.80

Straight Shank Size	To Jacobs Taper	Tool No.	Price Each
1/2	0	DCS12J-0	5.75
1/2	1	DCS12J-1	5.75
1/2	2	DCS12J-2	5.75
1/2	3	DCS12J-3	5.75
1/2	33	DCS12J-33	5.75
1/2	4	DCS12J-4	7.75
1/2	6	DCS12J-6	5.75
5/8	1	DCS58J-1	5.95
5/8	2	DCS58J-2	5.95
5/8	3	DCS58J-3	6.50
5/8	33	DCS58J-33	6.50
5/8	4	DCS58J-4	7.75
5/8	6	DCS58J-6	7.75
3/4	2	DCS34J-2	8.90
3/4	3	DCS34J-3	8.90
3/4	33	DCS34J-33	9.50
3/4	4	DCS34J-4	9.95
3/4	6	DCS34J-6	9.50
1	2	DCS1J-2	9.95
1	3	DCS1J-3	9.95
1	33	DCS1J-33	9.95
1	4	DCS1J-4	9.95
1	6	DCS1J-6	9.95
1-1/2	3	DCS112J-3	15.90
1-1/2	4	DCS112J-4	15.90

THREADED SHANK

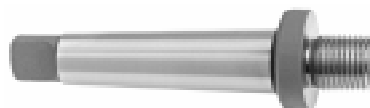

Morse Taper Shank	Shank Thread	Tool No.	Price Each
2	3/8 — 24	DCT38	32.98
2	1/2 — 20	DCT12	32.98
2	5/8 — 16	DCT58	32.98

PRECISION TOOLS

MICROMETERS

◆ OUTSIDE MICROMETERS

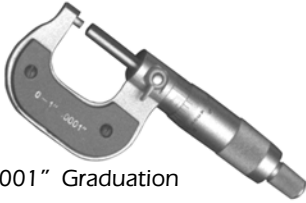

- .0001" Graduation
- Micro-Lapped carbide mirrored anvils
- Friction thimble
- Positive and wear-adjustable spindle lock
- 2" and over complete with standards
- Supplied in a fitted case
- Clear graduations on satin chrome finished sleeve

Range of Measure Inch/Metric	Tool No.	Price Each
0 - 1	PRM01	14.95
1 - 2	PRM12	19.95
2 - 3	PRM23	23.50
3 - 4	PRM34	26.75
4 - 5	PRM45	29.75
5 - 6	PRM56	34.75
0 - 25mm	PRMM25	14.95

◆ DIGITAL OUTSIDE MICROMETERS



- Carbide tip measuring faces
- Ratchet stop
- Digital counter indicates direct readings in .0001" graduation — tenths are read by means of a clearly marked Vernier Scale
- Sizes 2" and over complete with standards
- Supplied in a fitted case

Range of Measure Inch	Tool No.	Price Each
0 - 1	PRDM01	39.00
1 - 2	PRDM12	49.00
2 - 3	PRDM23	59.00
3 - 4	PRDM34	69.00

SETS



OUTSIDE MICROMETERS

Range of Measure Inch	Pieces Per Set	Tool No.	Price Each
0 - 3	3	PRMS03	49.75
0 - 6	6	PRMS06	125.00
6 - 12	6	PRMS612	229.00
0 - 12	12	PRMS012	289.00

DIGITAL OUTSIDE MICROMETERS

Range of Measure Inch	Pieces Per Set	Tool No.	Price Each
0 - 3	3	PRDMS03	129.00

◆ DEPTH MICROMETER



TOOL NO. PRDP06

- 0 - 6" Range
- 4" Length of base
- 6 Rods
- Satin chrome finish

PRICE EACH — \$65.00

◆ 0-1"/0-25mm ELECTRONIC DIGITAL MICROMETER



TOOL NO. PRME01

- Carbide tip measuring faces
- Spindle lock
- Instant inch/metric conversion
- Large, easy to read LCD readout
- Set in chrome spindle
- Automatic power off

PRICE EACH — \$89.00

◆ INSIDE MICROMETERS



- .001" Graduation
- Ratchet stop thimble
- Chrome plated
- Supplied in fitted case

Range of Measure Inch	Tool No.	Price Each
0.2 - 1.2	PRMN01	45.00
1 - 2	PRMN12	55.00

PRECISION TOOLS

◆ DIAL CALIPERS

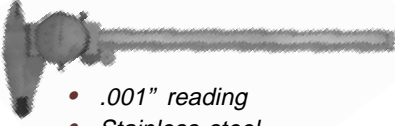

- .001" reading
- Stainless steel
- Covered rack
- .100 dial revolutions
- Supplied in a fitted case

Range of Measure Inch	Tool No.	Price Each
0 - 4	PRDC04	22.50
0 - 6	PRDC06	26.50
0 - 8	PRDC08	49.50
0 - 12	PRDC12	75.00

◆ VERNIER CALIPERS



- .001"/.02 mm Graduation
- Hardened stainless steel
- Satin chrome finish with clear black graduations
- Thumb lock style

Range of Measure	Tool No.	Price Each
0 - 6"/0-150 mm	PRV06	17.50
0 - 8"/0-200 mm	PRV08	24.50
0 - 12"/0-300 mm	PRV12	39.50

◆ ELECTRONIC DIGITAL CALIPERS

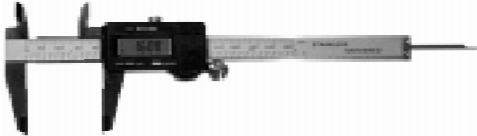

- Linear capacitive measuring system with LCD display.
- Thumb roller for easy movement.

ELECTRONIC DIGITAL CALIPER — 6"/150mm
TOOL NO. PRDE06
PRICE EACH — \$65.00

ELECTRONIC DIGITAL CALIPER — 8"/200mm
TOOL NO. PRDE08
PRICE EACH — \$89.00

◆ DIVIDERS AND CALIPERS



- Inside Caliper
- Outside Caliper
- Spring Divider

Size Inch	Inside Caliper Tool No.	Outside Caliper Tool No.	Spring Divider Tool No.	Price Each
4	PRCN4	PRCT4	PRCD4	2.95
6	PRCN6	PRCT6	PRCD6	4.25
8	PRCN8	PRCT8	PRCD8	5.50
10	PRCN10	PRCT10	PRCD10	7.50
12	PRCN12	PRCT12	PRCD12	10.95
18	PRCN18	PRCT18	PRCD18	22.95
24	PRCN24	PRCT24	PRCD24	42.50
36	PRCN36	PRCT36	PRCD36	62.00

◆ PROTRACTORS



- Stainless steel
- 0° - 180° graduation on head
- Adjustable 6" blade and lock nut

Description	Tool No.	Price Each
Square Head	PRPS	9.95
Round Head	PRPR	9.95

3 PIECE CALIPER SET

Set includes 1 each of the following:



- Inside Caliper
- Outside Caliper
- Spring Divider

Size Inch	Set No.	Price Each
4	PRCA4	8.75
6	PRCA6	12.50
8	PRCA8	15.95
10	PRCA10	21.75

◆ 60° CENTER GAGE

- Stainless steel
- Satin chrome finish
- Notches have clearance slots



TOOL NO. PRCG **PRICE EACH — \$4.95**

PRECISION TOOLS

GAGES



◆ ELECTRONIC HEIGHT GAGE

- Reading $.0005"/.01mm$
- Ground and hardened stainless steel frame
- Large clear LCD display

Range of Measure	Tool No.	Price Each
0-12"	PREHG12	239.00
0-18"	PREHG18	325.00



◆ VERNIER HEIGHT GAGE

- Stainless steel beam and measuring slide
- Carbide tipped scriber
- Fine adjustment slide
- Reading point $.001"/.02mm$

Range of Measure	Tool No.	Price Each
0-12"	PRHG12	69.00
0-18"	PRHG18	125.00
0-24"	PRHG24	145.00



◆ DIGITAL COUNTER TWIN BEAM DIGITAL HEIGHT GAGES

- Air proof digital counter featuring a 0 reset bottom
- Dial graduation $.001"$, counter graduation
- Fine adjusting wheel and lock

Range of Measure	Tool No.	Price Each
0-12"	PRGHD12	129.00
0-18"	PRGHD18	195.00
0-24"	PRGHD24	299.00

◆ DIAL BORE GAGES

- $.0005$ Graduation
- Interchangeable anvils and necessary accessories for close tolerance I.D. measurements



Range of Measure	Bore Depth	No. of Anvils	Tool No.	Price Each
0.4 - 0.7	2.4	9	PRBG47	96.00
0.7 - 1.5	4	8	PRBG715	96.00
1.4 - 2.4	6	6	PRBG1424	96.00
2 - 6	6	11	PRBG26	96.00
6.4 - 10	16	6	PRBG6410	96.00

◆ TELESCOPING GAGE SET

- Constant spring tension for uniform feel
- Rigid handle with self centering feature

SETNO. PRTGS06
6 Piece Set
6 Gages in a Fitted Case
Satin Chrome Finish
Range 5/16" to 6"
SET PRICE — \$24.75

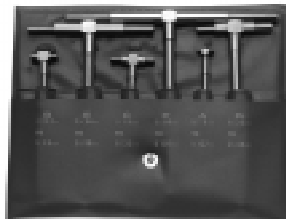

◆ RECTANGULAR GAGE BLOCK SET

SETNO. PRGBS81
GRADE B
81 Piece Set
Consists of following blocks:
9 Blocks from $.1001"$ to 1.000
49 Blocks from $.101$ to $.149$
19 Blocks from $.050$ to $.950$
4 Blocks from 1.000 to 4.00
Supplied in fitted wood case
SET PRICE — \$189.00

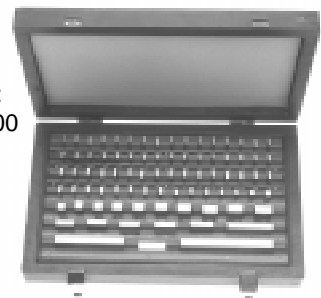

PRECISION TOOLS

◆ DIAL INDICATORS



- .001 Graduations with second hand reading every .010
- Lug back with 1/4" hole interchangeable point

Range of Measure	Tool No.	Price Each
1" Travel	PRD1	16.75
2" Travel	PRD2	48.00

◆ DIAL TEST INDICATORS



TOOL NO. PRDT30

- .030 Measuring range
- .0005 Graduation
- Includes 2 dovetail clamps - 3/8 and 5/32 dovetails on top and back for all-around positioning

PRICE EACH—\$54.95

◆ MAGNETIC BASE INDICATOR HOLDERS



- Easy on/off switch controls
- Strong permanent magnet
- Four ground surfaces to grip including V-slot for round surfaces
- Horizontal or vertical positioning

TOOL NO. PRMB1

Without fine adjustment
PRICE EACH—\$17.95

TOOL NO. PRMB2

With fine adjustment
PRICE EACH—\$19.95

◆ COMBINATION MAGNETIC BASE AND DIAL INDICATOR

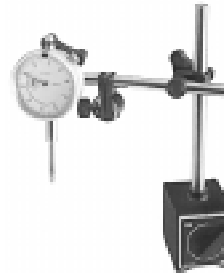

TOOL NO. PRMBD

- 1" Travel indicator
- Magnetic base with fine adjustment

PRICE EACH—\$34.00

◆ UNIVERSAL INDICATOR HOLDERS

TOOL NO. PRUH2

- Reach from 0-12" diameter
- For milling machine and jig borers
- For dial test indicators

PRICE EACH—\$22.50

TOOL NO. PRUH2DT

- With 1" dial indicator
- 1" Travel - .001 graduations

PRICE EACH—\$79.50



◆ CENTERING INDICATORS



- .0004 Graduation
- For centering a work piece on vertical or horizontal machines, external or internal diameters

TOOL NO. PRCOAX

Includes:

- 1 Restraining rod
- 1 Center point feeler
- 1 4" straight feeler
- 1 4" curved feeler
- 1 8" straight feeler
- 1 8" curved feeler
- 1 12" straight feeler
- 1 12" curved feeler

PRICE EACH—\$129.00



◆ MINI-MAGNETIC BASE INDICATOR HOLDER



TOOL NO. PRMB4

- Fine adjustment and two universal adjustments
- Ideal for very tight work areas
- Clamps all indicators with 1/8"-1" stem as well as dovetail style

PRICE EACH—\$9.95

◆ SUPER MAG UNIVERSAL MAGNETIC BASE



TOOL NO. PRSMB

- Zinc die cast housing
- Strong magnetic holding power

PRICE EACH—\$9.95

PRECISION TOOLS

◆ TOOLMAKER'S PARALLEL CLAMP

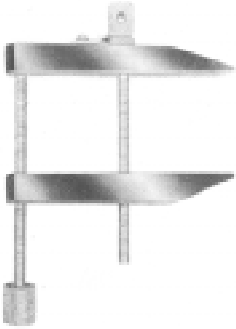

- Hardened jaws and screws with spring tension clips
- Conforms to federal standards

Jaw Opening	OAL	Tool No.	Price Each
1-1/4	2	PRTC114	5.10
1-3/4	2-1/2	PRTC134	5.57
2-1/4	3	PRTC214	6.98
2-3/4	4	PRTC234	9.02
3-1/2	5	PRTC312	14.95
4-1/2	6	PRTC412	19.12

◆ 3 PIECE MACHINIST SET

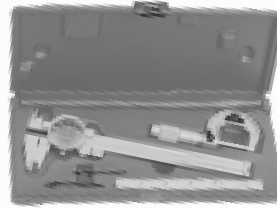

SET NO. PRMS3

Contains 1 Each:

0-1 Micrometer
.0001" Graduation, carbide tipped
6" Dial Caliper .100"

Dial revolution, stainless steel, satin chrome finish with covered rack 16" rigid rule, 4R Graduation
Supplied in fitted case

SET PRICE — \$43.50

◆ GRANITE SURFACE COMPARATOR STAND



TOOL NO. PRGS6

- With fine adjustment
- 6" Square granite base

PRICE EACH — \$45.00

◆ COMBINATION GRANITE SURFACE COMPARATOR STAND

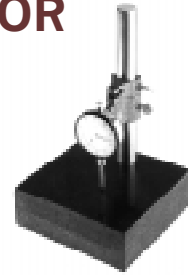

TOOL NO. PRGSD

- With 1" travel indicator

PRICE EACH — \$59.00

◆ EYE LOUPES



- Hand – Free Magnification
- Lenses made of ground and polished optical glass

Magnification Power	Focal Length	Tool No.	Price Each
2X	4.5"/114mm	PRMGL2	1.95
3X	3.5"/89mm	PRMGL3	2.50
4X	2.5"/63mm	PRMGL4	3.50
5X	2.0"/50mm	PRMGL5	3.95
10X	1.0"/25mm	PRMGL10	6.50

◆ MAGNIFYING READING GLASSES



- Light weight
- Edge to edge clarity
- Sturdy construction

Length Diameter	Focal Length	Power	Tool No.	Price Each
2"/50mm	6"/15cm	2.5X	PRMG2	8.95
2-1/2"/60mm	6"/15cm	2.5X	PRMG25	11.50
3"/75mm	8"/20cm	2.25X	PRMG3	14.75
4"/100mm	8"/20cm	2.25X	PRMG4	18.75

◆ FOLDING POCKET MAGNIFIER – TRIPLET



TOOL NO. PRMGP

- Combination of lenses produces different powers
- Magnification range of 4x, 7x, and 10x
- Focal length of 2.5", 1.5" and 1" or 6cm, 3.8cm and 2.5cm

PRICE EACH — \$8.75

◆ ILLUMINATED FLASHLIGHT MAGNIFIER



TOOL NO. PRMGF

- Works the same as a flashlight
- Magnification power 10x
- Uses 2 size C batteries (Not included)

PRICE EACH — \$26.95

PRECISION TOOLS

◆ UNIVERSAL BEVEL PROTRACTOR

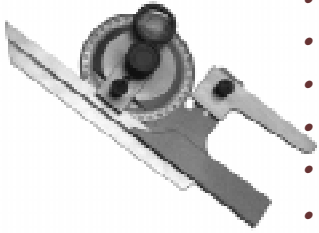

TOOL NO. PRUB12

- 16" and 12" blades
- Satin chrome finish
- Minimum reading 5 minutes
- 360° Scale in 1° increments
- Optical magnifier
- Blade and protractor have independent locking provisions to allow maximum control.

PRICE EACH — \$69.00

◆ HARDENED STEEL SQUARES



- Beams and blades are ground and lapped for parallelism
- Squares are true right angles, both inside and outside

Blade Length	Beam Length	Tool No.	Price Each
2	1-1/2	PRQ2	5.95
3	2-1/2	PRQ3	6.50
4	3	PRQ4	6.95
6	4	PRQ6	8.95
8	5	PRQ8	12.50
12	8	PRQ12	29.00

◆ COMBINATION SQUARE SET

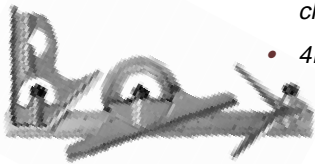

- Fully hardened with chrome finished blades
- 4R graduations

SET NO. PRCS4

4 Piece Set
12" Blade with Square Head,
Center Head and Protractor Head.

SET PRICE — \$59.00

◆ 1/8" THIN STYLE STEEL PARALLEL SET



- Matched pairs
- High grade alloy steel
- Hardened and ground
- Two holes in each parallel
- Accuracy $\pm .0002"$ parallelism in height
 $\pm .0001"$ to size and height

SET NO. PRTP10

Complete Set
10 Pairs in a Fitted Box

SET PRICE — \$99.00

◆ ADJUSTABLE PARALLEL SET



Parallels consist of 2 pieces which are ducktailed

SET NO. PRAP06

6 Piece Set
Range 3/8" to 2-1/4"
Supplied in fitted case

SET PRICE — \$49.00

◆ RATCHET MACHINE COUNTERS



TOOL NO. PRMC5

- 5 Digits with rotary reset knob
- 4 Flange holes for rigid mounting
- Lever furnished with spring and can be set in any position

PRICE EACH — \$6.50

◆ CARBIDE SCRIBER



TOOL NO. PRCS6

- With pocket clip and knurled grip

PRICE EACH — \$2.99

PRECISION TOOLS

◆ SPACE BLOCK SET

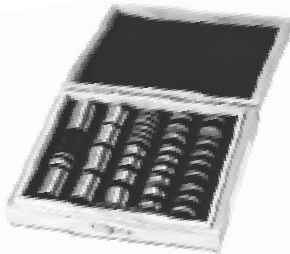

- Accuracy .0001
- 3/4" Diameter, 1/4-28 I.D. Thread
- Hardened and tapped
- 4 Connecting screws included, make any length desired

SET NO. PRSB36

36 Piece Set

.050, .060, .0625, .070, .080, .090, .100, .101, .102, .103, .104, .105, .106, .107, .108, .109, .110, .120, .125, .130, .140, .150, .160, .170, .180, .190, .200, .300, .400, .500, .600, .700, .800, .900, 1.000
(2 Pc.)

Supplied in wood case.

SET PRICE — \$59.95

◆ 1-2-3 AND 2-4-6 BLOCKS

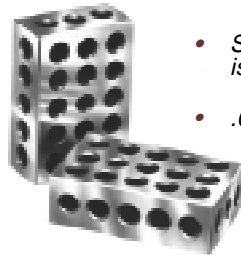

- Squareness of all sides is within .0001 of an inch
- .0001 - .0002 for parallelism

1-2-3 BLOCKS

SET NO. PRBS123

Contains 2 matched and hardened precision ground blocks

SET PRICE — \$22.50

2-4-6 BLOCKS

SET NO. PRBS246

Contains 2 matched and hardened precision ground blocks

SET PRICE — \$89.00

◆ PRECISION ANGLE BLOCK SET

Hardened Steel — Precision Ground



SET NO. PRABS10

10 Piece Set

Furnished in increments of:

1 Degree to 5 Degree

and 5 Degree to 30 Degree

Accurate to .0001 per inch.

Supplied in fitted wood case.

SET PRICE — \$69.00

◆ PRECISION FLEXIBLE RULES



Length	Width	Graduation	Tool No	Price Each
6	1/2	8ths, 16ths, 32nds, 64ths	SR4R	2.95
6	1/2	10ths, 64ths, 32nds, 100ths	SR5R	2.95
12	1/2	1/8ths, 16ths, 32nds, 64ths	SR124R	6.50
12	1/2	10ths, 64ths, 32nds, 100ths	SR125R	6.50
18	3/4	8ths, 16ths, 32nds, 64ths	SR184R	12.50
18	3/4	10ths, 64ths, 32nds, 100ths	SR185R	12.50
24	3/4	8ths, 16ths, 32nds, 64ths	SR244R	16.50
24	3/4	10ths, 64ths, 32nds, 100ths	SR245R	16.50

◆ PRECISION RIGID RULES



Length	Width	Graduation	Tool No	Price Each
6	1/2	8ths, 16ths, 32nds, 64ths	SRR4R	2.95
6	1/2	10ths, 64ths, 32nds, 100ths	SRR5R	2.95
12	1/2	1/8ths, 16ths, 32nds, 64ths	SRR124R	6.50
12	1/2	10ths, 64ths, 32nds, 100ths	SRR125R	6.50
18	3/4	8ths, 16ths, 32nds, 64ths	SRR184R	12.50
18	3/4	10ths, 64ths, 32nds, 100ths	SRR185R	12.50
24	3/4	8ths, 16ths, 32nds, 64ths	SRR244R	16.50
24	3/4	10ths, 64ths, 32nds, 100ths	SRR245R	16.50

◆ PLANER AND SHAPER GAUGE

TOOL NO. PRPSG

- Set shaper and planer tools fast and easy

- Range - 1/4" to 6-1/4"

- Base and slide are hardened and beveled to provide accurate alignment and parallelism



PRICE EACH — \$89.00

◆ CENTER PUNCHES ROUND AND SQUARE SHANKS



Hardened and tempered with ground points and knurled body for better grip.

Size at Top of Taper	Overall Length	Round Shank		Square Shank	
		Tool No.	Price Each	Tool No.	Price Each
1/16	3"	PHC1	1.95	PHCS1*	2.65
5/64	4	PHC2	2.15	PHCS2	2.65
3/32	4	PHC3	2.25	PHCS3	2.65
9/64	4	PHC4	2.35	PHCS4	2.80
5/32	4	PHC5	2.45	PHCS5	3.25

* 1/16 Square Shank overall length is 4".

ROUND SHANK SET NO. PHC15

5 Piece Set
Contains 1 Piece of Each:
1/16, 5/64, 3/32,
9/64 and 5/32
Supplied in Pouch
SET PRICE — \$9.95

SQUARE SHANK SET NO. PHCS15

5 Piece Set
Contains 1 Piece of Each:
1/16, 5/64, 3/32,
9/64 and 5/32
Supplied in Pouch
SET PRICE — \$12.75

◆ TRANSFER PUNCH SETS

OXIDE FINISH

- Made of heat-treated tempered tool steel
- Supplied in metal stand.



Set Number	Description	Pieces Per Set	Price Each
PH100	3/32 thru 1/2 by 64th and 17/32	28	19.95
PH101	#1 - 60	60	32.50
PH102	A - Z	26	29.00
PH104	1/2 thru 1" by 64th	33	98.00

◆ AUTOMATIC CENTER PUNCH

STEEL BODY



TOOL NO. PHA

- Hardened and ground punch
- Knurled body
- Spring loaded, no hammer required
- Adjustable tension cap

PRICE EACH — \$9.50

◆ DRIVE PIN PUNCHES

4" AND 8" OVERALL



- Hardened and tempered
- Centerless ground

Size of Tip	4" Overall		8" Overall	
	Tool No.	Price Each	Tool No.	Price Each
1/16	PHD1	1.80	—	—
3/32	PHD2	1.80	—	—
1/8	PHD3	1.80	PHL3	2.85
5/32	PHD4	1.80	—	—
3/16	PHD5	1.80	PHL5	2.85
7/32	PHD6	1.80	—	—
1/4	PHD7	1.80	PHL7	2.85
5/16	PHD8	1.80	PHL8	2.85
3/8	—	—	PHL9	2.85

Punch Diameter point is .005 undersize of nominal tip.

4" OVERALL SET NO. PHD18

8 Piece Set
Contains 1 Piece of Each:
1/16, 3/32, 1/8, 5/32, 3/16,
7/32, 1/4 and 5/16
Supplied in Pouch
SET PRICE — \$13.50

8" OVERALL SET NO. PHL15

5 Piece Set
Contains 1 Piece of Each:
1/8, 3/16, 1/4, 5/16 and 3/8
Supplied in Pouch
SET PRICE — \$13.50

◆ UNIVERSAL TRANSFER CENTER PUNCH AND ALIGNER

- All parts hardened steel
- For perfect center hole alignment
- Precision ground punch
- Knurled body

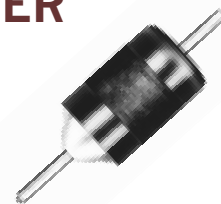

Accommodates itself automatically to accurately transfer center holes within range of punch.

Range of Measure	Tool No.	Price Each
3/16 to 5/8	PHUA1	12.95
3/16 to 1-3/16	PHUA2	16.95

◆ CENTER PUNCH WITH MAGNIFIER

TOOL NO. PHM

- Small powerful magnifier helps locate center

PRICE EACH — \$12.95





◆ 5C PRECISION ROUND COLLETS

SET NO. CKS-1

6 Piece Set
Contains 1 piece of each:
1/8, 1/4, 3/8, 1/2, 5/8, 3/4
Supplied in metal stand
SET PRICE \$76.50

Size	Tool No.	Price Each
1/16	CK116	12.80
5/64	CK564	12.80
3/32	CK332	12.80
7/64	CK764	12.80
1/8	CK18	12.80
9/64	CK964	12.80
5/32	CK532	12.80
11/64	CK1164	12.80
3/16	CK316	12.80
13/64	CK1364	12.80
7/32	CK732	12.80
15/64	CK1564	12.80
1/4	CK14	12.80
17/64	CK1764	12.80
9/32	CK932	12.80
19/64	CK1964	12.80
5/16	CK516	12.80
21/64	CK2164	12.80
11/32	CK1132	12.80
23/64	CK2364	12.80
3/8	CK38	12.80
25/64	CK2564	12.80
13/32	CK1332	12.80

SET NO. CKS-2

18 Piece Set
Contains 1 piece of each:
1/16 - 1-1/8 by 16ths
Supplied in metal stand
SET PRICE \$249.00

SET NO. CKS-3

30 Piece Set
Contains 1 piece of each:
1/16 - 13/16 by 32nds
and 7/8 - 1-1/8 by 16ths
Supplied in metal stand
SET PRICE \$398.00

Size	Tool No.	Price Each
27/64	CK2764	12.80
7/16	CK716	12.80
29/64	CK2964	12.80
15/32	CK1532	12.80
31/64	CK3164	12.80
1/2	CK12	12.80
33/64	CK3364	12.80
17/32	CK1732	12.80
35/64	CK3564	12.80
9/16	CK916	12.80
37/64	CK3764	12.80
19/32	CK1932	12.80
39/64	CK3964	12.80
5/8	CK58	12.80
41/64	CK4164	12.80
21/32	CK2132	12.80
43/64	CK4364	12.80
11/16	CK1116	12.80
45/64	CK4564	12.80
23/32	CK2332	12.80
47/64	CK4764	12.80
3/4	CK34	12.80
49/64	CK4964	12.80

Size	Tool No.	Price Each
25/32	CK2532	12.80
51/64	CK5164	12.80
13/16	CK1316	12.80
53/64	CK5364	12.80
27/32	CK2732	12.80
55/64	CK5564	12.80
7/8	CK78	12.80
57/64	CK5764	12.80
29/32	CK2932	12.80
59/64	CK5964	12.80
15/16	CK1516	12.80
61/64	CK6164	12.80
31/32	CK3132	12.80
63/64	CK6364	12.80
1	CK10	12.80
1-1/64	CK164-1	12.80
1-1/32	CK132-1	12.80
1-3/64	CK364-1	12.80
1-1/16	CK116-1	12.80
1-5/64	CK564-1	12.80
1-3/32	CK332-1	12.80
1-7/64	CK764-1	12.80
1-1/8	CK118-1	12.80

5C COLLET RACK

TOOL NO CZ5C

Holds 30 Collets
All Metal

PRICE EACH \$23.50

5C COLLET STOP	
Tool No.	Price Each
CKUK	14.85

ADJ. THREADED STOP FOR 5C COLLETS	
Tool No.	Price Each
CKAT	4.95

5C EMERGENCY COLLETS			
Collet Style	Type	Tool No	Price Each
5C	Steel	CKES	16.75
5C	Brass	CKEB	35.95

◆ R8 PRECISION ROUND COLLETS

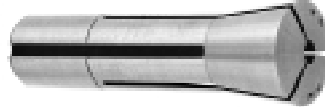

SET NO. R8CS-1

6 Piece Set
Contains 1 piece of each:
1/8, 1/4, 3/8, 1/2, 5/8, 3/4
Supplied in wood block
SET PRICE \$76.00

Size	Tool No.	Price Each
1/16	R8C116	12.80
3/32	R8C332	12.80
1/8	R8C18	12.80
5/32	R8C532	12.80
3/16	R8C316	12.80
7/32	R8C732	12.80
1/4	R8C14	12.80
9/32	R8C932	12.80
5/16	R8C516	12.80
11/32	R8C1132	12.80
3/8	R8C38	12.80
13/32	R8C1332	12.80
7/16	R8C716	12.80
15/32	R8C1532	12.80

SET NO. R8CS-2

14 Piece Set
Contains 1 piece of each:
1/16 thru 7/8 by 16ths
Supplied in metal stand
SET PRICE \$198.00

Size	Tool No.	Price Each
1/2	R8C12	12.80
17/32	R8C1732	12.80
9/16	R8C916	12.80
19/32	R8C1932	12.80
5/8	R8C58	12.80
21/32	R8C2132	12.80
11/16	R8C1116	12.80
23/32	R8C2332	12.80
3/4	R8C34	12.80
25/32	R8C2532	12.80
13/16	R8C1316	12.80
27/32	R8C2732	12.80
7/8	R8C78	12.80

SET NO. R8CS-3

27 Piece Set
Contains 1 piece of each:
1/16 thru 7/8 by 32nds
Supplied in 2 metal stands
SET PRICE \$384.00

R-8 COLLET RACK TOOL NO CZR8

Holds 16 Collets
All Metal
PRICE EACH \$23.50

◆ R8 METRIC COLLETS

Size m m	Tool No.	Price Each
2	R8CM2	14.90
3	R8CM3	14.90
4	R8CM4	14.90
5	R8CM5	14.90
6	R8CM6	14.90
7	R8CM7	14.90
8	R8CM8	14.90
9	R8CM9	14.90
10	R8CM10	14.90
11	R8CM11	14.90
12	R8CM12	14.90
13	R8CM13	14.90
14	R8CM14	14.90
15	R8CM15	14.90
16	R8CM16	14.90
17	R8CM17	14.90
18	R8CM18	14.90
19	R8CM19	14.90
20	R8CM20	14.90

R-8 EMERGENCY COLLETS

Steel Type

TOOL NO. R8CES

PRICE EACH \$26.95

SET NO R8CM

19 Piece Set

Contains 2mm - 20mm by 1mm

Supplied in stand

SET PRICE \$279.00

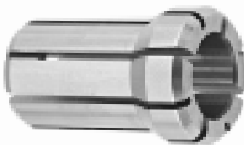

◆ DOUBLE ANGLE SPRING COLLETS 180°

Size	Tool No.	Price Each
1/8	DA-18	19.95
9/64	DA-964	19.95
5/32	DA-532	19.95
11/64	DA-1164	19.95
3/16	DA-316	19.95
13/64	DA-1364	19.95
7/32	DA-732	19.95
15/64	DA-1564	19.95
1/4	DA-14	15.50
17/64	DA-1764	15.50
9/32	DA-932	15.50
19/64	DA-1964	15.50
5/16	DA-516	15.50
21/64	DA-2164	15.50

Size	Tool No.	Price Each
11/32	DA-1132	15.50
23/64	DA-2364	15.50
3/8	DA-38	15.50
25/64	DA-2564	15.50
13/32	DA-1332	15.50
27/64	DA-2764	15.50
7/16	DA-716	15.50
29/64	DA-2964	15.50
15/32	DA-1532	15.50
31/64	DA-3164	15.50
1/2	DA-12	15.50
33/64	DA-3364	15.50
17/32	DA-1732	15.50
35/64	DA-3564	15.50

Size	Tool No.	Price Each
9/16	DA-916	15.50
37/64	DA-3764	15.50
19/32	DA-1932	15.50
39/64	DA-3964	15.50
5/8	DA-58	15.50
41/64	DA-4164	15.50
21/32	DA-2132	15.50
43/64	DA-4364	15.50
11/16	DA-1116	15.50
45/64	DA-4564	15.50
23/32	DA-2332	15.50
47/64	DA-4764	15.50
3/4	DA-34	15.50

SETS

SET NO. DA17S

17 Piece Set;

1/4 - 3/4 by 32nds

in wood box

SET PRICE — \$259.00

SET NO. DA33S

33 Piece Set;

1/4 - 3/4 by 64ths

in wood box

SET PRICE — \$510.00

◆ MILLING MACHINE ARBORS



- Style A Arbors are provided with end pilots 23/32" x 1-3/4"
- Style B Arbors are draw bar type furnished with appropriate spacers and running bushings.

Taper	Arbor Dia.	Length of Shoulder to Nut	Dia. of Running Bushing	Style	Arbor No. and Order No.	Price
30	7/8	10	1-5/8	A	M30-7/8-A10-2	189.00
30	1	10	1-5/8	A	M31-A10-2	205.00
30	1	2	—	B	M31-B2	145.00
30	1-1/4	10	1-5/8	A	M31-1/4-A10-2	229.00
30	1-1/4	10	1-7/8	A	M31-1/4-A10-3	229.00
40	7/8	10	—	A	M40-7/8-A10	205.00
40	7/8	14	1-7/8	B	M40-7/8-B14-3	225.00
40	7/8	16	1-7/8	A	M40-7/8-A16-3	299.00
40	7/8	16	1-7/8	B	M40-7/8-B16-3	275.00
40	1	3	—	B	M41-B3	137.00
40	1	8	—	A	M41-A8	209.00
40	1	10	—	A	M41-A10	219.00
40	1	12	—	A	M41-A12	259.00
40	1	14	1-7/8	B	M41-B14-3	315.00
40	1	16	1-7/8	A	M41-A16-3	315.00
40	1	20	1-7/8	B	M41-B20-3	365.00
40	1-1/4	3	—	B	M41-1/4-B3	145.00
40	1-1/4	8	—	A	M41-1/4-A8	229.00
40	1-1/4	10	—	A	M41-1/4-A10	255.00
40	1-1/4	12	—	A	M41-1/4-A12	275.00
40	1-1/4	14	1-7/8	B	M41-1/4-B14-3	319.00
40	1-1/4	16	1-7/8	A	M41-1/4-A16-3	319.00
40	1-1/4	20	1-7/8	B	M41-1/4-B20-3	389.00
40	1-1/2	20	2-1/8	B	M41-1/2-B20-4	450.00
50	7/8	10	—	A	M50-7/8-A10	257.00
50	7/8	18	2-1/8	A	M50-7/8-A18-4	379.00
50	1	3-1/2	—	B	M51-B3-1/2	168.00
50	1	8	—	A	M51-A8	214.00
50	1	12	—	A	M51-A12	286.00
50	1	15	2-1/8	B	M51-B15-4	305.00
50	1	18	2-1/8	A	M51-A18-4	378.00
50	1	18	2-1/8 (2)	B	M51-B18-4	342.00
50	1	24	2-1/8 (2)	B	M51-B24-4	399.00
50	1-1/4	3-1/2	—	B	M51-1/4-B3-1/2	162.00
50	1-1/4	8	—	A	M51-1/4-A8	233.00
50	1-1/4	12	—	A	M51-1/4-A12	328.00
50	1-1/4	15	2-1/8	B	M51-1/4-B15-4	347.00
50	1-1/4	18	2-1/8	A	M51-1/4-A18-4	399.00
50	1-1/4	18	2-1/8 (2)	B	M51-1/4-B18-4	365.00
50	1-1/4	24	2-1/8 (2)	B	M51-1/4-B24-4	424.00
50	1-1/4	30	2-1/8 (2)	B	M51-1/4-B30-5	533.00
50	1-1/2	3-1/2	—	B	M51-1/2-B3-1/2	193.00
50	1-1/2	18	2-1/8 (2)	B	M51-1/2-B18-4	606.00
50	1-1/2	24	2-3/4 (2)	B	M51-1/2-B24-5	470.00
50	1-1/2	30	2-3/4 (2)	B	M51-1/2-B30-5	573.00
50	1-1/2	36	2-3/4 (2)	B	M51-1/2-B36-5	646.00
50	2	24	2-3/4 (2)	B	M52-B24-5	573.00
50	2	30	2-3/4 (2)	B	M52-B30-5	649.00
50	2	36	2-3/4 (2)	B	M52-B36-5	720.00
50	2-1/2	36	3-3/8 (2)	B	M52-1/2-B36-6	1100.00

◆ STUB MILLING MACHINE ARBORS WITH WELDON SHANK

These arbors are made of alloy forged steel for a more durable service life. They are utilized for holding smaller cutters or saws and are designed to fit directly into end mill adapters. Three arbors spacers are included.

Shank Diameter	Arbor Diameter	Tool No.	Price Each
1/2	1/2	HSM1212	55.00
1/2	5/8	HSM5812	59.00
1/2	3/4	HSM3412	65.50
3/4	1/2	HSM1234	65.50
3/4	5/8	HSM5834	65.50
3/4	3/4	HSM3434	65.50
3/4	7/8	HSM7834	65.50
3/4	1	HSM10034	73.50
3/4	1-1/4	HSM11434	84.50

Price includes spacers and nut
1" length of shoulder to nut.

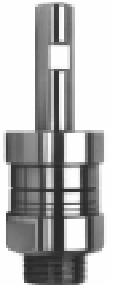

◆ ARBOR RUNNING BUSHINGS WITH KEYWAYS

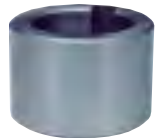

Size	I.D. of Hole	Overall Length	Tool No.	Price Each
1-5/8	7/8	2-5/8	ASB1587800	22.25
1-5/8	1	2-5/8	ASB158100	22.25
1-5/8	1-1/4	2-5/8	ASB158114	22.25
1-7/8	7/8	3-1/8	ASB1787800	29.00
1-7/8	1	3-1/8	ASB178100	29.00
1-7/8	1-1/4	3-1/8	ASB178114	29.00
2-1/8	7/8	3-3/4	ASB2187800	43.50
2-1/8	1	3-3/4	ASB218100	43.50
2-1/8	1-1/4	3-3/4	ASB218114	43.50
2-1/8	1-1/2	3-3/4	ASB218112	43.50
2-3/4	7/8	4-1/4	ASB2347800	55.00
2-3/4	1	4-1/4	ASB234100	55.00
2-3/4	1-1/4	4-1/4	ASB234114	55.00
2-3/4	1-1/2	4-1/4	ASB234112	55.00
2-3/4	2	4-1/4	ASB234200	55.00
3-3/8	2	4-1/4	ASB338200	75.00



◆ ARBOR SPACERS WITH KEYWAYS

- Hardened and ground on all surfaces
- Lapped for parallelism

Size	Tool No.	7/8 Bore Price Each	Tool No.	1" Bore Price Each	Tool No.	1-1/4 Bore Price Each	Tool No.	1-1/2 Bore Price Each	Tool No.	2" Bore Price Each	Tool No.	2-1/2 Bore Price Each
1/16	AS11678	3.95	AS116100	4.40	AS116114	5.17	AS116112	6.55	AS116200	8.00	AS116250	12.00
3/32	AS33278	3.95	AS332100	4.40	AS332114	5.17	AS332112	6.55	AS332200	8.00	AS332250	12.00
1/8	AS1878	3.95	AS18100	4.40	AS18114	5.17	AS18112	6.55	AS18200	8.00	AS18250	12.00
3/16	AS31678	3.95	AS316100	4.40	AS316114	5.17	AS316112	6.55	AS316200	8.00	AS316250	12.00
1/4	AS1478	4.20	AS14100	4.87	AS14114	5.50	AS14112	7.31	AS14200	8.75	AS14250	13.00
5/16	AS51678	4.55	AS516100	5.46	AS516114	6.05	AS516112	8.11	AS516200	10.00	AS516250	14.85
3/8	AS3878	4.55	AS38100	5.46	AS38114	6.05	AS38112	6.32	AS38200	10.70	AS38250	16.00
7/16	AS71678	5.55	AS716100	6.35	AS716114	6.85	AS716112	9.24	AS716200	12.25	AS716250	18.00
1/2	AS1278	5.85	AS12100	6.35	AS12114	7.64	AS12112	9.91	AS12200	13.00	AS12250	19.60
5/8	AS5878	6.35	AS58100	7.00	AS58114	8.32	AS58112	11.15	AS58200	15.20	AS58250	23.00
3/4	AS3478	7.00	AS34100	8.15	AS34114	9.24	AS34112	12.00	AS34200	16.80	AS34250	24.25
7/8	AS7878	7.80	AS78100	9.53	AS78114	9.91	AS78112	12.65	AS78200	18.40	AS78250	25.50
1	AS178	7.80	AS1100	9.53	AS1114	10.71	AS1112	14.30	AS1200	18.00	AS1250	27.70
1-1/4	AS11478	9.20	AS114100	11.47	AS114114	12.00	AS114112	16.00	AS114200	19.95	AS114250	30.00
1-1/2	AS11278	9.90	AS112100	13.36	AS112114	13.65	AS112112	17.65	AS112200	24.50	AS112250	36.75
2	AS278	12.90	AS2100	17.80	AS2114	16.00	AS2112	20.85	AS2200	27.20	AS2250	40.75
3	AS378	18.25	AS3100	20.41	AS3114	21.67	AS3112	26.30	AS3200	35.95	AS3250	53.75