

# CUTTING TOOLS 2024



COMPLETE METALWORKING SOLUTIONS

(800) 991-4225

[www.ahbinc.com](http://www.ahbinc.com)

ISO Certified

[customerservice@ahbinc.com](mailto:customerservice@ahbinc.com)

The DIA EDGE logo consists of the word 'DIA' in white, followed by a red and grey geometric icon, and the word 'EDGE' in white. The background of the bottom section of the cover features a collage of industrial images, including a red-tinted close-up of a metal part, a black and white image of a drill bit, and a black and white image of a lathe cutting a metal part.

DIA  EDGE

# HOW TO READ THE STANDARD OF EXTERNAL TURNING TOOLS

## ● How this section page is organized

- ① Organized according to turning insert shape. (Refer to the index on the next page.)

**TYPE OF TOOL HOLDER** indicates the first four letters of the order number, as well as cutting applications.

**TITLE OF PRODUCT BY INSERT TYPE**

**PRODUCT SECTION**

**FIGURE SHOWING THE TOOLING APPLICATION** uses illustrations and arrows to depict the available machining applications such as external turning, copying, facing, and chamfering together with cutting edge lead angles.

**GEOMETRY**

**CHIP BREAKER BY CUTTING APPLICATION**

**EXTERNAL TURNING TOOLS**

**VN INSERTS TOOL HOLDERS**

**MVLN** Facing Multiple Clamp Type M Holder Medium

Order Number	ANSI Number	Stock	Insert Number	Dimensions (inch)						Shim	Shim Pin	Clamp Bridge	Clamp Screw	#2
				H	B	LF	LH	HF	WF					
MVLNR-L164C	MVLNR/L164C	●	VNGM 43	1.000	1.000	5.000	1.500	1.000	1.750	IWSN433	NL46	CL30	XNS510	
MVLNR-L164D	MVLNR/L164D	●		1.000	1.000	6.000	1.500	1.000	1.750					
MVLNR-L204D	MVLNR/L204D	●		1.250	1.250	6.000	1.500	1.250	2.000					
MVLNR-244D	MVLNR244D	□		1.500	1.500	6.000	1.500	1.500	2.250					

● USA Stock □ Made to Order

\*1 (Opt.) See page M012 for different radius.  
\*2 Clamp Torque (lbf-in) : XNS510/70

**WN INSERTS TOOL HOLDERS**

**DWLN** External turning DOUBLE CLAMP Type M Holder

Order Number	ANSI Number	Stock	Insert Number	Dimensions (inch)						Shim	Shim Pin	Clamp Bridge	Clamp Screw	Wrench	#2	
				H	B	LF	LH	HF	WF							
DWLNRL-123	DWLNRL123B	●	33	750	750	4.500	1.000	750	1.000	LLSWN3	LLP23	DOCK21	DCS22	DOSS07	TKY115F	
DWLNRL-163	DWLNRL163D	●		1.000	1.000	6.000	1.000	1.000	1.250							
DWLNRL-124	DWLNRL124B	●		750	750	4.500	1.250	750	1.000							
DWLNRL-164	DWLNRL164D	●	43	1.000	1.000	6.000	1.250	1.000	1.250	LLSWN4	LLP14	DOCK15	DCS11	DOGG1	TKY20F	
DWLNRL-204	DWLNRL204D	●		1.250	1.250	6.000	1.250	1.250	1.500							

\*1 Please use shim no. LLSWN33 with .125inch thick insert. When using .125inch thick inserts, the shim must be ordered separately.  
\*2 Clamp Torque (lbf-in) : DC0620T\*31, DC0621T\*44

**MVLN** External turning Multiple Clamp Type M Holder

Order Number	ANSI Number	Stock	Insert Number	Dimensions (inch)						Shim	Shim Pin	Clamp Bridge	Clamp Screw	#2
				H	B	LF	LH	HF	WF					
MVLNR-L123C	MVLNR/L123C	●	33	750	750	4.500	1.000	750	1.000	IWSN322	NL34L	CL6	XNS36	
MVLNR-L132C	MVLNR/L132C	●		1.000	1.000	6.000	1.000	1.000	1.250					
MVLNR-L123B	MVLNR/L123B	●		750	750	4.500	1.000	750	1.000					
MVLNR-L133C	MVLNR/L133C	●	43	1.000	1.000	6.000	1.000	1.000	1.250	IWSN433	NL46	CL9	XNS59	
MVLNR-L124B	MVLNR/L124B	●		750	750	4.500	1.250	750	1.000					
MVLNR-L164D	MVLNR/L164D	●	54	1.000	1.000	6.000	1.250	1.000	1.250	IWSN533	NL58	CL9	XNS59	
MVLNR-L204D	MVLNR/L204D	●		1.250	1.250	6.000	1.250	1.250	1.500					
MVLNR-L854D	MVLNR/L854D	●	70	1.500	1.500	7.000	1.370	1.500	2.000	IWSN533	NL58	CL9	XNS59	
MVLNR-L165D	MVLNR/L165D	●		1.000	1.000	6.000	1.250	1.000	1.250					
MVLNR-L205D	MVLNR/L205D	●	1.250	1.250	6.000	1.370	1.250	1.500	1.500					
MVLNR-L245E	MVLNR/L245E	●	1.500	1.500	7.000	1.370	1.500	2.000						

● USA Stock □ Made to Order

\*1 (Opt.) See page M012 for different radius.  
\*2 Clamp Torque (lbf-in) : XNS36=30, XNS48=45, XNS59=70

**MWLN** External turning Multiple Clamp Type M Holder

Order Number	ANSI Number	Stock	Insert Number	Dimensions (inch)						Shim	Shim Pin	Clamp Bridge	Clamp Screw	#2
				H	B	LF	LH	HF	WF					
MWLNR-L123C	MWLNR/L123C	●	33	750	750	4.500	1.000	750	1.000	IWSN322	NL34L	CL6	XNS36	
MWLNR-L132C	MWLNR/L132C	●		1.000	1.000	6.000	1.000	1.000	1.250					
MWLNR-L123B	MWLNR/L123B	●		750	750	4.500	1.000	750	1.000					
MWLNR-L133C	MWLNR/L133C	●	43	1.000	1.000	6.000	1.000	1.000	1.250	IWSN433	NL46	CL9	XNS59	
MWLNR-L124B	MWLNR/L124B	●		750	750	4.500	1.250	750	1.000					
MWLNR-L164D	MWLNR/L164D	●	54	1.000	1.000	6.000	1.250	1.000	1.250	IWSN533	NL58	CL9	XNS59	
MWLNR-L204D	MWLNR/L204D	●		1.250	1.250	6.000	1.250	1.250	1.500					
MWLNR-L854D	MWLNR/L854D	●	70	1.500	1.500	7.000	1.370	1.500	2.000	IWSN533	NL58	CL9	XNS59	
MWLNR-L165D	MWLNR/L165D	●		1.000	1.000	6.000	1.250	1.000	1.250					
MWLNR-L205D	MWLNR/L205D	●	1.250	1.250	6.000	1.370	1.250	1.500	1.500					
MWLNR-L245E	MWLNR/L245E	●	1.500	1.500	7.000	1.370	1.500	2.000						

● USA Stock □ Made to Order

\*1 (Opt.) See page M012 for different radius.  
\*2 Clamp Torque (lbf-in) : XNS36=30, XNS48=45, XNS59=70

**LEGEND FOR STOCK STATUS MARK** is shown on the left hand page of each double-page spread.

**PRODUCT STANDARDS** indicates order numbers, stock status (per right/left hand), applicable inserts, dimensions, and spare parts.

**REFERENCE PAGE FOR APPLICABLE INSERTS** indicates reference pages giving details of inserts that are applicable to the product.

**PAGE REFERENCE** indicates reference pages, including the above, on the right hand page of each double-page spread.

● To Order : Please specify order number and hand of tool (right/left).

# TURNING TOOLS

## EXTERNAL TURNING TOOLS

CLASSIFICATION..... C002

IDENTIFICATION..... C004

METHOD OF HOLDING ..... C005

### STANDARD HOLDERS

CN  INSERTS TOOL HOLDERS..... C006

DN  INSERTS TOOL HOLDERS..... C010

RN  INSERTS TOOL HOLDERS..... C013

SN  INSERTS TOOL HOLDERS..... C014

TN  INSERTS TOOL HOLDERS..... C018

VN  INSERTS TOOL HOLDERS..... C024

WN  INSERTS TOOL HOLDERS..... C027

VB  INSERTS TOOL HOLDERS..... C028

CC  INSERTS TOOL HOLDERS..... C030

DC  INSERTS TOOL HOLDERS..... C031

RC  INSERTS TOOL HOLDERS..... C033

SC  INSERTS TOOL HOLDERS..... C034

TC  INSERTS TOOL HOLDERS..... C035

VC  INSERTS TOOL HOLDERS..... C036

WC  INSERTS TOOL HOLDERS..... C037

XC  INSERTS TOOL HOLDERS..... C038

RP  INSERTS TOOL HOLDERS..... C040

### ●AL HOLDER (FOR ALUMINUM TURNING)

DE  INSERTS TOOL HOLDERS ..... C041

TE  INSERTS TOOL HOLDERS ..... C042

VD  INSERTS TOOL HOLDERS ..... C043

\*Arranged by Alphabetical order









C006	<b>DCLN</b>	C010	<b>MDJN</b>	C032	<b>SDXC</b>
C008	<b>DCRN</b>	C011	<b>MDPN</b>	C033	<b>SRDC</b>
C010	<b>DDJN</b>	C013	<b>MRGN</b>	C040	<b>SRDP</b>
C011	<b>DDPN</b>	C016	<b>MSDN</b>	C033	<b>SRGC</b>
C012	<b>DDQN</b>	C017	<b>MSKN</b>	C034	<b>SSBC</b>
C013	<b>DRGN</b>	C014	<b>MSRN</b>	C034	<b>SSSC</b>
C016	<b>DSDN</b>	C015	<b>MSSN</b>	C035	<b>STFC</b>
C017	<b>DSKN</b>	C020	<b>MTAN</b>	C042	<b>STFE</b>
C014	<b>DSRN</b>	C021	<b>MTCN</b>	C035	<b>STGC</b>
C015	<b>DSSN</b>	C021	<b>MTEN</b>	C042	<b>STGE</b>
C022	<b>DTCN</b>	C023	<b>MTFN</b>	C029	<b>SVHB</b>
C022	<b>DTFN</b>	C019	<b>MTGN</b>	C028	<b>SVJB</b>
C018	<b>DTGN</b>	C018	<b>MTJN</b>	C036	<b>SVJC</b>
C024	<b>DVJN</b>	C020	<b>MTRN</b>	C043	<b>SVJD</b>
C025	<b>DVPN</b>	C024	<b>MVJN</b>	C036	<b>SVPC</b>
C025	<b>DVVN</b>	C026	<b>MVLN</b>	C043	<b>SVPD</b>
C027	<b>DWLN</b>	C027	<b>MWLN</b>	C028	<b>SVVB</b>
C009	<b>MCFN</b>	C030	<b>SCLC</b>	C037	<b>SWLC</b>
C008	<b>MCGN</b>	C031	<b>SDJC</b>	C038	<b>SXZC</b>
C007	<b>MCLN</b>	C041	<b>SDJE</b>		
C009	<b>MCRN</b>	C031	<b>SDNC</b>		

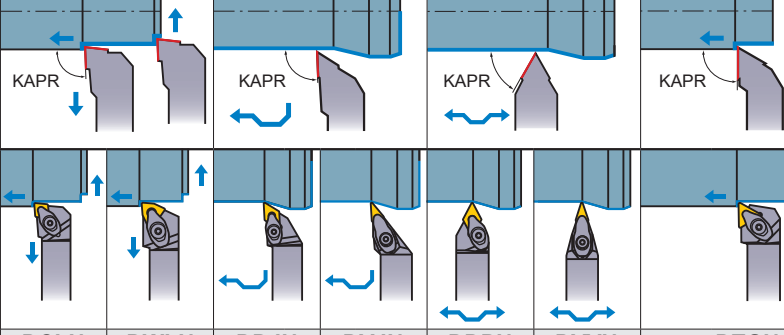

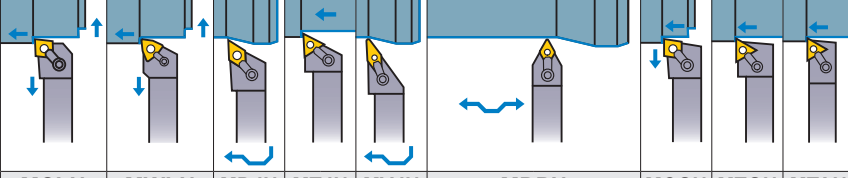
C001

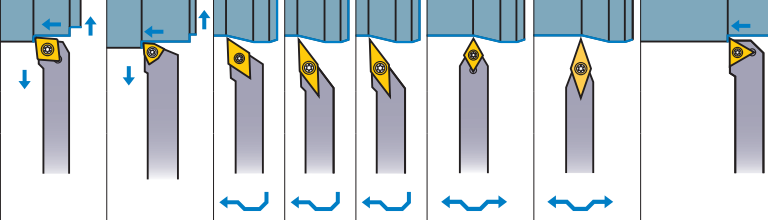
# CLASSIFICATION

EXTERNAL TURNING TOOLS

Tool Holder	Features	External Turning Facing	External Turning Copying				External Turning			
		KAPR= 95°	KAPR= 93°	KAPR= 62.5° 72.5°		KAPR= 90° – 91°				
 <p><b>DOUBLE CLAMP Holder</b></p> <ul style="list-style-type: none"> <li>● Double clamp type.</li> <li>● Holds inserts securely.</li> <li>● Excellent cutting edge tolerance.</li> <li>● Economical negative insert.</li> <li>● Recommended with CBN grade insert</li> </ul>		<p><b>DCLN</b> ↻ C006</p>	<p><b>DWLN</b> ↻ C027</p>	<p><b>DDJN</b> ↻ C010</p>	<p><b>DVJN</b> ↻ C024</p>	<p><b>DDPN</b> ↻ C011</p>	<p><b>DVVN</b> ↻ C025</p>	<p><b>DTGN</b> ↻ C018</p>		
 <p><b>M Holder</b></p> <ul style="list-style-type: none"> <li>● Negative rake clamp and locking pin tool holders.</li> <li>● Insert is securely held by a shim pin and clamp bridge.</li> <li>● Index operation is easy to perform.</li> <li>● (Opt.) Single clamp available as clamp on or pin lock holder.</li> </ul>		<p><b>MCLN</b> ↻ C007</p>	<p><b>MWLN</b> ↻ C027</p>	<p><b>MDJN</b> ↻ C010</p>	<p><b>MTJN</b> ↻ C018</p>	<p><b>MVJN</b> ↻ C024</p>	<p><b>MDPN</b> ↻ C011</p>	<p><b>MCGN</b> ↻ C008</p>	<p><b>MTGN</b> ↻ C019</p>	<p><b>MTAN</b> ↻ C020</p>
 <p><b>SP Holder</b></p> <ul style="list-style-type: none"> <li>● Small shank tool holder system using a 5°, 7° and 11° positive inserts retained by screw-on system.</li> </ul>		<p><b>SCLC</b> ↻ C030</p>	<p><b>SWLC</b> ↻ C037</p>	<p><b>SDJC</b> ↻ C031</p>	<p><b>SVJC</b> ↻ C036</p>	<p><b>SVJB</b> ↻ C028</p>	<p><b>SDNC</b> ↻ C031</p>	<p><b>SVVB</b> ↻ C028</p>	<p><b>STGC</b> ↻ C035</p>	
 <p><b>PROFILE Holder</b></p> <ul style="list-style-type: none"> <li>● 25° rhombic insert for profiling and face relief.</li> <li>● Machine 300° of a sphere.</li> <li>● Machine face relief to 60° angle.</li> <li>● The cycle time can be reduced due to only one holder.</li> </ul>										
 <p><b>AL Holder</b></p> <ul style="list-style-type: none"> <li>● Shank size .625 square thru 1.000 square with screw-on method.</li> <li>● Suitable for finishing aluminum or non-ferrous metals and for chatter control on small diameters.</li> </ul>				<p><b>SDJE</b> ↻ C041</p>	<p><b>SVJD</b> ↻ C043</p>			<p><b>STGE</b> ↻ C042</p>		







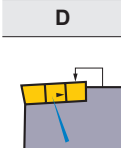

External Turning	External Turning, Chamfering		External Turning, Facing, Chamfering	Facing			Facing Copying	External Turning, Copying	Selection Standard					
KAPR= 75°	KAPR= 60°	KAPR= 45°	KAPR= 45°	KAPR= 75°	KAPR= 91°		KAPR= 107.5° 117.5°	Special Design	Economical	Low Cutting Resistance (Sharpness)	Clamp Rigidity	Operation Efficiency	Specialized	
<b>DCRN</b> ⊕ C008	<b>DSRN</b> ⊕ C014		<b>DSDN</b> ⊕ C016	<b>DSSN</b> ⊕ C015	<b>DSKN</b> ⊕ C017	<b>DTCN</b> ⊕ C022	<b>DTFN</b> ⊕ C022	<b>DVPN</b> ⊕ C025	<b>DDQN</b> ⊕ C012	<b>DRGN</b> ⊕ C013	⊙	⊙	⊙	
												⊙	○	⊙
<b>MCRN</b> ⊕ C009	<b>MSRN</b> ⊕ C014	<b>MTRN</b> ⊕ C020	<b>MTEN</b> ⊕ C021	<b>MSDN</b> ⊕ C016	<b>MSSN</b> ⊕ C015	<b>MSKN</b> ⊕ C017	<b>MCFN</b> ⊕ C009	<b>MTCN</b> ⊕ C021	<b>MTFN</b> ⊕ C023	<b>MVLN</b> ⊕ C026	<b>MRGN</b> ⊕ C013	⊙	○	⊙
													○	
<b>SSBC</b> ⊕ C034				<b>SSSC</b> ⊕ C034			<b>STFC</b> ⊕ C035	<b>SVHB</b> ⊕ C029	<b>SVPC</b> ⊕ C036	<b>SRDC</b> ⊕ C033	<b>SRDP</b> ⊕ C040		○	⊙
													○	⊙
								<b>SXZC</b> ⊕ C038					○	⊙
													⊙	⊙
							<b>STFE</b> ⊕ C042	<b>SVPD</b> ⊕ C043					⊙	⊙

Note 1) ⊙ : 1st recommendation. ○ : 2nd recommendation.



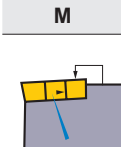
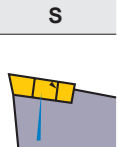



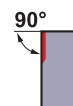
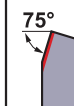
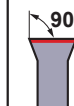
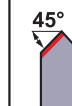
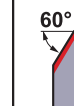

# IDENTIFICATION

DOUBLE CLAMP Holder, M Holder, SP Holder, PROFILE Holder, AL Holder

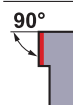
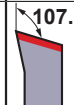
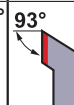
EXTERNAL TURNING TOOLS

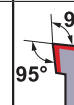
 Double Clamp Type		 80° Rhombic		 55° Rhombic		 Round		 Square			
 Multiple Clamp Type		 Screw Clamp Type		 Triangular		 35° Rhombic		 Trigon		Special Design	

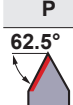
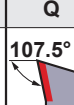
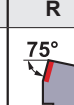
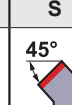
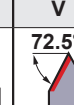

③ Tool Style					
A	B	C	D	E	F
					
G	H	J	K	L	N
					
P	Q	R	S	V	X
					

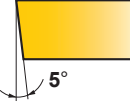
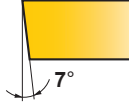
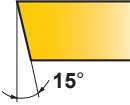
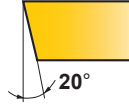
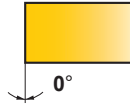
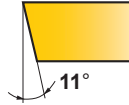

① Method of Holding: M, C, L, N, R - ⑥ Tool Size: 16, 5, D



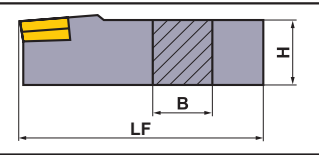

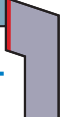

④ Insert Relief Angle	
B	C
	
D	E
	
N	P
	

⑥ Tool Size [Height (H) and Width (B)] (inch)								
	06	08	10	12	16	20	24	85
H	.375	.500	.625	.750	1.000	1.250	1.500	1.250
B	.375	.500	.625	.750	1.000	1.250	1.500	1.000



In case of B=H, the number will represent the number of sixteenths of B and H.  
 In case of B≠H, the first digit represents the number of eighths of B, and the second digit represents the number of quarters of H.

⑤ Hand of Tool		
R	L	N
		

⑦ Insert Size										
Inscribed Circle of Insert (inch)	.156	.187	.219	.250	.313	.375	.500	.625	.750	1.000
	1.2	1.5	1.8	2	2.5	3	4	5	6	
 						3	4	5	6	8
	1.2	1.5		2		3	4	5		
80° 	1.2	1.5		2	2.5	3	4	5	6	
55° 				2		3	4	5		
35° 		1.5		2		3	4			

⑧ Tool Length (LF) (inch)					
A	B	C	D	E	X
4.000	4.500	5.000	6.000	7.000	< 4.000

# METHOD OF HOLDING

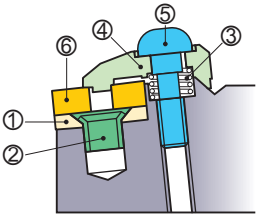
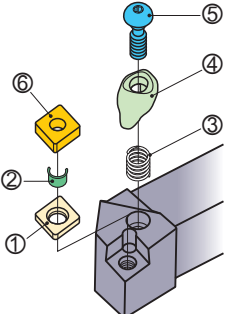
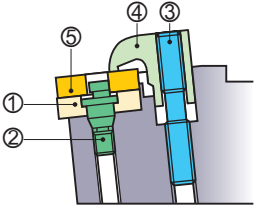
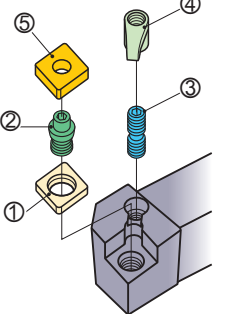
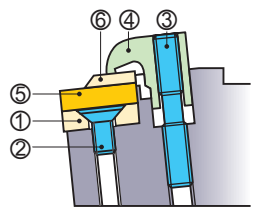
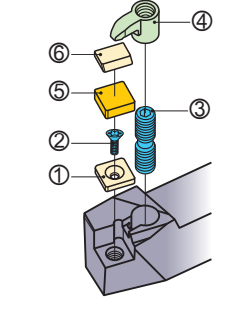
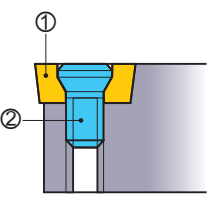
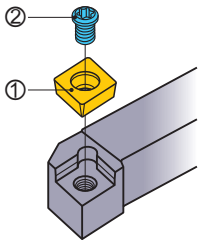
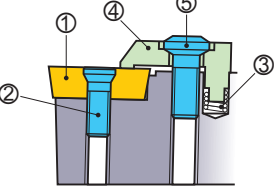
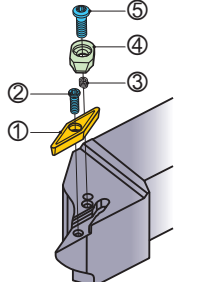
Type	Structure	
<b>Double Clamp</b> <b>(DOUBLE CLAMP)</b> <b>Holder</b>		
<b>Multiple Clamp</b> <b>For insert with hole</b> <b>(M Holder)</b>		
<b>Multiple Clamp</b> <b>For insert without hole</b> <b>(Opt.)</b> <b>(M Holder)</b>		
<b>Screw Clamp</b> <b>(SP Holder)</b> <b>(AL Holder)</b> <b>(SR Holder)</b>		
<b>Double Clamp with</b> <b>Screw and Clamp Bridge</b> <b>(PROFILE Holder)</b>		







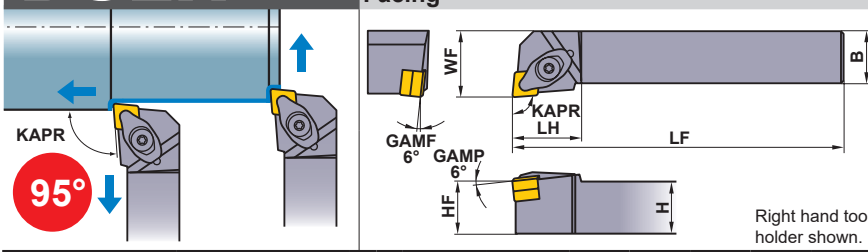

# EXTERNAL TURNING TOOLS

## CN INSERTS TOOL HOLDERS

DCLN

**External turning DOUBLE CLAMP Type Facing**



Finish	Light	Medium	Medium
FP  (4)	LP  (4)	MP  (4)	MK  (4)
Medium Standard  (3,4)	Medium to Rough RP  (4)	Stainless MM  (4)	CBN  (4)

C

EXTERNAL TURNING TOOLS

Order Number	ANSI Number	Stock		Insert Number	Dimensions (inch)						Shim	Shim Pin	Clamp Bridge	Spring	Clamp Screw <sup>*2</sup>	Wrench
		R	L		H	B	LF	LH	HF	WF						
DCLNR/L-123	DCLNR/L123B	●	●	32	.750	.750	4.500	1.000	.750	1.000	LLSCN33 (LLSCN32) <sup>*1</sup>	LLP23	DCK2211	DCS2	DC0520T	TKY15F
DCLNR/L-163	DCLNR/L163D	●	●		1.000	1.000	6.000	1.000	1.000	1.250						
DCLNR/L-124	DCLNR/L124B	●	●	43	.750	.750	4.500	1.250	.750	1.000	LLSCN42	LLP14	DCK2613	DCS1	DC0621T	TKY20F
DCLNR/L-164	DCLNR/L164D	●	●		1.000	1.000	6.000	1.250	1.000	1.250						
DCLNR/L-204	DCLNR/L204D	●	●		1.250	1.250	6.000	1.250	1.250	1.500						
DCLNR/L-244	DCLNR/L244D	●	●		1.500	1.500	6.000	1.250	1.500	2.000						

\*1 Please use shim no.LLSCN32 with .187inch thick insert. When using .187inch thick inserts, the shim must be ordered separately.

\*2 Clamp Torque (lbf-in) : DC0520T=31, DC0621T=44

Note 1) Insert photo is an example. Letters show chip breaker style, figures show inscribed circle.

C006

● : USA Stock

DCLN type inserts	➤ A106–A113
CBN & PCD inserts	➤ B022–B024, B049
CUTTING CONDITIONS	➤ A080, B008



# MCLN

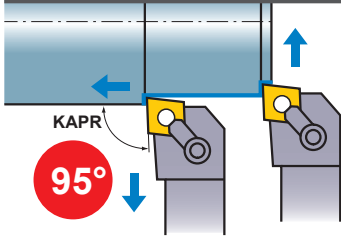

## External turning Facing Multiple Clamp Type M Holder

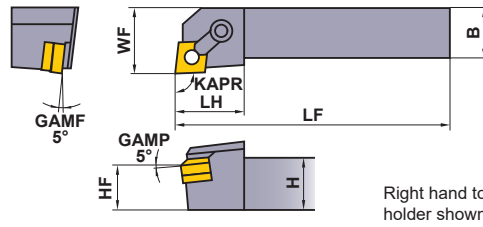

Right hand tool holder shown.

Finish	Light	Medium	Medium
FP (4)	LP (4)	MP (4,5)	MK (4,5,6)
Medium Standard (3,4,5,6)	Medium to Rough RP (4)	Stainless MM (3,4,5,6)	CBN (4)

Order Number	ANSI Number	Stock		Insert Number	Dimensions (inch)						Shim	Shim Pin	Clamp Bridge	Clamp Screw	
		R	L		H	B	LF	LH	HF	WF					
MCLNR/L-123	MCLNR/L123B	●	●	CNMA CNMG CNMM CNGA CNGG CNGM	32	.750	.750	4.500	1.000	.750	1.000	ICSN332	NL34L	CL6	XNS37
MCLNR/L-163	MCLNR/L163C	●	●		32	1.000	1.000	5.000	1.000	1.000	1.250				
MCLNR/L-124B	MCLNR/L124B	●	●		32	.750	.750	4.500	1.250	.750	1.000				
MCLNR/L-164C	MCLNR/L164C	●	●		32	1.000	1.000	5.000	1.250	1.000	1.250	ICSN433 <sup>*1</sup>	NL46	CL20	XNS48
MCLNR/L-164D	MCLNR/L164D	●	●		32	1.000	1.000	6.000	1.250	1.000	1.250				
MCLNR/L-204D	MCLNR/L204D	●	●		43 <sup>*2</sup>	1.250	1.250	6.000	1.250	1.250	1.500				
MCLNR/L-244D	MCLNR/L244D	●	●		43 <sup>*2</sup>	1.500	1.500	6.000	1.250	1.500	2.000	ICSN533	NL58	CL12	XNS510
MCLNR/L-244E	MCLNR/L244E	●	●		43 <sup>*2</sup>	1.500	1.500	7.000	1.250	1.500	2.000				
MCLNR/L-854D	MCLNR/L854D	●	●		43 <sup>*2</sup>	1.250	1.000	6.000	1.250	1.250	1.250				
MCLNR/L-165C	MCLNR/L165C	●	●		54	1.000	1.000	5.000	1.375	1.000	1.250	ICSN633	NL68	CL12	XNS510
MCLNR/L-165D	MCLNR/L165D	●	●		54	1.000	1.000	6.000	1.375	1.000	1.250				
MCLNR/L-205D	MCLNR/L205D	●	●		54	1.250	1.250	6.000	1.375	1.250	1.500				
MCLNR/L-166C	MCLNR/L166C	●	●		64	1.000	1.000	5.000	1.500	1.000	1.250	ICSN633	NL68	CL12	XNS510
MCLNR/L-166D	MCLNR/L166D	●	●		64	1.000	1.000	6.000	1.500	1.000	1.250				
MCLNR/L-206D	MCLNR/L206D	●	●		64	1.250	1.250	6.000	1.500	1.250	1.500				
MCLNR/L-246D	MCLNR/L246D	●	●		64	1.500	1.500	6.000	1.500	1.500	2.000	ICSN633	NL68	CL12	XNS510
MCLNR/L-246E	MCLNR/L246E	●	●		64	1.500	1.500	7.000	1.500	1.500	2.000				
MCLNR/L-856D	MCLNR/L856D	●	●		64	1.250	1.000	6.000	1.500	1.250	1.250				

\*1 (Opt.) See page M012 for different radius.

\*3 Clamp Torque (lbf-in) : XNS36=30, XNS48=45, XNS510=70

\*2 For inserts without hole, remove shim pin and add below.

Shim Screw	Chipbreaker
S46	CBC4

EXTERNAL TURNING TOOLS

MCLN type inserts > A106-A113  
 CBN & PCD inserts > B022-B024, B049  
 CUTTING CONDITIONS > A080, B008

SPARE PARTS > M001  
 TECHNICAL DATA > N001







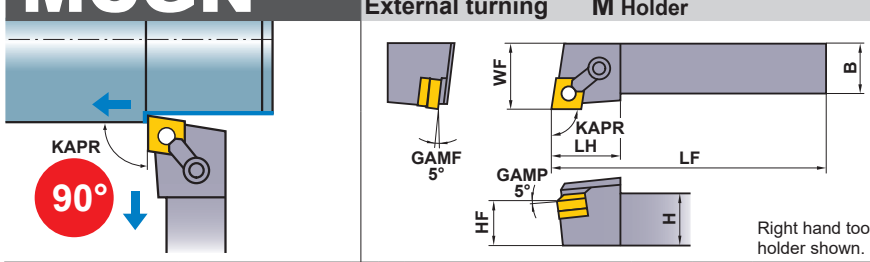

# EXTERNAL TURNING TOOLS

## CN INSERTS TOOL HOLDERS

### MCGN

**External turning Multiple Clamp Type M Holder**



Finish	Light	Medium	Medium
FP  (4)	LP  (4)	MP  (4,5)	MK  (4,5,6)
Medium Standard  (4,5,6)	Medium to Rough RP  (4,5,6)	Stainless MM  (4,5,6)	CBN  (4)

Order Number	ANSI Number	Stock		Insert Number	Dimensions (inch)						Shim	Shim Pin	Clamp Bridge	Clamp Screw	
		R	L		H	B	LF	LH	HF	WF					
MCGNR/L-124	MCGNR/L124B	●	□	CNMA CNMG CNMM CNGA CNGG CNGM	43 <sup>*2</sup>	.750	.750	4.500	1.250	.750	1.000	ICSN433 <sup>*1</sup>	NL46	CL20	XNS48
MCGNR/L-164C	MCGNR/L164C	□	●			1.000	1.000	5.000	1.250	1.000	1.250				
MCGNR/L-164D	MCGNR/L164D	●	●			1.000	1.000	6.000	1.250	1.000	1.250				
MCGNR/L-165D	MCGNR/L165D	●	●	54 <sup>○</sup>	1.000	1.000	6.000	1.375	1.000	1.250	ICSN533	NL58	CL12	XNS510	
MCGNR/L-166D	MCGNR/L166D	●	●		64 <sup>○</sup>	1.000	1.000	6.000	1.625	1.000	1.250	ICSN633	NL68	CL12	XNS510

\*1 (Opt.) See page M012 for different radius.

\*3 Clamp Torque (lbf-in) : XNS48=45, XNS510=70

\*2 For inserts without hole, remove shim pin and add below.

Shim Screw	Chipbreaker
S46	CBC4





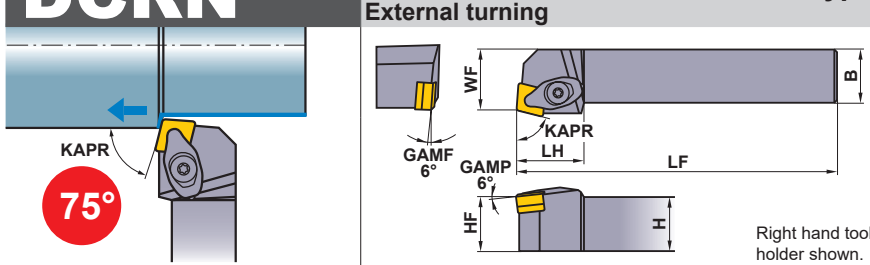

EXTERNAL TURNING TOOLS

C

### DCRN

**External turning DOUBLE CLAMP Type**



Finish	Light	Medium	Medium
FP  (4)	LP  (4)	MP  (4)	MK  (4)
Medium Standard  (4)	Medium to Rough RP  (4)	Stainless MM  (4)	

Order Number	ANSI Number	Stock		Insert Number	Dimensions (inch)							Shim	Shim Pin	Clamp Bridge	Spring	Clamp Screw	Wrench
		R	L		H	B	LF	LH	HF	WF							
DCRNR/L-124	DCRNR/L124B	●	●	CNMA CNMG CNMM CNGA CNGG	43 <sup>○</sup>	.750	.750	4.500	1.250	.750	.888	LLSCN42	LLP14	DCK2613	DCS1	DC0621T	TKY20F
DCRNR/L-164	DCRNR/L164D	●	●			1.000	1.000	6.000	1.250	1.000	1.128						

\* Clamp Torque (lbf-in) : DC0621T=44

Note 1) Insert photo is an example. Letters show chip breaker style, figures show inscribed circle.

MCGN type inserts > A106-A113

DCRN type inserts > A106-A113

CBN & PCD inserts > B022-B024, B049

CUTTING CONDITIONS > A080, B008

● : USA Stock □ : Made to Order

# MCRN

### External turning Multiple Clamp Type M Holder

Finish	Light	Medium	Medium
FP  (4)	LP  (4)	MP  (4,5)	MK  (4,5,6)
Medium Standard  (4,5,6)	Medium to Rough RP  (4)	Stainless MM  (4,5)	

Order Number	ANSI Number	Stock		Insert Number	Dimensions (inch)						Shim	Shim Pin	Clamp Bridge	Clamp Screw <sup>*3</sup>	
		R	L		H	B	LF	LH	HF	WF					
MCRNR/L-124B	MCRNR/L124B	●	□	CNMA CNMG CNMM CNGG	43 <sup>*2</sup>	.750	.750	4.500	1.250	.750	.750	ICSN433 <sup>*1</sup>	NL46	CL9	XNS48
MCRNR/L-164C	MCRNR/L164C	●	●		1.000	1.000	5.000	1.250	1.000	1.250					
MCRNR/L-164D	MCRNR/L164D	●	●		1.000	1.000	6.000	1.250	1.000	1.250					
MCRNR/L-165D	MCRNR/L165D	●	□		54 <sup>*2</sup>	1.000	1.000	6.000	1.375	1.000	1.250	ICSN533	NL58	CL9	XNS510
MCRNR/L-166D	MCRNR/L166D	□	●		64 <sup>*2</sup>	1.000	1.000	6.000	1.500	1.000	1.250	ICSN633	NL68	CL12	

\*1 (Opt.) See page M012 for different radius.

\*3 Clamp Torque (lbf-in) : XNS48=45, XNS510=70

\*2 For inserts without hole, remove shim pin and add below.

Shim Screw	Chipbreaker
S46	CBC4

# MCFN

### Facing Multiple Clamp Type M Holder

Finish	Light	Medium	Medium
FP  (4)	LP  (4)	MP  (4,5)	MK  (4,5,6)
Medium Standard  (4,5,6)	Medium to Rough RP  (4)	Stainless MM  (4,5)	CBN  (4)

Order Number	ANSI Number	Stock		Insert Number	Dimensions (inch)						Shim	Shim Pin	Clamp Bridge	Clamp Screw <sup>*3</sup>	
		R	L		H	B	LF	LH	HF	WF					
MCFNR/L-124	MCFNR/L124B	●	●	CNMA CNMG CNMM CNGG	43 <sup>*2</sup>	.750	.750	4.500	1.250	.750	1.000	ICSN433 <sup>*1</sup>	NL46	CL20	XNS48
MCFNR/L-164C	MCFNR/L164C	●	●		1.000	1.000	5.000	1.250	1.000	1.250					
MCFNR/L-164D	MCFNR/L164D	●	●		1.000	1.000	6.000	1.250	1.000	1.250					
MCFNR/L-165D	MCFNR/L165D	●	●		54 <sup>*2</sup>	1.000	1.000	6.000	1.375	1.000	1.250	ICSN533	NL58	CL12	XNS510
MCFNR/L-166D	MCFNR/L166D	●	●		64 <sup>*2</sup>	1.000	1.000	6.000	1.500	1.000	1.250	ICSN633	NL68	CL9	

\*1 (Opt.) See page M012 for different radius.

\*3 Clamp Torque (lbf-in) : XNS48=45, XNS510=70

\*2 For inserts without hole, remove shim pin and add below.

Shim Screw	Chipbreaker
S46	CBC4

MCRN type inserts	> A106-A113
MCFN type inserts	> A106-A113
CBN & PCD inserts	> B049

CUTTING CONDITIONS	> A080, B008
SPARE PARTS	> M001
TECHNICAL DATA	> N001

# EXTERNAL TURNING TOOLS

## DN INSERTS TOOL HOLDERS

### DDJN

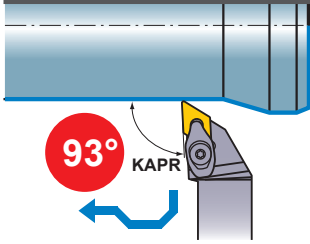

External turning **DOUBLE CLAMP Type**  
Copying

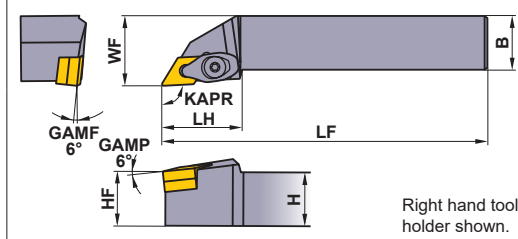

Finish	Light	Medium	Medium
FP (4)	LP (4)	MP (4)	MK (4)
Medium to Rough	Stainless	G Class	CBN
RP (4)	MM (4)	R/L (4)	(4)

EXTERNAL TURNING TOOLS

C

Order Number	ANSI Number	Stock		Insert Number	Dimensions (inch)						Shim	Shim Pin	Clamp Bridge	Spring	Clamp Screw	Wrench
		R	L		H	B	LF	LH	HF	WF						
DDJNR/L-123	DDJNR/L123B	●	●	33	.750	.750	4.500	1.188	.750	1.000	LLSDN32	LLP23	DCK2211	DCS2	DC0520T	TKY15F
DDJNR/L-163	DDJNR/L163D	●	●		1.000	1.000	6.000	1.188	1.000	1.250						
DDJNR/L-124	DDJNR/L124B	●	●	43	.750	.750	4.500	1.375	.750	1.000	LLSDN43 (LLSDN42)	LLP24 (LLP14)	DCK2613	DCS1	DC0621T	TKY20F
DDJNR/L-164	DDJNR/L164D	●	●		1.000	1.000	6.000	1.375	1.000	1.250						
DDJNR/L-204	DDJNR/L204D	●	●		1.250	1.250	6.000	1.375	1.250	1.500						
DDJNR/L-244	DDJNR/L244D	●	●		1.500	1.500	6.000	1.500	1.500	2.000						

\*1 Please use shim no.LLSDN42 and shim pin LLP14 with .25inch thick insert. When using .25inch thick inserts, the shim and shim pin must be ordered separately.

\*2 Clamp Torque (lbf-in) : DC0520T=31, DC0621T=44

### MDJN

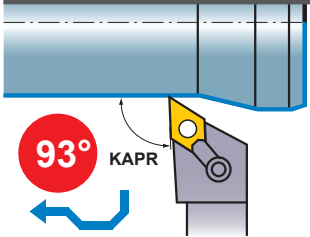

External turning **Multiple Clamp Type**  
Copying  
M Holder

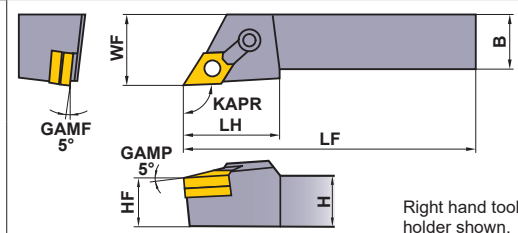

Finish	Light	Medium	Medium
FP (4)	LP (4)	MP (4)	MK (4)
Medium to Rough	Stainless	G Class	CBN
RP (4)	MM (4)	R/L (4)	(4)

Order Number	ANSI Number	Stock		Insert Number	Dimensions (inch)						Shim	Shim Pin	Clamp Bridge	Clamp Screw
		R	L		H	B	LF	LH	HF	WF				
MDJNR/L-123	MDJNR/L123B	●	●	33	.750	.750	4.500	1.250	.750	1.000	IDSN322	NL34L	CL7	XNS36
MDJNR/L-163	MDJNR/L163C	●	●		1.000	1.000	5.000	1.250	1.000	1.250				
MDJNR/L-124B	MDJNR/L124B	●	●	43	.750	.750	4.500	1.250	.750	1.000	IDSN433	NL46	CL7	XNS36
MDJNR/L-164C	MDJNR/L164C	●	●		1.000	1.000	5.000	1.250	1.000	1.250				
MDJNR/L-164D	MDJNR/L164D	●	●		1.000	1.000	6.000	1.250	1.000	1.250				
MDJNR/L-204D	MDJNR/L204D	●	●		1.250	1.250	6.000	1.250	1.250	1.500				
MDJNR/L-244D	MDJNR/L244D	●	●	1.500	1.500	6.000	1.250	1.500	2.000	IDSN533	NL58	CL12	XNS510	
MDJNR/L-165D	MDJNR/L165D	●	●	54	1.000	1.000	6.000	1.750	1.000					1.250
MDJNR/L-205D	MDJNR/L205D	●	●		1.250	1.250	6.000	1.750	1.250					1.500

\*1 (Opt.) See page M012 for different thickness.

\*2 Clamp Torque (lbf-in) : XNS36=30, XNS48=45, XNS510=70

Note 1) Insert photo is an example. Letters show chip breaker style, figures show inscribed circle.

● : USA Stock

DDJN type inserts > A114-A121

MDJN type inserts > A114-A121

CUTTING CONDITIONS > A080, B008





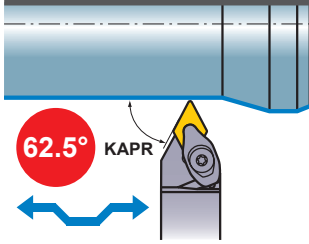

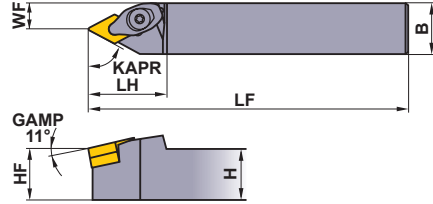

CBN & PCD inserts > B025-B028, B049

# DDPN



## External turning DOUBLE CLAMP Type Copying



Finish	Light	Medium	Medium
FP	LP	MP	MK
 (4)	 (4)	 (4)	 (4)
Medium to Rough	Stainless	G Class	CBN
RP	MM	R/L	
 (4)	 (4)	 (4)	 (4)

Order Number	ANSI Number	Stock	Insert Number	Dimensions (inch)						Shim	Shim Pin	Clamp Bridge	Spring	Clamp Screw	Wrench												
				H	B	LF	LH	HF	WF																		
<b>DDPNN-164</b>	<b>DDPNN164D</b>	●	<table border="1"> <tr><td>DNMA</td></tr> <tr><td>DNMG</td></tr> <tr><td>DNMM</td></tr> <tr><td>DNMG</td></tr> <tr><td>DNMG</td></tr> <tr><td>DNMG</td></tr> <tr><td>DNMG</td></tr> <tr><td>DNMG</td></tr> <tr><td>DNMG</td></tr> <tr><td>DNMG</td></tr> <tr><td>DNMG</td></tr> </table>	DNMA	DNMG	DNMM	DNMG	DNMG	DNMG	DNMG	DNMG	DNMG	DNMG	DNMG	43	1.000	1.000	6.000	1.500	1.000	.500	LLSDN43 (LLSDN42)*1	LLP24 (LLP14)*1	DKK2613	DCS1	DC0621T	TKY20F
DNMA																											
DNMG																											
DNMM																											
DNMG																											
DNMG																											
DNMG																											
DNMG																											
DNMG																											
DNMG																											
DNMG																											
DNMG																											

\*1 Please use shim no.LLSDN42 and shim pin LLP14 with .25inch thick insert. When using .25inch thick inserts, the shim and shim pin must be ordered separately.





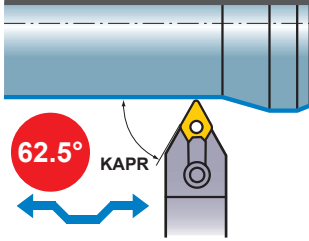

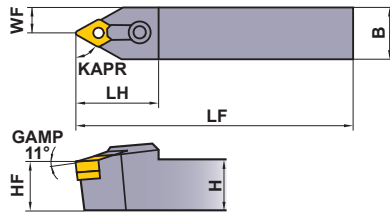

\*2 Clamp Torque (lbf-in) : DC0621T=44

# MDPN



## External turning Multiple Clamp Type M Holder Copying



Finish	Light	Medium	Medium
FP	LP	MP	MK
 (4)	 (4)	 (4)	 (4)
Medium to Rough	Stainless	G Class	CBN
RP	MM	R/L	
 (4)	 (4)	 (4)	 (4)

Order Number	ANSI Number	Stock	Insert Number	Dimensions (inch)						Shim	Shim Pin	Clamp Bridge	Clamp Screw												
				H	B	LF	LH	HF	WF																
<b>MDPNN-164D</b>	<b>MDPNN164D</b>	●	<table border="1"> <tr><td>DNMA</td></tr> <tr><td>DNMG</td></tr> <tr><td>DNMM</td></tr> <tr><td>DNMG</td></tr> <tr><td>DNMG</td></tr> <tr><td>DNMG</td></tr> <tr><td>DNMG</td></tr> <tr><td>DNMG</td></tr> <tr><td>DNMG</td></tr> <tr><td>DNMG</td></tr> <tr><td>DNMG</td></tr> </table>	DNMA	DNMG	DNMM	DNMG	DNMG	DNMG	DNMG	DNMG	DNMG	DNMG	DNMG	43	1.000	1.000	6.000	1.750	1.000	.500	IDSN433	NL46	CL12	XNS510
DNMA																									
DNMG																									
DNMM																									
DNMG																									
DNMG																									
DNMG																									
DNMG																									
DNMG																									
DNMG																									
DNMG																									
DNMG																									
<b>MDPNN-165D</b>	<b>MDPNN165D</b>	●	<table border="1"> <tr><td>DNMA</td></tr> <tr><td>DNMG</td></tr> <tr><td>DNMM</td></tr> <tr><td>DNMG</td></tr> <tr><td>DNMG</td></tr> <tr><td>DNMG</td></tr> <tr><td>DNMG</td></tr> <tr><td>DNMG</td></tr> <tr><td>DNMG</td></tr> <tr><td>DNMG</td></tr> <tr><td>DNMG</td></tr> </table>	DNMA	DNMG	DNMM	DNMG	DNMG	DNMG	DNMG	DNMG	DNMG	DNMG	DNMG	54 <sup>*1</sup>	1.000	1.000	6.000	2.000	1.000	.500	IDSN533 <sup>*1</sup>	NL58		
DNMA																									
DNMG																									
DNMM																									
DNMG																									
DNMG																									
DNMG																									
DNMG																									
DNMG																									
DNMG																									
DNMG																									
DNMG																									

\*1 (Opt.) See page M012 for different thickness.

\*2 Clamp Torque (lbf-in) : XNS510=70

DDPN type inserts	> A114-A121
MDPN type inserts	> A114-A121
CBN & PCD inserts	> B025-B028, B049

CUTTING CONDITIONS	> A080, B008
SPARE PARTS	> M001
TECHNICAL DATA	> N001

# EXTERNAL TURNING TOOLS

## DN INSERTS TOOL HOLDERS

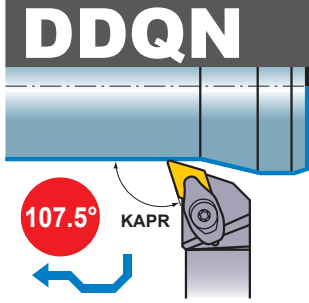

### External turning DOUBLE CLAMP Type Copying

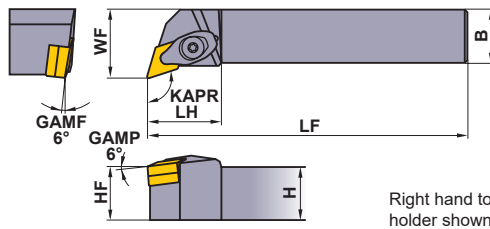

Right hand tool holder shown.

Finish	Light	Medium	Medium
FP (4)	LP (4)	MP (4)	MK (4)
Medium to Rough	Stainless	G Class	CBN
RP (4)	MM (4)	R/L (4)	(4)

C

EXTERNAL TURNING TOOLS

Order Number	ANSI Number	Stock		Insert Number	Dimensions (inch)						Shim	Shim Pin	Clamp Bridge	Spring	Clamp Screw	Wrench																															
		R	L		H	B	LF	LH	HF	WF																																					
DDQNR/L-164	DDQNR/L164D	●	●	<table border="1"> <tr><td>DD</td><td>DN</td><td>MA</td></tr> <tr><td>DD</td><td>DN</td><td>MG</td></tr> <tr><td>DD</td><td>DN</td><td>MG</td></tr> <tr><td>DD</td><td>DN</td><td>MG</td></tr> <tr><td>DD</td><td>DN</td><td>MG</td></tr> <tr><td>DD</td><td>DN</td><td>MG</td></tr> <tr><td>DD</td><td>DN</td><td>MG</td></tr> <tr><td>DD</td><td>DN</td><td>MG</td></tr> <tr><td>DD</td><td>DN</td><td>MG</td></tr> <tr><td>DD</td><td>DN</td><td>MG</td></tr> </table>	DD	DN	MA	DD	DN	MG	DD	DN	MG	DD	DN	MG	DD	DN	MG	DD	DN	MG	DD	DN	MG	DD	DN	MG	DD	DN	MG	DD	DN	MG	43	1.000	1.000	6.000	1.375	1.000	1.250	LLSDN43 (LLSDN42)	LLP24 (LLP14)	DCK2613	DCS1	DC0621T	TKY20F
DD	DN	MA																																													
DD	DN	MG																																													
DD	DN	MG																																													
DD	DN	MG																																													
DD	DN	MG																																													
DD	DN	MG																																													
DD	DN	MG																																													
DD	DN	MG																																													
DD	DN	MG																																													
DD	DN	MG																																													



\*1 Please use shim no.LLSDN42 and shim pin LLP14 with .25inch thick insert. When using .25inch thick inserts, the shim and shim pin must be ordered separately.  
 \*2 Clamp Torque (lbf-in) : DC0621T=44

Note 1) Insert photo is an example. Letters show chip breaker style, figures show inscribed circle.

● : USA Stock    □ : Made to Order

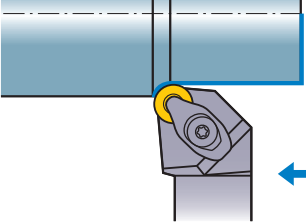
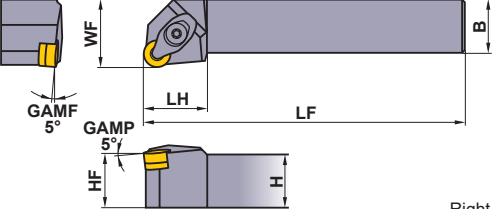

DDQN type inserts	> A114–A121
CBN & PCD inserts	> B025–B028, B049
CUTTING CONDITIONS	> A080, B008

# RN INSERTS TOOL HOLDERS

<b>DRGN</b>		External turning Copying		DOUBLE CLAMP Type							Medium Standard						
											 (4)						
											Medium Flat Top						
											 (4)						
											Right hand tool holder shown.						
Order Number	ANSI Number	Stock		Insert Number	Dimensions (inch)						Shim	Shim Pin	Clamp Bridge	Spring	Clamp Screw	* Wrench	
		R	L		H	B	LF	LH	HF	WF							
DRGNR/L-124	DRGNR/L124B	●	●	RNMG	43	.750	.750	4.500	1.188	.750	1.000						
DRGNR/L-164	DRGNR/L164D	●	●			1.000	1.000	6.000	1.188	1.000	1.250	LLSRN42	LLP14	DCK2613	DCS1	DC0621T	TKY20F
DRGNR/L-204	DRGNR/L204D	●	●			1.250	1.250	6.000	1.188	1.250	1.500						

\* Clamp Torque (lbf-in) : DC0621T=44

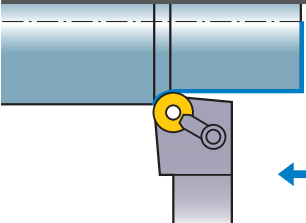
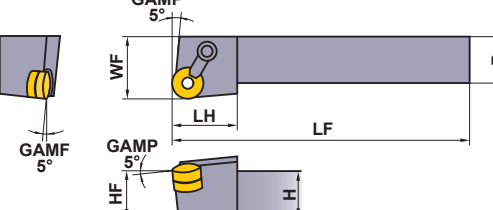
EXTERNAL TURNING TOOLS

<b>MRGN</b>		External turning Copying		Multiple Clamp Type M Holder							Medium Standard				
											 (3,4,6)				
											Medium Flat Top				
											 (4)				
											Right hand tool holder shown.				
Order Number	ANSI Number	Stock		Insert Number	Dimensions (inch)						Shim	Shim Pin	Clamp Bridge	*3 Clamp Screw	
		R	L		H	B	LF	LH	HF	WF					
MRGNR/L-123B	MRGNR/L123B	●	●	RNMG	32	.750	.750	4.500	.875	.750	1.000	IRSN32	NL34	CL6	XNS36
MRGNR/L-163	MRGNR/L163D	□	□			1.000	1.000	6.000	.875	1.000	1.250				
MRGNR/L-124B	MRGNR/L124B	●	●			43	*1*2	.750	.750	4.500	1.250	.750	1.000	IRSN43	NL46
MRGNR/L-164C	MRGNR/L164C	●	●	1.000	1.000			5.000	1.250	1.000	1.250				
MRGNR/L-164D	MRGNR/L164D	●	●	1.000	1.000			6.000	1.250	1.000	1.250				
MRGNR/L-204D	MRGNR/L204D	●	□			1.250	1.250	6.000	1.250	1.250	1.500				
MRGNR/L-206D	MRGNR/L206D	●	□			1.250	1.250	6.000	1.375	1.250	1.500	IRSN63	NL68	CL12	XNS58
MRGNR/L-246	MRGNR/L246E	□	□			1.500	1.500	7.000	1.375	1.500	2.000				

\*1 (Opt.) See page M012 for different thickness.

\*3 Clamp Torque (lbf-in) : XNS36=30, XNS58=70, XNS59=70

\*2 For inserts without hole, remove shim pin and add below.

Shim Screw	Chipbreaker
S46	CBR4

DRGN type inserts > A122  
MRGN type inserts > A122







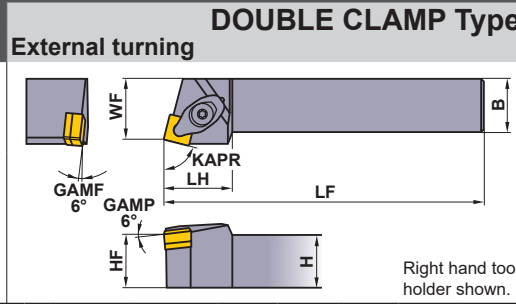
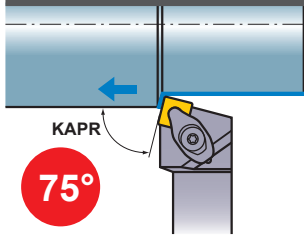

CUTTING CONDITIONS > A080  
SPARE PARTS > M001  
TECHNICAL DATA > N001

# EXTERNAL TURNING TOOLS

## SN INSERTS TOOL HOLDERS

### DSRN









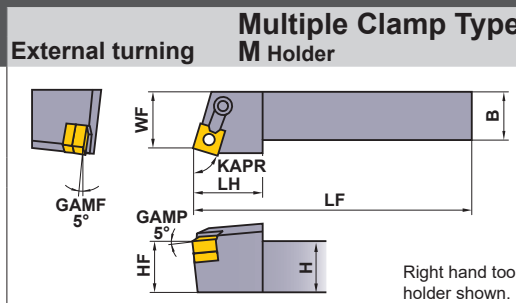
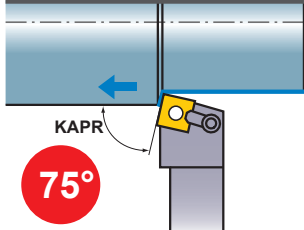

Finish	Light	Medium	Medium
FP  (4)	LP  (4)	MP  (4)	MK  (4)
Medium to Rough RP  (4)	Stainless MM  (4)	G Class R/L  (4)	CBN  (4)

Order Number	ANSI Number	Stock		Insert Number	Dimensions (inch)						Shim	Shim Pin	Clamp Bridge	Spring	Clamp Screw	Wrench
		R	L		H	B	LF	LH	HF	WF						
DSRNR/L-124	DSRNR/L124B	●	●	43	.750	.750	4.500	1.250	.750	.878	LLSSN42	LLP14	DCK2613	DCS1	DC0621T	TKY20F
DSRNR/L-164	DSRNR/L164D	●	●		1.000	1.000	6.000	1.250	1.000	1.128						

\* Clamp Torque (lbf-in) : DC0621T=44

### MSRN



Finish	Light	Medium	Medium
FP  (3,4)	LP  (4)	MP  (4)	MK  (4,6)
Medium to Rough RP  (4)	Stainless MM  (4,5)	G Class R/L  (4)	CBN  (4)

Order Number	ANSI Number	Stock		Insert Number	Dimensions (inch)						Shim	Shim Pin	Clamp Bridge	Clamp Screw	
		R	L		H	B	LF	LH	HF	WF					
MSRNR/L-83	MSRNR/L083B	●	●	SNMA SNMG SNMM SNGA SNGG	.500	.500	4.500	1.000	.500	.660	ISSN322	NL34	CL6	XNS36	
MSRNR/L-103	MSRNR/L103B	●	●		32	.625	.625	4.500	1.000	.625					.785
MSRNR/L-123	MSRNR/L123B	●	●		43	.750	.750	4.500	1.000	.750	.910	ISSN433	NL46	CL9	XNS59
MSRNR/L-124B	MSRNR/L124B	●	●			.750	.750	4.500	1.250	.750	.880				
MSRNR/L-164C	MSRNR/L164C	●	●		1.000	1.000	5.000	1.250	1.000	1.130	ISSN533	NL58	CL12	XNS510	
MSRNR/L-164D	MSRNR/L164D	●	●		1.000	1.000	6.000	1.250	1.000	1.130					
MSRNR/L-165C	MSRNR/L165C	●	●		54	1.000	1.000	5.000	1.375	1.000	1.103	ISSN633	NL68	CL12	XNS510
MSRNR/L-165D	MSRNR/L165D	●	●			1.000	1.000	6.000	1.375	1.000	1.103				
MSRNR/L-205D	MSRNR/L205D	●	●		64	1.250	1.250	6.000	1.375	1.250	1.353	ISSN846	NL810	CL24	XNS610
MSRNR/L-166	MSRNR/L166D	●	●			1.000	1.000	6.000	1.500	1.000	1.071				
MSRNR/L-206D	MSRNR/L206D	●	●			1.250	1.250	6.000	1.500	1.250	1.315				
MSRNR/L-246D	MSRNR/L246D	●	●			1.500	1.500	6.000	1.500	1.500	1.821				
MSRNR/L-246E	MSRNR/L246E	●	●		1.500	1.500	7.000	1.500	1.500	1.821					
MSRNR/L-248	MSRNR/L248E	●	●		86	1.500	1.500	7.000	1.625	1.500	1.768				

\*1 (Opt.) See page M012 for different thickness or radius.

\*2 For inserts without hole, remove shim pin and add below.

\*3 Clamp Torque (lbf-in) : XNS36=30, XNS59=70, XNS510=70, XNS610=135

Insert	Shim Screw	Chippbreaker
SN3	S34	CBS3
SN4	S46	CBS4

Note 1) Insert photo is an example. Letters show chip breaker style, figures show inscribed circle.

● : USA Stock □ : Made to Order

DSRN type inserts > A123-A129  
MSRN type inserts > A123-A129

CBN & PCD inserts > B029, B050  
CUTTING CONDITIONS > A080, B008



DSSN		External turning DOUBLE CLAMP Type Chamfering								Finish	Light	Medium	Medium			
										FP  (4)	LP  (4)	MP  (4)	MK  (4)			
Order Number	ANSI Number	Stock		Insert Number	Dimensions (inch)						Shim	Shim Pin	Clamp Bridge	Spring	Clamp Screw	* Wrench
		R	L		H	B	LF	LH	HF	WF						
DSSNR/L-124	DSSNR/L124B	●	●	 43	.750	.750	4.500	1.250	.750	.659	LLSSN42	LLP14	DCK2613	DCS1	DC0621T	TKY20F
DSSNR/L-164	DSSNR/L164D	●	●		1.000	1.000	6.000	1.250	1.000	.909						

\* Clamp Torque (lbf-in) : DC0621T=44

MSSN		External turning Multiple Clamp Type M Holder Chamfering								Finish	Light	Medium	Medium	
										FP  (3,4)	LP  (4)	MP  (4)	MH  (4,6)	
Order Number	ANSI Number	Stock		Insert Number	Dimensions (inch)						Shim	Shim Pin	Clamp Bridge	*3 Clamp Screw
		R	L		H	B	LF	LH	HF	WF				
MSSNR/L-83	MSSNR/L083B	●	●	 32 <sup>*1*2</sup> 43 <sup>*1*2</sup> 54 <sup>*</sup> 64 <sup>*1</sup>	.500	.500	4.500	1.000	.500	.404	ISSN322 <sup>*1</sup>	NL34	CL6	XNS36
MSSNR/L-124B	MSSNR/L124B	●	●		.750	.750	4.500	1.250	.750	.675				
MSSNR/L-164C	MSSNR/L164C	□	□		1.000	1.000	5.000	1.250	1.000	.925	ISSN433 <sup>*1</sup>	NL46	CL9	XNS59
MSSNR/L-164D	MSSNR/L164D	●	●		1.000	1.000	6.000	1.250	1.000	.925				
MSSNR/L-205D	MSSNR/L205D	□	□		1.250	1.250	6.000	1.375	1.250	1.097	ISSN533	NL58	CL12	XNS510
MSSNR/L-206D	MSSNR/L206D	□	●		1.250	1.250	6.000	1.500	1.250	1.011	ISSN633 <sup>*1</sup>	NL68	CL12	XNS510

\*1 (Opt.) See page M012 for different thickness or radius.

\*3 Clamp Torque (lbf-in) : XNS36=30, XNS59=70, XNS510=70

\*2 For inserts without hole, remove shim pin and add below.

Insert	Shim Screw	Chipbreaker
SN <sup>○</sup> N3 <sup>○○</sup>	S34	CBS3D
SN <sup>○</sup> N4 <sup>○○</sup>	S46	CBS4D

DSSN type inserts	> A123-A129
MSSN type inserts	> A123-A129
CBN & PCD inserts	> B029, B050

CUTTING CONDITIONS	> A080, B008
SPARE PARTS	> M001
TECHNICAL DATA	> N001







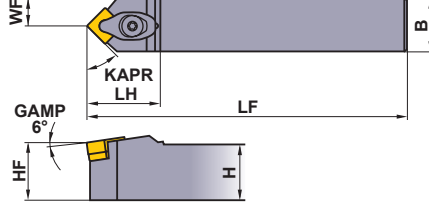
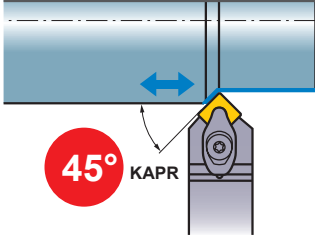

# EXTERNAL TURNING TOOLS

## SN INSERTS TOOL HOLDERS

### DSDN

External turning **DOUBLE CLAMP Type**  
Chamfering



Finish	Light	Medium	Medium
FP	LP	MP	MK
 (4)	 (4)	 (4)	 (4)
Medium to Rough	Stainless	G Class	CBN
RP	MM	R/L	
 (4)	 (4)	 (4)	 (4)

Order Number	ANSI Number	Stock	Insert Number	Dimensions (inch)						Shim	Shim Pin	Clamp Bridge	Spring	Clamp Screw	Wrench	
				H	B	LF	LH	HF	WF							
DSDNN-124	DSDNN124B	●	SNMA SNMG SNMM SNGA SNGG	43	.750	.750	4.500	1.375	.750	.375	LLSSN42	LLP14	DCK2613	DCS1	DC0621T	TKY20F
DSDNN-164	DSDNN164D	●		1.000	1.000	6.000	1.375	1.000	.500							







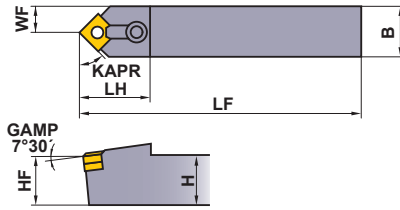
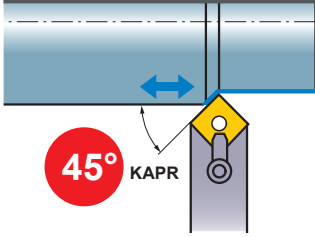

\* Clamp Torque (lbf-in) : DC0621T=44

EXTERNAL TURNING TOOLS

### MSDN

External turning **Multiple Clamp Type**  
Chamfering **M Holder**



Finish	Light	Medium	Medium
FP	LP	MP	MK
 (3,4)	 (4)	 (4)	 (4,5,6)
Medium to Rough	Stainless	G Class	CBN
GH	MM	R/L	
 (4,5,6)	 (3,4,5,6)	 (4)	 (4)

Order Number	ANSI Number	Stock	Insert Number	Dimensions (inch)						Shim	Shim Pin	Clamp Bridge	Clamp Screw	
				H	B	LF	LH	HF	WF					
MSDNN-83	MSDNN083B	●	SNMA SNMG SNMM SNGA SNGG	32	.500	.500	4.500	1.000	.500	.250	ISSN322	NL34	CL6	XNS36
MSDNN-103	MSDNN103B	□		*1*2	.625	.625	4.500	1.000	.625	.313				
MSDNN-123	MSDNN123B	●		32	.750	.750	4.500	1.000	.750	.375	ISSN433	NL46	CL9	XNS59
MSDNN-124	MSDNN124B	●		*1*2	.750	.750	4.500	1.375	.750	.375				
MSDNN-164	MSDNN164D	●		43	1.000	1.000	6.000	1.375	1.000	.500	ISSN533	NL58	CL12	XNS510
MSDNN-165	MSDNN165D	●		54	1.000	1.000	6.000	1.625	1.000	.500				
MSDNN-166	MSDNN166D	●		64	1.000	1.000	6.000	1.750	1.000	.500	ISSN633	NL68	CL12	XNS510
MSDNN-206	MSDNN206E	●		*1	1.250	1.250	7.000	1.750	1.250	.625				

\*1 (Opt.) See page M012 for different thickness or radius.

\*2 For inserts without hole, remove shim pin and add below.

\*3 Clamp Torque (lbf-in) : XNS36=30, XNS59=70, XNS510=70

Insert	Shim Screw	Chipbreaker
SN $\circ$ N3 $\circ$	S34	CBS3D
SN $\circ$ N4 $\circ$	S46	CBS4D

Note 1) Insert photo is an example. Letters show chip breaker style, figures show inscribed circle.

● : USA Stock □ : Made to Order

DSDN type inserts > A123-A129  
MSDN type inserts > A123-A129





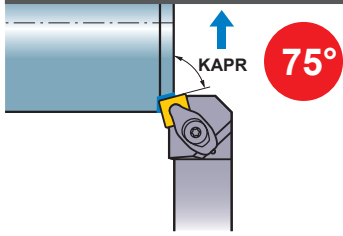

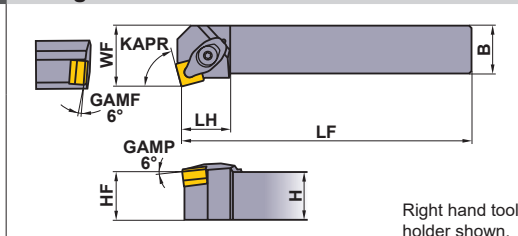

CBN & PCD inserts > B029, B050  
CUTTING CONDITIONS > A080, B008

# DSKN



## DOUBLE CLAMP Type



Finish	Light	Medium	Medium
FP  (4)	LP  (4)	MP  (4)	MK  (4)
Medium to Rough RP  (4)	Stainless MM  (4)	G Class R/L  (4)	CBN  (4)

Order Number	ANSI Number	Stock		Insert Number	Dimensions (inch)						Shim	Shim Pin	Clamp Bridge	Spring	Clamp Screw	* Wrench	
		R	L		H	B	LF	LH	HF	WF							
DSKNR/L-124	DSKNR/L124B	●	●	SNMA SNMG SNMM SNGA SNGG	43	.750	.750	4.500	1.000	.750	1.000	LLSSN42	LLP14	DCK2613	DCS1	DC0621T	TKY20F
DSKNR/L-164	DSKNR/L164D	●	●			1.000	1.000	6.000	1.000	1.000	1.250						

\* Clamp Torque (lbf-in) : DC0621T=44





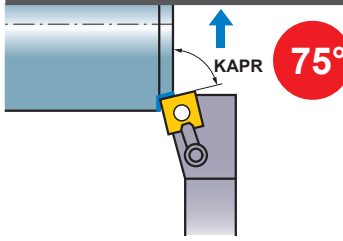

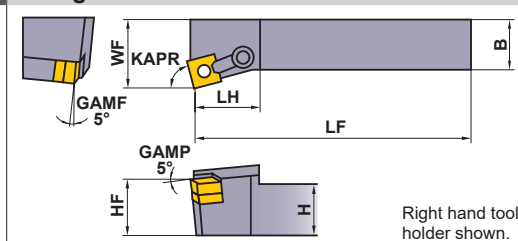

EXTERNAL TURNING TOOLS

# MSKN



## Multiple Clamp Type M Holder



Finish	Light	Medium	Medium
FP  (3,4)	LP  (4)	MP  (4)	MK  (4,5,6)
Medium to Rough RP  (4)	Stainless MM  (3,4,5,6)	G Class R/L  (4)	CBN  (4)

Order Number	ANSI Number	Stock		Insert Number	Dimensions (inch)						Shim	Shim Pin	Clamp Bridge	Clamp Screw	
		R	L		H	B	LF	LH	HF	WF					
MSKNR/L-83	MSKNR/L083B	●	●	SNMA SNMG SNMM SNGA SNGG	32	.500	.500	4.500	1.000	.500	.625	ISSN322	NL34	CL6	XNS36
MSKNR/L-103	MSKNR/L103B	●	●			.625	.625	4.500	1.000	.625	.750				
MSKNR/L-123	MSKNR/L123B	●	●			.750	.750	4.500	1.000	.750	.875	ISSN433	NL46	CL9	XNS59
MSKNR/L-124B	MSKNR/L124B	●	●			.750	.750	4.500	1.250	.750	1.000				
MSKNR/L-164D	MSKNR/L164D	●	●			1.000	1.000	6.000	1.000	1.000	1.250	ISSN533	NL58	CL12	XNS510
MSKNR/L-165D	MSKNR/L165D	●	●			1.000	1.000	6.000	1.375	1.000	1.250				
MSKNR/L-205D	MSKNR/L205D	●	●			1.250	1.250	6.000	1.375	1.250	1.500	ISSN633	NL68	CL12	XNS510
MSKNR/L-206D	MSKNR/L206D	●	●			1.250	1.250	6.000	1.500	1.250	1.500				

\*1 (Opt.) See page M012 for different thickness or radius.

\*2 For inserts without hole, remove shim pin and add below.

\*3 Clamp Torque (lbf-in) : XNS36=30, XNS59=70, XNS510=70

Insert	Shim Screw	Chipbreaker
SN $\bar{N}$ 3 $\bar{O}$	S34	CBS3
SN $\bar{N}$ 4 $\bar{O}$	S46	CBS4

- DSKN type inserts > A123-A129
- MSKN type inserts > A123-A129
- CBN & PCD inserts > B029, B050

- CUTTING CONDITIONS > A080, B008
- SPARE PARTS > M001
- TECHNICAL DATA > N001

# EXTERNAL TURNING TOOLS

## TN INSERTS TOOL HOLDERS

MTJN

**External turning Multiple Clamp Type M Holder**

Right hand tool holder shown.

Finish	Light	Medium	Medium
FP  (3)	LP  (3)	MP  (3,4)	MK  (3,4)
Medium to Rough	Stainless	G Class	CBN
RP  (3)	MM  (3,4)	R/L  (3,4)	 (3)

EXTERNAL TURNING TOOLS

Order Number	ANSI Number	Stock		Insert Number	Dimensions (inch)						Shim	Shim Pin	Clamp Bridge	Clamp Screw	
		R	L		H	B	LF	LH	HF	WF					
MTJNR/L-123X	MTJNR/L123B	●	●	TNMA TNMG TNMX TNMM TNGA TNGG	33 <sup>○</sup> *1	.750	.750	4.500	1.000	.750	1.000	ITSN323 <sup>*1</sup>	NL34L	CL6	XNS36
MTJNR/L-163X	MTJNR/L163D	●	●		43 <sup>○</sup> *1	1.000	1.000	6.000	1.000	1.000	1.250	ITSN433 <sup>*1</sup>	NL46	CL9	XNS510
MTJNR/L-164	MTJNR/L164D	●	●		54 <sup>○</sup> *1	1.000	1.000	6.000	1.500	1.000	1.250				
MTJNR/L-204	MTJNR/L204D	●	●		54 <sup>○</sup> *1	1.250	1.250	6.000	1.250	1.250	1.500	ITSN533 <sup>*1</sup>	NL58	CL9	XNS510
MTJNR/L-854	MTJNR/L854D	●	●		66 <sup>○</sup> *1	1.250	1.000	6.000	1.250	1.250	1.250				
MTJNR/L-165	MTJNR/L165D	●	●		54 <sup>○</sup> *1	1.000	1.000	6.000	1.500	1.000	1.250	ITSN636 <sup>*1</sup>	NL68L	CL12	XNS510
MTJNR/L-205	MTJNR/L205D	●	●		66 <sup>○</sup> *1	1.250	1.250	6.000	1.500	1.250	1.500				
MTJNR/L-245	MTJNR/L245E	●	●		66 <sup>○</sup> *1	1.500	1.500	7.000	1.500	1.500	2.000				
MTJNR/L-246	MTJNR/L246E	●	□	66 <sup>○</sup> *1	1.500	1.500	7.000	1.625	1.500	2.000					

\*1 (Opt.) See page M012 for different thickness or radius.  
 \*2 Clamp Torque (lbf-in) : XNS36=30, XNS510=70

DTGN

**External turning DOUBLE CLAMP Type**

Right hand tool holder shown.

Finish	Light	Medium	Medium
FP  (3)	LP  (3)	MP  (3,4)	MK  (3)
Medium to Rough	Stainless	G Class	CBN
RP  (3,4)	MM  (3,4)	R/L  (3,4)	 (3)

Order Number	ANSI Number	Stock		Insert Number	Dimensions (inch)						Shim	Shim Pin	Clamp Bridge	Spring	Clamp Screw	Wrench	
		R	L		H	B	LF	LH	HF	WF							
DTGNR/L-123	DTGNR/L123B	●	●	TNMA TNMG TNMM TNGA TNGG	33 <sup>○</sup>	.750	.750	4.500	1.000	.750	1.000	LLSTN32 <sup>*1</sup> (LLSTN33)	LLP23	DCK2211	DCS2	DC0520T	TKY15F
DTGNR/L-163	DTGNR/L163D	●	●		43 <sup>○</sup>	1.000	1.000	6.000	1.000	1.000	1.250						
DTGNR/L-164	DTGNR/L164D	●	●		43 <sup>○</sup>	1.000	1.000	6.000	1.250	1.000	1.250	LLSTN42	LLP14	DCK2613	DCS1	DC0621T	TKY20F
DTGNR/L-204	DTGNR/L204D	●	●		43 <sup>○</sup>	1.250	1.250	6.000	1.250	1.250	1.500						
DTGNR/L-244	DTGNR/L244D	●	●		43 <sup>○</sup>	1.500	1.500	6.000	1.250	1.500	2.000						

\*1 Please use shim no.LLSTN33 with .125inch thick insert. When using .125inch thick inserts, the shim must be ordered separately.  
 \*2 Clamp Torque (lbf-in) : DC0520T=31, DC0621T=44

Note 1) Insert photo is an example. Letters show chip breaker style, figures show inscribed circle.

● : USA Stock    □ : Made to Order

MTJN type inserts > A130-A137  
 DTGN type inserts > A130-A137

CBN & PCD inserts > B030, B031, B050  
 CUTTING CONDITIONS > A080, B008

# MTGN

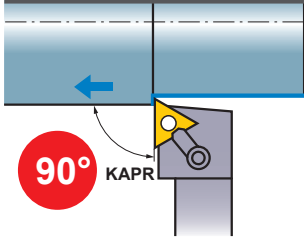

## External turning Multiple Clamp Type M Holder

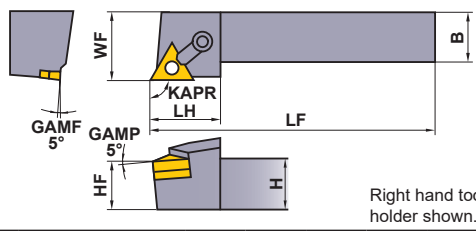

Finish	Light	Medium	Medium
FP (3)	LP (3)	MP (3,4)	MK (3,4)
Medium to Rough RP (3)	Stainless MM (3,4)	G Class R/L (3,4)	CBN (3)

Order Number	ANSI Number	Stock		Insert Number	Dimensions (inch)						Shim	Shim Pin	Clamp Bridge	Clamp Screw <sup>*3</sup>	
		R	L		H	B	LF	LH	HF	WF					
MTGNR/L-123BX	MTGNR/L123B	●	●	TNMA TNMG TNMM TNGA TNGG	33 <sup>*1*2</sup>	.750	.750	4.500	1.000	.750	1.000	ITSN322 <sup>*1</sup>	NL34L	CL6	XNS36
MTGNR/L-163CX	MTGNR/L163C	●	●			1.000	1.000	5.000	1.000	1.000	1.250				
MTGNR/L-163DX	MTGNR/L163D	□	●			1.000	1.000	6.000	1.000	1.000	1.250				
MTGNR/L-164C	MTGNR/L164C	●	●		43 <sup>*1</sup>	1.000	1.000	5.000	1.375	1.000	1.250	ITSN433 <sup>*1</sup>	NL46	CL9	XNS510
MTGNR/L-164D	MTGNR/L164D	●	●			1.000	1.000	6.000	1.375	1.000	1.250				
MTGNR/L-204D	MTGNR/L204D	□	●		54 <sup>*1</sup>	1.250	1.250	6.000	1.375	1.250	1.500	ITSN533 <sup>*1</sup>	NL58	CL9	XNS510
MTGNR/L-244D	MTGNR/L244D	●	●			1.500	1.500	6.000	1.375	1.500	2.000				
MTGNR/L-244E	MTGNR/L244E	●	●			1.500	1.500	7.000	1.375	1.500	2.000				
MTGNR/L-854D	MTGNR/L854D	●	●		63 <sup>*1</sup>	1.250	1.000	6.000	1.375	1.250	1.250	ITSN636 <sup>*1</sup>	NL68L	CL12	XNS510
MTGNR/L-165C	MTGNR/L165C	□	□			1.000	1.000	5.000	1.500	1.000	1.250				
MTGNR/L-165D	MTGNR/L165D	●	●		1.000	1.000	6.000	1.500	1.000	1.250					
MTGNR/L-205D	MTGNR/L205D	●	□		1.250	1.250	6.000	1.500	1.250	1.500					
MTGNR/L-245D	MTGNR/L245D	□	●		1.500	1.500	6.000	1.375	1.500	2.000					
MTGNR/L-245E	MTGNR/L245E	□	●		1.500	1.500	7.000	1.500	1.500	2.000					
MTGNR-855D	MTGNR855D	●	●		1.250	1.000	6.000	1.500	1.250	1.250					
MTGNR/L-246D	MTGNR/L246D	●	●		1.500	1.500	6.000	1.500	1.500	2.000					
MTGNR/L-246E	MTGNR/L246E	●	●	1.500	1.500	7.000	1.750	1.500	2.000						

\*1 (Opt.) See page M012 for different thickness or radius.  
 \*3 Clamp Torque (lbf-in) : XNS36=30, XNS510=70

\*2 For inserts without hole, remove shim pin and add below.

Shim Screw	Chipbreaker
S34	CBT3

EXTERNAL TURNING TOOLS

# EXTERNAL TURNING TOOLS

## TN INSERTS TOOL HOLDERS

### MTAN

**External turning Multiple Clamp Type M Holder**

Right hand tool holder shown.

Finish	Light	Medium	Medium
FP  (3)	LP  (3)	MP  (3,4)	MK  (3,4)
Medium to Rough	Stainless	G Class	CBN
RP  (3)	MM  (3,4)	R/L  (3,4)	 (3)

EXTERNAL TURNING TOOLS

Order Number	ANSI Number	Stock		Insert Number	Dimensions (inch)						Shim	Shim Pin	Clamp Bridge	Clamp Screw	
		R	L		H	B	LF	LH	HF	WF					
MTANR-102	MTANR102B	●		TNMA TNMG TNMM TNGA TNGG	22 <sup>○</sup>	.625	.625	4.500	.875	.625	.625	—	NL23	CL19	XNS36
MTANR/L-103X	MTANR/L103B	●	□		33 <sup>○</sup> <sup>*1*2</sup>	.625	.625	4.500	1.000	.625	.625	ITSN323 <sup>*1</sup>	NL34L	CL6	XNS36
MTANR/L-123X	MTANR/L123B	●	□			.750	.750	4.500	1.000	.750	.750				
MTANR/L-163X	MTANR/L163D	●	●		43 <sup>○</sup> <sup>*1</sup>	1.000	1.000	6.000	1.000	1.000	1.000	ITSN433 <sup>*1</sup>	NL46	CL9	XNS59
MTANR/L-164	MTANR/L164D	●	●			1.000	1.000	6.000	1.375	1.000	1.000				
MTANR/L-204	MTANR/L204E	●	●		54 <sup>○</sup> <sup>*1</sup>	1.250	1.250	7.000	1.375	1.250	1.250	ITSN533 <sup>*1</sup>	NL58	CL9	XNS510
MTANR-864	MTANR864E	□				1.500	1.000	7.000	1.375	1.500	1.000				
MTANR-165	MTANR165D	●			66 <sup>○</sup> <sup>*1</sup>	1.000	1.000	6.000	1.500	1.000	1.000	ITSN636 <sup>*1</sup>	NL68L	CL12	XNS510
MTANR-205	MTANR205E	●				1.250	1.250	7.000	1.500	1.250	1.250				
MTANR-246	MTANR246E	●				1.500	1.500	7.000	1.750	1.500	1.500				

\*1 (Opt.) See page M012 for different thickness or radius. \*2 For inserts without hole, remove shim pin and add below. \*3 Clamp Torque (lbf-in) : XNS36=30, XNS59=70, XNS510=70

Shim Screw	Chipbreaker
S34	CBT3

### MTRN

**External turning Multiple Clamp Type M Holder**

Right hand tool holder shown.

Finish	Light	Medium	Medium
FP  (3)	LP  (3)	MP  (3,4)	MK  (3,4)
Medium to Rough	Stainless	G Class	CBN
RP  (3)	MM  (3,4)	R/L  (3,4)	 (3)

Order Number	ANSI Number	Stock		Insert Number	Dimensions (inch)						Shim	Shim Pin	Clamp Bridge	Clamp Screw	
		R	L		H	B	LF	LH	HF	WF					
MTRNR/L-123X	MTRNR/L123B	□	□	TNMA TNMG TNMM TNGA TNGG	33 <sup>○</sup> <sup>*1*2</sup>	.750	.750	4.500	1.250	.750	.855	ITSN323 <sup>*1</sup>	NL34L	CL20	XNS47
MTRNR/L-164	MTRNR/L164D	●	□		43 <sup>○</sup> <sup>*1</sup>	1.000	1.000	6.000	1.375	1.000	1.048	ITSN433 <sup>*1</sup>	NL46	CL9	XNS510

\*1 (Opt.) See page M012 for different thickness or radius. \*2 For inserts without hole, remove shim pin and add below. \*3 Clamp Torque (lbf-in) : XNS47=45, XNS510=70

Shim Screw	Chipbreaker
S34	CBT3

Note 1) Insert photo is an example. Letters show chip breaker style, figures show inscribed circle.

● : USA Stock □ : Made to Order





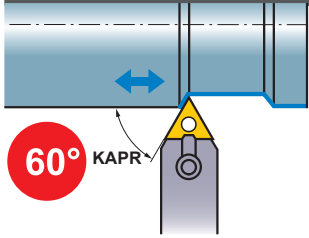

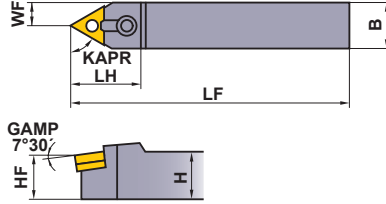

MTAN type inserts > A130-A137  
 MTRN type inserts > A130-A137  
 CBN & PCD inserts > B030, B031, B050  
 CUTTING CONDITIONS > A080, B008

# MTEN



## External turning Chamfering Multiple Clamp Type M Holder



Finish	Light	Medium	Medium
FP  (3)	LP  (3)	MP  (3,4)	MK  (3,4)
Medium to Rough RP  (3)	Stainless MM  (3,4)	G Class R/L  (3,4)	CBN  (3)

Order Number	ANSI Number	Stock	Insert Number	Dimensions (inch)						Shim	Shim Pin	Clamp Bridge	Clamp Screw <sup>*2</sup>	
				H	B	LF	LH	HF	WF					
MTENN-82	MTENN082B	●	TNMA TNMG TNMM TNGA TNGG	22 <sup>○</sup>	.500	.500	4.500	1.000	.500	.250	—	NL23	CL6	XNS36
MTENN-103X	MTENN103B	●		33 <sup>○</sup> *1	.625	.625	4.500	1.125	.625	.313	ITSN323 <sup>*1</sup>	NL34L	CL6	XNS36
MTENN-123X	MTENN123B	●		33 <sup>○</sup> *1	.750	.750	4.500	1.125	.750	.375	ITSN323 <sup>*1</sup>	NL34L	CL6	XNS36
MTENN-164	MTENN164D	●		43 <sup>○</sup> *1	1.000	1.000	6.000	1.500	1.000	.500	ITSN433 <sup>*1</sup>	NL46	CL9	XNS59
MTENN-854	MTENN854D	□		43 <sup>○</sup> *1	1.250	1.000	6.000	1.500	1.250	.500	ITSN433 <sup>*1</sup>	NL46	CL9	XNS59
MTENN-864	MTENN864E	●		43 <sup>○</sup> *1	1.500	1.000	7.000	1.500	1.500	.500	ITSN433 <sup>*1</sup>	NL46	CL9	XNS59
MTENN-205	MTENN205E	●		54 <sup>○</sup> *1	1.250	1.250	7.000	1.625	1.250	.625	ITSN533 <sup>*1</sup>	NL58	CL9	XNS510
MTENN-865	MTENN865E	●		54 <sup>○</sup> *1	1.500	1.000	7.000	1.625	1.500	.500	ITSN533 <sup>*1</sup>	NL58	CL9	XNS510

\*1 (Opt.) See page M012 for different thickness or radius.





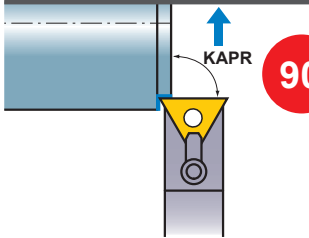

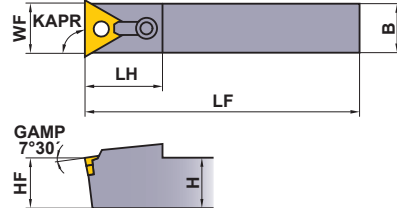

\*2 Clamp Torque (lbf-in) : XNS36=30, XNS59=70, XNS510=70

# MTCN



## Facing Multiple Clamp Type M Holder



Finish	Light	Medium	Medium
FP  (3)	LP  (3)	MP  (3,4)	MK  (3,4)
Medium to Rough RP  (3)	Stainless MM  (3,4)	G Class R/L  (3,4)	CBN  (3)

Order Number	ANSI Number	Stock	Insert Number	Dimensions (inch)						Shim	Shim Pin	Clamp Bridge	Clamp Screw <sup>*3</sup>	
				H	B	LF	LH	HF	WF					
MTCNN-83X	MTCNN083B	□	TNMA TNMG TNMM TNGA TNGG	33 <sup>○</sup> *1*2	.500	.500	4.500	1.000	.500	Central to "B"	ITSN323 <sup>*1</sup>	NL34L	CL7	XNS36
MTCNN-443X	MTCNN443F	□		33 <sup>○</sup> *1*2	1.000	.500	8.000	1.000	1.000		ITSN323 <sup>*1</sup>	NL34L	CL7	XNS36
MTCNN-124	MTCNN124B	●		43 <sup>○</sup> *1	.750	.750	4.500	1.375	.750		ITSN433 <sup>*1</sup>	NL46	CL12	XNS59
MTCNN-644	MTCNN644F	□		43 <sup>○</sup> *1	1.000	.750	8.000	1.375	1.000		ITSN433 <sup>*1</sup>	NL46	CL12	XNS59
MTCNN-664	MTCNN664F	□		43 <sup>○</sup> *1	1.500	.750	8.000	1.375	1.500		ITSN433 <sup>*1</sup>	NL46	CL12	XNS59

\*1 (Opt.) See page M012 for different thickness or radius.

\*3 Clamp Torque (lbf-in) : XNS36=30, XNS59=70

\*2 For inserts without hole, remove shim pin and add below.

Shim Screw	S34	Chipbreaker	CBT3
------------	-----	-------------	------

MTEN type inserts > A130-A137  
MTCN type inserts > A130-A137  
CBN & PCD inserts > B030, B031, B050  
CUTTING CONDITIONS > A080, B008

SPARE PARTS > M001  
TECHNICAL DATA > N001

# EXTERNAL TURNING TOOLS

## TN INSERTS TOOL HOLDERS

EXTERNAL TURNING TOOLS

DTFNR

**DOUBLE CLAMP Type**

Facing

Right hand tool holder shown.

Finish
FP  (3)
Medium to Rough RP  (3)

Light
LP  (3)
Stainless MM  (3,4)

Medium
MP  (3,4)
G Class R/L  (3,4)

Medium
MK  (3,4)
CBN  (3)

Order Number	ANSI Number	Stock		Insert Number	Dimensions (inch)						Shim	Shim Pin	Clamp Bridge	Spring	Clamp Screw	Wrench
		R	L		H	B	LF	LH	HF	WF						
DTFNR/L-123	DTFNR/L123B	●	●	33	.750	.750	4.500	1.000	.750	1.000	*1 LLSTN32 (LLSTN33)	LLP23	DCK2211	DCS2	DC0520T	TKY15F
DTFNR/L-163	DTFNR/L163D	●	●		1.000	1.000	6.000	1.000	1.000	1.250						
DTFNR/L-164	DTFNR/L164D	●	●	43	1.000	1.000	6.000	1.219	1.000	1.250	LLSTN42	LLP14	DCK2613	DCS1	DC0621T	TKY20F
DTFNR/L-204	DTFNR/L204D	●	●		1.250	1.250	6.000	1.219	1.250	1.500						

\*1 Please use shim no.LLSTN33 with .125inch thick insert. When using .125inch thick inserts, the shim must be ordered separately.  
 \*2 Clamp Torque (lbf-in) : DC0520T=31, DC0621T=44

DTCNR

**DOUBLE CLAMP Type**

Facing

Finish
FP  (3)
Medium to Rough RP  (3)

Light
LP  (3)
Stainless MM  (3)

Medium
MP  (3)
G Class R/L  (3)

Medium
MK  (3)
CBN  (3)

Order Number	ANSI Number	Stock		Insert Number	Dimensions (inch)						Shim	Shim Pin	Clamp Bridge	Spring	Clamp Screw	Wrench
		R	L		H	B	LF	LH	HF	WF						
DTCNN-433	DTCNN433B	●	●	33	.750	.500	4.500	1.375	.750	.539	*1 LLSTN32 (LLSTN33)	LLP23	DCK3113	DCS2	DC0520T	TKY15F
DTCNN-443	DTCNN443D	●	●		1.000	.500	6.000	1.375	1.000	.539						

\*1 Please use shim no.LLSTN33 with .125inch thick insert. When using .125inch thick inserts, the shim must be ordered separately.  
 \*2 Clamp Torque (lbf-in) : DC0520T=31

Note 1) Insert photo is an example. Letters show chip breaker style, figures show inscribed circle.

● : USA Stock    □ : Made to Order

DTFN type inserts > A130-A137  
 DTCN type inserts > A130-A137

CBN & PCD inserts > B030, B031, B050  
 CUTTING CONDITIONS > A080, B008



# MTFN

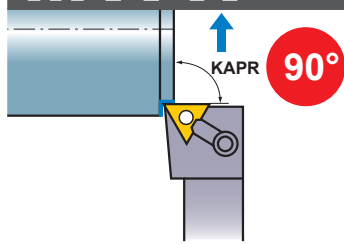





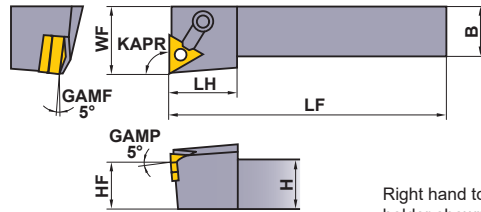



Facing

Multiple Clamp Type  
M Holder



Right hand tool holder shown.

Finish	Light	Medium	Medium
FP  (3)	LP  (3)	MP  (3,4)	MK  (3,4)
Medium to Rough RP  (3)	Stainless MM  (3,4)	G Class R/L  (3,4)	CBN  (3)

Order Number	ANSI Number	Stock		Insert Number	Dimensions (inch)						Shim	Shim Pin	Clamp Bridge	Clamp Screw <sup>*3</sup>	
		R	L		H	B	LF	LH	HF	WF					
MTFNR/L-82	MTFNR/L082B	<input type="checkbox"/>	<input type="checkbox"/>	TNMA TNMG TNMM TNGA TNGG	22	.500	.500	4.500	.875	.500	.750	—	NL23	CL19	XNS36
MTFNR/L-103X	MTFNR/L103B	<input type="checkbox"/>	<input type="checkbox"/>		33 <sup>*1*2</sup>	.625	.625	4.500	1.000	.625	.875	ITSN323 <sup>*1</sup>	NL34L	CL6	XNS36
MTFNR/L-123BX	MTFNR/L123B	<input checked="" type="checkbox"/>	<input checked="" type="checkbox"/>		33 <sup>*1*2</sup>	.750	.750	4.500	1.000	.750	1.000				
MTFNR/L-163CX	MTFNR/L163C	<input checked="" type="checkbox"/>	<input checked="" type="checkbox"/>			1.000	1.000	5.000	1.000	1.000	1.250				
MTFNR/L-163DX	MTFNR/L163D	<input type="checkbox"/>	<input type="checkbox"/>		43 <sup>*1</sup>	1.000	1.000	6.000	1.000	1.000	1.250	ITSN433 <sup>*1</sup>	NL46	CL9	XNS510
MTFNR/L-164C	MTFNR/L164C	<input checked="" type="checkbox"/>	<input checked="" type="checkbox"/>			1.000	1.000	5.000	1.250	1.000	1.250				
MTFNR/L-164D	MTFNR/L164D	<input checked="" type="checkbox"/>	<input checked="" type="checkbox"/>		54 <sup>*1</sup>	1.000	1.000	6.000	1.250	1.000	1.250	ITSN533 <sup>*1</sup>	NL58	CL12	XNS510
MTFNR/L-204D	MTFNR/L204D	<input checked="" type="checkbox"/>	<input checked="" type="checkbox"/>			1.250	1.250	6.000	1.250	1.250	1.500				
MTFNL-165C	MTFNL165C	<input checked="" type="checkbox"/>	<input checked="" type="checkbox"/>		66 <sup>*1</sup>	1.000	1.000	5.000	1.375	1.000	1.250	ITSN636 <sup>*1</sup>	NL68L	CL12	XNS510
MTFNR/L-165D	MTFNR/L165D	<input checked="" type="checkbox"/>	<input checked="" type="checkbox"/>			1.000	1.000	6.000	1.375	1.000	1.250				
MTFNR/L-205D	MTFNR/L205D	<input checked="" type="checkbox"/>	<input checked="" type="checkbox"/>		66 <sup>*1</sup>	1.250	1.250	6.000	1.375	1.250	1.500	ITSN636 <sup>*1</sup>	NL68L	CL12	XNS510
MTFNR/L-855D	MTFNR/L855D	<input checked="" type="checkbox"/>	<input checked="" type="checkbox"/>			1.250	1.000	6.000	1.375	1.250	1.250				
MTFNR/L-246D	MTFNR/L246D	<input checked="" type="checkbox"/>	<input checked="" type="checkbox"/>		66 <sup>*1</sup>	1.500	1.500	6.000	1.500	1.500	2.000	ITSN636 <sup>*1</sup>	NL68L	CL12	XNS510
MTFNR/L-246E	MTFNR/L246E	<input checked="" type="checkbox"/>	<input checked="" type="checkbox"/>	1.500		1.500	7.000	1.500	1.500	2.000					

\*1 (Opt.) See page M012 for different thickness or radius.

\*3 Clamp Torque (lbf-in) : XNS36=30, XNS510=70

\*2 For inserts without hole, remove shim pin and add below.

Shim Screw	Chipbreaker
S34	CBT3

EXTERNAL TURNING TOOLS

MTFN type inserts > A130-A137  
 CBN & PCD inserts > B030, B031, B050  
 CUTTING CONDITIONS > A080, B008

SPARE PARTS > M001  
 TECHNICAL DATA > N001

# EXTERNAL TURNING TOOLS

## VN INSERTS TOOL HOLDERS



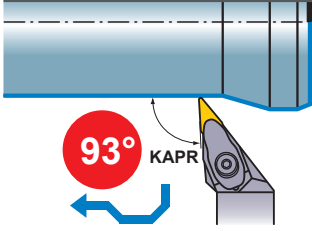



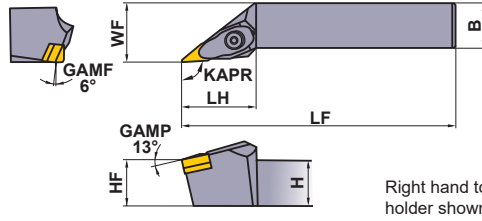

### DVJN



External turning **DOUBLE CLAMP Type**  
Copying



Right hand tool holder shown.

Finish	Light	Medium	Medium
FP	LP	MP	MK
 (3)	 (3)	 (3)	 (3)
Medium	Stainless	G Class	CBN
Standard	MM	R/L	
 (3)	 (3)	 (3)	 (3)

Order Number	ANSI Number	Stock		Insert Number	Dimensions (inch)						Shim	Shim Pin	Clamp Bridge	Spring	Clamp Screw	* Wrench	
		R	L		H	B	LF	LH	HF	WF							
DVJNR/L-123	DVJNR/L123B	●	●	VNGA VNMG	.750	.750	4.500	1.625	.750	1.000							
DVJNR/L-163	DVJNR/L163D	●	●	VNGM	1.000	1.000	6.000	1.625	1.000	1.250	DCSVN32	LLP13	DCK3113	DCS2	DC0520T	TKY15F	
DVJNR/L-203	DVJNR/L203D	●	●	VNGG VNMM	1.250	1.250	6.000	1.625	1.250	1.500							

\* Clamp Torque (lbf-in) : DC0520T=31

EXTERNAL TURNING TOOLS



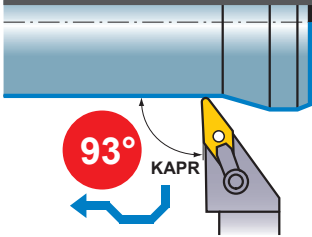



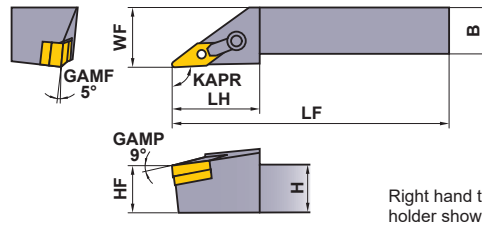

### MVJN



External turning **Multiple Clamp Type**  
Copying M Holder

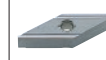

Right hand tool holder shown.

Finish	Light	Medium	Medium
FP	LP	MP	MK
 (3)	 (3)	 (3)	 (3)
Medium	Stainless	G Class	CBN
Standard	MM	R/L	
 (3)	 (3)	 (3)	 (3)

Order Number	ANSI Number	Stock		Insert Number	Dimensions (inch)						Shim	Shim Pin	Clamp Bridge	*2 Clamp Screw
		R	L		H	B	LF	LH	HF	WF				
MVJNR/L-123B	MVJNR/L123B	●	●	VNGA VNMG VNGM VNGG VNMM	.750	.750	4.500	1.750	.750	1.000	IVSN322	NL34L	CL30	XNS510
MVJNR/L-163C	MVJNR/L163C	●	●		1.000	1.000	5.000	1.750	1.000	1.250				
MVJNR/L-163D	MVJNR/L163D	●	●		1.000	1.000	6.000	1.750	1.000	1.250				
MVJNR/L-203D	MVJNR/L203D	□	□		1.250	1.250	6.000	1.750	1.250	1.500				
MVJNR/L-164C	MVJNR/L164C	□	●	43	1.000	1.000	5.000	2.125	1.000	1.250	IVSN433 <sup>*1</sup>	NL46	CL30	XNS510
MVJNR/L-164D	MVJNR/L164D	●	●		1.000	1.000	6.000	2.125	1.000	1.250				
MVJNR/L-204D	MVJNR/L204D	□	□		1.250	1.250	6.000	2.125	1.250	1.500				

\*1 (Opt.) See page M012 for different radius.

\*2 Clamp Torque (lbf-in) : XNS510=70

Note 1) Insert photo is an example. Letters show chip breaker style, figures show inscribed circle.

● : USA Stock    □ : Made to Order

DVJN type inserts > A138-A141  
MVJN type inserts > A138-A141

CBN & PCD inserts > B032, B033, B051  
CUTTING CONDITIONS > A080, B008

DVPN		Facing Copying		DOUBLE CLAMP Type							Finish		Light	Medium	Medium
											FP	LP	MP	MK	
											 (3)	 (3)	 (3)	 (3)	
											Medium Standard	Stainless MM	G Class R/L	CBN	
Order Number	ANSI Number	Stock	Insert Number	Dimensions (inch)						Shim	Shim Pin	Clamp Bridge	Spring	Clamp Screw *	Wrench
		R L		H	B	LF	LH	HF	WF						
DVPCR/L-123	DVPCR/L123B	● ●	33	.750	.750	4.500	1.250	.750	1.000	DCSVN32	LLP13	DCK3113	DCS2	DC0520T	TKY15F
DVPCR/L-163	DVPCR/L163D	● ●		1.000	1.000	6.000	1.250	1.000	1.250						

\* Clamp Torque (lbf-in) : DC0520T=31

DVVN		External turning Copying		DOUBLE CLAMP Type							Finish		Light	Medium	Medium
											FP	LP	MP	MK	
											 (3)	 (3)	 (3)	 (3)	
											Medium Standard	Stainless MM	G Class R/L	CBN	
Order Number	ANSI Number	Stock	Insert Number	Dimensions (inch)						Shim	Shim Pin	Clamp Bridge	Spring	Clamp Screw *	Wrench
		R L		H	B	LF	LH	HF	WF						
DVVNN-123	DVVNN123B	● ●	33	.750	.750	4.500	1.750	.750	.375	DCSVN32	LLP13	DCK3113	DCS2	DC0520T	TKY15F
DVVNN-163	DVVNN163D	● ●		1.000	1.000	6.000	1.750	1.000	.500						

\* Clamp Torque (lbf-in) : DC0520T=31

DVPN type inserts > A138-A141  
 DVVN type inserts > A138-A141  
 CBN & PCD inserts > B032, B033, B051

CUTTING CONDITIONS > A080, B008  
 SPARE PARTS > M001  
 TECHNICAL DATA > N001

# EXTERNAL TURNING TOOLS

## VN INSERTS TOOL HOLDERS

### MVLN

**Facing**

Right hand tool holder shown.

**Multiple Clamp Type  
M Holder**

Medium  
MJ

(4)

C

EXTERNAL TURNING TOOLS

Order Number	ANSI Number	Stock		Insert Number	Dimensions (inch)						Shim	Shim Pin	Clamp Bridge	Clamp Screw <sup>*2</sup>
		R	L		H	B	LF	LH	HF	WF				
MVLNR/L-164C	MVLNR/L164C	●	●	VNGM 43	1.000	1.000	5.000	1.500	1.000	1.750	IVSN433 <sup>*1</sup>	NL46	CL30	XNS510
MVLNR/L-164D	MVLNR/L164D	●	●		1.000	1.000	6.000	1.500	1.000	1.750				
MVLNR/L-204D	MVLNR/L204D	●	●		1.250	1.250	6.000	1.500	1.250	2.000				
MVLNR-244D	MVLNR244D	□			1.500	1.500	6.000	1.500	1.500	2.250				

\*1 (Opt.) See page M012 for different radius.  
 \*2 Clamp Torque (lbf-in) : XNS510=70

Note 1) Insert photo is an example. Letters show chip breaker style, figures show inscribed circle.

● : USA Stock    □ : Made to Order

# WN INSERTS TOOL HOLDERS

## DWLN

External turning **DOUBLE CLAMP** Type Facing

Right hand tool holder shown.

Finish	Light	Medium	Medium
FP (4)	LP (4)	MP (3,4)	MK (4)
Medium	Medium to Rough	Stainless	CBN
Standard (4)	RP (4)	MM (3,4)	(4)

Order Number	ANSI Number	Stock		Insert Number	Dimensions (inch)						Shim	Shim Pin	Clamp Bridge	Spring	Clamp Screw	Wrench	
		R	L		H	B	LF	LH	HF	WF							
DWLN/L-123	DWLN/L123B	●	●	WNMA WNMG WNGA	33	.750	.750	4.500	1.000	.750	1.000	LLSWN32 (LLSWN33)	LLP23	DCK2211	DCS2	DC0520T	TKY15F
DWLN/L-163	DWLN/L163D	●	●		43	1.000	1.000	6.000	1.000	1.000	1.250	LLSWN42	LLP14	DCK2613	DCS1	DC0621T	TKY20F
DWLN/L-124	DWLN/L124B	●	●		.750	.750	4.500	1.250	.750	1.000							
DWLN/L-164	DWLN/L164D	●	●		1.000	1.000	6.000	1.250	1.000	1.250							
DWLN/L-204	DWLN/L204D	●	●		1.250	1.250	6.000	1.250	1.250	1.500							

\*1 Please use shim no.LLSWN33 with .125inch thick insert. When using .125inch thick inserts, the shim must be ordered separately.

\*2 Clamp Torque (lbf-in) : DC0520T=31, DC0621T=44

## MWLN

External turning **Multiple Clamp** Type M Holder Facing

Right hand tool holder shown.

Finish	Light	Medium	Medium
FP (4)	LP (4)	MP (3,4)	MK (4)
Medium	Medium to Rough	Stainless	CBN
Standard (4)	RP (4)	MM (3,4)	(4)

Order Number	ANSI Number	Stock		Insert Number	Dimensions (inch)						Shim	Shim Pin	Clamp Bridge	Clamp Screw	
		R	L		H	B	LF	LH	HF	WF					
MWLN/L-1232	MWLN/L1232B	●	●	WNMA WNMG WNGA	33	.750	.750	4.500	1.000	.750	1.000	IWSN322	NL34L	CL6	XNS36
MWLN/L-1632	MWLN/L1632D	●	●		1.000	1.000	6.000	1.000	1.000	1.250					
MWLN/L-1233	MWLN/L1233B	●	●		.750	.750	4.500	1.000	.750	1.000					
MWLN/L-1633	MWLN/L1633D	●	●		1.000	1.000	6.000	1.000	1.000	1.250					
MWLN/L-124B	MWLN/L124B	●	●	43	.750	.750	4.500	1.250	.750	1.000	IWSN433	NL46	CL9	XNS59	
MWLN/L-164D	MWLN/L164D	●	●		1.000	1.000	6.000	1.250	1.000	1.250			CL20	XNS48	
MWLN/L-204D	MWLN/L204D	●	●		1.250	1.250	6.000	1.250	1.250	1.500			CL9	XNS59	
MWLN/L-854D	MWLN/L854D	●	●		1.250	1.000	6.000	1.250	1.250	1.250					
MWLN/L-165D	MWLN/L165D	●	●	54	1.000	1.000	6.000	1.250	1.000	1.250	IWSN533	NL58	CL9	XNS59	
MWLN/L-205D	MWLN/L205D	●	●		1.250	1.250	6.000	1.370	1.250	1.500					
MWLN/L-245E	MWLN/L245E	●	●		1.500	1.500	7.000	1.370	1.500	2.000					

\* Clamp Torque (lbf-in) : XNS36=30, XNS48=45, XNS59=70

DWLN type inserts > A142-A147  
 MWLN type inserts > A142-A147  
 CBN inserts > B034

CUTTING CONDITIONS > A080, B008  
 SPARE PARTS > M001  
 TECHNICAL DATA > N001

EXTERNAL TURNING TOOLS

# EXTERNAL TURNING TOOLS



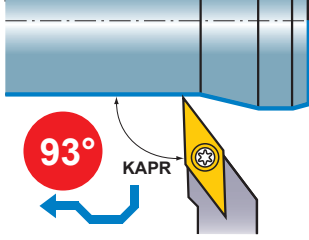

## VB INSERTS TOOL HOLDERS

### SVJB

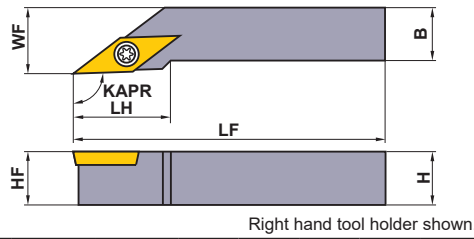

External turning Copying Screw Clamp Type SP Holder

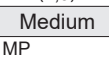
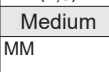
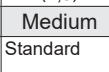
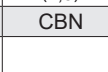

Finish	Finish	Light	Light
FP  (2,3)	FM  (2,3)	LP  (2,3)	LM  (2,3)
Medium MP  (3)	Medium MM  (3)	Medium Standard  (3)	CBN  (2,3)

EXTERNAL TURNING TOOLS

C

Order Number	ANSI Number	Stock		Insert Number	Dimensions (inch)						Clamp Screw	Wrench	
		R	L		H	B	LF	LH	HF	WF			
SVJBR/L-062	SVJBR/L062X	●	●	VBGT VBMT VBET VBGW	22	.375	.375	2.500	.875	.375	.500	TS25	TKY08F
SVJBR/L-082	SVJBR/L082X	●	●			.500	.500	3.500	.875	.500	.625		
SVJBR/L-102	SVJBR/L102A	●	●			.625	.625	4.000	.875	.625	.750		
SVJBR/L-123	SVJBR/L123B	●	●	33	.750	.750	4.500	1.250	.750	1.000	TS4	TKY15F	
SVJBR/L-163	SVJBR/L163D	●	●										1.000





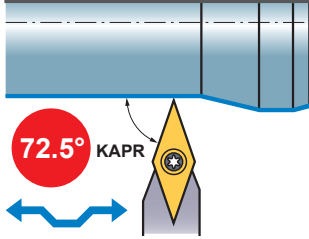

\* Clamp Torque (lbf-in) : TS25=8.9, TS4=31

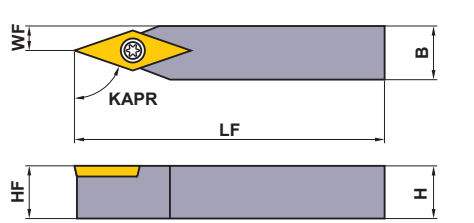
### SVVB



External turning Copying Screw Clamp Type SP Holder

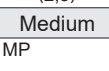
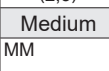
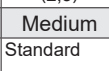

Finish	Finish	Light	Light
FP  (2,3)	FM  (2,3)	LP  (2,3)	LM  (2,3)
Medium MP  (3)	Medium MM  (3)	Medium Standard  (3)	CBN  (2,3)

Order Number	ANSI Number	Stock		Insert Number	Dimensions (inch)						Clamp Screw	Wrench
		R	L		H	B	LF	HF	WF			
SVVBN-062	SVVBN062X	●	●	VBGT VBMT VBET VBGW	22	.375	.375	2.500	.375	.188	TS25	TKY08F
SVVBN-082	SVVBN082X	●	●			.500	.500	3.000	.500	.250		
SVVBN-102	SVVBN102A	●	●			.625	.625	4.000	.625	.313		
SVVBN-122	SVVBN122B	●	●	33	.750	.750	4.500	.750	.375	TS4	TKY15F	
SVVBN-123	SVVBN123B	●	●									.750
SVVBN-163	SVVBN163D	●	●	1.000	1.000	6.000	1.000	.500				

\* Clamp Torque (lbf-in) : TS25=8.9, TS4=31

Note 1) Insert photo is an example. Letters show chip breaker style, figures show inscribed circle.

● : USA Stock

SVJB type inserts > A186-A189  
SVVB type inserts > A186-A189





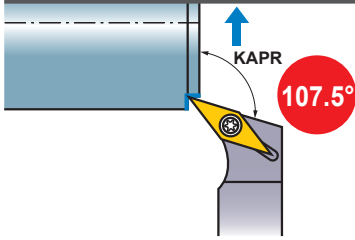

CBN & PCD inserts > B045, B058  
CUTTING CONDITIONS > A093, B008

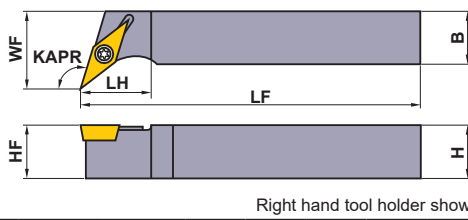
# SVHB



## Facing Screw Clamp Type SP Holder

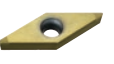

Finish	Finish	Light	Light
FP	FM	LP	LM
 (2,3)	 (2,3)	 (2,3)	 (2,3)
Medium	Medium	Medium	CBN
MP	MM	Standard	
 (3)	 (3)	 (3)	 (2,3)

Order Number	ANSI Number	Stock		Insert Number	Dimensions (inch)						Clamp Screw	Wrench	
		R	L		H	B	LF	LH	HF	WF			
SVHBR/L-062	SVHBR/L062X	●	●	VBGT VBMT VBET VBGW	22	.375	.375	2.500	.875	.375	.500	TS25	TKY08F
SVHBR/L-082	SVHBR/L082X	●	●			.500	.500	3.500	.875	.500	.625		
SVHBR/L-102	SVHBR/L102A	●	●			.625	.625	4.000	.875	.625	.750		
SVHBR/L-123	SVHBR/L123B	●	●			.750	.750	4.500	1.250	.750	1.000		
SVHBR/L-163	SVHBR/L163D	●	●			33	1.000	1.000	6.000	1.250	1.000		

\* Clamp Torque (lbf-in) : TS25=8.9, TS4=31

EXTERNAL TURNING TOOLS

SVHB type inserts > A186-A189  
 CBN & PCD inserts > B045, B058  
 CUTTING CONDITIONS > A093, B008

SPARE PARTS > M001  
 TECHNICAL DATA > N001

# EXTERNAL TURNING TOOLS

## CC INSERTS TOOL HOLDERS



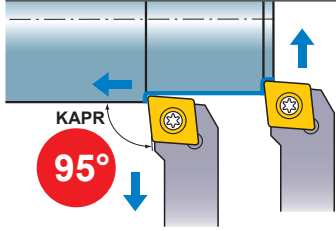



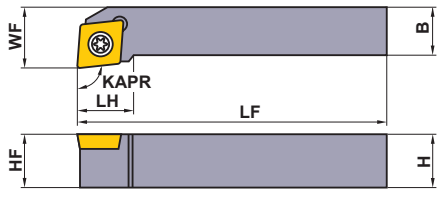

### SCLC



External turning Facing Screw Clamp Type SP Holder



Right hand tool holder shown.

Finish	Light	Medium	Stainless
FP  (2,3)	LP  (2,3)	MP  (2,3)	FM  (2,3)
Stainless LM  (2,3,4)	Stainless MM  (2,3,4)	Flat Top  (2,3,4)	PCD/CBN  (2,3,4)

EXTERNAL TURNING TOOLS

C

Order Number	ANSI Number	Stock		Insert Number	Dimensions (inch)						Shim	Shim Screw	Clamp Screw*	Wrench
		R	L		H	B	LF	LH	HF	WF				
SCLCR/L-062	SCLCR/L062X	●	●	CCGB 21.5	.375	.375	2.500	.350	.375	.500	-	-	TS25	TKY08F
SCLCR/L-083	SCLCR/L083X	●	●	CCET 32.5	.500	.500	3.500	.540	.500	.625			TS43	TKY15F
SCLCR/L-104	SCLCR/L104A	●	●	CCGT 43	.625	.625	4.000	.660	.625	.750			TS5	TKY25F
SCLCR/L-124	SCLCR/L124B	●	●	CCMT 43	.750	.750	4.500	.660	.750	.875	SPSCN42	JSS7	TS53	
SCLCR/L-164	SCLCR/L164D	●	●	CCMW CCGW CCMH	1.000	1.000	6.000	1.000	1.000	1.250				

\* Clamp Torque (lbf-in) : TS25=8.9, TS43=31, TS5=66, TS53=66

Note 1) Insert photo is an example. Letters show chip breaker style, figures show inscribed circle.

● : USA Stock

SCLC type inserts	> A152-A161
CBN & PCD inserts	> B037, B038, B053
CUTTING CONDITIONS	> A093, B008



# DC INSERTS TOOL HOLDERS



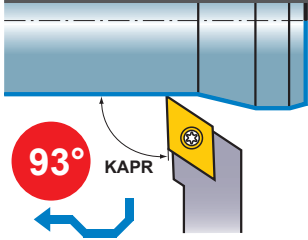

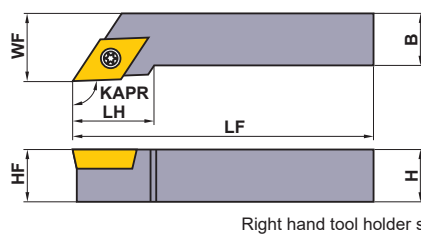

## SDJC



External turning Copying Screw Clamp Type SP Holder

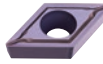

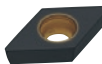
Right hand tool holder shown.

Finish	Light	Medium	Stainless
FP  (2,3)	LP  (2,3)	MP  (2,3)	FM  (2,3)
Stainless	Stainless	Flat Top	PCD/CBN
LM  (2,3)	MM  (2,3)	 (2,3)	 (2,3)

Order Number	ANSI Number	Stock		Insert Number	Dimensions (inch)						Shim	Shim Screw	Clamp Screw *	Wrench	
		R	L		H	B	LF	LH	HF	WF					
SDJCR/L-062	SDJCR/L062X	●	●	21.5	.375	.375	2.500	.500	.375	.500	-	-	TS25	TKY08F	
SDJCR/L-083	SDJCR/L083X	●	●		.500	.500	3.500	.700	.500	.625			TS43	TKY15F	
SDJCR/L-103	SDJCR/L103A	●	●		32.5	.625	.625	4.000	.700	.625	.750	SPSDN32	JSS6	TS406	TKY15R
SDJCR/L-123	SDJCR/L123B	●	●			.750	.750	4.500	.700	.750	.875				
SDJCR/L-163	SDJCR/L163D	●	●			1.000	1.000	6.000	1.000	1.000	1.250				





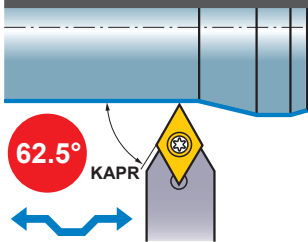

\* Clamp Torque (lbf-in) : TS25=8.9, TS43=31, TS406=31

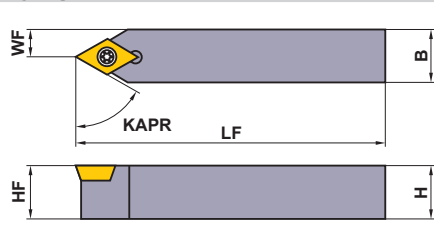
## SDNC

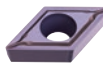

External turning Copying Screw Clamp Type SP Holder

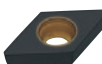

Finish	Light	Medium	Stainless
FP  (2,3)	LP  (2,3)	MP  (2,3)	FM  (2,3)
Stainless	Stainless	Flat Top	PCD/CBN
LM  (2,3)	MM  (2,3)	 (2,3)	 (2,3)

Order Number	ANSI Number	Stock		Insert Number	Dimensions (inch)						Shim	Shim Screw	Clamp Screw *	Wrench
		R	L		H	B	LF	HF	WF					
SDNCN-062	SDNCN062X	●	●	21.5	.375	.375	2.500	.375	.188	-	-	TS25	TKY08F	
SDNCN-083	SDNCN083X	●	●		.500	.500	3.500	.500	.250			TS43	TKY15F	
SDNCN-103	SDNCN103A	●	●		32.5	.625	.625	4.000	.625	.313	SPSDN32	JSS6	TS406	TKY15R
SDNCN-123	SDNCN123B	●	●			.750	.750	4.500	.750	.375				
SDNCN-163	SDNCN163D	●	●			1.000	1.000	6.000	1.000	.500				

\* Clamp Torque (lbf-in) : TS25=8.9, TS43=31, TS406=31

SDJC type inserts > A164-A171  
 SDNC type inserts > A164-A171  
 CBN & PCD inserts > B040, B041, B054

CUTTING CONDITIONS > A093, B008  
 SPARE PARTS > M001  
 TECHNICAL DATA > N001

EXTERNAL TURNING TOOLS

# EXTERNAL TURNING TOOLS

## DC INSERTS TOOL HOLDERS

### SDXC



62.5°

KAPR

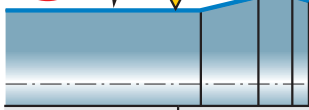





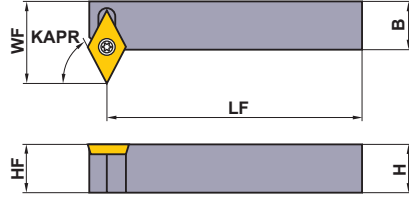



External turning Copying

Screw Clamp Type SP Holder

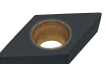

Right hand tool holder shown.

Finish	Light	Medium	Stainless
FP  (2,3)	LP  (2,3)	MP  (2,3)	FM  (2,3)
Stainless	Stainless	Flat Top	PCD/CBN
LM  (2,3)	MM  (2,3)	 (2,3)	 (2,3)

C

EXTERNAL TURNING TOOLS

Order Number	ANSI Number	Stock		Insert Number	Dimensions (inch)					Clamp Screw *	Wrench	
		R	L		H	B	LF	HF	WF			
SDXCR/L-062	SDXCR/L062X	●	●	DCET DCGT DCMT DCMW DCGW	21.5	.375	.375	2.500	.375	.625	TS25	TKY08F
SDXCR/L-082	SDXCR/L082X	●	●			.500	.500	3.500	.500	.750		
SDXCR/L-103	SDXCR/L103A	●	●		32.5	.625	.625	4.000	.625	1.000	TS43	TKY15F

\* Clamp Torque (lbf-in) : TS25=8.9, TS43=31

Note 1) Insert photo is an example. Letters show chip breaker style, figures show inscribed circle.

● : USA Stock

SDXC type inserts	> A164–A171
CBN & PCD inserts	> B040, B041, B054
CUTTING CONDITIONS	> A093, B008

# RC INSERTS TOOL HOLDERS

## SRGC

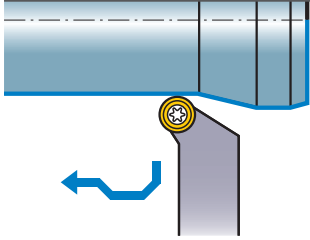

External turning  
Copying

Screw Clamp Type  
SP Holder

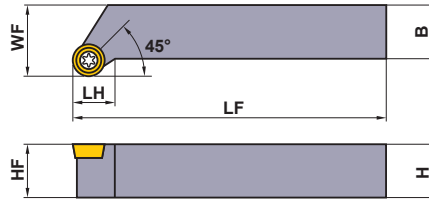

Right hand tool holder shown.

Medium -  
Finish Cutting  
AZ



Medium  
Standard



Order Number	ANSI Number	Stock		Insert Number	Dimensions (inch)						Clamp Screw *	Wrench	
		R	L		H	B	LF	LH	HF	WF			
SRGCR/L-0608M	SRGCR/L0608X	●	●	RCGT RCMT	0803M0	.375	.375	2.500	.610	.375	.625	TS3	TKY08F
SRGCR/L-0808M	SRGCR/L0808X	●	●			.500	.500	3.500	.610	.500	.750		
SRGCR/L-1008M	SRGCR/L1008A	●	●			.625	.625	4.000	.610	.625	.875		

\* Clamp Torque (lbf-in) : TS3=8.9

## SRDC

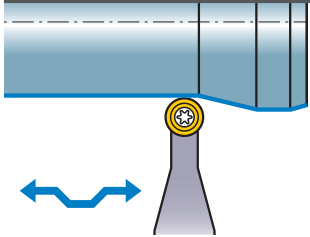

External turning  
Copying

Screw Clamp Type  
SP Holder

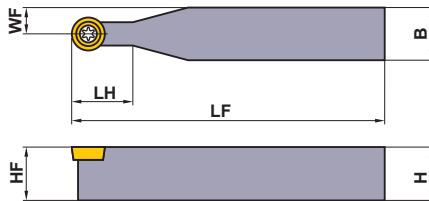

Medium -  
Finish Cutting  
AZ



Medium  
Standard



Order Number	ANSI Number	Stock		Insert Number	Dimensions (inch)						Clamp Screw *	Wrench	
		R	L		H	B	LF	LH	HF	WF			
SRDCN-0608M	SRDCN0608X	●	●	RCGT RCMT	0803M0	.375	.375	2.500	.375	.375	.188	TS3	TKY08F
SRDCN-0808M	SRDCN0808X	●	●			.500	.500	3.500	.500	.500	.250		
SRDCN-1008M	SRDCN1008A	●	●			.625	.625	4.000	.500	.625	.313		

\* Clamp Torque (lbf-in) : TS3=8.9

SRGC type inserts > A173  
SRDC type inserts > A173  
CUTTING CONDITIONS > A093

SPARE PARTS > M001  
TECHNICAL DATA > N001



EXTERNAL TURNING TOOLS

# EXTERNAL TURNING TOOLS





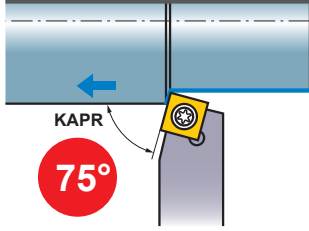

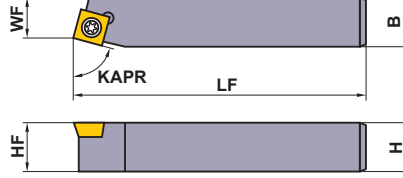

## SC INSERTS TOOL HOLDERS

### SSBC



#### External turning Screw Clamp Type SP Holder



Finish	Light	Medium	Stainless
FP  (3)	LP  (3)	MP  (3)	FM  (3)
Stainless	Stainless	Medium	Flat Top
LM  (3,4)	MM  (3,4)	Standard  (3)	 (3)

Order Number	ANSI Number	Stock		Insert Number	Dimensions (inch)					Shim	Shim Screw	Clamp Screw *	Wrench	
		R	L		H	B	LF	HF	WF					
SSBCR/L-103	SSBCR/L103A	●	●	SCMT SCMW	32.5	.625	.625	4.000	.625	.500	—	—	TS43	TKY15F
SSBCR/L-124	SSBCR/L124B	●	●		43	.750	.750	4.500	.750	.625	SPSSN42	JSS7	TS53	TKY25R
SSBCR/L-164	SSBCR/L164D	●	●		1.000	1.000	6.000	1.000	.875					

\* Clamp Torque (lbf-in) : TS43=31, TS53=66

EXTERNAL TURNING TOOLS





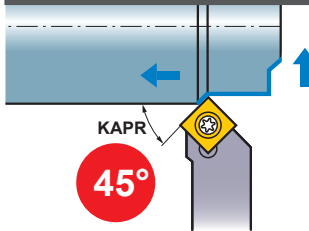

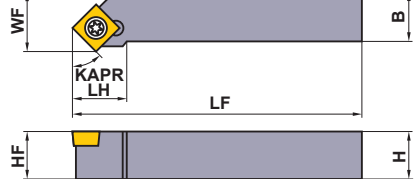

C

### SSSC



#### External turning Facing, Chamfering Screw Clamp Type SP Holder



Finish	Light	Medium	Stainless
FP  (3)	LP  (3)	MP  (3)	FM  (3)
Stainless	Stainless	Medium	Flat Top
LM  (3,4)	MM  (3,4)	Standard  (3)	 (3)

Order Number	ANSI Number	Stock		Insert Number	Dimensions (inch)						Shim	Shim Screw	Clamp Screw *	Wrench	
		R	L		H	B	LF	LH	HF	WF					
SSSCR/L-083	SSSCR/L083X	●	●	SCMT SCMW	32.5	.500	.500	3.500	.625	.500	.550	—	—	TS43	TKY15F
SSSCR/L-103	SSSCR/L103A	●	●		.625	.625	4.000	.625	.625	.680					
SSSCR/L-124	SSSCR/L124B	●	●		43	.750	.750	4.500	1.000	.750	.850	SPSSN42	JSS7	TS53	TKY25R
SSSCR/L-164	SSSCR/L164D	●	●	1.000	1.000	6.000	1.000	1.000	1.110						

\* Clamp Torque (lbf-in) : TS43=31, TS53=66

Note 1) Insert photo is an example. Letters show chip breaker style, figures show inscribed circle.

● : USA Stock

SSBC type inserts > A174, A175  
 SSSC type inserts > A174, A175  
 CUTTING CONDITIONS > A093

# TC INSERTS TOOL HOLDERS

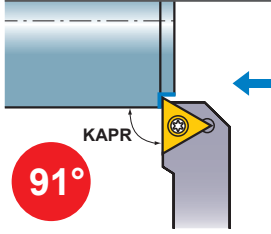

## STGC

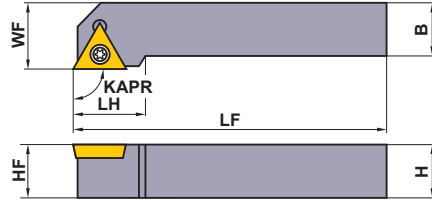

### External turning Screw Clamp Type SP Holder



Right hand tool holder shown.

Finish	Light	Medium	Stainless
FP  (2,3)	LP  (2,3)	MP  (2,3)	FM  (2,3)
Stainless LM  (2,3)	Stainless MM  (2,3)	Flat Top  (2,3)	PCD/CBN  (2,3)

Order Number	ANSI Number	Stock		Insert Number	Dimensions (inch)						Shim	Shim Screw	Clamp Screw *	Wrench	
		R	L		H	B	LF	LH	HF	WF					
STGCR/L-062	STGCR/L062X	●	●	TCGT TCMT TCMW TCGW	21.5	.375	.375	2.500	.550	.375	.500	-	-	TS25	TKY08F
STGCR/L-082.5	STGCR/L082.5X	●	●		2.52	.500	.500	3.500	.700	.500	.625			TS3	
STGCR/L-103	STGCR/L103A	●	●		.625	.625	4.000	.800	.625	.750	TS43			TKY15F	
STGCR/L-123	STGCR/L123B	●	●		32.5	.750	.750	4.500	.800	.750	.875	SPSTN32	JSS6	TS406	TKY15R
STGCR/L-163	STGCR/L163D	●	●			1.000	1.000	6.000	.900	1.000	1.250				

\* Clamp Torque (lbf-in) : TS25=8.9, TS3=8.9, TS43=31, TS406=31



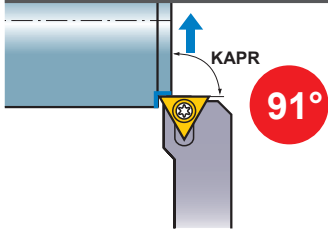

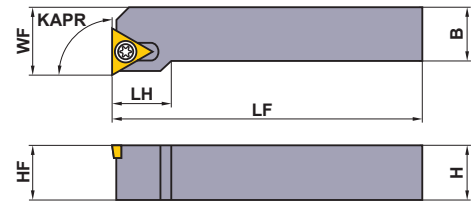

## STFC



### Facing Screw Clamp Type SP Holder



Right hand tool holder shown.

Finish	Light	Medium	Stainless
FP  (2,3)	LP  (2,3)	MP  (2,3)	FM  (2,3)
Stainless LM  (2,3)	Stainless MM  (2,3)	Flat Top  (2,3)	PCD/CBN  (2,3)

Order Number	ANSI Number	Stock		Insert Number	Dimensions (inch)						Shim	Shim Screw	Clamp Screw *	Wrench	
		R	L		H	B	LF	LH	HF	WF					
STFCR/L-062	STFCR/L062X	●	●	TCGT TCMT TCMW TCGW	21.5	.375	.375	2.500	.500	.375	.500	-	-	TS25	TKY08F
STFCR/L-082.5	STFCR/L082.5X	●	●		2.52	.500	.500	3.500	.571	.500	.625			TS3	
STFCR/L-102.5	STFCR/L102.5A	●	●		.625	.625	4.000	.571	.625	.750	TS43			TKY15F	
STFCR/L-123	STFCR/L123B	●	●		32.5	.750	.750	4.500	.866	.750	.875	SPSTN32	JSS6	TS406	TKY15R
STFCR/L-163	STFCR/L163D	●	●			1.000	1.000	6.000	.866	1.000	1.250				

\* Clamp Torque (lbf-in) : TS25=8.9, TS3=8.9, TS406=31

STGC type inserts > A177-A180  
 STFC type inserts > A177-A180  
 CBN & PCD inserts > B042, B055

CUTTING CONDITIONS > A093, B008  
 SPARE PARTS > M001  
 TECHNICAL DATA > N001

EXTERNAL TURNING TOOLS

# EXTERNAL TURNING TOOLS

## VC INSERTS TOOL HOLDERS

### SVPC

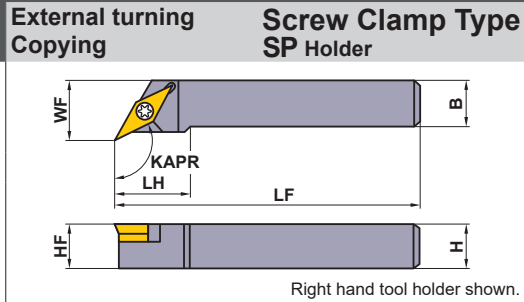
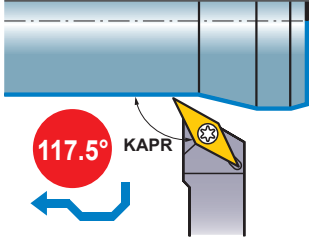

Finish	Light	Medium	Stainless
FP	LP	MP	FM
(2,3)	(2,3)	(2,3)	(2,3)
Stainless	Stainless	Medium	Flat Top
LM	MM	Standard	
(2,3)	(2,3)	(2,3)	(2,3)

EXTERNAL TURNING TOOLS

Order Number	ANSI Number	Stock		Insert Number	Dimensions (inch)						Shim	Shim Pin	Clamp Screw *	Wrench	
		R	L		H	B	LF	LH	HF	WF					
SVPCR/L-082	SVPCR/L082X	●	●	VCMT VCGT	22	.500	.500	3.500	1.000	.500	.750	-	-	TS25	TKY08F
SVPCR/L-102	SVPCR/L102A	●	●			.625	.625	4.000	1.000	.625	.875				
SVPCR/L-123	SVPCR/L123B	●	●	VCMW VCGW	33	.750	.750	4.500	1.206	.750	1.000	SPSVN32	BCP141	TS44	TKY15R
SVPCR/L-163	SVPCR/L163D	●	●			1.000	1.000	6.000	1.206	1.000	1.250				

\* Clamp Torque (lbf-in) : TS25=8.9, TS44=31

### SVJC

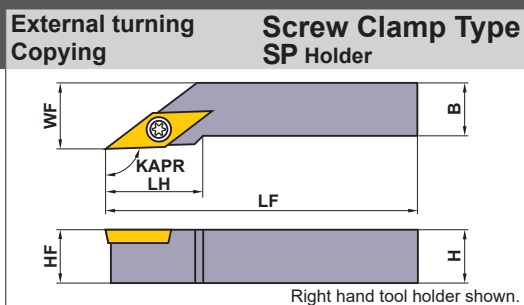
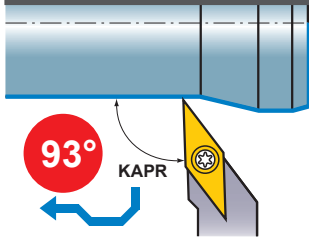

Finish	Light	Medium	Stainless
FP	LP	MP	FM
(2,3)	(2,3)	(2,3)	(2,3)
Stainless	Stainless	Medium	Flat Top
LM	MM	Standard	
(3)	(3)	(2,3)	(2,3)

Order Number	ANSI Number	Stock		Insert Number	Dimensions (inch)						Shim	Shim Pin	Clamp Screw *	Wrench	
		R	L		H	B	LF	LH	HF	WF					
SVJCR/L-062	SVJCR/L062X	●	●	VCMT VCGT	22	.375	.375	2.500	.750	.375	.500	-	-	TS25	TKY08F
SVJCR/L-083	SVJCR/L083X	●	●			.500	.500	3.500	1.000	.500	.625				
SVJCR/L-103	SVJCR/L103A	●	●	VCMW VCGW	33	.625	.625	4.000	1.000	.625	.750	SPSVN32	BCP141	TS43	TKY15F
SVJCR/L-123	SVJCR/L123B	●	●			.750	.750	4.500	1.000	.750	.875				
SVJCR/L-163	SVJCR/L163D	●	●			1.000	1.000	6.000	1.500	1.000	1.250			TS44	TKY15R

\* Clamp Torque (lbf-in) : TS25=8.9, TS43=31, TS44=31

Note 1) Insert photo is an example. Letters show chip breaker style, figures show inscribed circle.

SVPC type inserts	> A190-A192
SVJC type inserts	> A190-A192
CBN & PCD inserts	> B046, B058
CUTTING CONDITIONS	> A093, B008

● : USA Stock

# WC INSERTS TOOL HOLDERS

## SWLC

External turning  
Facing

Screw Clamp Type  
SP Holder

Finish Medium

FJ MJ

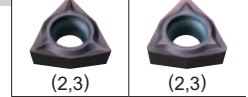

Medium PCD/CBN

Standard

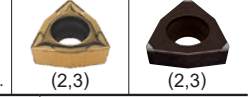

(2,3) (2,3)

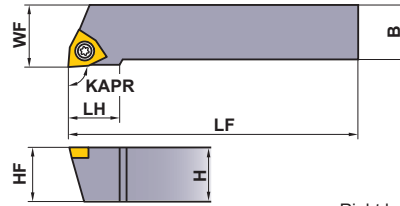
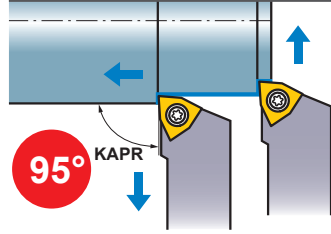

Right hand tool holder shown.

Order Number	ANSI Number	Stock		Insert Number	Dimensions (inch)						Clamp Screw	Wrench	
		R	L		H	B	LF	LH	HF	WF			
SWLCR/L-052	SWLCR/L052X	●	●	WCGT WCMT WCGW	21.5°	.313	.313	2.500	.500	.313	.375	TS25	TKY08F
SWLCR/L-062	SWLCR/L062X	●	●			.375	.375	3.500	.500	.375	.500		
SWLCR/L-082	SWLCR/L082X	●	●			.500	.500	3.500	.500	.500	.625		
SWLCR/L-103	SWLCR/L103A	●	●	32.5°	.625	.625	4.000	.625	.625	.750	TS4	TKY15F	
SWLCR/L-123	SWLCR/L123B	●	●		.750	.750	4.500	.625	.750	1.000			

\* Clamp Torque (lbf-in) : TS25=8.9, TS4=31

EXTERNAL TURNING TOOLS

# EXTERNAL TURNING TOOLS

## XC INSERTS TOOL HOLDERS

### SXZC

External turning Copying

DOUBLE CLAMP Type

Finish SVX

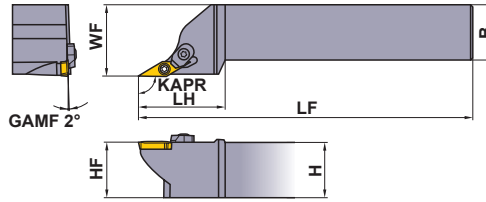
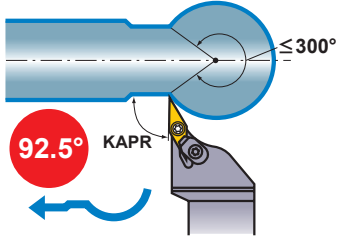

Right hand tool holder shown.



Order Number	ANSI Number	Stock		Insert Number	Dimensions (inch)						* Clamp Screw	Clamp Bridge	* Clamp Bridge Screw	Spring	Wrench (Insert)	Wrench (Clamp Bridge)
		R	L		H	B	LF	LH	HF	WF						
SXZCR/L-102	SXZCR/L102A	●	●	XCMT 22 SVX	.625	.625	4.000	1.378	.625	.750						
SXZCR/L-122	SXZCR/L122B	●	●		.750	.750	4.500	1.378	.750	1.000	TS255	AMS3	AJS3010T10	ASS2	TKY08F	TKY10F
SXZCR/L-162	SXZCR/L162D	●	●		1.000	1.000	6.000	1.575	1.000	1.250						

\* Clamp Torque (lbf-in) : TS255=8.9, AJS3010T10=22

### SXZC

External turning Copying

DOUBLE CLAMP Type

Finish SVX

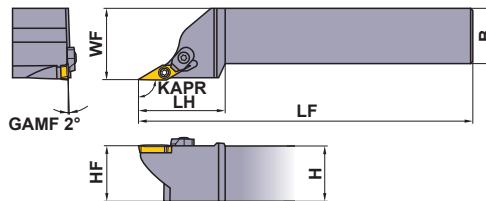
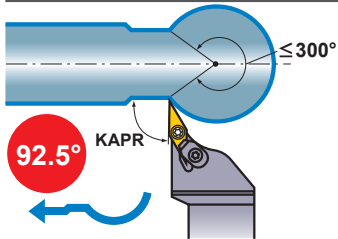

Right hand tool holder shown.



Order Number	ANSI Number	Stock		Insert Number	Dimensions (mm)						* Clamp Screw	Clamp Bridge	* Clamp Bridge Screw	Spring	Wrench (Insert)	Wrench (Clamp Bridge)
		R	L		H	B	LF	LH	HF	WF						
SXZCR/L1616H15	—	●	●	XCMT 22 SVX	16	16	100	35	16	20						
SXZCR/L2020K15	—	●	●		20	20	125	35	20	25	TS255	AMS3	AJS3010T10	ASS2	TKY08F	TKY10F
SXZCR/L2525M15	—	●	●		25	25	150	40	25	32						

\* Clamp Torque (lbf-in) : TS255=8.9, AJS3010T10=22

### APPLICATION RANGE

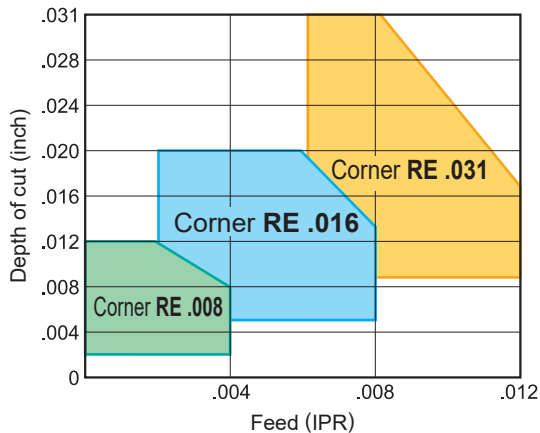

Note 1) Insert photo is an example. Letters show chip breaker style, figures show inscribed circle.

● : USA Stock

### RECOMMENDED CUTTING CONDITIONS

	Work Material	Hardness	Grade	Cutting Speed (SFM)
P	Mild Steel	$\le 180\text{HB}$	MC6125	1115 (785—1310)
	Carbon Steel, Alloy Steel	150HB—250HB	MC6125	720 (525—920)
M	Stainless Steel	$\le 200\text{HB}$	VP15TF	330 (230—395)

Note 1) The above cutting conditions are general guidelines. Adjustments maybe necessary depending on machine rigidity, work material geometry and clamping.



## OPERATIONAL GUIDANCE

### Notes when end face profiling

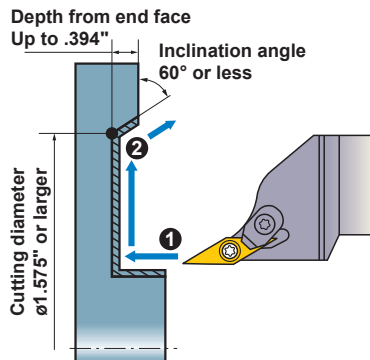

**Pay special attention to the following when face profiling.**

#### Machining of an outer diameter (Step ①)

- To prevent burr formation, the depth of cut should be less than half the corner radius.

#### Machining of an inclination (Step ②)

- To reduce the contact length of chips, the depth of cut should be less than half the corner radius.
- To prevent interference between the tool and the work material, the cutting diameter should be 1.575" or larger, inclination angle 60° or less and depth from the end face up to .394".

#### When changing inserts

- When indexing the inserts, it is recommended to preset the cutting edge position to maintain machining accuracy.

### Not possible

Machining of V-pulleys

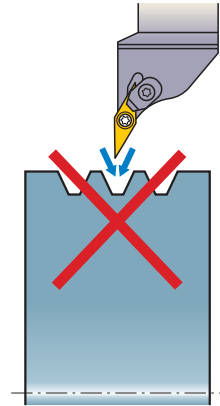

When machining V-pulleys, use a VNMG insert

C

EXTERNAL TURNING TOOLS

# EXTERNAL TURNING TOOLS

## RP INSERTS TOOL HOLDERS

### SRDP

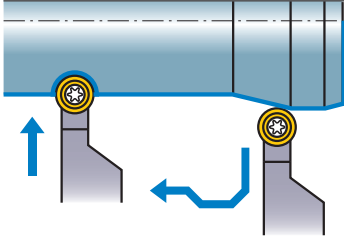

External turning  
Copying

Screw Clamp Type  
SP Holder

Medium  
JS

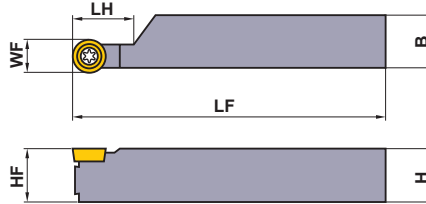

Right hand tool holder shown.

C

EXTERNAL TURNING TOOLS

Order Number	ANSI Number	Stock		Insert Number	Dimensions (inch)						Clamp Screw *	Wrench
		R	L		H	B	LF	LH	HF	WF		
<b>SRDPR/L-1612</b>	<b>SRDPR/L1612D</b>	●	●	RPMT120400E-JS	1.000	1.000	6.000	1.000	1.000	.500	TS43	TKY15F

\* Clamp Torque (lbf-in) : TS43=31

### SRDP

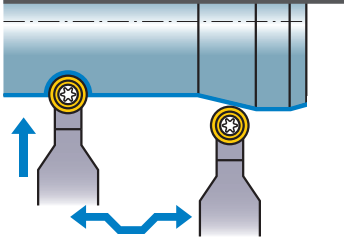

External turning  
Copying

Screw Clamp Type  
SP Holder

Medium  
JS

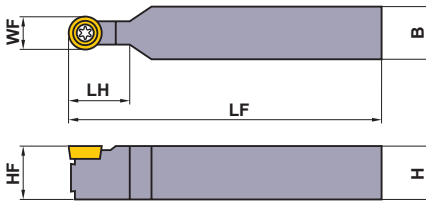

Order Number	ANSI Number	Stock		Insert Number	Dimensions (inch)						Clamp Screw *	Wrench
		R	L		H	B	LF	LH	HF	WF		
<b>SRDPN-1612</b>	<b>SRDPN1612D</b>	●	●	RPMT120400E-JS	1.000	1.000	6.000	1.000	1.000	.500	TS43	TKY15F

\* Clamp Torque (lbf-in) : TS43=31

Note 1) Insert photo is an example. Letters show chip breaker style, figures show inscribed circle.

● : USA Stock

SRDPR/L type inserts > K034  
SRDPN type inserts > K034  
CUTTING CONDITIONS > A102

# DE INSERTS TOOL HOLDERS

## SDJE

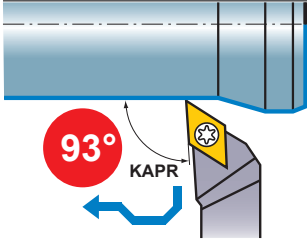

External turning  
Copying

Screw Clamp Type for Aluminum  
AL Holder

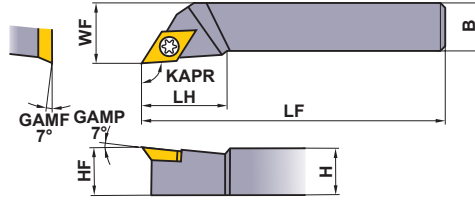

Finish	Medium
R/L-F (4)	R/L (4)
PCD	
R/L-F (4)	

Right hand tool holder shown.

Order Number	ANSI Number	Stock		Insert Number	Dimensions (inch)						Clamp Screw *	Wrench	
		R	L		H	B	LF	LH	HF	WF			
SDJER/L-104	SDJER/L104A	●	●	DEGX 43	.625	.625	4.000	1.000	.625	.750	CS451190T	TKY20F	
SDJER/L-124	SDJER/L124B	●	●		R/L	.750	.750	4.500	1.000	.750			.875
SDJER/L-164	SDJER/L164D	●	●			1.000	1.000	6.000	1.100	1.000			1.250

\* Clamp Torque (lbf-in) : CS451190T=44



EXTERNAL TURNING TOOLS

## RECOMMENDED CUTTING CONDITIONS

Work Material	Grade	Cutting Speed (SFM)	Feed (IPR)	Depth of Cut (inch)
N Aluminum Alloy	HTi10	1310	.002-.012	.008-.118
	MD220	2620	.002-.012	.008-.020

SDJE type inserts > A172  
PCD inserts > B060

SPARE PARTS > M001  
TECHNICAL DATA > N001

C041

# EXTERNAL TURNING TOOLS

## TE INSERTS TOOL HOLDERS

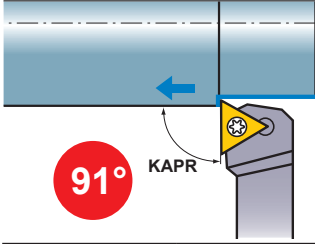

### STGE

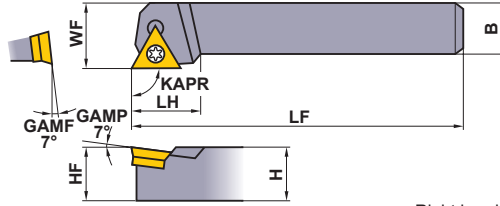

#### External turning Screw Clamp Type for Aluminum AL Holder



Right hand tool holder shown.

Medium	PCD
R/L  (3)	R/L  (3)
PCD  (3)	

C

EXTERNAL TURNING TOOLS

Order Number	ANSI Number	Stock		Insert Number	Dimensions (inch)						Clamp Screw	Wrench
		R	L		H	B	LF	LH	HF	WF		
STGER/L-103	STGER/L103A	●	●	TEGX 32	.625	.625	4.000	.800	.625	.750	FC400890T	TKY10F
STGER/L-123	STGER/L123B	●	●		.750	.750	4.500	.800	.750	.875		
STGER/L-163	STGER/L163D	●	●		1.000	1.000	6.000	.900	1.000	1.250		

Note 1) Right hand tool holder uses right hand insert. Left hand tool holder uses left hand insert.

\* Clamp Torque (lbf-in) : FC400890T=22

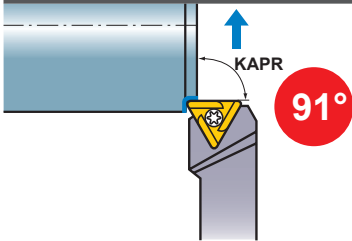

### STFE

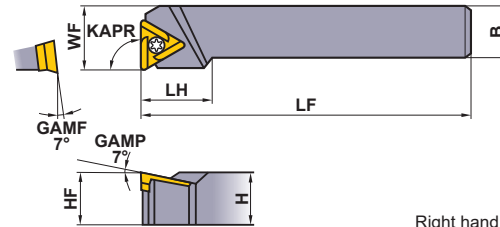

#### Facing Screw Clamp Type for Aluminum AL Holder



Right hand tool holder shown.

Medium	PCD
R/L  (3)	R/L  (3)
PCD  (3)	

Order Number	ANSI Number	Stock		Insert Number	Dimensions (inch)						Clamp Screw	Wrench
		R	L		H	B	LF	LH	HF	WF		
STFER/L-103	STFER/L103A	●	●	TEGX 32	.625	.625	4.000	.866	.625	.750	FC400890T	TKY10F
STFER/L-123	STFER/L123B	●	●		.750	.750	4.500	.866	.750	1.000		
STFER/L-163	STFER/L163D	●	●		1.000	1.000	6.000	.866	1.000	1.250		

Note 1) Right hand tool holder uses left hand insert. Left hand tool holder uses right hand insert.

\* Clamp Torque (lbf-in) : FC400890T=22

Note 1) Insert photo is an example. Letters show chip breaker style, figures show inscribed circle.

● : USA Stock

# VD INSERTS TOOL HOLDERS

## SVPD

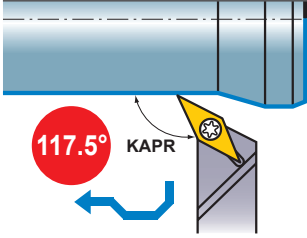

External turning  
Copying

Screw Clamp Type for Aluminum  
AL Holder

Finish  
R/L

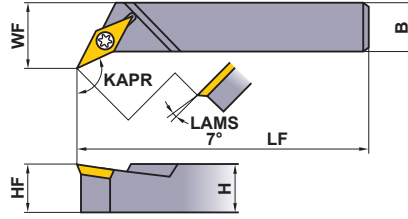

Right hand tool holder shown.

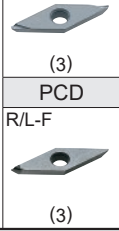

Order Number	ANSI Number	Stock		Insert Number	Dimensions (inch)					Clamp Screw*	Wrench
		R	L		H	B	LF	HF	WF		
SVPDR/L-123	SVPDR/L123B	●	●	VDGX 32 $\circ$ R/L	.750	.750	4.500	.750	1.000	FC400890T	TKY10F
SVPDR/L-163	SVPDR/L163D	●	●		1.000	1.000	6.000	1.000	1.250		

Note 1) Right hand tool holder uses right hand insert. Left hand tool holder uses left hand insert.

\* Clamp Torque (lbf-in) : FC400890T=22

## SVJD

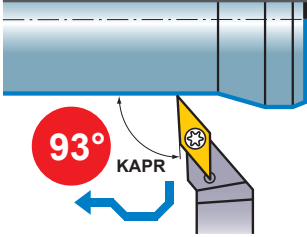

External turning  
Copying

Screw Clamp Type for Aluminum  
AL Holder

Finish  
R/L

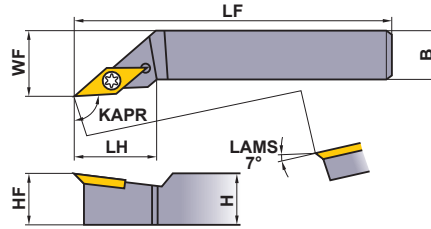

Right hand tool holder shown.

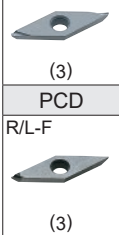

Order Number	ANSI Number	Stock		Insert Number	Dimensions (inch)						Clamp Screw*	Wrench
		R	L		H	B	LF	LH	HF	WF		
SVJDR/L-103	SVJDR/L103A	●	●	VDGX 32 $\circ$ R/L	.625	.625	4.000	1.100	.625	.750	FC400890T	TKY10F
SVJDR/L-123	SVJDR/L123B	●	●		.750	.750	4.500	1.100	.750	.875		
SVJDR/L-163	SVJDR/L163D	●	●		1.000	1.000	6.000	1.200	1.000	1.250		

Note 1) Right hand tool holder uses right hand insert. Left hand tool holder uses left hand insert.

\* Clamp Torque (lbf-in) : FC400890T=22

## RECOMMENDED CUTTING CONDITIONS

Work Material	Grade	Cutting Speed (SFM)	Feed (IPR)	Depth of Cut (inch)
N Aluminum Alloy	HTi10	1310	.002-.012	.008-.118
	MD220	2620	.002-.012	.008-.020

SVPD type inserts > A193  
SVJD type inserts > A193  
PCD inserts > B061

SPARE PARTS > M001  
TECHNICAL DATA > N001

EXTERNAL TURNING TOOLS