

PN19.01

PRODUCT NEWS

SPRING 2019

DIA  EDGE

AHB

TOOLING & MACHINERY, INC.

COMPLETE METALWORKING SOLUTIONS

(800) 991-4225

www.ahbinc.com

ISO Certified

customerservice@ahbinc.com

CRAFTED BY  MITSUBISHI MATERIALS

DIA EDGE

The

PRECISION

of our products
ensures the

PERFECTION

◆ ◆ ◆ ◆ ◆ of yours

CRAFTED BY  MITSUBISHI MATERIALS

For the skilled engineers manufacturing quality parts with tight tolerances, DIAEDGE Cutting Tools, crafted by Mitsubishi Materials, offers unparalleled performance in the service of creating a precisely perfect product, every time.



TURNING INSERTS

MP9000 Series **NEW** 6 - 27

Tools for small part machining 28 - 47

FP Breakers 48 - 49

6000 Series 50 - 56

CBN/PCD TURNING

MB4120 **NEW** 57 - 67

BC8100 Series 68 - 71

GROOVING

GW Series **NEW** 72 - 87

SOLID END MILLS

VQT6UR **NEW** 88 - 96

Smart Miracle 97 - 99

DF2XLBF 100 - 101

Impact Miracle 102 - 103

iMX 104 - 105

MILLING TOOL INSERTS

VPX **NEW** 106 - 151

WJX **NEW** 152 - 167

WSX445 168 - 169

Side Cutter Series 170 - 171

APX3000/4000 172 - 174

DRILLING

DLE Series **NEW** 175 - 183

MFE Series 184 - 185

MVX 186 - 189

New Product

INDEX

4.2019

Table Icon Reference

- USA Stock
- ★ Stocked in Japan
- Made to Order

For more information please contact your District Manager or contact our Customer Service or Technical Service Department.

Customer Service:
800.523.0800

Technical Service:
800.486.2341

TURNING

Inserts



NEW PRODUCT

9000 SERIES



**Difficult-to-cut
MATERIALS**

B214A

DIA  EDGE

The high Al-rich (Al,Ti)N single layer coating significantly reduces edge fracturing.

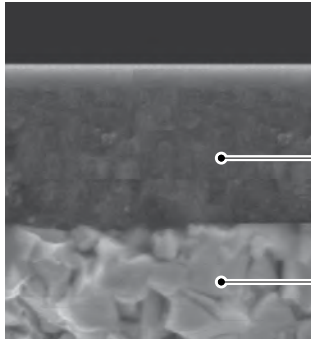

PVD Coated Grade

MP9005/MP9015/MP9025

High Al-rich (Al,Ti)N Single Layer Coating Technology

Special Cemented Carbide Substrate

MP9005/MP9015/MP9025

High Al and Conventional Coating Comparison

The high Al-rich (Al,Ti)N single layer coating provides stabilization of the high hardness phase and succeeds in dramatically improving wear, crater and welding resistance.

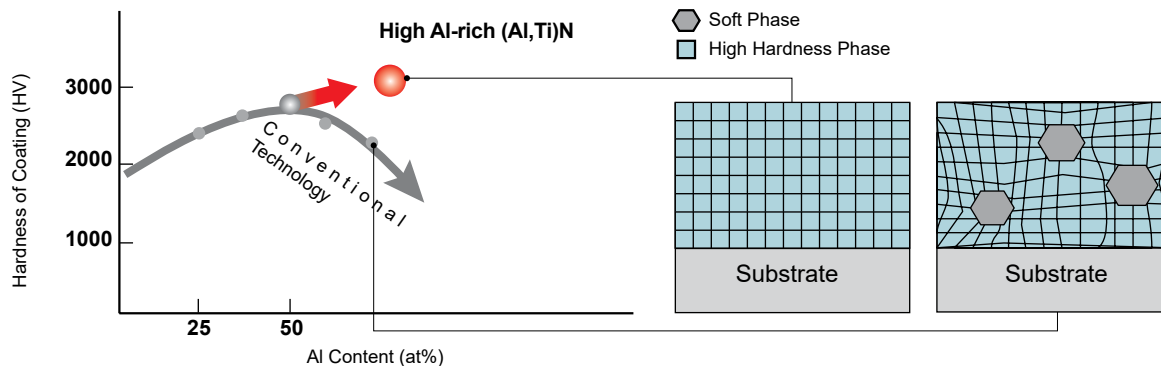

ISO Grade	Grade	Concept	Application
S01	MP9005	Top-quality grade focusing on wear resistance.	Heat Resistant Alloys / Finish Medium Cutting
S10	MP9015	First recommendation for general applications.	Heat Resistant Alloys / Medium Rough Cutting
S30	MP9025	Prevents severe damage for Increased stability.	Heat Resistant Alloys Interrupted • Light-Rough Cutting

MT9005/MT9015

Carbide Grade (Non Coated)

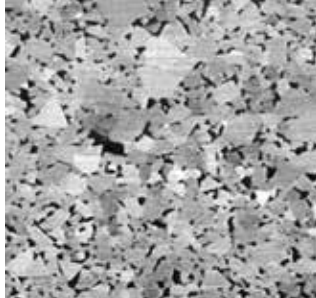

MT9005



MT9015

Application Range

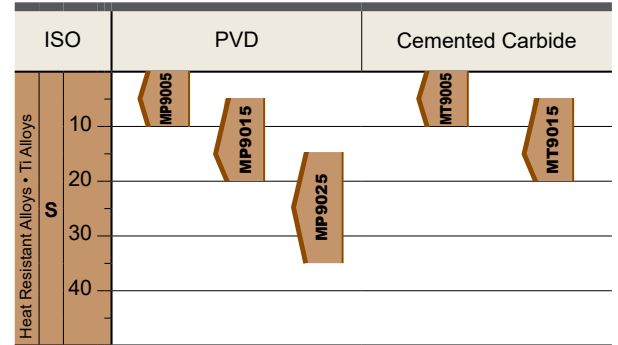

ISO Grade	Grade	Concept	Application
S01	MT9005	Cemented carbide with unmatched resistance to heat and plastic deformation.	Titanium Alloys /High Speed Cutting
S10	MT9015	Cemented carbide with sharp cutting edge, excellent wear and fracture resistance.	Titanium Alloys/General Cutting

Chip Breaker System

Negative Inserts

LS Breaker for Light Cutting

Enhanced chip disposal for depths of cut smaller than the corner R.

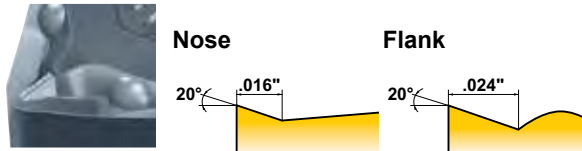
**MS Breaker** Newly Designed for Medium Cutting

The large 2-step rake angle generates chips smoothly and without tangling during low feed cutting.

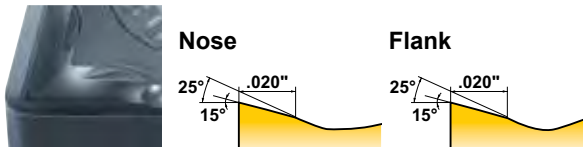
**MA Breaker** for Medium Cutting

Suitable for medium cutting range.

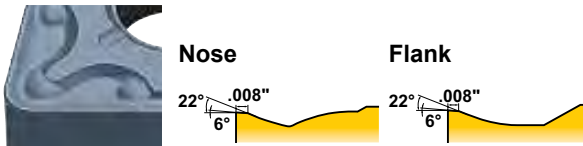
**NEW MJ Breaker** Sub Breaker

Alternative chip breaker of main chip breaker LS and MS. Excellent notch wear resistance for light to medium cutting.

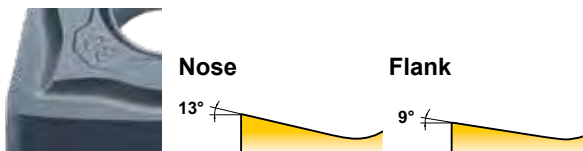
**RS Breaker** for Rough Cutting

During low speed cutting the positive land controls chip welding and abrasion at the depth of cut line.

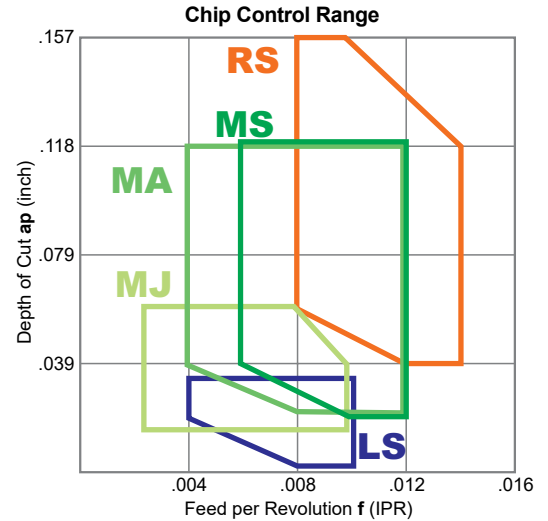
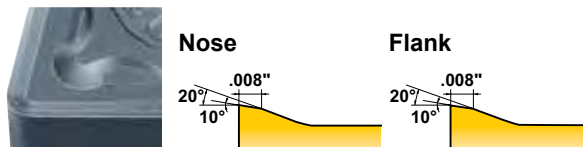

The chip breaker control range was tested for optimum chip evacuation when cutting Inconel718 with a CNMG432 \odot insert.

Chip Breaker System

Positive Inserts

LS Breaker for Light Cutting

Prevents welding of the insert and controls white turbidity of the surface finish.

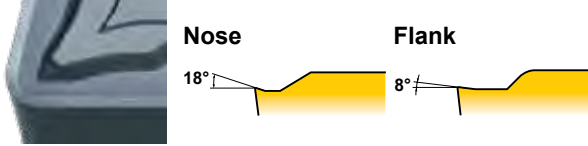

MS Breaker for Medium Cutting

The wide chip pocket reduces cutting resistance, vibration and chip jamming at large depths of cut.

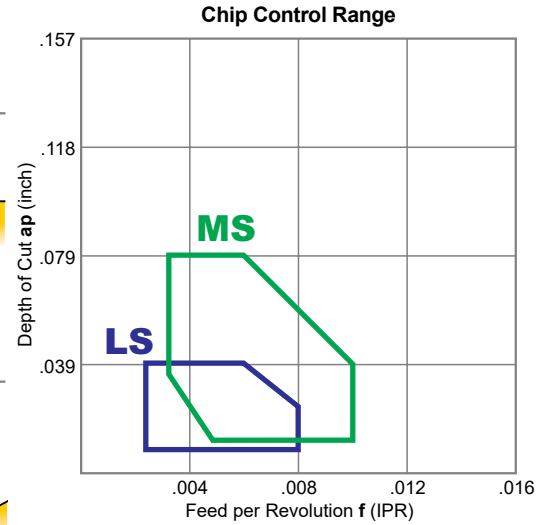
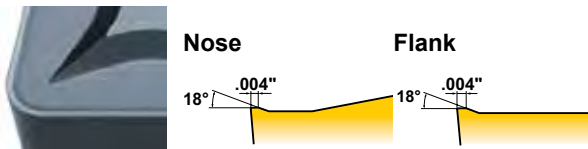

The chip breaker control range was tested for optimum chip evacuation when cutting Inconel718 with a DCMT32.51 \odot insert.

Precision Chip Breaker System

Set the corner radius to a minus tolerance

CCGT21.51MLS \rightarrow 1M RE .015 inch (RE .014-.016 inch)

FS/FS-P Breaker for Finish Cutting

FS

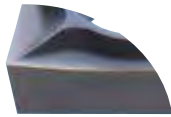

First Recommendation for Finish Cutting of Difficult-to-cut Materials

Ideal for heat resistant alloys, titanium alloys, and cobalt chromium alloys. Sharp cutting edges provide excellent surface precision and finish. Highly efficient chip discharge is possible due to curved cutting edges.

FS-P



First Recommendation for Finish Cutting of Titanium Alloys

Ideal for titanium alloys and copper alloys. Sharp cutting edges provide excellent surface precision and finish. Highly efficient chip discharge is possible due to curved cutting edges. Polished (mirror-surface) finish of insert surfaces drastically improves welding resistance extending tool life.

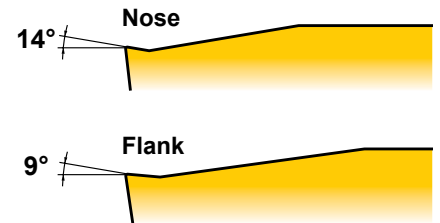

LS/LS-P Breaker for Light Cutting

LS



First Recommendation for Light Cutting of Difficult-to-cut Materials

Ideal for heat resistant alloys, titanium alloys, and cobalt chromium alloys. Designed with straight parallel cutting edges with high depth of cut capabilities. Achieves stable chip control over a wide depth of cut range.

LS-P



First Recommendation for Light Cutting of Titanium Alloys

Ideal for titanium alloys and copper alloys. Designed with straight parallel cutting edges with high depth of cut capabilities. Achieves stable chip control over a wide depth of cut range. Polished (mirror-surface) finish of insert surfaces drastically improves welding resistance.

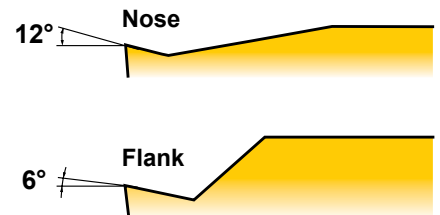
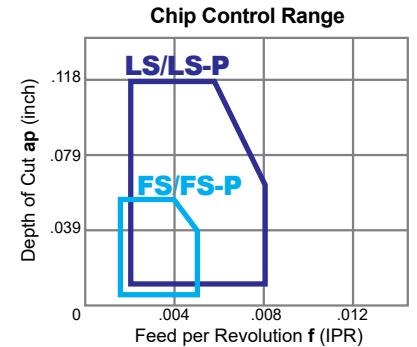

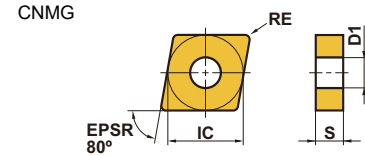
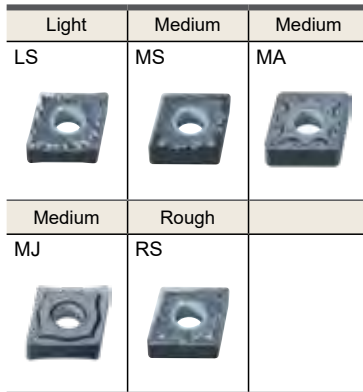
Negative Inserts (With Hole)
M Class

		(inch)							
Order Number	Cutting Area	MP9005	MP9015	NEW MP9025	MT9015	IC	S	RE	D1
NEW CNMG321LS	L	●	●			.375	.125	.016	.150
NEW CNMG322LS	L	●	●			.375	.125	.031	.150
NEW CNMG430.5LS	L	●	●		●	.500	.187	.008	.203
CNMG431LS	L	●	●	●	●	.500	.187	.016	.203
CNMG432LS	L	●	●	●	●	.500	.187	.031	.203
NEW CNMG321MS	M	●	●			.375	.125	.016	.150
NEW CNMG322MS	M	●	●			.375	.125	.031	.150
CNMG431MS	M	●	●	●	●	.500	.187	.016	.203
CNMG432MS	M	●	●	●	●	.500	.187	.031	.203
CNMG433MS	M	●	●	●	●	.500	.187	.047	.203
CNMG543MS	M	●	●		●	.625	.250	.047	.250
CNMG544MS	M	●	●		●	.625	.250	.063	.250
CNMG431MA	M		●	●		.500	.187	.016	.203
CNMG432MA	M		●	●		.500	.187	.031	.203
CNMG433MA	M		●	●		.500	.187	.047	.203
CNMG434MA	M		●			.500	.187	.063	.203
NEW CNMG431MJ	M	●	●			.500	.187	.016	.203
NEW CNMG432MJ	M	●	●			.500	.187	.031	.203
NEW CNMG433MJ	M	●	●			.500	.187	.047	.203
NEW CNMG434MJ	M	●	●			.500	.187	.063	.203
CNMG432RS	R		●	●	●	.500	.187	.031	.203
CNMG433RS	R		●	●	●	.500	.187	.047	.203
CNMG434RS	R		●	●	●	.500	.187	.063	.203
CNMG543RS	R		●		●	.625	.250	.047	.250
CNMG544RS	R		●		●	.625	.250	.063	.250
CNMG643RS	R		●		●	.750	.250	.047	.312
CNMG644RS	R		●		●	.750	.250	.063	.312

Negative Inserts (With Hole) M Class

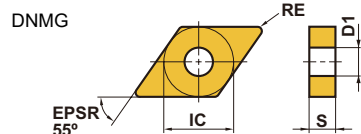

Light	Medium	Medium
LS	MS	MA
Medium	Rough	
MJ	RS	

(inch)

Order Number	Cutting Area	MP9005	MP9015	MP9025 ^{NEW}	MT9015	IC	S	RE	D1
NEW DNMG430.5LS	L	●	●	●	●	.500	.187	.008	.203
DNMG431LS	L	●	●	●	●	.500	.187	.016	.203
DNMG432LS	L	●	●	●	●	.500	.187	.031	.203
DNMG441LS	L	●	●	●	●	.500	.250	.016	.203
DNMG442LS	L	●	●	●	●	.500	.250	.031	.203
DNMG431MS	M	●	●	●	●	.500	.187	.016	.203
DNMG432MS	M	●	●	●	●	.500	.187	.031	.203
DNMG433MS	M	●	●	●	●	.500	.187	.047	.203
DNMG441MS	M	●	●	●	●	.500	.250	.016	.203
DNMG442MS	M	●	●	●	●	.500	.250	.031	.203
DNMG443MS	M	●	●	●	●	.500	.250	.047	.203
DNMG431MA	M		●			.500	.187	.016	.203
DNMG432MA	M		●	●		.500	.187	.031	.203
DNMG433MA	M		●	●		.500	.187	.047	.203
DNMG441MA	M		●			.500	.250	.016	.203
DNMG442MA	M		●	●		.500	.250	.031	.203
DNMG443MA	M		●	●		.500	.250	.047	.203
NEW DNMG431MJ	M	●	●			.500	.187	.016	.203
NEW DNMG432MJ	M	●	●			.500	.187	.031	.203
NEW DNMG433MJ	M	●	●			.500	.187	.047	.203
NEW DNMG434MJ	M	●	●			.500	.187	.063	.203
NEW DNMG441MJ	M	●	●			.500	.250	.016	.203
NEW DNMG442MJ	M	●	●			.500	.250	.031	.203
NEW DNMG443MJ	M	●	●			.500	.250	.047	.203
NEW DNMG444MJ	M	●	●			.500	.250	.063	.203
DNMG432RS	R		●	●	●	.500	.187	.031	.203
DNMG433RS	R		●	●	●	.500	.187	.047	.203
DNMG434RS	R		●		●	.500	.187	.063	.203
DNMG442RS	R		●	●	●	.500	.250	.031	.203
DNMG443RS	R		●	●	●	.500	.250	.047	.203
DNMG444RS	R		●		●	.500	.250	.063	.203

Negative Inserts (With Hole)
M Class

Medium	Medium
MS	MA
	
Rough	
RS	
	

SNMG

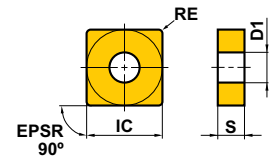

(inch)

Order Number	Cutting Area	MP9005	MP9015	NEW MP9025	MT9015	IC	S	RE	D1
SNMG431MS	M	●	●		●	.500	.187	.016	.203
SNMG432MS	M	●	●	●	●	.500	.187	.031	.203
SNMG433MS	M	●	●	●	●	.500	.187	.047	.203
SNMG543MS	M	●	●		●	.625	.250	.047	.250
SNMG544MS	M	●	●		●	.625	.250	.063	.250
NEW SNMG643MS	M	●	●			.750	.250	.047	.312
SNMG431MA	M		●			.500	.187	.016	.203
SNMG432MA	M		●			.500	.187	.031	.203
SNMG433MA	M		●			.500	.187	.047	.203
SNMG434MA	M		●			.500	.187	.063	.203
SNMG432RS	R		●	●	●	.500	.187	.031	.203
SNMG433RS	R		●	●	●	.500	.187	.047	.203
SNMG434RS	R		●		●	.500	.187	.063	.203
SNMG544RS	R		●		●	.625	.250	.063	.250
NEW SNMG643RS	R		●			.750	.250	.047	.312
SNMG644RS	R		●		●	.750	.250	.063	.312

Negative Inserts (With Hole) M Class

TNMG

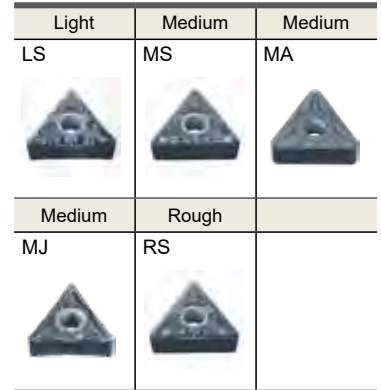
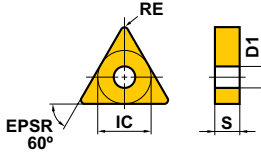

(inch)

Order Number	Cutting Area	MP9005	MP9015	MP9025 ^{NEW}	MT9015	IC	S	RE	D1
^{NEW} TNMG330.5LS	L	●	●	●	●	.375	.187	.008	.150
TNMG331LS	L	●	●	●	●	.375	.187	.016	.150
TNMG332LS	L	●	●	●	●	.375	.187	.031	.150
TNMG331MS	M	●	●		●	.375	.187	.016	.150
TNMG332MS	M	●	●	●	●	.375	.187	.031	.150
TNMG333MS	M	●	●	●	●	.375	.187	.047	.150
TNMG432MS	M	●	●		●	.500	.187	.031	.203
TNMG433MS	M	●	●		●	.500	.187	.047	.203
TNMG331MA	M		●	●		.375	.187	.016	.150
TNMG332MA	M		●	●		.375	.187	.031	.150
TNMG333MA	M		●			.375	.187	.047	.150
TNMG432MA	M		●			.500	.187	.031	.203
TNMG433MA	M		●			.500	.187	.047	.203
TNMG434MA	M		●			.500	.187	.063	.203
TNMG544MA	M		●			.625	.250	.063	.250
TNMG666MA	M		●			.750	.375	.094	.312
^{NEW} TNMG331MJ	M	●	●			.375	.187	.016	.150
^{NEW} TNMG332MJ	M	●	●			.375	.187	.031	.150
^{NEW} TNMG333MJ	M	●	●			.375	.187	.047	.150
TNMG332RS	R		●	●	●	.375	.187	.031	.150
TNMG333RS	R		●	●	●	.375	.187	.047	.150
TNMG432RS	R		●		●	.500	.187	.031	.203
TNMG433RS	R		●		●	.500	.187	.047	.203

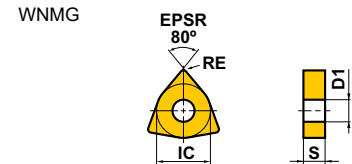
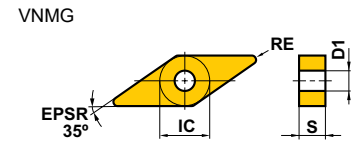
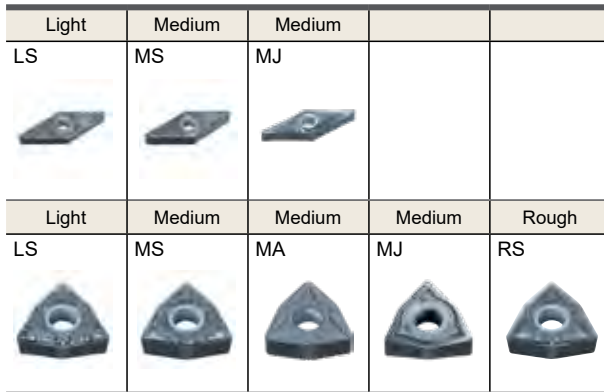
Negative Inserts (With Hole)
M Class

(inch)

Order Number	Cutting Area	MP9005	MP9015	MP9025	MT9015	IC	S	RE	D1
NEW VNMG330.5LS	L	●	●	●	●	.375	.187	.008	.150
VNMG331LS	L	●	●	●	●	.375	.187	.016	.150
VNMG332LS	L	●	●	●	●	.375	.187	.031	.150
VNMG331MS	M	●	●	●	●	.375	.187	.016	.150
VNMG332MS	M	●	●	●	●	.375	.187	.031	.150
NEW VNMG331MJ	M	●	●			.375	.187	.016	.150
NEW VNMG332MJ	M	●	●			.375	.187	.031	.150
NEW VNMG333MJ	M	●	●			.375	.187	.047	.150
NEW WNMG430.5LS	L	●	●		●	.500	.187	.008	.203
WNMG431LS	L	●	●	●	●	.500	.187	.016	.203
WNMG432LS	L	●	●	●	●	.500	.187	.031	.203
WNMG431MS	M	●	●	●	●	.500	.187	.016	.203
WNMG432MS	M	●	●	●	●	.500	.187	.031	.203
WNMG433MS	M	●	●	●	●	.500	.187	.047	.203
WNMG431MA	M		●			.500	.187	.016	.203
WNMG432MA	M		●			.500	.187	.031	.203
WNMG433MA	M		●			.500	.187	.047	.203
WNMG434MA	M		●			.500	.187	.063	.203
NEW WNMG432MJ	M	●	●			.500	.187	.031	.203
NEW WNMG433MJ	M	●	●			.500	.187	.047	.203
NEW WNMG434MJ	M	●	●			.500	.187	.063	.203
WNMG432RS	R		●	●	●	.500	.187	.031	.203
WNMG433RS	R		●	●	●	.500	.187	.047	.203
WNMG434RS	R		●		●	.500	.187	.063	.203
WNMG543RS	R		●		●	.625	.250	.047	.250

* See Index on page 4 for table icon reference. (●, ★, □)

7° Positive Inserts (With Hole) M Class

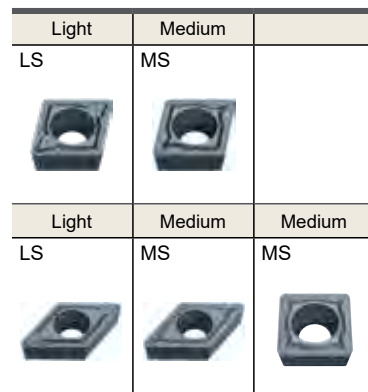
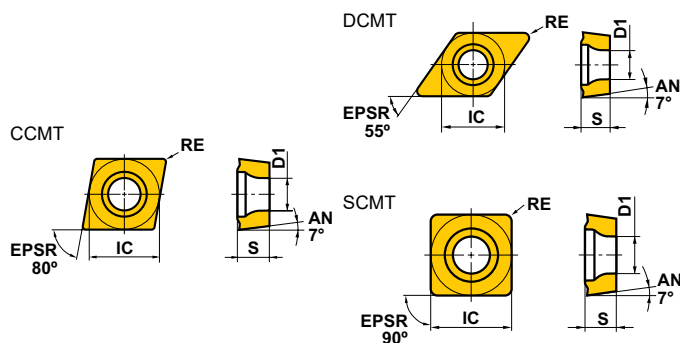

(inch)								
Order Number	Cutting Area	MP9005	MP9015	MT9005	IC	S	RE	D1
CCMT21.50.5LS	L	●	●	●	.250	.094	.008	.110
CCMT21.51LS	L	●	●	●	.250	.094	.016	.110
CCMT32.50.5LS	L	●	●	●	.375	.156	.008	.173
CCMT32.51LS	L	●	●	●	.375	.156	.016	.173
CCMT32.52LS	L	●	●	●	.375	.156	.031	.173
NEW CCMT21.50.5MS	M	●	●	●	.250	.094	.008	.110
NEW CCMT21.51MS	M	●	●	●	.250	.094	.016	.110
NEW CCMT21.52MS	M	●	●	●	.250	.094	.031	.110
NEW CCMT32.50.5MS	M	●	●	●	.375	.156	.008	.173
CCMT32.51MS	M	●	●	●	.375	.156	.016	.173
CCMT32.52MS	M	●	●	●	.375	.156	.031	.173
NEW CCMT431MS	M	●	●	●	.500	.187	.016	.217
NEW CCMT432MS	M	●	●	●	.500	.187	.031	.217
NEW CCMT433MS	M	●	●	●	.500	.187	.047	.217
DCMT21.50.5LS	L	●	●	●	.250	.094	.008	.110
DCMT21.51LS	L	●	●	●	.250	.094	.016	.110
DCMT32.50.5LS	L	●	●	●	.375	.156	.008	.173
DCMT32.51LS	L	●	●	●	.375	.156	.016	.173
DCMT32.52LS	L	●	●	●	.375	.156	.031	.173
DCMT21.51MS	M	●	●	●	.250	.094	.016	.110
DCMT21.52MS	M	●	●	●	.250	.094	.031	.110
DCMT32.51MS	M	●	●	●	.375	.156	.016	.173
DCMT32.52MS	M	●	●	●	.375	.156	.031	.173
NEW DCMT32.53MS	M	●	●	●	.375	.156	.047	.173
NEW SCMT32.51MS	M	●	●	●	.375	.156	.016	.173
NEW SCMT32.52MS	M	●	●	●	.375	.156	.031	.173
NEW SCMT431MS	M	●	●	●	.500	.187	.016	.217
NEW SCMT432MS	M	●	●	●	.500	.187	.031	.217
NEW SCMT433MS	M	●	●	●	.500	.187	.047	.217

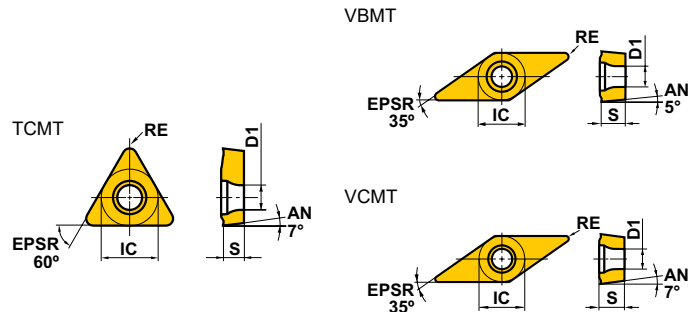
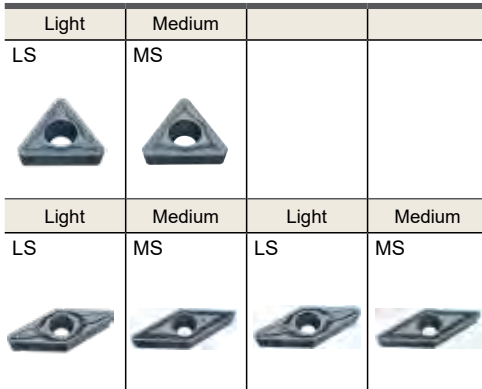
5° and 7° Positive Inserts (With Hole)
M Class

(inch)

	Order Number	Cutting Area	MP9005	MP9015	MT9005	IC	S	RE	D1
NEW	TCMT1.81.50.5LS	L	●	●	●	.219	.094	.008	.098
NEW	TCMT21.50.5LS	L	●	●	●	.250	.094	.008	.110
NEW	TCMT1.81.51MS	M	●	●	●	.219	.094	.016	.098
NEW	TCMT1.81.52MS	M	●	●	●	.219	.094	.031	.098
NEW	TCMT21.51MS	M	●	●		.250	.094	.016	.110
NEW	TCMT21.52MS	M	●	●		.250	.094	.031	.110
NEW	TCMT32.51MS	M	●	●	●	.375	.156	.016	.173
NEW	TCMT32.52MS	M	●	●	●	.375	.156	.031	.173
NEW	TCMT32.53MS	M	●	●	●	.375	.156	.047	.173
NEW	VBMT220.5LS	L	●	●	●	.250	.125	.008	.115
NEW	VBMT221LS	L	●	●	●	.250	.125	.016	.115
NEW	VBMT222LS	L	●	●	●	.250	.125	.031	.115
	VBMT331LS	L	●	●	●	.375	.187	.016	.173
	VBMT332LS	L	●	●	●	.375	.187	.031	.173
NEW	VBMT330.5MS	M	●	●	●	.375	.187	.008	.173
	VBMT331MS	M	●	●	●	.375	.187	.016	.173
	VBMT332MS	M	●	●	●	.375	.187	.031	.173
NEW	VBMT333MS	M	●	●	●	.375	.187	.047	.173
	VCMT220.5LS	L	●	●	●	.250	.125	.008	.110
	VCMT221LS	L	●	●	●	.250	.125	.016	.110
	VCMT331LS	L	●	●	●	.375	.187	.016	.173
	VCMT332LS	L	●	●	●	.375	.187	.031	.173
NEW	VCMT220.5MS	M	●	●		.250	.125	.008	.110
NEW	VCMT221MS	M	●	●	●	.250	.125	.016	.110
NEW	VCMT222MS	M	●	●	●	.250	.125	.031	.110
	VCMT331MS	M	●	●	●	.375	.187	.016	.173
	VCMT332MS	M	●	●	●	.375	.187	.031	.173

7° Positive Inserts (With Hole) G Class

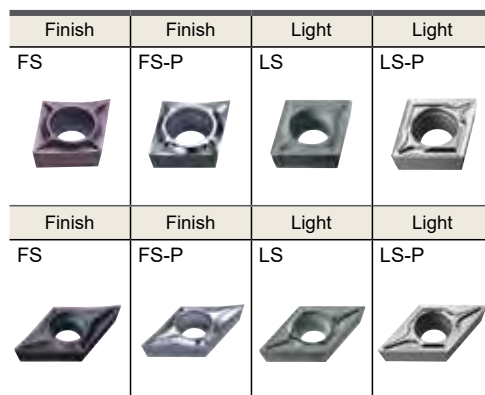
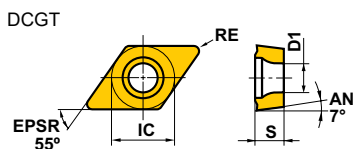
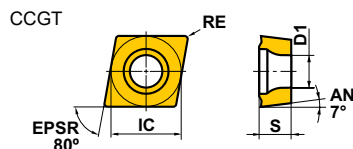

Order Number	Cutting Area	MP9005	MP9015	MT9005	IC	S	RE	D1
CCGT21.50.2MFS	F	●	●		.250	.094	.003	.110
CCGT21.50.5MFS	F	●	●		.250	.094	.007	.110
CCGT32.50.2MFS	F	●	●		.375	.156	.003	.173
CCGT32.50.5MFS	F	●	●		.375	.156	.007	.173
CCGT32.51MFS	F	●	●		.375	.156	.015	.173
CCGT21.50.2MFS-P	F			●	.250	.094	.003	.110
CCGT21.50.5MFS-P	F			●	.250	.094	.007	.110
CCGT32.50.2MFS-P	F			●	.375	.156	.003	.173
CCGT32.50.5MFS-P	F			●	.375	.156	.007	.173
CCGT32.51MFS-P	F			●	.375	.156	.015	.173
CCGT21.50.2MLS	L	●	●		.250	.094	.003	.110
CCGT21.50.5MLS	L	●	●		.250	.094	.007	.110
CCGT32.50.2MLS	L	●	●		.375	.156	.003	.173
CCGT32.50.5MLS	L	●	●		.375	.156	.007	.173
CCGT32.51MLS	L	●	●		.375	.156	.015	.173
CCGT21.50.2MLS-P	L			●	.250	.094	.003	.110
CCGT21.50.5MLS-P	L			●	.250	.094	.007	.110
CCGT32.50.2MLS-P	L			●	.375	.156	.003	.173
CCGT32.50.5MLS-P	L			●	.375	.156	.007	.173
CCGT32.51MLS-P	L			●	.375	.156	.015	.173
DCGT21.50.2MFS	F	●	●		.250	.094	.003	.110
DCGT21.50.5MFS	F	●	●		.250	.094	.007	.110
DCGT32.50.2MFS	F	●	●		.375	.156	.003	.173
DCGT32.50.5MFS	F	●	●		.375	.156	.007	.173
DCGT21.50.2MFS-P	F			●	.250	.094	.003	.110
DCGT21.50.5MFS-P	F			●	.250	.094	.007	.110
DCGT32.50.2MFS-P	F			●	.375	.156	.003	.173
DCGT32.50.5MFS-P	F			●	.375	.156	.007	.173
DCGT21.50.2MLS	L	●	●		.250	.094	.003	.110
DCGT21.50.5MLS	L	●	●		.250	.094	.007	.110
DCGT21.51MLS	L	●	●		.250	.094	.015	.110
DCGT32.50.2MLS	L	●	●		.375	.156	.003	.173
DCGT32.50.5MLS	L	●	●		.375	.156	.007	.173
DCGT32.51MLS	L	●	●		.375	.156	.015	.173
DCGT21.50.2MLS-P	L			●	.250	.094	.003	.110
DCGT21.50.5MLS-P	L			●	.250	.094	.007	.110
DCGT21.51MLS-P	L			●	.250	.094	.015	.110
DCGT32.50.2MLS-P	L			●	.375	.156	.003	.173
DCGT32.50.5MLS-P	L			●	.375	.156	.007	.173
DCGT32.51MLS-P	L			●	.375	.156	.015	.173

7° Positive Inserts (With Hole)
G Class

Light

LS



Light

LS-P



VCGT

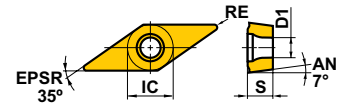

(inch)

Order Number	Cutting Area	MP9005	MP9015	MT9005	IC	S	RE	D1
VCGT220.2MLS	L	●	●		.250	.125	.003	.110
VCGT220.5MLS	L	●	●		.250	.125	.007	.110
VCGT221MLS	L	●	●		.250	.125	.015	.110
VCGT2.520.2MLS	L	●	●		.313	.125	.003	.134
VCGT2.520.5MLS	L	●	●		.313	.125	.007	.134
VCGT2.521MLS	L	●	●		.313	.125	.015	.134
VCGT220.2MLS-P	L			●	.250	.125	.003	.110
VCGT220.5MLS-P	L			●	.250	.125	.007	.110
VCGT221MLS-P	L			●	.250	.125	.015	.110
VCGT2.520.2MLS-P	L			●	.313	.125	.003	.134
VCGT2.520.5MLS-P	L			●	.313	.125	.007	.134
VCGT2.521MLS-P	L			●	.313	.125	.015	.134

Recommended Cutting Conditions

Negative Inserts

(inch)

Workpiece Material	Cutting Conditions	Cutting Area	Chip Breaker	Grade	Cutting Speed vc (SFM)	Feed f (IPR)	Depth of Cut ap	
M Precipitation Hardening Stainless Steels (AISI 630)	Stable Cutting	Light Cutting	LS	MP9005	410 – 575	.004 – .010	.008 – .031	
		Medium Cutting	MS	MP9005	375 – 525	.004 – .010	.020 – .157	
		Rough Cutting	RS	MP9015	345 – 490	.008 – .014	.039 – .157	
	General Cutting	Light Cutting	LS	MP9015	395 – 540	.004 – .010	.008 – .031	
		Medium Cutting	MS	MP9015	360 – 490	.004 – .010	.020 – .157	
		Rough Cutting	RS	MP9015	330 – 460	.008 – .014	.039 – .157	
	Unstable Cutting	Light Cutting	LS	MP9025	260 – 310	.004 – .010	.008 – .031	
		Medium Cutting	MS	MP9025	245 – 295	.006 – .020	.020 – .157	
		Rough Cutting	RS	MP9025	230 – 280	.008 – .014	.039 – .157	
S Titanium Alloys (Ti-6Al-4V)	Stable Cutting	Light Cutting	LS	MT9015	130 – 280	.004 – .010	.008 – .031	
		Medium Cutting	MS	MT9015	130 – 260	.004 – .010	.020 – .157	
		Rough Cutting	RS	MT9015	115 – 245	.008 – .014	.039 – .157	
	General Cutting	Light Cutting	LS	MT9015	130 – 280	.004 – .010	.008 – .031	
		Medium Cutting	MS	MT9015	130 – 260	.004 – .010	.020 – .157	
		Rough Cutting	RS	MT9015	115 – 245	.008 – .014	.039 – .157	
	Ni Based Heat Resistant Alloys (Inconel718, Hastelloy, Waspaloy) Co Based Heat Resistant Alloys (Tribaloy, Stellite)	Stable Cutting	Light Cutting	LS	MP9005	100 – 360	.004 – .010	.008 – .031
			Medium Cutting	MS	MP9005	100 – 330	.004 – .010	.020 – .157
			Rough Cutting	RS	MP9015	65 – 245	.008 – .014	.039 – .157
General Cutting		Light Cutting	LS	MP9015	80 – 280	.004 – .010	.008 – .031	
		Medium Cutting	MS	MP9015	80 – 260	.004 – .010	.020 – .157	
		Rough Cutting	RS	MP9015	65 – 245	.008 – .014	.039 – .157	
Unstable Cutting		Light Cutting	LS	MP9025	65 – 100	.004 – .010	.008 – .031	
		Medium Cutting	MS	MP9025	65 – 100	.004 – .010	.020 – .157	
		Rough Cutting	RS	MP9025	50 – 80	.008 – .014	.039 – .157	

Note 1) When cutting conditions are unstable, please refer to pages 9-10 for recommended chip breaker and grade.

Note 2) Verify the recommended conditions for each boring bar as cutting conditions for internal machining will vary depending on the length of overhang.

Note 3) MC7015, MC7025 and MP7035 grade are also recommended for precipitation hardening stainless steels.

Recommended Cutting Conditions

Positive Inserts

(inch)

Workpiece Material	Cutting Conditions	Cutting Area	Chip Breaker	Grade	Cutting Speed vc (SFM)	Feed f (IPR)	Depth of Cut ap
M Precipitation Hardening Stainless Steels (AISI 630)	Stable Cutting	Light Cutting	LS	MP9015	345 – 460	.002 – .008	.008 – .039
		Medium Cutting	MS	MP9015	280 – 395	.003 – .010	.012 – .079
	General Cutting	Light Cutting	LS	MP9015	345 – 460	.002 – .008	.008 – .039
		Medium Cutting	MS	MP9015	280 – 395	.003 – .010	.012 – .079
S Titanium Alloys (Ti-6Al-4V)	Stable Cutting	Finish and Light	LS	MT9005	130 – 260	.002 – .008	.008 – .039
		Medium Cutting	MS	MT9005	115 – 210	.003 – .010	.012 – .079
	General Cutting	Finish and Light	LS	MT9005	130 – 260	.002 – .008	.008 – .039
		Medium Cutting	MS	MT9005	115 – 210	.003 – .010	.012 – .079
	Unstable Cutting	Finish and Light	LS	MT9005	130 – 260	.002 – .008	.008 – .039
		Medium Cutting	MS	MT9005	115 – 210	.003 – .010	.012 – .079
Ni Based Heat Resistant Alloys (Inconel718, Hastelloy, WASPALLOY)	Stable Cutting	Finish and Light	LS	MP9005	80 – 310	.002 – .008	.008 – .039
		Medium Cutting	MS	MP9005	65 – 260	.003 – .010	.012 – .079
	General Cutting	Finish and Light	LS	MP9015	65 – 245	.002 – .008	.008 – .039
		Medium Cutting	MS	MP9015	65 – 195	.003 – .010	.012 – .079
	Unstable Cutting	Finish and Light	LS	MP9015	65 – 245	.002 – .008	.008 – .039
		Medium Cutting	MS	MP9015	65 – 195	.003 – .010	.012 – .079

Recommended Cutting Conditions

Precision Positive Inserts (inch)							
Workpiece Material	Cutting Conditions	Chip Breaker	Grade	Cutting Speed vc (SFM)	Feed f (IPR)	Depth of Cut ap	
M Precipitation Hardening Stainless Steels (AISI 630)	Stable Cutting	FS	MP9005	130 – 260	.002 – .004	.008 – .055	
		LS	MP9005	130 – 260	.002 – .006	.012 – .079	
	General Cutting	FS	MP9015	130 – 260	.002 – .004	.008 – .055	
		LS	MP9015	130 – 260	.002 – .006	.012 – .079	
	Unstable Cutting	LS	MP9015	100 – 195	.002 – .004	.012 – .039	
	S	Stable Cutting	FS-P	MT9005	130 – 260	.002 – .005	.008 – .055
LS-P			MT9005	130 – 260	.002 – .008	.012 – .118	
General Cutting		FS-P	MT9005	130 – 260	.002 – .005	.008 – .055	
		LS-P	MT9005	130 – 260	.002 – .005	.012 – .079	
Unstable Cutting		FS-P	MT9005	100 – 195	.002 – .004	.008 – .055	
Cobalt Chromium Alloys (Co-Cr-Mo Alloys)		Stable Cutting	FS	MP9005	130 – 260	.002 – .004	.008 – .055
			LS	MP9005	130 – 260	.002 – .006	.012 – .079
		General Cutting	FS	MP9015	130 – 260	.002 – .004	.008 – .055
			LS	MP9015	130 – 260	.002 – .006	.012 – .079
Unstable Cutting		LS	MP9015	100 – 195	.002 – .004	.012 – .039	
Ni Based Heat Resistant Alloys (Inconel718, Hastelloy, WASTALLOY)		Stable Cutting	FS	MP9005	80 – 310	.002 – .005	.008 – .055
			LS	MP9005	80 – 310	.002 – .005	.012 – .079
	General Cutting	FS	MP9015	65 – 245	.002 – .005	.008 – .055	
		LS	MP9015	65 – 245	.002 – .005	.012 – .079	
Unstable Cutting	FS	MP9015	65 – 245	.002 – .005	.008 – .055		

For Effective Use of Large Corner Radius

By setting the depth of cut smaller than the corner radius value, notching during cutting of heat resistant alloys can be greatly reduced.

Corner Radius > 1.5 x Depth of Cut

Depth of cut: .024 inch. Corner radius over .035 inch is recommended.

Point

A smaller lead angle is the key to reduced notching.

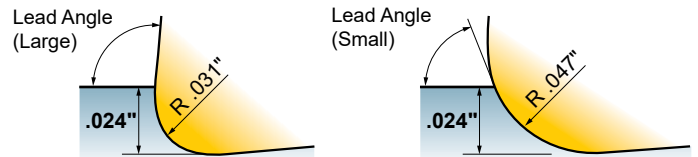

Cutting Performance

Comparison in Continuous Machining of AISI 630

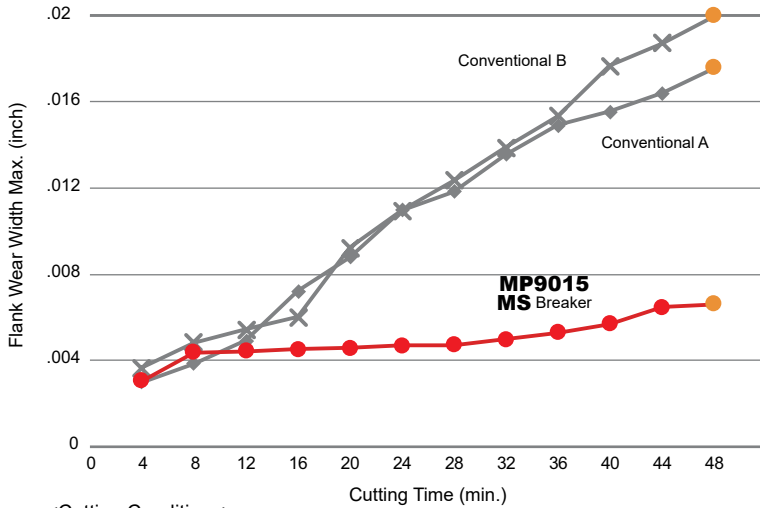

<Cutting Conditions>

Workpiece Material : AISI 630
 Inserts : CNMG432
 Machining Methods : External Continuous Cutting
 Cutting Speed : vc=395 SFM
 Feed per Rev. : f=.008 IPR
 Depth of Cut : ap=.059 inch
 Cutting Mode : Wet Cutting

Cutting Time : 48min (Wear Photo)

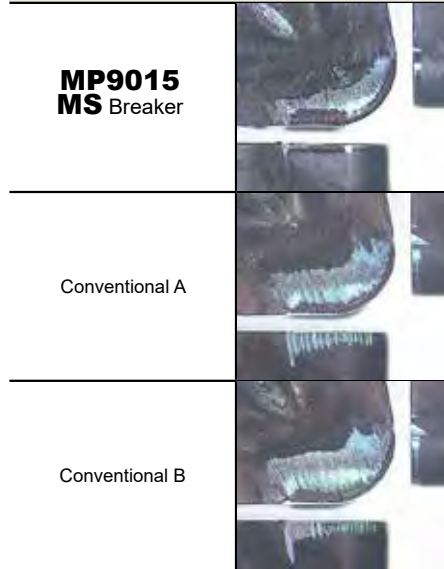

Achieved 2X tool life when machining Inconel718 during continuous machining.

MP9005+LS Conventional A (S10) Conventional B (S10) Conventional C (S10)



Wear - .0094 inch Wear - .0087 inch Wear - .0091 inch Wear - .0098 inch
 Cutting Time 66 min Cutting Time 22 min Cutting Time 36 min Cutting Time 16 min

<Cutting Conditions>

Workpiece Material : Inconel718
 Inserts : CNMG432
 Cutting Speed : vc= 165 SFM
 Feed per Rev. : f=.006 IPR
 Depth of Cut : ap=.020 inch
 Cutting Mode : Wet Cutting

Comparison of Wear Resistance by Workpiece Material

Workpiece Materials and Cutting Conditions	Chip Breaker	Conventional A	Conventional B
Workpiece Material : Co-Cr-Mo Alloy Inserts : DCGT32.51MLS Grade : MP9005 Cutting Speed : vc=130 SFM Feed per Rev. : f=.002 IPR Depth of Cut : ap=.008 inch Cutting Mode : Wet Cutting (Water-soluble) Machine : Swiss Style Lathes Cutting Time : 12 min.			
Workpiece Material : Inconel718 Inserts : DCGT32.51MLS Grade : MP9015 Cutting Speed : vc=195 SFM Feed per Rev. : f=.002 IPR Depth of Cut : ap=.020 inch Cutting Mode : Wet Cutting (Water-soluble) Machine : Swiss Style Lathes Cutting Time : 20 min.			
Workpiece Material : Ti-6Al-4V ELI Inserts : DCGT32.51MLS-P Grade : MT9005 Cutting Speed : vc=260 SFM Feed per Rev. : f=.002 IPR Depth of Cut : ap=.118 inch Cutting Mode : Wet Cutting (Water-insoluble) Machine : Automatic Lathes			
	35 Pieces (Non-coat)	35 Pieces (PVD)	15 Pieces (PVD)

* See Index on page 4 for table icon reference. (●, ★, □)

Cutting Performance

Inconel718, vc=195SFM Continuous Machining

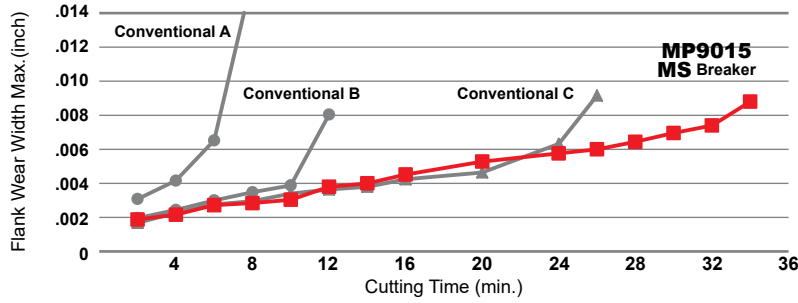

<Cutting Conditions>

Workpiece Material : Inconel718
 Inserts : CNMG432
 Cutting Speed : vc=195SFM
 Feed per Rev. : f=.006IPR
 Depth of Cut : ap=.030inch
 Cutting Mode : Wet Cutting



Conventional A
8 min



Conventional B
12 min



Conventional C
26 min



**MP9015
MS Breaker, 34 min**

**Increased
28%
Tool Life**

Inconel718, vc=330SFM Continuous Machining

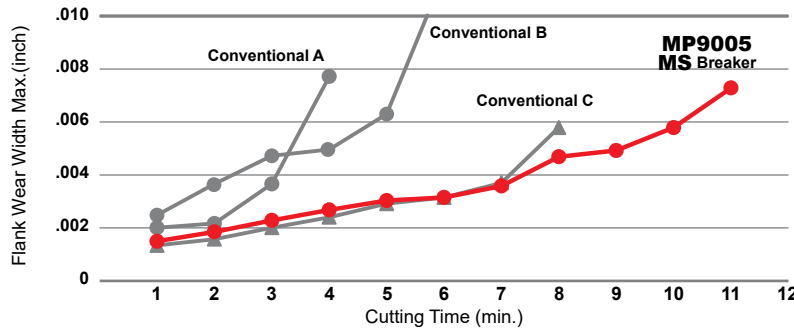

<Cutting Conditions>

Workpiece Material : Inconel718
 Inserts : CNMG432
 Cutting Speed : vc=330SFM
 Feed per Rev. : f=.006IPR
 Depth of Cut : ap=.020inch
 Cutting Mode : Wet Cutting



Conventional A
4 min



Conventional B
6 min



Conventional C
8 min



**MP9005
MS Breaker, 11 min**

**Increased
37%
Tool Life**

Inconel718, ap=.079 inch Continuous Machining

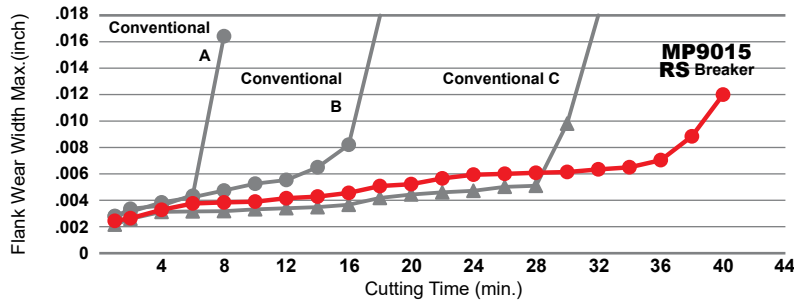

<Cutting Conditions>

Workpiece Material : Inconel718
 Inserts : CNMG432
 Cutting Speed : vc=130SFM
 Feed per Rev. : f=.008IPR
 Depth of Cut : ap=.079inch
 Cutting Mode : Wet Cutting



Conventional A
8 min



Conventional B
18 min



Conventional C
32 min



**MP9015
RS Breaker, 40 min**

**Increased
33%
Tool Life**

Cutting Performance

Titanium Alloy, Comparison of Surface Finish (Depth of Cut: .01 inch)

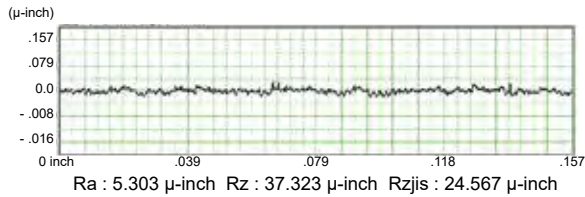

Glossy Surface

.197 inch

**MT9015
LS Breaker**

White Turbidity

.197 inch

ConventionalExcellent
Finish

<Cutting Conditions>

Workpiece Material : Ti-6Al-6V(325HB)

Inserts : CNMG432

Cutting Speed : $vc=230 \text{ SFM}$ Feed per Rev. : $f=.002 \text{ IPR}$ Depth of Cut : $ap=.01 \text{ inch}$

Cutting Mode : Wet Cutting

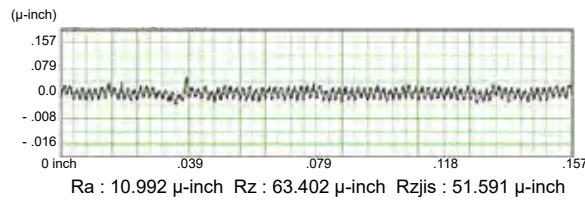

MP9015 with LS breaker was smallest damage.

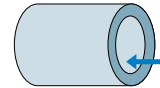

Conventional

**MP9015 LS Breaker**

<Cutting Conditions>

Workpiece Material : Heat Resistant Cast Steel

Inserts : DCMT32.51

Cutting Speed : $vc=330 \text{ SFM}$ Feed per Rev. : $f=.004 \text{ IPR}$ Depth of Cut : $ap=.010 \text{ inch}$

Cutting Mode : Wet Cutting

Chip Control when Back Turning

Non-tangling of chips when back turning Inconel718.

**MS Breaker
New Design**

Conventional

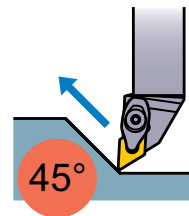

<Cutting Conditions>

Workpiece Material : Inconel718

Inserts : DNMG432

Cutting Speed : $vc=130 \text{ SFM}$ Feed per Rev. : $f=.008 \text{ IPR}$ Depth of Cut : $ap=.0039 \text{ inch}$

Cutting Mode : Wet Cutting

WASPALOY Continuous Machining

MP9015 with RS breaker was smallest damage.



Conventional A



Conventional B

**MP9015
RS Breaker**

<Cutting Conditions>

Workpiece Material : WASPALOY

Inserts : CNMG432

Cutting Speed : $vc=95 \text{ SFM}$ Feed per Rev. : $f=.009 \text{ IPR}$ Depth of Cut : $ap=.157 \text{ inch}$

Cutting Time : 7 min

Cutting Mode : Wet Cutting

Inconel718, vc=100 SFM Interrupted Machining

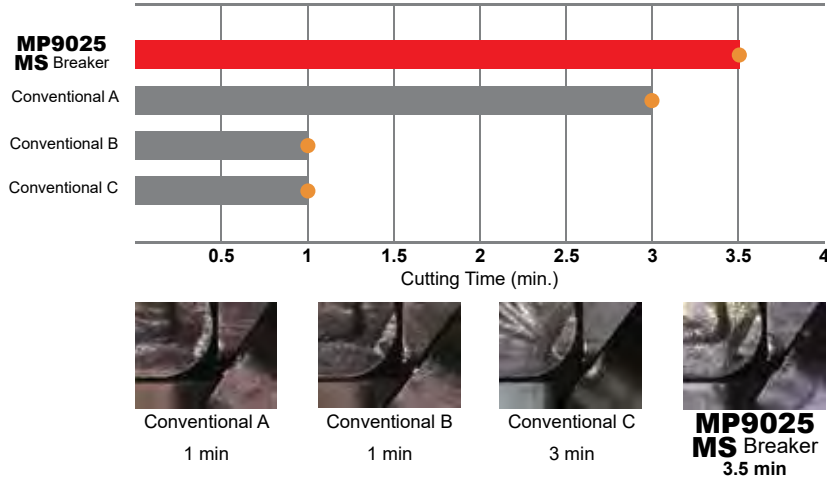

<Cutting Conditions>
 Workpiece Material : Inconel718
 Inserts : CNMG43200
 Cutting Speed : vc= 100 SFM
 Feed per Rev. : f=.004 IPR
 Depth of Cut : ap=.01 inch
 Cutting Mode : Wet Cutting

**Increased
16 %
Tool Life**





Application Examples

Inserts (Grade)		DCGT32.51MLS (MP9015)	DCGT32.50.5MLS (MP9015)
Workpiece Material		AISI 430 (Forgings)	AISI 630 (17-4PH)
Cutting Conditions	Cutting Speed vc (SFM)	260	195
	Feed per Rev. f (IPR)	.0031	.0016
	Depth of Cut ap (inch)	.012	.012
Cutting Mode		Wet Cutting (Water-insoluble Coolants)	Wet Cutting (Water-insoluble Coolants)
Machine		Swiss Style Lathes	Swiss Style Lathes
Results		Compared to conventional product with inconsistent tool life, whose unstable chip evacuation can cause entanglement of chips in workpiece materials, the LS breaker provided stable chip evacuation allowing machining to be performed up to machining constants. It also exhibited excellent wear conditions after turning.	Even when machining at 1.5X the existing conditions of conventional product, there were no variations in turning surface dimensions. The amount of wear was also extremely small, resulting in longer tool life and cost reduction.

Inserts (Grade)		DCGT32.50.5MFS-P (MT9005)	DCGT21.50.2MFS (MP9015)
Workpiece Material		Ti-6Al-4V ELI	AISI 304
Cutting Conditions	Cutting Speed vc (SFM)	210	260
	Feed per Rev. f (IPR)	.0024	.0020
	Depth of Cut ap (inch)	.030	.012
Cutting Mode		Wet Cutting (Water-insoluble Coolants)	Wet Cutting (Water-insoluble Coolants)
Machine		Swiss Style Lathes	Swiss Style Lathes
Results		Compared to conventional PVD coated product, the cemented carbide MT 9005 (uncoated) provided exceptional machined surface roughness even at 2X the number of cuts. The extremely small amount of wear and stable dimensional precision allowed further machining extension.	Compared to conventional product, the amount of wear was small and chip evacuation was excellent, making it possible to perform machining at 1.5X the existing conditions.

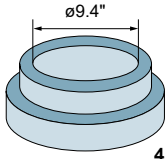
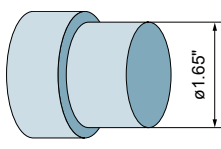
The above application examples are customer's applications, so it can be different from the recommended conditions.

Application Examples

Inserts (Grade)		DNMG432MS (MP9005)	CNMG432RS (MP9015)
Workpiece		Inconel718 (Ni Based Heat Resistant Alloy)	HAYNES Alloy 25 (Co Based Heat Resistant Alloy)
		 <p>45HRC Aging Treatment</p>	
Component		Disk - Aerospace Component	Cover Plate - Aerospace Component
Application		Internal Turning	External Turning
Cutting Conditions	Cutting Speed v_c (SFM)	195	110
	Feed per Rev. f (IPR)	.006	.008
	Depth of Cut $a_p \times a_e$.010 x .591	.059 x 1.654 (3 Pass)
Cutting Mode		Wet Cutting	Wet Cutting
Results		<div style="display: flex; justify-content: space-around;"> <div style="text-align: center;"> <p>Conventional (S10)</p>  </div> <div style="text-align: center;"> <p>MP9005+MS</p>  </div> </div> <p>MP9005 - Stable machining and less wear with long tool life without chip tangling.</p>	<div style="display: flex; justify-content: space-around;"> <div style="text-align: center;"> <p>Conventional (S10)</p>  </div> <div style="text-align: center;"> <p>MP9015+RS</p>  </div> </div> <p>Both conventional and MP9015 display notch wear but the conventional grade wear was greater and exposed the substrate.</p>

The above application examples are customer's applications, so it can be different from the recommended conditions.

DIA  **EDGE**

TOOLS for Small Part Machining

◆ ◆ ◆ ◆ ◆

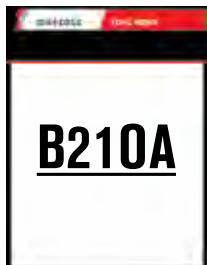

- ◆ PVD Coated Cemented Carbide Grade for Carbon Steels
- ◆ Designed for performance in irons, carbon steels, and free cutting steels.

Insert Grades

A fine grain carbide substrate and a new PVD coating that greatly improves wear resistance.

	MS6015	Conventional
Coating	TiCN Multilayer	TiAlN
Hardness (HV)	3000	2800
Wear Coefficient (Carbon Steels)	Low	High
Base Material Hardness (HRA)	92.0	92.0
T.R.S (GPa)	2.0	2.0

Ti-C-N Multilayer Coating

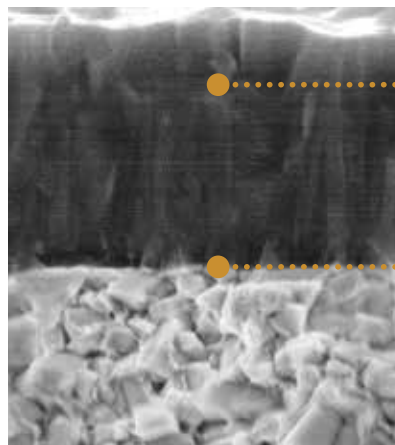

Superior wear and welding resistance and demonstrating the best possible results for carbon steels.

Minute multilayers remarkably improve welding.

Extremely smooth PVD coating means excellent chip evacuation resulting in good wall surface finish and long tool life.

Optimizing the Laminated Structure

Optimizing the laminated structure enables the thickening of coating which leads to significant wear resistance.

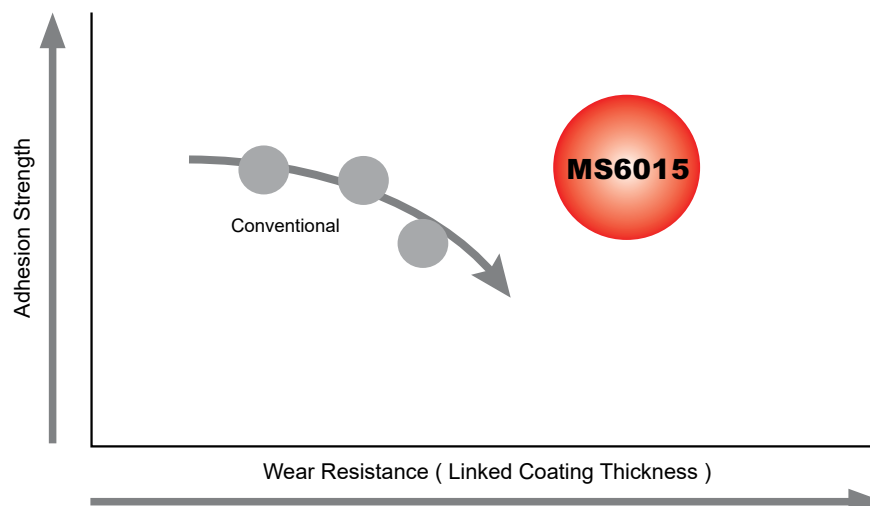

* See Index on page 4 for table icon reference. (●, ★, □)

MS6015

Chipbreakers

Set the corner radius to a minus tolerance.

Order Number **DCGT32.5 0.5 M RSN** → **0.5M R.007 inch (R.006 – R.008 inch)**
DCGT32.5 1 M SMG → **1M R.015 inch (R.014 – R.016 inch)**

Light Cutting **LS-P** Breaker

◆ **Surface treatment before coating drastically improves welding resistance extending tool life.**

◆ **By flattening the substrate surface, the coating particles crystals form straightly, leading to stable cutting and welding prevention.**

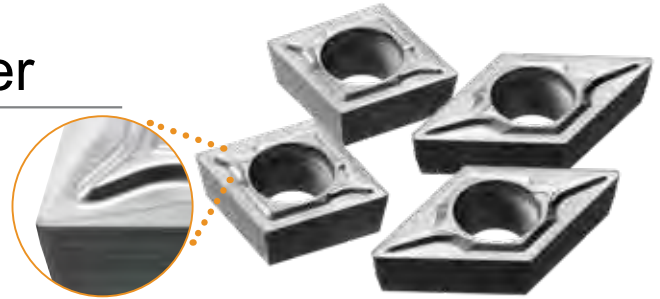

*Graphical Representation.

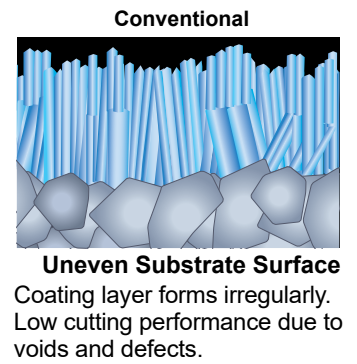
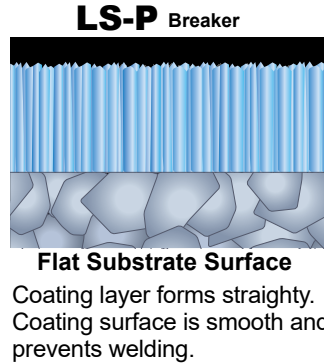

Cutting Performance

Surface Roughness in Soft Magnetic Iron Cutting

High quality worked surface preventing cloudiness.

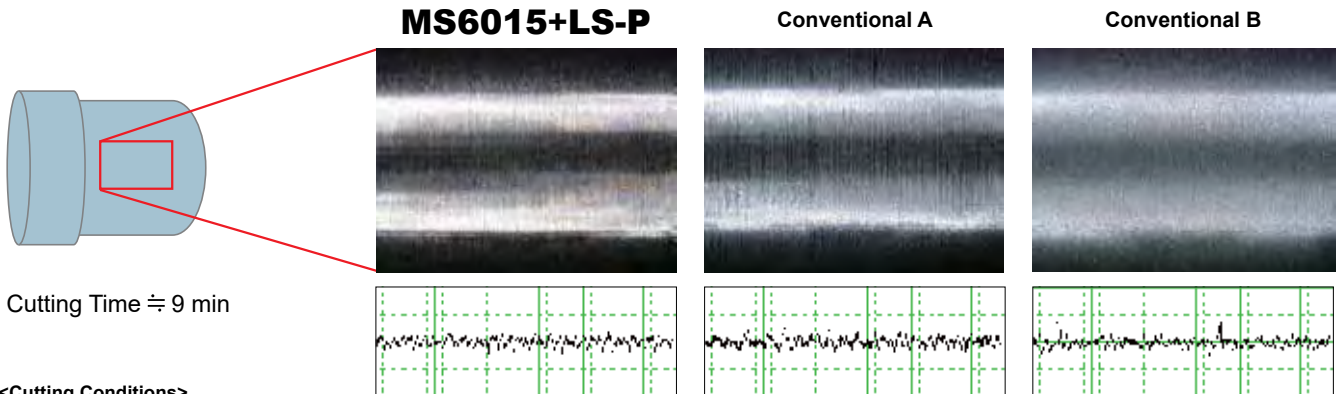

Cutting Time ≒ 9 min

<Cutting Conditions>
 Workpiece Material : ELCH2
 Insert : DCGT32.50.5MLS-P
 Grade : MS6015
 Cutting Speed : vc=330 SFM
 Feed per Rev. : f=.001 IPR
 Depth of Cut : ap=.020 inch
 Cutting Mode : Wet Cutting (Water-insoluble)
 Machine : Swiss Style Lathes

TOOLS FOR SMALL PART MACHINING

SMB Breaker

- ◆ Pressed Insert for Back Turning
- ◆ Outstanding surface finish in back turning applications from a pressed geometry.

Design

Eliminates the need for rough and finish passes.
Achieves a stable tool life by adopting VP15TF that can be used for many types of workpiece material.

Prevents the biting of the chip at end face when grooving.
Geometry stabilizes insert when plunging of grooving.

Good surface finish from wiper geometry.

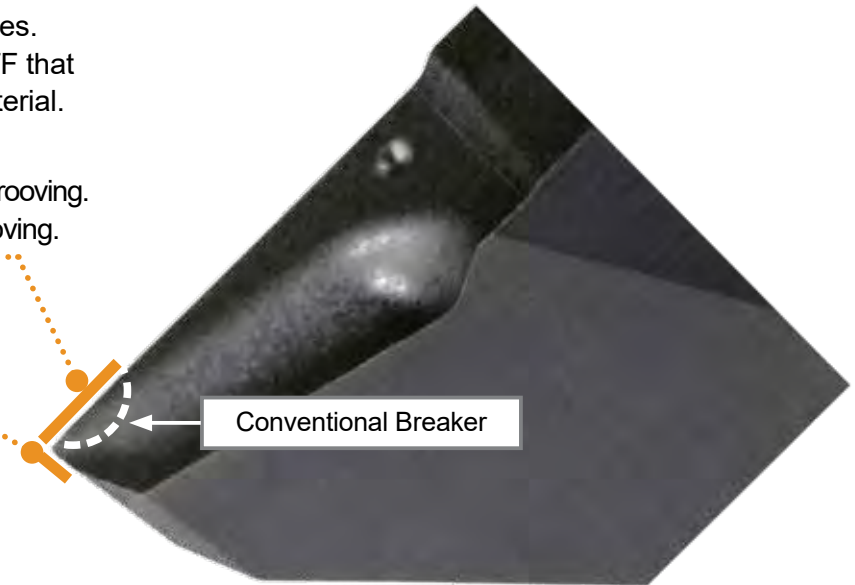
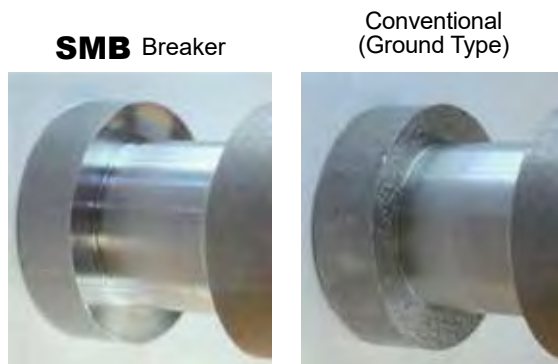

Set the Corner Radius to a Minus Tolerance
01M : R.0031" 02M : .0071"

<Cutting Conditions>

Workpiece Material : Low Carbon Steels
Inserts : BTAT723501MR-SMB
Grade : VP15TF
Cutting Speed : $vc=330$ SFM
Depth of Cut : $ap=.098$ inch
Feed (Grooving) : $f=.0012$ IPR
Feed (External) : $f=.0016$ IPR
Cutting Mode : Wet Cutting (Water-soluble)
Machine : Swiss Style Lathes

Cutting Performance

Superior wear resistance compared to ground inserts - even in difficult workpiece materials such as AISI 304SS.

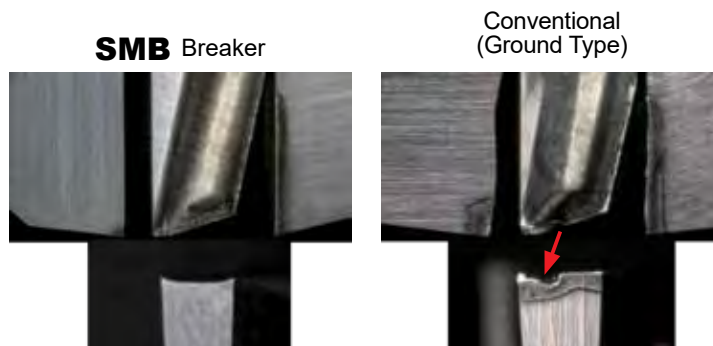

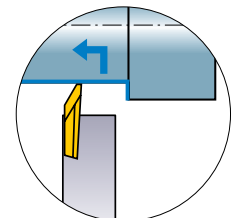

<Cutting Conditions>

Workpiece Material : AISI 304
Inserts : BTAT723501MR-SMB
Grade : VP15TF
Cutting Speed : $vc=195$ SFM
Depth of Cut : $ap=.098$ inch
Feed (Grooving) : $f=.0008$ IPR
Feed (External) : $f=.0016$ IPR
Number of Workpieces : 100 pieces
Cutting Mode : Wet Cutting (Water-insoluble)
Machine : Swiss Style Lathes





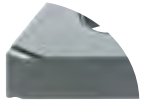
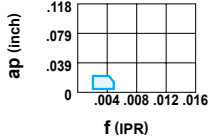



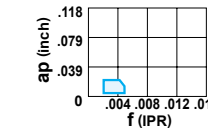

Breaker System

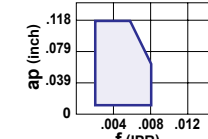
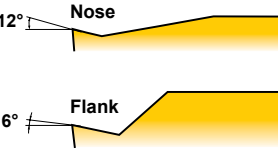
Negative Inserts

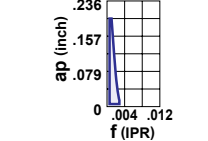
Application	Tolerance	Breaker Name and Picture	Features	Cross Section Geometry
Finish Cutting	G	R/L-FS 	Precise Finishing Double-sided chip breaker. A narrow lead chip breaker for good chip control. Sharp cutting edge gives a good surface finish.	Carbon Steel • Alloy Steel ap (inch) vs f (IPR) graph  Flank 14° 

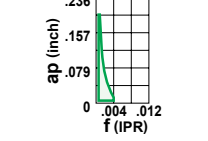
Positive Inserts

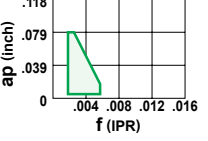
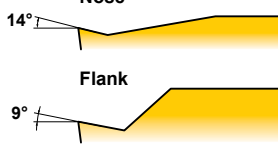
Application	Tolerance	Breaker Name and Picture	Features	Cross Section Geometry
Finish Cutting	G	R/L-F 	Finish Cutting of Swiss Style Lathes Lead chip breaker controls chip flow. Sharp cutting edge gives a good surface finish.	Carbon Steel • Alloy Steel ap (inch) vs f (IPR) graph  Flank 17° 
Light Cutting	G	LS-P 	Light Cutting of Swiss Style Lathes Designed with parallel cutting edges. Achieves stable chip control over a wide range from low to medium depths of cut. Surface treatment before coating drastically improves welding resistance extending tool life.	Carbon Steel • Alloy Steel ap (inch) vs f (IPR) graph  Nose 12° Flank 6° 
	G	R/L-SS 	Light Cutting of Swiss Style Lathes The parallel chip breaker. Excellent chip control at low feed rates.	Carbon Steel • Alloy Steel ap (inch) vs f (IPR) graph  Flank 14° 
Medium Cutting	G	R/L-SN 	Medium Cutting of Swiss Style Lathes The parallel chip breaker. Excellent chip control at low to medium feed rates.	Carbon Steel • Alloy Steel ap (inch) vs f (IPR) graph  Flank 20° 
	G	SMG 	Medium Cutting of Swiss Style Lathes 3D molded chip breaker provides good chip control. G class insert gives sharp cutting action, allowing high precision machining. Breaker geometry appropriate for copying and back turning.	Carbon Steel • Alloy Steel ap (inch) vs f (IPR) graph  Nose 14° Flank 9° 

P

M

TOOLS FOR SMALL PART MACHINING

MS6015

Negative Inserts (With Hole) G Class

Finish		
R/L-FS		
		

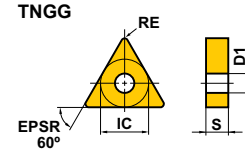

(inch)

Order Number	Cutting Area	Stock		IC	S	RE	D1
		MS6015					
NEW TNGG330.5RFS	F	●		.375	.187	.008	.150
NEW TNGG330.5LFS	F	●		.375	.187	.008	.150
NEW TNGG331RFS	F	●		.375	.187	.016	.150
NEW TNGG331LFS	F	●		.375	.187	.016	.150
NEW TNGG332RFS	F	●		.375	.187	.031	.150
NEW TNGG332LFS	F	●		.375	.187	.031	.150

Recommended Cutting Conditions

(inch)

	Workpiece Material	Grade	Cutting Speed vc (SFM)	Feed f (IPR)
P	Carbon Steels · Alloy Steels	MS6015	330 (165–490)	.0031 (.0004–.0059)
	Pure Irons · Free Cutting Steels		490 (165–820)	.0031 (.0004–.0059)
M	Stainless Steels	MS6015	260 (165–395)	.0024 (.0008–.0039)

* See Index on page 4 for table icon reference. (●, ★, □)

MS6015

7° Positive Inserts (With Hole)

G Class

CCGH
CCGT

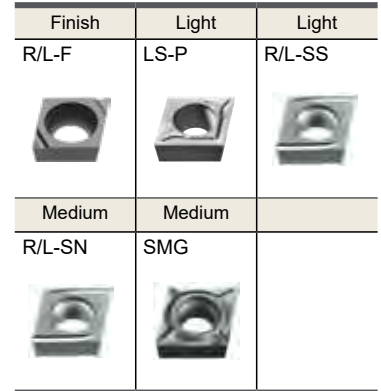
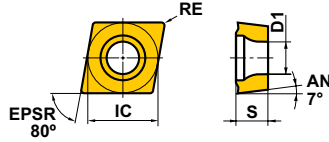

RE : Set the corner radius to a minus tolerance.

Order Number	Cutting Area	Stock		IC	S	RE	D1
		MS6015					
NEW CCGH21.50.5MRF	F	●		.250	.094	.008	.110
NEW CCGH21.50.5MLF	F	●		.250	.094	.008	.110
NEW CCGH21.51MRF	F	●		.250	.094	.016	.110
NEW CCGH21.51MLF	F	●		.250	.094	.016	.110
NEW CCGT03S101MR-F	F	●		.141*	.055	.004	.079
NEW CCGT03S101ML-F	F	●		.141*	.055	.004	.079
NEW CCGT03S102MR-F	F	●		.141*	.055	.008	.079
NEW CCGT03S102ML-F	F	●		.141*	.055	.008	.079
NEW CCGT03S104MR-F	F	●		.141*	.055	.016	.079
NEW CCGT03S104ML-F	F	●		.141*	.055	.016	.079
NEW CCGT04T001MR-F	F	●		.172*	.070	.004	.094
NEW CCGT04T001ML-F	F	●		.172*	.070	.004	.094
NEW CCGT04T002MR-F	F	●		.172*	.070	.008	.094
NEW CCGT04T002ML-F	F	●		.172*	.070	.008	.094
NEW CCGT04T004MR-F	F	●		.172*	.070	.016	.094
NEW CCGT04T004ML-F	F	●		.172*	.070	.016	.094
NEW CCGT21.50.2MLS-P	L	●		.250	.094	.004	.110
NEW CCGT21.50.5MLS-P	L	●		.250	.094	.008	.110
NEW CCGT32.50.2MLS-P	L	●		.375	.156	.004	.173
NEW CCGT32.50.5MLS-P	L	●		.375	.156	.008	.173
NEW CCGT32.51MLS-P	L	●		.375	.156	.016	.173
CCGT21.50.2MRSS	L	●		.250	.094	.004	.110
NEW CCGT21.50.2MLSS	L	●		.250	.094	.004	.110
CCGT21.50.5MRSS	L	●		.250	.094	.008	.110
NEW CCGT21.50.5MLSS	L	●		.250	.094	.008	.110
CCGT32.50.2MRSS	L	●		.375	.156	.004	.173
NEW CCGT32.50.2MLSS	L	●		.375	.156	.004	.173
CCGT32.50.5MRSS	L	●		.375	.156	.008	.173
NEW CCGT32.50.5MLSS	L	●		.375	.156	.008	.173
CCGT32.51MRSS	L	●		.375	.156	.016	.173
NEW CCGT32.51MLSS	L	●		.375	.156	.016	.173

* Diameter of inscribed circle is non-ISO standard. (For SCLC type)

Order Number	Cutting Area	Stock		IC	S	RE	D1
		MS6015					
NEW CCGT21.50.2MRSN	M	●		.250	.094	.004	.110
NEW CCGT21.50.2MLSN	M	●		.250	.094	.004	.110
NEW CCGT21.50.5MRSN	M	●		.250	.094	.008	.110
NEW CCGT21.50.5MLSN	M	●		.250	.094	.008	.110
NEW CCGT32.50.2MRSN	M	●		.375	.156	.004	.173
NEW CCGT32.50.2MLSN	M	●		.375	.156	.004	.173
NEW CCGT32.50.5MRSN	M	●		.375	.156	.008	.173
NEW CCGT32.50.5MLSN	M	●		.375	.156	.008	.173
NEW CCGT32.51MRSN	M	●		.375	.156	.016	.173
NEW CCGT32.51MLSN	M	●		.375	.156	.016	.173
CCGT21.50.2MSMG	M	●		.250	.094	.004	.110
CCGT21.50.5MSMG	M	●		.250	.094	.008	.110
CCGT21.51MSMG	M	●		.250	.094	.016	.110
CCGT32.50.2MSMG	M	●		.375	.156	.004	.173
CCGT32.50.5MSMG	M	●		.375	.156	.008	.173
CCGT32.51MSMG	M	●		.375	.156	.016	.173

(inch)

TOOLS FOR SMALL PART MACHINING

MS6015

7° Positive Inserts (With Hole)

G Class

Light	Light	Medium	Medium
LS-P	R/L-SS	R/L-SN	SMG
			
Finish			
R/L-F			
			

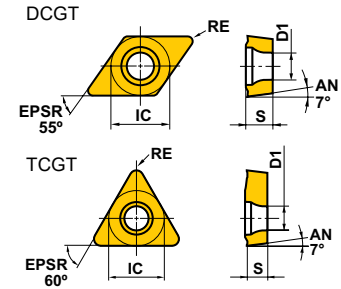

RE : Set the corner radius to a minus tolerance.

Order Number	Cutting Area	Stock		IC	S	RE	D1
		MS6015					
NEW DCGT21.50.2MLS-P	L	●		.250	.094	.004	.110
NEW DCGT21.50.5MLS-P	L	●		.250	.094	.008	.110
NEW DCGT21.51MLS-P	L	●		.250	.094	.016	.110
NEW DCGT32.50.2MLS-P	L	●		.375	.156	.004	.173
NEW DCGT32.50.5MLS-P	L	●		.375	.156	.008	.173
NEW DCGT32.51MLS-P	L	●		.375	.156	.016	.173
DCGT21.50.2MRSS	L	●		.250	.094	.004	.110
NEW DCGT21.50.2MLSS	L	●		.250	.094	.004	.110
DCGT21.50.5MRSS	L	●		.250	.094	.008	.110
NEW DCGT21.50.5MLSS	L	●		.250	.094	.008	.110
DCGT32.50.2MRSS	L	●		.375	.156	.004	.173
NEW DCGT32.50.2MLSS	L	●		.375	.156	.004	.173
DCGT32.50.5MRSS	L	●		.375	.156	.008	.173
NEW DCGT32.50.5MLSS	L	●		.375	.156	.008	.173
DCGT32.51MRSS	L	●		.375	.156	.016	.173
NEW DCGT32.51MLSS	L	●		.375	.156	.016	.173
DCGT21.50.2MRSN	M	●		.250	.094	.004	.110
NEW DCGT21.50.2MLSN	M	●		.250	.094	.004	.110
DCGT21.50.5MRSN	M	●		.250	.094	.008	.110
NEW DCGT21.50.5MLSN	M	●		.250	.094	.008	.110
DCGT32.50.2MRSN	M	●		.375	.156	.004	.173
NEW DCGT32.50.2MLSN	M	●		.375	.156	.004	.173
DCGT32.50.5MRSN	M	●		.375	.156	.008	.173
NEW DCGT32.50.5MLSN	M	●		.375	.156	.008	.173
DCGT32.51MRSN	M	●		.375	.156	.016	.173
NEW DCGT32.51MLSN	M	●		.375	.156	.016	.173
DCGT21.50.2MSMG	M	●		.250	.094	.004	.110
DCGT21.50.5MSMG	M	●		.250	.094	.008	.110
DCGT21.51MSMG	M	●		.250	.094	.016	.110
DCGT32.50.2MSMG	M	●		.375	.156	.004	.173
DCGT32.50.5MSMG	M	●		.375	.156	.008	.173
DCGT32.51MSMG	M	●		.375	.156	.016	.173

(inch)

Order Number	Cutting Area	Stock		IC	S	RE	D1
		MS6015					
NEW TCGT1.210.2MRF	F	●		.156	.063	.004	.091
NEW TCGT1.210.2MLF	F	●		.156	.063	.004	.091
NEW TCGT1.210.5MRF	F	●		.156	.063	.008	.091
NEW TCGT1.210.5MLF	F	●		.156	.063	.008	.091
NEW TCGT1.211MRF	F	●		.156	.063	.016	.091
NEW TCGT1.211MLF	F	●		.156	.063	.016	.091

* See Index on page 4 for table icon reference. (●, ★, □)

BTAH (Inch)

External Back Turning

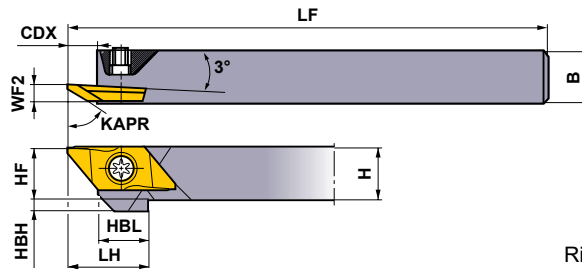
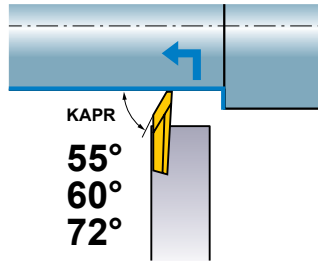

Right hand tool holder shown.

Order Number	Stock		Insert Type	Dimensions (inch)								Clamp Screw *	Wrench			
	R	L		H	B	LF	LH	HF	WF2	HBH	HBL			CDX		
BTAHR/L-062	●	●	BTAT	5528	R/L-B	.375	.375	4.724	.591	.375	.138	.125	.374	.217	NS402W	NKY15S
BTAHR/L-082	●	●		6035	R/L-B	.500	.500	4.724	.591	.500	.138	—	.374	.217	NS403W	NKY15S
BTAHR/L-102	●	●		7235	R-SMB	.625	.625	4.724	.591	.625	.138	—	.374	.217	NS403W	NKY15S

Note 1) Please use right hand insert for right hand holder and left hand insert for left hand holder.

Note 2) Set the maximum depth of cut at under 60% of the effective cutting edge length (LE).

* Clamp Torque (lbf-in) : NS402W=6.2, NS403W=6.2

Inserts

(inch)

Order Number	Hand	Coated			Dimensions						LE*	Geometry
		VP15TF	MS6015	PSIRR/L*	REL	CF	L	W1	CW	S		
NEW BTAT7235V5R-SMB	R	●		72°	.002	.012	.787	.315	.055	.098	.138	With Breaker
NEW BTAT723501MR-SMB	R	●		72°	.003	.012	.787	.315	.055	.098	.138	
NEW BTAT723502MR-SMB	R	●		72°	.007	.012	.787	.315	.055	.098	.138	
BTAT552800R-B	R	●	●	55°	.000	.000	.787	.315	.020	.098	.110	
BTAT552800L-B	L	●		55°	.000	.000	.787	.315	.020	.098	.110	
BTAT552801R-B	R	●	●	55°	.004	.000	.787	.315	.020	.098	.110	
BTAT552801L-B	L	●		55°	.004	.000	.787	.315	.020	.098	.110	
BTAT603500R-B	R	●	●	60°	.000	.000	.787	.315	.020	.098	.138	
BTAT603500L-B	L	●		60°	.000	.000	.787	.315	.020	.098	.138	
NEW BTAT603501MR-B	R	●	●	60°	.003	.000	.787	.315	.020	.098	.138	
BTAT603501R-B	R	●	●	60°	.004	.000	.787	.315	.020	.098	.138	
BTAT603501L-B	L	●		60°	.004	.000	.787	.315	.020	.098	.138	
BTAT605000RX	R	●		60°	.000	.000	.787	.315	.049	.098	.197	Without Breaker

* Numeric value set insert on holder.

CUTTING CONDITIONS > P38

TOOLS FOR SMALL PART MACHINING

P M N

External Back Turning

BTAH (Metric)

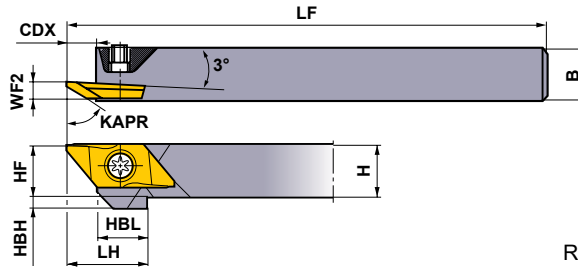
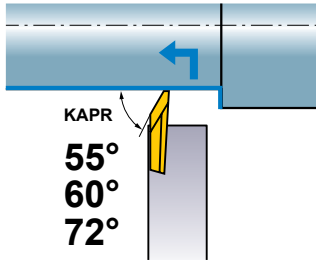

Right hand tool holder shown.

Order Number	Stock		Insert Type	Dimensions (mm)										* Clamp Screw	Wrench		
	R	L		H	B	LF	LH	HF	WF2	HBH	HBL	CDX					
BTAHR/L0810-50	●	●	BTAT	5528	○	R/L-B	8	10	120	15	8	3.5	4	9.5	5.5	NS402W	NKY15S
BTAHR/L1010-50	●	●		6035	○	R/L-B	10	10	120	15	10	3.5	2	9.5	5.5	NS402W	NKY15S
BTAHR/L1212-50	●	●		605000RX			12	12	120	15	12	3.5	—	9.5	5.5	NS403W	NKY15S
BTAHR/L1616-50	●	●		7235	○	R-SMB	16	16	120	15	16	3.5	—	9.5	5.5	NS403W	NKY15S

Note 1) Please use right hand insert for right hand holder and left hand insert for left hand holder.

Note 2) Set the maximum depth of cut at under 60% of the effective cutting edge length (LE).

* Clamp Torque (N • m) : NS402W=1.0, NS403W=1.0

Inserts

(mm)

Order Number	Hand	Coated			Dimensions							LE*	Geometry
		VP15TF	MS6015	PSIRR/L*	REL	CF	L	W1	CW	S			
NEW BTAT7235V5R-SMB	R	●		72°	0.05	0.3	20	8	1.4	2.5	3.5	With Breaker	
NEW BTAT723501MR-SMB	R	●		72°	0.08	0.3	20	8	1.4	2.5	3.5		
NEW BTAT723502MR-SMB	R	●		72°	0.18	0.3	20	8	1.4	2.5	3.5		
BTAT552800R-B	R	●	●	55°	0	0	20	8	0.5	2.5	2.8		
BTAT552800L-B	L	●		55°	0	0	20	8	0.5	2.5	2.8		
BTAT552801R-B	R	●	●	55°	0.1	0	20	8	0.5	2.5	2.8		
BTAT552801L-B	L	●		55°	0.1	0	20	8	0.5	2.5	2.8		
BTAT603500R-B	R	●	●	60°	0	0	20	8	0.5	2.5	3.5		
BTAT603500L-B	L	●		60°	0	0	20	8	0.5	2.5	3.5		
NEW BTAT603501MR-B	R	●	●	60°	0.08	0	20	8	0.5	2.5	3.5		
BTAT603501R-B	R	●	●	60°	0.1	0	20	8	0.5	2.5	3.5		
BTAT603501L-B	L	●		60°	0.1	0	20	8	0.5	2.5	3.5		
BTAT605000RX	R	●		60°	0	0	20	8	1.25	2.5	5.0	Without Breaker	

* Numeric value set insert on holder.

CUTTING CONDITIONS > P39

CTBH (Inch)

External Back Turning

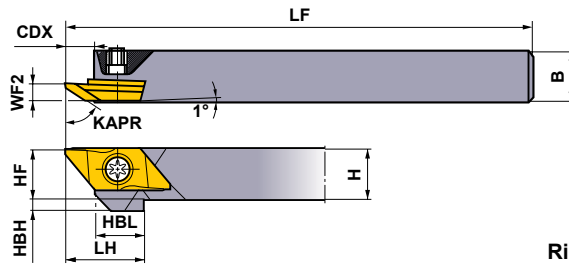
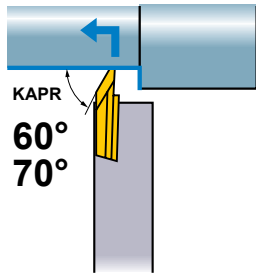

Right hand tool holder shown.

Order Number	Stock		Insert Type	Dimensions (inch)								Clamp Screw *	Wrench		
	R	L		H	B	LF	LH	HF	WF2	HBH	HBL			CDX	
CTBHR/L-062	●	●	BTBT	60450R/L-B	.375	.375	4.724	.768	.375	.133	.125	.472	.295	NS402W	NKY15S
CTBHR/L-082	●	●		606000R/L	.500	.500	4.724	.768	.500	.133	—	.472	.295	NS403W	NKY15S
CTBHR/L-102	●	●		7055R-SMB	.625	.625	4.724	.768	.625	.133	—	.472	.295	NS403W	NKY15S

Note 1) Please use right hand insert for right hand holder and left hand insert for left hand holder.

Note 2) Set the maximum depth of cut at under 60% of the effective cutting edge length (LE).

* Clamp Torque (lbf-in) : NS402W=6.2, NS403W=6.2

Inserts

Order Number	Hand	Coated			Dimensions							LE*	Geometry	
		VP15TF	MS6015	PSIRRL*	REL	CF	L	W1	CW	S	CDX			
NEW BTBT7055V5R-SMB	R	●		70°	.002	.012	.984	.370	.053	.138	.256	.217	<p>With Breaker</p> <p>SMB Type (Pressed Type) B Type (Ground Type)</p> <p>Right hand insert shown.</p>	
NEW BTBT705501MR-SMB	R	●		70°	.003	.012	.984	.370	.053	.138	.256	.217		
NEW BTBT705502MR-SMB	R	●		70°	.007	.012	.984	.370	.053	.138	.256	.217		
BTBT604500R-B	R	●	●	60°	.000	.008	.984	.370	.028	.138	.217	.177		
BTBT604500L-B	L	●		60°	.000	.008	.984	.370	.028	.138	.217	.177		
NEW BTBT604501MR-B	R		●	60°	.003	.012	.984	.370	.028	.138	.217	.177		
BTBT604501R-B	R	●	●	60°	.004	.012	.984	.370	.028	.138	.217	.177		
BTBT604501L-B	L	●		60°	.004	.012	.984	.370	.028	.138	.217	.177		
BTBT606000R	R	●		60°	.000	.008	.984	.370	.028	.138	.276	.236		<p>Without Breaker</p> <p>Right hand insert shown.</p>
BTBT606000L	L	●		60°	.000	.008	.984	.370	.028	.138	.276	.236		

* Numeric value set insert on holder.

Recommended Cutting Conditions

	Workpiece Material	Grade	Cutting Speed vc (SFM)	Feed f (IPR)
P	Carbon Steels · Alloy Steels	VP15TF	165—490	.0004— .006
	Free Cutting Steels	MS6015	100—590	.0004— .006
M	Stainless Steels	VP15TF	165—395	.0008— .004
N	Non-Ferrous Metals	MS6015	230—755	.0012— .006

External Back Turning

CTBH
(Metric)

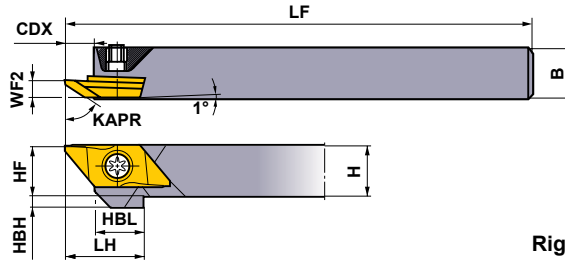
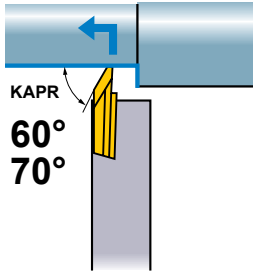

Right hand tool holder shown.

Order Number	Stock		Insert Type	Dimensions (mm)									* Clamp Screw	Wrench			
	R	L		H	B	LF	LH	HF	WF2	HBH	HBL	CDX					
CTBHR/L1010-160	●	●	BTBT	60450	○	R/L-B	10	10	120	19.5	10	3.4	2	12	7.5	NS402W	NKY15S
CTBHR/L1212-160	●	●		606000	○	R/L	12	12	120	19.5	12	3.4	—	12	7.5	NS403W	NKY15S
CTBHR/L1616-160	●	●		7055	○	R-SMB	16	16	120	19.5	16	3.4	—	12	7.5	NS403W	NKY15S

Note 1) Please use right hand insert for right hand holder and left hand insert for left hand holder.

Note 2) Set the maximum depth of cut at under 60% of the effective cutting edge length (LE).

* Clamp Torque (N · m) : NS402W=1.0, NS403W=1.0

Inserts

(mm)

Order Number	Hand	Coated		Dimensions								LE*	Geometry
		VP15TF	MS6015	PSIRRL*	REL	CF	L	W1	CW	S	CDX		
NEW BTBT7055V5R-SMB	R	●		70°	0.05	0.3	25	9.4	1.35	3.5	6.5	5.5	With Breaker
NEW BTBT705501MR-SMB	R	●		70°	0.08	0.3	25	9.4	1.35	3.5	6.5	5.5	
NEW BTBT705502MR-SMB	R	●		70°	0.18	0.3	25	9.4	1.35	3.5	6.5	5.5	
BTBT604500R-B	R	●	●	60°	0	0.2	25	9.4	0.7	3.5	5.5	4.5	SMB Type (Pressed Type) B Type (Ground Type)
BTBT604500L-B	L	●		60°	0	0.2	25	9.4	0.7	3.5	5.5	4.5	
NEW BTBT604501MR-B	R		●	60°	0.08	0.3	25	9.4	0.7	3.5	5.5	4.5	
BTBT604501R-B	R	●	●	60°	0.1	0.3	25	9.4	0.7	3.5	5.5	4.5	
BTBT604501L-B	L	●		60°	0.1	0.3	25	9.4	0.7	3.5	5.5	4.5	
BTBT606000R	R	●		60°	0	0.2	25	9.4	0.7	3.5	7	6.0	
BTBT606000L	L	●		60°	0	0.2	25	9.4	0.7	3.5	7	6.0	Without Breaker

* Numeric value set insert on holder.

Recommended Cutting Conditions

	Workpiece Material	Properties	Grade	Cutting Speed vc (m/min)	Feed f (mm/rev)
P	Carbon Steels · Alloy Steels	180HB-280HB	VP15TF	100 (50-150)	0.08 (0.01-0.15)
	Free Cutting Steels	—	MS6015	110 (30-180)	0.08 (0.01-0.15)
M	Stainless Steels	≤200HB	VP15TF	80 (50-120)	0.06 (0.02-0.1)
N	Non-Ferrous Metals	—	MS6015	150 (70-230)	0.09 (0.03-0.15)

CTAH (Inch)

External Cutting Off

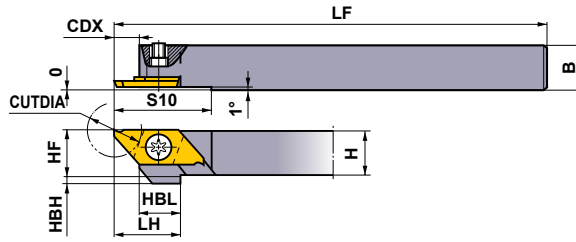
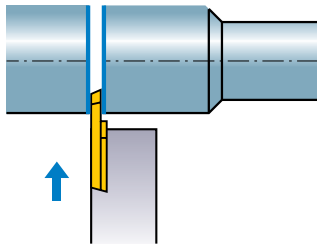

Right hand tool holder shown.

Order Number	Stock		Insert Type	Dimensions (inch)										CUTDIA (inch)	*2	
	R	L		H	B	HF	LF	LH	CDX	HBH	HBL	S10	Clamp Screw		Wrench	
CTAHR/L-062	●	●	CTAT	○○○○	.375	.375	.375	4.724	.591	.217	.125	.374	.866	.472 (.315)*1	NS402W	NKY15S
CTAHR/L-082	●	●		○○○○	.500	.500	.500	4.724	.591	.217	—	.374	.866		NS402W	NKY15S
CTAHR/L-102	●	●		○○○○	.625	.625	.625	4.724	.591	.217	—	.374	.866		NS403W	NKY15S

*1 When the width of cutting off (CW) is .028inch.

*2 Clamp Torque (lbf-in) : NS402W=6.2, NS403W=6.2

CTAH-S

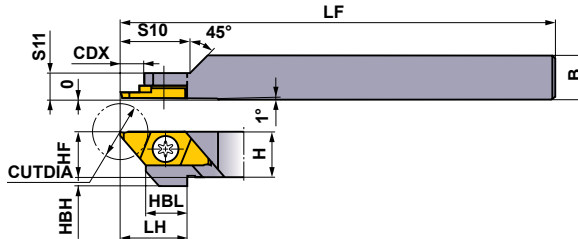
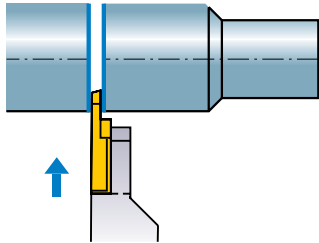

Right hand tool holder only.

Order Number	Stock		Insert Type	Dimensions (inch)											CUTDIA (inch)	*2	
	R	L		H	B	HF	LF	LH	CDX	HBH	HBL	S10	S11	Clamp Screw		Wrench	
CTAHR-062S	●		CTAT	○○○○	.375	.375	.375	3.150	.591	.217	.125	.374	.630	.217	.472 (.315)*1	NS401	NKY25R
CTAHR-082S	●			○○○○	.500	.500	.500	3.150	.591	.217	—	.374	.630	.217		NS401	NKY25R

*1 When the width of cutting off (CW) is .028inch.

*2 Clamp Torque (lbf-in) : NS401=31

Recommended Cutting Conditions

	Workpiece Material	Grade	Cutting Speed vc (SFM)	Feed f (IPR)
P	Carbon Steels · Alloy Steels	VP15TF	165—490	.0008— .0035
	Free Cutting Steels	MS6015	100—590	.0004— .0035
M	Stainless Steels	VP15TF	165—395	.0008— .0019
N	Non-Ferrous Metals	MS6015	230—755	.0012— .0043

Inserts

(inch)

Holder	Setting Geometry	Breaker	Geometry	Insert Geometry	Order Number	Hand	Coated		Dimensions						* CUTDIA	
							VP15TF	MS6015	CW	CDX	RER/L	L	W1	S		LBB
Right Hand (R)		With Breaker		REL	CTAT07080V5RR-B	R	●		.028	.177	.002	.787	.315	.098	.059	.315
				LBB	CTAT10120V5RR-B	R	●	●	.039	.264	.002	.787	.315	.098	.059	.472
	CW			CTAT15120V5RR-B	R	●	●	.059	.264	.002	.787	.315	.098	.059	.472	
	RER			CTAT20120V5RR-B	R	●	●	.079	.264	.002	.787	.315	.098	.059	.472	
	REL			CTAT15120V5RR-BX	R	●		.059	.264	.002	.787	.315	.098	.059	.472	
	LBB			CTAT20120V5RR-BX	R	●		.079	.264	.002	.787	.315	.098	.059	.472	
	CW															
	RER															
	REL			CTAT10120V5RN-B	N	●	●	.039	.264	.002	.787	.315	.098	.059	.472	
	LBB			CTAT15120V5RN-B	N	●	●	.059	.264	.002	.787	.315	.098	.059	.472	
CW	CTAT20120V5RN-B	N	●	●	.079	.264	.002	.787	.315	.098	.059	.472				
RER																
REL	CTAT15120V5RN-BX	N	●		.059	.264	.002	.787	.315	.098	.059	.472				
LBB	CTAT20120V5RN-BX	N	●		.079	.264	.002	.787	.315	.098	.059	.472				
CW																
RER																
REL	CTAT10110V5RL-B	L	●		.039	.264	.002	.787	.315	.098	.059	.433				
LBB	CTAT15110V5RL-B	L	●		.059	.264	.002	.787	.315	.098	.059	.433				
CW	CTAT20110V5RL-B	L	●		.079	.264	.002	.787	.315	.098	.059	.433				
RER																
REL	CTAT1012000RR	R	●	●	.039	.264	.000	.787	.315	.098	.138	.472				
LBB	CTAT1512000RR	R	●	●	.059	.264	.000	.787	.315	.098	.138	.472				
CW	CTAT2012000RR	R	●	●	.079	.264	.000	.787	.315	.098	.138	.472				
RER																
REL	CTAT07080V5LL-B	L	●		.028	.177	.002	.787	.315	.098	.059	.315				
LBB	CTAT10120V5LL-B	L	●		.039	.264	.002	.787	.315	.098	.059	.472				
CW	CTAT15120V5LL-B	L	●		.059	.264	.002	.787	.315	.098	.059	.472				
RER	CTAT20120V5LL-B	L	●		.079	.264	.002	.787	.315	.098	.059	.472				
REL	CTAT10120V5LN-B	N	●	●	.039	.264	.002	.787	.315	.098	.059	.472				
LBB	CTAT15120V5LN-B	N	●	●	.059	.264	.002	.787	.315	.098	.059	.472				
CW	CTAT20120V5LN-B	N	●	●	.079	.264	.002	.787	.315	.098	.059	.472				
RER																
REL	CTAT10110V5LR-B	R	●	●	.039	.264	.002	.787	.315	.098	.059	.433				
LBB	CTAT15110V5LR-B	R	●	●	.059	.264	.002	.787	.315	.098	.059	.433				
CW	CTAT20110V5LR-B	R	●	●	.079	.264	.002	.787	.315	.098	.059	.433				
RER																
REL	CTAT1012000LL	L	●		.039	.264	.000	.787	.315	.098	.138	.472				
LBB	CTAT1512000LL	L	●		.059	.264	.000	.787	.315	.098	.138	.472				
CW	CTAT2012000LL	L	●		.079	.264	.000	.787	.315	.098	.138	.472				
RER																

* CUTDIA : Max. Cut Off Diameter

CTAH (Metric)

External Cutting Off

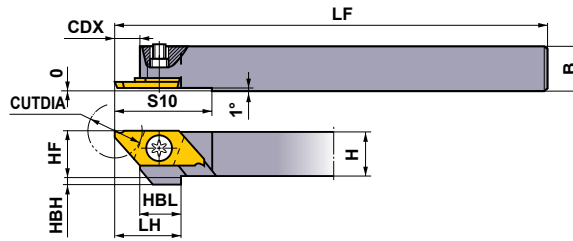
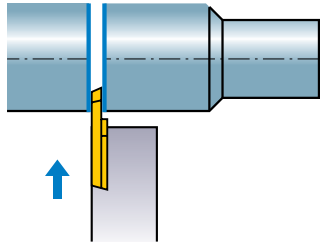

Right hand tool holder shown.

Order Number	Stock		Insert Type	Dimensions (mm)									CUTDIA (mm)	*2 Clamp Screw	 Wrench			
	R	L		H	B	HF	LF	LH	CDX	HBH	HBL	S10						
CTAHR/L0810-120	●	●	CTAT	○ ○ ○ ○	8	10	8	120	15	5.5	4	9.5	22	12 (8)*1	NS402W	NKY15S		
CTAHR/L1010-120	●	●		○ ○ ○ ○	10	10	10	120	15	5.5	2	9.5	22				NS402W	NKY15S
CTAHR/L1212-120	●	●		○ ○ ○ ○	12	12	12	120	15	5.5	—	9.5	22					
CTAHR/L1616-120	●	●		○ ○ ○ ○	16	16	16	120	15	5.5	—	9.5	22				NS403W	NKY15S

*1 When the width of cutting off (CW) is 0.7mm.

*2 Clamp Torque (N • m) : NS402W=1.0, NS403W=1.0

CTAH-S

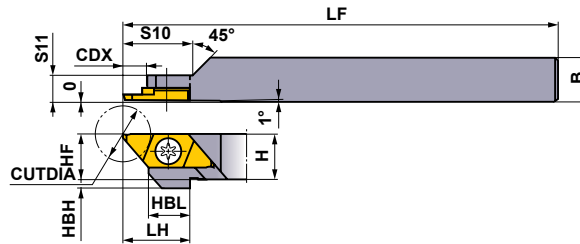
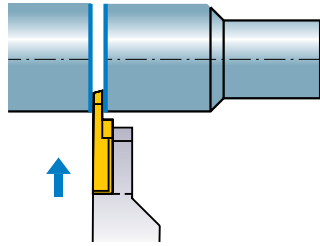

Right hand tool holder only.

Order Number	Stock	Insert Type	Dimensions (mm)										CUTDIA (mm)	*2 Clamp Screw	 Wrench	
	R		H	B	HF	LF	LH	CDX	HBH	HBL	S10	S11				
CTAHR1010-120S	●	CTAT	○ ○ ○ ○	10	10	10	80	15	16	2	9.5	16	5.5	12 (8)*1	NS401	NKY25R

*1 When the width of cutting off (CW) is 0.7mm.

*2 Clamp Torque (N • m) : NS401=3.5

Recommended Cutting Conditions

	Workpiece Material	Properties	Grade	Cutting Speed vc (m/min)	Feed f (mm/rev)
P	Carbon Steels · Alloy Steels	180HB–280HB	VP15TF	100 (50–150)	0.05 (0.02–0.09)
	Free Cutting Steels	—	MS6015	110 (30–180)	0.05 (0.01–0.09)
M	Stainless Steels	≤200HB	VP15TF	80 (50–120)	0.03 (0.02–0.05)
N	Non-Ferrous Metals	—	MS6015	150 (70–230)	0.07 (0.03–0.11)

Inserts (Metric)

(mm)

Holder	Setting Geometry	Breaker	Geometry	Insert Geometry	Order Number	Hand	Coated		Dimensions							* CUTDIA
							VP15TF	MS6015	CW	CDX	RER/L	L	W1	S	LBB	
Right Hand (R)	16°	With Breaker			CTAT07080V5RR-B	R	●		0.7	4.5	0.05	20	8	2.5	1.5	8
					CTAT10120V5RR-B	R	●	●	1.0	6.7	0.05	20	8	2.5	1.5	12
					CTAT15120V5RR-B	R	●	●	1.5	6.7	0.05	20	8	2.5	1.5	12
					CTAT20120V5RR-B	R	●	●	2.0	6.7	0.05	20	8	2.5	1.5	12
	16°				CTAT15120V5RR-BX	R	●		1.5	6.7	0.05	20	8	2.5	1.5	12
					CTAT20120V5RR-BX	R	●		2.0	6.7	0.05	20	8	2.5	1.5	12
	0°				CTAT10120V5RN-B	N	●	●	1.0	6.7	0.05	20	8	2.5	1.5	12
					CTAT15120V5RN-B	N	●	●	1.5	6.7	0.05	20	8	2.5	1.5	12
					CTAT20120V5RN-B	N	●	●	2.0	6.7	0.05	20	8	2.5	1.5	12
					CTAT15120V5RN-BX	N	●		1.5	6.7	0.05	20	8	2.5	1.5	12
	16°				CTAT10110V5RL-B	L	●		1.0	6.7	0.05	20	8	2.5	1.5	11
					CTAT15110V5RL-B	L	●		1.5	6.7	0.05	20	8	2.5	1.5	11
		CTAT20110V5RL-B	L	●		2.0	6.7	0.05	20	8	2.5	1.5	11			
20°		CTAT1012000RR	R	●	●	1.0	6.7	0	20	8	2.5	3.5	12			
		CTAT1512000RR	R	●	●	1.5	6.7	0	20	8	2.5	3.5	12			
		CTAT2012000RR	R	●	●	2.0	6.7	0	20	8	2.5	3.5	12			
Left Hand (L)	16°	With Breaker			CTAT07080V5LL-B	L	●		0.7	4.5	0.05	20	8	2.5	1.5	8
					CTAT10120V5LL-B	L	●		1.0	6.7	0	20	8	2.5	1.5	12
					CTAT15120V5LL-B	L	●		1.5	6.7	0	20	8	2.5	1.5	12
					CTAT20120V5LL-B	L	●		2.0	6.7	0	20	8	2.5	1.5	12
	0°				CTAT10120V5LN-B	N	●	●	1.0	6.7	0.05	20	8	2.5	1.5	12
					CTAT15120V5LN-B	N	●	●	1.5	6.7	0.05	20	8	2.5	1.5	12
					CTAT20120V5LN-B	N	●	●	2.0	6.7	0.05	20	8	2.5	1.5	12
	16°				CTAT10110V5LR-B	R	●	●	1.0	6.7	0.05	20	8	2.5	1.5	11
					CTAT15110V5LR-B	R	●	●	1.5	6.7	0.05	20	8	2.5	1.5	11
					CTAT20110V5LR-B	R	●	●	2.0	6.7	0.05	20	8	2.5	1.5	11
	20°				CTAT1012000LL	L	●		1.0	6.7	0	20	8	2.5	3.5	12
					CTAT1512000LL	L	●		1.5	6.7	0	20	8	2.5	3.5	12
		CTAT2012000LL	L	●		2.0	6.7	0	20	8	2.5	3.5	12			

* CUTDIA : Max. Cut Off Diameter

CTBH

(Inch)

External Cutting Off

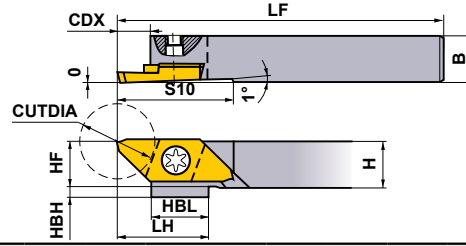
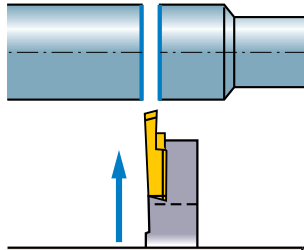

Right hand tool holder shown.

Order Number	Stock		Insert Type	Dimensions (inch)									CUTDIA (inch)	*		
	R	L		H	B	HF	LF	LH	CDX	HBH	HBL	S10		Clamp Screw	Wrench	
CTBHR/L-062	●	●	CTBT	○	.375	.375	.375	4.724	.768	.295	.125	.374	.984	.630	NS402W	NKY15S
CTBHR/L-082	●	●		.500	.500	.500	4.724	.768	.295	—	.374	.984	.630	NS403W	NKY15S	
CTBHR/L-102	●	●		.625	.625	.625	4.724	.768	.295	—	.374	.984	.630	NS403W	NKY15S	

* Clamp Torque (lbf-in) : NS402W=6.2, NS403W=6.2

Inserts

Holder	Setting Geometry	Breaker	Geometry	Insert Geometry	Order Number	Hand	Coated		Dimensions						CUTDIA	
							VP15TF	MS6015	CW	CDX	RER/L	L	W1	S		
Right Hand (R)		With Breaker			CTBT15160V5RR-B	R	●	●	.059	.362	.002	.984	.370	.138	.630	
					CTBT20160V5RR-B	R	●	●	.079	.362	.002	.984	.370	.138	.630	
				CTBT20160V5RN-B	N	●	●	.079	.362	.002	.984	.370	.138	.630		
Left Hand (L)		With Breaker				CTBT20160V5LL-B	L	●		.079	.362	.002	.984	.370	.138	.630
						CTBT20160V5LN-B	N	●		.079	.362	.002	.984	.370	.138	.630
					CTBT20145V5LR-B	R	●	●	.079	.362	.002	.984	.370	.138	.571	

Right hand insert shown.

External Cutting Off

CTBH (Metric)

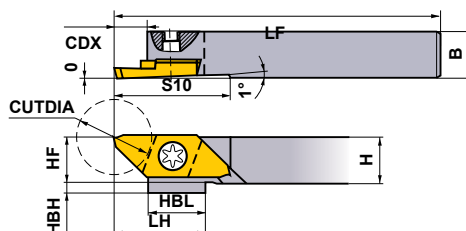
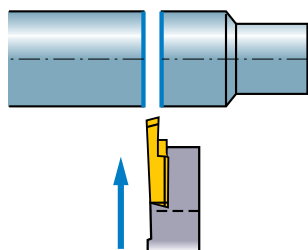

Right hand tool holder shown.

Order Number	Stock		Insert Type	Dimensions (mm)										CUTDIA (mm)	*	
	R	L		H	B	HF	LF	LH	CDX	HBH	HBL	S10	Clamp Screw		Wrench	
CTBHR/L1010-160	●	●	CTBT	10	10	10	120	19.5	7.5	2	9.5	25	16	NS402W	NKY15S	
CTBHR/L1212-160	●	●		12	12	12	120	19.5	7.5	—	9.5	25	16	NS403W	NKY15S	
CTBHR/L1616-160	●	●		16	16	16	120	19.5	7.5	—	9.5	25	16	NS403W	NKY15S	

* Clamp Torque (N • m) : NS402W=1.0, NS403W=1.0

Inserts

Holder	Setting Geometry	Breaker	Geometry	Insert Geometry	Order Number	Hand	Coated		Dimensions						CUTDIA
							VP15TF	MS6015	CW	CDX	RER/L	L	W1	S	
Right Hand (R)	16°	With Breaker			CTBT15160V5RR-B	R	●	●	1.5	9.2	0.05	25	9.4	3.5	16
	0°				CTBT20160V5RR-B	R	●	●	2.0	9.2	0.05	25	9.4	3.5	16
Left Hand (L)	16°				CTBT20160V5RN-B	N	●	●	2.0	9.2	0.05	25	9.4	3.5	16
	0°				CTBT20160V5LL-B	L	●	●	2.0	9.2	0.05	25	9.4	3.5	16
	16°				CTBT20160V5LN-B	N	●	●	2.0	9.2	0.05	25	9.4	3.5	16
	16°				Right hand insert shown.		CTBT20145V5LR-B	R	●	●	2.0	9.2	0.05	25	9.4

* See Index on page 4 for table icon reference. (●, ★, □)

Application Example

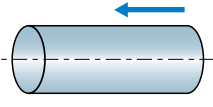
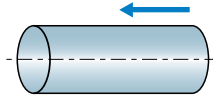
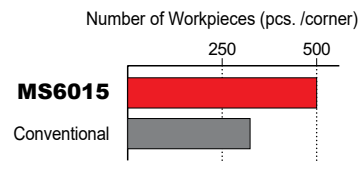
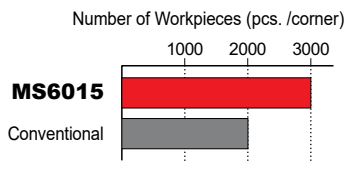
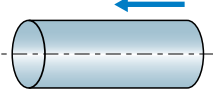
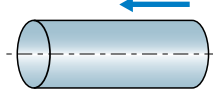
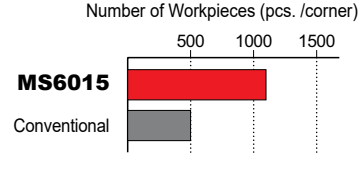
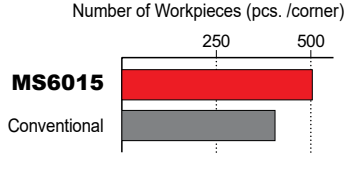
Insert (Grade)		DCGT32.50.5MSMG (MS6015)	DCGT32.50.2MRSN (MS6015)
Workpiece		Iron-based Soft Magnetic Material (ELCH2) 	Free Cutting Steel (AISI 12L14) 
	Cutting Conditions		
	Cutting Speed v_c (SFM)	645 (4500min ⁻¹)	410 (5000min ⁻¹)
	Feed per Rev. f (IPR)	.004	.002
	Depth of Cut a_p (inch)	.004	.012
Cutting Mode		Wet Cutting (Water-insoluble)	Wet Cutting (Water-insoluble)
Machine		Swiss Style Lathes	Swiss Style Lathes
Results		<p>Number of Workpieces (pcs. /corner)</p>  <p>MS6015</p> <p>Conventional</p> <p>An excellent finished surface and 1.4X longer life compared with conventional products. Stable SMG breaker and chip discharge management.</p>	<p>Number of Workpieces (pcs. /corner)</p>  <p>MS6015</p> <p>Conventional</p> <p>MS6015 has minimal welding and maintains secure dimensional accuracy.</p>
Insert (Grade)		DCGT32.50.5MRSN (MS6015)	DCGT32.50.5MSMG (MS6015)
Workpiece		Carbon Steel (AISI 1045) 	Mild Steel (AISI 1015) 
	Cutting Conditions		
	Cutting Speed v_c (SFM)	370 (3000min ⁻¹)	330 (1300min ⁻¹)
	Feed per Rev. f (IPR)	.001	.005
	Depth of Cut a_p (inch)	.039	.051
Cutting Mode		Wet Cutting (Water-insoluble)	Wet Cutting (Water-insoluble)
Machine		Swiss Style Lathes	Swiss Style Lathes
Results		<p>Number of Workpieces (pcs. /corner)</p>  <p>MS6015</p> <p>Conventional</p> <p>MS6015 has superior wear resistance and achieves 2X longer life compared with conventional products.</p>	<p>Number of Workpieces (pcs. /corner)</p>  <p>MS6015</p> <p>Conventional</p> <p>MS6015 has superior welding resistance and achieves 1.3X longer life compared with conventional products.</p>



Product Extension

DIA  **EDGE**

FP BREAKER

BETTER CHOICE for
Steel finish cutting

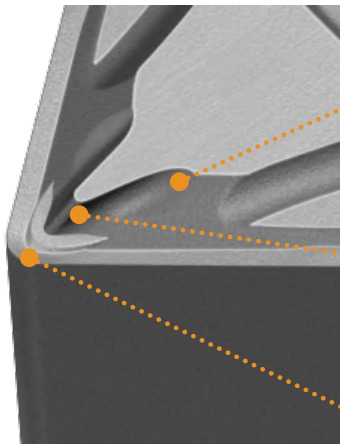
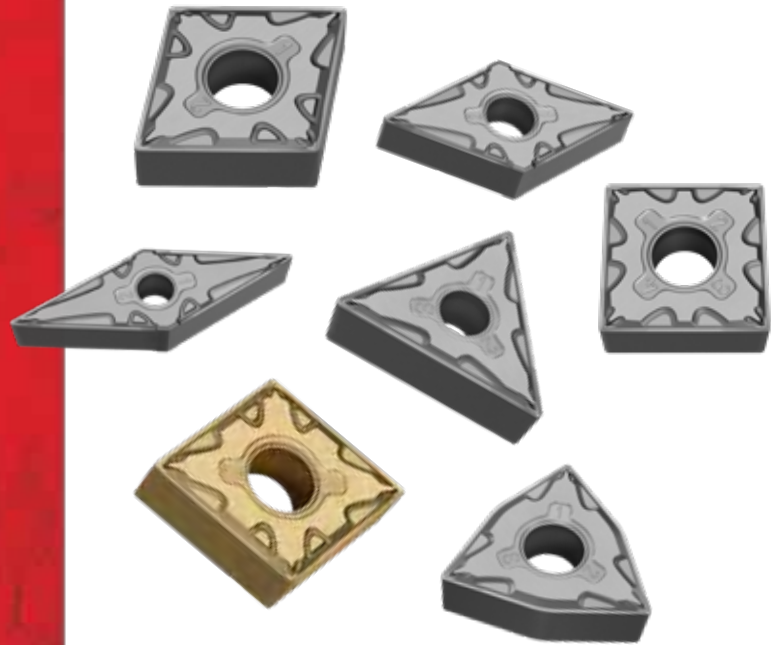

Stable Chip Control in Wide Range

1st and 2nd convex and recess geometry provide stable chip control. 1st convex provides excellent chip control in low feed rates.

Available to Both General and Low Carbon Steel Cutting

2nd convex is effective for chip control of soft materials.

A Good Surface Finish Through the 20° Positive High Rake Angle



Negative Inserts (With Hole) M Class

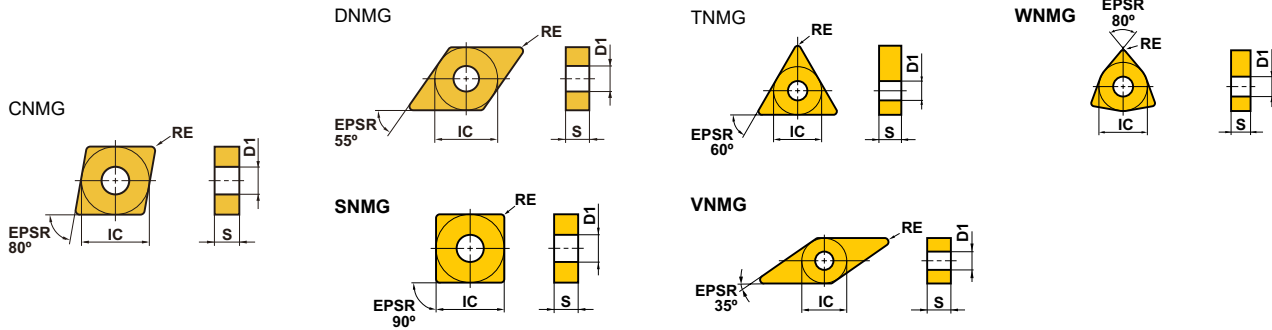

Order Number	Cutting Area	MP3025	NX2525	IC	S	RE	D1
CNMG430.5FP	F	●	★	.500	.187	.008	.203
CNMG431FP	F	●	★	.500	.187	.016	.203
CNMG432FP	F	●	★	.500	.187	.031	.203
NEW CNMG433FP	F	●	★	.500	.187	.047	.203
DNMG430.5FP	F	●	★	.500	.187	.008	.203
DNMG431FP	F	●	★	.500	.187	.016	.203
DNMG432FP	F	●	★	.500	.187	.031	.203
NEW DNMG433FP	F	●	★	.500	.187	.047	.203
DNMG440.5FP	F	●	★	.500	.250	.008	.203
DNMG441FP	F	●	★	.500	.250	.016	.203
DNMG442FP	F	●	★	.500	.250	.031	.203
NEW DNMG443FP	F	●	★	.500	.250	.047	.203
SNMG431FP	F	●	★	.500	.187	.016	.203
SNMG432FP	F	●	★	.500	.187	.031	.203
NEW SNMG433FP	F	●	★	.500	.187	.047	.203

Order Number	Cutting Area	MP3025	NX2525	IC	S	RE	D1
TNMG330.5FP	F	●	★	.375	.187	.008	.150
TNMG331FP	F	●	★	.375	.187	.016	.150
TNMG332FP	F	●	★	.375	.187	.031	.150
NEW TNMG333FP	F	●	★	.375	.187	.047	.150
VNMG330.5FP	F	●	★	.375	.187	.008	.150
VNMG331FP	F	●	★	.375	.187	.016	.150
VNMG332FP	F	●	★	.375	.187	.031	.150
NEW VNMG333FP	F	●	★	.375	.187	.047	.150
WNMG430.5FP	F	●	★	.500	.187	.008	.203
WNMG431FP	F	●	★	.500	.187	.016	.203
WNMG432FP	F	●	★	.500	.187	.031	.203
NEW WNMG433FP	F	●	★	.500	.187	.047	.203

Recommended Cutting Conditions

Work Material	Properties	Cutting Area	Cutting Conditions	Grade	Chip Breaker	vc (SFM)	f (IPR)	ap
P Carbon Steels • Alloy Steels	180—280HB	Finish Cutting	Stable Cutting	NX2525	FP	690—985	.003—.010	.004—.039
			General Cutting	MP3025	FP	705—1080	.003—.010	.004—.039

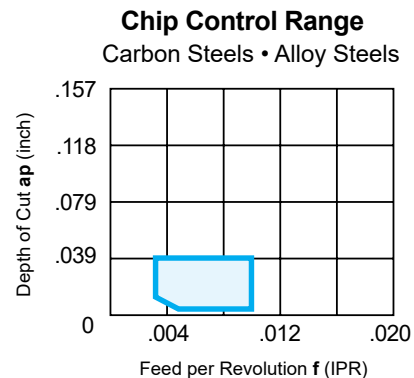
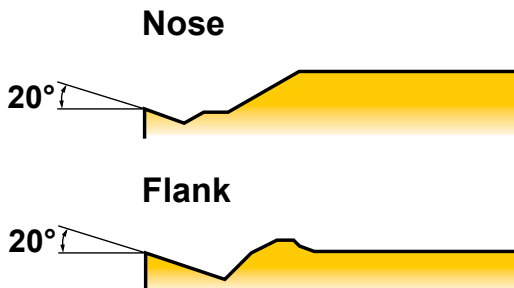

* See Index on page 4 for table icon reference. (●, ★, □)

Product Extension

DIA  **EDGE**

6000 SERIES



Pushing the boundaries
of steel turning



Negative Inserts (With Hole) M Class

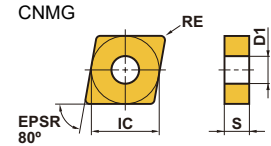
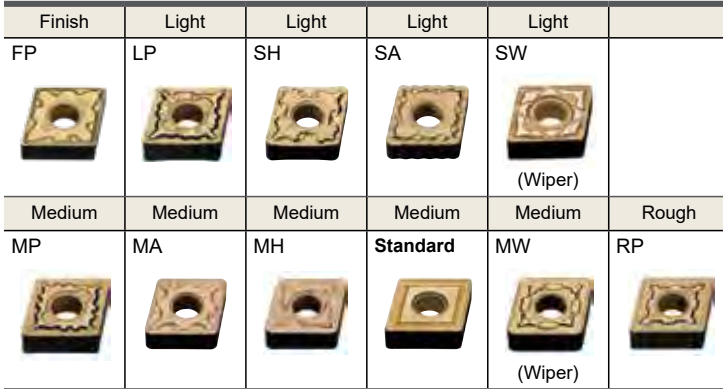

Order Number	Cutting Area				IC	S	RE	D1
		MC6015	MC6025	MC6035				
CNMG430.5FP	F	●	●		.500	.187	.008	.203
CNMG431FP	F	●	●		.500	.187	.016	.203
CNMG432FP	F	●	●		.500	.187	.031	.203
NEW CNMG433FP	F	●	●		.500	.187	.047	.203
CNMG431LP	L	●	●	●	.500	.187	.016	.203
CNMG432LP	L	●	●	●	.500	.187	.031	.203
CNMG433LP	L	●	●	●	.500	.187	.047	.203
CNMG431SH	L	●	●		.500	.187	.016	.203
CNMG432SH	L	●	●		.500	.187	.031	.203
CNMG433SH	L	●	●		.500	.187	.047	.203
CNMG431SA	L	●	●		.500	.187	.016	.203
CNMG432SA	L	●	●		.500	.187	.031	.203
CNMG433SA	L	●	●		.500	.187	.047	.203
CNMG431SW	L	●			.500	.187	.016	.203
CNMG432SW	L	●			.500	.187	.031	.203
CNMG433SW	L	●			.500	.187	.047	.203

Order Number	Cutting Area				IC	S	RE	D1
		MC6015	MC6025	MC6035				
CNMG431MP	M	●	●	●	.500	.187	.016	.203
CNMG432MP	M	●	●	●	.500	.187	.031	.203
CNMG433MP	M	●	●	●	.500	.187	.047	.203
CNMG434MP	M	●	●	●	.500	.187	.063	.203
CNMG542MP	M		●		.625	.250	.031	.250
CNMG543MP	M		●		.625	.250	.047	.250
CNMG544MP	M		●		.625	.250	.063	.250
CNMG431MA	M	●	●		.500	.187	.016	.203
CNMG432MA	M	●	●	●	.500	.187	.031	.203
CNMG433MA	M	●	●	●	.500	.187	.047	.203
CNMG542MA	M	●	●	●	.625	.250	.031	.250
CNMG543MA	M	●	●	●	.625	.250	.047	.250
CNMG544MA	M	●	●	●	.625	.250	.063	.250
CNMG643MA	M	●	●	●	.750	.250	.047	.312
CNMG644MA	M	●	●	●	.750	.250	.063	.312
CNMG432MH	M	●	●	●	.500	.187	.031	.203
CNMG433MH	M	●	●	●	.500	.187	.047	.203
CNMG543MH	M	●	●	●	.625	.250	.047	.250
CNMG643MH	M	●	●	●	.750	.250	.047	.312
CNMG32.51	M	★	★		.375	.156	.016	.150
CNMG32.52	M	★	★		.375	.156	.031	.150
CNMG431	M	●	●		.500	.187	.016	.203
CNMG432	M	●	●	●	.500	.187	.031	.203
CNMG433	M	●	●	●	.500	.187	.047	.203
CNMG434	M	●	●		.500	.187	.063	.203
CNMG542	M	●	●	●	.625	.250	.031	.250
CNMG543	M	●	●	●	.625	.250	.047	.250
CNMG544	M	●	●	●	.625	.250	.063	.250
CNMG642	M	●	●	●	.750	.250	.031	.312
CNMG643	M	●	●	●	.750	.250	.047	.312
CNMG644	M	●	●	●	.750	.250	.063	.312
CNMG432MW	M	●	●		.500	.187	.031	.203
CNMG433MW	M	●	●		.500	.187	.047	.203
CNMG432RP	R	●	●	●	.500	.187	.031	.203
CNMG433RP	R	●	●	●	.500	.187	.047	.203
CNMG434RP	R	●	●	●	.500	.187	.063	.203
CNMG543RP	R	●	●	●	.625	.250	.047	.250
CNMG544RP	R	●	●	●	.625	.250	.063	.250
CNMG643RP	R	●	●	●	.750	.250	.047	.312
CNMG644RP	R	●	●	●	.750	.250	.063	.312

* See Index on page 4 for table icon reference. (●, ★, □)

Negative Inserts (With Hole)



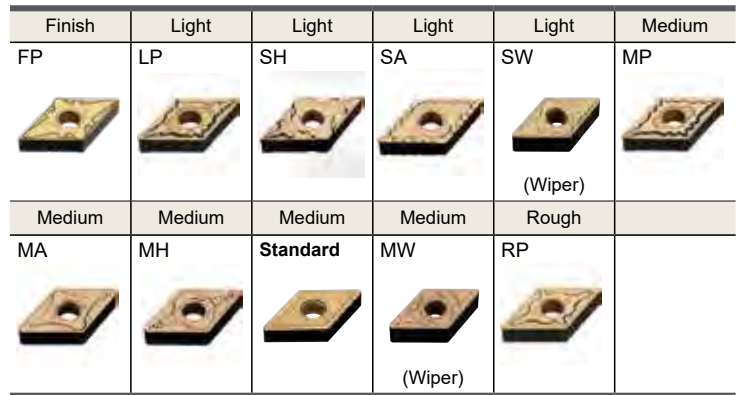
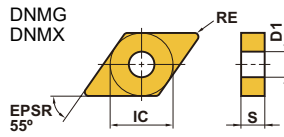





M Class



								(inch)									
Order Number	Cutting Area	MC6015	MC6025	MC6035	IC	S	RE	D1	Order Number	Cutting Area	MC6015	MC6025	MC6035	IC	S	RE	D1
DNMG431FP	F	●	●		.500	.187	.016	.203	DNMG432MP	M	●	●	●	.500	.187	.031	.203
DNMG432FP	F	●	●		.500	.187	.031	.203	DNMG433MP	M	●	●	●	.500	.187	.047	.203
NEW DNMG433FP	F	●	●		.500	.187	.047	.203	DNMG434MP	M	●	●	●	.500	.187	.063	.203
DNMG440.5FP	F	●	●		.500	.250	.008	.203	DNMG441MP	M	●	●	●	.500	.250	.016	.203
DNMG441FP	F	●	●		.500	.250	.016	.203	DNMG442MP	M	●	●	●	.500	.250	.031	.203
DNMG442FP	F	●	●		.500	.250	.031	.203	DNMG443MP	M	●	●	●	.500	.250	.047	.203
NEW DNMG443FP	F	●	●		.500	.250	.047	.203	DNMG444MP	M	●	●	●	.500	.250	.063	.203
DNMG331LP	L	●	●	●	.375	.187	.016	.150	DNMG331MA	M	●	●		.375	.187	.016	.150
DNMG332LP	L	●	●	●	.375	.187	.031	.150	DNMG332MA	M	●	●		.375	.187	.031	.150
DNMG431LP	L	●	●	●	.500	.187	.016	.203	DNMG333MA	M	●	●		.375	.187	.047	.150
DNMG432LP	L	●	●	●	.500	.187	.031	.203	DNMG431MA	M	●	●		.500	.187	.016	.203
DNMG433LP	L	●	●	●	.500	.187	.047	.203	DNMG432MA	M	●	●	●	.500	.187	.031	.203
DNMG441LP	L	●	●	●	.500	.250	.016	.203	DNMG433MA	M	●	●	●	.500	.187	.047	.203
DNMG442LP	L	●	●	●	.500	.250	.031	.203	DNMG441MA	M	●	●		.500	.250	.016	.203
DNMG443LP	L	●	●	●	.500	.250	.047	.203	DNMG442MA	M	●	●	●	.500	.250	.031	.203
DNMG431SH	L	●	●		.500	.187	.016	.203	DNMG443MA	M	●	●	●	.500	.250	.047	.203
DNMG432SH	L	●	●		.500	.187	.031	.203	DNMG432MH	M	●	●	●	.500	.187	.031	.203
DNMG433SH	L	●	●		.500	.187	.047	.203	DNMG433MH	M	●	●	●	.500	.187	.047	.203
DNMG431SA	L	●	●		.500	.187	.016	.203	DNMG442MH	M	●	●	●	.500	.250	.031	.203
DNMG432SA	L	●	●		.500	.187	.031	.203	DNMG443MH	M	●	●	●	.500	.250	.047	.203
DNMG433SA	L	●	●		.500	.187	.047	.203	DNMG431	M	●	●		.500	.187	.016	.203
DNMX331SW	L	●			.375	.187	.016	.150	DNMG432	M	●	●	●	.500	.187	.031	.203
DNMX332SW	L	●			.375	.187	.031	.150	DNMG433	M	●	●	●	.500	.187	.047	.203
DNMX431SW	L	●			.500	.187	.016	.203	DNMG434	M	●	●	●	.500	.187	.063	.203
DNMX432SW	L	●			.500	.187	.031	.203	DNMG441	M	●	●		.500	.250	.016	.203
DNMX433SW	L	●			.500	.187	.047	.203	DNMG442	M	●	●	●	.500	.250	.031	.203
DNMX441SW	L	●			.500	.250	.016	.203	DNMG443	M	●	●	●	.500	.250	.047	.203
DNMX442SW	L	●			.500	.250	.031	.203	DNMG444	M	●	●	●	.500	.250	.063	.203
DNMX443SW	L	●			.500	.250	.047	.203	DNMX432MW	M	●			.500	.187	.031	.203
									DNMX433MW	M	●			.500	.187	.047	.203
									DNMX442MW	M	●			.500	.250	.031	.203
									DNMX443MW	M	●			.500	.250	.047	.203
									DNMG432RP	R	●	●	●	.500	.187	.031	.203
									DNMG433RP	R	●	●	●	.500	.187	.047	.203
									DNMG434RP	R	●	●	●	.500	.187	.063	.203
									DNMG442RP	R	●	●	●	.500	.250	.031	.203
									DNMG443RP	R	●	●	●	.500	.250	.047	.203
									DNMG444RP	R	●	●	●	.500	.250	.063	.203

Negative Inserts (With Hole)

M Class

Medium	Finish	Light	Medium	Medium
Standard	FP	LP	MP	MA
				
Medium	Medium	Rough		
MH	Standard	RP		
				

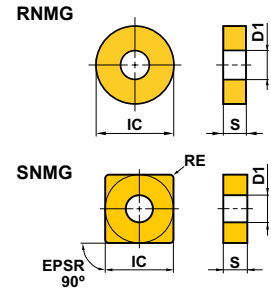

Order Number	Cutting Area				IC	S	RE	D1
		MC6015	MC6025	MC6035				
RNMG43	M	●	●		.500	.187	—	.203

Order Number	Cutting Area				IC	S	RE	D1
		MC6015	MC6025	MC6035				
SNMG431FP	F	●	●		.500	.187	.016	.203
SNMG432FP	F	●	●		.500	.187	.031	.203
NEW SNMG433FP	F	●	●		.500	.187	.047	.203
SNMG431LP	L	●	●	●	.500	.187	.016	.203
SNMG432LP	L	●	●	●	.500	.187	.031	.203
SNMG433LP	L	●	●	●	.500	.187	.047	.203
SNMG431MP	M	●	●	●	.500	.187	.016	.203
SNMG432MP	M	●	●	●	.500	.187	.031	.203
SNMG433MP	M	●	●	●	.500	.187	.047	.203
SNMG431MA	M	●	●		.500	.187	.016	.203
SNMG432MA	M	●	●	●	.500	.187	.031	.203
SNMG433MA	M	●	●	●	.500	.187	.047	.203
SNMG543MA	M	●	●	●	.625	.250	.047	.250
SNMG544MA	M	●	●	●	.625	.250	.063	.250
SNMG643MA	M	●	●	●	.750	.250	.047	.312
SNMG644MA	M	●	●	●	.750	.250	.063	.312
SNMG432MH	M	●	●	●	.500	.187	.031	.203
SNMG433MH	M	●	●	●	.500	.187	.047	.203
SNMG321	M	●	●		.375	.125	.016	.150
SNMG322	M	●	●		.375	.125	.031	.150
SNMG431	M	●	●		.500	.187	.016	.203
SNMG432	M	●	●	●	.500	.187	.031	.203
SNMG433	M	●	●	●	.500	.187	.047	.203
SNMG434	M	●	●	●	.500	.187	.063	.203
SNMG435	M	●	●	●	.500	.187	.079	.203
SNMG543	M	●	●	●	.625	.250	.047	.250
SNMG544	M	●	●	●	.625	.250	.063	.250
SNMG643	M	●	●	●	.750	.250	.047	.312
SNMG644	M	●	●	●	.750	.250	.063	.312
SNMG432RP	R	●	●	●	.500	.187	.031	.203
SNMG433RP	R	●	●	●	.500	.187	.047	.203
SNMG434RP	R	●	●	●	.500	.187	.063	.203
SNMG543RP	R	●	●	●	.625	.250	.047	.250
SNMG544RP	R	●	●	●	.625	.250	.063	.250
SNMG643RP	R	●	●	●	.750	.250	.047	.312
SNMG644RP	R	●	●	●	.750	.250	.063	.312

* See Index on page 4 for table icon reference. (●, ★, □)

Negative Inserts (With Hole)

M Class

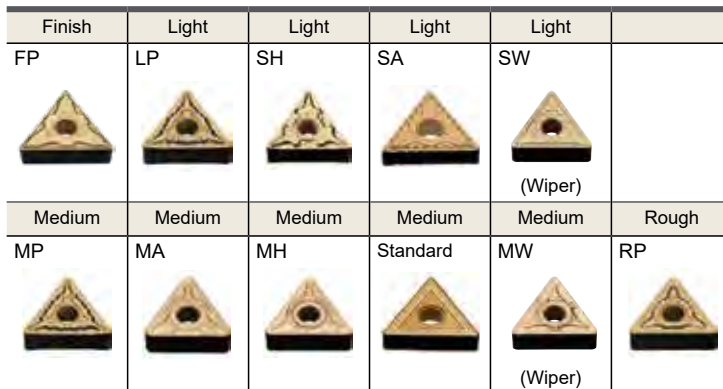
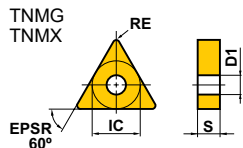









Order Number	Cutting Area	Cutting Area			IC	S	RE	D1
		MC6015	MC6025	MC6035				
TNMG330.5FP	F	●	●		.375	.187	.008	.150
TNMG331FP	F	●	●		.375	.187	.016	.150
TNMG332FP	F	●	●		.375	.187	.031	.150
NEW TNMG333FP	F	●	●		.375	.187	.047	.150
TNMG331LP	L	●	●	●	.375	.187	.016	.150
TNMG332LP	L	●	●	●	.375	.187	.031	.150
TNMG333LP	L	●	●	●	.375	.187	.047	.150
TNMG432LP	L	●	●	●	.500	.187	.031	.203
TNMG433LP	L	●	●	●	.500	.187	.047	.203
TNMG331SH	L	●	●		.375	.187	.016	.150
TNMG332SH	L	●	●		.375	.187	.031	.150
TNMG331SA	L	●	●		.375	.187	.016	.150
TNMG332SA	L	●	●		.375	.187	.031	.150
TNMG331SW	L	●			.375	.187	.016	.150
TNMG332SW	L	●			.375	.187	.031	.150

(inch)

Order Number	Cutting Area	Cutting Area			IC	S	RE	D1
		MC6015	MC6025	MC6035				
TNMG331MP	M	●	●	●	.375	.187	.016	.150
TNMG332MP	M	●	●	●	.375	.187	.031	.150
TNMG333MP	M	●	●	●	.375	.187	.047	.150
TNMG432MP	M	●	●	●	.500	.187	.031	.203
TNMG433MP	M	●	●	●	.500	.187	.047	.203
TNMG331MA	M	●	●		.375	.187	.016	.150
TNMG332MA	M	●	●	●	.375	.187	.031	.150
TNMG333MA	M	●	●	●	.375	.187	.047	.150
TNMG432MA	M	●	●	●	.500	.187	.031	.203
TNMG433MA	M	●	●	●	.500	.187	.047	.203
TNMG332MH	M	●	●	●	.375	.187	.031	.150
TNMG333MH	M	●	●	●	.375	.187	.047	.150
TNMG432MH	M	●	●	●	.500	.187	.031	.203
TNMG433MH	M	●	●	●	.500	.187	.047	.203
TNMG221	M	●	●		.250	.125	.016	.089
TNMG222	M	●	●		.250	.125	.031	.089
TNMG321	M	●	●		.375	.125	.016	.150
TNMG322	M	●	●		.375	.125	.031	.150
TNMG331	M	●	●		.375	.187	.016	.150
TNMG332	M	●	●	●	.375	.187	.031	.150
TNMG333	M	●	●	●	.375	.187	.047	.150
TNMG334	M	●	●	●	.375	.187	.063	.150
TNMG431	M	●	●	●	.500	.187	.016	.203
TNMG432	M	●	●	●	.500	.187	.031	.203
TNMG433	M	●	●	●	.500	.187	.047	.203
TNMG434	M	●	●	●	.500	.187	.063	.203
TNMG542	M	●	●	●	.625	.250	.031	.250
TNMG543	M	●	●	●	.625	.250	.047	.250
TNMG332MW	M	●			.375	.187	.031	.150
TNMG333MW	M	●			.375	.187	.047	.150
TNMG332RP	R	●	●	●	.375	.187	.031	.150
TNMG333RP	R	●	●	●	.375	.187	.047	.150
TNMG432RP	R	●	●	●	.500	.187	.031	.203
TNMG433RP	R	●	●	●	.500	.187	.047	.203
TNMG434RP	R	●	●	●	.500	.187	.063	.203
TNMG543RP	R	●	●	●	.625	.250	.047	.250
TNMG544RP	R	●	●	●	.625	.250	.063	.250

Negative Inserts (With Hole) M Class

Finish	Light	Light	Light
FP	LP	SH	SA
			
Medium	Medium	Medium	Medium
MP	MA	MH	Standard
			

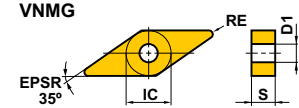

Order Number	Cutting Area	MC			IC	S	RE	D1
		6015	6025	6035				
VNMG330.5FP	F	●	●		.375	.187	.008	.150
VNMG331FP	F	●	●		.375	.187	.016	.150
VNMG332FP	F	●	●		.375	.187	.031	.150
NEW VNMG333FP	F	●	●		.375	.187	.047	.150
VNMG331LP	L	●	●	●	.375	.187	.016	.150
VNMG332LP	L	●	●	●	.375	.187	.031	.150
VNMG331SH	L	●	●		.375	.187	.016	.150
VNMG332SH	L	●	●		.375	.187	.031	.150
VNMG331SA	L	●	●		.375	.187	.016	.150
VNMG332SA	L	●	●		.375	.187	.031	.150

(inch)

Order Number	Cutting Area	MC			IC	S	RE	D1
		6015	6025	6035				
VNMG331MP	M	●	●	●	.375	.187	.016	.150
VNMG332MP	M	●	●	●	.375	.187	.031	.150
VNMG333MP	M	●	●	●	.375	.187	.047	.150
VNMG331MA	M	●	●		.375	.187	.016	.150
VNMG332MA	M	●	●	●	.375	.187	.031	.150
VNMG332MH	M	●	●	●	.375	.187	.031	.150
VNMG331	M	●	●		.375	.187	.016	.150
VNMG332	M	●	●	●	.375	.187	.031	.150
VNMG333	M	●	●	●	.375	.187	.047	.150

* See Index on page 4 for table icon reference. (●, ★, □)

Negative Inserts (With Hole) M Class

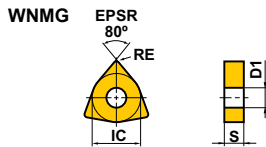

(inch)

Order Number	Cutting Area	MC6015	MC6025	MC6035	IC	S	RE	D1
WNMG430.5FP	F	●	●		.500	.187	.008	.203
WNMG431FP	F	●	●		.500	.187	.016	.203
WNMG432FP	F	●	●		.500	.187	.031	.203
NEW WNMG433FP	F	●	●		.500	.187	.047	.203
WNMG32.51LP	L	●	●	●	.375	.156	.016	.150
WNMG32.52LP	L	●	●	●	.375	.156	.031	.150
WNMG331LP	L	●	●	●	.375	.187	.016	.150
WNMG332LP	L	●	●	●	.375	.187	.031	.150
WNMG431LP	L	●	●	●	.500	.187	.016	.203
WNMG432LP	L	●	●	●	.500	.187	.031	.203
WNMG433LP	L	●	●	●	.500	.187	.047	.203
WNMG431SH	L	●	●		.500	.187	.016	.203
WNMG432SH	L	●	●		.500	.187	.031	.203
WNMG433SH	L	●	●		.500	.187	.047	.203
WNMG431SA	L	●	●		.500	.187	.016	.203
WNMG432SA	L	●	●		.500	.187	.031	.203
WNMG433SA	L	●	●		.500	.187	.047	.203
WNMG331SW	L	●			.375	.187	.016	.150
WNMG332SW	L	●			.375	.187	.031	.150
WNMG431SW	L	●			.500	.187	.016	.203
WNMG432SW	L	●			.500	.187	.031	.203
WNMG433SW	L	●			.500	.187	.047	.203

Order Number	Cutting Area	MC6015	MC6025	MC6035	IC	S	RE	D1
WNMG32.51MP	M	●	●	●	.375	.156	.016	.150
WNMG32.52MP	M	●	●	●	.375	.156	.031	.150
WNMG32.53MP	M	●	●	●	.375	.156	.047	.150
WNMG331MP	M	●	●	●	.375	.187	.016	.150
WNMG332MP	M	●	●	●	.375	.187	.031	.150
WNMG333MP	M	●	●	●	.375	.187	.047	.150
WNMG431MP	M	●	●	●	.500	.187	.016	.203
WNMG432MP	M	●	●	●	.500	.187	.031	.203
WNMG433MP	M	●	●	●	.500	.187	.047	.203
WNMG434MP	M	●	●	●	.500	.187	.063	.203
WNMG331MA	M	●	●		.375	.187	.016	.150
WNMG332MA	M	●	●		.375	.187	.031	.150
WNMG333MA	M	●	●		.375	.187	.047	.150
WNMG431MA	M	●	●		.500	.187	.016	.203
WNMG432MA	M	●	●	●	.500	.187	.031	.203
WNMG433MA	M	●	●	●	.500	.187	.047	.203
WNMG432MH	M	●	●	●	.500	.187	.031	.203
WNMG433MH	M	●	●	●	.500	.187	.047	.203
WNMG431	M	●	●		.500	.187	.016	.203
WNMG432	M	●	●	●	.500	.187	.031	.203
WNMG433	M	●	●	●	.500	.187	.047	.203
WNMG332MW	M	●	●		.375	.187	.031	.150
WNMG333MW	M	●	●		.375	.187	.047	.150
WNMG432MW	M	●	●		.500	.187	.031	.203
WNMG433MW	M	●	●		.500	.187	.047	.203
WNMG432RP	R	●	●	●	.500	.187	.031	.203
WNMG433RP	R	●	●	●	.500	.187	.047	.203

CBN & PCD

TURNING

Inserts



CBN/PCD
Turning Inserts

New Product

DIA  EDGE

MB4120



Improve Productivity with
excellent fracture
resistance & stable cutting

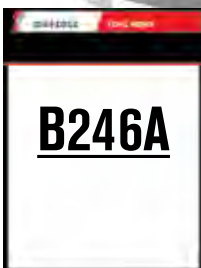

CBN Grade for Sintered Alloys and Cast Irons

Increasing the CBN particle content and bonding strength makes it suitable for machining various sintered materials.

High Fracture Resistance

Fine CBN particles increase cutting edge toughness. The high fracture resistance allows stable performance even during interrupted machining.

High Adhesion Strength of Fine CBN Particles

Optimization of the sintering conditions strengthens adhesion between fine CBN particles. This increases both fracture resistance and wear resistance.

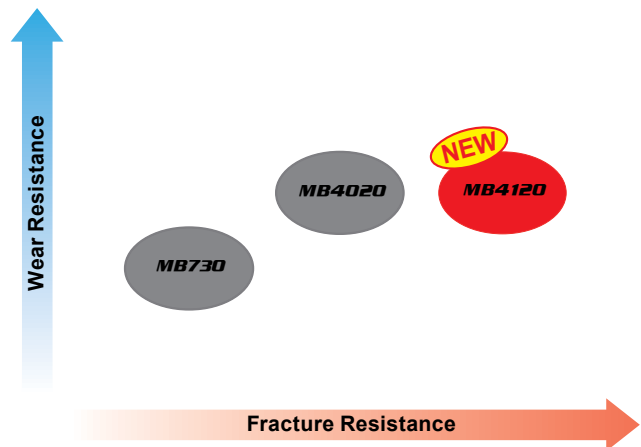

A Wide Range of Edge Preparation (Honing) are Available

The SF type offers a sharper cutting edge, leading to the reduction in cutting resistance and burr development and an increase in surface finishes. The SF type is the first recommendation but, to increase cutting edge strength and chipping resistance there are also the SE, FS, GS and TS edge preparations.

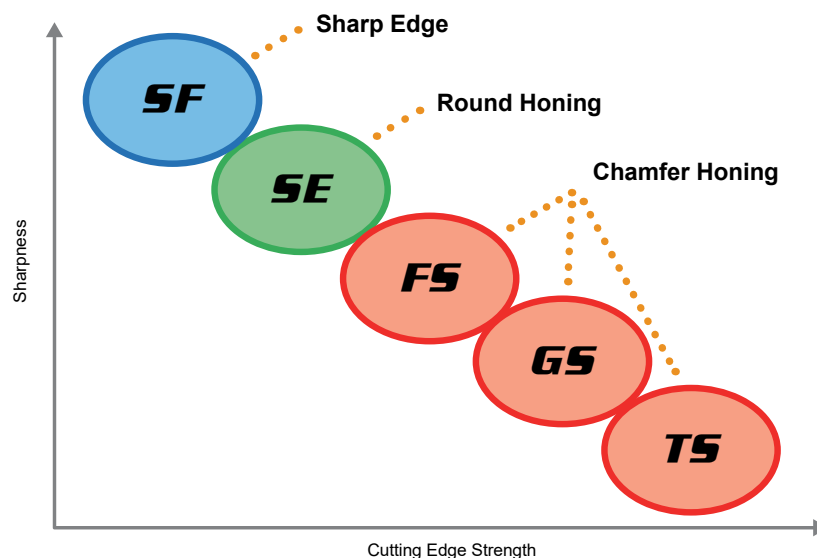

* See Index on page 4 for table icon reference. (●, ★, □)

Cutting Performance

Fracture Resistance Comparison During Interrupted Facing of High Strength Sintered Alloy

Increased fracture resistance even during heavy interrupted machining.

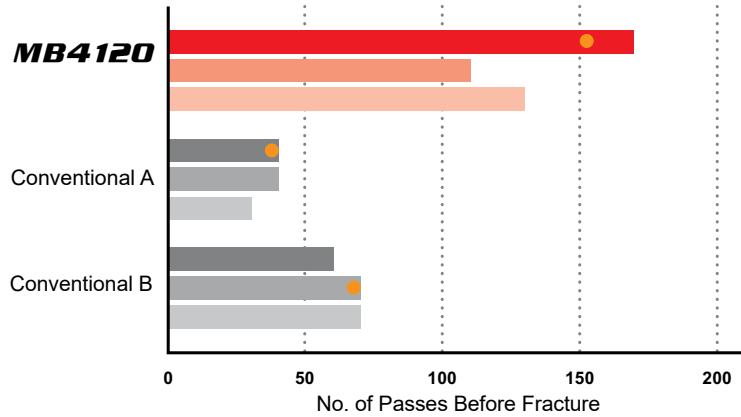

<Cutting Conditions>
 Work Material : High Strength Sintered Alloy
 Insert : NP-TNGA332-SE3
 Cutting Speed : $v_c=490$ SFM
 Feed per Rev. : $f=.006$ IPR
 Depth of Cut : $a_p=.004$ inch
 Cutting Mode : Wet Cutting

MB4120 150 pass



Conventional A 40 pass

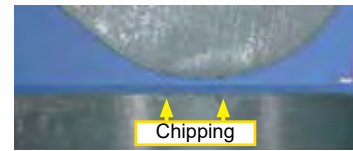

Conventional B 70 pass



Comparison in Continuous Machining of AISI No 35 B

Excellent fracture resistance compared to conventional products.

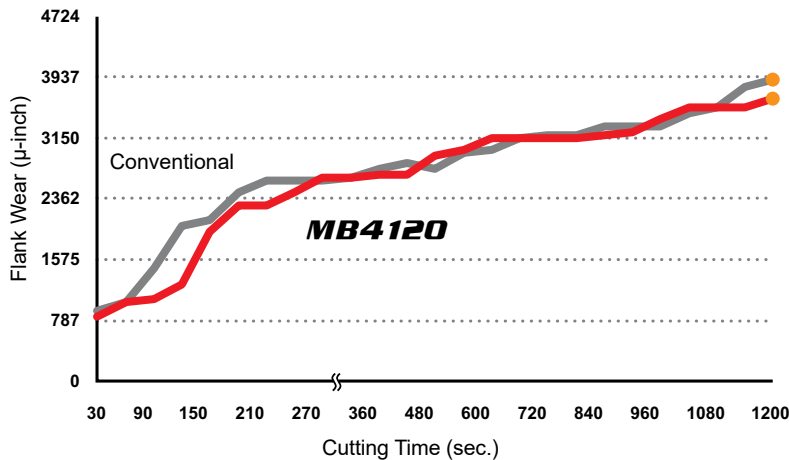

<Cutting Conditions>
 Work Material : AISI No 35 B (Perlite)
 Insert : NP-TNGA332-SF3
 Cutting Speed : $v_c=2625$ SFM
 Feed per Rev. : $f=.004$ IPR
 Depth of Cut : $a_p=.008$ inch
 Cutting Mode : Dry Cutting

MB4120 1200 sec



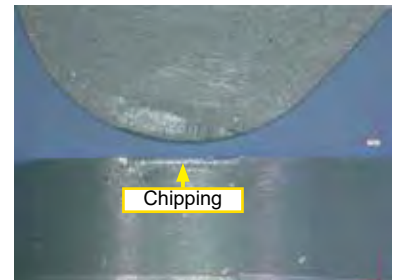

Conventional 1200 sec



Negative Inserts (With Hole) G Class

Turning Inserts
CBN/PCD

NEW PETIT CUT			
NP_002			
			
NEW PETIT CUT			
NP_002			
			

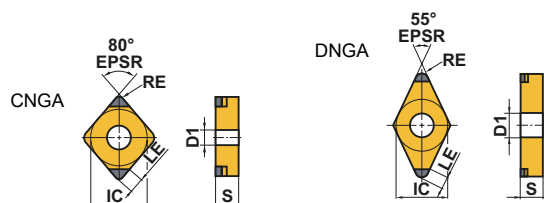

Order Number	MB4120	Cutting Edges	IC	S	RE	D1	LE
NP-CNGA431-SF2	●	2	.500	.187	.016	.203	.075
NP-CNGA432-SF2	●	2	.500	.187	.031	.203	.083
NP-CNGA433-SF2	●	2	.500	.187	.047	.203	.091
NP-CNGA431-SE2	●	2	.500	.187	.016	.203	.075
NP-CNGA432-SE2	●	2	.500	.187	.031	.203	.083
NP-CNGA433-SE2	●	2	.500	.187	.047	.203	.091
NP-CNGA431-FS2	●	2	.500	.187	.016	.203	.075
NP-CNGA432-FS2	●	2	.500	.187	.031	.203	.083
NP-CNGA433-FS2	●	2	.500	.187	.047	.203	.091
NP-CNGA431-GS2	●	2	.500	.187	.016	.203	.075
NP-CNGA432-GS2	●	2	.500	.187	.031	.203	.083
NP-CNGA433-GS2	●	2	.500	.187	.047	.203	.091
NP-CNGA431-TS2	●	2	.500	.187	.016	.203	.075
NP-CNGA432-TS2	●	2	.500	.187	.031	.203	.083
NP-CNGA433-TS2	●	2	.500	.187	.047	.203	.091
NP-DNGA431-SF2	●	2	.500	.187	.016	.203	.083
NP-DNGA432-SF2	●	2	.500	.187	.031	.203	.079
NP-DNGA433-SF2	●	2	.500	.187	.047	.203	.075
NP-DNGA441-SF2	●	2	.500	.250	.016	.203	.083
NP-DNGA442-SF2	●	2	.500	.250	.031	.203	.079
NP-DNGA443-SF2	●	2	.500	.250	.047	.203	.075
NP-DNGA431-SE2	●	2	.500	.187	.016	.203	.083
NP-DNGA432-SE2	●	2	.500	.187	.031	.203	.079
NP-DNGA433-SE2	●	2	.500	.187	.047	.203	.075
NP-DNGA441-SE2	●	2	.500	.250	.016	.203	.083
NP-DNGA442-SE2	●	2	.500	.250	.031	.203	.079
NP-DNGA443-SE2	●	2	.500	.250	.047	.203	.075
NP-DNGA431-FS2	●	2	.500	.187	.016	.203	.083
NP-DNGA432-FS2	●	2	.500	.187	.031	.203	.079
NP-DNGA433-FS2	●	2	.500	.187	.047	.203	.075
NP-DNGA441-FS2	●	2	.500	.250	.016	.203	.083
NP-DNGA442-FS2	●	2	.500	.250	.031	.203	.079
NP-DNGA443-FS2	●	2	.500	.250	.047	.203	.075
NP-DNGA431-GS2	●	2	.500	.187	.016	.203	.083
NP-DNGA432-GS2	●	2	.500	.187	.031	.203	.079
NP-DNGA433-GS2	●	2	.500	.187	.047	.203	.075
NP-DNGA441-GS2	●	2	.500	.250	.016	.203	.083
NP-DNGA442-GS2	●	2	.500	.250	.031	.203	.079
NP-DNGA443-GS2	●	2	.500	.250	.047	.203	.075
NP-DNGA431-TS2	●	2	.500	.187	.016	.203	.083
NP-DNGA432-TS2	●	2	.500	.187	.031	.203	.079
NP-DNGA433-TS2	●	2	.500	.187	.047	.203	.075
NP-DNGA441-TS2	●	2	.500	.250	.016	.203	.083
NP-DNGA442-TS2	●	2	.500	.250	.031	.203	.079
NP-DNGA443-TS2	●	2	.500	.250	.047	.203	.075

* See Index on page 4 for table icon reference. (●, ★, □)

Negative Inserts (With Hole) G Class

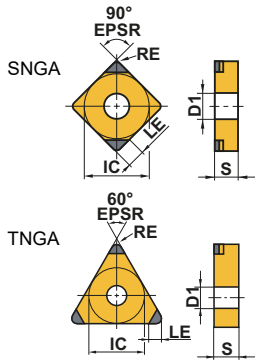



NEW PETIT CUT			
NP_002			
NEW PETIT CUT			
NP_003			

(inch)

Order Number	MB4120	Cutting Edges	IC	S	RE	D1	LE
NP-SNGA431-SF2	●	2	.500	.187	.016	.203	.083
NP-SNGA432-SF2	●	2	.500	.187	.031	.203	.091
NP-SNGA433-SF2	●	2	.500	.187	.047	.203	.098
NP-SNGA431-SE2	●	2	.500	.187	.016	.203	.083
NP-SNGA432-SE2	●	2	.500	.187	.031	.203	.091
NP-SNGA433-SE2	●	2	.500	.187	.047	.203	.098
NP-SNGA431-FS2	●	2	.500	.187	.016	.203	.083
NP-SNGA432-FS2	●	2	.500	.187	.031	.203	.091
NP-SNGA433-FS2	●	2	.500	.187	.047	.203	.098
NP-SNGA431-GS2	●	2	.500	.187	.016	.203	.083
NP-SNGA432-GS2	●	2	.500	.187	.031	.203	.091
NP-SNGA433-GS2	●	2	.500	.187	.047	.203	.098
NP-SNGA431-TS2	●	2	.500	.187	.016	.203	.083
NP-SNGA432-TS2	●	2	.500	.187	.031	.203	.091
NP-SNGA433-TS2	●	2	.500	.187	.047	.203	.098
NP-TNGA331-SF3	●	3	.375	.187	.016	.150	.063
NP-TNGA332-SF3	●	3	.375	.187	.031	.150	.071
NP-TNGA333-SF3	●	3	.375	.187	.047	.150	.075
NP-TNGA331-SE3	●	3	.375	.187	.016	.150	.063
NP-TNGA332-SE3	●	3	.375	.187	.031	.150	.071
NP-TNGA333-SE3	●	3	.375	.187	.047	.150	.075
NP-TNGA331-FS3	●	3	.375	.187	.016	.150	.063
NP-TNGA332-FS3	●	3	.375	.187	.031	.150	.071
NP-TNGA333-FS3	●	3	.375	.187	.047	.150	.075
NP-TNGA331-GS3	●	3	.375	.187	.016	.150	.063
NP-TNGA332-GS3	●	3	.375	.187	.031	.150	.071
NP-TNGA333-GS3	●	3	.375	.187	.047	.150	.075
NP-TNGA331-TS3	●	3	.375	.187	.016	.150	.063
NP-TNGA332-TS3	●	3	.375	.187	.031	.150	.071
NP-TNGA333-TS3	●	3	.375	.187	.047	.150	.075

Positive Inserts (With Hole) G Class

NEW PETIT CUT			
NP_002			
NEW PETIT CUT			
NP_003			

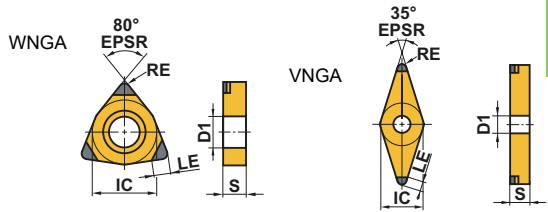

(inch)

Order Number	MB4120	Cutting Edges	IC	S	RE	D1	LE
NP-VNGA331-SF2	●	2	.375	.187	.016	.150	.098
NP-VNGA332-SF2	●	2	.375	.187	.031	.150	.079
NP-VNGA331-SE2	●	2	.375	.187	.016	.150	.098
NP-VNGA332-SE2	●	2	.375	.187	.031	.150	.079
NP-VNGA331-FS2	●	2	.375	.187	.016	.150	.098
NP-VNGA332-FS2	●	2	.375	.187	.031	.150	.079
NP-VNGA331-GS2	●	2	.375	.187	.016	.150	.098
NP-VNGA332-GS2	●	2	.375	.187	.031	.150	.079
NP-VNGA331-TS2	●	2	.375	.187	.016	.150	.098
NP-VNGA332-TS2	●	2	.375	.187	.031	.150	.079
NP-WNGA432-SF3	●	3	.500	.187	.031	.203	.083
NP-WNGA432-SE3	●	3	.500	.187	.031	.203	.083
NP-WNGA432-FS3	●	3	.500	.187	.031	.203	.083
NP-WNGA432-GS3	●	3	.500	.187	.031	.203	.083
NP-WNGA432-TS3	●	3	.500	.187	.031	.203	.083

NEW PETIT CUT			
NP_002			

Positive Inserts (With Hole) G Class

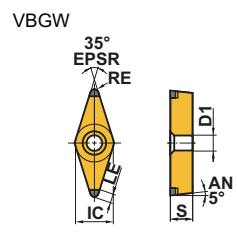

(inch)

Order Number	MB4120	Cutting Edges	IC	S	RE	D1	LE
NP-VBGW221-SF2	●	2	.250	.125	.016	.112	.098
NP-VBGW222-SF2	●	2	.250	.125	.031	.112	.079
NP-VBGW331-SF2	●	2	.375	.187	.016	.174	.098
NP-VBGW332-SF2	●	2	.375	.187	.031	.174	.079
NP-VBGW221-SE2	●	2	.250	.125	.016	.112	.098
NP-VBGW222-SE2	●	2	.250	.125	.031	.112	.079
NP-VBGW331-SE2	●	2	.375	.187	.016	.174	.098
NP-VBGW332-SE2	●	2	.375	.187	.031	.174	.079
NP-VBGW221-FS2	●	2	.250	.125	.016	.112	.098
NP-VBGW222-FS2	●	2	.250	.125	.031	.112	.079
NP-VBGW331-FS2	●	2	.375	.187	.016	.174	.098
NP-VBGW332-FS2	●	2	.375	.187	.031	.174	.079
NP-VBGW221-GS2	●	2	.250	.125	.016	.112	.098
NP-VBGW222-GS2	●	2	.250	.125	.031	.112	.079
NP-VBGW331-GS2	●	2	.375	.187	.016	.174	.098
NP-VBGW332-GS2	●	2	.375	.187	.031	.174	.079

* See Index on page 4 for table icon reference. (●, ★, □)

Positive Inserts (With Hole) G Class

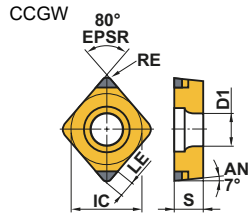

NEW PETIT CUT			
NP_002			

(inch)

Order Number	MB4120	Cutting Edges	IC	S	RE	D1	LE
NP-CCGW21.50.5-SF2	●	2	.250	.094	.008	.110	.071
NP-CCGW21.51-SF2	●	2	.250	.094	.016	.110	.075
NP-CCGW21.52-SF2	●	2	.250	.094	.031	.110	.083
NP-CCGW32.50.5-SF2	●	2	.375	.156	.008	.173	.071
NP-CCGW32.51-SF2	●	2	.375	.156	.016	.173	.075
NP-CCGW32.52-SF2	●	2	.375	.156	.031	.173	.083
NP-CCGW21.50.5-SE2	●	2	.250	.094	.008	.110	.071
NP-CCGW21.51-SE2	●	2	.250	.094	.016	.110	.075
NP-CCGW21.52-SE2	●	2	.250	.094	.031	.110	.083
NP-CCGW32.50.5-SE2	●	2	.375	.156	.008	.173	.071
NP-CCGW32.51-SE2	●	2	.375	.156	.016	.173	.075
NP-CCGW32.52-SE2	●	2	.375	.156	.031	.173	.083
NP-CCGW21.50.5-FS2	●	2	.250	.094	.008	.110	.071
NP-CCGW21.51-FS2	●	2	.250	.094	.016	.110	.075
NP-CCGW21.52-FS2	●	2	.250	.094	.031	.110	.083
NP-CCGW32.50.5-FS2	●	2	.375	.156	.008	.173	.071
NP-CCGW32.51-FS2	●	2	.375	.156	.016	.173	.075
NP-CCGW32.52-FS2	●	2	.375	.156	.031	.173	.083
NP-CCGW21.50.5-GS2	●	2	.250	.094	.008	.110	.071
NP-CCGW21.51-GS2	●	2	.250	.094	.016	.110	.075
NP-CCGW21.52-GS2	●	2	.250	.094	.031	.110	.083
NP-CCGW32.50.5-GS2	●	2	.375	.156	.008	.173	.071
NP-CCGW32.51-GS2	●	2	.375	.156	.016	.173	.075
NP-CCGW32.52-GS2	●	2	.375	.156	.031	.173	.083
NP-CCGW21.52-TS2	●	2	.250	.094	.031	.110	.083
NP-CCGW32.52-TS2	●	2	.375	.156	.031	.173	.083

Positive Inserts (With Hole) G Class

Turning Inserts
CBN/PCD

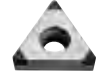
NEW PETIT CUT			
NP_002			
NEW PETIT CUT			
NP_003			

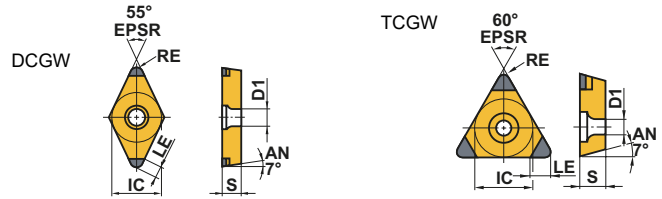

(inch)

Order Number	MB4120	Cutting Edges	IC	S	RE	D1	LE
NP-DCGW21.51-SF2	●	2	.250	.094	.016	.110	.083
NP-DCGW21.52-SF2	●	2	.250	.094	.031	.110	.079
NP-DCGW32.50.5-SF2	●	2	.375	.156	.008	.173	.059
NP-DCGW32.51-SF2	●	2	.375	.156	.016	.173	.083
NP-DCGW32.52-SF2	●	2	.375	.156	.031	.173	.079
NP-DCGW21.51-SE2	●	2	.250	.094	.016	.110	.083
NP-DCGW21.52-SE2	●	2	.250	.094	.031	.110	.079
NP-DCGW32.50.5-SE2	●	2	.375	.156	.008	.173	.059
NP-DCGW32.51-SE2	●	2	.375	.156	.016	.173	.083
NP-DCGW32.52-SE2	●	2	.375	.156	.031	.173	.079
NP-DCGW21.51-FS2	●	2	.250	.094	.016	.110	.083
NP-DCGW21.52-FS2	●	2	.250	.094	.031	.110	.079
NP-DCGW32.50.5-FS2	●	2	.375	.156	.008	.173	.059
NP-DCGW32.51-FS2	●	2	.375	.156	.016	.173	.083
NP-DCGW32.52-FS2	●	2	.375	.156	.031	.173	.079
NP-DCGW21.51-GS2	●	2	.250	.094	.016	.110	.083
NP-DCGW21.52-GS2	●	2	.250	.094	.031	.110	.079
NP-DCGW32.50.5-GS2	●	2	.375	.156	.008	.173	.059
NP-DCGW32.51-GS2	●	2	.375	.156	.016	.173	.083
NP-DCGW32.52-GS2	●	2	.375	.156	.031	.173	.079
NP-TCGW21.51-SF3	●	3	.250	.094	.016	.110	.063
NP-TCGW21.52-SF3	●	3	.250	.094	.031	.110	.071
NP-TCGW21.51-SE3	●	3	.250	.094	.016	.110	.063
NP-TCGW21.52-SE3	●	3	.250	.094	.031	.110	.071
NP-TCGW21.51-FS3	●	3	.250	.094	.016	.110	.063
NP-TCGW21.52-FS3	●	3	.250	.094	.031	.110	.071
NP-TCGW21.51-GS3	●	3	.250	.094	.016	.110	.063
NP-TCGW21.52-GS3	●	3	.250	.094	.031	.110	.071

* See Index on page 4 for table icon reference. (●, ★, □)

Positive Inserts (With Hole)

G Class

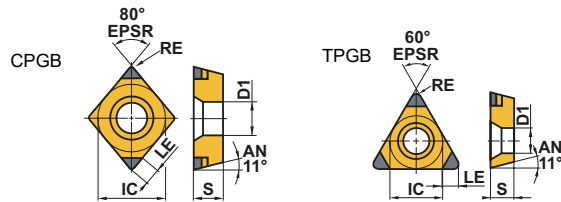

NEW PETIT CUT			
NP_002			
NEW PETIT CUT			
NP_003			

(inch)

Order Number	MB4120	Cutting Edges	IC	S	RE	D1	LE
NP-CPGB2.51.50.5-SE2	●	2	.313	.094	.008	.138	.071
NP-CPGB2.51.51-SE2	●	2	.313	.094	.016	.138	.075
NP-CPGB320.5-SE2	●	2	.375	.125	.008	.177	.071
NP-CPGB321-SE2	●	2	.375	.125	.016	.177	.075
NP-CPGB322-SE2	●	2	.375	.125	.031	.177	.083
NP-CPGB2.51.50.5-FS2	●	2	.313	.094	.008	.138	.071
NP-CPGB2.51.51-FS2	●	2	.313	.094	.016	.138	.075
NP-CPGB320.5-FS2	●	2	.375	.125	.008	.177	.071
NP-CPGB321-FS2	●	2	.375	.125	.016	.177	.075
NP-CPGB322-FS2	●	2	.375	.125	.031	.177	.083
NP-TPGB1.81.50.5-SF3	●	3	.219	.094	.008	.114	.059
NP-TPGB1.81.51-SF3	●	3	.219	.094	.016	.114	.063
NP-TPGB220.5-SF3	●	3	.250	.125	.008	.134	.059
NP-TPGB221-SF3	●	3	.250	.125	.016	.134	.063
NP-TPGB222-SF3	●	3	.250	.125	.031	.134	.071
NP-TPGB1.81.50.5-SE3	●	3	.219	.094	.008	.114	.059
NP-TPGB1.81.51-SE3	●	3	.219	.094	.016	.114	.063
NP-TPGB220.5-SE3	●	3	.250	.125	.008	.134	.059
NP-TPGB221-SE3	●	3	.250	.125	.016	.134	.063
NP-TPGB222-SE3	●	3	.250	.125	.031	.134	.071
NP-TPGB1.81.50.5-FS3	●	3	.219	.094	.008	.114	.059
NP-TPGB1.81.51-FS3	●	3	.219	.094	.016	.114	.063
NP-TPGB220.5-FS3	●	3	.250	.125	.008	.134	.059
NP-TPGB221-FS3	●	3	.250	.125	.016	.134	.063
NP-TPGB222-FS3	●	3	.250	.125	.031	.134	.071
NP-TPGB1.81.50.5-GS3	●	3	.219	.094	.008	.114	.059
NP-TPGB1.81.51-GS3	●	3	.219	.094	.016	.114	.063
NP-TPGB220.5-GS3	●	3	.250	.125	.008	.134	.059
NP-TPGB221-GS3	●	3	.250	.125	.016	.134	.063
NP-TPGB222-GS3	●	3	.250	.125	.031	.134	.071

Recommended Cutting Conditions

(inch)

Sintered Alloys

Work Material	Grade	Machining	vc (SFM)					f (IPR)	ap	Cutting Mode
			330	490	655	820	985			
General Sintered Alloys	MB4120	Turning						≤ .008	≤ .012	Dry, Wet
High Strength Sintered Alloys	MB4120	Turning						≤ .008	≤ .012	Dry, Wet
Hardened Sintered Alloys	MB4120	Turning						≤ .008	≤ .012	Dry, Wet

(inch)

Cast Irons

Work Material	Grade	Machining	vc (SFM)					f (IPR)	ap	Cutting Mode
			820	1640	2460	3280	4100			
Gray Cast Irons	MB4120	Turning						≤ .016	≤ .020	Dry, Wet

Application Examples

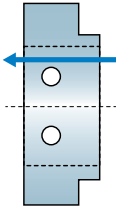
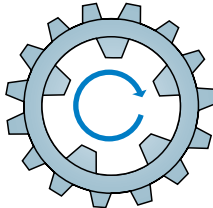
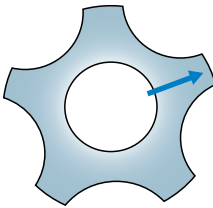
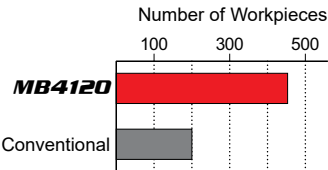
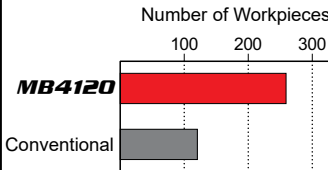
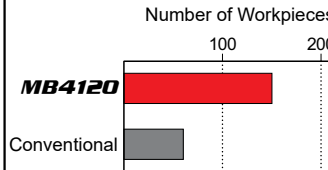
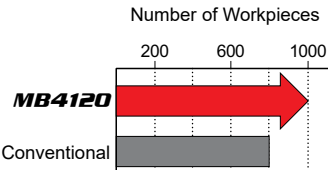
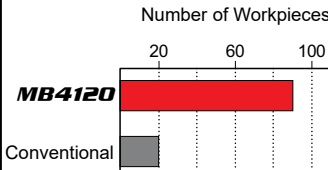
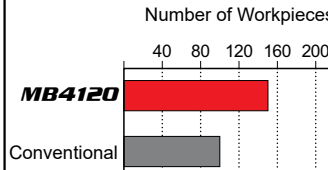
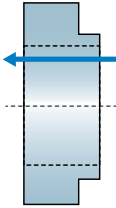
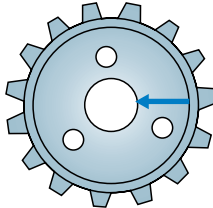
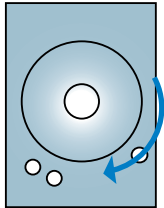
Insert	NP-DCGW32.52-SF2	NP-DCGW32.52-SF2	NP-DCGW32.52-SF2	
Workpiece	General Sintered Alloy 	General Sintered Alloy 	Iron-based Sintered Alloy (60HRB) Ra ≤ 1.0 μm 	
	Component	Housing(Interrupted Boring)	Case(Interrupted Boring)	Pinion(Interrupted Facing)
Cutting Conditions	Cutting Speed vc (SFM)	655	590	655
	Feed per Rev. f (IPR)	.003	.010	.0016 – .0020
	Depth of Cut ap (inch)	.008	.008 – .012	.016
Cutting Mode	Wet Cutting	Wet Cutting	Wet Cutting	
Results	 <p>Number of Workpieces</p> <p>100 300 500</p> <p>MB4120</p> <p>Conventional</p> <p>Double the tool life of the conventional product.</p>	 <p>Number of Workpieces</p> <p>100 200 300</p> <p>MB4120</p> <p>Conventional</p> <p>Double the tool life of the conventional product.</p>	 <p>Number of Workpieces</p> <p>100 200</p> <p>MB4120</p> <p>Conventional</p> <p>As compared with the conventional product, good surface finishes were maintained and 2.5 times longer tool life was achieved.</p>	
	Results	 <p>Number of Workpieces</p> <p>200 600 1000</p> <p>MB4120</p> <p>Conventional</p> <p>When comparing with the conventional product after machining the same number of workpieces, flank wear was smaller and further tool life extension can be expected.</p>	 <p>Number of Workpieces</p> <p>20 60 100</p> <p>MB4120</p> <p>Conventional</p> <p>As compared with the conventional cermet product, higher surface quality and more than 4 times longer tool life was achieved.</p>	 <p>Number of Workpieces</p> <p>40 80 120 160 200</p> <p>MB4120</p> <p>Conventional</p> <p>There is no abnormal damage and more than 1.5 times longer tool life was achieved.</p>
Component	Sprocket(Continuous Boring)	Sprocket(Interrupted Facing)	Mechanical Parts(Interrupted Facing)	
Cutting Conditions	Cutting Speed vc (SFM)	820	785	1970
	Feed per Rev. f (IPR)	.004	.005	.007 – .010
	Depth of Cut ap (inch)	.004	.002	.006 – .008
Cutting Mode	Wet Cutting	Wet Cutting	Dry Cutting	
Insert	NP-TNGA332-SF3	NP-TNGA332-SE3	NP-CNGA432-SF2	
Workpiece	High Strength Sintered Alloy 	General Sintered Alloy 	Cast Iron 	

The above application examples are customer's applications, so it can be different from the recommended conditions.

* See Index on page 4 for table icon reference. (●, ★, □)

CBN/PCD
Turning Inserts

Product Extension

DIA  EDGE



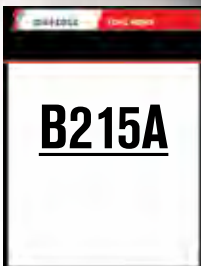

BC8100 SERIES

New Generation
Coated CBN Grades



Negative Inserts (With Hole) G Class CNGA, CNGM

Turning Inserts
CBN/PCD

NEW PETIT CUT NP_○4 	NEW PETIT CUT NP_○WS4  (With Wiper)	NEW PETIT CUT NP_○2 	NEW PETIT CUT NP_○W2  (With Wiper)
NEW PETIT CUT BF_ BM_  (With Breaker)			

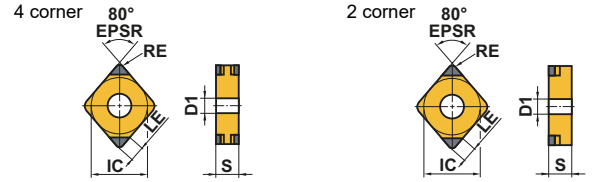

(inch)

Order Number	BC8105	BC8110	BC8120	BC8130	Cutting Edges	IC	S	RE	D1	LE
NP-CNGA431-GA4			★	★	4	.500	.187	.016	.203	.075
NP-CNGA432-GA4			★	★	4	.500	.187	.031	.203	.083
NP-CNGA433-GA4			★	★	4	.500	.187	.047	.203	.091
NP-CNGA431-GS4	●	★			4	.500	.187	.016	.203	.075
NP-CNGA432-GS4	●	★			4	.500	.187	.031	.203	.083
NP-CNGA433-GS4	●	★			4	.500	.187	.047	.203	.091
NEW NP-CNGA431-GH4		●	●	●	4	.500	.187	.016	.203	.075
NEW NP-CNGA432-GH4		●	●	●	4	.500	.187	.031	.203	.083
NEW NP-CNGA433-GH4		●	●	●	4	.500	.187	.047	.203	.091
NP-CNGA431-FS4	●	★	★		4	.500	.187	.016	.203	.075
NP-CNGA432-FS4	●	★	★		4	.500	.187	.031	.203	.083
NP-CNGA433-FS4	●	★	★		4	.500	.187	.047	.203	.091
NP-CNGA431-TA4			★	★	4	.500	.187	.016	.203	.075
NP-CNGA432-TA4			★	★	4	.500	.187	.031	.203	.083
NP-CNGA433-TA4			★	★	4	.500	.187	.047	.203	.091
NP-CNGA431-TS4		★			4	.500	.187	.016	.203	.075
NP-CNGA432-TS4		★			4	.500	.187	.031	.203	.083
NP-CNGA433-TS4		★			4	.500	.187	.047	.203	.091
NEW NP-CNGA431-TH4			●	★	4	.500	.187	.016	.203	.075
NEW NP-CNGA432-TH4			●	★	4	.500	.187	.031	.203	.083
NEW NP-CNGA433-TH4			●	★	4	.500	.187	.047	.203	.091
NEW NP-CNGA431-FSWS4	●	●	●		4	.500	.187	.016	.203	.075
NEW NP-CNGA432-FSWS4	●	●	●		4	.500	.187	.031	.203	.083
NEW NP-CNGA433-FSWS4	●	●	●		4	.500	.187	.047	.203	.091
NP-CNGA431-GAWS4			★	★	4	.500	.187	.016	.203	.075
NP-CNGA432-GAWS4			★	★	4	.500	.187	.031	.203	.083
NP-CNGA433-GAWS4			★	★	4	.500	.187	.047	.203	.091
NP-CNGA431-GSWS4	●	★			4	.500	.187	.016	.203	.075
NP-CNGA432-GSWS4	●	★			4	.500	.187	.031	.203	.083
NP-CNGA433-GSWS4	●	★			4	.500	.187	.047	.203	.091
NP-CNGA430.5-GA2			●		2	.500	.187	.008	.203	.071
NP-CNGA431-GA2			●	●	2	.500	.187	.016	.203	.075
NP-CNGA432-GA2			●	●	2	.500	.187	.031	.203	.083
NP-CNGA433-GA2			●	●	2	.500	.187	.047	.203	.091
NP-CNGA430.5-GS2		●			2	.500	.187	.008	.203	.071
NP-CNGA431-GS2	●	●			2	.500	.187	.016	.203	.075
NP-CNGA432-GS2	●	●			2	.500	.187	.031	.203	.083
NP-CNGA433-GS2	●	●			2	.500	.187	.047	.203	.091
NEW NP-CNGA431-GH2		●	●	●	2	.500	.187	.016	.203	.075
NEW NP-CNGA432-GH2		●	●	●	2	.500	.187	.031	.203	.083
NEW NP-CNGA433-GH2		●	●	●	2	.500	.187	.047	.203	.091
NP-CNGA430.5-FS2		●			2	.500	.187	.008	.203	.071

* See Index on page 4 for table icon reference. (●, ★, □)

Negative Inserts (With Hole)

G Class
CNGA, CNGM

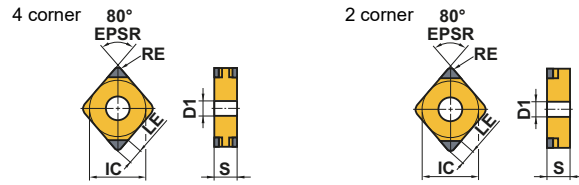





NEW PETIT CUT	NEW PETIT CUT	NEW PETIT CUT	NEW PETIT CUT
NP_004	NP_00WS4	NP_002	NP_00W02
	 (With Wiper)		 (With Wiper)
NEW PETIT CUT			
BF_ BM_			
 (With Breaker)			

Order Number					Cutting Edges	(inch)				
	BC8105	BC8110	BC8120	BC8130		IC	S	RE	D1	LE
NP-CNGA431-FS2	●	●	●		2	.500	.187	.016	.203	.075
NP-CNGA432-FS2	●	●	●		2	.500	.187	.031	.203	.083
NP-CNGA433-FS2	●	●	●		2	.500	.187	.047	.203	.091
NP-CNGA431-TA2			●	●	2	.500	.187	.016	.203	.075
NP-CNGA432-TA2			●	●	2	.500	.187	.031	.203	.083
NP-CNGA433-TA2			●	●	2	.500	.187	.047	.203	.091
NP-CNGA431-TS2		★			2	.500	.187	.016	.203	.075
NP-CNGA432-TS2		★			2	.500	.187	.031	.203	.083
NP-CNGA433-TS2		★			2	.500	.187	.047	.203	.091
NEW NP-CNGA431-TH2			●	●	2	.500	.187	.016	.203	.075
NEW NP-CNGA432-TH2			●	●	2	.500	.187	.031	.203	.083
NEW NP-CNGA433-TH2			●	●	2	.500	.187	.047	.203	.091
NEW NP-CNGA431-FBWL2	●	●	●		2	.500	.187	.016	.203	.075
NEW NP-CNGA432-FBWL2	●	●	●		2	.500	.187	.031	.203	.083
NEW NP-CNGA433-FBWL2	●	●	●		2	.500	.187	.047	.203	.091
NEW NP-CNGA431-FSWS2	●	●	●		2	.500	.187	.016	.203	.075
NEW NP-CNGA432-FSWS2	●	●	●		2	.500	.187	.031	.203	.083
NEW NP-CNGA433-FSWS2	●	●	●		2	.500	.187	.047	.203	.091
NP-CNGA431-GAWS2			●	●	2	.500	.187	.016	.203	.075
NP-CNGA432-GAWS2			●	●	2	.500	.187	.031	.203	.083
NP-CNGA433-GAWS2			●	●	2	.500	.187	.047	.203	.091
NEW NP-CNGA431-GBWL2	●	●	●		2	.500	.187	.016	.203	.075
NEW NP-CNGA432-GBWL2	●	●	●		2	.500	.187	.031	.203	.083
NEW NP-CNGA433-GBWL2	●	●	●		2	.500	.187	.047	.203	.091
NP-CNGA431-GSWS2	●	●			2	.500	.187	.016	.203	.075
NP-CNGA432-GSWS2	●	●			2	.500	.187	.031	.203	.083
NP-CNGA433-GSWS2	●	●			2	.500	.187	.047	.203	.091
BF-CNGM431-TS2		★			2	.500	.187	.016	.203	.075
BF-CNGM432-TS2		★			2	.500	.187	.031	.203	.083
BF-CNGM433-TS2		★			2	.500	.187	.047	.203	.091
BM-CNGM431-TA2			●		2	.500	.187	.016	.203	.075
BM-CNGM432-TA2			●		2	.500	.187	.031	.203	.083
BM-CNGM433-TA2			●		2	.500	.187	.047	.203	.091

Positive Inserts (With Hole) G Class CCGW 7°, CCGT 7°, CPGB 11°

Turning Inserts
CBN/PCD

NEW PETIT CUT	NEW PETIT CUT	NEW PETIT CUT	NEW PETIT CUT
NP_○2	NP_○W2	BF_ BM_	NP
	 (With Wiper)	 (With Breaker)	 *
NEW PETIT CUT			
NP_○2			
			

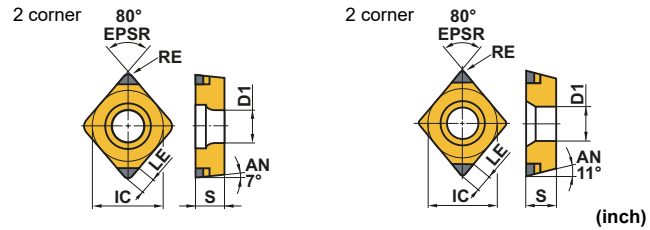

Order Number	BC8105	BC8110	BC8120	BC8130	Cutting Edges	IC	S	RE	D1	LE
NP-CCGW21.50.5-GA2			●		2	.250	.094	.008	.110	.071
NP-CCGW21.51-GA2			●	●	2	.250	.094	.016	.110	.075
NP-CCGW21.52-GA2			●	●	2	.250	.094	.031	.110	.083
NP-CCGW32.50.5-GA2			●		2	.375	.156	.008	.173	.071
NP-CCGW32.51-GA2			●	●	2	.375	.156	.016	.173	.075
NP-CCGW32.52-GA2			●	●	2	.375	.156	.031	.173	.083
NP-CCGW21.50.5-GS2	●	●			2	.250	.094	.008	.110	.071
NP-CCGW21.51-GS2	●	●			2	.250	.094	.016	.110	.075
NP-CCGW21.52-GS2	●	●			2	.250	.094	.031	.110	.083
NP-CCGW32.50.5-GS2	●	●			2	.375	.156	.008	.173	.071
NP-CCGW32.51-GS2	●	●			2	.375	.156	.016	.173	.075
NP-CCGW32.52-GS2	●	●			2	.375	.156	.031	.173	.083
NEW NP-CCGW32.51-GH2		●	●	●	2	.375	.156	.016	.173	.075
NEW NP-CCGW32.52-GH2		●	●	●	2	.375	.156	.031	.173	.083
NP-CCGW21.50.5-FS2		●			2	.250	.094	.008	.110	.071
NP-CCGW21.51-FS2		●			2	.250	.094	.016	.110	.075
NP-CCGW21.52-FS2		●			2	.250	.094	.031	.110	.083
NP-CCGW32.50.5-FS2	●	●			2	.375	.156	.008	.173	.071
NP-CCGW32.51-FS2	●	●	●		2	.375	.156	.016	.173	.075
NP-CCGW32.52-FS2	●	●	●		2	.375	.156	.031	.173	.083
NP-CCGW21.51-TA2				●	2	.250	.094	.016	.110	.075
NP-CCGW21.52-TA2				●	2	.250	.094	.031	.110	.083
NP-CCGW32.51-TA2			●	●	2	.375	.156	.016	.173	.075
NP-CCGW32.52-TA2			●	●	2	.375	.156	.031	.173	.083
NEW NP-CCGW32.51-TH2			●	●	2	.375	.156	.016	.173	.075
NEW NP-CCGW32.52-TH2			●	●	2	.375	.156	.031	.173	.083
NEW NP-CCGW32.51-FBWL2	●	●	●		2	.375	.156	.016	.173	.075
NEW NP-CCGW32.52-FBWL2	●	●	●		2	.375	.156	.031	.173	.083
NEW NP-CCGW32.51-FSWS2	●	●	●		2	.375	.156	.016	.173	.075
NEW NP-CCGW32.52-FSWS2	●	●	●		2	.375	.156	.031	.173	.083
NP-CCGW32.51-GAWS2			●	●	2	.375	.156	.016	.173	.075
NP-CCGW32.52-GAWS2			●	●	2	.375	.156	.031	.173	.083
NEW NP-CCGW32.51-GBWL2	●	●	●		2	.375	.156	.016	.173	.075
NEW NP-CCGW32.52-GBWL2	●	●	●		2	.375	.156	.031	.173	.083
NP-CCGW32.51-GSWS2	●	●			2	.375	.156	.016	.173	.075
NP-CCGW32.52-GSWS2	●	●			2	.375	.156	.031	.173	.083
BF-CCGT32.51-TS2		★			2	.375	.156	.016	.173	.071
BF-CCGT32.52-TS2		★			2	.375	.156	.031	.173	.079
BM-CCGT32.51-TA2			●		2	.375	.156	.016	.173	.075
BM-CCGT32.52-TA2			●		2	.375	.156	.031	.173	.083
NP-CCGW03S102GS	●				1	.156*	.055	.008	.079	.043
NP-CCGW03S104GS	●				1	.156*	.055	.016	.079	.043

* Diameter of inscribed circle is non-ISO standard. (For SCLC type)

* See Index on page 4 for table icon reference. (●, ★, □)

GRUPO VING



NEW PRODUCT

DIA  **EDGE**

GW SERIES



LONG LASTING & EASY TO USE
cutting off & grooving system

Grooving



Easy to Utilize Configuration that Improves Tool Handling

Clamp

Simple insert clamping method offering high rigidity.

To prevent the insert from being pulled out during machining a reverse taper angle has been designed from the front of the insert. Additionally the design also includes 3 large locating faces between the insert and the blade offering increased cutting edge reliability. The blade itself is made from a special alloy steel to suit this application.

In respect to insert indexing, a unique wrench is supplied to ensure ease when changing the insert.

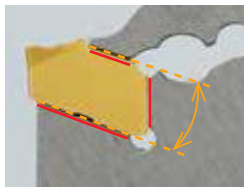

Reverse Taper Angle

Voice of Developer

Just how easy is it to set an insert?

With the use of a unique wrench, it is possible to locate and remove the insert with one simple action making it easier for use in the workplace.

Grooving

GW Series

Simplicity & convenience. Introducing a new kind of cutting off & grooving system that maximizes usability without sacrificing machining performance.



Through Coolant Blade

Increased wear resistance due to the use of 2 through coolant ejection holes.

2 through coolant holes supply the coolant to both the rake and flank face, leading to effective cutting edge cooling and increased wear resistance.



Additionally this blade can also be used for both low pressure and high pressure coolant (1000 PSI).

Voice of Developer

How is it possible to reduce heat generation?

The 2 coolant holes used in the blade are capable of using high coolant pressures of up to (1000 PSI). This is achieved by using as large as possible through coolant hole diameter. The ejection holes are located close to the cutting edge to improve the cutting edge cooling effect and increasing wear resistance.

Coolant Ports

Flexible set up possible with the use of 6 coolant ports.

There are 6 coolant ports designed into the tool block. This makes it easier for the end user to set up the tool block and blade to a configuration that suits their needs. If necessary it is also possible to use coolant hose. The ejection type coolant also improves cutting edge cooling and chip evacuation.

Voice of Developer

Possible set up to suit the requirements of the workplace environment.

One of the objectives of this product is to respond to the customers complaints that "the product did not fit and could not be used". Starting with the coolant outlet that prevents leaks even when oil quantity or overhangs change. Everything from the material and the shape of the O-ring, to the length of the hose has been tailored to the effective use in the workplace.

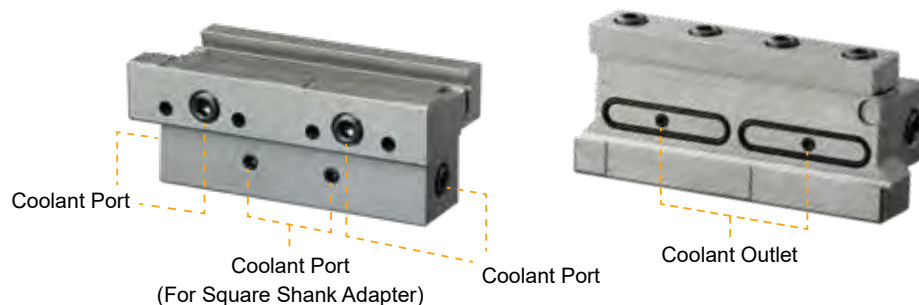

Simple Insert Clamping Method Offering High Rigidity Clamp Mechanism

Highly Reliable Insert Clamping

Grooving

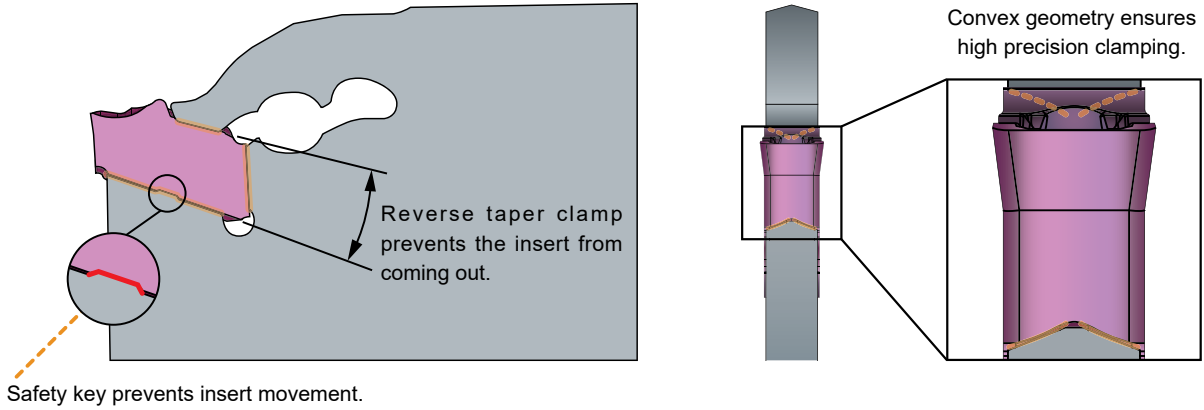

Easy Insert Indexing

The inserts can be indexed easily with a one action movement of the wrench.

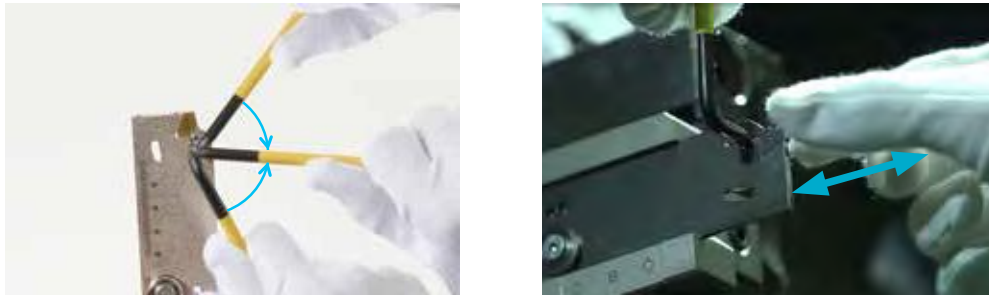

Excellent Clamp Durability

High clamp durability when compared to a conventional tool.

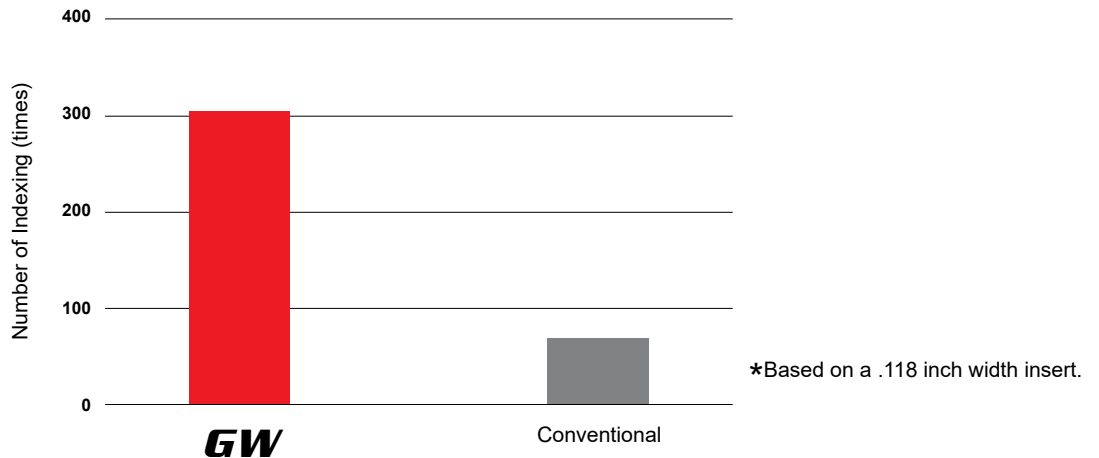

Suitable for Various Set Ups Improving Tool Handling

Internal Coolant

A scale is marked on the blade to make it easier to set the correct overhang length, as long as the arrow of the blade is set up with an overhang length that is within the band on the tool block then through coolant is possible. The blade is possible to use with both external or through coolant.



2 Through Coolant Holes

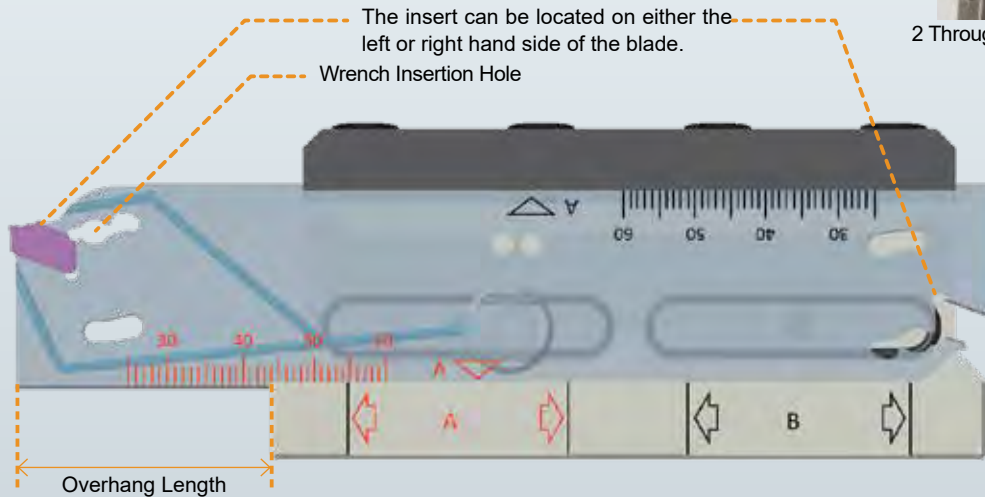

Grooving

Effects of Through Coolant

Cutting Off

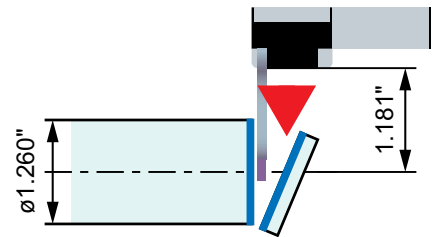
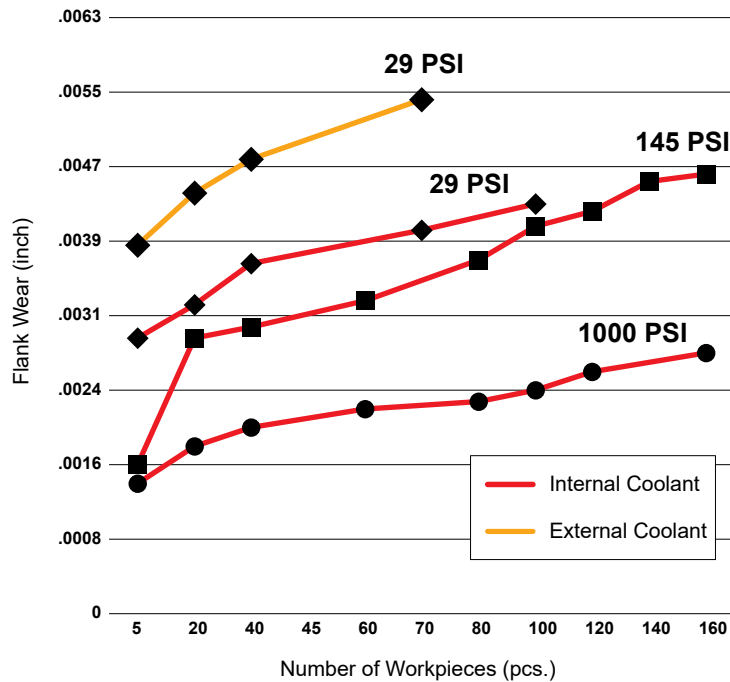

<Cutting Conditions>

- Work Material : AISI 304 (ø1.260 inch)
- Insert : GW1M0300F030N-GW (VP20RT)
- Grooving Width CW = .118 inch
- Cutting Speed : vc = 590 SFM
- Feed per Rev. : f = .006 IPR
- ø.394 inch < .001 IPR
- Overhang Length : 1.181 inch

* See Index on page 4 for table icon reference. (●, ★, □)

Breaker System Offering Excellent Chip Disposal Properties

Chip Breaker

Low Feeds



GS Breaker

Medium Feeds



Neutral Right Hand / Left Hand
GM Breaker

Insert Grades

Grooving

Work Material / Machining Condition	P Steels	M Stainless Steels	K Cast Irons	S Heat Resistant Alloys / Titanium Alloys
Stable	MY5015		MY5015	VP10RT
Machining Condition	VP10RT	VP10RT	VP10RT	
	VP20RT	VP20RT	VP20RT	VP20RT
	VP30RT	VP30RT		
Unstable				

VP20RT (1st Recommendation)

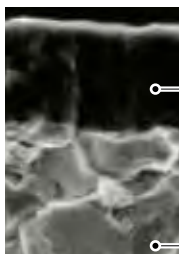

● PVD coated grade suitable for a wide range of applications. The combination of a special tough cemented carbide substrate with MIRACLE coating provides an excellent balance of wear and fracture resistance.

MIRACLE Coating
Carbide Substrate (HRA90.5)

MY5015

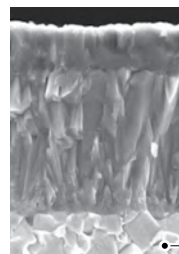

● MY5015 is a CVD coated grade with excellent wear resistance even at high temperatures. It provides longer tool life when machining cast and ductile cast irons. Also suitable for high speed continuous cutting of steels.

CVD Coated Carbide
Carbide Substrate

VP10RT

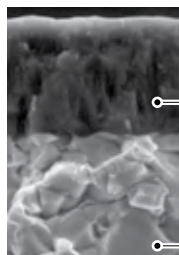

● PVD coated grade with a cemented carbide substrate harder than VP20RT. For use on difficult-to-cut materials and for extending tool life.

MIRACLE Coating
Carbide Substrate (HRA92.0)

VP30RT

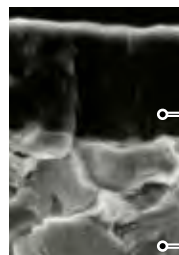

● A combination of a tough, special cemented carbide substrate and MIRACLE coating. Ideal for heavy interrupted cutting of stainless and general steels.

MIRACLE Coating (Al,Ti)N
Carbide Substrate

Identification of GW Series

Insert / Blade / Tool Block

● Insert

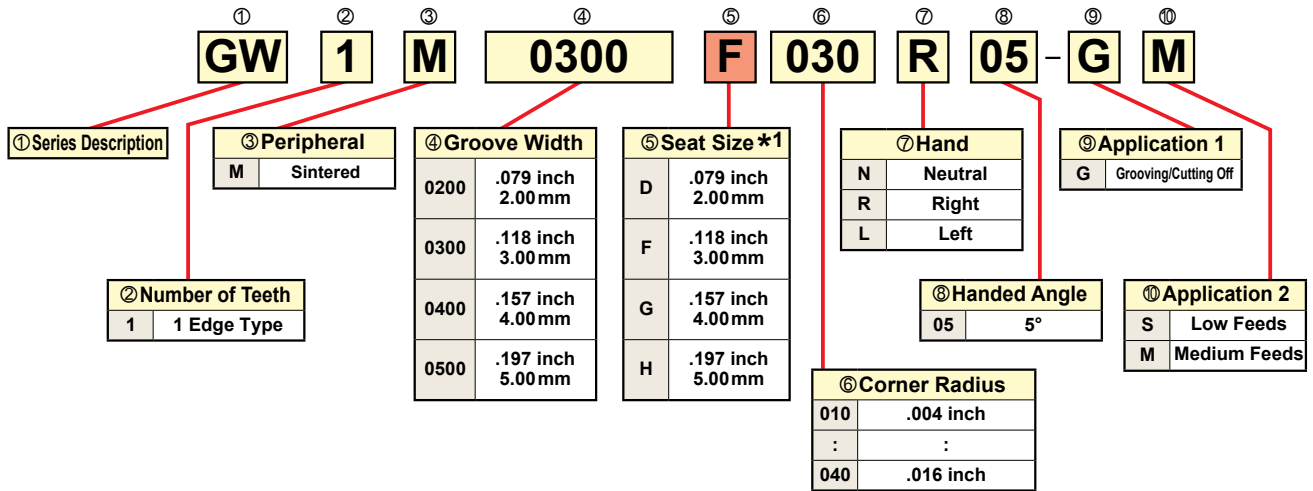

Grooving

● Blade

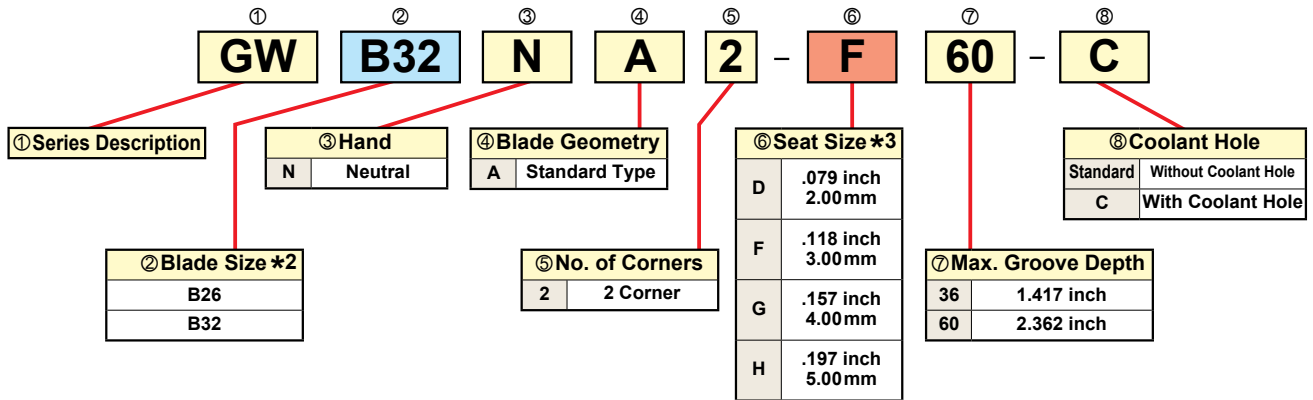

● Tool Block

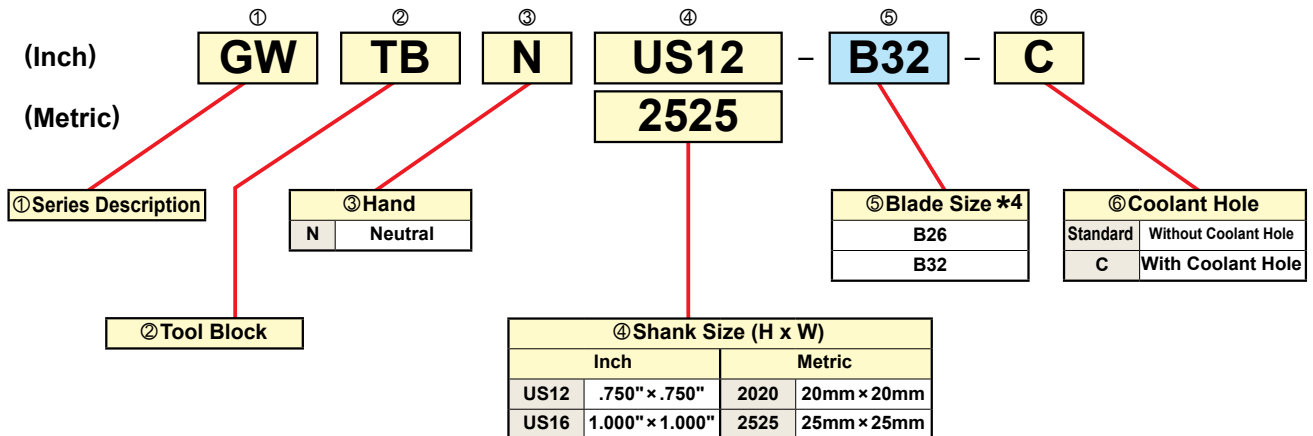

*1 Select seat size with the same symbol as that of blade.
 *2 Select blade size with the same symbol as that of tool block.
 *3 Select seat size with the same symbol of the insert.
 *4 Select blade size with the same symbol as that of blade.

* See Index on page 4 for table icon reference. (●, ★, □)

GW Blade

- Simple insert clamping method offering high rigidity.
- The blade is possible to use with both external or through coolant.
- Groove Depth CW .079 – .197 inch

For External Cutting Off / Grooving

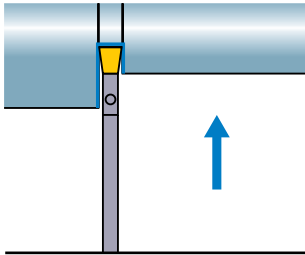

Fig.1

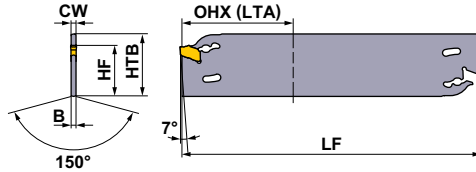
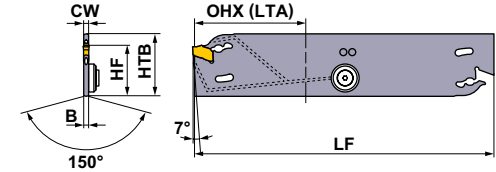

Fig.2



Without Coolant Hole

(inch)

Seat Size	CW	*1 CUTDIA	Order Number	Stock	*2 OHN	*3 OHX (LTA)	B	LF	HTB	HF	Fig.	Insert Type		Wrench	Tool Block Type
												Insert Type	Wrench		
D	.079	2.835	GWB26NA2-D36	●	.630	1.417	.061	4.331	1.024	.843	1	GW1M0200D	GWY39L	GWTBN-B26	
		4.724	GWB32NA2-D60	●	.630	2.362	.061	5.906	1.260	.984	1	GW1M0200D	GWY39L	GWTBN-B32	
F	.118	2.835	GWB26NA2-F36	●	.630	1.417	.096	4.331	1.024	.843	1	GW1M0300F	GWY39L	GWTBN-B26	
		4.724	GWB32NA2-F60	●	.630	2.362	.096	5.906	1.260	.984	1	GW1M0300F	GWY39L	GWTBN-B32	
G	.157	2.835	GWB26NA2-G36	●	.748	1.417	.132	4.331	1.024	.843	1	GW1M0400G	GWY39L	GWTBN-B26	
		4.724	GWB32NA2-G60	●	.748	2.362	.132	5.906	1.260	.984	1	GW1M0400G	GWY39L	GWTBN-B32	
H	.197	2.835	GWB26NA2-H36	●	.748	1.417	.167	4.331	1.024	.843	1	GW1M0500H	GWY39L	GWTBN-B26	
		4.724	GWB32NA2-H60	●	.748	2.362	.167	5.906	1.260	.984	1	GW1M0500H	GWY39L	GWTBN-B32	

With Coolant Hole

(inch)

Seat Size	CW	*1 CUTDIA	Order Number	Stock	*2 OHN	*3 OHX (LTA)	B	LF	HTB	HF	Fig.	Insert Type		Wrench	Tool Block Type
												Insert Type	Wrench		
D	.079	2.835	GWB26NA2-D36-C	●	.630	1.417	.061	4.331	1.024	.843	2	GW1M0200D	GWY39L	GWTBN-B26-C	
		4.724	GWB32NA2-D60-C	●	.630	2.362	.061	5.906	1.260	.984	2	GW1M0200D	GWY39L	GWTBN-B32-C	
F	.118	2.835	GWB26NA2-F36-C	●	.630	1.417	.096	4.331	1.024	.843	2	GW1M0300F	GWY39L	GWTBN-B26-C	
		4.724	GWB32NA2-F60-C	●	.630	2.362	.096	5.906	1.260	.984	2	GW1M0300F	GWY39L	GWTBN-B32-C	
G	.157	2.835	GWB26NA2-G36-C	●	.748	1.417	.132	4.331	1.024	.843	2	GW1M0400G	GWY39L	GWTBN-B26-C	
		4.724	GWB32NA2-G60-C	●	.748	2.362	.132	5.906	1.260	.984	2	GW1M0400G	GWY39L	GWTBN-B32-C	
H	.197	2.835	GWB26NA2-H36-C	●	.748	1.417	.167	4.331	1.024	.843	2	GW1M0500H	GWY39L	GWTBN-B26-C	
		4.724	GWB32NA2-H60-C	●	.748	2.362	.167	5.906	1.260	.984	2	GW1M0500H	GWY39L	GWTBN-B32-C	

*1 CUTDIA: Maximum Cut Off Diameter *2 OHN: Minimum Overhang Length *3 OHX(LTA): Maximum Overhang Length
 * Recommended Maximum Coolant Pressure 1000PSI

Spare Parts for Blades with Coolant Hole

(inch)

Order Number	CW	Spare Parts		Plug Wrench
		Washer	Clamp Screw	
GWB26NA2-D36-C	.079	①GWW04038	GW04005F	HKY20R
GWB32NA2-D60-C	.079	①GWW04038	GW04005F	HKY20R
GWB26NA2-F36-C	.118	①GWW04038	GW04005F	HKY20R
GWB32NA2-F60-C	.118	①GWW04038	GW04005F	HKY20R
GWB26NA2-G36-C	.157	②GWW04026	GW04005F	HKY20R
GWB32NA2-G60-C	.157	②GWW04026	GW04005F	HKY20R
GWB26NA2-H36-C	.197	②GWW04026	GW04005F	HKY20R
GWB32NA2-H60-C	.197	②GWW04026	GW04005F	HKY20R

Tool Block (Inch)

Tool Block (Inch)

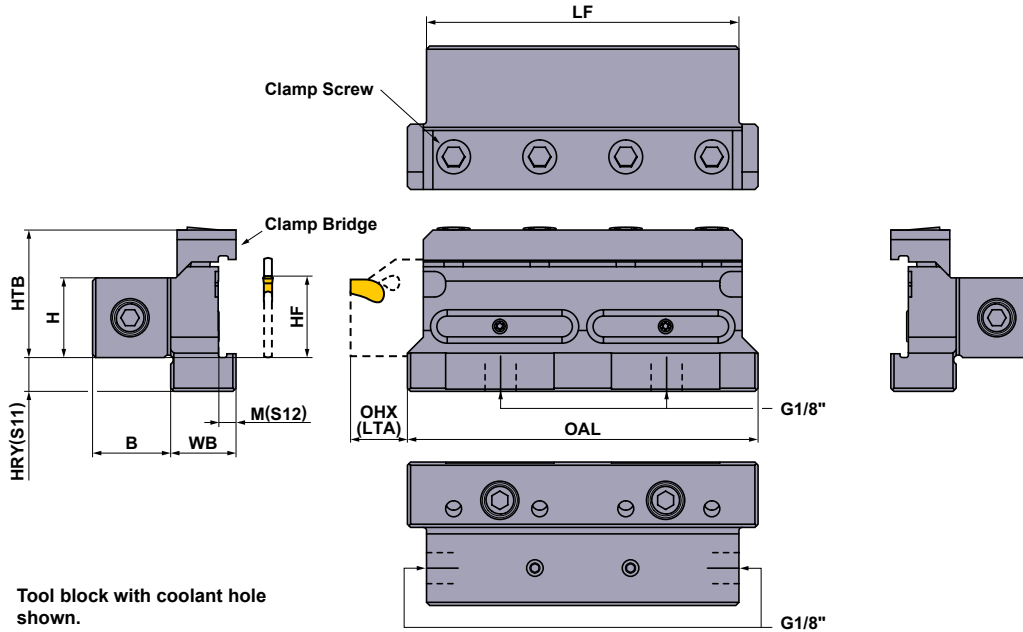

Grooving

Without Coolant Hole

Order Number	Stock	H	HF	HTB	HRY (S11)	B	WB	M (S12)	LF	OAL	(inch)		
											①	②	③
											Clamp Bridge	Clamp Screw	Wrench
GWTBNUS12-B26	●	.750	.750	1.28	.470	.730	.790	.200	2.950	3.350	① GWCW1	HSC06020	HKY50R
GWTBNUS12-B32	●	.750	.750	1.34	.650	.730	.810	.220	3.940	4.330	② GWCW2	HSC06020	HKY50R
GWTBNUS16-B26	●	1.000	1.000	1.53	.220	.980	.790	.200	2.950	3.350	① GWCW1	HSC06020	HKY50R
GWTBNUS16-B32	●	1.000	1.000	1.59	.400	.980	.810	.220	3.940	4.330	② GWCW2	HSC06020	HKY50R

With Coolant Hole

Order Number	Stock	H	HF	HTB	HRY (S11)	B	WB	M (S12)	LF	OAL	(inch)		
											①	②	③
											Clamp Bridge	Clamp Screw	Wrench
GWTBNUS12-B26-C	●	.750	.750	1.28	.470	.730	.790	.200	2.950	3.350	① GWCW1	HSC06020	HKY50R
GWTBNUS12-B32-C	●	.750	.750	1.34	.650	.730	.810	.220	3.940	4.330	② GWCW2	HSC06020	HKY50R
GWTBNUS16-B26-C	●	1.000	1.000	1.53	.220	.980	.790	.200	2.950	3.350	① GWCW1	HSC06020	HKY50R
GWTBNUS16-B32-C	●	1.000	1.000	1.59	.400	.980	.810	.220	3.940	4.330	② GWCW2	HSC06020	HKY50R

* Recommended Maximum Coolant Pressure 1000 PSI

* Clamp Torque (lbf-in) : HSC06020=62

Spare Parts for Tool Block with Coolant Hole

Order Number	①	②	③	④	⑤	⑥
	O-ring	Plug	Plug	Wrench	Plug	Wrench
GWTBNUS12-B26-C	①ORGW332N9	HGJ-PT1/8	HSD05004S	HKY25R	CS300590T	TKY08R
GWTBNUS12-B32-C	②ORGW457N9	HGJ-PT1/8	HSD05004S	HKY25R	CS300590T	TKY08R
GWTBNUS16-B26-C	①ORGW332N9	HGJ-PT1/8	HSD05004S	HKY25R	CS300590T	TKY08R
GWTBNUS16-B32-C	②ORGW457N9	HGJ-PT1/8	HSD05004S	HKY25R	CS300590T	TKY08R

Tool Block (Metric)

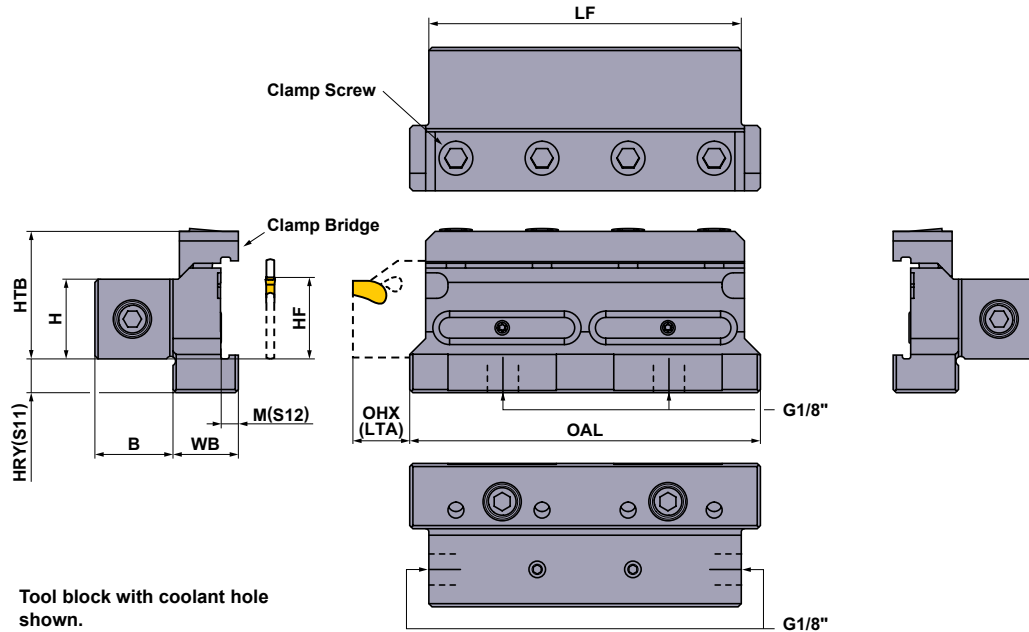

Without Coolant Hole

(mm)

Order Number	Stock	H	HF	HTB	HRY (S11)	B	WB	M (S12)	LF	OAL			
											Clamp Bridge	Clamp Screw	Wrench
GWTBN2020-B26	★	20	20	33.5	11	19.5	20.0	5.0	75	85	① GWCW1	HSC06020	HKY50R
GWTBN2020-B32	★	20	20	35.0	15.6	19.5	20.5	5.5	100	110	② GWCW2	HSC06020	HKY50R
GWTBN2525-B26	★	25	25	38.5	6	24.5	20.0	5.0	75	85	① GWCW1	HSC06020	HKY50R
GWTBN2525-B32	★	25	25	40.0	10.6	24.5	20.5	5.5	100	110	② GWCW2	HSC06020	HKY50R

With Coolant Hole

(mm)

Order Number	Stock	H	HF	HTB	HRY (S11)	B	WB	M (S12)	LF	OAL			
											Clamp Bridge	Clamp Screw	Wrench
GWTBN2020-B26-C	★	20	20	33.5	11	19.5	20.0	5.0	75	85	① GWCW1	HSC06020	HKY50R
GWTBN2020-B32-C	★	20	20	35.0	15.6	19.5	20.5	5.5	100	110	② GWCW2	HSC06020	HKY50R
GWTBN2525-B26-C	★	25	25	38.5	6	24.5	20.0	5.0	75	85	① GWCW1	HSC06020	HKY50R
GWTBN2525-B32-C	★	25	25	40.0	10.6	24.5	20.5	5.5	100	110	② GWCW2	HSC06020	HKY50R

* Recommended Maximum Coolant Pressure 7MPa

* Clamp Torque (N • m) : HSC06020=7.0

Spare Parts for Tool Block with Coolant Hole

Order Number						
	O-ring	Plug	Plug	Wrench	Plug	Wrench
GWTBN2020-B26-C	① ORGW332N9	HGJ-PT1/8	HSD05004S	HKY25R	CS300590T	TKY08R
GWTBN2020-B32-C	② ORGW457N9	HGJ-PT1/8	HSD05004S	HKY25R	CS300590T	TKY08R
GWTBN2525-B26-C	① ORGW332N9	HGJ-PT1/8	HSD05004S	HKY25R	CS300590T	TKY08R
GWTBN2525-B32-C	② ORGW457N9	HGJ-PT1/8	HSD05004S	HKY25R	CS300590T	TKY08R

Inserts

(inch)

Application	Order Number	Stock				CW			REL	RER	PSIRR	Geometry
		Coating				Width of Cutting Edge		Tolerance				
		MY5015	VP10RT	VP20RT	VP30RT	inch	mm					
Grooving, Cutting Off	GW1M0200D020N-GS		●	●	●	.079	2.00	± .0012	.008	.008	—	
	GW1M0300F020N-GS		●	●	●	.118	3.00	± .0012	.008	.008	—	
	GW1M0400G020N-GS		●	●	●	.157	4.00	± .0016	.008	.008	—	
	GW1M0500H030N-GS		●	●	●	.197	5.00	± .0016	.012	.012	—	
	GW1M0200D020N-GM	●	●	●	●	.079	2.00	± .0012	.008	.008	—	
	GW1M0300F030N-GM	●	●	●	●	.118	3.00	± .0012	.012	.012	—	
	GW1M0400G030N-GM	●	●	●	●	.157	4.00	± .0016	.012	.012	—	
	GW1M0500H040N-GM	●	●	●	●	.197	5.00	± .0016	.016	.016	—	
Cutting Off	GW1M0200D020R05-GM		●	●	●	.079	2.00	± .0012	.008	.008	.197	
	GW1M0200D020L05-GM		●	●	●	.079	2.00	± .0012	.008	.008	.197	
	GW1M0300F030R05-GM		●	●	●	.118	3.00	± .0012	.012	.012	.197	
	GW1M0300F030L05-GM		●	●	●	.118	3.00	± .0012	.012	.012	.197	
	GW1M0400G030R05-GM		●	●	●	.157	4.00	± .0016	.012	.012	.197	
	GW1M0400G030L05-GM		●	●	●	.157	4.00	± .0016	.012	.012	.197	
	GW1M0500H040R05-GM		●	●	●	.197	5.00	± .0016	.016	.016	.197	
	GW1M0500H040L05-GM		●	●	●	.197	5.00	± .0016	.016	.016	.197	





Right hand insert shown.

Grooving

* See Index on page 4 for table icon reference. (●, ★, □)

Coolant Hose Kit

(inch)

Connector Type	Order Number	Stock	Hose Length	Kit Details								
												
				Code No.	Code No.	QTY.	Code No.	QTY.	Code No.	QTY.	Code No.	QTY.
Straight	CS-1/8-150SS	●	5.91	HOSE-1/8-150	—	—	—	—	AD-G1/8	2	WA-M10	2
Straight	CS-1/8-200SS	●	7.87	HOSE-1/8-200	—	—	—	—	AD-G1/8	2	WA-M10	2
Straight	CS-1/8-250SS	●	9.84	HOSE-1/8-250	—	—	—	—	AD-G1/8	2	WA-M10	2
Straight	CS-1/8-300SS	●	11.81	HOSE-1/8-300	—	—	—	—	AD-G1/8	2	WA-M10	2
Elbow Straight	CS-1/8-150BS	●	5.91	HOSE-1/8-150	AD-BM10	1	BB-G1/8	1	AD-G1/8	1	WA-M10	3
Elbow Straight	CS-1/8-200BS	●	7.87	HOSE-1/8-200	AD-BM10	1	BB-G1/8	1	AD-G1/8	1	WA-M10	3
Elbow Straight	CS-1/8-250BS	●	9.84	HOSE-1/8-250	AD-BM10	1	BB-G1/8	1	AD-G1/8	1	WA-M10	3
Elbow Straight	CS-1/8-300BS	●	11.81	HOSE-1/8-300	AD-BM10	1	BB-G1/8	1	AD-G1/8	1	WA-M10	3
Elbow	CS-1/8-150BB	●	5.91	HOSE-1/8-150	AD-BM10	2	BB-G1/8	2	—	—	WA-M10	4
Elbow	CS-1/8-200BB	●	7.87	HOSE-1/8-200	AD-BM10	2	BB-G1/8	2	—	—	WA-M10	4
Elbow	CS-1/8-250BB	●	9.84	HOSE-1/8-250	AD-BM10	2	BB-G1/8	2	—	—	WA-M10	4
Elbow	CS-1/8-300BB	●	11.81	HOSE-1/8-300	AD-BM10	2	BB-G1/8	2	—	—	WA-M10	4

Connection Screw Size = G1/8"

Grooving

Mounting Example

Elbow Straight Type

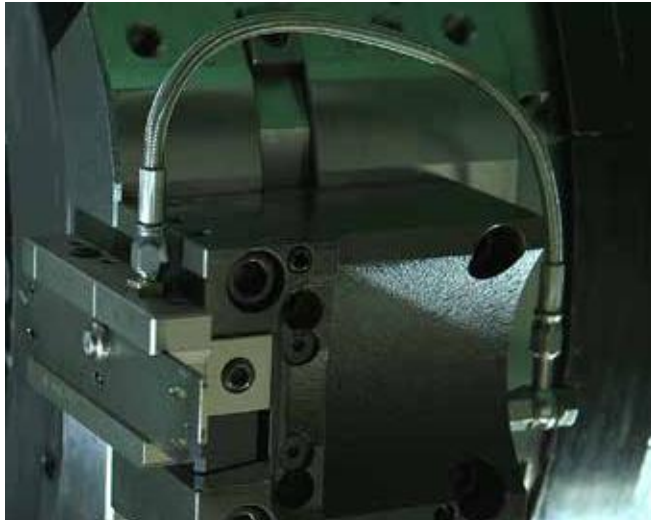

Elbow Type



Recommended Cutting Conditions

Cutting Speed

Work Material	Properties	Grade	Cutting Speed vc (SFM)						
			165	330	490	655	820	985	
P Mild Steels	≤160HB	VP20RT		330		785			
		VP10RT		360		820			
	Carbon Steels Alloy Steels	160–280HB	VP20RT		260		655		
			VP10RT		295		690		
			VP30RT		195		590		
			MY5015		360		820		
		≥280HB	VP20RT		195		525		
			VP10RT		230		560		
	M Stainless Steels	≤270HB	VP20RT		195		590		
			VP10RT		230		620		
VP30RT				130		525			
K Gray Cast Irons	Tensile Strength ≤300MPa	VP20RT		260		655			
		VP10RT		295		690			
		MY5015		460		985			
	Ductile Cast Irons	Tensile Strength ≤800MPa	VP20RT		195		525		
			VP10RT		230		560		
			MY5015		295		690		
S Heat Resistant Alloys Titanium Alloys	-	VP20RT	100 195						
		VP10RT	130 230						

Grooving

(Note 1) VP20RT is the first recommended grade for materials.
 (Note 2) For VP10RT, VP20RT, VP30RT and MY5015, wet cutting is recommended.

Feed per Revolution

GM Breaker

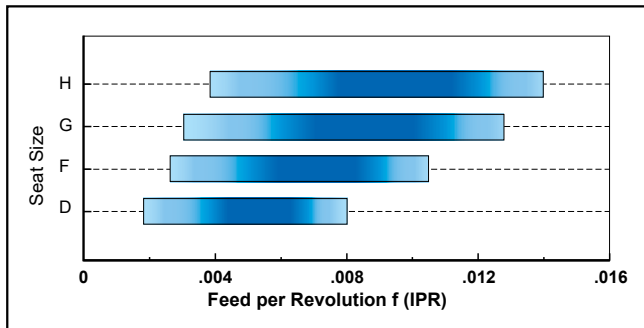

GS Breaker

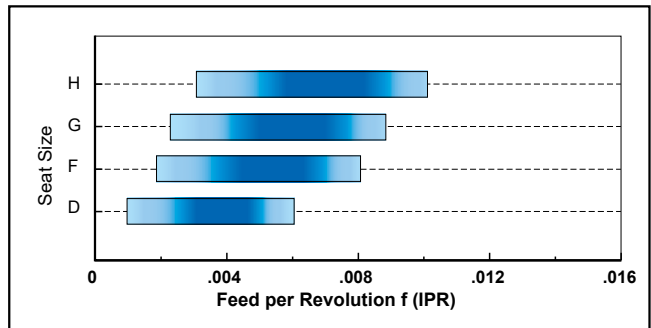

Chip Breaker	Feed per Revolution f (IPR)			
	Seat Size D	Seat Size F	Seat Size G	Seat Size H
GM Breaker	.002–.008	.003–.010	.003–.013	.004–.014
GS Breaker	.001–.006	.002–.008	.002–.009	.003–.010

* See Index on page 4 for table icon reference. (●, ★, □)

Cutting Performance

Cutting Off of Alloy Steel (AISI 4140)

No abnormal cutting edge damage, possible to extend tool life.

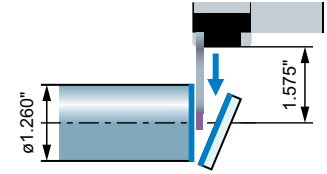
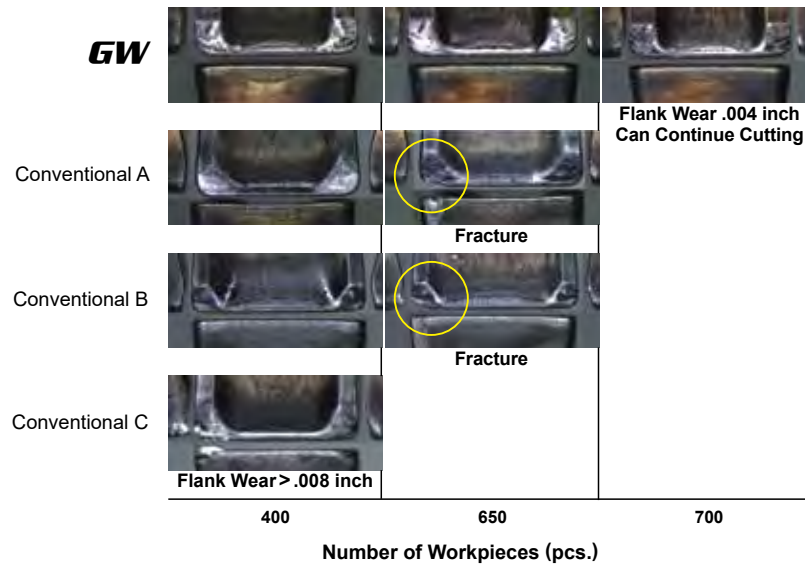

<Cutting Conditions>

Work Material : AISI 4140
 Insert : GW1M0300F030N-GM (MY5015)
 Grooving Width CW .118 inch
 Cutting Speed : vc=560 SFM
 Feed per Rev. : f=.006 IPR
 ø.394 inch < .001 IPR
 Overhang Length : 1.575 inch
 Cutting Mode : Internal Coolant 145 PSI

***Tool Life Criteria : Flank wear up to .008 inch or fracture.**

Grooving

Interrupted Cutting Off of Alloy Steel (AISI 4140)

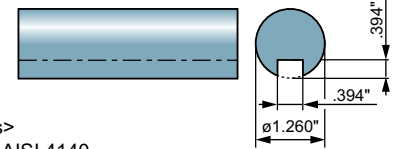
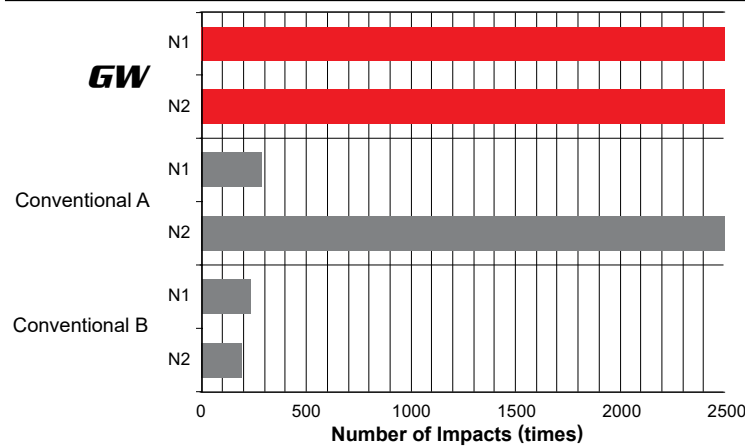

<Cutting Conditions>

Work Material : AISI 4140
 Insert : GW1M0300F030N-GM (VP30RT)
 Grooving Width CW .118 inch
 Cutting Speed : vc=395 SFM
 Feed per Rev. : f=.008 IPR
 ø.394 inch < .001 IPR
 Overhang Length : 1.181 inch
 Cutting Mode : Internal Coolant 145 PSI

***Tool Life Criteria : Fracture or breakage.**

Cutting Off of Stainless Steel (AISI 304)

No abnormal cutting edge damage, 4 times longer tool life was achieved.

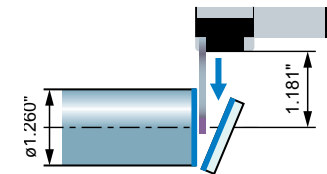
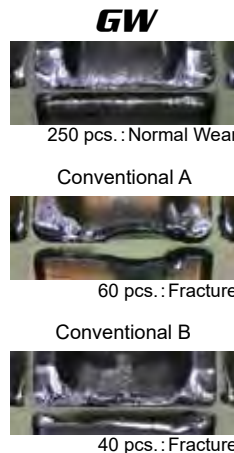
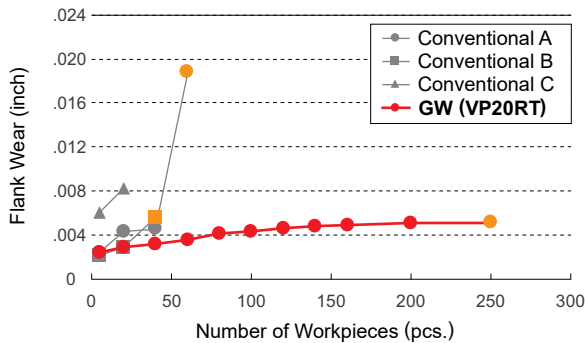

<Cutting Conditions>

Work Material : AISI 304
 Insert : GW1M0300F030N-GM (VP20RT)
 Grooving Width CW .118 inch
 Cutting Speed : vc=590 SFM
 Feed per Rev. : f=.006 IPR
 ø.394 inch < .001 IPR
 Overhang Length : 1.181 inch
 Cutting Mode : Internal Coolant 145 PSI

***Tool Life Criteria : Flank wear up to .008 inch or fracture.**

Application Examples

Insert	GW1M0300F030N-GM(VP20RT)	GW1M0300F030N-GM(VP20RT)
Workpiece	<p>Stainless Steel</p>	<p>Carbon Tool Steel (AISI W5)</p>
Component	Machine Parts	Machine Parts
Cutting Method	Cutting Off	Cutting Off
Cutting Conditions	Cutting Speed <i>vc</i> (SFM)	525
	Feed per Rev. <i>f</i> (IPR)	.004
Cutting Mode	Internal Coolant (290 PSI)	Internal Coolant (72.5 PSI)
Results	<p>As compared to the conventional item, double the tool life was achieved. Additionally due to the use of the unique wrench tool handling was improved.</p> <p>Number of Workpieces</p>	<p>A good surface finish was obtained due to smooth chip evacuation when compared to the conventional item.</p>
Insert	GW1M0300F030N-GM(VP30RT)	GW1M0300F030N-GM(VP20RT)
Workpiece	<p>Carbon Steel (AISI 1045)</p>	<p>Stainless Steel (JIS SUS420J2)</p>
Component	Machine Tool Parts	Machine Parts
Cutting Method	Cutting Off	Cutting Off
Cutting Conditions	Cutting Speed <i>vc</i> (SFM)	330
	Feed per Rev. <i>f</i> (IPR)	.004
Cutting Mode	External Coolant	Internal Coolant
Results	<p>While the conventional item, broke during machining, the GW was able to machine more than double the number of workpieces.</p> <p>Number of Workpieces</p>	<p>As compared to the conventional item double the number of workpieces was achieved.</p> <p>Number of Workpieces</p>

The above application examples are customer's applications, so it can be different from the recommended conditions.

Solid

END MILL S



NEW PRODUCT

VQTBUR SERIES



BARREL ENDMILL FOR
Finish cutting of
Titanium alloys

DIA  **EDGE**



B232A

Barrel End Mill for Finish Cutting of Titanium Alloys

Nose radius designed for both fillet milling and tangential form radius blade surface machining.

Radial Accuracy

RE1 and RE2 ± 0.0004 inch

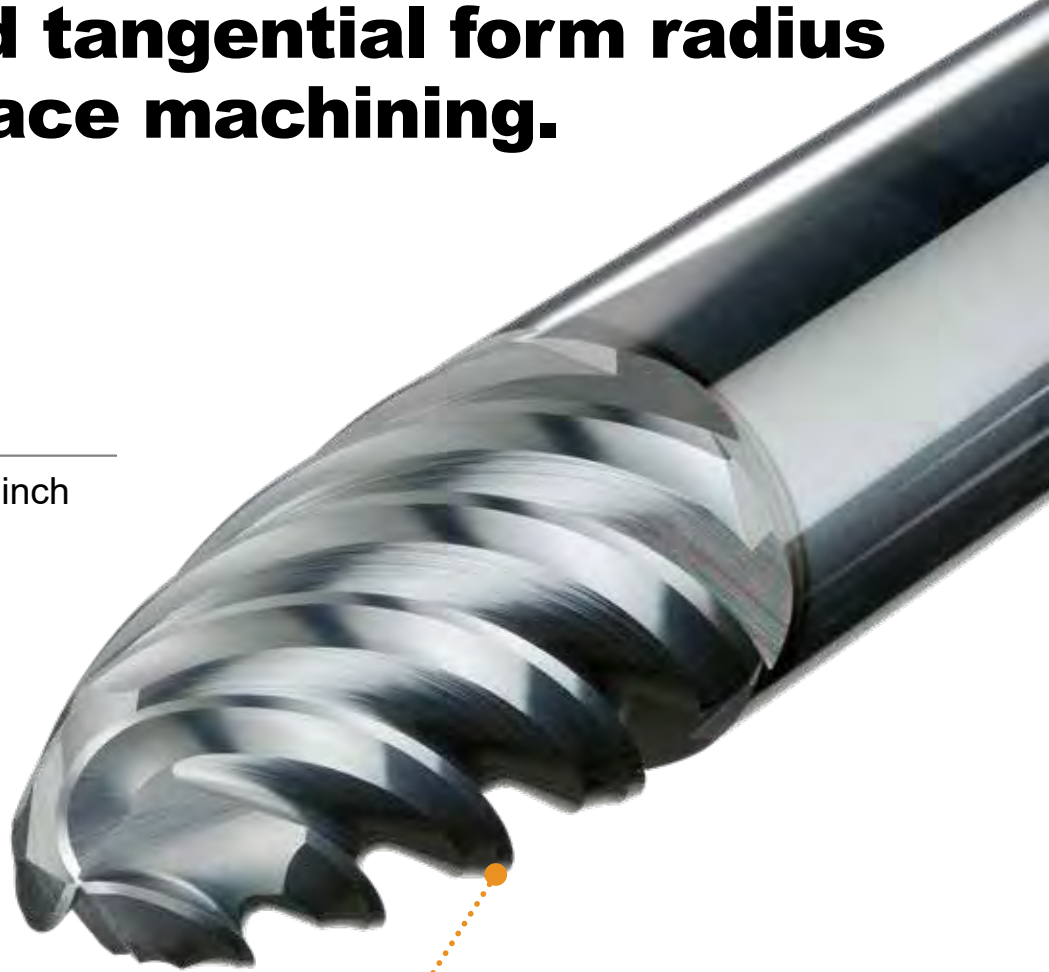

Solid End
Mills

Optimum Cutting Edge Design

6-flute Peripheral Cutting Edge

Multi cutting edge designed for high efficiency machining.
Irregular pitch design prevents chattering.

3-flute End Cutting Edge

A wide flute for superior chip evacuation.

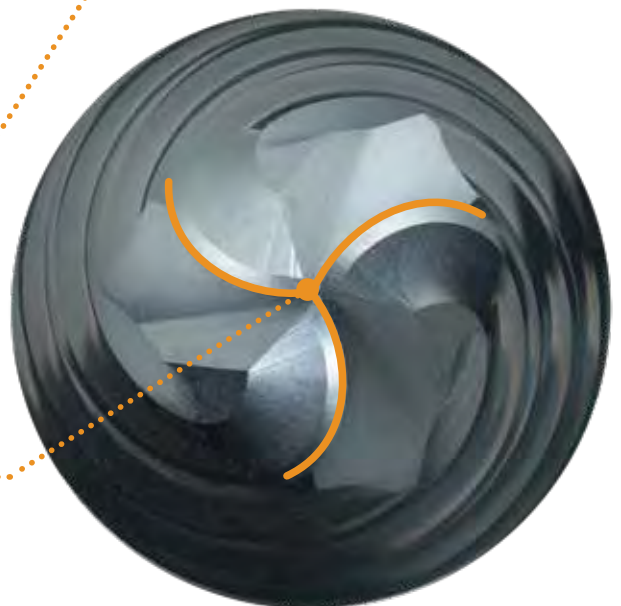

Ideal Shape

Compared with a ball nose end mill, the tangential form radius is larger and cusp height is minimized and more controllable. This design makes highly efficient machining with a pick feed.

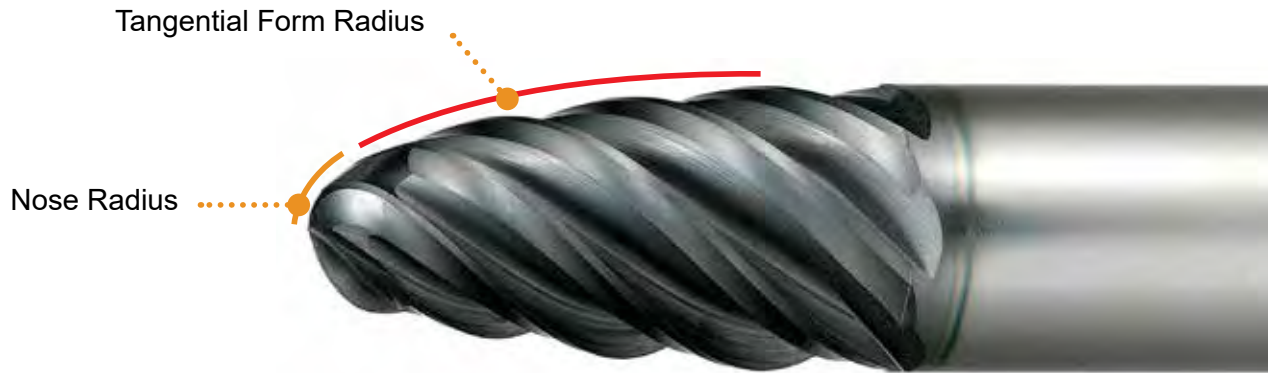

Nose and tangential form part has two distinct radii.

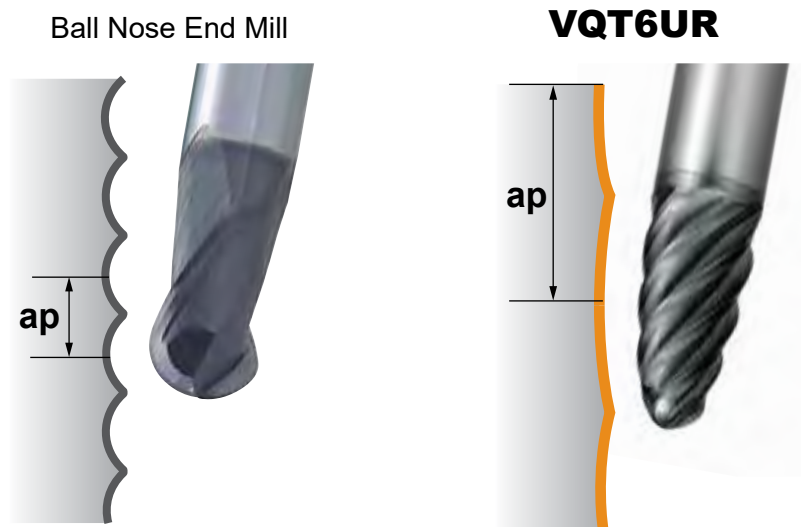

Shorter cutting distance contributes to longer tool life.

Comparison of Machining Time by CAM Simulation

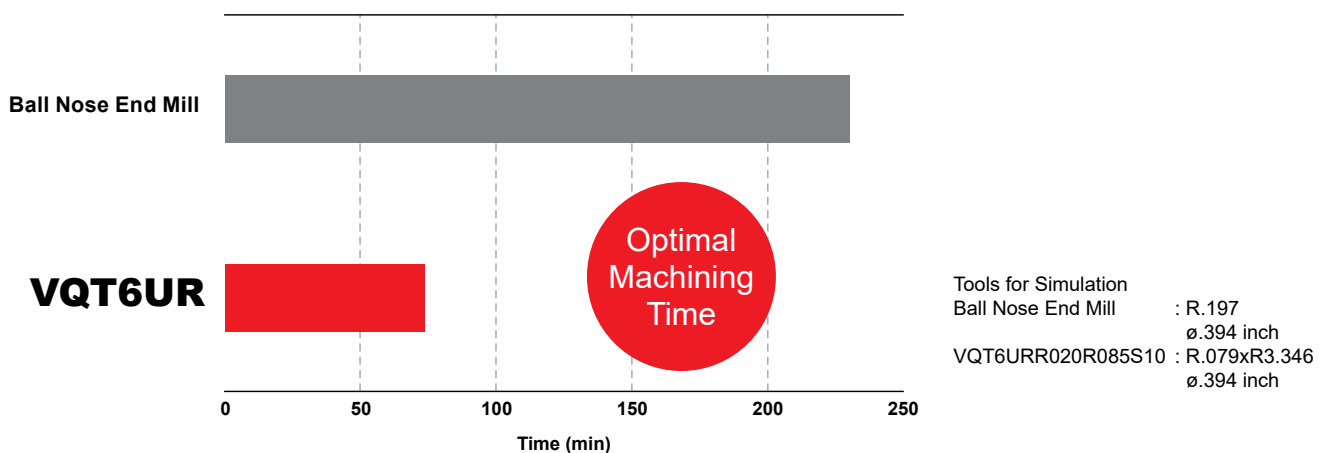

* See Index on page 4 for table icon reference. (●, ★, □)



Barrel, Medium cut length, 6 flute

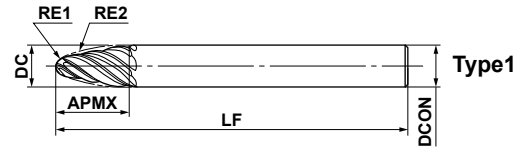

R	RE1 ≤ 4	RE2 ≤ 100			
	±0.01	±0.01			
h6	DCON ≤ 10	DCON = 12			
	$\begin{matrix} 0 \\ -0.009 \end{matrix}$	$\begin{matrix} 0 \\ -0.011 \end{matrix}$			

- Nose and tangential form part has two distinct radii.
- Irregular pitch design prevents chattering.

(mm)

Order Number	DC	RE1	RE2	APMX	LF	DCON	No.F [*]	Stock	Type
VQT6URR020R075S08	8	2	75	21	90	8	6	●	1
VQT6URR020R085S10	10	2	85	26	100	10	6	●	1
VQT6URR030R075S10	10	3	75	22	100	10	6	●	1
VQT6URR040R100S12	12	4	100	25	110	12	6	●	1

Note 1) SMART MIRACLE coating has very low electrical conductivity; therefore, an external contact type of tool setter (electric transmitted) may not work.
When measuring the tool length, an internal contact/non-electric type or laser tool setter is recommended.

* Number of Flutes

DC = Cutting Dia. APMX = Depth of Cut Max.
RE1 = Nose Radius LF = Functional Length
RE2 = Tangential Form Radius DCON = Connection Diameter

Recommended Cutting Conditions

Effective Angle

Please refer to the table below for the use of the nose radius (RE1) and tangential form radius (RE2).

Order Number	Nose Radius		Tangential Form Radius	
	RE1	Effective Angle	RE2	Effective Angle
VQT6URR020R075S08	.079 (2mm)	76.6°	2.953 (75mm)	13.4°
VQT6URR020R085S10	.079 (2mm)	74.5°	3.346 (85mm)	15.5°
VQT6URR030R075S10	.118 (3mm)	76.4°	2.953 (75mm)	13.6°
VQT6URR040R100S12	.157 (4mm)	78.3°	3.937 (100mm)	11.7°

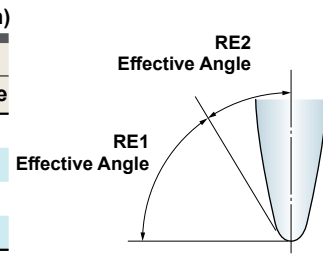

Side Milling with the Use of the Tangential Form Radius (RE2)

Workpiece Material				Mild Steels ($\leq 180\text{HB}$) Carbon Steels, Alloy Steels (180–280HB)				Austenitic Stainless Steels ($\leq 200\text{HB}$) Titanium Alloys				Aluminum Alloys (Si < 5%)			
DC		RE2		Revolution	Feed Rate	Depth of Cut	Depth of Cut	Revolution	Feed Rate	Depth of Cut	Depth of Cut	Revolution	Feed Rate	Depth of Cut	Depth of Cut
mm	inch	mm	inch	(min^{-1})	(IPM)	ap	ae	(min^{-1})	(IPM)	ap	ae	(min^{-1})	(IPM)	ap	ae
8	.315	75	2.953	8000	94.5	.031	.002–.012	3200	30.3	.031	.002–.012	16000	189.0	.031	.002–.012
10	.394	85	3.346	6400	74.8	.033	.002–.012	2500	23.6	.033	.002–.012	13000	153.5	.033	.002–.012
10	.394	75	2.953	6400	74.8	.031	.002–.012	2500	23.6	.031	.002–.012	13000	153.5	.031	.002–.012
12	.472	100	3.937	5300	63.0	.035	.002–.012	2100	19.7	.035	.002–.012	11000	129.9	.035	.002–.012

Note 1) SMART MIRACLE coating has very low electrical conductivity; therefore, an external contact type of tool setter (electric transmitted) may not work.

When measuring the tool length, an internal contact/non-electric type or laser tool setter is recommended.

Note 2) Recommended for finish cutting only.

Note 3) The tool contact part differs between the nose radius and tangential form radius depending on machining geometries and tilt angles. Select suitable cutting conditions according to tool contact parts.

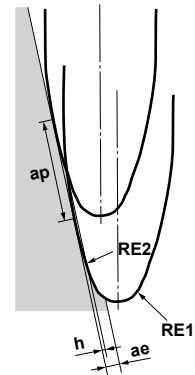

Depth of Cut Calculation Table Based on Tangential Form Radius (RE2) and Cusp Height (h)

Order Number	RE2	Cusp Height h	.000004	.000012	.000020	.000031	.000039	.000118	.000197	.000315
VQT6URR020R075S08	2.953 (75mm)	Depth of Cut ae	.0096	.0167	.0216	.0273	.0305	.0528	.0682	.0863
VQT6URR030R075S10	2.953 (75mm)		.0096	.0167	.0216	.0273	.0305	.0528	.0682	.0863
VQT6URR020R085S10	3.346 (85mm)		.0103	.0178	.0230	.0291	.0325	.0562	.0726	.0918
VQT6URR040R100S12	3.937 (100mm)		.0111	.0193	.0249	.0315	.0352	.0610	.0787	.0996

Recommended Cutting Conditions

Fillet Milling with the Use of the Nose Radius (RE1)

(inch)

Workpiece Material				Mild Steels ($\leq 180\text{HB}$) Carbon Steels, Alloy Steels (180–280HB)				Austenitic Stainless Steels ($\leq 200\text{HB}$) Titanium Alloys				Aluminum Alloys (Si < 5%)			
				Revolution (min^{-1})	Feed Rate (IPM)	Depth of Cut ap	Depth of Cut ae	Revolution (min^{-1})	Feed Rate (IPM)	Depth of Cut ap	Depth of Cut ae	Revolution (min^{-1})	Feed Rate (IPM)	Depth of Cut ap	Depth of Cut ae
DC		RE1													
mm	inch	mm	inch												
8	.315	2	.079	16000	94.5	.016	.039	6400	22.8	.016	.039	32000	189.0	.016	.039
10	.394	2	.079	16000	94.5	.016	.039	6400	22.8	.016	.039	32000	189.0	.016	.039
10	.394	3	.118	11000	66.9	.024	.059	4200	15.0	.024	.059	21000	126.0	.024	.059
12	.472	4	.157	8000	47.2	.031	.079	3200	11.4	.031	.079	16000	94.5	.031	.079

Note 1) SMART MIRACLE coating has very low electrical conductivity; therefore, an external contact type of tool setter (electric transmitted) may not work.

When measuring the tool length, an internal contact/non-electric type or laser tool setter is recommended.

Note 2) Recommended for finish cutting only.

Note 3) The tool contact part differs between the nose radius and tangential form radius depending on machining geometries and tilt angles. Select suitable cutting conditions according to tool contact parts.

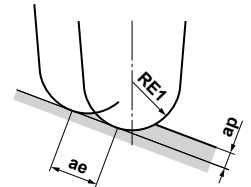

Cutting Performance

Fillet Milling of Titanium Alloy

Achieves a quality surface finish with no chipping on the cutting edge.

Solid End Mills

VQT6UR



Conventional



Surface

Cutting Edge

<Cutting Conditions>

Workpiece Material : Ti-6Al-4V

Tool : VQT6URR020R085S10

Cutting Speed : $vc=260 \text{ SFM}$

Revolution : $n=6770 \text{ min}^{-1}$

Feed per Tooth : $fz=.001 \text{ IPT}$

Depth of Cut : $ap=.039 \text{ inch}$

Cutting Mode : External Coolant (Emulsion)

Machine : 5-axis MC (HSK63)

Cutting Performance

Deep Wall Machining of Titanium Alloy

High efficiency machining is achieved while maintaining quality of machined surface.

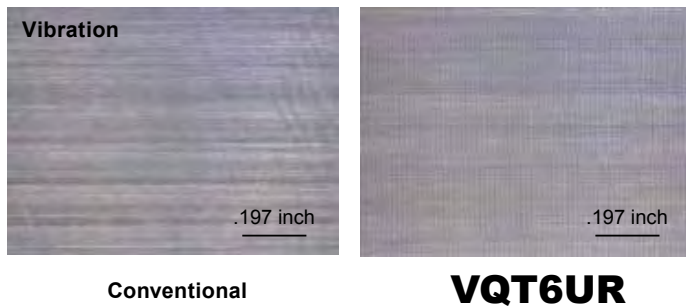
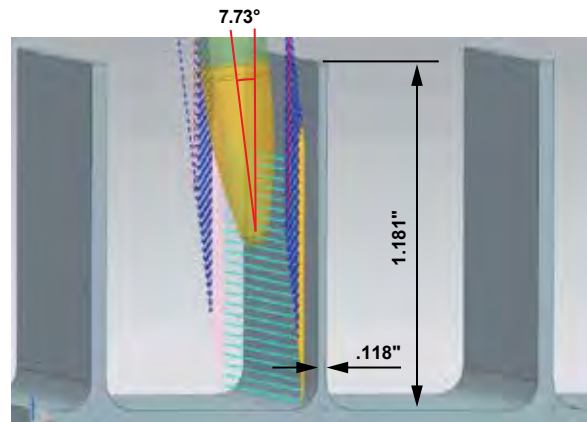
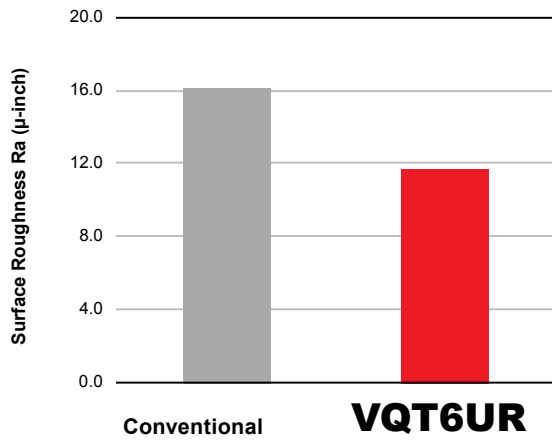

<Cutting Conditions>

Workpiece Material : Ti-6Al-4V
 Tool : VQT6URR020R085S10
 Revolution : $n=2546 \text{ min}^{-1}$
 Feed per Tooth : $fz=.001 \text{ IPT}$
 Depth of Cut : $ap=.059 \text{ inch}$
 : $ae=.012 \text{ inch}$
 Tilt Angle : 7.73°
 Cutting Mode : Side Milling
 External Coolant (Emulsion)
 Machine : 5-axis MC (HSK63)

Comparison of Tool Life in Titanium Alloy

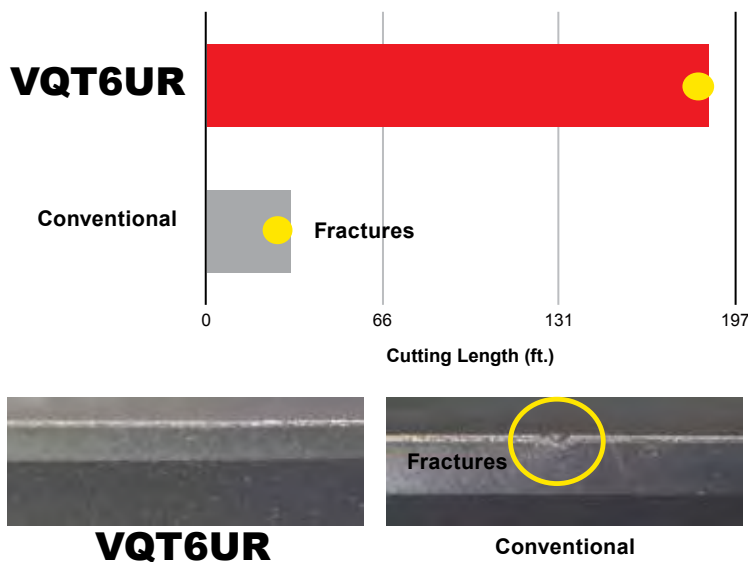

<Cutting Conditions>

Workpiece Material : Ti-6Al-4V
 Tool : VQT6URR020R085S10
 Revolution : $n=2546 \text{ min}^{-1}$
 Feed per Tooth : $fz=.001 \text{ IPT}$
 Depth of Cut : $ap=.157 \text{ inch}$
 : $ae=.012 \text{ inch}$
 Tilt Angle : 8°
 Overhang Length : 1.575 inch
 Cutting Mode : External Coolant (Emulsion)
 Machine : 5-axis MC (HSK63)



Machining Example

Blade Surface Machining

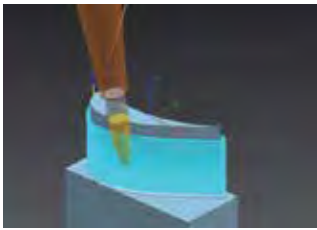

<Cutting Conditions>

Workpiece Material : Ti-6Al-4V
 Tool : VQT6URR020R085S10
 Cutting Speed : vc=395 SFM
 Feed per Rev. : vf= 36.22 IPM
 Depth of Cut : ap=.056 inch
 : ae= .008 inch
 Tilt Angle : 10°
 Cutting Mode : External Coolant
 (Emulsion)
 Machine : 5-axisl MC (HSK63)

Fillet Milling

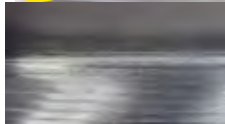
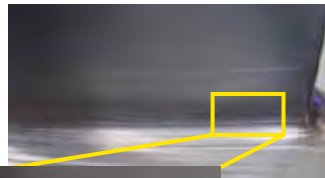
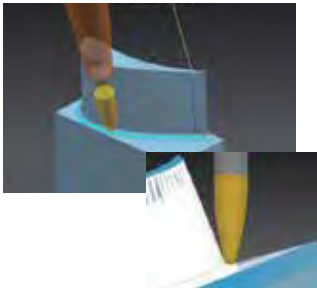

<Cutting Conditions>

Workpiece Material : Ti-6Al-4V
 Tool : VQT6URR020R085S10
 Cutting Speed : vc=260 SFM
 Feed per Rev. : vf= 29.92 IPM
 Depth of Cut : ap= .009 inch
 : ae= .008 inch
 Tilt Angle : 20°
 Cutting Mode : External Coolant
 (Emulsion)
 Machine : 5-axisl MC (HSK63)

PRODUCT EXTENSION

DIA  **EDGE**

SMART MIRACLE



REVOLUTIONARY PERFORMANCE
for difficult-to-cut materials

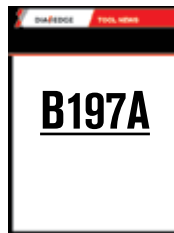

Solid End
Mills



VQMHV

End mill, Medium cut length, 4 flute, Irregular helix flutes

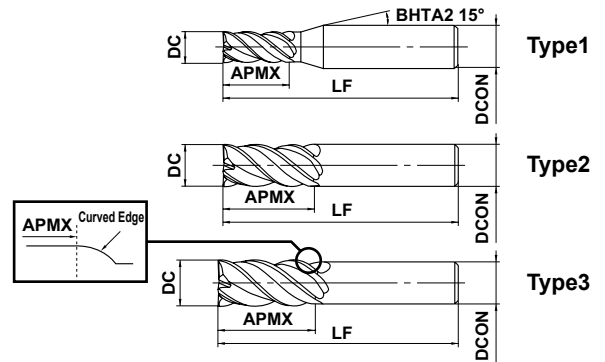

	DC ≤ 12	DC > 12			
	$\begin{matrix} 0 \\ -0.020 \end{matrix}$	$\begin{matrix} 0 \\ -0.030 \end{matrix}$			
	4 ≤ DCON ≤ 6	8 ≤ DCON ≤ 10	12 ≤ DCON ≤ 16	20 ≤ DCON ≤ 25	
	$\begin{matrix} 0 \\ -0.008 \end{matrix}$	$\begin{matrix} 0 \\ -0.009 \end{matrix}$	$\begin{matrix} 0 \\ -0.011 \end{matrix}$	$\begin{matrix} 0 \\ -0.013 \end{matrix}$	

● SMART MIRACLE vibration control end mills for reduced chattering and for delivering stable performance on difficult-to-cut materials and long overhang applications.

(mm)

Order Number	DC	APMX	LF	DCON	* No. F	Stock	Type
NEW VQMHVD0100	1	2	45	4	4	●	1
NEW VQMHVD0150	1.5	3	45	4	4	●	1
VQMHVD0200	2	4	45	4	4	●	1
VQMHVD0250	2.5	5	45	4	4	●	1
VQMHVD0300	3	8	45	6	4	●	1
VQMHVD0350	3.5	8	45	6	4	●	1
VQMHVD0400	4	11	45	6	4	●	1
VQMHVD0500	5	13	50	6	4	●	1
VQMHVD0600	6	13	50	6	4	●	2
VQMHVD0700	7	19	60	8	4	●	1
VQMHVD0800	8	19	60	8	4	●	2
VQMHVD0900	9	22	70	10	4	●	1
VQMHVD0900S08	9	22	75	8	4	●	3
VQMHVD1000	10	22	70	10	4	●	2
VQMHVD1000S08	10	22	100	8	4	●	3
VQMHVD1100	11	26	75	12	4	●	1
VQMHVD1100S10	11	26	100	10	4	●	3
VQMHVD1200	12	26	75	12	4	●	2
VQMHVD1200S10	12	26	110	10	4	●	3
VQMHVD1300	13	26	75	12	4	★	3
VQMHVD1300S12	13	26	110	12	4	★	3
VQMHVD1400	14	30	90	16	4	★	1
VQMHVD1400S12	14	32	130	12	4	★	3
VQMHVD1600	16	35	90	16	4	★	2
VQMHVD1800	18	40	100	16	4	★	3
VQMHVD1800S16	18	42	150	16	4	★	3
VQMHVD2000	20	45	110	20	4	★	2
VQMHVD2500	25	55	125	25	4	★	2

(Note 1) SMART MIRACLE coating has reduced electric conductivity; therefore an external contact type (electric transmitted) tool setter may not work. When measuring the tool length, please use an internal contact type (non-electricity type) tool setter or a laser type tool setter.

* Number of Flutes

* See Index on page 4 for table icon reference. (●, ★, □)

End mill, Semi-long cut length, 4 flute, Irregular helix flutes

VQJHV

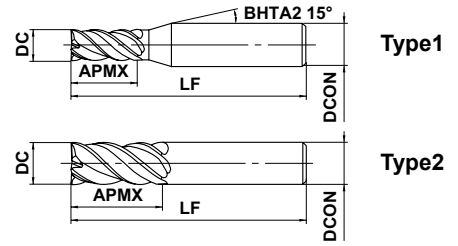

	DC ≤ 12	DC > 12			
	0 - 0.020	0 - 0.030			
	4 ≤ DCON ≤ 6	8 ≤ DCON ≤ 10	12 ≤ DCON ≤ 16	DCON = 20	
	0 - 0.008	0 - 0.009	0 - 0.011	0 - 0.013	

- SMART MIRACLE vibration control end mills for reduced chattering and for delivering stable performance on difficult-to-cut materials and long overhang applications.

(mm)

Order Number	DC	APMX	LF	DCON	No. F *	Stock	Type
NEW VQJHVD0100	1	4	45	4	4	●	1
NEW VQJHVD0150	1.5	6	45	4	4	●	1
VQJHVD0200	2	8	60	6	4	●	1
VQJHVD0250	2.5	10	60	6	4	●	1
VQJHVD0300	3	12	60	6	4	●	1
VQJHVD0350	3.5	14	60	6	4	●	1
VQJHVD0400	4	16	60	6	4	●	1
VQJHVD0450	4.5	18	60	6	4	●	1
VQJHVD0500	5	20	60	6	4	●	1
VQJHVD0600	6	24	60	6	4	●	2
VQJHVD0700	7	25	80	8	4	●	1
VQJHVD0800	8	28	80	8	4	●	2
VQJHVD0900	9	32	90	10	4	●	1
VQJHVD1000	10	35	90	10	4	●	2
VQJHVD1200	12	40	100	12	4	●	2
VQJHVD1600	16	55	125	16	4	★	2
VQJHVD2000	20	70	140	20	4	★	2

(Note 1) SMART MIRACLE coating has reduced electric conductivity; therefore an external contact type (electric transmitted) tool setter may not work. When measuring the tool length, please use an internal contact type (non-electricity type) tool setter or a laser type tool setter.

* Number of Flutes

Solid End Mills

PRODUCT EXTENSION



DF2XLBF DF SERIES

DIAMOND COATED END MILLS
for graphites & finishing

Plane Surface Comparison (Graphite ISO-63)

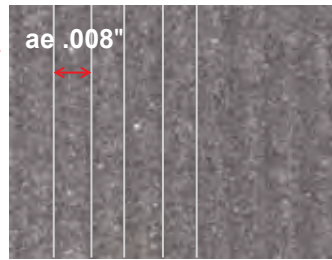

The regular cutter path guarantees excellent sharpness.

DF2XLBF

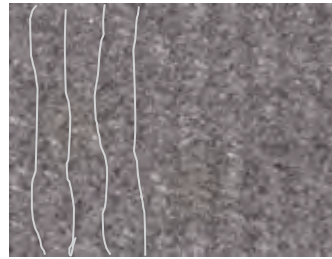

Poor sharpness can cause the cutter path to be crushed.

Conventional

End Cutting Edge Geometry



Crystallized Diamond Coating

Optimization of the coating film provides even higher sharpness.



B179A-F

Seamless Cutting Edge

Outstanding finishes are possible even for wall surface machining using minor cutting edges.

Ball nose, Medium cut length,
2 flute, Long neck, For graphites

NEW

DF2XLBF (For Finishing)

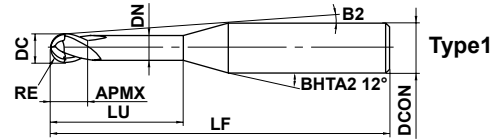

R	0.3 ≤ RE ≤ 1	1.5 ≤ RE			
	±0.005	±0.01			
h5	DCON=4				
	0	-0.008			

Effective Length for Inclined Angle

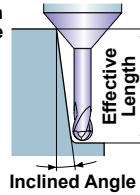

● Diamond coated long-neck ball end mills are ideal for finished surfaces of non-ferrous metals.

(mm)

Order Number	RE	DC	APMX	LU	DN	B2	LF	DCON	No.F.*	Stock	Type	Effective Length for Inclined Angle			
												30°	1°	2°	3°
DF2XLBFR0030N100	0.3	0.6	0.45	10	0.57	5.5°	50	4	2	●	1	10.4	10.9	11.9	13.2
DF2XLBFR0050N120	0.5	1	1.5	12	0.86	4.6°	50	4	2	●	1	12.6	13.2	14.4	15.9
DF2XLBFR0050N160	0.5	1	1.5	16	0.86	3.8°	50	4	2	●	1	16.8	17.5	19.2	21.3
DF2XLBFR0050N200	0.5	1	1.5	20	0.86	3.2°	50	4	2	●	1	21	21.9	24	26.6
DF2XLBFR0100N160	1	2	3	16	1.86	2.9°	50	4	2	●	1	16.7	17.4	19	*
DF2XLBFR0100N200	1	2	3	20	1.86	2.4°	50	4	2	●	1	20.9	21.8	23.9	*
DF2XLBFR0150N160	1.5	3	4.5	16	2.86	1.7°	50	4	2	●	1	16.7	17.3	18.9	20.8
DF2XLBFR0150N200	1.5	3	4.5	20	2.86	1.4°	50	4	2	●	1	20.8	21.7	23.7	26.1

* Number of Flutes

* No Interference

Application Example

Tool Life Comparison (Reference Surface Roughness)

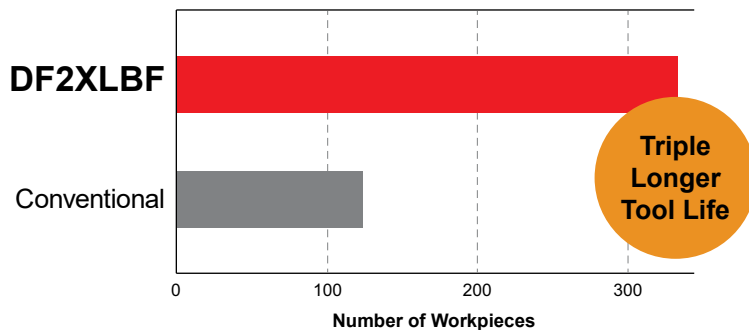

Comparison of Surface Roughness

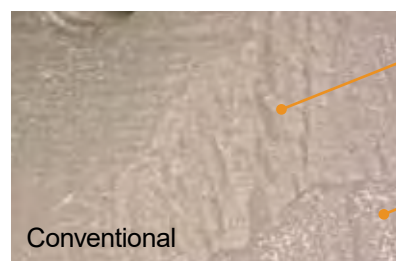

* See Index on page 4 for table icon reference. (●, ★, □)

PRODUCT EXTENSION

DIA  **EDGE**

IMPACT MIRACLE



REVOLUTIONARY HARDEN STEELS
new coating provides
longer life



B231A

P H

Ball nose, Short cut length, 2 flute, Short shank

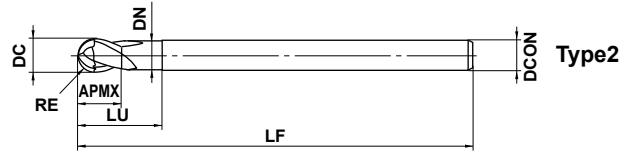
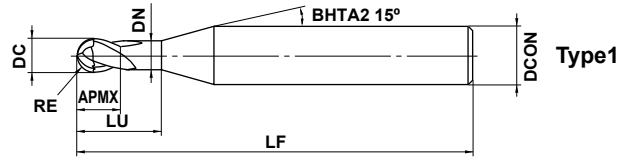

R	RE ≤ 6				
	±0.005				
h5	4 ≤ DCON ≤ 6	8 ≤ DCON ≤ 10	DCON = 12		
	0 - 0.005	0 - 0.006	0 - 0.008		

- Optimization of the cutting edge curve, helix angle, and rake angle have improved the edge strength at all areas of the ball blades.

(mm)										
Order Number	RE	DC	APMX	LU	DN	LF	DCON	No.F	* Stock	Type
VFR2SSBR0050S04	0.5	1	1	2	0.94	40	4	2	●	1
VFR2SSBR0050	0.5	1	1	2	0.94	40	6	2	●	1
VFR2SSBR0075S04	0.75	1.5	1.5	3	1.44	40	4	2	●	1
VFR2SSBR0075	0.75	1.5	1.5	3	1.44	40	6	2	●	1
VFR2SSBR0100	1	2	2	4	1.9	45	6	2	●	1
VFR2SSBR0150	1.5	3	3	6	2.9	45	6	2	●	1
VFR2SSBR0200	2	4	4	8	3.9	45	6	2	●	1
VFR2SSBR0250	2.5	5	5	10	4.9	50	6	2	●	1
VFR2SSBR0300	3	6	6	12	5.85	50	6	2	●	2
VFR2SSBR0400	4	8	8	14	7.85	60	8	2	●	2
VFR2SSBR0500	5	10	10	18	9.7	70	10	2	●	2
VFR2SSBR0600	6	12	12	22	11.7	75	12	2	●	2

* Number of Flutes

Solid End Mills

PRODUCT EXTENSION

DIA  **EDGE**

iMX SERIES



EXCHANGEABLE HEAD
End Mills

World First!*
"Carbide" + "Carbide"
(Head) (Holder)
Double Face Contact Type



*According to our own research on exchangeable head end mills.

Ball nose head, 2 flute, For hardened steels

NEW iMX-B2S

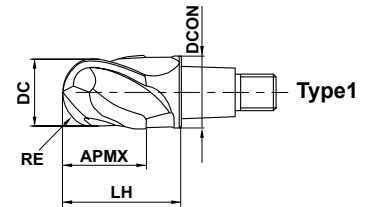

R	RE ≥ 8				
	±0.020				

- Ideal for machining with long overhangs.

(mm)

Order Number	RE	DC	APMX	LH	DCON	*1 No.F	Grade	Type
							EP8110	
IMX16B2S16016	8	16	16	24	15.5	2	●	1
IMX20B2S20020	10	20	20	30	19.5	2	●	1

*1 Number of Flutes

(Note 1) The fastening size of the holder and head should be the same.

Ball nose head, 4 flute, For hardened steels

NEW iMX-B4S

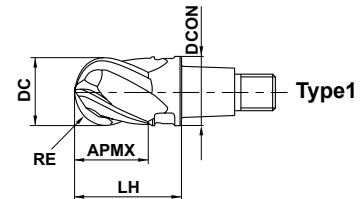

R	RE ≥ 8				
	±0.020				

- High efficiency machining is realized even with machining using the tip.

(mm)

Order Number	RE	DC	APMX	LH	DCON	No.F	Grade	Type
							EP8110	
IMX16B4S16016	8	16	16	24	15.5	4	●	1
IMX20B4S20020	10	20	20	30	19.5	4	●	1

(Note 1) The fastening size of the holder and head should be the same.

* Number of Flutes

Milling

TOOLING SPECIALISTS

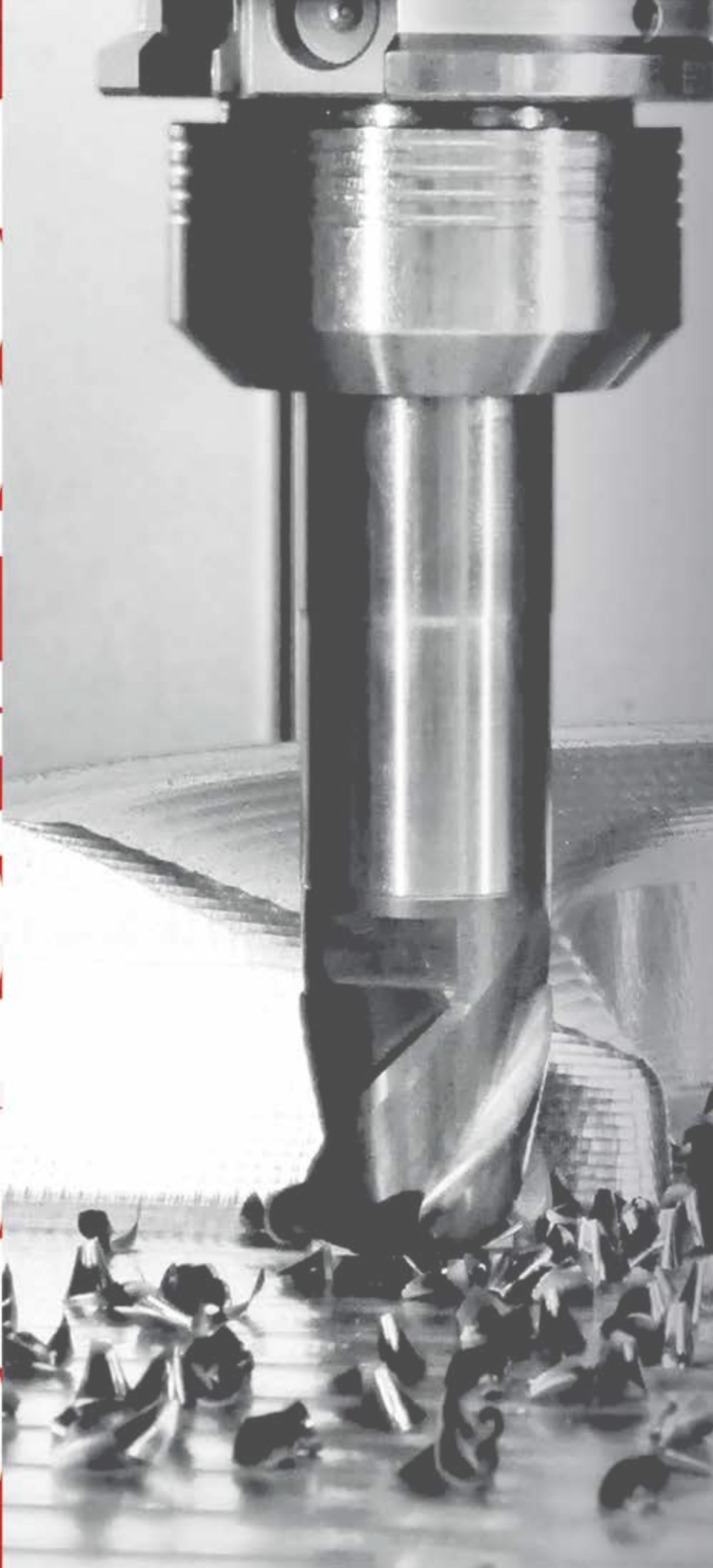

NEW PRODUCT

DIA  **EDGE**

VPX SERIES



MULTI-FUNCTIONAL CUTTER
for high efficiency machining

VPX
Series

Our thoroughly tested design will completely change how you see the tangential cutter.



POSSIBLE MACHINING FEED PER TOOTH (using AISI 4140)

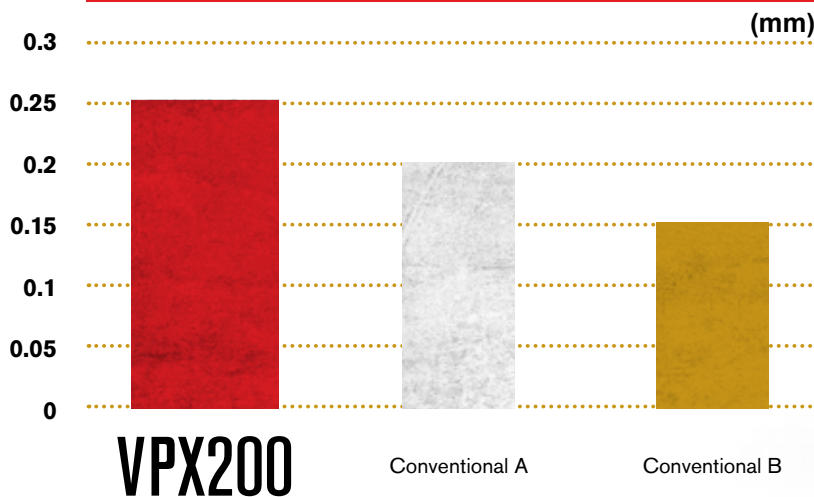

ABOUT

PURSUING THE TOUGH MACHINING CHARACTERISTIC OF TANGENTIAL BLADE INSERTS.

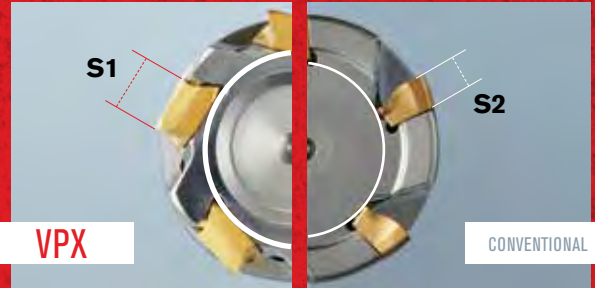

By arranging the inserts tangentially, high holder rigidity is secured. Also, because the part subjected to the highest loads during machining is larger ($S1 > S2$), it has great fracture resistance and can be used without worry for high efficiency machining.



The wide seating surfaces provided allow the insert to clamp on more firmly. Suppresses deviation of the insert caused by vibrations during machining.



Comments from developers

DURABILITY BORN THROUGH REPEATED DESTRUCTIVE TESTS.

In order to improve durability, we began development by first applying a load to the cutter until it broke. After analyzing the reasons it broke, we produced an improved version then broke that as well. We repeated this process until we were satisfied with the results. As a result of this pursuit of durability through thorough destructive tests, we were able to come up with a cutter that is ideal for unmanned operation and high efficiency machining.



ABOUT

SOLVING PROBLEMS AS A MULTI-FUNCTIONAL CUTTER.



Comments from developers

THROUGH TRIAL AND ERROR, WE'VE SOLVED INDUSTRY PROBLEMS.

The surface-to-surface balance of the insert is what allows the multi-functionality of ramping to be achieved, while maintaining the good chip ejection and the cutting performance inherent to tangential blade cutters. Most tangential blade cutters must be changed out with dedicated inserts for ramping. We made it a priority to unify these two styles of inserts, so as to avoid the trouble of managing two sets of inserts, and prevent installation mistakes.

By focusing on the surface design of these new inserts, and through repeated trial and error, we were able to resolve one of the major issues in the industry.

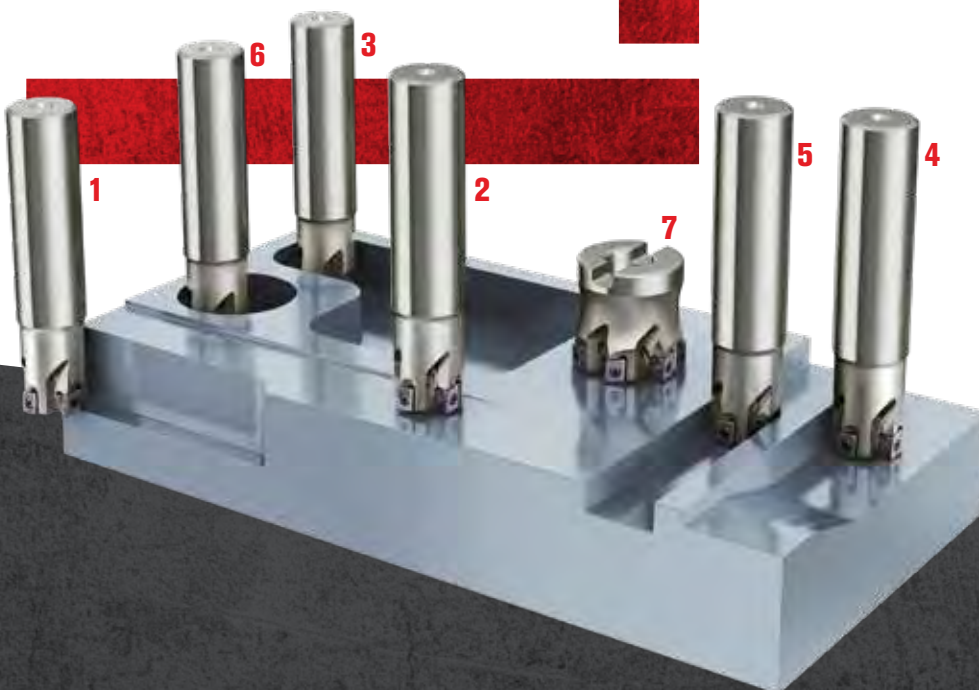

Different types of milling cover a wide variety of applications.

- 1 Shoulder Milling
- 2 Ramping
- 3 Pocket Milling
- 4 3-D Profile Milling
- 5 Slot Milling
- 6 Helical Milling
- 7 Face Milling

Inserts

Double-sided insert that has revolutionized tangential insert machining.

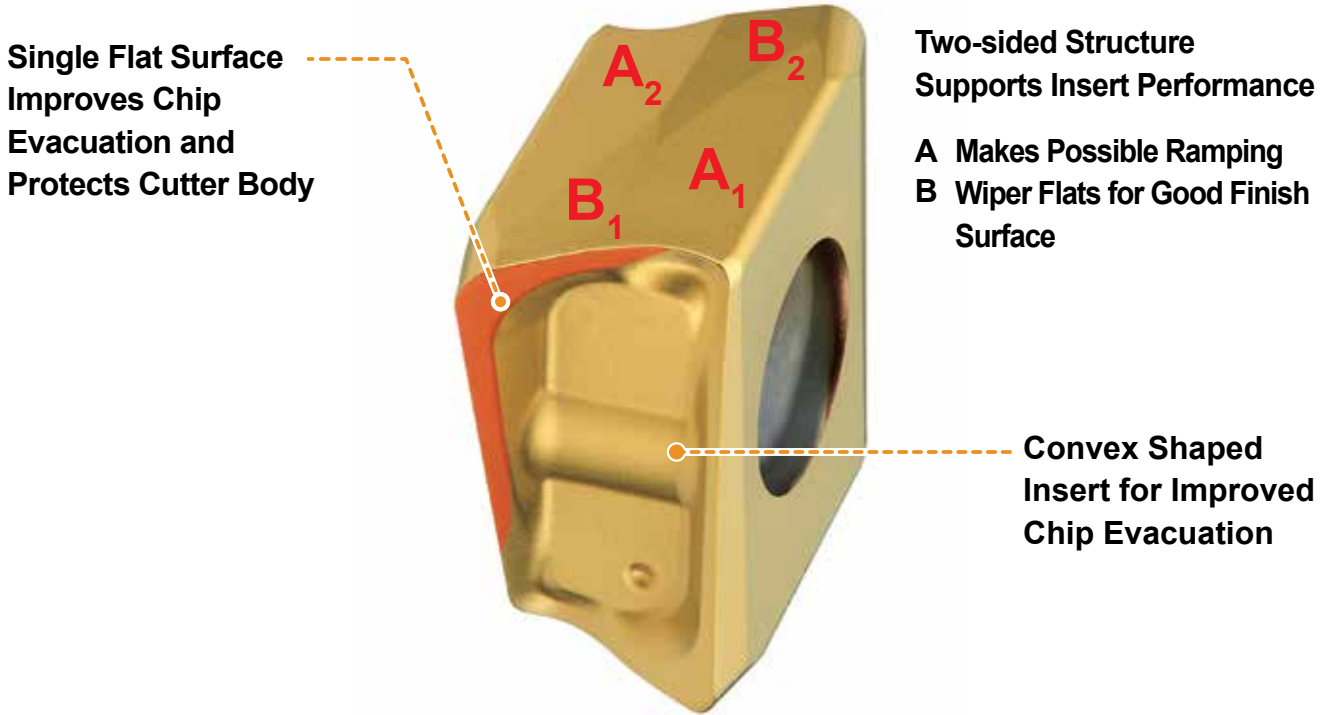

Comments from developers

An insert shape that was possible to design, but difficult to commercialize.

The shape of the insert makes it tough while still enabling versatility. We have conquered many challenges from prototype to production--a testimony to Mitsubishi Materials commitment to precision.

Good Wall Surface Finish

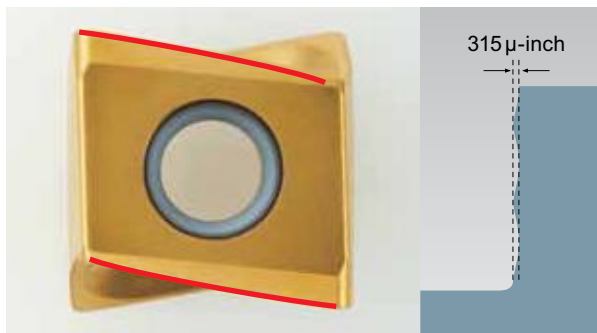

Large Wiper Flats Achieve a Better Finish Surface

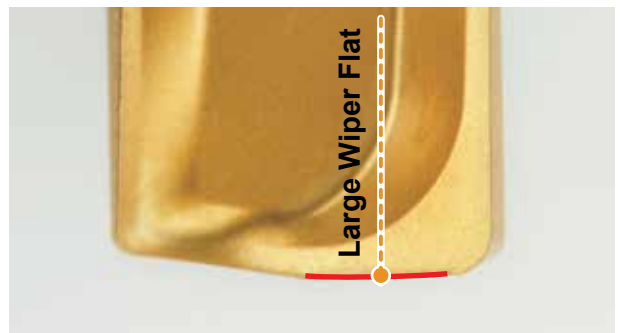

Insert Grades for a Wide Range of Materials

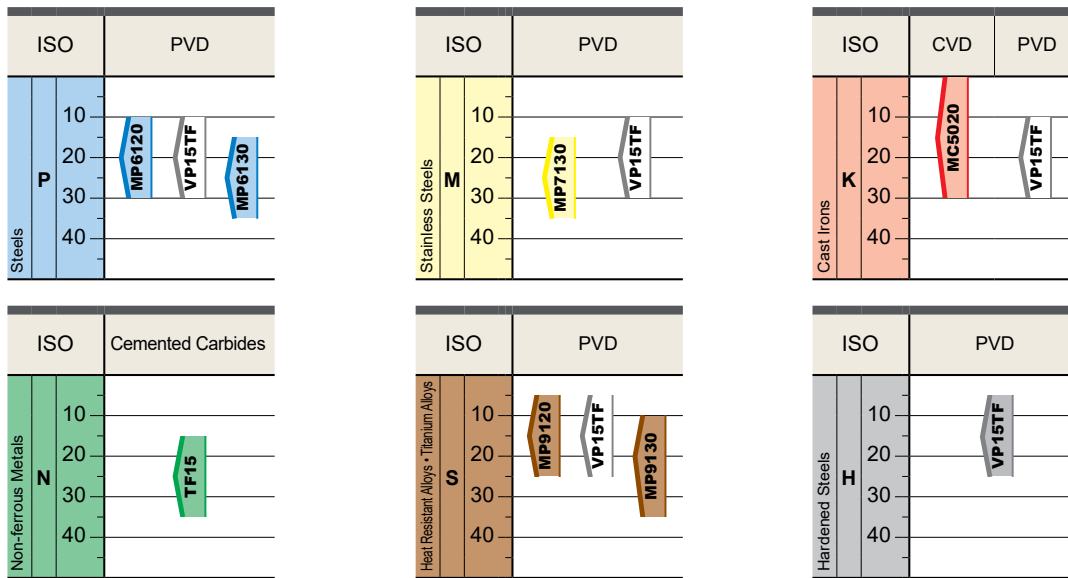

MP6100/MP7100/MP9100 Series

TOUGH-Σ Technology

A fusion of the separate coating technologies; PVD and multilayering provides extra toughness.

Base Layer High Al-(Al, Ti)N

The new technology Al-(Al, Ti)N coating provides stabilisation of the high hardness phase and succeeds in dramatically improving wear, crater and welding resistance.

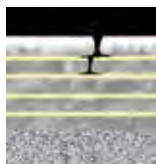

Multilayering of the coating prevents any cracks penetrating through to the substrate.

*Graphical Representation.

Al-Ti-Cr-N Based PVD Coating

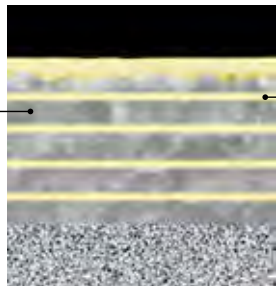

*Graphical Representation.

Best Layer of Each Workpiece Material

P	(Al,Cr)N	
	Tough! Thermal Cracks	Thermal Cracks
M	TiN	
	Tough! Notching	Notching
S	CrN	
	Tough! Resistant Chipping	Welding by Chipping

CVD Coating MC5020

First recommendation for cast irons milling.

MC5020 has excellent wear resistance and also controls thermal cracking and chipping that are common when machining ductile cast irons.

Comparison of Coating Surface



Conventional Coating

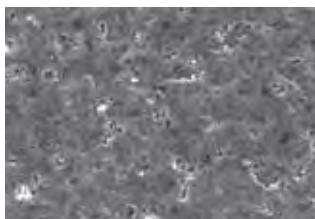

Black Super-smooth Coating

Black Super-smooth Coating

Black super-smooth coating prevents abnormal damage such as weld chipping.

* See Index on page 4 for table icon reference. (●, ★, □)

VPX200 (Inch)

MULTI-FUNCTIONAL MILLING



Fig.1

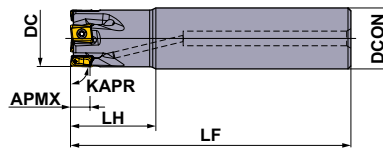

Fig.2

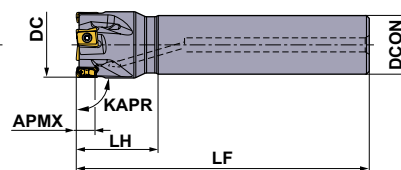

Fig.3

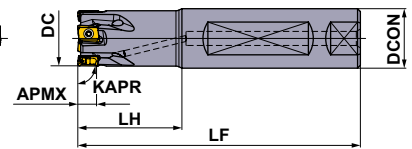
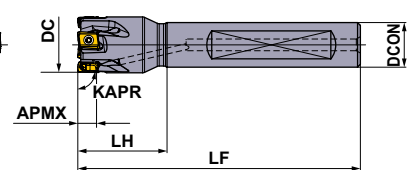

Fig.4



Shank Type

With Coolant Hole

Right hand tool holder only.

(inch)

DC	Order Number	Stock	* No.T	DCON	LF	LH	APMX	RMPX	Max. Spindle Speed (min ⁻¹)	WT (lbs)	Fig.	Insert Type	
												R	Icon
.625	VPX200UR1002FA10S	●	2	.625	3.625	1.250	.315	1.87°	38100	.3	3	LOGU09	
.625	VPX200UR1002SA10S	●	2	.625	3.625	1.250	.315	1.87°	38100	.3	1	LOGU09	
.625	VPX200UR1002SA10L	●	2	.625	6.000	1.500	.315	1.87°	38100	.5	1	LOGU09	
.750	VPX200UR1202FA10S	●	2	.625	4.375	1.250	.315	1.43°	34200	.3	4	LOGU09	
.750	VPX200UR1202SA10S	●	2	.625	4.375	1.250	.315	1.43°	34200	.4	2	LOGU09	
.750	VPX200UR1203FA10S	●	3	.625	4.375	1.250	.315	1.43°	34200	.3	4	LOGU09	
.750	VPX200UR1203SA10S	●	3	.625	4.375	1.250	.315	1.43°	34200	.3	2	LOGU09	
.750	VPX200UR1202FA12S	●	2	.750	4.375	1.500	.315	1.43°	34200	.4	3	LOGU09	
.750	VPX200UR1202SA12S	●	2	.750	4.375	1.500	.315	1.43°	34200	.5	1	LOGU09	
.750	VPX200UR1203FA12S	●	3	.750	4.375	1.500	.315	1.43°	34200	.4	3	LOGU09	
.750	VPX200UR1203SA12S	●	3	.750	4.375	1.500	.315	1.43°	34200	.5	1	LOGU09	
.750	VPX200UR1202SA12L	●	2	.750	7.250	2.000	.315	1.43°	34200	.8	1	LOGU09	
.875	VPX200UR1402SA12L	●	2	.750	7.250	1.500	.315	1.14°	31200	.8	2	LOGU09	
1.000	VPX200UR1603FA12S	●	3	.750	4.750	1.500	.315	.95°	28800	.6	4	LOGU09	
1.000	VPX200UR1603SA12S	●	3	.750	4.750	1.500	.315	.95°	28800	.6	2	LOGU09	
1.000	VPX200UR1604FA12S	●	4	.750	4.750	1.500	.315	.95°	28800	.6	4	LOGU09	
1.000	VPX200UR1604SA12S	●	4	.750	4.750	1.500	.315	.95°	28800	.6	2	LOGU09	
1.000	VPX200UR1603FA12L	●	3	.750	8.500	1.500	.315	.95°	28800	1.0	2	LOGU09	
1.000	VPX200UR1603FA16S	●	3	1.000	4.750	1.750	.315	.95°	28800	.9	3	LOGU09	
1.000	VPX200UR1603SA16S	●	3	1.000	4.750	1.750	.315	.95°	28800	.9	1	LOGU09	
1.000	VPX200UR1604FA16S	●	4	1.000	4.750	1.750	.315	.95°	28800	.9	3	LOGU09	
1.000	VPX200UR1604SA16S	●	4	1.000	4.750	1.750	.315	.95°	28800	.9	1	LOGU09	
1.000	VPX200UR1603SA16L	●	3	1.000	8.500	2.500	.315	.95°	28800	1.7	1	LOGU09	
1.125	VPX200UR1803SA16L	●	3	1.000	8.500	1.750	.315	.82°	26800	1.8	2	LOGU09	
1.250	VPX200UR2003FA16S	●	3	1.000	5.125	1.750	.315	.71°	25200	1.1	4	LOGU09	
1.250	VPX200UR2003SA16S	●	3	1.000	5.125	1.750	.315	.71°	25200	1.1	2	LOGU09	
1.250	VPX200UR2005FA16S	●	5	1.000	5.125	1.750	.315	.71°	25200	1.1	4	LOGU09	
1.250	VPX200UR2005SA16S	●	5	1.000	5.125	1.750	.315	.71°	25200	1.1	2	LOGU09	
1.250	VPX200UR2003SA16L	●	3	1.000	9.000	1.750	.315	.71°	25200	1.9	2	LOGU09	
1.250	VPX200UR2003FA20S	●	3	1.250	5.125	2.000	.315	.71°	25200	1.5	3	LOGU09	
1.250	VPX200UR2003SA20S	●	3	1.250	5.125	2.000	.315	.71°	25200	1.6	1	LOGU09	
1.250	VPX200UR2004FA20S	●	4	1.250	5.125	2.000	.315	.71°	25200	1.5	3	LOGU09	
1.250	VPX200UR2004SA20S	●	4	1.250	5.125	2.000	.315	.71°	25200	1.6	1	LOGU09	
1.250	VPX200UR2005FA20S	●	5	1.250	5.125	2.000	.315	.71°	25200	1.5	3	LOGU09	
1.250	VPX200UR2005SA20S	●	5	1.250	5.125	2.000	.315	.71°	25200	1.6	1	LOGU09	
1.250	VPX200UR2003SA20L	●	3	1.250	9.000	3.000	.315	.71°	25200	2.8	1	LOGU09	
1.500	VPX200UR2404FA20S	●	4	1.250	5.125	2.000	.315	.57°	22600	1.7	4	LOGU09	
1.500	VPX200UR2404SA20S	●	4	1.250	5.125	2.000	.315	.57°	22600	1.8	2	LOGU09	
1.500	VPX200UR2406FA20S	●	6	1.250	5.125	2.000	.315	.57°	22600	1.7	4	LOGU09	
1.500	VPX200UR2406SA20S	●	6	1.250	5.125	2.000	.315	.57°	22600	1.7	2	LOGU09	
1.500	VPX200UR2404SA20L	●	4	1.250	9.000	2.000	.315	.57°	22600	3.1	2	LOGU09	

Note 1) The maximum spindle speeds are set to ensure tool and insert stability.

Note 2) When using the tool at high spindle speeds, ensure that the tool and arbor are correctly balanced.

CUTTING CONDITIONS > P130-138

* Number of Teeth

* See Index on page 4 for table icon reference. (●, ★, □)

MULTI-FUNCTIONAL MILLING

VPX200 (Inch)

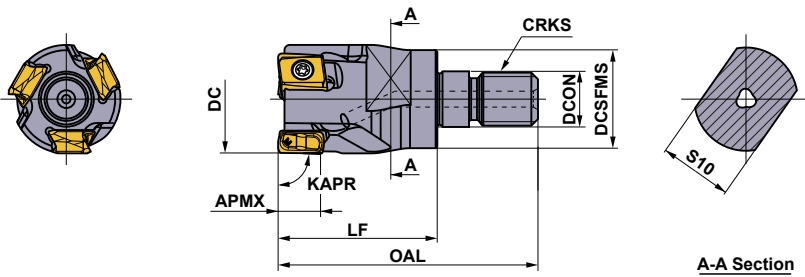

Right hand tool holder only.

Screw-in Type

With Coolant Hole

(inch)

DC	Order Number	Stock	*1 No.T	DCON	DCSFMS	OAL	LF	S10	CRKS	WT (lbs)	APMX	RMPX	
.625	VPX200UR1002AM0830	●	2	.335	.571	1.890	1.181	.394	M08	.1	.315	1.87°	LOGU09
.750	VPX200UR1202AM1030	●	2	.413	.728	1.929	1.181	.551	M10	.1	.315	1.43°	LOGU09
.750	VPX200UR1203AM1030	●	3	.413	.728	1.929	1.181	.551	M10	.1	.315	1.43°	LOGU09
.875	VPX200UR1402AM1030	●	2	.413	.728	1.929	1.181	.551	M10	.2	.315	1.14°	LOGU09
.875	VPX200UR1403AM1030	●	3	.413	.728	1.929	1.181	.551	M10	.1	.315	1.14°	LOGU09
1.000	VPX200UR1603AM1235	●	3	.492	.925	2.244	1.378	.748	M12	.2	.315	.95°	LOGU09
1.000	VPX200UR1604AM1235	●	4	.492	.925	2.244	1.378	.748	M12	.2	.315	.95°	LOGU09
1.125	VPX200UR1803AM1235	●	3	.492	.925	2.244	1.378	.748	M12	.3	.315	.82°	LOGU09
1.125	VPX200UR1804AM1235	●	4	.492	.925	2.244	1.378	.748	M12	.3	.315	.82°	LOGU09
1.250	VPX200UR2003AM1640	●	3	.669	1.122	2.480	1.575	.945	M16	.5	.315	.71°	LOGU09
1.250	VPX200UR2004AM1640	●	4	.669	1.122	2.480	1.575	.945	M16	.5	.315	.71°	LOGU09
1.250	VPX200UR2005AM1640	●	5	.669	1.122	2.480	1.575	.945	M16	.5	.315	.71°	LOGU09
1.375	VPX200UR2203AM1640	●	3	.669	1.122	2.480	1.575	.945	M16	.5	.315	.64°	LOGU09
1.375	VPX200UR2205AM1640	●	5	.669	1.122	2.480	1.575	.945	M16	.5	.315	.64°	LOGU09
1.500	VPX200UR2404AM1640	●	4	.669	1.122	2.480	1.575	.945	M16	.6	.315	.57°	LOGU09
1.500	VPX200UR2406AM1640	●	6	.669	1.122	2.480	1.575	.945	M16	.6	.315	.57°	LOGU09



* For screw-in type arbors, refer to page 126 -129.

*1 Number of Teeth

CUTTING CONDITIONS > P130-138

Spare Parts

(inch)

DC	Tool Holder Type	*		
				
		Clamp Screw	Wrench	Anti-seize Lubricant
.625	VPX200UR10	TPS27F1	TIP07F	MK1KS
.750	VPX200UR12	TPS27F1	TIP07F	MK1KS
.875	VPX200UR14	TPS27F2	TIP07F	MK1KS
1.000	VPX200UR16	TPS27F2	TIP07F	MK1KS
1.125	VPX200UR18	TPS27F2	TIP07F	MK1KS
1.250	VPX200UR20	TPS27F2	TIP07F	MK1KS
1.375	VPX200UR22	TPS27F2	TIP07F	MK1KS
1.500	VPX200UR24	TPS27F2	TIP07F	MK1KS

* Clamp Torque (lbf-in) : TPS27F1 = 8.9, TPS27F2 = 8.9

VPX200 (Inch)

MULTI-FUNCTIONAL MILLING

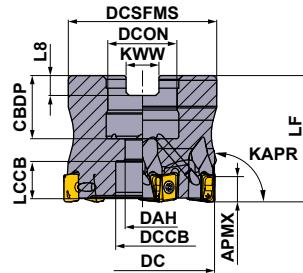

DCON	Set Bolt	Geometry
φ.500"	HSCU25011H	
φ.750"	HSCU37513H	
φ1.000"	HSCU50014H	

Arbor Type

With Coolant Hole

GAMP: -6° T: +5°
GAMF: -25° I: +4°

Right hand tool holder only.

DC=Inch size, DCON=Inch size

(inch)

DC	Order Number	Stock	* No.T	LF	DCON	WT (lbs)	APMX	RMPX	Max. Spindle Speed (min ⁻¹)	Insert Type
										R
1.250	VPX200UR1.2503SA	●	3	1.375	.500	.120	.315	.72°	25200	LOGU09
1.250	VPX200UR1.2505SA	●	5	1.375	.500	.120	.315	.72°	25200	LOGU09
1.500	VPX200UR1.5004SA	●	4	1.750	.500	.260	.315	.57°	22600	LOGU09
1.500	VPX200UR1.5006SA	●	6	1.750	.500	.250	.315	.57°	22600	LOGU09
1.500	VPX200UR1.5004AA	●	4	1.750	.750	.220	.315	.57°	22600	LOGU09
1.500	VPX200UR1.5006AA	●	6	1.750	.750	.210	.315	.57°	22600	LOGU09
2.000	VPX200UR2.0005AA	●	5	1.750	.750	.410	.315	.41°	19000	LOGU09
2.000	VPX200UR2.0007AA	●	7	1.750	.750	.410	.315	.41°	19000	LOGU09
2.500	VPX200UR2.5006CA	●	6	2.000	1.000	.740	.315	.32°	16700	LOGU09
2.500	VPX200UR2.5009CA	●	9	2.000	1.000	.740	.315	.32°	16700	LOGU09

Note 1) The maximum spindle speeds are set to ensure tool and insert stability.

Note 2) When using the tool at high spindle speeds, ensure that the tool and arbor are correctly balanced.

CUTTING CONDITIONS > P130-138

* Number of Teeth

Mounting Dimensions

(inch)

DC	Order Number	DCON	CBDP	DAH	DCCB	LCCB	DCSFMS	KWW	L8
1.250	VPX200UR1.2503SA	.500	.63	.276	.433	.304	1.125	.25	.156
1.250	VPX200UR1.2505SA	.500	.63	.276	.433	.304	1.125	.25	.156
1.500	VPX200UR1.5004SA	.500	.63	.276	.433	.679	1.438	.25	.156
1.500	VPX200UR1.5006SA	.500	.63	.276	.433	.679	1.438	.25	.156
1.500	VPX200UR1.5004AA	.750	.748	.413	.63	.561	1.438	.313	.187
1.500	VPX200UR1.5006AA	.750	.748	.413	.63	.561	1.438	.313	.187
2.000	VPX200UR2.0005AA	.750	.748	.413	.63	.561	1.75	.313	.187
2.000	VPX200UR2.0007AA	.750	.748	.413	.63	.561	1.75	.313	.187
2.500	VPX200UR2.5006CA	1.000	.945	.539	.787	.693	2.188	.375	.219
2.500	VPX200UR2.5009CA	1.000	.945	.539	.787	.693	2.188	.375	.219

Spare Parts

(inch)

DC	Tool Holder Type	* 		
		Clamp Screw	Wrench	Anti-seize Lubricant
1.250	VPX200UR1.250	TPS27F2	TIP07F	MK1KS
1.500	VPX200UR1.500	TPS27F2	TIP07F	MK1KS
2.000	VPX200UR2.000	TPS27F2	TIP07F	MK1KS
2.500	VPX200UR2.500	TPS27F2	TIP07F	MK1KS

* Clamp Torque (lbf-in) : TPS27F2 = 8.9

MULTI-FUNCTIONAL MILLING

VPX200 (Metric)

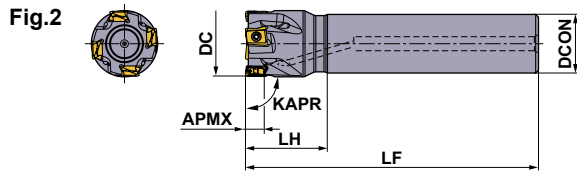
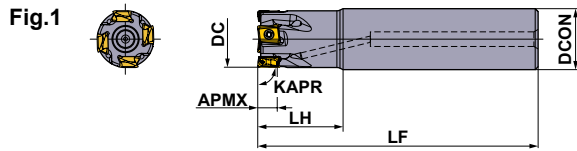

Right hand tool holder only.



Shank Type

With Coolant Hole

(mm)

DC	Order Number	Stock	* No.T	DCON	LF	LH	APMX	RMPX	Max. Spindle Speed (min ⁻¹)	WT (kg)	Fig.	Insert Type
												R
16	VPX200R1602SA16S	★	2	16	85	25	8	1.85°	37900	0.11	1	LOGU09
18	VPX200R1802SA16S	★	2	16	85	25	8	1.56°	35300	0.12	2	LOGU09
18	VPX200R1802SA16L	★	2	16	120	25	8	1.56°	35300	0.17	2	LOGU09
20	VPX200R2002SA16S	★	2	16	100	25	8	1.35°	33200	0.14	2	LOGU09
20	VPX200R2003SA16S	★	3	16	100	25	8	1.35°	33200	0.14	2	LOGU09
20	VPX200R2002SA20S	★	2	20	100	30	8	1.35°	33200	0.21	1	LOGU09
20	VPX200R2003SA20S	★	3	20	100	30	8	1.35°	33200	0.21	1	LOGU09
20	VPX200R2002SA20L	★	2	20	150	60	8	1.35°	33200	0.32	1	LOGU09
22	VPX200R2202SA20S	★	2	20	115	30	8	1.16°	31400	0.26	2	LOGU09
22	VPX200R2203SA20S	★	3	20	115	30	8	1.16°	31400	0.25	2	LOGU09
22	VPX200R2202SA20L	★	2	20	150	30	8	1.16°	31400	0.34	2	LOGU09
25	VPX200R2503SA20S	★	3	20	115	30	8	0.97°	29000	0.26	2	LOGU09
25	VPX200R2504SA20S	★	4	20	115	30	8	0.97°	29000	0.26	2	LOGU09
25	VPX200R2503SA25S	★	3	25	115	35	8	0.97°	29000	0.39	1	LOGU09
25	VPX200R2504SA25S	★	4	25	115	35	8	0.97°	29000	0.39	1	LOGU09
25	VPX200R2503SA25L	★	3	25	170	70	8	0.97°	29000	0.57	1	LOGU09
28	VPX200R2803SA25S	★	3	25	115	35	8	0.84°	27200	0.41	2	LOGU09
28	VPX200R2804SA25S	★	4	25	115	35	8	0.84°	27200	0.41	2	LOGU09
28	VPX200R2803SA25L	★	3	25	170	35	8	0.84°	27200	0.61	2	LOGU09
30	VPX200R3003SA25S	★	3	25	125	35	8	0.77°	26000	0.46	2	LOGU09
30	VPX200R3004SA25S	★	4	25	125	35	8	0.77°	26000	0.46	2	LOGU09
32	VPX200R3203SA32S	★	3	32	125	45	8	0.71°	25100	0.70	1	LOGU09
32	VPX200R3204SA32S	★	4	32	125	45	8	0.71°	25100	0.70	1	LOGU09
32	VPX200R3205SA32S	★	5	32	125	45	8	0.71°	25100	0.70	1	LOGU09
32	VPX200R3203SA32L	★	3	32	190	90	8	0.71°	25100	1.06	1	LOGU09
35	VPX200R3503SA32L	★	3	32	190	45	8	0.63°	23800	1.14	2	LOGU09
40	VPX200R4004SA32S	★	4	32	125	45	8	0.54°	22000	0.81	2	LOGU09
40	VPX200R4006SA32S	★	6	32	125	45	8	0.54°	22000	0.80	2	LOGU09
50	VPX200R5005SA32S	★	5	32	125	45	8	0.42°	19200	0.91	2	LOGU09
50	VPX200R5007SA32S	★	7	32	125	45	8	0.42°	19200	0.91	2	LOGU09

Note 1) The maximum spindle speeds are set to ensure tool and insert stability.

Note 2) When using the tool at high spindle speeds, ensure that the tool and arbor are correctly balanced.

CUTTING CONDITIONS > P130-138

* Number of Teeth

Milling Tool
Inserts

VPX SERIES

VPX200

(Metric)



MULTI-FUNCTIONAL MILLING

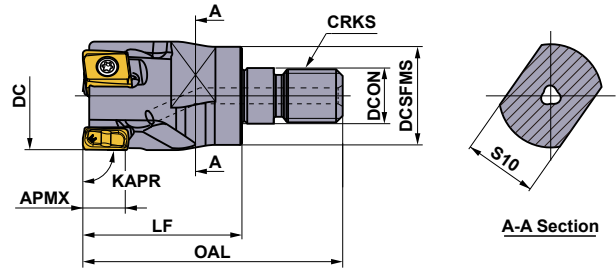
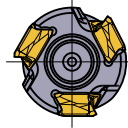

Right hand tool holder only.

Screw-in Type

With Coolant Hole

(mm)

DC	Order Number	Stock	*1 No.T	DCON	DCSFMS	OAL	LF	S10	CRKS	WT (kg)	APMX	RMPX	
16	VPX200R1602AM0830	★	2	8.5	14.5	48	30	10	M08	0.03	8	1.85°	LOGU09
18	VPX200R1802AM0830	★	2	8.5	14.5	48	30	10	M08	0.04	8	1.56°	LOGU09
20	VPX200R2002AM1030	★	2	10.5	18.5	49	30	14	M10	0.06	8	1.35°	LOGU09
20	VPX200R2003AM1030	★	3	10.5	18.5	49	30	14	M10	0.06	8	1.35°	LOGU09
22	VPX200R2202AM1030	★	2	10.5	18.5	49	30	14	M10	0.06	8	1.16°	LOGU09
22	VPX200R2203AM1030	★	3	10.5	18.5	49	30	14	M10	0.06	8	1.16°	LOGU09
25	VPX200R2503AM1235	★	3	12.5	23.5	57	35	19	M12	0.11	8	0.97°	LOGU09
25	VPX200R2504AM1235	★	4	12.5	23.5	57	35	19	M12	0.11	8	0.97°	LOGU09
32	VPX200R3203AM1640	★	3	17	28.5	63	40	24	M16	0.21	8	0.71°	LOGU09
32	VPX200R3204AM1640	★	4	17	28.5	63	40	24	M16	0.21	8	0.71°	LOGU09
32	VPX200R3205AM1640	★	5	17	28.5	63	40	24	M16	0.21	8	0.71°	LOGU09
35	VPX200R3503AM1640	★	3	17	28.5	63	40	24	M16	0.24	8	0.63°	LOGU09
35	VPX200R3505AM1640	★	5	17	28.5	63	40	24	M16	0.23	8	0.63°	LOGU09
40	VPX200R4004AM1640	★	4	17	28.5	63	40	24	M16	0.26	8	0.54°	LOGU09
40	VPX200R4006AM1640	★	6	17	28.5	63	40	24	M16	0.26	8	0.54°	LOGU09



* For screw-in type arbors, refer to page 126–129.

*1 Number of Teeth

CUTTING CONDITIONS > P130-138

Spare Parts

(mm)

DC	Tool Holder Type	*		
				
		Clamp Screw	Wrench	Anti-seize Lubricant
16	VPX200R16	TPS27F1	TIP07F	MK1KS
18	VPX200R18	TPS27F1	TIP07F	MK1KS
20	VPX200R20	TPS27F1	TIP07F	MK1KS
22	VPX200R22	TPS27F2	TIP07F	MK1KS
25	VPX200R25	TPS27F2	TIP07F	MK1KS
28	VPX200R28	TPS27F2	TIP07F	MK1KS
30	VPX200R30	TPS27F2	TIP07F	MK1KS
32	VPX200R32	TPS27F2	TIP07F	MK1KS
35	VPX200R35	TPS27F2	TIP07F	MK1KS
40	VPX200R40	TPS27F2	TIP07F	MK1KS
50	VPX200R50	TPS27F2	TIP07F	MK1KS

* Clamp Torque (lbf-in) : TPS27F1 = 8.9, TPS27F2 = 8.9

MULTI-FUNCTIONAL MILLING

VPX200 (Metric)

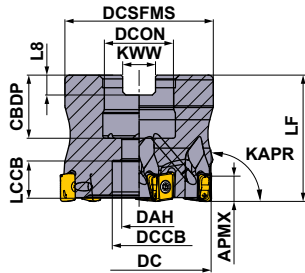

Right hand tool holder only.

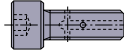

DC	Set Bolt	Geometry
φ32, φ40	HSC08025H	
φ50, φ63	HSC10030H	

Arbor Type

With Coolant Hole

GAMP: -6° T: +5°
GAMF: -25° I: +4°

DC = mm size, DCON = mm size

(mm)

DC	Order Number	Stock R	* No.T	LF	DCON	WT (kg)	APMX	RMPX	Max. Spindle Speed (min ⁻¹)	
										Insert Type
32	VPX200-032A03AR	★	3	35	16	0.11	8	0.71°	25100	LOGU09
32	VPX200-032A05AR	★	5	35	16	0.11	8	0.71°	25100	LOGU09
40	VPX200-040A04AR	★	4	40	16	0.23	8	0.54°	22000	LOGU09
40	VPX200-040A06AR	★	6	40	16	0.22	8	0.54°	22000	LOGU09
50	VPX200-050A05AR	★	5	40	22	0.36	8	0.42°	19200	LOGU09
50	VPX200-050A07AR	★	7	40	22	0.36	8	0.42°	19200	LOGU09
63	VPX200-063A06AR	★	6	40	22	0.66	8	0.32°	16700	LOGU09
63	VPX200-063A09AR	★	9	40	22	0.66	8	0.32°	16700	LOGU09

Note 1) The maximum spindle speeds are set to ensure tool and insert stability.

Note 2) When using the tool at high spindle speeds, ensure that the tool and arbor are correctly balanced.

CUTTING CONDITIONS > P130 - 138

* Number of Teeth



Mounting Dimensions

(mm)

DC	Order Number	DCON	CBDB	DAH	DCCB	LCCB	DCSFMS	KWW	L8
32	VPX200-032A03AR	16	18	9	14	8	30	8.4	5.6
32	VPX200-032A05AR	16	18	9	14	8	30	8.4	5.6
40	VPX200-040A04AR	16	18	9	14	13	37	8.4	5.6
40	VPX200-040A06AR	16	18	9	14	13	37	8.4	5.6
50	VPX200-050A05AR	22	20	11	17	11	47	10.4	6.3
50	VPX200-050A07AR	22	20	11	17	11	47	10.4	6.3
63	VPX200-063A06AR	22	20	11	17	11	60	10.4	6.3
63	VPX200-063A09AR	22	20	11	17	11	60	10.4	6.3

Spare Parts

(mm)

DC	Tool Holder Type			
		Clamp Screw	Wrench	Anti-seize Lubricant
32	VPX200-032	TPS27F2	TIP07F	MK1KS
40	VPX200-040	TPS27F2	TIP07F	MK1KS
50	VPX200-050	TPS27F2	TIP07F	MK1KS
63	VPX200-063	TPS27F2	TIP07F	MK1KS

* Clamp Torque (lbf-in) : TPS27F2 = 8.9

* See Index on page 4 for table icon reference. (●, ★, □)

VPX200

MULTI-FUNCTIONAL MILLING

Inserts

(inch)

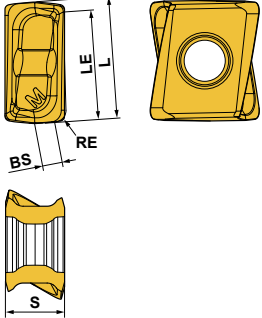
Workpiece Material	P	Steels														Cutting Conditions (Guide) : ● : Stable Cutting ● : General Cutting ✦ : Unstable Cutting Edge Preparation : E : Round F : Sharp Edge	
	M	Stainless Steels															
Shape	K	Cast Irons														L RE LE S BS	Geometry
	N	Non-ferrous Metals															
	S	Heat Resistant Alloys, Titanium Alloys															
H	Hardened Steels																
Order Number	Class	Edge Preparation	Coated						Carbide		L	RE	LE	S	BS	Geometry	
			MC5020	MP6120	MP6130	MP7130	MP9120	MP9130	VP15TF	TF15							
	LOGU0904020PNER-M	G	F	●	●	●	●	●	●			.343	.008	.299	.169	.067	 <p>Right hand insert only.</p>
	LOGU0904040PNER-M	G	F	●	●	●	●	●	●			.343	.016	.299	.169	.063	
	LOGU0904080PNER-M	G	F	●	●	●	●	●	●			.343	.031	.299	.169	.047	
	LOGU0904100PNER-M	G	F	●	●	●	●	●	●			.343	.039	.299	.169	.039	
	LOGU0904120PNER-M	G	F	●	●	●	●	●	●			.343	.047	.299	.169	.035	
	LOGU0904160PNER-M	G	F	●	●	●	●	●	●			.343	.063	.299	.169	.020	
	LOGU0904020PNFR-M	G	F							●		.343	.008	.299	.169	.067	
	LOGU0904040PNFR-M	G	F							●		.343	.016	.299	.169	.063	
	LOGU0904080PNFR-M	G	F							●		.343	.031	.299	.169	.047	
	LOGU0904100PNFR-M	G	F							●		.343	.039	.299	.169	.039	
	LOGU0904120PNFR-M	G	F							●		.343	.047	.299	.169	.035	
	LOGU0904160PNFR-M	G	F							●		.343	.063	.299	.169	.020	

MULTI-FUNCTIONAL MILLING

VPX300 (Inch)

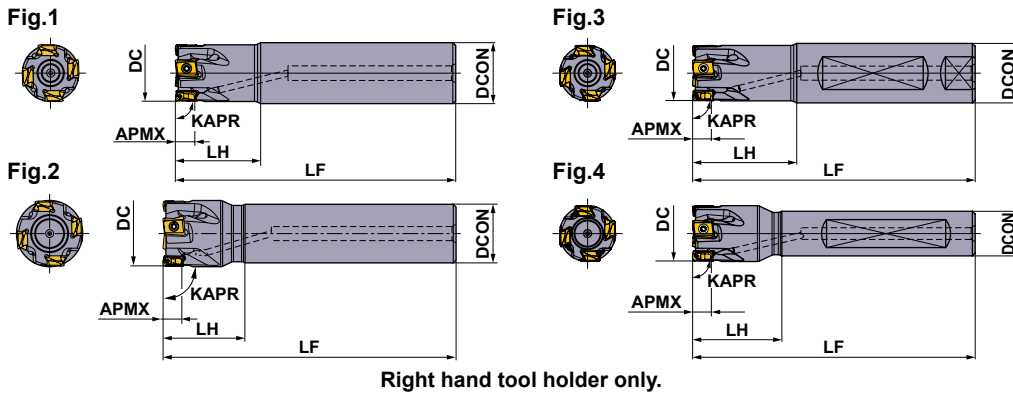

Shank Type

With Coolant Hole

(inch)

DC	Order Number	Stock	* No.T	DCON	LF	LH	APMX	RMPX	Max. Spindle Speed (min ⁻¹)	WT (lbs)	Fig.	Insert Type
		R										LOGU12
1.000	VPX300UR1602FA16S	●	2	1.000	4.750	1.750	.433	2.07°	23900	.8	3	LOGU12
1.000	VPX300UR1602SA16S	●	2	1.000	4.750	1.750	.433	2.07°	23900	.9	1	LOGU12
1.000	VPX300UR1602SA16L	●	2	1.000	8.500	2.500	.433	2.07°	23900	1.7	1	LOGU12
1.125	VPX300UR1802SA16L	●	2	1.000	8.500	1.750	.433	1.73°	22200	1.9	2	LOGU12
1.250	VPX300UR2002FA16S	●	2	1.000	5.125	1.750	.433	1.49°	20700	1.1	4	LOGU12
1.250	VPX300UR2002SA16S	●	2	1.000	5.125	1.750	.433	1.49°	20700	1.1	2	LOGU12
1.250	VPX300UR2003FA16S	●	3	1.000	5.125	1.750	.433	1.49°	20700	1.1	4	LOGU12
1.250	VPX300UR2003SA16S	●	3	1.000	5.125	1.750	.433	1.49°	20700	1.1	2	LOGU12
1.250	VPX300UR2003SA16L	●	3	1.000	9.000	1.750	.433	1.49°	20700	1.9	2	LOGU12
1.250	VPX300UR2002FA20S	●	2	1.250	5.125	2.000	.433	1.49°	20700	1.5	3	LOGU12
1.250	VPX300UR2002SA20S	●	2	1.250	5.125	2.000	.433	1.49°	20700	1.5	1	LOGU12
1.250	VPX300UR2003FA20S	●	3	1.250	5.125	2.000	.433	1.49°	20700	1.5	3	LOGU12
1.250	VPX300UR2003SA20S	●	3	1.250	5.125	2.000	.433	1.49°	20700	1.5	1	LOGU12
1.250	VPX300UR2003SA20L	●	3	1.250	9.000	3.000	.433	1.49°	20700	2.8	1	LOGU12
1.500	VPX300UR2402FA20S	●	2	1.250	5.125	2.000	.433	1.13°	18500	1.7	4	LOGU12
1.500	VPX300UR2402SA20S	●	2	1.250	5.125	2.000	.433	1.13°	18500	1.7	2	LOGU12
1.500	VPX300UR2403FA20S	●	3	1.250	5.125	2.000	.433	1.13°	18500	1.7	4	LOGU12
1.500	VPX300UR2403SA20S	●	3	1.250	5.125	2.000	.433	1.13°	18500	1.7	2	LOGU12
1.500	VPX300UR2403SA20L	●	3	1.250	9.000	2.000	.433	1.13°	18500	3.0	2	LOGU12

Note 1) The maximum spindle speeds are set to ensure tool and insert stability.

Note 2) When using the tool at high spindle speeds, ensure that the tool and arbor are correctly balanced.

* Number of Teeth

CUTTING CONDITIONS > P140-151

VPX SERIES



VPX300 (Inch)

MULTI-FUNCTIONAL MILLING

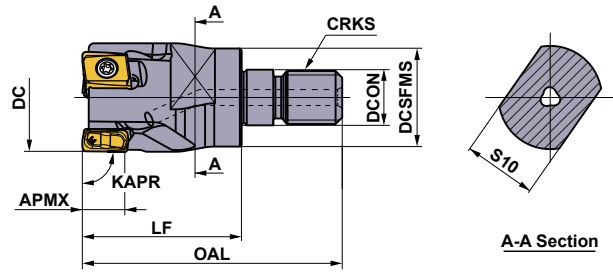
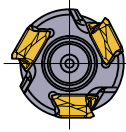

Right hand tool holder only.

Screw-in Type

With Coolant Hole

(inch)

DC	Order Number	Stock R	*1 No.T	DCON	DCSFMS	OAL	LF	S10	CRKS	WT (lbs)	APMX	RMPX	Insert Type
													
1.000	VPX300UR1602AM1235	●	2	.492	.925	2.244	1.378	.748	M12	.2	.433	2.07°	LOGU12
1.125	VPX300UR1802AM1235	●	2	.492	.925	2.244	1.378	.748	M12	.3	.433	1.73°	LOGU12
1.250	VPX300UR2002AM1640	●	2	.669	1.122	2.480	1.575	.945	M16	.4	.433	1.49°	LOGU12
1.250	VPX300UR2003AM1640	●	3	.669	1.122	2.480	1.575	.945	M16	.4	.433	1.49°	LOGU12
1.375	VPX300UR2202AM1640	●	2	.669	1.122	2.480	1.575	.945	M16	.5	.433	1.28°	LOGU12
1.375	VPX300UR2203AM1640	●	3	.669	1.122	2.480	1.575	.945	M16	.5	.433	1.28°	LOGU12
1.500	VPX300UR2403AM1640	●	3	.669	1.122	2.480	1.575	.945	M16	.5	.433	1.13°	LOGU12
1.500	VPX300UR2404AM1640	●	4	.669	1.122	2.480	1.575	.945	M16	.5	.433	1.13°	LOGU12



* For screw-in type arbors, refer to page 126 – 129 .

*1 Number of Teeth

CUTTING CONDITIONS > P140-151

Spare Parts

(inch)

DC	Tool Holder Type	*		
				
		Clamp Screw	Wrench	Anti-seize Lubricant
1.000	VPX300UR16	TPS40F1	TIP15W	MK1KS
1.125	VPX300UR18	TPS40F1	TIP15W	MK1KS
1.250	VPX300UR20	TPS40F1	TIP15W	MK1KS
1.375	VPX300UR22	TPS40F1	TIP15W	MK1KS
1.500	VPX300UR24	TPS40F1	TIP15W	MK1KS

* Clamp Torque (lbf-in) : TPS40F1 = 26.6

MULTI-FUNCTIONAL MILLING

VPX300 (Inch)

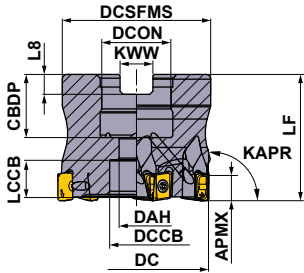

Right hand tool holder only.



DCON	Set Bolt	Geometry
φ.500"	HSCU25011H	
φ.750"	HSCU37513H	
φ.1.000"	HSCU50014H	

Arbor Type

With Coolant Hole

GAMP: -6° T: +5°
GAMF: -22.5° I: +5°

DC=Inch size, DCON=Inch size

(inch)

DC	Order Number	Stock	* No.T	LF	DCON	WT (lbs)	APMX	RMPX	Max. Spindle Speed (min ⁻¹)	
		R								Insert Type
1.500	VPX300UR1.5003SA	●	3	1.750	.500	.240	.433	1.13°	18500	LOGU12
1.500	VPX300UR1.5004SA	●	4	1.750	.500	.240	.433	1.13°	18500	LOGU12
2.000	VPX300UR2.0004AA	●	4	1.750	.750	.400	.433	.78°	15400	LOGU12
2.000	VPX300UR2.0006AA	●	6	1.750	.750	.390	.433	.78°	15400	LOGU12
2.500	VPX300UR2.5006CA	●	6	2.000	1.000	.700	.433	.59°	13400	LOGU12
2.500	VPX300UR2.5008CA	●	8	2.000	1.000	.720	.433	.59°	13400	LOGU12
3.000	VPX300UR3.0007CA	●	7	2.000	1.000	.940	.433	.48°	11900	LOGU12
3.000	VPX300UR3.0010CA	●	10	2.000	1.000	.950	.433	.48°	11900	LOGU12

Note 1) The maximum spindle speeds are set to ensure tool and insert stability.
Note 2) When using the tool at high spindle speeds, ensure that the tool and arbor are correctly balanced.

CUTTING CONDITIONS > P140-151

* Number of Teeth

Mounting Dimensions

(inch)

DC	Order Number	DCON	CBDP	DAH	DCCB	LCCB	DCSFMS	KWW	L8
1.500	VPX300UR1.5003SA	.500	.63	.276	.433	.663	1.438	.25	.156
1.500	VPX300UR1.5004SA	.500	.63	.276	.433	.663	1.438	.25	.156
2.000	VPX300UR2.0004AA	.750	.748	.413	.63	.545	1.75	.313	.187
2.000	VPX300UR2.0006AA	.750	.748	.413	.63	.545	1.75	.313	.187
2.500	VPX300UR2.5006CA	1.000	.945	.539	.787	.677	2.188	.375	.219
2.500	VPX300UR2.5008CA	1.000	.945	.539	.787	.677	2.188	.375	.219
3.000	VPX300UR3.0007CA	1.000	.945	.539	.787	.677	2.188	.375	.219
3.000	VPX300UR3.0010CA	1.000	.945	.539	.787	.677	2.188	.375	.219

Spare Parts

(inch)

DC	Tool Holder Type			
		Clamp Screw	Wrench	Anti-seize Lubricant
1.500	VPX300UR1.500	TPS40F1	TIP15W	MK1KS
2.000	VPX300UR2.000	TPS40F1	TIP15W	MK1KS
2.500	VPX300UR2.500	TPS40F1	TIP15W	MK1KS
3.000	VPX300UR3.000	TPS40F1	TIP15W	MK1KS

* Clamp Torque (lbf-in) : TPS40F1 = 26.6

* See Index on page 4 for table icon reference. (●, ★, □)

VPX300 (Metric)

MULTI-FUNCTIONAL MILLING

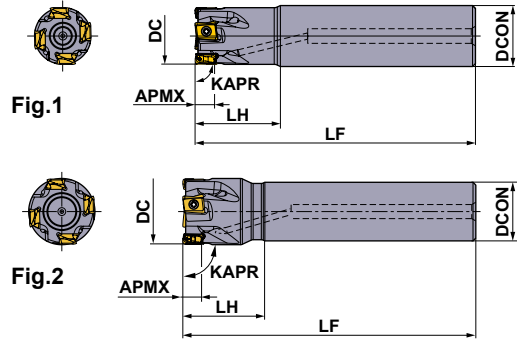

Right hand tool holder only.

Shank Type

With Coolant Hole

(mm)

DC	Order Number	Stock	* No.T	DCON	LF	LH	APMX	RMPX	Max. Spindle Speed (min ⁻¹)	WT (kg)	Fig.	Insert Type
												R
25	VPX300R2502SA25S	★	2	25	115	35	11	2.13°	24100	0.38	1	LOGU12
25	VPX300R2502SA25L	★	2	25	170	70	11	2.13°	24100	0.56	1	LOGU12
28	VPX300R2802SA25S	★	2	25	115	35	11	1.77°	22500	0.40	2	LOGU12
28	VPX300R2802SA25L	★	2	25	170	35	11	1.77°	22500	0.60	2	LOGU12
30	VPX300R3002SA25S	★	2	25	125	35	11	1.61°	21500	0.45	2	LOGU12
30	VPX300R3003SA25S	★	3	25	125	35	11	1.61°	21500	0.44	2	LOGU12
32	VPX300R3202SA32S	★	2	32	125	45	11	1.47°	20600	0.69	1	LOGU12
32	VPX300R3203SA32S	★	3	32	125	45	11	1.47°	20600	0.68	1	LOGU12
32	VPX300R3203SA32L	★	3	32	190	90	11	1.47°	20600	1.04	1	LOGU12
35	VPX300R3503SA32L	★	3	32	190	45	11	1.28°	19500	1.10	2	LOGU12
40	VPX300R4003SA32S	★	3	32	125	45	11	1.06°	17900	0.76	2	LOGU12
40	VPX300R4004SA32S	★	4	32	125	45	11	1.06°	17900	0.76	2	LOGU12
50	VPX300R5004SA32S	★	4	32	125	45	11	0.79°	15500	0.89	2	LOGU12
50	VPX300R5006SA32S	★	6	32	125	45	11	0.79°	15500	0.88	2	LOGU12

Note 1) The maximum spindle speeds are set to ensure tool and insert stability.

Note 2) When using the tool at high spindle speeds, ensure that the tool and arbor are correctly balanced.

* Number of Teeth

CUTTING CONDITIONS > P140-151

MULTI-FUNCTIONAL MILLING

VPX300 (Metric)

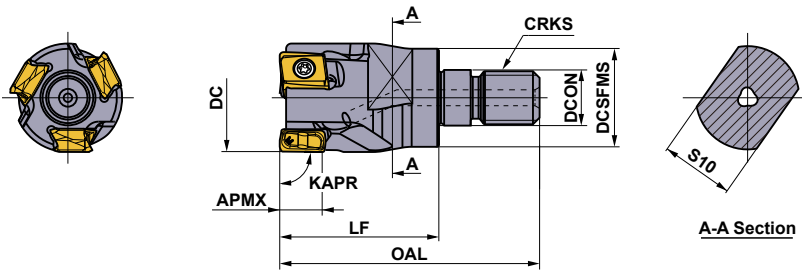

Right hand tool holder only.

Screw-in Type

With Coolant Hole

(mm)

DC	Order Number	Stock	*1 No.T	DCON	DCSFMS	OAL	LF	S10	CRKS	WT (kg)	APMX	RMPX	 Insert Type
25	VPX300R2502AM1235	★	2	12.5	23.5	57	35	19	M12	0.10	11	2.13°	LOGU12
28	VPX300R2802AM1235	★	2	12.5	23.5	57	35	19	M12	0.12	11	1.77°	LOGU12
32	VPX300R3202AM1640	★	2	17	28.5	63	40	24	M16	0.20	11	1.47°	LOGU12
32	VPX300R3203AM1640	★	3	17	28.5	63	40	24	M16	0.19	11	1.47°	LOGU12
35	VPX300R3502AM1640	★	2	17	28.5	63	40	24	M16	0.22	11	1.28°	LOGU12
35	VPX300R3503AM1640	★	3	17	28.5	63	40	24	M16	0.22	11	1.28°	LOGU12
40	VPX300R4003AM1640	★	3	17	28.5	63	40	24	M16	0.26	11	1.06°	LOGU12
40	VPX300R4004AM1640	★	4	17	28.5	63	40	24	M16	0.26	11	1.06°	LOGU12



* For screw-in type arbors, refer to page 126- 129.

CUTTING CONDITIONS > P140-151

*1 Number of Teeth

Spare Parts

(mm)

DC	Tool Holder Type	*		
		 Clamp Screw	 Wrench	 Anti-seize Lubricant
25	VPX300R25	TPS40F1	TIP15W	MK1KS
28	VPX300R28	TPS40F1	TIP15W	MK1KS
30	VPX300R30	TPS40F1	TIP15W	MK1KS
32	VPX300R32	TPS40F1	TIP15W	MK1KS
35	VPX300R35	TPS40F1	TIP15W	MK1KS
40	VPX300R40	TPS40F1	TIP15W	MK1KS
50	VPX300R50	TPS40F1	TIP15W	MK1KS

* Clamp Torque (lbf-in) : TPS40F1 = 26.6

VPX SERIES



VPX300 For Metric Arbors (Metric)

MULTI-FUNCTIONAL MILLING

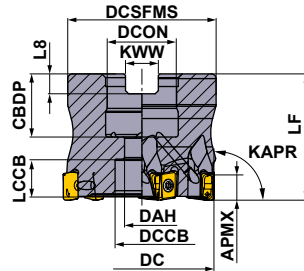

DC	Set Bolt	Geometry
φ40	HSC08025H	
φ50, φ63	HSC10030H	
φ80	HSC12035H	

Arbor Type

With Coolant Hole

GAMP: -6° T: +5°

GAMF: -22.5° I: +5°

DC=mm size, DCON=mm size, DCON=Inch size

Right hand tool holder only.

DC	Order Number	Stock	No.T *	LF	DCON	WT (kg)	APMX	RMPX	Max. Spindle Speed (min ⁻¹)		Insert Type
40	VPX300-040A03AR	★	3	40	16	0.21	11	1.06°	17900		LOGU12
40	VPX300-040A04AR	★	4	40	16	0.21	11	1.06°	17900		LOGU12
50	VPX300-050A04AR	★	4	40	22	0.34	11	0.79°	15500		LOGU12
50	VPX300-050A06AR	★	6	40	22	0.33	11	0.79°	15500		LOGU12
63	VPX300-063A06AR	★	6	40	22	0.61	11	0.60°	13400		LOGU12
63	VPX300-063A08AR	★	8	40	22	0.62	11	0.60°	13400		LOGU12
80	VPX300R08007CA	★	7	50	25.4[1.0"]	1.00	11	0.45°	11500		LOGU12
80	VPX300R08010CA	★	10	50	25.4[1.0"]	1.00	11	0.45°	11500		LOGU12
80	VPX300-080A07AR	★	7	50	27	0.99	11	0.45°	11500		LOGU12
80	VPX300-080A10AR	★	10	50	27	0.99	11	0.45°	11500		LOGU12

Note 1) The maximum spindle speeds are set to ensure tool and insert stability.

Note 2) When using the tool at high spindle speeds, ensure that the tool and arbor are correctly balanced.

* Number of Teeth

CUTTING CONDITIONS > P140-151

Mounting Dimensions

DC	Order Number	DCON	CBDP	DAH	DCCB	LCCB	DCSFMS	KWW	L8
40	VPX300-040A03AR	16	18	9	14	12.4	37	8.4	5.6
40	VPX300-040A04AR	16	18	9	14	12.4	37	8.4	5.6
50	VPX300-050A04AR	22	20	11	17	10.4	47	10.4	6.3
50	VPX300-050A06AR	22	20	11	17	10.4	47	10.4	6.3
63	VPX300-063A06AR	22	20	11	17	10.4	60	10.4	6.3
63	VPX300-063A08AR	22	20	11	17	10.4	60	10.4	6.3
80	VPX300R08007CA	25.4[1.0"]	26	13	20	13.4	56	9.5	6
80	VPX300R08010CA	25.4[1.0"]	26	13	20	13.4	56	9.5	6
80	VPX300-080A07AR	27	23	13	20	13.4	56	12.4	7
80	VPX300-080A10AR	27	23	13	20	13.4	56	12.4	7

Spare Parts

DC	Tool Holder Type	*		
		Clamp Screw	Wrench	Anti-seize Lubricant
40	VPX300-040	TPS40F1	TIP15W	MK1KS
50	VPX300-050	TPS40F1	TIP15W	MK1KS
63	VPX300-063	TPS40F1	TIP15W	MK1KS
80	VPX300R080	TPS40F1	TIP15W	MK1KS
80	VPX300-080	TPS40F1	TIP15W	MK1KS

* Clamp Torque (lbf-in) : TPS40F1 = 26.6

* See Index on page 4 for table icon reference. (●, ★, □)

MULTI-FUNCTIONAL MILLING

Inserts

(inch)

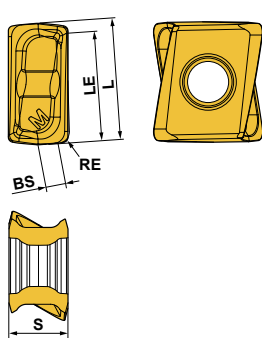
Workpiece Material	P	Steels																	
	M	Stainless Steels																	
	K	Cast Irons																	
	N	Non-ferrous Metals																	
S	Heat Resistant Alloys, Titanium Alloys																		
	H	Hardened Steels																	
Shape	Order Number	Class	Edge Preparation	Coated						Carbide		L	RE	LE	S	BS	Geometry		
				MC5020	MP6120	MP6130	MP7130	MP9120	MP9130	VP15TF	TF15								
	LOGU1207020PNER-M	G	E	●	●	●	●	●	●	●		.488	.008	.445	.276	.118			
	LOGU1207040PNER-M	G	E	●	●	●	●	●	●	●		.488	.016	.445	.276	.110			
	LOGU1207080PNER-M	G	E	●	●	●	●	●	●	●		.488	.031	.445	.276	.094			
	LOGU1207100PNER-M	G	E	●	●	●	●	●	●	●		.488	.039	.445	.276	.091			
	LOGU1207120PNER-M	G	E	●	●	●	●	●	●	●		.488	.047	.445	.276	.083			
	LOGU1207160PNER-M	G	E	●	●	●	●	●	●	●		.488	.063	.445	.276	.067			
	LOGU1207200PNER-M	G	E	●	●	●	●	●	●	●		.488	.079	.445	.276	.055			
	LOGU1207240PNER-M	G	E	●	●	●	●	●	●	●		.488	.094	.445	.276	.039			
	LOGU1207300PNER-M	G	E	●	●	●	●	●	●	●		.488	.118	.445	.276	.020			
	LOGU1207320PNER-M	G	E	●	●	●	●	●	●	●		.488	.126	.445	.276	.012			
	LOGU1207020PNFR-M	G	F							●		.488	.008	.445	.276	.118			
	LOGU1207040PNFR-M	G	F							●		.488	.016	.445	.276	.110			
	LOGU1207080PNFR-M	G	F							●		.488	.031	.445	.276	.094			
	LOGU1207100PNFR-M	G	F							●		.488	.039	.445	.276	.091			
	LOGU1207120PNFR-M	G	F							●		.488	.047	.445	.276	.083			
	LOGU1207160PNFR-M	G	F							●		.488	.063	.445	.276	.067			
	LOGU1207200PNFR-M	G	F							●		.488	.079	.445	.276	.055			
	LOGU1207240PNFR-M	G	F							●		.488	.094	.445	.276	.039			
	LOGU1207300PNFR-M	G	F							●		.488	.118	.445	.276	.020			
	LOGU1207320PNFR-M	G	F							●		.488	.126	.445	.276	.012			

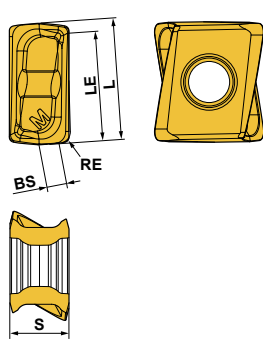

Right hand insert only.

* See Index on page 4 for table icon reference. (●, ★, □)

SCREW-IN HOLDERS STRAIGHT SHANK TYPE

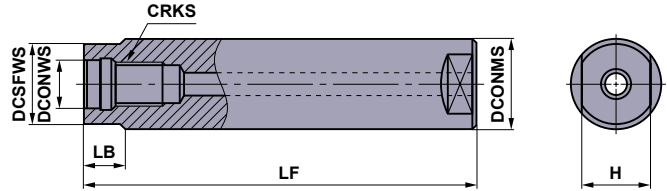

(Inch)

Steel Shank Type

(inch)

CRKS	Order Number	Stock	DCONMS	LF	DCONWS	DCSFWS	LB	H	WT (lbs)
M8	SCU10M08S100S	●	.625	3.937	.335	.571	.394	.394	.2
M8	SCU10M08S200L	●	.625	7.874	.335	.571	.394	.394	.7
M10	SCU12M10S120S	●	.750	4.724	.413	.728	.394	.551	.4
M10	SCU12M10S220L	●	.750	8.661	.413	.728	.394	.551	.9
M12	SCU16M12S125S	●	1.000	4.921	.492	.925	.394	.748	.9
M12	SCU16M12S245L	●	1.000	9.646	.492	.925	.394	.748	2.0
M16	SCU20M16S140S	●	1.250	5.512	.669	1.122	.591	.945	1.8
M16	SCU20M16S280L	●	1.250	11.024	.669	1.122	.591	.945	3.5

(Metric)

(mm)

CRKS	Order Number	Stock	DCONMS	LF	DCONWS	DCSFWS	LB	H	WT (kg)
M8	SC16M08S100S	★	16	100	8.5	14.5	10	10	0.1
M8	SC16M08S200L	★	16	200	8.5	14.5	10	10	0.3
M10	SC20M10S120S	★	20	120	10.5	18.5	10	14	0.3
M10	SC20M10S220L	★	20	220	10.5	18.5	10	14	0.5
M12	SC25M12S125S	★	25	125	12.5	23.5	10	19	0.4
M12	SC25M12S245L	★	25	245	12.5	23.5	10	19	0.8
M16	SC32M16S140S	★	32	140	17	28.5	15	24	0.8
M16	SC32M16S280L	★	32	280	17	28.5	15	24	1.6

SCREW-IN HOLDERS STRAIGHT SHANK TYPE

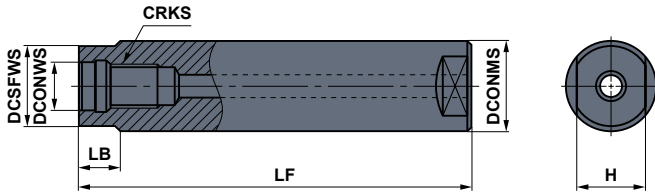

(Inch)

Carbide Shank Type

(inch)

CRKS	Order Number	Stock	DCONMS	LF	DCONWS	DCSFWS	LB	H	WT (lbs)
M8	SCU10M08S100SW	●	.625	3.937	.335	.571	.394	.394	.4
M8	SCU10M08S200LW	●	.625	7.874	.335	.571	.394	.394	1.1
M10	SCU12M10S120SW	●	.750	4.724	.413	.728	.394	.551	.9
M10	SCU12M10S220LW	●	.750	8.661	.413	.728	.394	.551	1.8
M12	SCU16M12S125SW	●	1.000	4.921	.492	.925	.394	.748	1.8
M12	SCU16M12S245LW	●	1.000	9.646	.492	.925	.394	.748	3.5
M16	SCU20M16S140SW	●	1.250	5.512	.669	1.122	.591	.945	3.1
M16	SCU20M16S280LW	●	1.250	11.024	1.250	1.122	.591	.945	6.4

(Metric)

(mm)

CRKS	Order Number	Stock	DCONMS	LF	DCONWS	DCSFWS	LB	H	WT (kg)
M8	SC16M08S100SW	★	16	100	8.5	14.5	10	10	0.2
M8	SC16M08S200LW	★	16	200	8.5	14.5	10	10	0.5
M10	SC20M10S120SW	★	20	120	10.5	18.5	10	14	0.5
M10	SC20M10S220LW	★	20	220	10.5	18.5	10	14	0.9
M12	SC25M12S125SW	★	25	125	12.5	23.5	10	19	0.8
M12	SC25M12S245LW	★	25	245	12.5	23.5	10	19	1.5
M16	SC32M16S140SW	★	32	140	17	28.5	15	24	1.4
M16	SC32M16S280LW	★	32	280	17	28.5	15	24	2.8

SCREW-IN HOLDERS

■ HSK63A Shank Arbor

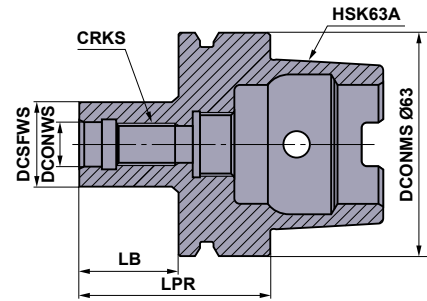

(Metric)

CRKS	Order Number	Stock	DCONWS	DCSFWS	LPR	LB	WT (kg)
M8	SC16M08S22-HSK63A	★	8.5	14.5	48	22	0.7
M10	SC20M10S24-HSK63A	★	10.5	18.5	50	24	0.7
M12	SC25M12S27-HSK63A	★	12.5	23.5	53	27	0.7
M16	SC32M16S28-HSK63A	★	17	28.5	54	28	0.8

■ BT30 Shank Arbor

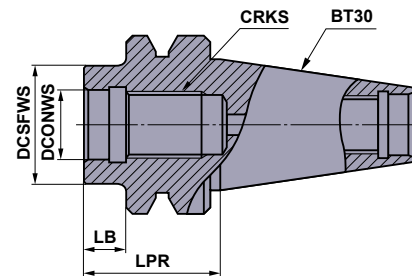

(Metric)

CRKS	Order Number	Stock	DCONWS	DCSFWS	LPR	LB	WT (kg)
M8	SC16M08S10-BT30	★	8.5	14.5	32	10	0.4
M10	SC20M10S10-BT30	★	10.5	18.5	32	10	0.4
M12	SC25M12S10-BT30	★	12.5	23.5	32	10	0.4
M16	SC32M16S10-BT30	★	17	28.5	32	10	0.4

■ BT40 Shank Arbor

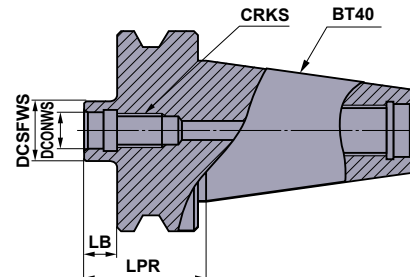

(Metric)

CRKS	Order Number	Stock	DCONWS	DCSFWS	LPR	LB	WT (kg)
M8	SC16M08S10-BT40	★	8.5	14.5	37	10	1
M10	SC20M10S10-BT40	★	10.5	18.5	37	10	1
M12	SC25M12S10-BT40	★	12.5	23.5	37	10	1
M16	SC32M16S10-BT40	★	17	28.5	37	10	1

How to Install the Screw-in Head

- ① Thoroughly clean the clamp section of the head and the arbor with an air blower or brush before installation.
- ② Tighten the head at the recommended torque and ensure that there is no gap between the head and arbor.

Screw Size	Recommended Torque (lbf-ft)	Wrench Size (inch)
M8	17.0	.394
M10	33.9	.551
M12	59.0	.748
M16	66.4	.945



- Cutting tools become extremely hot during cutting. Never touch them with bare hands after operation as this may produce risk of injuries or burns.
- Do not handle the cutting tools with bare hands as this may cause injuries.

VPX200

Recommended Cutting Conditions

Dry Cutting Cutting Speed

(inch)

Workpiece Material	Properties	Cutting Conditions	Insert		Cutting Width ae				
			Grade	Chip Breaker	≤.25DC	.25-.5DC	.5-.75DC	DC(Slot)	
					Cutting Speed vc (SFM)				
P	Mild Steels	≤180HB	● ●	MP6120	M	755 (590-885)	720 (560-850)	590 (460-690)	590 (460-690)
			● ●	VP15TF	M	755 (590-885)	720 (560-850)	590 (460-690)	590 (460-690)
			✱	MP6130	M	655 (490-785)	620 (460-755)	490 (360-590)	490 (360-590)
	Carbon Steels Alloy Steels Alloy Tool Steels	180-350HB ≤350HB (Annealing)	● ●	MP6120	M	590 (460-690)	560 (425-655)	460 (360-525)	460 (360-525)
			● ●	VP15TF	M	590 (460-690)	560 (425-655)	460 (360-525)	460 (360-525)
			✱	MP6130	M	490 (360-590)	460 (330-560)	360 (260-425)	360 (260-425)
	Pre-hardened Steels	35-45HRC	● ●	MP6120	M	395 (295-460)	360 (260-425)	330 (230-395)	330 (230-395)
			● ●	VP15TF	M	395 (295-460)	360 (260-425)	330 (230-395)	330 (230-395)
			✱	MP6130	M	330 (260-395)	295 (230-360)	260 (195-330)	260 (195-330)
M	Austenitic Stainless Steels	≤200HB	● ● ✱	MP7130	M	590 (460-690)	560 (425-655)	460 (360-525)	460 (360-525)
			● ●	VP15TF	M	590 (460-690)	560 (425-655)	460 (360-525)	460 (360-525)
		>200HB	● ● ✱	MP7130	M	490 (360-590)	460 (330-525)	360 (260-425)	360 (260-425)
			● ●	VP15TF	M	490 (360-590)	460 (330-525)	360 (260-425)	360 (260-425)
	Duplex Stainless Steels	≤280HB	● ● ✱	MP7130	M	460 (360-560)	425 (295-490)	330 (230-395)	330 (230-395)
			● ●	VP15TF	M	460 (360-560)	425 (295-490)	330 (230-395)	330 (230-395)
	Ferritic and Martensitic Stainless Steels	-	● ● ✱	MP7130	M	590 (460-690)	560 (425-655)	460 (360-525)	460 (360-525)
			● ●	VP15TF	M	590 (460-690)	560 (425-655)	460 (360-525)	460 (360-525)
	Precipitation Hardening Stainless Steels	<450HB	● ● ✱	MP7130	M	425 (330-525)	395 (260-460)	295 (195-360)	295 (195-360)
			● ●	VP15TF	M	425 (330-525)	395 (260-460)	295 (195-360)	295 (195-360)
	K	Tensile Strength ≤350MPa	● ●	MC5020	M	820 (655-985)	785 (620-950)	690 (525-850)	690 (525-850)
			● ● ✱	VP15TF	M	655 (490-820)	620 (460-785)	525 (360-690)	525 (360-690)
Ductile Cast Irons		Tensile Strength ≤800MPa	● ●	MC5020	M	590 (490-655)	560 (460-620)	490 (395-560)	490 (395-560)
			● ● ✱	VP15TF	M	425 (330-490)	395 (295-460)	330 (260-395)	330 (260-395)
N	Aluminum Alloys	Si<5%	● ● ✱	TF15	M	1970 (1310-3280)	1970 (1310-3280)	1970 (1310-3280)	1970 (1310-3280)
H	Hardened Steels	40-55HRC	● ● ✱	VP15TF	M	295 (230-330)	280 (195-330)	230 (165-260)	230 (165-260)

- Note 1) These cutting conditions should be referenced for standard shank types (last letter in designation is S) and arbor shank types. If there is chatter, insert chipping, etc. during machining, alter conditions accordingly.
- Note 2) Chattering vibration is more likely under the following circumstances. Use a cut and feed per tooth that are at minimum recommended conditions or below.
- When tool overhang is long (using a long shank, screw-in type, etc.)
 - Rigidity of machine, workpiece material or attachment of workpiece material is low
 - Corner radius during pocket milling
- Note 3) A type with fewer teeth is recommended when the depth of cut in the radius direction (ae) is .5 DC or more.
- Note 4) Wet cutting is recommended, when focusing on the surface finish. (Tool life is shorter than for dry cutting.)
- Note 5) When using under higher than recommended cutting conditions, or for long periods of time, the clamp screw may become fatigued and break during machining. Please change out the clamp screw periodically.

Recommended Cutting Conditions

Depth of Cut / Feed per Tooth

(inch)

Cutting Conditions (Guide) :

● : Stable Cutting ● : General Cutting ✖ : Unstable Cutting

Workpiece Material	Properties	Cutting Width ae	Cutting Conditions	Cutter Diameter DC						
				ø.625-ø.750(ø16mm-ø18mm)		ø.875-ø1.000(ø20mm-ø25mm)		ø1.125-ø2.500(ø28mm-ø63mm)		
				Depth of Cut ap	Feed per Tooth fz (IPT)	Depth of Cut ap	Feed per Tooth fz (IPT)	Depth of Cut ap	Feed per Tooth fz (IPT)	
P	Mild Steels	≤.25DC	● ● ✖	≤.236	.004-.006	≤.315	.004-.008	≤.315	.004-.010	
		.25-.5DC	● ● ✖	≤.197	.003-.005	≤.315	.004-.006	≤.315	.004-.008	
		.5-.75DC	● ● ✖	≤.157	.003-.005	≤.236	.003-.005	≤.236	.004-.006	
		DC(Slot)	● ● ✖	≤.079	.002-.004	≤.157	.002-.004	≤.157	.003-.005	
	Carbon Steels Alloy Steels Alloy Tool Steels	180-280HB	≤.25DC	● ● ✖	≤.236	.004-.006	≤.315	.004-.008	≤.315	.004-.010
			.25-.5DC	● ● ✖	≤.197	.003-.005	≤.315	.004-.006	≤.315	.004-.008
			.5-.75DC	● ● ✖	≤.157	.003-.005	≤.236	.003-.005	≤.236	.004-.006
			DC(Slot)	● ● ✖	≤.079	.002-.004	≤.157	.002-.004	≤.157	.003-.005
	Carbon Steels Alloy Steels Alloy Tool Steels	280-350HB ≤350HB (Annealing)	≤.25DC	● ● ✖	≤.236	.004-.006	≤.315	.004-.006	≤.315	.004-.008
			.25-.5DC	● ● ✖	≤.197	.003-.005	≤.315	.003-.005	≤.315	.004-.006
			.5-.75DC	● ● ✖	≤.157	.003-.005	≤.236	.002-.004	≤.236	.003-.005
			DC(Slot)	● ● ✖	≤.079	.002-.004	≤.157	.002-.004	≤.157	.002-.004
Pre-hardened Steels	35-45HRC	≤.25DC	● ● ✖	≤.236	.004-.006	≤.315	.004-.006	≤.315	.004-.008	
		.25-.5DC	● ● ✖	≤.197	.003-.005	≤.315	.003-.005	≤.315	.004-.006	
		.5-.75DC	● ● ✖	≤.157	.003-.005	≤.236	.002-.004	≤.236	.003-.005	
		DC(Slot)	● ● ✖	≤.079	.002-.004	≤.157	.002-.004	≤.157	.002-.004	
M	Austenitic Stainless Steels	≤.25DC	● ● ✖	≤.236	.004-.006	≤.315	.004-.008	≤.315	.004-.008	
		.25-.5DC	● ● ✖	≤.197	.003-.005	≤.315	.003-.006	≤.315	.003-.006	
		.5-.75DC	● ● ✖	≤.157	.002-.004	≤.236	.003-.005	≤.236	.003-.005	
		DC(Slot)	● ● ✖	≤.079	.002-.004	≤.157	.002-.004	≤.157	.002-.004	
	Duplex Stainless Steels	≤280HB	≤.25DC	● ● ✖	≤.236	.004-.006	≤.315	.004-.008	≤.315	.004-.008
			.25-.5DC	● ● ✖	≤.197	.003-.005	≤.315	.003-.006	≤.315	.003-.006
			.5-.75DC	● ● ✖	≤.157	.002-.004	≤.236	.003-.005	≤.236	.003-.005
			DC(Slot)	● ● ✖	≤.079	.002-.004	≤.157	.002-.004	≤.157	.002-.004
	Ferritic and Martensitic Stainless Steels	-	≤.25DC	● ● ✖	≤.236	.004-.006	≤.315	.004-.008	≤.315	.004-.008
			.25-.5DC	● ● ✖	≤.197	.003-.005	≤.315	.003-.006	≤.315	.003-.006
			.5-.75DC	● ● ✖	≤.157	.002-.004	≤.236	.003-.005	≤.236	.003-.005
			DC(Slot)	● ● ✖	≤.079	.002-.004	≤.157	.002-.004	≤.157	.002-.004
Precipitation Hardening Stainless Steels	<450HB	≤.25DC	● ● ✖	≤.236	.004-.006	≤.315	.004-.006	≤.315	.004-.006	
		.25-.5DC	● ● ✖	≤.197	.003-.005	≤.315	.003-.005	≤.315	.003-.005	
		.5-.75DC	● ● ✖	≤.157	.002-.004	≤.236	.002-.004	≤.236	.002-.004	
		DC(Slot)	● ● ✖	≤.079	.002-.004	≤.157	.002-.004	≤.157	.002-.004	

Milling Tool
Inserts

Note 1) These cutting conditions should be referenced for standard shank types (last letter in designation is S) and arbor shank types. If there is chatter, insert chipping, etc. during machining, alter conditions accordingly.

Note 2) Chattering vibration is more likely under the following circumstances. Use a cut and feed per tooth that are at minimum recommended conditions or below.

- When tool overhang is long (using a long shank, screw-in type, etc.)
- Rigidity of machine, workpiece material or attachment of workpiece material is low
- Corner radius during pocket milling

Note 3) A type with fewer teeth is recommended when the depth of cut in the radius direction (ae) is .5 DC or more.

Note 4) Wet cutting is recommended, when focusing on the surface finish. (Tool life is shorter than for dry cutting.)

Note 5) When using under higher than recommended cutting conditions, or for long periods of time, the clamp screw may become fatigued and break during machining. Please change out the clamp screw periodically.

* See Index on page 4 for table icon reference. (●, ★, □)

VPX200 Recommended Cutting Conditions

■ Dry Cutting Depth of Cut / Feed per Tooth

(inch)

Workpiece Material	Properties	Cutting Width ae	Cutting Conditions	Cutter Diameter DC							
				ø.625-ø.750(ø16mm-ø18mm)		ø.875-ø1.000(ø20mm-ø25mm)		ø1.125-ø2.500(ø28mm-ø63mm)			
				Depth of Cut ap	Feed per Tooth fz (IPT)	Depth of Cut ap	Feed per Tooth fz (IPT)	Depth of Cut ap	Feed per Tooth fz (IPT)		
K	Gray Cast Irons Tensile Strength ≤350MPa	≤.25DC	● ●	≤.236	.004-.006	≤.315	.004-.008	≤.315	.004-.010		
			★	≤.236	.003-.005	≤.315	.003-.006	≤.315	.004-.008		
		.25-.5DC	● ●	≤.197	.003-.005	≤.315	.003-.006	≤.315	.004-.008		
			★	≤.197	.002-.004	≤.315	.003-.005	≤.315	.004-.006		
		.5-.75DC	● ●	≤.157	.003-.005	≤.236	.003-.005	≤.236	.004-.006		
			★	≤.157	.003-.005	≤.236	.002-.004	≤.236	.003-.005		
		DC(Slot)	● ●	≤.079	.002-.004	≤.157	.002-.004	≤.157	.003-.006		
			★	≤.079	.002-.003	≤.157	.002-.003	≤.157	.003-.004		
		Ductile Cast Irons Tensile Strength ≤800MPa	≤.25DC	● ●	≤.236	.004-.006	≤.315	.004-.008	≤.315	.004-.008	
				★	≤.236	.003-.005	≤.315	.004-.006	≤.315	.004-.006	
.25-.5DC	● ●		≤.197	.003-.005	≤.315	.004-.006	≤.315	.004-.006			
	★		≤.197	.002-.004	≤.315	.003-.005	≤.315	.003-.005			
.5-.75DC	● ●		≤.157	.003-.005	≤.236	.003-.005	≤.236	.003-.005			
	★		≤.157	.003-.005	≤.236	.002-.004	≤.236	.002-.004			
DC(Slot)	● ●		≤.079	.002-.004	≤.157	.002-.004	≤.157	.002-.004			
	★		≤.079	.002-.003	≤.157	.002-.003	≤.157	.002-.003			
N	Aluminum Alloys Si < 5%		≤.25DC	● ●	≤.236	.004-.008	≤.315	.004-.010	≤.315	.004-.010	
				★	≤.236	.004-.006	≤.315	.004-.008	≤.315	.004-.008	
		.25-.5DC	● ●	≤.197	.004-.006	≤.315	.004-.008	≤.315	.004-.008		
			★	≤.197	.003-.005	≤.315	.004-.006	≤.315	.004-.006		
		.5-.75DC	● ●	≤.157	.003-.005	≤.236	.002-.006	≤.236	.003-.006		
			★	≤.157	.002-.004	≤.236	.002-.006	≤.236	.003-.006		
		DC(Slot)	● ●	≤.079	.002-.004	≤.157	.002-.006	≤.157	.003-.006		
			★	≤.079	.002-.003	≤.157	.002-.005	≤.157	.003-.005		
		H	Hardened Steels 40-55HRC	≤.25DC	● ●	≤.157	.003-.006	≤.157	.003-.006	≤.157	.003-.006
					★	≤.157	.003-.005	≤.157	.003-.005	≤.157	.003-.005
.25-.5DC	● ●			≤.118	.003-.005	≤.118	.003-.005	≤.118	.003-.005		
	★			≤.118	.002-.004	≤.118	.003-.004	≤.118	.002-.004		
.5-.75DC	● ●			≤.079	.002-.004	≤.079	.003-.004	≤.079	.002-.004		
	★			≤.079	.002-.003	≤.079	.002-.003	≤.079	.002-.003		
DC(Slot)	● ●			≤.039	.002-.004	≤.039	.002-.004	≤.039	.002-.004		
	★			≤.039	.002-.003	≤.039	.002-.003	≤.039	.002-.003		

- Note 1) These cutting conditions should be referenced for standard shank types (last letter in designation is S) and arbor shank types. If there is chatter, insert chipping, etc. during machining, alter conditions accordingly.
- Note 2) Chattering vibration is more likely under the following circumstances. Use a cut and feed per tooth that are at minimum recommended conditions or below.
- When tool overhang is long (using a long shank, screw-in type, etc.)
 - Rigidity of machine, workpiece material or attachment of workpiece material is low
 - Corner radius during pocket milling
- Note 3) A type with fewer teeth is recommended when the depth of cut in the radius direction (ae) is .5 DC or more.
- Note 4) Wet cutting is recommended, when focusing on the surface finish. (Tool life is shorter than for dry cutting.)
- Note 5) When using under higher than recommended cutting conditions, or for long periods of time, the clamp screw may become fatigued and break during machining. Please change out the clamp screw periodically.

Wet Cutting ■
Cutting Speed

(inch)

Workpiece Material	Properties	Cutting Conditions	Insert		Cutting Width ae					
			Grade	Chip Breaker	≤.25DC	.25-.5DC	.5-.75DC	DC(Slot)		
					Cutting Speed vc (SFM)					
P	Mild Steels	≤180HB	● ●	MP6120	M	460 (330-620)	425 (295-590)	330 (230-395)	330 (230-395)	
			● ●	VP15TF	M	460 (330-620)	425 (295-590)	330 (230-395)	330 (230-395)	
			✦	MP6130	M	460 (330-620)	425 (295-590)	330 (230-395)	330 (230-395)	
	Carbon Steels Alloy Steels Alloy Tool Steels	180-350HB ≤350HB (Annealing)	● ●	MP6120	M	395 (295-460)	360 (260-425)	330 (230-395)	330 (230-395)	
			● ●	VP15TF	M	395 (295-460)	360 (260-425)	330 (230-395)	330 (230-395)	
			✦	MP6130	M	395 (295-460)	360 (260-425)	330 (230-395)	330 (230-395)	
	Pre-hardened Steels	35-45HRC	● ●	MP6120	M	330 (260-395)	295 (230-360)	260 (195-330)	260 (195-330)	
			● ●	VP15TF	M	330 (260-395)	295 (230-360)	260 (195-330)	260 (195-330)	
			✦	MP6130	M	330 (260-395)	295 (230-360)	260 (195-330)	260 (195-330)	
M	Austenitic Stainless Steels	≤200HB	● ● ✦	MP7130	M	395 (330-490)	360 (295-460)	295 (230-395)	295 (230-395)	
			● ●	VP15TF	M	395 (330-490)	360 (295-460)	295 (230-395)	295 (230-395)	
		>200HB	● ● ✦	MP7130	M	330 (260-425)	295 (230-360)	230 (165-330)	230 (165-330)	
			● ●	VP15TF	M	330 (260-425)	295 (230-360)	230 (165-330)	230 (165-330)	
	Duplex Stainless Steels	≤280HB	● ● ✦	MP7130	M	330 (260-425)	295 (230-395)	230 (165-330)	230 (165-330)	
			● ●	VP15TF	M	330 (260-425)	295 (230-395)	230 (165-330)	230 (165-330)	
	Ferritic and Martensitic Stainless Steels	-	● ● ✦	MP7130	M	395 (330-490)	360 (295-460)	295 (230-395)	295 (230-395)	
			● ●	VP15TF	M	395 (330-490)	360 (295-460)	295 (230-395)	295 (230-395)	
	Precipitation Hardening Stainless Steels	<450HB	● ● ✦	MP7130	M	295 (230-395)	260 (195-360)	195 (130-295)	195 (130-295)	
			● ●	VP15TF	M	295 (230-395)	260 (195-360)	195 (130-295)	195 (130-295)	
	K	Gray Cast Irons	Tensile Strength ≤350MPa	● ●	MC5020	M	590 (525-720)	560 (490-690)	490 (425-620)	490 (425-620)
				● ● ✦	VP15TF	M	425 (330-490)	395 (295-460)	330 (260-395)	330 (260-395)
Ductile Cast Irons		Tensile Strength ≤800MPa	● ●	MC5020	M	525 (460-590)	490 (425-560)	425 (360-490)	425 (360-490)	
			● ● ✦	VP15TF	M	360 (260-460)	330 (230-425)	260 (195-395)	260 (195-395)	
N	Aluminum Alloys	Si<5%	● ● ✦	TF15	M	1970 (1310-3280)	1970 (1310-3280)	1970 (1310-3280)	1970 (1310-3280)	
S	Titanium Alloys (Ti-6Al-4V, etc.)	-	● ●	MP9120	M	165 (130-230)	165 (130-230)	165 (130-230)	165 (130-230)	
			● ●	VP15TF	M	165 (130-230)	165 (130-230)	165 (130-230)	165 (130-230)	
			✦	MP9130	M	130 (100-195)	130 (100-195)	130 (100-195)	130 (100-195)	
	Titanium Alloys (Ti-5Al-5V-5Mo-3Cr, etc.)	-	● ●	MP9120	M	100 (65-130)	100 (65-130)	100 (65-130)	100 (65-130)	
			● ●	VP15TF	M	100 (65-130)	100 (65-130)	100 (65-130)	100 (65-130)	
			✦	MP9130	M	100 (65-130)	100 (65-130)	100 (65-130)	100 (65-130)	
	Heat Resistant Alloys	-	● ●	MP9120	M	130 (100-195)	130 (100-195)	130 (100-195)	130 (100-195)	
			● ●	VP15TF	M	130 (100-195)	130 (100-195)	130 (100-195)	130 (100-195)	
			✦	MP9130	M	100 (65-130)	100 (65-130)	100 (65-130)	100 (65-130)	
H	Hardened Steels	40-55HRC	● ● ✦	VP15TF	M	295 (230-330)	280 (195-330)	230 (165-260)	230 (165-260)	

Note 1) These cutting conditions should be referenced for standard shank types (last letter in designation is S) and arbor shank types. If there is chatter, insert chipping, etc. during machining, alter conditions accordingly.

Note 2) Chattering vibration is more likely under the following circumstances. Use a cut and feed per tooth that are at minimum recommended conditions or below.

- When tool overhang is long (using a long shank, screw-in type, etc.)
- Rigidity of machine, workpiece material or attachment of workpiece material is low
- Corner radius during pocket milling

Note 3) A type with fewer teeth is recommended when the depth of cut in the radius direction (ae) is .5 DC or more.

Note 4) Wet cutting is recommended, when focusing on the surface finish. (Tool life is shorter than for dry cutting.)

Note 5) When using under higher than recommended cutting conditions, or for long periods of time, the clamp screw may become fatigued and break during machining. Please change out the clamp screw periodically.

VPX200 Recommended Cutting Conditions

Wet Cutting

Depth of Cut / Feed per Tooth

(inch)

Workpiece Material	Properties	Cutting Width ae	Cutting Conditions	Cutter Diameter DC						
				ø.625-ø.750(ø16mm-ø18mm)		ø.875-ø1.000(ø20mm-ø25mm)		ø1.125-ø2.500(ø28mm-ø63mm)		
				Depth of Cut ap	Feed per Tooth fz (IPT)	Depth of Cut ap	Feed per Tooth fz (IPT)	Depth of Cut ap	Feed per Tooth fz (IPT)	
P	Mild Steels	≤.25DC	● ● *	≤.236	.004-.006	≤.315	.004-.008	≤.315	.004-.010	
		.25-.5DC	● ● *	≤.197	.004-.006	≤.315	.004-.006	≤.315	.004-.008	
		.5-.75DC	● ● *	≤.157	.003-.005	≤.236	.003-.005	≤.236	.004-.006	
		DC(Slot)	● ● *	≤.079	.002-.004	≤.157	.002-.004	≤.157	.003-.005	
	Carbon Steels Alloy Steels Alloy Tool Steels	180-280HB	≤.25DC	● ● *	≤.236	.004-.006	≤.315	.004-.008	≤.315	.004-.010
		.25-.5DC	● ● *	≤.197	.003-.005	≤.315	.004-.006	≤.315	.004-.008	
		.5-.75DC	● ● *	≤.157	.003-.005	≤.236	.003-.005	≤.236	.004-.006	
		DC(Slot)	● ● *	≤.079	.002-.004	≤.157	.002-.004	≤.157	.003-.005	
	Carbon Steels Alloy Steels Alloy Tool Steels	280-350HB ≤350HB (Annealing)	≤.25DC	● ● *	≤.236	.004-.006	≤.315	.004-.006	≤.315	.004-.008
		.25-.5DC	● ● *	≤.197	.003-.005	≤.315	.003-.005	≤.315	.004-.006	
		.5-.75DC	● ● *	≤.157	.003-.005	≤.236	.002-.004	≤.236	.003-.005	
		DC(Slot)	● ● *	≤.079	.002-.004	≤.157	.002-.004	≤.157	.002-.004	
Pre-hardened Steels	35-45HRC	≤.25DC	● ● *	≤.236	.004-.006	≤.315	.004-.006	≤.315	.004-.008	
	.25-.5DC	● ● *	≤.197	.003-.005	≤.315	.003-.005	≤.315	.004-.006		
	.5-.75DC	● ● *	≤.157	.003-.005	≤.236	.002-.004	≤.236	.003-.005		
	DC(Slot)	● ● *	≤.079	.002-.004	≤.157	.002-.004	≤.157	.002-.004		
M	Austenitic Stainless Steels	≤.25DC	● ● *	≤.236	.004-.006	≤.315	.004-.008	≤.315	.004-.008	
		.25-.5DC	● ● *	≤.197	.003-.005	≤.315	.003-.006	≤.315	.003-.006	
		.5-.75DC	● ● *	≤.157	.002-.004	≤.236	.003-.005	≤.236	.003-.005	
		DC(Slot)	● ● *	≤.079	.002-.004	≤.157	.002-.004	≤.157	.002-.004	
	Duplex Stainless Steels	≤280HB	≤.25DC	● ● *	≤.236	.004-.006	≤.315	.004-.008	≤.315	.004-.008
		.25-.5DC	● ● *	≤.197	.003-.005	≤.315	.003-.006	≤.315	.003-.006	
		.5-.75DC	● ● *	≤.157	.002-.004	≤.236	.003-.005	≤.236	.003-.005	
		DC(Slot)	● ● *	≤.079	.002-.004	≤.157	.002-.004	≤.157	.002-.004	
	Ferritic and Martensitic Stainless Steels	—	≤.25DC	● ● *	≤.236	.004-.006	≤.315	.004-.008	≤.315	.004-.008
		.25-.5DC	● ● *	≤.197	.003-.005	≤.315	.003-.006	≤.315	.003-.006	
		.5-.75DC	● ● *	≤.157	.002-.004	≤.236	.003-.005	≤.236	.003-.005	
		DC(Slot)	● ● *	≤.079	.002-.004	≤.157	.002-.004	≤.157	.002-.004	
	Precipitation Harden- ing Stainless Steels	<450HB	≤.25DC	● ● *	≤.236	.004-.006	≤.315	.004-.006	≤.315	.004-.006
		.25-.5DC	● ● *	≤.197	.003-.005	≤.315	.003-.005	≤.315	.003-.005	
		.5-.75DC	● ● *	≤.157	.002-.004	≤.236	.003-.005	≤.236	.003-.005	
		DC(Slot)	● ● *	≤.079	.002-.004	≤.157	.002-.004	≤.157	.002-.004	

- Note 1) These cutting conditions should be referenced for standard shank types (last letter in designation is S) and arbor shank types. If there is chatter, insert chipping, etc. during machining, alter conditions accordingly.
- Note 2) Chattering vibration is more likely under the following circumstances. Use a cut and feed per tooth that are at minimum recommended conditions or below.
- When tool overhang is long (using a long shank, screw-in type, etc.)
 - Rigidity of machine, workpiece material or attachment of workpiece material is low
 - Corner radius during pocket milling
- Note 3) A type with fewer teeth is recommended when the depth of cut in the radius direction (ae) is .5 DC or more.
- Note 4) Wet cutting is recommended, when focusing on the surface finish. (Tool life is shorter than for dry cutting.)
- Note 5) When using under higher than recommended cutting conditions, or for long periods of time, the clamp screw may become fatigued and break during machining. Please change out the clamp screw periodically.

Cutting Conditions (Guide) :

● : Stable Cutting ● : General Cutting ✖ : Unstable Cutting

VPX200 Recommended Cutting Conditions

(inch)

Workpiece Material	Properties	Cutting Width ae	Cutting Conditions	Cutter Diameter DC					
				ø.625-ø.750(ø16mm-ø18mm)		ø.875-ø1.000(ø20mm-ø25mm)		ø1.125-ø2.500(ø28mm-ø63mm)	
				Depth of Cut ap	Feed per Tooth fz (IPT)	Depth of Cut ap	Feed per Tooth fz (IPT)	Depth of Cut ap	Feed per Tooth fz (IPT)
K	Gray Cast Irons	≤.25DC	● ●	≤.236	.004-.006	≤.315	.004-.008	≤.315	.004-.010
			● ● ✖	≤.236	.003-.005	≤.315	.003-.006	≤.315	.004-.008
		.25-.5DC	● ● ✖	≤.197	.003-.005	≤.315	.003-.006	≤.315	.004-.008
			● ● ✖	≤.197	.002-.004	≤.315	.003-.005	≤.315	.004-.006
	.5-.75DC	● ●	≤.157	.003-.005	≤.236	.002-.004	≤.236	.004-.006	
		● ● ✖	≤.157	.003-.005	≤.236	.002-.004	≤.236	.003-.005	
	DC(Slot)	● ●	≤.079	.002-.004	≤.157	.002-.004	≤.157	.003-.006	
		● ● ✖	≤.079	.002-.003	≤.157	.002-.003	≤.157	.002-.004	
Ductile Cast Irons	Tensile Strength ≤350MPa	≤.25DC	● ●	≤.236	.004-.006	≤.315	.004-.008	≤.315	.004-.008
			● ● ✖	≤.236	.003-.005	≤.315	.004-.006	≤.315	.004-.006
		.25-.5DC	● ● ✖	≤.197	.003-.005	≤.315	.004-.006	≤.315	.004-.006
			● ● ✖	≤.197	.002-.004	≤.315	.003-.005	≤.315	.003-.005
	.5-.75DC	● ●	≤.157	.003-.005	≤.236	.003-.005	≤.236	.003-.005	
		● ● ✖	≤.157	.003-.005	≤.236	.003-.005	≤.236	.002-.004	
	DC(Slot)	● ●	≤.079	.002-.004	≤.157	.002-.004	≤.157	.002-.004	
		● ● ✖	≤.079	.002-.003	≤.157	.002-.003	≤.157	.002-.003	
N	Aluminum Alloys	≤.25DC	● ●	≤.236	.004-.008	≤.315	.004-.010	≤.315	.004-.010
			● ● ✖	≤.236	.004-.006	≤.315	.004-.008	≤.315	.004-.008
		.25-.5DC	● ●	≤.197	.004-.006	≤.315	.004-.008	≤.315	.004-.008
			● ● ✖	≤.197	.003-.005	≤.315	.004-.006	≤.315	.004-.006
	.5-.75DC	● ●	≤.157	.003-.005	≤.236	.002-.006	≤.236	.003-.006	
		● ● ✖	≤.157	.002-.004	≤.236	.002-.006	≤.236	.003-.006	
	DC(Slot)	● ●	≤.079	.002-.004	≤.157	.002-.006	≤.157	.003-.006	
		● ● ✖	≤.079	.002-.003	≤.157	.002-.005	≤.157	.003-.005	
S	Titanium Alloys (Ti-6Al-4V,etc.)	≤.25DC	● ● ✖	≤.236	.003-.006	≤.315	.003-.006	≤.315	.003-.006
			● ● ✖	≤.197	.003-.005	≤.315	.003-.005	≤.315	.003-.005
		.25-.5DC	● ● ✖	≤.197	.003-.005	≤.315	.003-.005	≤.315	.003-.005
			● ● ✖	≤.157	.002-.004	≤.236	.002-.004	≤.236	.002-.004
	Titanium Alloys (Ti-5Al-5V-5Mo-3Cr,etc.)	≤.25DC	● ● ✖	≤.236	.003-.005	≤.315	.003-.005	≤.315	.003-.005
			● ● ✖	≤.197	.003-.005	≤.315	.003-.005	≤.315	.003-.005
		.25-.5DC	● ● ✖	≤.197	.003-.005	≤.315	.003-.005	≤.315	.003-.005
			● ● ✖	≤.157	.002-.004	≤.236	.002-.004	≤.236	.002-.004
	Heat Resistant Al- loys	≤.25DC	● ● ✖	≤.236	.003-.005	≤.315	.003-.005	≤.315	.003-.005
			● ● ✖	≤.197	.003-.005	≤.315	.003-.005	≤.315	.003-.005
		.25-.5DC	● ● ✖	≤.197	.003-.005	≤.315	.003-.005	≤.315	.003-.005
			● ● ✖	≤.157	.002-.004	≤.236	.002-.004	≤.236	.002-.004
H	Hardened Steels	≤.25DC	● ●	≤.157	.003-.006	≤.157	.003-.006	≤.157	.003-.006
			● ● ✖	≤.157	.003-.005	≤.157	.003-.005	≤.157	.003-.005
		.25-.5DC	● ●	≤.118	.003-.005	≤.118	.003-.005	≤.118	.003-.005
			● ● ✖	≤.118	.002-.004	≤.118	.002-.004	≤.118	.002-.004
	.5-.75DC	● ●	≤.079	.002-.004	≤.079	.002-.004	≤.079	.002-.004	
		● ● ✖	≤.079	.002-.004	≤.079	.002-.004	≤.079	.002-.004	
	DC(Slot)	● ●	≤.039	.002-.004	≤.039	.002-.004	≤.039	.002-.004	
		● ● ✖	≤.039	.002-.004	≤.039	.002-.004	≤.039	.002-.004	

Note 1) These cutting conditions should be referenced for standard shank types (last letter in designation is S) and arbor shank types. If there is chatter, insert chipping, etc. during machining, alter conditions accordingly.

Note 2) Chattering vibration is more likely under the following circumstances. Use a cut and feed per tooth that are at minimum recommended conditions or below.

- When tool overhang is long (using a long shank, screw-in type, etc.)
- Rigidity of machine, workpiece material or attachment of workpiece material is low
- Corner radius during pocket milling

Note 3) A type with fewer teeth is recommended when the depth of cut in the radius direction (ae) is .5 DC or more.

Note 4) Wet cutting is recommended, when focusing on the surface finish. (Tool life is shorter than for dry cutting.)

Note 5) When using under higher than recommended cutting conditions, or for long periods of time, the clamp screw may become fatigued and break during machining. Please change out the clamp screw periodically.

VPX200

Recommended Cutting Conditions

Ramping / Helical Milling

● Ramping

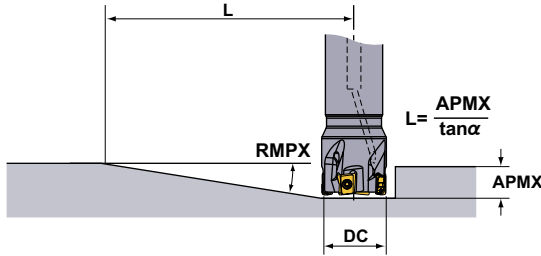

● Helical Milling

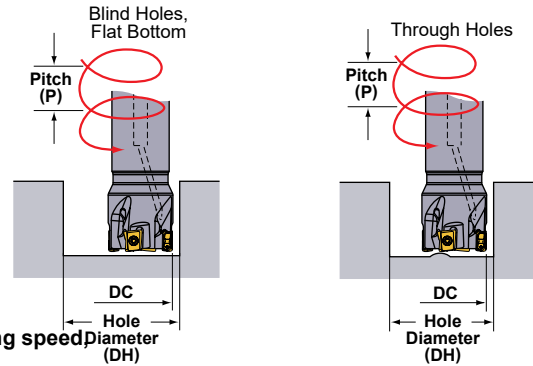

Refer to the table below for cutting conditions. For feed per tooth and cutting speed follow the cutting conditions for slot milling.

Cutting Edge Diameter DC	RE	Ramping		Helical Milling (Blind Hole, Flat Bottom)				Helical Milling (Through Hole)	
		Maximum Ramping Angle RMPX	Minimum Distance L*	Maximum Hole Diameter DH max.	Maximum Pitch P max.	Minimum Hole Diameter DH min.	Maximum Pitch P max.	Minimum Hole Diameter DH min.	Maximum Pitch P max.
.625	.008	1.87°	9.7	1.213	.060	1.072	.046	.942	.032
	.016	1.87°	9.7	1.197	.059	1.073	.046	.942	.032
	.031	1.87°	9.7	1.165	.055	1.073	.046	.942	.032
	.039	1.87°	9.7	1.150	.054	1.073	.046	.942	.032
	.047	1.87°	9.7	1.134	.052	1.073	.046	.942	.032
.063	1.87°	9.7	1.102	.049	1.073	.046	.942	.032	
.750	.008	1.43°	12.6	1.463	.056	1.323	.045	1.187	.034
	.016	1.43°	12.6	1.447	.055	1.323	.045	1.187	.034
	.031	1.43°	12.6	1.415	.052	1.323	.045	1.187	.034
	.039	1.43°	12.6	1.400	.051	1.323	.045	1.187	.034
	.047	1.43°	12.6	1.384	.050	1.323	.045	1.187	.034
.063	1.43°	12.6	1.352	.047	1.323	.045	1.187	.034	
.875	.008	1.14°	15.9	1.713	.052	1.574	.044	1.435	.035
	.016	1.14°	15.9	1.697	.051	1.574	.044	1.435	.035
	.031	1.14°	15.9	1.665	.049	1.574	.044	1.435	.035
	.039	1.14°	15.9	1.650	.048	1.574	.044	1.435	.035
	.047	1.14°	15.9	1.634	.047	1.574	.044	1.435	.035
.063	1.14°	15.9	1.602	.045	1.575	.044	1.435	.035	
1.000	.008	.95°	19.0	1.963	.050	1.824	.043	1.685	.036
	.016	.95°	19.0	1.947	.049	1.824	.043	1.685	.036
	.031	.95°	19.0	1.915	.048	1.824	.043	1.685	.036
	.039	.95°	19.0	1.900	.047	1.824	.043	1.685	.036
	.047	.95°	19.0	1.884	.046	1.824	.043	1.685	.036
.063	.95°	19.0	1.852	.044	1.825	.043	1.685	.036	
1.125	.008	.82°	22.0	2.213	.049	2.074	.043	1.935	.036
	.016	.82°	22.0	2.197	.048	2.074	.043	1.935	.036
	.031	.82°	22.0	2.165	.047	2.074	.043	1.935	.036
	.039	.82°	22.0	2.150	.046	2.074	.043	1.935	.036
	.047	.82°	22.0	2.134	.045	2.074	.043	1.935	.036
.063	.82°	22.0	2.102	.044	2.075	.043	1.935	.036	
1.250	.008	.71°	25.4	2.463	.047	2.320	.042	2.183	.036
	.016	.71°	25.4	2.447	.047	2.320	.042	2.183	.036
	.031	.71°	25.4	2.415	.045	2.320	.042	2.183	.036
	.039	.71°	25.4	2.400	.045	2.320	.042	2.183	.036
	.047	.71°	25.4	2.384	.044	2.320	.042	2.183	.036
.063	.71°	25.4	2.352	.043	2.321	.042	2.183	.036	

Note 1) When machining a highly ductile workpiece material with the ramping angles in the table above, chips may be elongated.
 * Shows the distance until a maximum depth of cut of .315" is achieved at the maximum ramping angle L (= .315"/tan α).

VPX200 Recommended Cutting Conditions

(inch)

Cutting Edge Diameter DC	RE	Ramping		Helical Milling (Blind Hole, Flat Bottom)				Helical Milling (Through Hole)	
		Maximum Ramping Angle RMPX	Minimum Distance* L	Maximum Hole Diameter DH max.	Maximum Pitch P max.	Minimum Hole Diameter DH min.	Maximum Pitch P max.	Minimum Hole Diameter DH min.	Maximum Pitch P max.
1.375	.008	.64°	28.2	2.713	.047	2.574	.042	2.435	.037
	.016	.64°	28.2	2.697	.046	2.574	.042	2.435	.037
	.031	.64°	28.2	2.665	.045	2.574	.042	2.435	.037
	.039	.64°	28.2	2.650	.045	2.574	.042	2.435	.037
	.047	.64°	28.2	2.634	.044	2.574	.042	2.435	.037
	.063	.64°	28.2	2.602	.043	2.574	.042	2.435	.037
1.500	.008	.57°	31.7	2.963	.046	2.820	.041	2.683	.037
	.016	.57°	31.7	2.947	.045	2.820	.041	2.683	.037
	.031	.57°	31.7	2.915	.044	2.820	.041	2.683	.037
	.039	.57°	31.7	2.900	.044	2.820	.041	2.683	.037
	.047	.57°	31.7	2.884	.043	2.820	.041	2.683	.037
	.063	.57°	31.7	2.852	.042	2.821	.041	2.683	.037
2.000	.008	.41°	44.0	3.963	.044	3.820	.041	3.683	.038
	.016	.41°	44.0	3.947	.044	3.820	.041	3.683	.038
	.031	.41°	44.0	3.915	.043	3.820	.041	3.683	.038
	.039	.41°	44.0	3.900	.043	3.820	.041	3.683	.038
	.047	.41°	44.0	3.884	.042	3.820	.041	3.683	.038
	.063	.41°	44.0	3.852	.042	3.820	.041	3.683	.038
2.500	.008	.32°	56.4	4.963	.043	4.820	.041	4.683	.038
	.016	.32°	56.4	4.947	.043	4.820	.041	4.683	.038
	.031	.32°	56.4	4.915	.042	4.820	.041	4.683	.038
	.039	.32°	56.4	4.900	.042	4.820	.041	4.683	.038
	.047	.32°	56.4	4.884	.042	4.820	.041	4.683	.038
	.063	.32°	56.4	4.852	.041	4.820	.041	4.683	.038

Note 1) When machining a highly ductile workpiece material with the ramping angles in the table above, chips may be elongated.
 * Shows the distance until a maximum depth of cut of .315" is achieved at the maximum ramping angle L (= .315"/tan α).

VPX200

Recommended Cutting Conditions

For Plunging and Drilling

See the tables to the right for cutting conditions. Follow the cutting conditions for slot milling regarding feed per tooth and cutting speed.

● Plunging

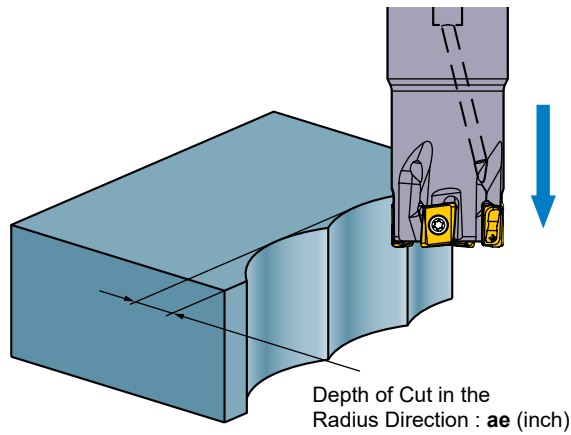

Note 1) No step feed necessary.

DC	ae max. (inch)
.625	.154
.750	.154
.875	.157
1.000	.157
1.125	.157
1.250	.157
1.375	.157
1.500	.157
2.000	.157
2.500	.157

● Drilling

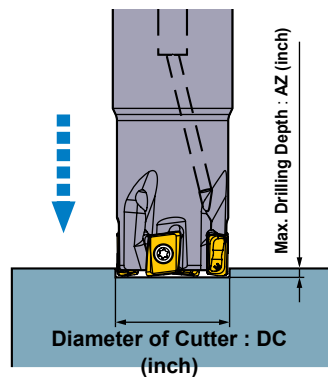

Note 1) Exercise due caution as chips scatter easily.

Note 2) Use compressed air to eliminate chips (or coolant for when machining aluminum alloy).

DC	AZ max. (inch)
.625	.012
.750	.012
.875	.012
1.000	.012
1.125	.012
1.250	.012
1.375	.012
1.500	.012
2.000	.012
2.500	.012



VPX300 Recommended Cutting Conditions

Dry Cutting Cutting Speed

(inch)

Workpiece Material	Properties	Cutting Conditions	Insert		Cutting Width ae					
			Grade	Chip Breaker	≤.25DC	.25-.5DC	.5-.75DC	DC(Slot)		
					Cutting Speed vc (SFM)					
P	Mild Steels	≤180HB	● ●	MP6120	M	755 (590-885)	720 (560-850)	590 (460-690)	590 (460-690)	
			● ●	VP15TF	M	755 (590-885)	720 (560-850)	590 (460-690)	590 (460-690)	
			✱	MP6130	M	655 (490-785)	620 (560-850)	490 (360-590)	490 (360-590)	
	Carbon Steels Alloy Steels Alloy Tool Steels	180-350HB ≤350HB (Annealing)	● ●	MP6120	M	590 (460-690)	560 (425-655)	460 (360-525)	460 (360-590)	
			● ●	VP15TF	M	590 (460-690)	560 (425-655)	460 (360-525)	460 (360-590)	
			✱	MP6130	M	490 (360-590)	460 (330-560)	360 (260-425)	360 (260-425)	
	Pre-hardened Steels	35-45HRC	● ●	MP6120	M	395 (295-460)	360 (260-425)	330 (230-395)	330 (230-395)	
			● ●	VP15TF	M	395 (295-460)	360 (260-425)	330 (230-395)	330 (230-395)	
			✱	MP6130	M	330 (260-395)	295 (230-360)	260 (195-330)	260 (195-330)	
M	Austenitic Stainless Steels	≤200HB	● ● ✱	MP7130	M	590 (460-690)	560 (425-655)	460 (360-525)	460 (360-525)	
			● ● ✱	VP15TF	M	590 (460-690)	560 (425-655)	460 (360-525)	460 (360-525)	
		>200HB	● ● ✱	MP7130	M	490 (360-590)	460 (330-525)	360 (260-425)	360 (260-425)	
			● ● ✱	VP15TF	M	490 (360-590)	460 (330-525)	360 (260-425)	360 (260-425)	
	Duplex Stainless Steels	≤280HB	● ● ✱	MP7130	M	460 (360-560)	425 (295-490)	330 (230-395)	330 (230-395)	
			● ● ✱	VP15TF	M	460 (360-560)	425 (295-490)	330 (230-395)	330 (230-395)	
	Ferritic and Martensitic Stainless Steels	-	● ● ✱	MP7130	M	590 (460-690)	560 (425-655)	460 (360-525)	460 (360-525)	
			● ● ✱	VP15TF	M	590 (460-690)	560 (425-655)	460 (360-525)	460 (360-525)	
	Precipitation Hardening Stainless Steels	<450HB	● ● ✱	MP7130	M	425 (330-525)	395 (260-460)	295 (195-360)	295 (195-360)	
			● ● ✱	VP15TF	M	425 (330-525)	395 (260-460)	295 (195-360)	295 (195-360)	
	K	Gray Cast Irons	Tensile Strength ≤350MPa	● ●	MC5020	M	820 (655-985)	785 (620-950)	690 (525-850)	690 (525-850)
				● ● ✱	VP15TF	M	655 (490-820)	620 (460-785)	525 (360-690)	525 (360-690)
Ductile Cast Irons		Tensile Strength ≤800MPa	● ●	MC5020	M	590 (490-655)	560 (460-620)	490 (395-560)	490 (395-560)	
			● ● ✱	VP15TF	M	425 (330-490)	395 (295-460)	330 (260-395)	330 (260-395)	
N	Aluminum Alloys	Si <5%	● ● ✱	TF15	M	1970 (1310-3280)	1970 (1310-3280)	1970 (1310-3280)	1970 (1310-3280)	
H	Hardened Steels	40-55HRC	● ● ✱	VP15TF	M	295 (230-330)	280 (195-330)	230 (165-260)	230 (165-260)	

- Note 1) These cutting conditions should be referenced for standard shank types (last letter in designation is S) and arbor shank types. If there is chatter, insert chipping, etc. during machining, alter conditions accordingly.
- Note 2) Chattering vibration is more likely under the following circumstances. Use a cut and feed per tooth that are at minimum recommended conditions or below.
- When tool overhang is long (using a long shank, screw-in type, etc.)
 - Rigidity of machine, workpiece material or attachment of workpiece material is low
 - Corner radius during pocket milling
- Note 3) A type with fewer teeth is recommended when the depth of cut in the radius direction (ae) is .5 DC or more.
- Note 4) Wet cutting is recommended, when focusing on the surface finish. (Tool life is shorter than for dry cutting.)
- Note 5) When using under higher than recommended cutting conditions, or for long periods of time, the clamp screw may become fatigued and break during machining. Please change out the clamp screw periodically.

Cutting Conditions (Guide) :

● : Stable Cutting ● : General Cutting ✖ : Unstable Cutting

Depth of Cut / Feed per Tooth

(inch)

Workpiece Material	Properties	Cutting Width ae	Cutting Conditions	Cutter Diameter DC				
				ø1.000 (ø25mm)		ø1.125-ø3.000 (ø28mm-ø80mm)		
				Depth of Cut ap	Feed per Tooth. fz (IPT)	Depth of Cut ap	Feed per Tooth. fz (IPT)	
P	Mild Steels	≤.25DC	● ● ✖	≤.433	.004-.008	≤.433	.004-.012	
		.25-.5DC	● ● ✖	≤.433	.004-.006	≤.433	.004-.010	
		.5-.75DC	● ● ✖	≤.315	.003-.005	≤.315	.004-.008	
		DC(Slot)	● ● ✖	≤.197	.002-.004	≤.197	.003-.006	
	Carbon Steels Alloy Steels Alloy Tool Steels	180-280HB	≤.25DC	● ● ✖	≤.433	.004-.008	≤.433	.004-.012
		.25-.5DC	● ● ✖	≤.433	.004-.006	≤.433	.004-.010	
		.5-.75DC	● ● ✖	≤.315	.003-.005	≤.315	.004-.008	
		DC(Slot)	● ● ✖	≤.197	.002-.004	≤.197	.003-.006	
	Carbon Steels Alloy Steels Alloy Tool Steels	280-350HB ≤350HB (Annealing)	≤.25DC	● ● ✖	≤.433	.004-.006	≤.433	.004-.010
		.25-.5DC	● ● ✖	≤.433	.003-.005	≤.433	.004-.008	
		.5-.75DC	● ● ✖	≤.315	.002-.004	≤.315	.004-.006	
		DC(Slot)	● ● ✖	≤.197	.002-.004	≤.197	.003-.005	
	Pre-hardened Steels	35-45HRC	≤.25DC	● ● ✖	≤.433	.004-.006	≤.433	.004-.010
		.25-.5DC	● ● ✖	≤.433	.003-.005	≤.433	.004-.008	
		.5-.75DC	● ● ✖	≤.315	.002-.004	≤.315	.004-.006	
		DC(Slot)	● ● ✖	≤.197	.002-.004	≤.197	.003-.005	
M	Austenitic Stainless Steels	≤.25DC	● ● ✖	≤.433	.004-.008	≤.433	.004-.008	
			● ● ✖	≤.433	.003-.006	≤.433	.003-.006	
		.25-.5DC	● ● ✖	≤.433	.003-.006	≤.433	.003-.006	
			● ● ✖	≤.433	.003-.005	≤.433	.003-.005	
		.5-.75DC	● ● ✖	≤.315	.003-.005	≤.315	.003-.005	
			● ● ✖	≤.315	.002-.004	≤.315	.002-.004	
		DC(Slot)	● ● ✖	≤.197	.002-.004	≤.197	.002-.004	
			● ● ✖	≤.197	.002-.003	≤.197	.002-.003	
	Duplex Stainless Steels	≤280HB	≤.25DC	● ● ✖	≤.433	.004-.008	≤.433	.004-.008
			● ● ✖	≤.433	.003-.006	≤.433	.003-.006	
		.25-.5DC	● ● ✖	≤.433	.003-.006	≤.433	.003-.006	
			● ● ✖	≤.433	.003-.005	≤.433	.003-.005	
		.5-.75DC	● ● ✖	≤.315	.003-.005	≤.315	.003-.005	
			● ● ✖	≤.315	.002-.004	≤.315	.002-.004	
		DC(Slot)	● ● ✖	≤.197	.002-.004	≤.197	.002-.004	
			● ● ✖	≤.197	.002-.003	≤.197	.002-.003	
	Ferritic and Martensitic Stainless Steels	-	≤.25DC	● ● ✖	≤.433	.004-.008	≤.433	.004-.008
			● ● ✖	≤.433	.003-.006	≤.433	.003-.006	
		.25-.5DC	● ● ✖	≤.433	.003-.006	≤.433	.003-.006	
			● ● ✖	≤.433	.003-.005	≤.433	.003-.005	
.5-.75DC		● ● ✖	≤.315	.003-.005	≤.315	.003-.005		
		● ● ✖	≤.315	.002-.004	≤.315	.002-.004		
DC(Slot)		● ● ✖	≤.197	.002-.004	≤.197	.002-.004		
		● ● ✖	≤.197	.002-.003	≤.197	.002-.003		
Precipitation Hardening Stainless Steels	<450HB	≤.25DC	● ● ✖	≤.433	.004-.006	≤.433	.004-.006	
		● ● ✖	≤.433	.003-.005	≤.433	.003-.005		
	.25-.5DC	● ● ✖	≤.433	.003-.005	≤.433	.003-.005		
		● ● ✖	≤.433	.003-.005	≤.433	.002-.004		
	.5-.75DC	● ● ✖	≤.315	.002-.004	≤.315	.002-.004		
		● ● ✖	≤.315	.002-.003	≤.315	.002-.003		
	DC(Slot)	● ● ✖	≤.197	.002-.004	≤.197	.002-.004		
		● ● ✖	≤.197	.002-.003	≤.197	.002-.003		

Note 1) These cutting conditions should be referenced for standard shank types (last letter in designation is S) and arbor shank types. If there is chatter, insert chipping, etc. during machining, alter conditions accordingly.

Note 2) Chattering vibration is more likely under the following circumstances. Use a cut and feed per tooth that are at minimum recommended conditions or below.

- When tool overhang is long (using a long shank, screw-in type, etc.)
- Rigidity of machine, workpiece material or attachment of workpiece material is low
- Corner radius during pocket milling

Note 3) A type with fewer teeth is recommended when the depth of cut in the radius direction (ae) is .5 DC or more.

Note 4) Wet cutting is recommended, when focusing on the surface finish. (Tool life is shorter than for dry cutting.)

Note 5) When using under higher than recommended cutting conditions, or for long periods of time, the clamp screw may become fatigued and break during machining. Please change out the clamp screw periodically.

* See Index on page 4 for table icon reference. (●, ★, □)

VPX300 Recommended Cutting Conditions

Dry Cutting

Depth of Cut / Feed per Tooth

(inch)

Workpiece Material	Properties	Cutting Width ae	Cutting Conditions	Cutter Diameter DC					
				ø1.000 (ø25mm)		ø1.125-ø3.000 (ø28mm-ø80mm)			
				Depth of Cut ap	Feed per Tooth. fz (IPT)	Depth of Cut ap	Feed per Tooth. fz (IPT)		
K	Gray Cast Irons Tensile Strength ≤350MPa	≤.25DC	● ●	≤.433	.004-.008	≤.433	.004-.012		
			● ● ✱	≤.433	.003-.006	≤.433	.004-.010		
		.25-.5DC	● ●	≤.433	.003-.006	≤.433	.004-.010		
			● ● ✱	≤.433	.003-.005	≤.433	.004-.008		
		.5-.75DC	● ●	≤.315	.003-.005	≤.315	.004-.008		
			● ● ✱	≤.315	.002-.004	≤.315	.003-.006		
		DC(Slot)	● ●	≤.197	.002-.004	≤.197	.003-.006		
			● ● ✱	≤.197	.002-.003	≤.197	.003-.005		
		Ductile Cast Irons	Tensile Strength ≤800MPa	≤.25DC	● ●	≤.433	.004-.008	≤.433	.004-.010
					● ● ✱	≤.433	.004-.006	≤.433	.004-.008
.25-.5DC	● ●			≤.433	.004-.006	≤.433	.004-.008		
	● ● ✱			≤.433	.003-.005	≤.433	.004-.006		
.5-.75DC	● ●			≤.315	.003-.005	≤.315	.004-.006		
	● ● ✱			≤.315	.003-.005	≤.315	.003-.005		
DC(Slot)	● ●			≤.197	.002-.004	≤.197	.003-.005		
	● ● ✱			≤.197	.002-.003	≤.197	.002-.004		
N	Aluminum Alloys Si < 5%			≤.25DC	● ●	≤.433	.004-.010	≤.433	.004-.010
					● ● ✱	≤.433	.004-.008	≤.433	.004-.008
		.25-.5DC	● ●	≤.433	.004-.008	≤.433	.004-.008		
			● ● ✱	≤.433	.004-.006	≤.433	.004-.006		
		.5-.75DC	● ●	≤.315	.002-.006	≤.315	.003-.006		
			● ● ✱	≤.315	.002-.006	≤.315	.003-.006		
		DC(Slot)	● ●	≤.197	.002-.006	≤.197	.003-.006		
			● ● ✱	≤.197	.002-.006	≤.197	.003-.005		
		H	Hardened Steels 40-55HRC	≤.25DC	● ●	≤.197	.003-.006	≤.197	.003-.006
					● ● ✱	≤.197	.003-.005	≤.197	.003-.005
.25-.5DC	● ●			≤.157	.003-.005	≤.157	.003-.005		
	● ● ✱			≤.157	.002-.004	≤.157	.002-.004		
.5-.75DC	● ●			≤.118	.002-.004	≤.118	.002-.004		
	● ● ✱			≤.118	.002-.003	≤.118	.002-.003		
DC(Slot)	● ●			≤.079	.002-.004	≤.079	.002-.004		
	● ● ✱			≤.079	.002-.003	≤.079	.002-.003		

Note 1) These cutting conditions should be referenced for standard shank types (last letter in designation is S) and arbor shank types. If there is chatter, insert chipping, etc. during machining, alter conditions accordingly.

Note 2) Chattering vibration is more likely under the following circumstances. Use a cut and feed per tooth that are at minimum recommended conditions or below.

- When tool overhang is long (using a long shank, screw-in type, etc.)
- Rigidity of machine, workpiece material or attachment of workpiece material is low
- Corner radius during pocket milling

Note 3) A type with fewer teeth is recommended when the depth of cut in the radius direction (ae) is .5 DC or more.

Note 4) Wet cutting is recommended, when focusing on the surface finish. (Tool life is shorter than for dry cutting.)

Note 5) When using under higher than recommended cutting conditions, or for long periods of time, the clamp screw may become fatigued and break during machining. Please change out the clamp screw periodically.

VPX300

Recommended Cutting Conditions

Wet Cutting ■
Cutting Speed

(inch)

Workpiece Material	Properties	Cutting Conditions	Insert		Cutting Width ae				
			Grade	Chip Breaker	≤.25DC	.25-.5DC	.5-.75DC	DC(Slot)	
					Cutting Speed vc (SFM)				
P Mild Steels	≤180HB	● ●	MP6120	M	460 (330-620)	425 (295-590)	330 (230-395)	330 (230-395)	
		● ●	VP15TF	M	460 (330-620)	425 (295-590)	330 (230-395)	330 (230-395)	
		✦	MP6130	M	460 (330-620)	425 (295-590)	330 (230-395)	330 (230-395)	
	Carbon Steels Alloy Steels Alloy Tool Steels	180-350HB ≤350HB (Annealing)	● ●	MP6120	M	395 (295-460)	360 (260-425)	330 (230-395)	330 (230-395)
			● ●	VP15TF	M	395 (295-460)	360 (260-425)	330 (230-395)	330 (230-395)
			✦	MP6130	M	395 (295-460)	360 (260-425)	330 (230-395)	330 (230-395)
	Pre-hardened Steels	35-45HRC	● ●	MP6120	M	330 (260-395)	295 (230-360)	260 (195-330)	260 (195-330)
			● ●	VP15TF	M	330 (260-395)	295 (230-360)	260 (195-330)	260 (195-330)
			✦	MP6130	M	330 (260-395)	295 (230-360)	260 (195-330)	260 (195-330)
M	Austenitic Stainless Steels	● ● ✦	MP7130	M	395 (330-490)	360 (295-460)	295 (230-395)	295 (230-395)	
		● ● ✦	VP15TF	M	395 (330-490)	360 (295-460)	295 (230-395)	295 (230-395)	
		● ● ✦	MP7130	M	330 (260-425)	295 (230-395)	230 (165-330)	230 (165-330)	
		● ●	VP15TF	M	330 (260-425)	295 (230-395)	230 (165-330)	230 (165-330)	
	Duplex Stainless Steels	≤280HB	● ● ✦	MP7130	M	330 (260-425)	295 (230-395)	230 (165-330)	230 (165-330)
			● ●	VP15TF	M	330 (260-425)	295 (230-395)	230 (165-330)	230 (165-330)
	Ferritic and Martensitic Stainless Steels	-	● ● ✦	MP7130	M	395 (330-490)	360 (295-460)	295 (230-395)	295 (230-395)
			● ●	VP15TF	M	395 (330-490)	360 (295-460)	295 (230-395)	295 (230-395)
	Precipitation Hardening Stainless Steels	<450HB	● ● ✦	MP7130	M	295 (230-395)	260 (195-360)	195 (130-295)	195 (130-295)
			● ●	VP15TF	M	295 (230-395)	260 (195-360)	195 (130-295)	195 (130-295)
	K	Gray Cast Irons	● ●	MC5020	M	590 (525-720)	560 (490-690)	490 (425-620)	490 (425-620)
			● ● ✦	VP15TF	M	425 (330-490)	395 (295-460)	330 (260-395)	330 (260-395)
Ductile Cast Irons		Tensile Strength ≤800MPa	● ●	MC5020	M	525 (460-590)	490 (425-560)	425 (360-490)	425 (360-490)
			● ● ✦	VP15TF	M	360 (260-460)	330 (230-425)	260 (195-395)	260 (195-395)
N	Aluminum Alloys	Si < 5%	● ● ✦	TF15	M	1970 (1310-3280)	1970 (1310-3280)	1970 (1310-3280)	1970 (1310-3280)
S	Titanium Alloys (Ti-6Al-4V, etc.)	-	● ●	MP9120	M	165 (130-230)	165 (130-230)	165 (130-230)	165 (130-230)
			● ●	VP15TF	M	165 (130-230)	165 (130-230)	165 (130-230)	165 (130-230)
			✦	MP9130	M	130 (100-195)	130 (100-195)	130 (100-195)	130 (100-195)
	Titanium Alloys (Ti-5Al-5V-5Mo-3Cr, etc.)	-	● ●	MP9120	M	100 (65-130)	100 (65-130)	100 (65-130)	100 (65-130)
			● ●	VP15TF	M	100 (65-130)	100 (65-130)	100 (65-130)	100 (65-130)
			✦	MP9130	M	100 (65-130)	100 (65-130)	100 (65-130)	100 (65-130)
	Heat Resistant Alloys	-	● ●	MP9120	M	130 (100-195)	130 (100-195)	130 (100-195)	130 (100-195)
			● ● ✦	VP15TF	M	130 (100-195)	130 (100-195)	130 (100-195)	130 (100-195)
H	Hardened Steels	40-55HRC	● ● ✦	VP15TF	M	295 (230-330)	280 (195-330)	230 (165-260)	230 (165-260)

Note 1) These cutting conditions should be referenced for standard shank types (last letter in designation is S) and arbor shank types. If there is chatter, insert chipping, etc. during machining, alter conditions accordingly.

Note 2) Chattering vibration is more likely under the following circumstances. Use a cut and feed per tooth that are at minimum recommended conditions or below.

- When tool overhang is long (using a long shank, screw-in type, etc.)
- Rigidity of machine, workpiece material or attachment of workpiece material is low
- Corner radius during pocket milling

Note 3) A type with fewer teeth is recommended when the depth of cut in the radius direction (ae) is .5 DC or more.

Note 4) Wet cutting is recommended, when focusing on the surface finish. (Tool life is shorter than for dry cutting.)

Note 5) When using under higher than recommended cutting conditions, or for long periods of time, the clamp screw may become fatigued and break during machining. Please change out the clamp screw periodically.

VPX300 Recommended Cutting Conditions

Wet Cutting

Depth of Cut / Feed per Tooth

(inch)

Workpiece Material	Properties	Cutting Width ae	Cutting Conditions	Cutter Diameter DC					
				ø1.000 (ø25mm)		ø1.125–ø3.000 (ø28mm–ø80mm)			
				Depth of Cut ap	Feed per Tooth. fz (IPT)	Depth of Cut ap	Feed per Tooth. fz (IPT)		
P	Mild Steels	≤180HB	≤.25DC	● ● ✱	≤.433	.004–.008	≤.433	.004–.012	
			.25–.5DC	● ● ✱	≤.433	.004–.006	≤.433	.004–.010	
			.5–.75DC	● ● ✱	≤.315	.003–.005	≤.315	.004–.008	
			DC(Slot)	● ● ✱	≤.197	.002–.004	≤.197	.003–.006	
	Carbon Steels Alloy Steels Alloy Tool Steels	180–280HB	≤.25DC	● ● ✱	≤.433	.004–.008	≤.433	.004–.012	
			.25–.5DC	● ● ✱	≤.433	.004–.006	≤.433	.004–.010	
			.5–.75DC	● ● ✱	≤.315	.003–.005	≤.315	.004–.008	
			DC(Slot)	● ● ✱	≤.197	.002–.004	≤.197	.003–.006	
	Carbon Steels Alloy Steels Alloy Tool Steels	280–350HB ≤350HB (Annealing)	≤.25DC	● ● ✱	≤.433	.004–.006	≤.433	.004–.010	
			.25–.5DC	● ● ✱	≤.433	.003–.005	≤.433	.004–.008	
			.5–.75DC	● ● ✱	≤.315	.002–.004	≤.315	.004–.006	
			DC(Slot)	● ● ✱	≤.197	.002–.004	≤.197	.003–.005	
Pre-hardened Steels	35–45HRC	≤.25DC	● ● ✱	≤.433	.004–.006	≤.433	.004–.010		
		.25–.5DC	● ● ✱	≤.433	.003–.005	≤.433	.004–.008		
		.5–.75DC	● ● ✱	≤.315	.002–.004	≤.315	.004–.006		
		DC(Slot)	● ● ✱	≤.197	.002–.004	≤.197	.003–.005		
M	Austenitic Stainless Steels	–	≤.25DC	● ● ✱	≤.433	.004–.008	≤.433	.004–.008	
			.25–.5DC	● ● ✱	≤.433	.003–.006	≤.433	.003–.006	
			.5–.75DC	● ● ✱	≤.433	.003–.005	≤.433	.003–.006	
			DC(Slot)	● ● ✱	≤.433	.002–.004	≤.433	.003–.005	
	Duplex Stainless Steels	≤280HB	≤.25DC	● ● ✱	≤.433	.004–.008	≤.433	.004–.008	
			.25–.5DC	● ● ✱	≤.433	.003–.006	≤.433	.003–.006	
			.5–.75DC	● ● ✱	≤.433	.003–.005	≤.433	.003–.005	
			DC(Slot)	● ● ✱	≤.315	.003–.005	≤.315	.003–.005	
	Ferritic and Martensitic Stainless Steels	–	≤.25DC	● ● ✱	≤.433	.004–.008	≤.433	.004–.008	
			.25–.5DC	● ● ✱	≤.433	.003–.006	≤.433	.003–.006	
			.5–.75DC	● ● ✱	≤.433	.003–.005	≤.433	.003–.005	
			DC(Slot)	● ● ✱	≤.315	.003–.005	≤.315	.003–.005	
	Precipitation Hardening Stainless Steels	<450HB	≤.25DC	● ● ✱	≤.433	.004–.006	≤.433	.004–.006	
			.25–.5DC	● ● ✱	≤.433	.003–.005	≤.433	.003–.005	
			.5–.75DC	● ● ✱	≤.433	.003–.005	≤.433	.003–.005	
			DC(Slot)	● ● ✱	≤.315	.003–.005	≤.315	.003–.005	
				≤.25DC	● ● ✱	≤.433	.004–.006	≤.433	.004–.006
				.25–.5DC	● ● ✱	≤.433	.003–.005	≤.433	.003–.005
				.5–.75DC	● ● ✱	≤.433	.003–.005	≤.433	.003–.005
				DC(Slot)	● ● ✱	≤.315	.003–.005	≤.315	.003–.005
			≤.25DC	● ● ✱	≤.433	.004–.006	≤.433	.004–.006	
			.25–.5DC	● ● ✱	≤.433	.003–.005	≤.433	.003–.005	
			.5–.75DC	● ● ✱	≤.433	.003–.005	≤.433	.003–.005	
			DC(Slot)	● ● ✱	≤.315	.003–.005	≤.315	.003–.005	

Note 1) These cutting conditions should be referenced for standard shank types (last letter in designation is S) and arbor shank types. If there is chatter, insert chipping, etc. during machining, alter conditions accordingly.

Note 2) Chattering vibration is more likely under the following circumstances. Use a cut and feed per tooth that are at minimum recommended conditions or below.

- When tool overhang is long (using a long shank, screw-in type, etc.)
- Rigidity of machine, workpiece material or attachment of workpiece material is low
- Corner radius during pocket milling

Note 3) A type with fewer teeth is recommended when the depth of cut in the radius direction (ae) is .5 DC or more.

Note 4) Wet cutting is recommended, when focusing on the surface finish. (Tool life is shorter than for dry cutting.)

Note 5) When using under higher than recommended cutting conditions, or for long periods of time, the clamp screw may become fatigued and break during machining. Please change out the clamp screw periodically.

Cutting Conditions (Guide) :

● : Stable Cutting ● : General Cutting ✖ : Unstable Cutting

VPX300 Recommended Cutting Conditions

(inch)

Workpiece Material	Properties	Cutting Width ae	Cutting Conditions	Cutter Diameter DC			
				ø1.000 (ø25mm)		ø1.125-ø3.000 (ø28mm-ø80mm)	
				Depth of Cut ap	Feed per Tooth. fz (IPT)	Depth of Cut ap	Feed per Tooth. fz (IPT)
K	Gray Cast Irons	≤.25DC	● ● ✖	≤.433	.004-.008	≤.433	.004-.012
			● ● ✖	≤.433	.003-.006	≤.433	.004-.010
		.25-.5DC	● ● ✖	≤.433	.003-.006	≤.433	.004-.010
			● ● ✖	≤.433	.003-.005	≤.433	.004-.008
	Ductile Cast Irons	.5-.75DC	● ● ✖	≤.315	.003-.005	≤.315	.004-.008
			● ● ✖	≤.315	.002-.004	≤.315	.003-.006
		DC(Slot)	● ● ✖	≤.197	.002-.004	≤.197	.003-.006
			● ● ✖	≤.197	.002-.003	≤.197	.003-.005
N	Aluminum Alloys	≤.25DC	● ● ✖	≤.433	.004-.010	≤.433	.004-.010
			● ● ✖	≤.433	.004-.008	≤.433	.004-.008
		.25-.5DC	● ● ✖	≤.433	.004-.006	≤.433	.004-.008
			● ● ✖	≤.433	.004-.006	≤.433	.004-.006
	Si<5%	.5-.75DC	● ● ✖	≤.315	.002-.006	≤.315	.003-.006
			● ● ✖	≤.315	.002-.006	≤.315	.003-.006
		DC(Slot)	● ● ✖	≤.197	.002-.006	≤.197	.003-.006
			● ● ✖	≤.197	.002-.006	≤.197	.003-.005
S	Titanium Alloys (Ti-6Al-4V, etc.)	≤.25DC	● ● ✖	≤.433	.003-.006	≤.433	.003-.006
			● ● ✖	≤.433	.003-.005	≤.433	.003-.005
		.25-.5DC	● ● ✖	≤.315	.002-.004	≤.315	.002-.004
			● ● ✖	≤.197	.002-.004	≤.197	.002-.004
	Titanium Alloys (Ti-5Al-5V-5Mo-3Cr, etc.)	.5-.75DC	● ● ✖	≤.433	.003-.005	≤.433	.003-.005
			● ● ✖	≤.433	.003-.005	≤.433	.003-.005
		DC(Slot)	● ● ✖	≤.315	.002-.004	≤.315	.002-.004
			● ● ✖	≤.197	.002-.004	≤.197	.002-.004
	Heat Resistant Alloys	≤.25DC	● ● ✖	≤.433	.003-.005	≤.433	.003-.005
			● ● ✖	≤.433	.003-.005	≤.433	.003-.005
		.25-.5DC	● ● ✖	≤.433	.003-.005	≤.433	.003-.005
			● ● ✖	≤.433	.003-.005	≤.433	.003-.005
H	Hardened Steels	40-55HRC	● ● ✖	≤.197	.003-.006	≤.197	.003-.006
			● ● ✖	≤.197	.003-.005	≤.197	.003-.005
		.25-.5DC	● ● ✖	≤.157	.003-.005	≤.157	.003-.005
			● ● ✖	≤.157	.002-.004	≤.157	.002-.004
	40-55HRC	.5-.75DC	● ● ✖	≤.118	.002-.004	≤.118	.002-.004
			● ● ✖	≤.118	.002-.004	≤.118	.002-.003
		DC(Slot)	● ● ✖	≤.079	.002-.004	≤.079	.002-.004
			● ● ✖	≤.079	.002-.004	≤.079	.002-.003

Note 1) These cutting conditions should be referenced for standard shank types (last letter in designation is S) and arbor shank types. If there is chatter, insert chipping, etc. during machining, alter conditions accordingly.

Note 2) Chattering vibration is more likely under the following circumstances. Use a cut and feed per tooth that are at minimum recommended conditions or below.

- When tool overhang is long (using a long shank, screw-in type, etc.)
- Rigidity of machine, workpiece material or attachment of workpiece material is low
- Corner radius during pocket milling

Note 3) A type with fewer teeth is recommended when the depth of cut in the radius direction (ae) is .5 DC or more.

Note 4) Wet cutting is recommended, when focusing on the surface finish. (Tool life is shorter than for dry cutting.)

Note 5) When using under higher than recommended cutting conditions, or for long periods of time, the clamp screw may become fatigued and break during machining. Please change out the clamp screw periodically.

VPX300

Recommended Cutting Conditions

Ramping / Helical Milling

● Ramping

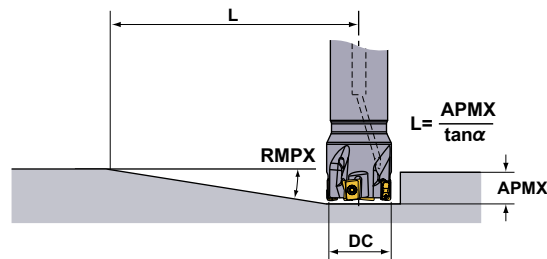

● Helical Milling

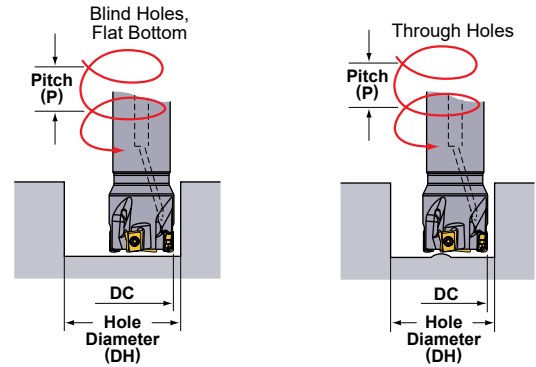

Refer to the table below for cutting conditions. For feed per tooth and cutting speed, follow the cutting conditions for slot milling.

(inch)

Cutting Edge Diameter DC	RE	Ramping		Helical Milling (Blind Hole, Flat Bottom)				Helical Milling (Through Hole)	
		Maximum Ramping Angle RMPX	Minimum Distance* L	Maximum Hole Diameter DH max.	Maximum Pitch P max.	Minimum Hole Diameter DH min.	Maximum Pitch P max.	Minimum Hole Diameter DH min.	Maximum Pitch P max.
1.000	.008	2.07°	12.0	1.963	.109	1.713	.081	1.483	.055
	.016	2.07°	12.0	1.947	.108	1.713	.081	1.483	.055
	.031	2.07°	12.0	1.915	.104	1.713	.081	1.483	.055
	.039	2.07°	12.0	1.900	.102	1.713	.081	1.483	.055
	.047	2.07°	12.0	1.884	.100	1.713	.081	1.483	.055
	.063	2.07°	12.0	1.852	.097	1.713	.081	1.483	.055
	.079	2.07°	12.0	1.821	.093	1.713	.081	1.483	.055
	.094	2.07°	12.0	1.789	.090	1.713	.081	1.483	.055
	.118	2.07°	12.0	1.742	.084	1.713	.081	1.483	.055
.126	2.07°	12.0	1.726	.082	1.713	.081	1.483	.055	
1.125	.008	1.73°	14.4	2.213	.103	1.963	.080	1.726	.057
	.016	1.73°	14.4	2.197	.102	1.963	.080	1.726	.057
	.031	1.73°	14.4	2.165	.099	1.963	.080	1.726	.057
	.039	1.73°	14.4	2.150	.097	1.963	.080	1.726	.057
	.047	1.73°	14.4	2.134	.096	1.963	.080	1.726	.057
	.063	1.73°	14.4	2.102	.093	1.963	.080	1.726	.057
	.079	1.73°	14.4	2.071	.090	1.963	.080	1.726	.057
	.094	1.73°	14.4	2.039	.087	1.963	.080	1.726	.057
	.118	1.73°	14.4	1.992	.082	1.963	.080	1.726	.057
.126	1.73°	14.4	1.976	.081	1.963	.079	1.726	.057	
1.250	.008	1.49°	16.7	2.463	.099	2.214	.079	1.973	.059
	.016	1.49°	16.7	2.447	.098	2.214	.079	1.973	.059
	.031	1.49°	16.7	2.415	.095	2.214	.079	1.973	.059
	.039	1.49°	16.7	2.400	.094	2.214	.079	1.973	.059
	.047	1.49°	16.7	2.384	.093	2.214	.079	1.973	.059
	.063	1.49°	16.7	2.352	.090	2.214	.079	1.973	.059
	.079	1.49°	16.7	2.321	.088	2.214	.079	1.973	.059
	.094	1.49°	16.7	2.289	.085	2.214	.079	1.973	.059
	.118	1.49°	16.7	2.242	.081	2.214	.079	1.973	.059
.126	1.49°	16.7	2.226	.080	2.214	.079	1.973	.059	
1.375	.008	1.28°	19.4	2.713	.094	2.465	.076	2.221	.059
	.016	1.28°	19.4	2.697	.093	2.465	.076	2.221	.059
	.031	1.28°	19.4	2.665	.091	2.465	.076	2.221	.059
	.039	1.28°	19.4	2.650	.089	2.465	.076	2.221	.059
	.047	1.28°	19.4	2.634	.088	2.465	.076	2.221	.059
	.063	1.28°	19.4	2.602	.086	2.465	.076	2.221	.059
	.079	1.28°	19.4	2.571	.084	2.465	.076	2.221	.059
	.094	1.28°	19.4	2.539	.082	2.465	.076	2.221	.059
	.118	1.28°	19.4	2.492	.078	2.465	.077	2.221	.059
.126	1.28°	19.4	2.476	.077	2.465	.077	2.221	.059	

Note 1) When machining a highly ductile workpiece material with the ramping angles in the table above, chips may be elongated.
 * Shows the distance until a maximum depth of cut of .433" is achieved at the maximum ramping angle $L = .433" / \tan \alpha$.

VPX300 Recommended Cutting Conditions

(inch)

Cutting Edge Diameter DC	RE	Ramping		Helical Milling (Blind Hole, Flat Bottom)				Helical Milling (Through Hole)	
		Maximum Ramping Angle RMPX	Minimum Distance L*	Maximum Hole Diameter DH max.	Maximum Pitch P max.	Minimum Hole Diameter DH min.	Maximum Pitch P max.	Minimum Hole Diameter DH min.	Maximum Pitch P max.
1.500	.008	1.13°	22.0	2.963	.091	2.711	.075	2.469	.060
	.016	1.13°	22.0	2.947	.090	2.711	.075	2.469	.060
	.031	1.13°	22.0	2.915	.088	2.711	.075	2.469	.060
	.039	1.13°	22.0	2.900	.087	2.711	.075	2.469	.060
	.047	1.13°	22.0	2.884	.086	2.711	.075	2.469	.060
	.063	1.13°	22.0	2.852	.084	2.711	.075	2.469	.060
	.079	1.13°	22.0	2.821	.082	2.711	.075	2.469	.060
	.094	1.13°	22.0	2.789	.080	2.711	.075	2.469	.060
	.118	1.13°	22.0	2.742	.077	2.711	.075	2.469	.060
.126	1.13°	22.0	2.726	.076	2.711	.075	2.469	.060	
2.000	.008	.78°	31.8	3.963	.084	3.711	.073	3.469	.063
	.016	.78°	31.8	3.947	.083	3.711	.073	3.469	.063
	.031	.78°	31.8	3.915	.082	3.711	.073	3.469	.063
	.039	.78°	31.8	3.900	.081	3.711	.073	3.469	.063
	.047	.78°	31.8	3.884	.081	3.711	.073	3.469	.063
	.063	.78°	31.8	3.852	.079	3.711	.073	3.469	.063
	.079	.78°	31.8	3.821	.078	3.711	.073	3.469	.063
	.094	.78°	31.8	3.789	.077	3.711	.073	3.469	.063
	.118	.78°	31.8	3.742	.075	3.711	.073	3.469	.063
.126	.78°	31.8	3.726	.074	3.711	.073	3.469	.063	
2.500	.008	.59°	42.1	4.963	.080	4.711	.072	4.469	.064
	.016	.59°	42.1	4.947	.079	4.711	.072	4.469	.064
	.031	.59°	42.1	4.915	.078	4.711	.072	4.469	.064
	.039	.59°	42.1	4.900	.078	4.711	.072	4.469	.064
	.047	.59°	42.1	4.884	.077	4.711	.072	4.469	.064
	.063	.59°	42.1	4.852	.076	4.711	.072	4.469	.064
	.079	.59°	42.1	4.821	.075	4.711	.072	4.469	.064
	.094	.59°	42.1	4.789	.074	4.711	.072	4.469	.064
	.118	.59°	42.1	4.742	.073	4.711	.072	4.469	.064
.126	.59°	42.1	4.726	.072	4.711	.072	4.469	.064	
3.000	.008	.48°	51.7	5.955	.078	5.711	.071	5.469	.065
	.016	.48°	51.7	5.939	.077	5.711	.071	5.469	.065
	.031	.48°	51.7	5.907	.077	5.711	.071	5.469	.065
	.039	.48°	51.7	5.892	.076	5.711	.071	5.469	.065
	.047	.48°	51.7	5.876	.076	5.711	.071	5.469	.065
	.063	.48°	51.7	5.844	.075	5.711	.071	5.469	.065
	.079	.48°	51.7	5.813	.074	5.711	.071	5.469	.065
	.094	.48°	51.7	5.781	.073	5.711	.071	5.469	.065
	.118	.48°	51.7	5.734	.072	5.711	.071	5.469	.065
.126	.48°	51.7	5.718	.072	5.711	.071	5.469	.065	

Note 1) When machining a highly ductile workpiece material with the ramping angles in the table above, chips may be elongated.
 * Shows the distance until a maximum depth of cut of .433" is achieved at the maximum ramping angle L (= .433"/tan α).

VPX300

Recommended Cutting Conditions

For Plunging and Drilling

See the tables to the right for cutting conditions. Follow the cutting conditions for slot milling regarding feed per tooth and cutting speed.

● Plunging

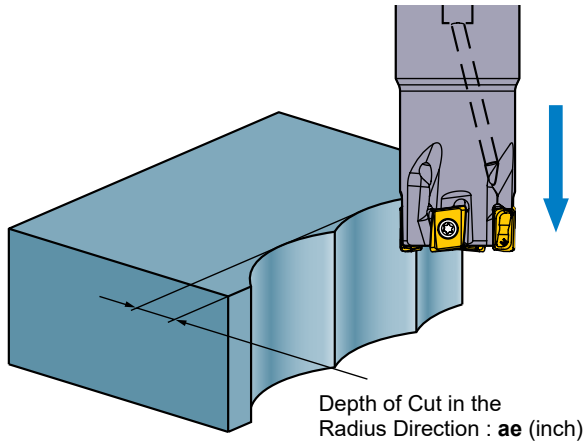

DC	ae max. (inch)
1.000	.256
1.125	.260
1.250	.260
1.375	.260
1.500	.264
2.000	.264
2.500	.264
3.000	.264

Note 1) No step feed necessary.

● Drilling

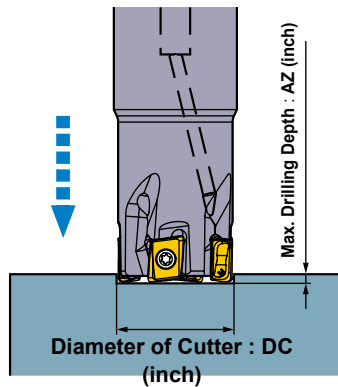

DC	AZ max. (inch)
1.000	.022
1.125	.022
1.250	.022
1.375	.022
1.500	.022
2.000	.022
2.500	.022
3.000	.022

Note 1) Exercise due caution as chips scatter easily.
 Note 2) Use compressed air to eliminate chips (or coolant for when machining aluminum alloy).

Application Examples

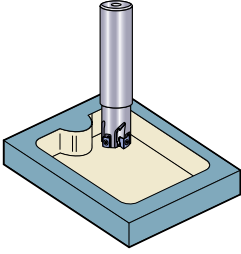
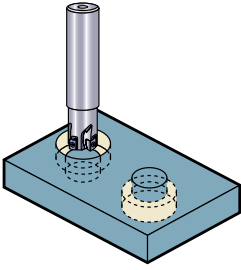
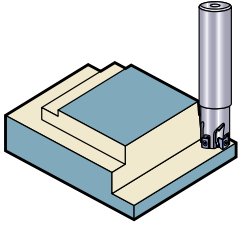
Holder	VPX200R2503SA25S	VPX200R1602SA16S	VPX200R1602SA16S
Insert (Grade)	LOGU0904080PNER-M(MP6120)	LOGU0904080PNER-M(MP6130)	LOGU0904080PNER-M(MP7130)
Workpiece	AISI 1045 	JIS SS400 	JIS SS400+Stainless Steel 
Component	Chucked Parts	Machined Parts	Machined Parts
Cutting Conditions	Cutting Speed (SFM)	490	655
	Feed per Tooth (IPT)	.0043	.0039
	Depth of Cut (inch)	ap = .177 , ae = .984 Max.	ap = .167
Cutting Mode	Dry Cutting	Wet Cutting	Wet Cutting
Results	Compared with conventional product with varying insert tool life due to breakage, VPX has a stable insert tool life that allows for 1.7X more machining.	Solves the problem of easily damaged clamp screws for conventional product, ensuring an excellent finish.	The number of machining has achieved more than 3X the tool life of the conventional product caused by the defect, and the finished surface is also improved.

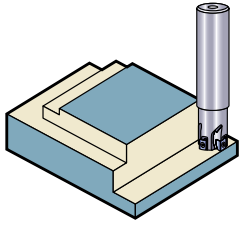
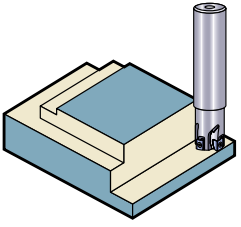
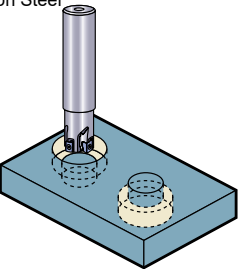
Holder	VPX200R2003SA20S	VPX200R2504SA25S	VPX200R2504SA25S
Insert (Grade)	LOGU0904080PNER-M(MP6120)	LOGU0904080PNER-M(MP6120)	LOGU0904080PNER-M(MP6120)
Workpiece	20MnCr5(Alloy Steel) 	Cast Iron 	Carbon Steel 
Component	Machined Parts	Automotive Components	Machined Parts
Cutting Conditions	Cutting Speed (SFM)	575	335
	Feed per Tooth (IPT)	.0070	.0068
	Depth of Cut (inch)	ap = .079	ap = .118
Cutting Mode	Dry Cutting	Dry Cutting	Wet Cutting
Results	Conventional product has achieved machining times of 330 min before breaking, whereas VPX can maintain sustained machining for over 400 mins.	It is capable of cutting speeds of 655 SFM compared to 560 SFM for conventional product, increasing machining efficiency. Good machining accuracy makes possible stable machining.	VPX has less load on its main shaft than conventional product, achieving more than 3X as much machining. It also has excellent clamp rigidity compared to other conventional product suppressing clamp screw breakage.

The examples shown are actual applications and can differ from the recommended cutting conditions.

* See Index on page 4 for table icon reference. (●, ★, □)

Application Examples

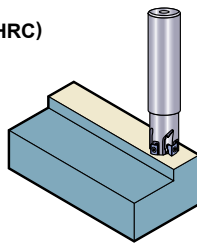
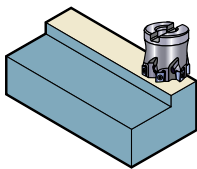
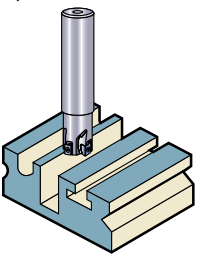
Holder	VPX200R3004SA25S	VPX200-050A05AR	VPX200R2503SA25S	
Insert (Grade)	LOGU0904080PNER-M(MP9130)	LOGU0904040PNER-M(VP15TF)	LOGU0904080PNER-M(MP6120)	
Workpiece	Precipitation Hardening Stainless Steel (38-43HRC) 	AISI 60-40-18 	JIS SS400, AISI 1050 	
Component	Machined Parts	Parts	Machined Parts	
Cutting Conditions	Cutting Speed (SFM)	130	1130	385
	Feed per Tooth (IPT)	.0024	.0055	.0063
	Depth of Cut (inch)	ap = .071	ap = .079— .118 , ae = 1.575	ap = .236
Cutting Mode	Dry Cutting	Wet Cutting	Dry Cutting	
Results	Good sharpness compared to conventional product allows VPX to achieve 2X their insert tool life.	Conventional product can only be used for roughing, but VPX can be used for finishing as well, eliminating processing steps.	VPX achieves better chip evacuation and better surface finish compared to conventional product, better insert tool life.	

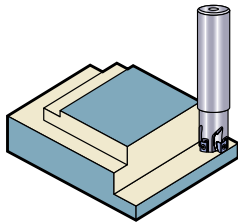
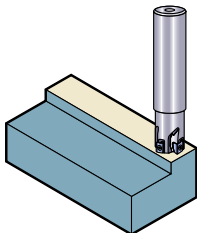
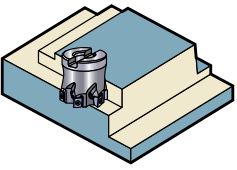
Holder	VPX200R2503SA25S	VPX300R4004SA32S	VPX300-080A10AR	
Insert (Grade)	LOGU0904040PNER-M(MP7130)	LOGU1207080PNER-M(MP6120)	LOGU1207080PNER-M(MP6120)	
Workpiece	AISI 304 	AISI 4140 	Alloy Tool Steel 	
Component	Machined Parts	Center Block	Machined Parts	
Cutting Conditions	Cutting Speed (SFM)	590	490	740
	Feed per Tooth (IPT)	.0236	.0059	.0051
	Depth of Cut (inch)	ap = .106	ap = .197	ap = .197 , ae = 2.756
Cutting Mode	—	Dry Cutting	—	
Results	Less cutting noise than conventional product, allowing cutting conditions to be improved. Also, insert tool life has been lengthened when using the same inserts to machine AISI 1045.	Compared to conventional product, less vibration and good wall surface finish, achieving more than 3X insert tool life.	The number of machining has achieved 2.7X the tool life of the conventional product caused by finish degradation.	

The examples shown are actual applications and can differ from the recommended cutting conditions.

Application Examples

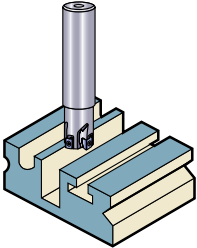
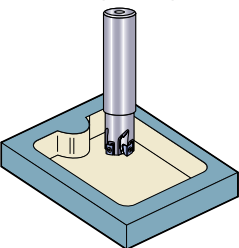
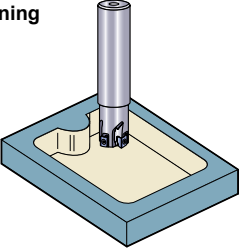
Holder	VPX300R4004SA32S	VPX300R2502SA25S	VPX200R2504SA25S	
Insert (Grade)	LOGU1207080PNER-M(MP6120)	LOGU1207080PNER-M(VP15TF)	LOGU0904080PNER-M(MP6120)	
Workpiece	13CrMo4-5 	Alloy Tool Steel (55HRC) 	AISI 1049 Hardening 	
Component	Machined Parts	Dies	Dies	
Cutting Conditions	Cutting Speed (SFM)	525 → 590	230	655
	Feed per Tooth (IPT)	.0047 → .0059	.0031	.0059
	Depth of Cut (inch)	ap = .118 → .165 , ae = 1.575	ap = .197 , ae = .738	ap = .118
Cutting Mode	Wet Cutting	Dry Cutting	Dry Cutting	
Results	Achieves 2X the insert tool life of conventional product, even when changing to high efficiency conditions.	When machining hardened steel, it achieves 2X the machining of conventional product whose insert tool life is limited by defects.	There is no seating flattening or deformation even when machining for 2500 minutes. And the number of tools has been reduced by increasing corner count to four.	

The examples shown are actual applications and can differ from the recommended cutting conditions.

NEW PRODUCT

WJX SERIES

Double-sided Insert Type High
Feed Radius Milling Cutter
improved sharpness & stability

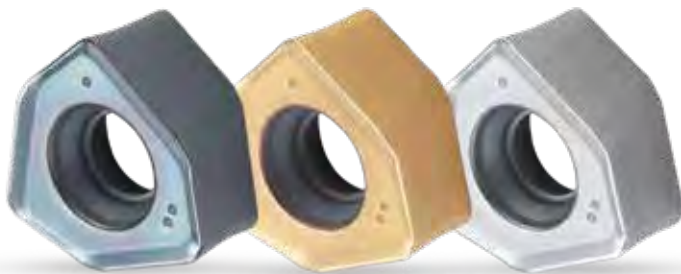

DIA  **EDGE**

WJX Series

High feed radius milling cutter, with stronger double-sided insert type. Experiences low cutting resistance on start up, maintains stable machining even during interrupted machining and large depth of cut.



B235A

Reliable Milling Cutter even in High Efficiency Machining

Covers both high feed and large depth of cut, for high efficiency machining.
 Economical double-sided insert provides the capability for multi-functionality.
 Provides excellent sharpness and gives a long tool life, reducing cutting noise.
 The WJX series was developed for creating reliable and economical tools even in high efficiency machining.

Unconventional Cutting Edge Design for Stable Milling

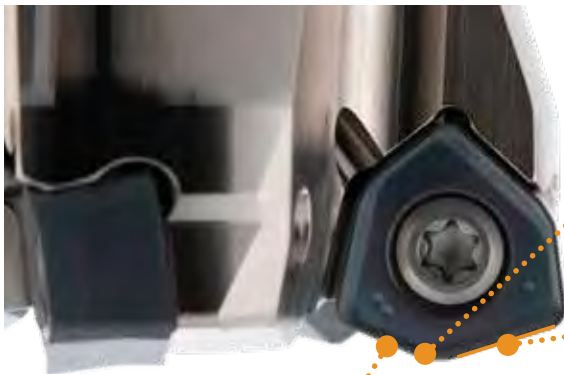

Wiper Cutting Edge

The wiper edge offers good surface finishes sufficient for rough machining.

Straight Cutting Edge

The straight cutting edge extending to the maximum depth of cut (APMX) allows for high feed machining even at large depths of cut.

Minor Cutting Edge

Stable chip formation is possible with the straight cutting edge even at high ramping angle.

Highly-reliable Clamping System

The dovetail structure prevents the insert from floating and gives stable clamping without using a clamp bridge.

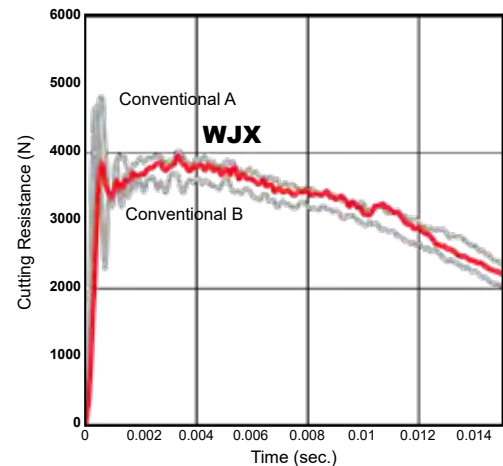
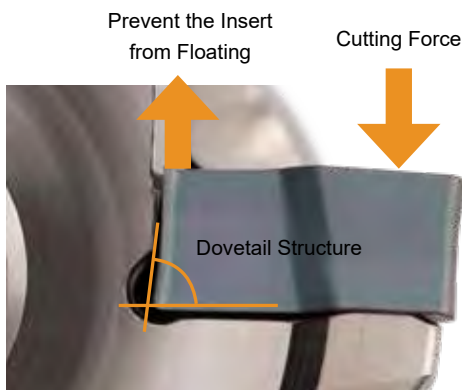

Workpiece Material : AISI 4140
 Cutter Dia. : DCX=ø2.48"
 Cutting Speed : vc=490 SFM
 Feed per Tooth : fz=.059 IPT
 Depth of Cut : ap=.059"
 Width of Cut : ae=1.24"
 Cutting Mode : Single Insert

WJX produces low cutting resistance when entering the cut.



* See Index on page 4 for table icon reference. (●, ★, □)

Complex Shape Flank Face Suitable for Ramping

The flank shape combines the strength and economy of negative inserts, with the sharpness and multi-functionality of positive inserts.



Single-sided : Positive Insert
Ramping Performance
Sharpness



Double-sided : Negative Insert
Cost Efficiency
Insert Strength
Fracture Resistance

Different Types of Milling Cover a Wide Variety of Situations

- ① Ramping
- ② Shoulder Milling
- ③ Pocket Milling
- ④ Helical Milling
- ⑤ Face Milling

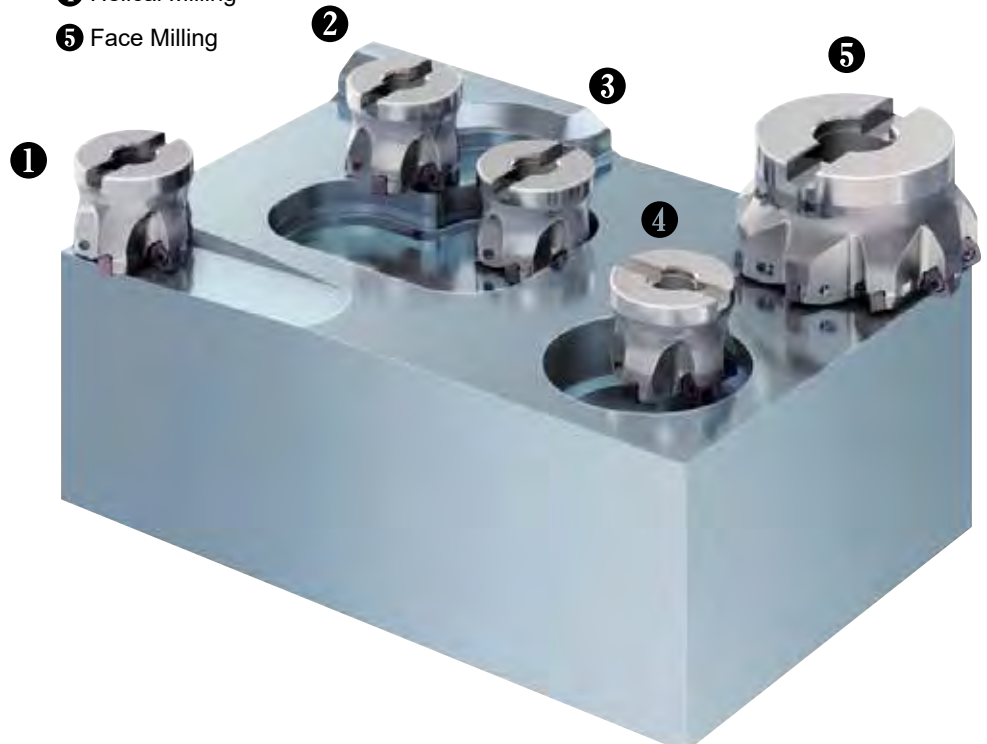

High Strength Insert with Increased Insert Thickness

Increased thickness prevents the inserts from fracturing and makes the cutter body resistant to breakage.

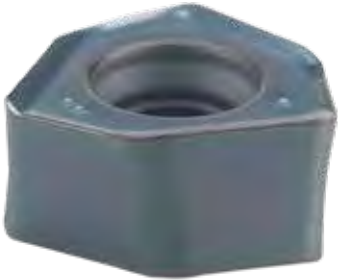

WJX



Cutting Length
15.748 feet



Conventional



Cutting Length
11.811 feet

<Cutting Conditions>
 Workpiece Material : AISI 4140
 Cutter Dia. : DCX=ø2.48"
 Cutting Speed : vc=490 SFM
 Feed per Tooth : fz=.079 IPT
 Depth of Cut : ap=.079"
 Width of Cut : ae=1.772"
 Cutting Mode : Dry Cutting
 Single Insert

Good Chip Formation

The cutting edge forms short chips that prevent the cutter body from chip jamming and tangling as well as allowing for easy cleaning inside of machine tools.



WJX



Conventional

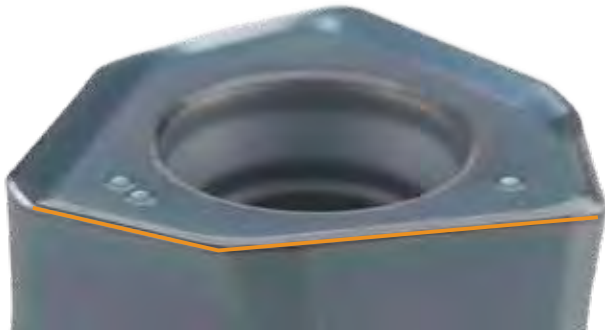

<Cutting Conditions>
 Workpiece Material : AISI 4140
 Cutter Dia. : DCX=ø2.48"
 Cutting Speed : vc=490 SFM
 Feed per Tooth : fz=.079 IPT
 Depth of Cut : ap=.079"
 Width of Cut : ae=1.772"
 Cutting Mode : Dry Cutting
 Single Insert



* See Index on page 4 for table icon reference. (●, ★, □)

MP6100/MP7100/MP9100 Grades TOUGH-Σ Technology

A fusion of the separate coating technologies; PVD and multi-layering provides extra toughness.

Base Layer High Al-(Al, Ti)N

The new technology Al-(Al, Ti)N coating provides stabilisation of the high hardness phase and succeeds in dramatically improving wear, crater and welding resistance.

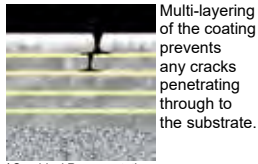

*Graphical Representation.

Al-Ti-Cr-N Based PVD Coating

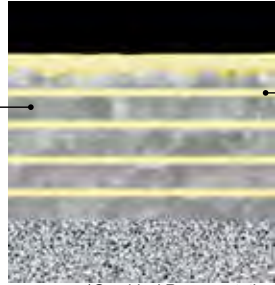

*Graphical Representation.

Best Layer of Each Workpiece Material

P 	(Al,Cr)N Tough! Thermal Cracks	 Thermal Cracks
M 	TiN Tough! Notching	 Notching
S 	CrN Tough! Resistant Chipping	 Welding by Chipping

VP15TF

Stable machining properties are enabled when the coating is combined with a high wear and fracture resistant carbide substrate.

VP30RT

Ideal for heavy interrupted cutting of stainless and general steels because of the excellent fracture resistance properties.

CVD Coated Grade for Milling of Steels and Stainless Steels

MC7020 NEW

MC7020 suppresses crater wear which occurs in high speed cutting, and achieves stable processing in high efficiency machining.

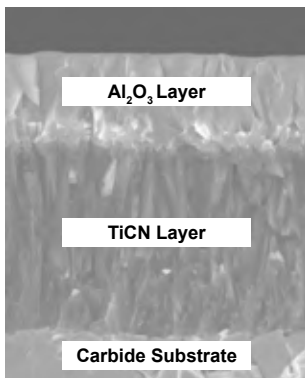

Structure of MC7020

Improved Wear Resistance

The micro-grain wear resistant Al_2O_3 and fibrous TiCN layers deliver excellent wear resistance in high speed cutting.

Improved Fracture Resistance

Use of a specially developed cemented carbide that provides superior resistance to fracture and thermal cracking prevents the cutting edge from sudden fracturing.

Reduced Abnormal Damage

An extremely smooth black super-smooth coating prevents abnormal damage such as chip welding.

Comparison of Coating Surface

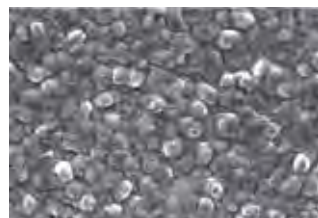

Conventional Coating



All Black Super-smooth Coating

All Black Super-smooth Coating

This smooth outer layer helps to prevent chip welding.

Insert Grades for a Wide Range of Materials

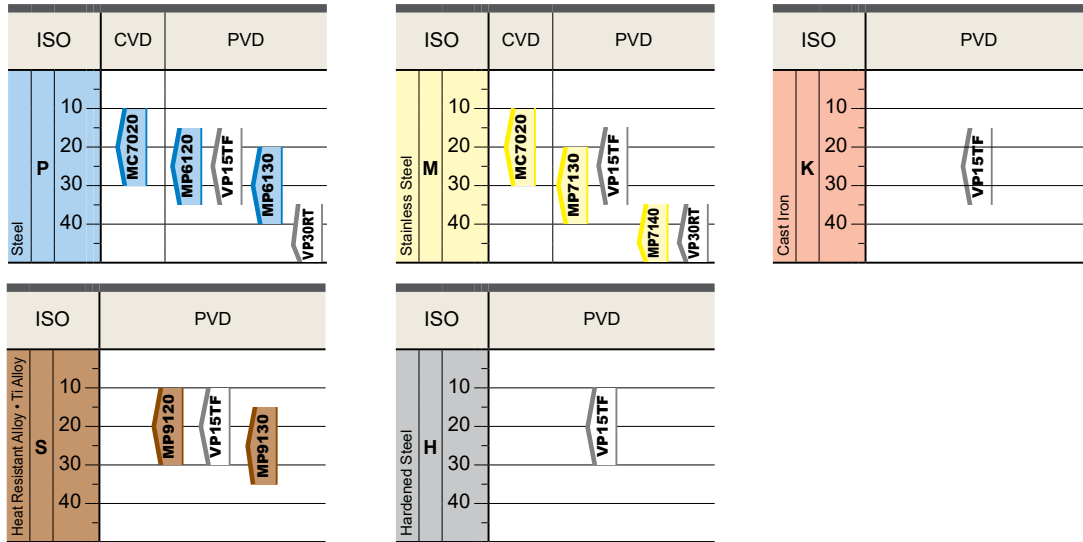

Cutting Performance

AISI 4140 Wear Resistance Comparison

MC7020 has excellent crater wear resistance in high speed cutting.

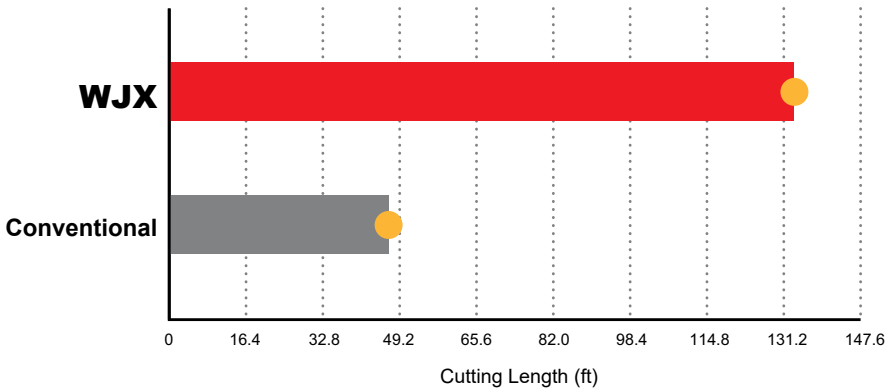

<Cutting Conditions>

Workpiece Material : AISI 4140
 Cutter Dia. : DCX=ø2.48"
 Inserts : JOMU140715ZZER-M
 Grade : MC7020
 Cutting Speed : vc=755 SFM
 Feed per Tooth : fz=.059 IPT
 Depth of Cut : ap=.059"
 Width of Cut : ae=1.772"
 Cutting Mode : Dry Cutting
 Single Insert



WJX
133.9 feet



Conventional
47.2 feet

AISI 4140 Cutting Resistance Comparison

WJX reduces the spindle load for low cutting resistance.

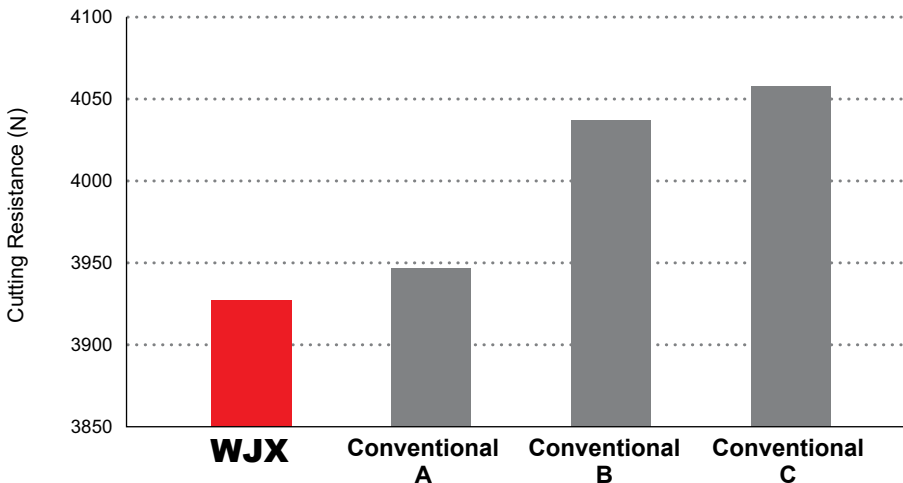

<Cutting Conditions>

Workpiece Material : AISI 4140
 Cutter Dia. : DCX=ø2.48"
 Inserts : JOMU140715ZZER-M
 Grade : VP15TF
 Cutting Speed : vc=490 SFM
 Feed per Tooth : fz=.039 IPT
 Depth of Cut : ap=.079"
 Width of Cut : ae=1.772"
 Cutting Mode : Dry Cutting
 Single Insert



* See Index on page 4 for table icon reference. (●, ★, □)

(Inch)

MULTI-FUNCTIONAL MILLING



Fig.1

ø2.500
ø3.000
ø4.000

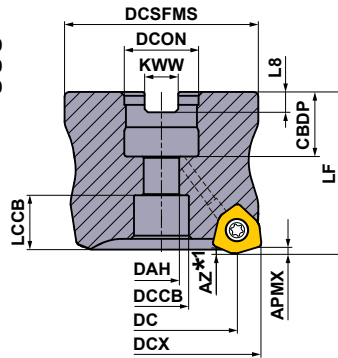
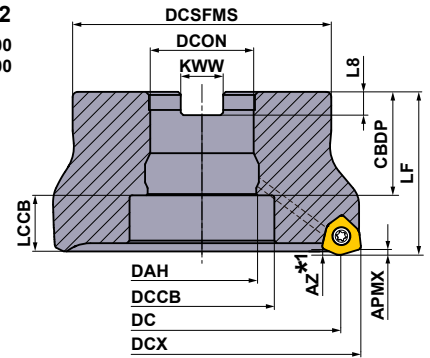

Fig.2

ø5.000
ø6.000



Right hand tool holder only.

Arbor Type

With Coolant Hole

GAMP: -6° T: +13°
GAMF: -10° I: +7°

DCX = inch size, DCON = inch size

(inch)

DCX	Order Number	Stock R	*2 No.T	DC	LF	DCON	WT (lbs)	APMX	RMPX	RPMX (min ⁻¹)	Fig.
2.500	WJX14UR2.5005CA	●	5	1.887	2.000	1.000	1.5	.079	3°	18100	1
3.000	WJX14UR3.0005CA	●	5	2.387	2.000	1.000	2.3	.079	2.2°	16100	1
3.000	WJX14UR3.0006CA	●	6	2.387	2.000	1.000	2.3	.079	2.2°	16100	1
3.000	WJX14UR3.0005DA	●	5	2.387	2.500	1.250	2.7	.079	2.2°	16100	1
3.000	WJX14UR3.0006DA	●	6	2.387	2.500	1.250	2.7	.079	2.2°	16100	1
4.000	WJX14UR4.0006EA	●	6	3.386	2.500	1.500	5.4	.079	1.5°	13300	1
4.000	WJX14UR4.0007EA	●	7	3.386	2.500	1.500	5.5	.079	1.5°	13300	1
5.000	WJX14UR5.0007EA	●	7	4.386	2.500	1.500	7.0	.079	1.1°	11500	2
5.000	WJX14UR5.0009EA	●	9	4.386	2.500	1.500	7.0	.079	1.1°	11500	2
6.000	WJX14UR6.0009FA	●	9	5.386	2.500	2.000	10.3	.079	0.9°	9900	2

*1 Refer to page 16, for the maximum drilling depth (AZ).

*2 Number of Teeth

Note 1) The maximum spindle speeds RPMX are set to ensure tool and insert stability.

Note 2) When using the tool at high spindle speeds, ensure that the tool and arbor are correctly balanced.

CUTTING CONDITIONS > P163-166

(inch)



DCX	DCON	Set Bolt	Geometry
ø2.500", ø3.000"	ø1.000"	HSCU50014H	
ø3.000"	ø1.250"	HSCU62516H	
ø4.000"	ø1.500"	HSCU75016H	
ø5.000"	ø1.500"	MBAU75016H	
ø6.000"	ø2.000"	MBAU100016H	

MULTI-FUNCTIONAL MILLING

(Inch)

Spare Parts

(inch)

Tool Holder Type	*			
		Clamp Screw	Wrench (Insert)	Anti-seize Lubricant
WJX14		TS5R	TKY20T	MK1KS

* Clamp Torque (lbf-in) : TS5R = 44

Mounting Dimensions

(inch)

DCX	Order Number	DCON	CBDP	DAH	DCCB	LCCB	DCSFMS	KWW	L8	Fig.
2.500	WJX14UR2.5004CA	1.000	.945	.539	.787	.689	2.375	.375	.219	1
2.500	WJX14UR2.5005CA	1.000	.945	.539	.787	.689	2.375	.375	.219	1
3.000	WJX14UR3.0005CA	1.000	.945	.539	.787	.689	2.750	.375	.219	1
3.000	WJX14UR3.0006CA	1.000	.945	.539	.787	.689	2.750	.375	.219	1
3.000	WJX14UR3.0005DA	1.250	1.260	.669	1.024	.874	2.875	.500	.281	1
3.000	WJX14UR3.0006DA	1.250	1.260	.669	1.024	.874	2.875	.500	.281	1
4.000	WJX14UR4.0006EA	1.500	1.181	.787	1.181	.953	3.813	.625	.375	1
4.000	WJX14UR4.0007EA	1.500	1.181	.787	1.181	.953	3.813	.625	.375	1
5.000	WJX14UR5.0007EA	1.500	1.654	1.575	2.205	.795	3.813	.625	.375	2
5.000	WJX14UR5.0009EA	1.500	1.654	1.575	2.205	.795	3.813	.625	.375	2
6.000	WJX14UR6.0009FA	2.000	1.693	2.087	3.228	.756	4.875	.750	.437	2

Cutter Diameter and Flat Surface Milling

The maximum cutting diameter (DCX) shown in the WJX items table is not the same as the possible dimensions for plane cutting. The possible dimensions for plane cutting are given as the cutting axle DC value. Please note that this is smaller than the DCX value.

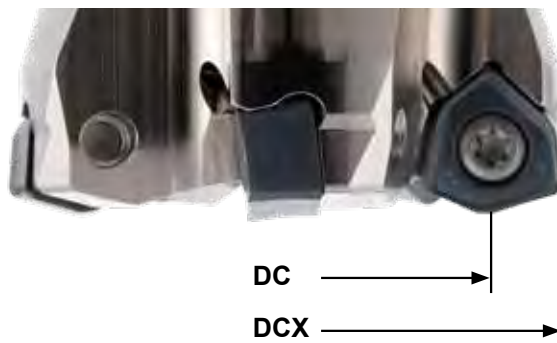

(Metric)

MULTI-FUNCTIONAL MILLING



Fig.1
ø63
ø66
ø80
ø100

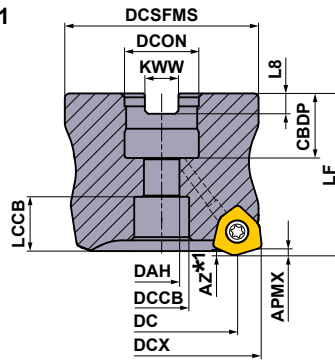
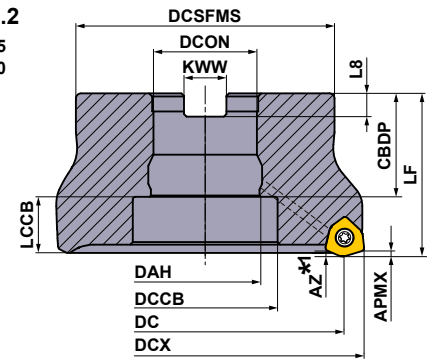

Fig.2
ø125
ø160



Right hand tool holder only.

Arbor Type

With Coolant Hole

GAMP: -6° T: +13°
GAMF: -10° I: +7°

DCX = mm size, DCON = inch size, DCON = mm size

DCX	Order Number	Stock R	*2 No.T	DC	LF	DCON	WT (kg)	APMX	RMPX	RPMX (min ⁻¹)	Fig.
63	WJX14-063A05AR	★	5	47.5	50	22	0.7	2	3°	18200	1
63	WJX14R06304BA	★	4	47.5	50	22.225	0.7	2	3°	18200	1
63	WJX14R06305BA	★	5	47.5	50	22.225	0.7	2	3°	18200	1
63	WJX14-063X05AR	★	5	47.5	50	27	0.6	2	3°	18200	1
66	WJX14-066X05AR	★	5	50.4	50	27	0.7	2	2.8°	17700	1
80	WJX14-080A05AR	★	5	64.4	50	27	1.2	2	2.1°	15600	1
80	WJX14-080A06AR	★	6	64.4	50	27	1.2	2	2.1°	15600	1
80	WJX14R08005DA	★	5	64.4	63	31.75	1.4	2	2.1°	15600	1
80	WJX14R08006DA	★	6	64.4	63	31.75	1.4	2	2.1°	15600	1
100	WJX14R10006DA	★	6	84.4	63	31.75	2.5	2	1.5°	13500	1
100	WJX14R10007DA	★	7	84.4	63	31.75	2.5	2	1.5°	13500	1
100	WJX14-100A06AR	★	6	84.4	63	32	2.5	2	1.5°	13500	1
100	WJX14-100A07AR	★	7	84.4	63	32	2.5	2	1.5°	13500	1
125	WJX14R12507EA	★	7	109.4	63	38.1	3.2	2	1.2°	11600	2
125	WJX14R12509EA	★	9	109.4	63	38.1	3.1	2	1.2°	11600	2
125	WJX14-125B07AR	★	7	109.4	63	40	3.2	2	1.2°	11600	2
125	WJX14-125B09AR	★	9	109.4	63	40	3.1	2	1.2°	11600	2
160	WJX14-160B09AR	★	9	144.4	63	40	4.9	2	0.8°	9900	2
160	WJX14R16009FA	★	9	144.4	63	50.8	4.5	2	0.8°	9900	2

*1 Refer to page 165, for the maximum drilling depth (AZ).

*2 Number of Teeth

CUTTING CONDITIONS > P163-166

Note 1) The maximum spindle speeds RPMX are set to ensure tool and insert stability.

Note 2) When using the tool at high spindle speeds, ensure that the tool and arbor are correctly balanced.

Milling Tool
Inserts



DCX		Set Bolt	Geometry
DCON inch size	DCON mm size		
ø63	ø63(22)	HSC10030H	
	ø63(27), ø66, ø80	HSC12035H	
ø80, ø100	ø100	HSC16040H	
ø125	ø125, ø160	MBA20040H	
ø160		MBA24045H	

MULTI-FUNCTIONAL MILLING

(Metric)

Spare Parts

(mm)

Tool Holder Type	*		
		Wrench (Insert)	Anti-seize Lubricant
WJX14	TS5R	TKY20T	MK1KS

* Clamp Torque (lbf-in) : TS5R = 44

Mounting Dimensions

(mm)

DCX	Order Number	D CON	CB DP	DA H	DCC B	LCC B	DCSFMS	KWW	L8	Fig.
63	WJX14-063A04AR	22	20	11	17	16.7	60	10.4	6.3	1
63	WJX14-063A05AR	22	20	11	17	16.7	60	10.4	6.3	1
63	WJX14R06304BA	22.225	19	11	17	17.7	60	8.4	5	1
63	WJX14R06305BA	22.225	19	11	17	17.7	60	8.4	5	1
63	WJX14-063X05AR	27	23	13	20	15.7	60	12.4	7	1
66	WJX14-066X05AR	27	23	13	20	15.7	60	12.4	7	1
80	WJX14-080A05AR	27	23	13	20	15.7	76	12.4	7	1
80	WJX14-080A06AR	27	23	13	20	15.7	76	12.4	7	1
80	WJX14R08005DA	31.75	32	17	26	19.7	76	12.7	8	1
80	WJX14R08006DA	31.75	32	17	26	19.7	76	12.7	8	1
100	WJX14R10006DA	31.75	32	17	26	19.7	96	12.7	8	1
100	WJX14R10007DA	31.75	32	17	26	19.7	96	12.7	8	1
100	WJX14-100A06AR	32	26	17	26	25.7	96	14.4	8	1
100	WJX14-100A07AR	32	26	17	26	25.7	96	14.4	8	1
125	WJX14R12507EA	38.1	40	40	56	21.7	100	15.9	10	2
125	WJX14R12509EA	38.1	40	40	56	21.7	100	15.9	10	2
125	WJX14-125B07AR	40	40	42	56	21.7	100	16.4	9	2
125	WJX14-125B09AR	40	40	42	56	21.7	100	16.4	9	2
160	WJX14-160B09AR	40	40	42	56	21.7	100	16.4	9	2
160	WJX14R16009FA	50.8	43	53	72	18.7	100	19.1	11	2

Cutter Diameter and Flat Surface Milling

The maximum cutting diameter (DCX) shown in the WJX items table is not the same as the possible dimensions for plane cutting. The possible dimensions for plane cutting are given as the cutting axle DC value. Please note that this is smaller than the DCX value.



* See Index on page 4 for table icon reference. (●, ★, □)

WJX SERIES

P M K S H

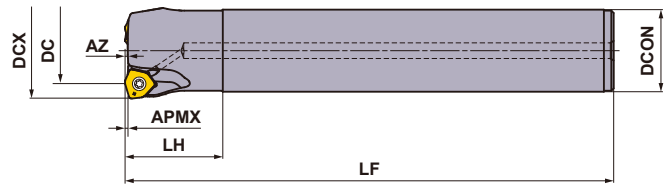

Right hand tool holder only.

Shank Type

With Coolant Hole

(mm)

DCX	Order Number	Stock	* No.T	DC	LF	LH	DCON	APMX	RMPX	RPMX (min ⁻¹)
		R								
50	WJX14R5003SA42S	★	3	34.5	150	50	42	2	4.4°	21200
50	WJX14R5003SA42L	★	3	34.5	250	50	42	2	4.4°	21200



Note 1) The maximum spindle speeds RPMX are set to ensure tool and insert stability.

Note 2) When using the tool at high spindle speeds, ensure that the tool and arbor are correctly balanced.

CUTTING CONDITIONS > P163-166

* Number of Teeth

Spare Parts

Tool Holder Type			
	Clamp Screw	Wrench (Insert)	Anti-seize Lubricant
WJX14	TS5R	TKY20D	MK1KS

* Clamp Torque (lbf-in) : TS5R = 44

Inserts

(inch)

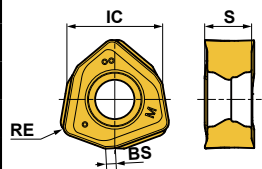
Workpiece Material	P	M	K	S	H	Cutting Conditions (Guide) :								Edge Preparation (Honing) :					
	Steels	Stainless Steels	Cast Irons	Heat Resistant Alloys, Titanium Alloys	Hardened Steels	●	●	✦	●	●	✦	●	●	✦	●	●	✦	E	
Shape	Order Number	Class	Edge Preparation	Coated								IC	S	BS	RE	Geometry			
				MC7020	MP6120	MP6130	MP7130	MP7140	MP9120	MP9130	VP15TF						VP30RT		
	JOMU140715ZZER-M	M	E	●	●	●	●	●	●	●	●	●	●	●	.551	.261	.051	.059	 <p>Right hand insert only.</p>

Milling Tool Inserts

Recommended Cutting Conditions

Correction Value According to Overhang Length

Multiply the recommended cutting conditions on pages 163 and 164 by the corrections factor x overhang length. (inch)

Type	Cutting Dia. Max. DCX	Overhang Length	Correction Value According		
			Cutting Speed vc (SFM)	Depth of Cut ap	Feed fz (IPT)
Shank Type	1.969	< 2.5 × DCON	100%	100%	100%
		3.0 × DCON	90%	100%	90%
		4.0 × DCON	80%	80%	90%
Arbor Type	2.500–3.150	< 2.5 × DCX	100%	100%	100%
		3.0 × DCX	85%	100%	90%
		4.0 × DCX	80%	80%	80%
		5.0 × DCX	75%	75%	60%
	≥ 3.937	6.0 × DCX	70%	70%	40%
		8.0	100%	100%	100%
		12.0	85%	100%	90%
		16.0	80%	80%	80%

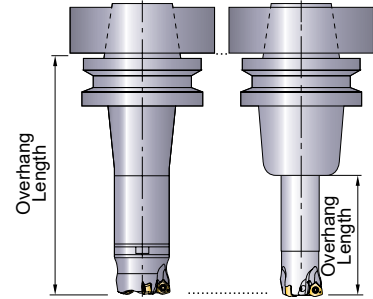

DCON=Connection Dia.

Cutting Speed (Dry Cutting)

(inch)

Workpiece Material	Properties	Cutting Speed vc (SFM)				
P		MP6130	MP6120	MC7020	VP15TF	VP30RT
Mild Steels	≤180HB	460 (295–590)	490 (330–655)	720 (560–885)	490 (330–655)	395 (260–525)
Carbon Steels Alloy Steels	180–280HB	395 (230–590)	460 (260–655)	655 (490–820)	460 (260–655)	330 (195–490)
Carbon Steels Alloy Steels	280–350HB	395 (230–590)	460 (260–655)	655 (490–820)	460 (260–655)	330 (195–490)
Alloy Tool Steels	≤350HB (Annealing)	395 (230–590)	460 (260–655)	655 (490–820)	460 (260–655)	330 (195–490)
Pre-hardened Steels	35–45HRC	295 (165–425)	360 (230–490)	—	360 (230–490)	260 (130–395)
M		MP7130	MP7140	MC7020	VP30RT	
Austenitic Stainless Steels	≤200HB	525 (425–655)	490 (395–590)	720 (560–885)	490 (395–590)	
Austenitic Stainless Steels	>200HB	460 (330–655)	425 (260–590)	620 (460–785)	425 (260–590)	
Ferritic and Martensitic Stainless Steels	≤200HB	490 (330–655)	425 (260–590)	720 (560–885)	425 (260–590)	
Duplex Stainless Steels	≤280HB	425 (260–590)	360 (195–525)	590 (425–755)	360 (195–525)	
Precipitation Hardening Stainless Steels	<450HB	360 (195–525)	295 (165–425)	560 (395–720)	295 (165–425)	
K		VP15TF				
Gray Cast Irons	≤350MPa	525 (395–655)				
Ductile Cast Irons	≤450MPa	490 (330–655)				
Ductile Cast Irons	≤800MPa	395 (260–525)				
S		MP9130	MP9120	VP15TF		
Heat Resistant Alloys	—	100 (65–130)	130 (65–165)	130 (65–165)		
H		VP15TF				
Hardened Steels	40–55HRC	230 (130–330)				

Note 1) To discharge chips effectively, use an air blow when machining. When the air blow is less effective at discharging chips, we recommend wet cutting.
 Note 2) When wet cutting, tool life may become shorter than dry cutting. When carrying out wet cutting for the applications recommended with dry cutting, reduce the cutting speed by 25%.
 Note 3) When large vibration occurs, reduce the cutting conditions.
 Note 4) For interrupted cutting, reduce the cutting speed and feed rate by 20%.

* See Index on page 4 for table icon reference. (●, ★, □)

Depth of Cut / Feed per Tooth (inch)

Workpiece Material	Properties	Depth of Cut ap	Cutting Dia. Max. DCX=50 mm	Cutting Dia. Max. DCX≥2.500", 63 mm	
			Feed fz (IPT)	Feed fz (IPT)	
P	Mild Steels	≤180HB	≤.040	.059(.024-.098)	.067(.024-.110)
			≤.060	.051(.024-.079)	.059(.024-.098)
			≤.080	.047(.024-.079)	.051(.024-.098)
			≤.100	.031(.012-.059)	.039(.012-.063)
			≤.120	.016(.008-.039)	.020(.008-.047)
	Carbon Steels Alloy Steels	180-280HB	≤.040	.059(.020-.079)	.067(.020-.098)
			≤.060	.047(.020-.067)	.051(.020-.098)
			≤.080	.039(.020-.059)	.047(.020-.079)
			≤.100	.028(.012-.047)	.035(.012-.059)
			≤.120	.012(.008-.031)	.016(.008-.039)
	Carbon Steels Alloy Steels	280-350HB	≤.040	.059(.020-.079)	.067(.020-.098)
			≤.060	.047(.020-.067)	.051(.020-.087)
			≤.080	.039(.020-.059)	.047(.020-.079)
			≤.100	.028(.012-.047)	.035(.012-.059)
			≤.120	.012(.008-.031)	.016(.008-.039)
	Alloy Tool Steels	≤350HB (Annealing)	≤.040	.059(.020-.079)	.067(.020-.098)
			≤.060	.047(.020-.067)	.051(.020-.087)
			≤.080	.039(.020-.059)	.047(.020-.079)
			≤.100	.028(.012-.047)	.035(.012-.059)
			≤.120	.012(.008-.031)	.016(.008-.039)
Pre-hardened Steels	35-45HRC	≤.040	.051(.016-.067)	.059(.016-.079)	
		≤.060	.039(.016-.059)	.047(.016-.059)	
		≤.080	.031(.016-.047)	.039(.016-.051)	
M	Austenitic Stainless Steels	≤200HB	≤.040	.039(.020-.047)	.039(.020-.047)
			≤.060	.039(.020-.039)	.039(.020-.039)
	Austenitic Stainless Steels	>200HB	≤.040	.039(.020-.047)	.039(.020-.047)
			≤.060	.039(.020-.039)	.039(.020-.039)
	Ferritic and Martensitic Stainless Steels	≤200HB	≤.040	.039(.020-.047)	.039(.020-.047)
			≤.060	.039(.020-.039)	.039(.020-.039)
	Duplex Stainless Steels	≤280HB	≤.040	.031(.016-.039)	.031(.016-.039)
			≤.060	.031(.016-.031)	.031(.016-.031)
	Precipitation Hardening Stainless Steels	<450HB	≤.040	.031(.016-.039)	.031(.016-.039)
			≤.060	.031(.016-.031)	.031(.016-.031)
K	Gray Cast Irons	≤350MPa	≤.040	.067(.024-.098)	.071(.024-.110)
			≤.060	.059(.024-.079)	.067(.024-.098)
			≤.080	.051(.024-.079)	.059(.024-.098)
			≤.100	.031(.012-.059)	.039(.012-.063)
			≤.120	.016(.008-.039)	.020(.008-.047)
	Ductile Cast Irons	≤450MPa	≤.040	.059(.020-.079)	.067(.020-.098)
			≤.060	.051(.020-.071)	.059(.020-.079)
			≤.080	.047(.020-.071)	.051(.020-.079)
			≤.100	.028(.012-.047)	.035(.012-.059)
			≤.120	.012(.008-.031)	.016(.008-.039)
	Ductile Cast Irons	≤800MPa	≤.040	.051(.016-.071)	.059(.016-.079)
			≤.060	.047(.016-.059)	.051(.016-.071)
			≤.080	.039(.016-.059)	.047(.016-.071)
			≤.100	.031(.012-.047)	.039(.012-.059)
			≤.120	.016(.008-.031)	.020(.008-.047)
S	Heat Resistant Alloys	-	≤.040	.039(.012-.051)	.039(.012-.051)
			≤.060	.031(.012-.047)	.031(.012-.047)
			≤.080	.028(.012-.047)	.028(.012-.047)
H	Hardened Steels	40-55HRC	≤.040	.031(.012-.047)	.031(.012-.047)
			≤.060	.024(.012-.039)	.024(.012-.039)
			≤.080	.020(.012-.031)	.020(.012-.031)

Note 1) To discharge chips effectively, use an air blow when machining. When the air blow is less effective at discharging chips, we recommend wet cutting.
 Note 2) When large vibration occurs, reduce the cutting conditions.
 Note 3) For interrupted cutting, reduce the cutting speed and feed rate by 20%.
 Note 4) If ap is set at .079" or more, avoid machining on the walls or ramping.

Maximum Capacities by Mode

Ramping

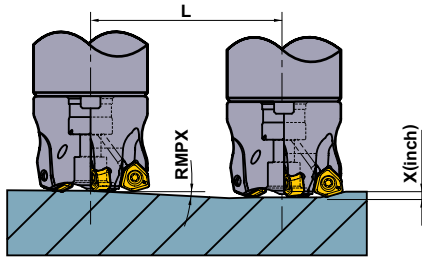

Helical Milling

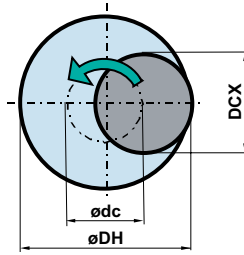

● How to derive a locus of the center of the tool.

$$\text{ødc} = \text{øDH} - \text{DCX}$$

Locus of the Center of the Tool
 Desired Hole Diameter
 Cutting Diameter Maximum

(inch)

Tool Holder Type	DCX	DC	APMX	Ramping			Helical Milling (Blind Hole, Flat Bottom)		Helical Milling (Through Hole)	AZ
				RMPX	L (inch) Required Distance for X inch Depth		DH		DH	
					x = .039	x = .079	Min.	Max.	Min.	
WJX14UR2.500	2.500	1.887	.079	3.0°	.752	1.503	4.283	4.901	3.912	.082
WJX14UR3.000	3.000	2.387	.079	2.2°	1.025	2.050	5.283	5.901	4.909	.082
WJX14UR4.000	4.000	3.386	.079	1.5°	1.504	3.007	7.282	7.901	6.906	.082
WJX14UR5.000	5.000	4.386	.079	1.1°	2.051	4.101	9.281	9.901	8.904	.082
WJX14UR6.000	6.000	5.386	.079	0.9°	2.507	5.013	11.281	11.901	10.903	.082
WJX14R50	1.969	1.358	.079	4.4°	.512	1.024	3.228	3.819	2.874	.082
WJX14-063	2.480	1.870	.079	3.0°	.752	1.504	4.252	4.843	3.898	.082
WJX14R063	2.480	1.870	.079	3.0°	.752	1.504	4.252	4.843	3.898	.082
WJX14-066	2.598	1.984	.079	2.8°	.807	1.610	4.488	5.079	4.134	.082
WJX14-080	3.150	2.535	.079	2.1°	1.075	2.150	5.591	6.181	5.236	.082
WJX14R080	3.150	2.535	.079	2.1°	1.075	2.150	5.591	6.181	5.236	.082
WX14-100	3.937	3.323	.079	1.5°	1.504	3.008	7.165	7.756	6.811	.082
WJX14R100	3.937	3.323	.079	1.5°	1.504	3.008	7.165	7.756	6.811	.082
WJX14-125	4.921	4.307	.079	1.2°	1.882	3.760	9.134	9.724	8.780	.082
WJX14R125	4.921	4.307	.079	1.2°	1.882	3.760	9.134	9.724	8.780	.082
WJX14-160	6.299	5.685	.079	0.8°	2.823	5.642	11.890	12.480	11.535	.082
WJX14R160	6.299	5.685	.079	0.8°	2.823	5.642	11.890	12.480	11.535	.082

DCX = Cutting Dia. Max.

DC = Cutting Dia.

DH = Desired Hole Dia.

APMX = Depth of Cut Max.

RMPX = Ramping Angle Max.

AZ = Plunge Depth Max.

Note 1) When ramping and helical milling, it is recommended to reduce the feed per tooth.

Note 2) When ramping, helical milling and drilling, long continuous chips may be scattered so please be careful.

<Helical Milling>

To obtain a flat bottom surface when helical milling, it requires to remove "the uncut part" in the center of the workpiece material at a final pass.

When helical milling, make sure that the depth of cut per helical pass doesn't exceed the maximum depth of cut (APMX).

<Drilling>

When drilling, set the axial feed per revolution at .008 IPR or less.



Operational Guidance

■ Depth of Cut

The straight cutting edge is .079" at maximum depth of cut (APMX).

When plane cutting steels and cast irons, the depth of cut can be set at up to .118" until you reach the corner radius.

When you exceed .079", you will need to decrease the feed rate. See the cutting conditions on page 15 for reference.

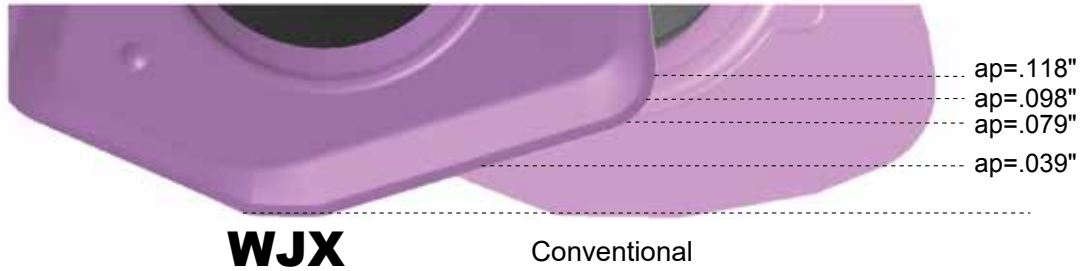

■ Remaining Stock

When using the WJX, please program as a radius cutter.

The approximate remaining stock **K** for the program is shown below.

Also see the table on the right for the remaining stock **H** of the vertical wall.

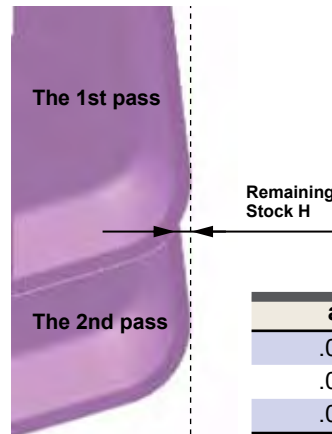
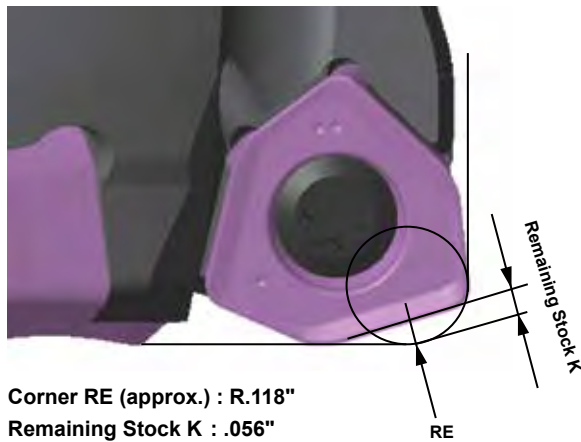

(inch)	
ap	Remaining Stock H
.039	.002
.059	.003
.079	.005



PRODUCT EXTENSION

DIA  **EDGE**

WSX445 SERIES



UNIQUE DOUBLE Z INSERT GEOMETRY
general purpose with low
cutting resistance



Milling Tool
Inserts



Inserts

(inch)

Inserts with Breaker

Work Material	P	Steeels												Cutting Conditions :					
	M	Stainless Steels												●	●	●	●		
	K	Cast Irons												✦	✦	✦	✦		
Work Material	N	Non-ferrous Metals												Edge Preparation (Honing) :					
	S	Heat Resistant Alloys, Titanium Alloys												E	F	F	F		
Work Material	H	Hardened Steels																	
Shape	Order Number	Class	Hand	Edge Preparation	Coated								Cermet	Carbide	IC	S	BS	RE	Geometry
					MC5020	MP6120	MP6130	MP7130	MP7140	MP9120	MP9130	VP15TF	VP20RT	MX3030					
	SNGU140812ANFR-L	G	R	F														●	
	SNGU140812ANER-L	G	R	E	●	●	●	●	●	●	●	●	●	●					
	SNGU140812ANER-M	G	R	E	●	●	●	●	●	●	●	●	●	●					
	SNMU140812ANER-M	M	R	E	●	●	●	●	●	●	●	●	●	●					
	SNMU140812ANER-R	M	R	E	●	●	●					●	●						
	SNMU140812ANER-H	M	R	E	●	●						●	●						
	NEW SNGU140812ANFL-L	G	L	F														●	
	NEW SNGU140812ANEL-L	G	L	E	●	●						●	●						
	SNGU140812ANEL-M	G	L	E	●	●						●	●						
	SNMU140812ANEL-M	M	L	E	●	●						●	●						
	SNMU140812ANEL-R	M	L	E	●	●						●							

Right hand insert shown.

Wiper Inserts

(inch)

Work Material	P	Steeels												Cutting Conditions :			
	M	Stainless Steels												●	●	●	●
	K	Cast Irons												✦	✦	✦	✦
Work Material	S	Heat Resistant Alloys, Titanium Alloys												Edge Preparation (Honing) :			
	H	Hardened Steels												E	F	F	F
Shape	Order Number	Class	Edge Preparation	Coated				Cermet	L	W1	S	BS	RE	Geometry			
				MC5020	MP6120	VP15TF	NEW MX3020										
	WNGU1406ANEN8C-M	G	E	●	●	●	●		.713	.551	.236	.315	.039				

Instructions for Use of Wiper Inserts

- Wiper inserts for WSX445 are two-cornered. Please set as shown in Fig.1.
- Excellent surface finish can be achieved with one wiper.
- Set more than 2 wiper inserts, equally spaced, when the feed per revolution is larger than .315 IPR.



Fig.1



Fig.2

* See Index on page 4 for table icon reference. (●, ★, □)

PRODUCT EXTENSION

DIA  **EDGE**

SIDE CUTTER SERIES



LOW CUTTING RESISTANCE





Milling Tool
Inserts

B242A

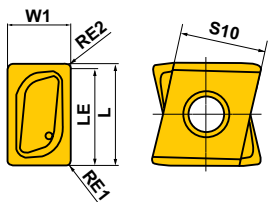
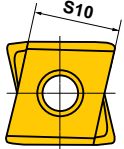

Inserts

(inch)

Shape	Order Number	Hand	Class	Edge Preparation			Coated			L	LE	S	S10	RE1	RE2	W1	Geometry		
				MP6120	VP15TF														
Low Resistance Type M Breaker	LNGU130804PNER-M	R	G	E	●				.512	.480	.315	.433	.016	.031	.315	  			
	LNGU130804PNEL-M	L	G	E	●				.512	.480	.315	.433	.016	.031	.315				
	LNGU130808PNER-M	R	G	E	●				.512	.480	.315	.433	.031	.031	.315				
	LNGU130808PNEL-M	L	G	E	●				.512	.480	.315	.433	.031	.031	.315				
	LNGU130812PNER-M	R	G	E	●				.512	.480	.315	.433	.047	.031	.315				
	LNGU130812PNEL-M	L	G	E	●				.512	.480	.315	.433	.047	.031	.315				
	LNGU130816PNER-M	R	G	E	●				.512	.480	.315	.433	.063	.031	.315				
	LNGU130816PNEL-M	L	G	E	●				.512	.480	.315	.433	.063	.031	.315				
	LNGU130820PNER-M	R	G	E	●				.512	.480	.315	.433	.079	.031	.315				
	LNGU130820PNEL-M	L	G	E	●				.512	.480	.315	.433	.079	.031	.315				
	LNGU130824PNER-M	R	G	E	●				.512	.480	.315	.433	.094	.031	.315				
	LNGU130824PNEL-M	L	G	E	●				.512	.480	.315	.433	.094	.031	.315				
	LNGU130830PNER-M	R	G	E	●				.512	.449	.315	.433	.118	.063	.315				
	LNGU130830PNEL-M	L	G	E	●				.512	.449	.315	.433	.118	.063	.315				
	LNGU130840PNER-M	R	G	E	●				.512	.449	.315	.433	.157	.063	.315				
	LNGU130840PNEL-M	L	G	E	●				.512	.449	.315	.433	.157	.063	.315				
LNGU130850PNER-M	R	G	E	●				.512	.449	.315	.433	.197	.063	.315					
LNGU130850PNEL-M	L	G	E	●				.512	.449	.315	.433	.197	.063	.315					
Strong Cutting Edge Type R Breaker	NEW LNGU130804PNER-R	R	G	E	●	●			.512	.480	.315	.433	.016	.031	.315				
	NEW LNGU130804PNEL-R	L	G	E	●	●			.512	.480	.315	.433	.016	.031	.315				
	NEW LNGU130808PNER-R	R	G	E	●	●			.512	.480	.315	.433	.031	.031	.315				
	NEW LNGU130808PNEL-R	L	G	E	●	●			.512	.480	.315	.433	.031	.031	.315				
	NEW LNGU130812PNER-R	R	G	E	●	●			.512	.480	.315	.433	.047	.031	.315				
	NEW LNGU130812PNEL-R	L	G	E	●	●			.512	.480	.315	.433	.047	.031	.315				
	NEW LNGU130816PNER-R	R	G	E	●	●			.512	.480	.315	.433	.063	.031	.315				
	NEW LNGU130816PNEL-R	L	G	E	●	●			.512	.480	.315	.433	.063	.031	.315				
	NEW LNGU130820PNER-R	R	G	E	●	●			.512	.480	.315	.433	.079	.031	.315				
	NEW LNGU130820PNEL-R	L	G	E	●	●			.512	.480	.315	.433	.079	.031	.315				
	NEW LNGU130824PNER-R	R	G	E	●	●			.512	.480	.315	.433	.094	.031	.315				
	NEW LNGU130824PNEL-R	L	G	E	●	●			.512	.480	.315	.433	.094	.031	.315				
	NEW LNGU130830PNER-R	R	G	E	●	●			.512	.449	.315	.433	.118	.063	.315				
	NEW LNGU130830PNEL-R	L	G	E	●	●			.512	.449	.315	.433	.118	.063	.315				
	NEW LNGU130840PNER-R	R	G	E	●	●			.512	.449	.315	.433	.157	.063	.315				
	NEW LNGU130840PNEL-R	L	G	E	●	●			.512	.449	.315	.433	.157	.063	.315				
NEW LNGU130850PNER-R	R	G	E	●	●			.512	.449	.315	.433	.197	.063	.315					
NEW LNGU130850PNEL-R	L	G	E	●	●			.512	.449	.315	.433	.197	.063	.315					

Right hand insert shown.



* See Index on page 4 for table icon reference. (●, ★, □)

PRODUCT EXTENSION

DIA  **EDGE**

APX 3000/4000



NEW GENERATION
of high performance cutters



Milling Tool
Inserts



DEEP SHOULDER MILLING

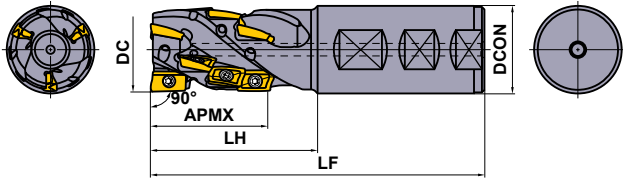

Shank Type (A Holders)

Right hand tool holder only.

RE	Order Number	Stock R	Coolant Hole	*1 No.F	Total	Dimensions (inch)					*2			
						DC	DCON	LF	LH	APMX	Insert Screw	Wrench	Anti-seize Lubricant	Insert Type
.008 .079	APX3KUR121FN12S11A04	●	N	1	4	.750	.750	5.000	1.750	1.102	TPS25	TIP07F	MK1KS	AO-T1236
	APX3KUR162FA16S11A06	●	Y	2	6	1.000	1.000	5.000	1.750	1.102	TPS25-1	TIP07F	MK1KS	
	APX3KUR162FA16M14A08	●	Y	2	8	1.000	1.000	5.250	2.000	1.456	TPS25-1	TIP07F	MK1KS	
	APX3KUR202FA20S14A08	●	Y	2	8	1.250	1.250	5.250	2.000	1.456	TPS25-1	TIP07F	MK1KS	
	APX3KUR202FA20M18A10	●	Y	2	10	1.250	1.250	5.750	2.500	1.811	TPS25-1	TIP07F	MK1KS	
	APX3KUR243FA24S18A15	●	Y	3	15	1.500	1.500	5.750	2.500	1.811	TPS25-1	TIP07F	MK1KS	
	APX3KUR243FA24M21A18	●	Y	3	18	1.500	1.500	6.000	2.750	2.165	TPS25-1	TIP07F	MK1KS	

Y=Yes, N=No *1 Number of Flutes *2 Clamp Torque (lbf-in) : TPS25=8.9, TPS25-1=8.9

Note 1) When using inserts with corner radius RE ≥ .094", machining of the holder is required.

Note 2) Corner radius RE .031" is recommended for the peripheral cutting edges except the bottom cutting edge (end cutting).
Insert RE .008" and .016" can also be used.

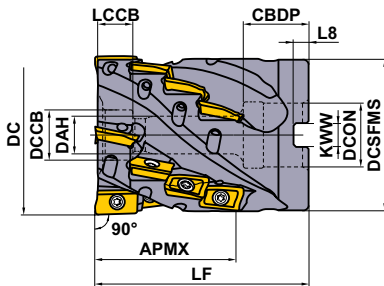

Shell Type (A Holders)

With Coolant Hole

Right hand tool holder only.

RE	Order Number	Stock R	*1 No.F	Total	Dimensions (inch)											*2			
					DC	LF	DCON	CBDB	DAH	DCCB	LCCB	DCSFMS	KWW	L8	APMX	Insert Screw	Wrench	Anti-seize Lubricant	Insert Type
.008 .079	APX3KUR2.0004AA18A20	●	4	20	2.000	2.500	.750	.750	.395	.630	.457	1.936	.313	.187	1.811	TPS25-1	TIP07F	MK1KS	AO-T1236

*1 Number of Flutes *2 Clamp Torque (lbf-in) : TPS25-1 = 8.9

Note 1) When using inserts with corner radius RE ≥ .094", machining of the holder is required.

Note 2) Corner radius RE .031" is recommended for the peripheral cutting edges except the bottom cutting edge (end cutting).

Insert RE .008" and .016" can also be used.

DC	Set Bolt	Geometry
φ2.000"	HSCUF37520	

APX SERIES



APX3000 NEW

Long Edge

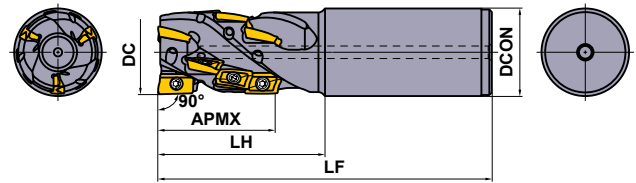

(Metric)

Shank Type (A Holders)

Right hand tool holder only.

RE (inch)	Order Number	Stock	Coolant Hole	No.F	*1 Total	Dimensions (mm)					*2	Wrench	Anti-seize Lubricant	Insert Type
						DC	DCON	LF	LH	APMX				
.008 .079	APX3KR2004SN20S028A	★	N	1	4	20	20	125	45	28	TPS25	TIP07F	MK1KS	AO _T 1236
	APX3KR2506SA25S028A	★	Y	2	6	25	25	125	45	28	TPS25-1	TIP07F	MK1KS	
	APX3KR2508SA25M037A	★	Y	2	8	25	25	130	50	37	TPS25-1	TIP07F	MK1KS	
	APX3KR3208SA32S037A	★	Y	2	8	32	32	130	50	37	TPS25-1	TIP07F	MK1KS	
	APX3KR3210SA32M046A	★	Y	2	10	32	32	140	60	46	TPS25-1	TIP07F	MK1KS	
	APX3KR3212SA32S037A	★	Y	3	12	32	32	130	50	37	TPS25-1	TIP07F	MK1KS	
	APX3KR3215SA32M046A	★	Y	3	15	32	32	140	60	46	TPS25-1	TIP07F	MK1KS	
	APX3KR4015SA42S046A	★	Y	3	15	40	42	140	60	46	TPS25-1	TIP07F	MK1KS	
	APX3KR4018SA42M055A	★	Y	3	18	40	42	150	70	55	TPS25-1	TIP07F	MK1KS	

Y=Yes, N=No *1 Number of Flutes *2 Clamp Torque (lbf-in) : TPS25=8.9, TPS25-1=8.9

Note 1) When using inserts with corner radius RE ≥ .094", machining of the holder is required.

Note 2) Corner radius RE .031" is recommended for the peripheral cutting edges except the bottom cutting edge (end cutting).
Insert RE .008" and .016" can also be used.

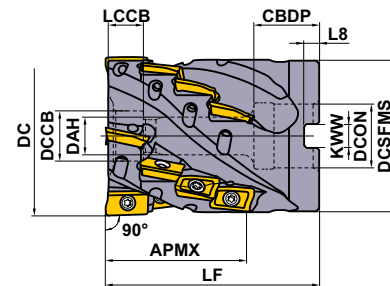

Metric For Metric Arbors

Shell Type (A Holders)

With Coolant Hole

Right hand tool holder only.

RE (inch)	Order Number	Stock	No.F	*1 Total	Dimensions (mm)											*2	Wrench	Anti-seize Lubricant	Insert Type
					DC	LF	DCON	CBDB	DAH	DCCB	LCCB	DCSFMS	KWW	L8	APMX				
.008 .079	APX3K-040A16A037RA	★	4	16	40	50	16	18	9	14	9.9	38.5	8.4	5.6	37	TPS25-1	TIP07F	MK1KS	AO _T 1236
	APX3K-050A20A046RA	★	4	20	50	60	22	20	11	17	11.9	48.4	10.4	6.3	46	TPS25-1	TIP07F	MK1KS	

*1 Number of Flutes *2 Clamp Torque (lbf-in) : TPS25-1 = 8.9

Note 1) When using inserts with corner radius RE ≥ .094", machining of the holder is required.

Note 2) Corner radius RE .031" is recommended for the peripheral cutting edges except the bottom cutting edge (end cutting).

Insert RE .008" and .016" can also be used.

DC	Set Bolt	Geometry
φ40mm	HSC08040	
φ50mm	HSC10045	

The bore diameter (DCON) is equivalent to a metric size.

DRILLING



NEW PRODUCT

DIA  **EDGE**

DLE SERIES



SOLID CARBIDE DRILLS
for centering & chamfering



Solid Carbide Drills for Centering and Chamfering

Leading Drill Series

Completes strict standards for centering and chamfering.

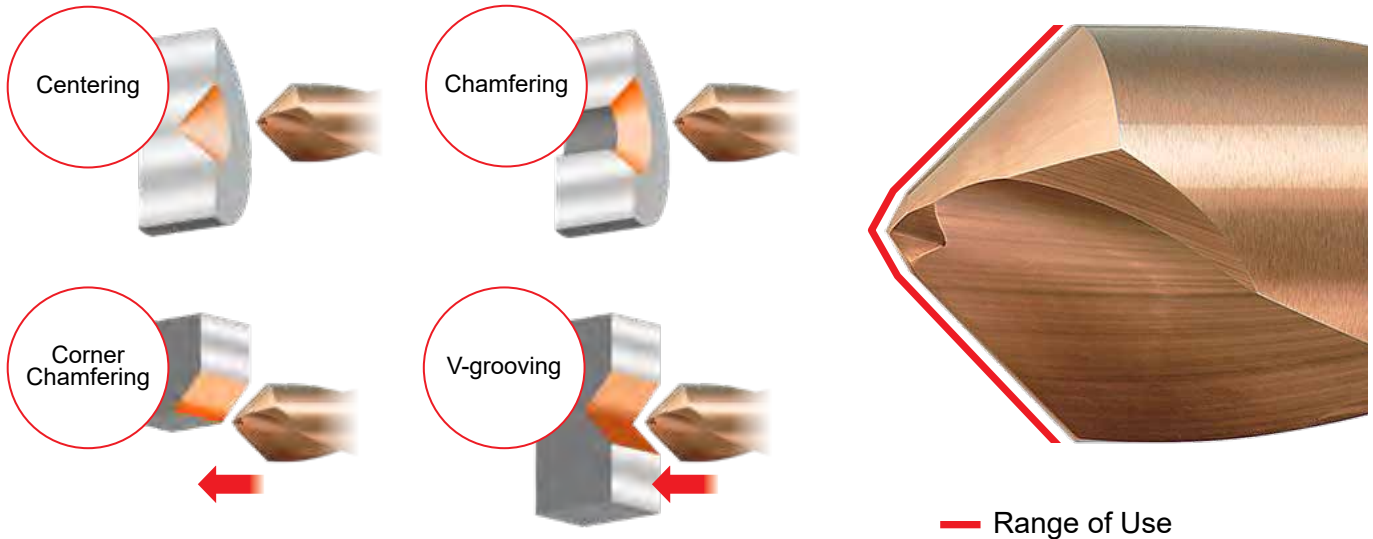

Features

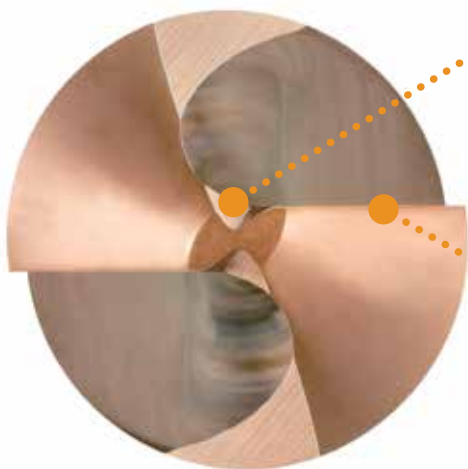

Thinning Geometry

The thinning pocket promotes smooth chip evacuation and provides excellent hole position accuracy. Additionally, the negative cutting edge of the drill point offers high cutting edge strength.

Sharp Cutting Edge and High Fracture Resistance

Sharp cutting edge shape and high fracture resistance, stable cutting and burr prevention are possible.



DLE



Conventional



* See Index on page 4 for table icon reference. (●, ★, □)



Two-step Point Angles

Two-step point angles ensure strength at the center and prevents sudden fracturing.

*The central area will not have a 90° bottom hole angle.

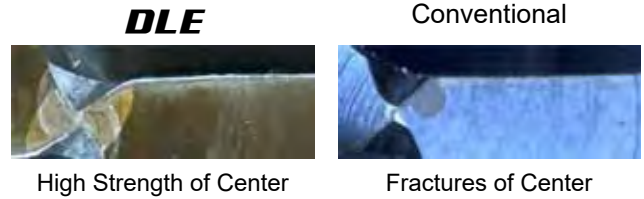

Coated Grade **DP1020**

DP1020 grade offers excellent wear resistance and reduced friction for longer tool life and a versatile range of applications.

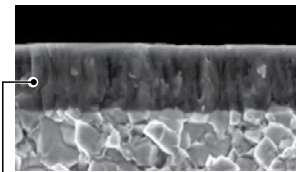

With Accumulated Al-Ti-Cr-N Based PVD Coating

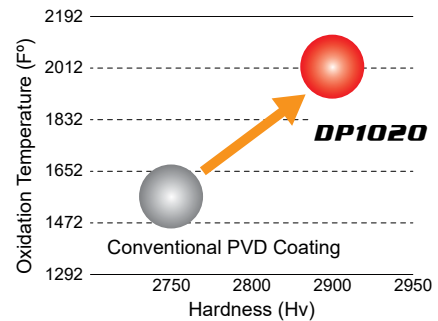

Extensive Support for CNC Automatic Lathes

Diverse lineup of shanks compatible with ER collets.

DCON(Connection Diameter)	.197 inch=ER8
DCON	.276 inch=ER11

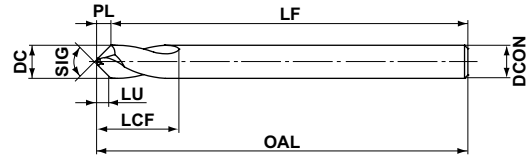

				(mm)			
DCON=3		3 < DCON ≤ 6		6 < DCON ≤ 10		10 < DCON ≤ 16	
0		0		0		0	
-0.010		-0.012		-0.015		-0.018	
				(inch)			
DCON=.1181		.1181 < DCON ≤ .2362		.2362 < DCON ≤ .3937		.3937 < DCON ≤ .6299	
0		0		0		0	
-.0004		-.0005		-.0006		-.0007	

External Coolant

DC		SIG	DP1020	Order Number	LU		LCF		OAL		LF		PL		DCON	
(mm)	(inch)				(mm)	(inch)	(mm)	(inch)	(mm)	(inch)	(mm)	(inch)	(mm)	(inch)	(mm)	(inch)
3.0	.1181	90°	●	DLE0300S030P090	1.2	.047	9	.354	45	1.772	43.7	1.720	1.3	.051	3	.118
4.0	.1575	90°	●	DLE0400S040P090	1.6	.063	12	.472	50	1.969	48.3	1.902	1.7	.067	4	.157
5.0	.1969	90°	●	DLE0500S050P090	2.0	.079	14	.551	60	2.362	57.9	2.280	2.1	.083	5	.197
6.0	.2362	90°	●	DLE0600S060P090	2.4	.094	15	.591	66	2.598	63.4	2.496	2.6	.102	6	.236
7.0	.2756	90°	●	DLE0700S070P090	2.8	.110	18	.709	74	2.913	71.0	2.795	3.0	.118	7	.276
8.0	.3150	90°	●	DLE0800S080P090	3.2	.126	20	.787	74	2.913	70.6	2.780	3.4	.134	8	.315
10.0	.3937	90°	●	DLE1000S100P090	4.1	.161	24	.945	84	3.307	79.7	3.138	4.3	.169	10	.394
12.0	.4724	90°	●	DLE1200S120P090	4.9	.193	28	1.102	95	3.740	89.9	3.539	5.1	.201	12	.472
16.0	.6299	90°	●	DLE1600S160P090	6.6	.260	35	1.378	113	4.449	106.2	4.181	6.8	.268	16	.630

(Note 1) In the region of roughly DC/4, which is the region of the two-step point angles, the central area will not have a 90° bottom hole angle. Chamfering will also not be possible in this region.
 (Note 2) The centering diameter should be less than the drill diameter (processing diameter) DC and the usable length LU should be referred to as a guideline.



Drill Diameter Selection When Chamfering

With respect to guide hole diameter **D**, select the drill diameter (cutting diameter) **DC** to be within the range of $D < DC < 2D$.

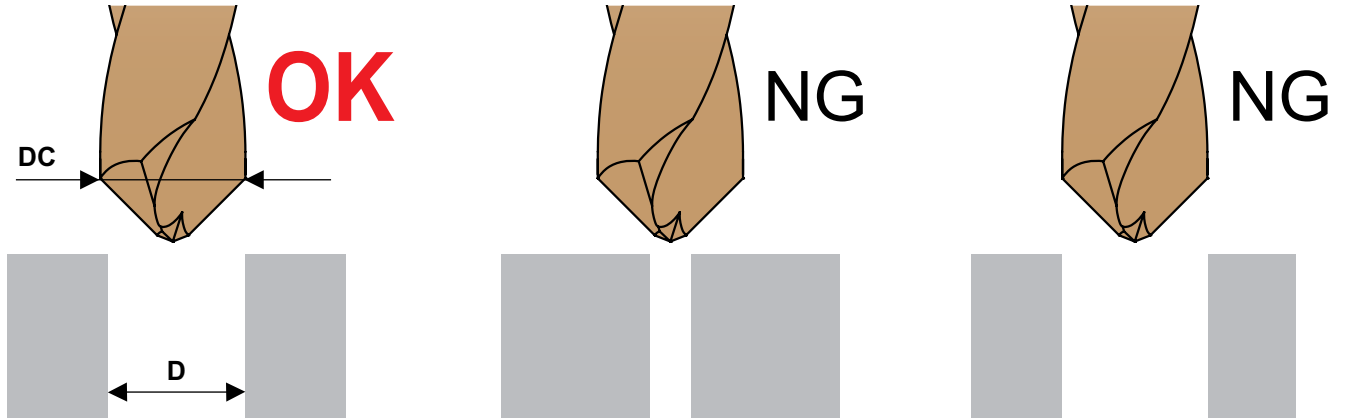

If **DC** is equal to or greater than **2D**:

If **DC** is a drill diameter equal to **D**:

Example) If guide hole diameter **D** is .197":
Drill diameter **DC** should be equal to or greater than .236" but less than .394".
Select a **DC** of .236", .276", or .315".

If drill diameter **DC** is too large compared to guide hole diameter **D** (equal to or greater than **2D**), chamfering cannot be performed.

Chamfering cannot be performed if drill diameter **DC** is the same as guide hole diameter **D**.

When Centering

The tool cannot be used for processing if the centering diameter has the same guide hole diameter as drill diameter **DC**. Refer to the usable length **LU** (page 179) as a guideline.

In the region of roughly $DC/4$, which is the region of the two-step point angles, the central area will not have a 90° bottom hole angle.

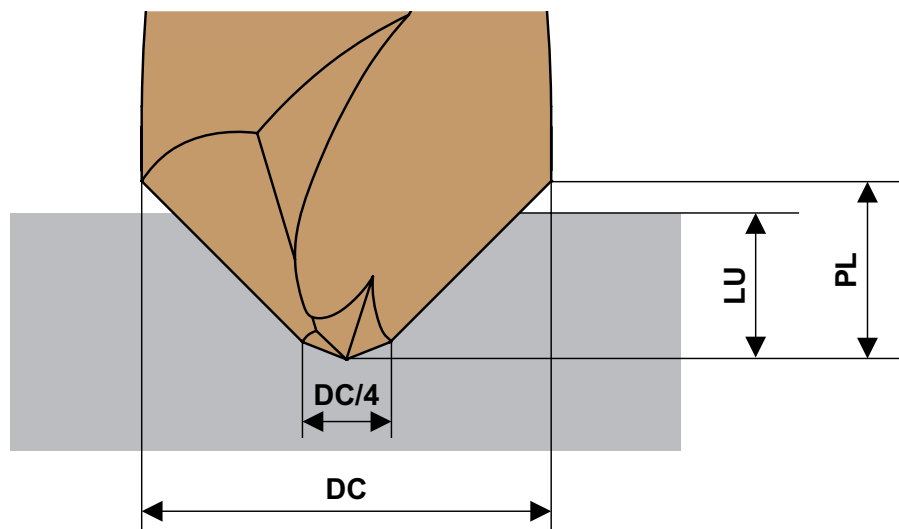

Recommended Cutting Conditions

(inch)

Work Material		Mild Steels ($\leq 180\text{HB}$)		Carbon Steels, Alloy Steels (180–280HB)		Carbon Steels, Alloy Steels (280–350HB)	
		AISI 1010 etc.		AISI 1045, 4140 etc.		AISI 4340 etc.	
DC		Cutting Speed (SFM)	Feed (Min.—Max.) (IPR)	Cutting Speed (SFM)	Feed (Min.—Max.) (IPR)	Cutting Speed (SFM)	Feed (Min.—Max.) (IPR)
(mm)	(inch)						
3	.1181	245	.0024 (.0016—.0031)	210	.0024 (.0016—.0031)	195	.0020 (.0012—.0028)
4	.1575	245	.0024 (.0016—.0031)	210	.0024 (.0016—.0031)	195	.0020 (.0012—.0028)
5	.1969	260	.0028 (.0020—.0035)	230	.0028 (.0020—.0035)	210	.0024 (.0016—.0031)
6	.2362	260	.0028 (.0020—.0035)	230	.0028 (.0020—.0035)	210	.0024 (.0016—.0031)
7	.2756	260	.0031 (.0020—.0039)	230	.0031 (.0020—.0039)	210	.0024 (.0016—.0031)
8	.3150	260	.0031 (.0020—.0039)	230	.0031 (.0020—.0039)	210	.0024 (.0016—.0031)
10	.3937	280	.0035 (.0020—.0043)	245	.0035 (.0020—.0043)	230	.0028 (.0016—.0035)
12	.4724	280	.0035 (.0020—.0043)	245	.0035 (.0020—.0043)	230	.0028 (.0016—.0035)
16	.6299	295	.0047 (.0039—.0055)	260	.0047 (.0039—.0055)	245	.0031 (.0024—.0039)

Work Material		Austenitic Stainless Steels ($\leq 200\text{HB}$)		Gray Cast Irons ($\leq 350\text{MPa}$)		Ductile Cast Irons ($\leq 450\text{MPa}$)	
		AISI 304, 316 etc.		AISI No45B etc.		AISI 60-40-18 etc.	
DC		Cutting Speed (SFM)	Feed (Min.—Max.) (IPR)	Cutting Speed (SFM)	Feed (Min.—Max.) (IPR)	Cutting Speed (SFM)	Feed (Min.—Max.) (IPR)
(mm)	(inch)						
3	.1181	50	.0016 (.0008—.0024)	245	.0024 (.0016—.0031)	180	.0024 (.0016—.0031)
4	.1575	50	.0016 (.0008—.0024)	245	.0024 (.0016—.0031)	180	.0024 (.0016—.0031)
5	.1969	65	.0024 (.0016—.0031)	260	.0028 (.0020—.0035)	195	.0028 (.0020—.0035)
6	.2362	65	.0024 (.0016—.0031)	260	.0028 (.0020—.0035)	195	.0028 (.0020—.0035)
7	.2756	65	.0024 (.0016—.0031)	260	.0031 (.0020—.0039)	195	.0028 (.0020—.0035)
8	.3150	65	.0024 (.0016—.0031)	260	.0031 (.0020—.0039)	195	.0028 (.0020—.0035)
10	.3937	65	.0024 (.0016—.0031)	280	.0035 (.0020—.0043)	195	.0031 (.0020—.0039)
12	.4724	65	.0024 (.0016—.0031)	280	.0035 (.0020—.0043)	195	.0031 (.0020—.0039)
16	.6299	65	.0031 (.0024—.0039)	295	.0047 (.0039—.0055)	195	.0043 (.0035—.0051)

(Note 1) When chamfering a circumference of a guide hole, make sure that the tool diameter(DC) is $D < DC < 2D$.

(Note 2) When V-grooving and chamfering, please reduce cutting conditions.

Operational Guidance

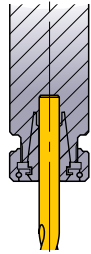
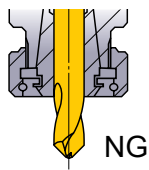
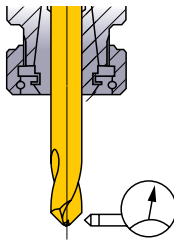
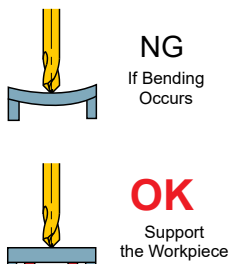
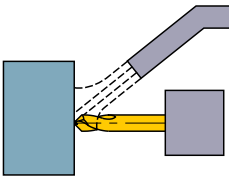
Drill Holding	Drill Installation	Installation Tolerance	Thin Workpiece	Coolant Method
 <p>Collet chuck holds the drill securely.</p>	 <p>Do not clamp on the flutes.</p>	 <p>Run-out $\leq .001$ inch</p>	 <p>NG If Bending Occurs</p> <p>OK Support the Workpiece</p>	 <p>Coolant positions, at the end at the center are ideal.</p>

Cutting Performance

Comparison of Cutting Performance during Centering

Ideal for processing at low power, when compared to conventional products.

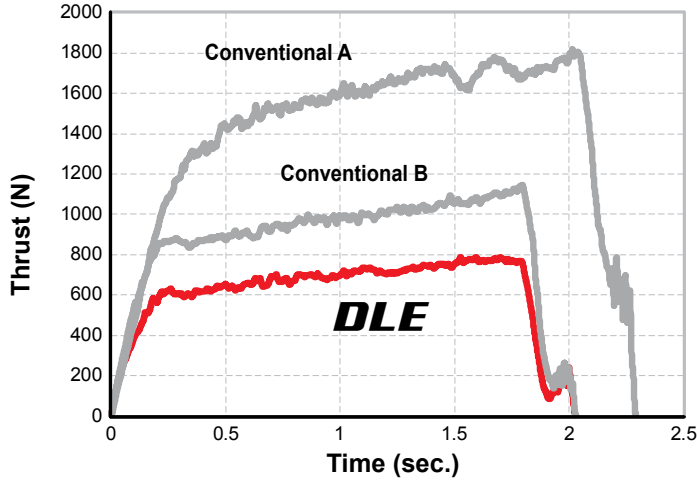

<Cutting Conditions>
 Work Material : AISI 1045
 Drill : DLE1200S120P090
 ø.472"
 Cutting Speed : vc = 195 SFM
 Feed per Rev. : fr = .0024 IPR"
 Cutting Mode : Wet Cutting
 External Coolant
 (Chlorine Free Emulsion)
 Machine : Vertical MC

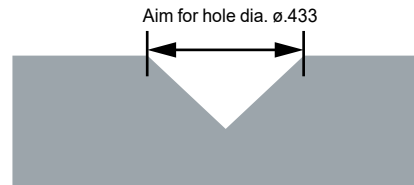

*Differences along the time axis are a result of differences in processing depth.

Centering Hole Position Precision for 400 Series Stainless



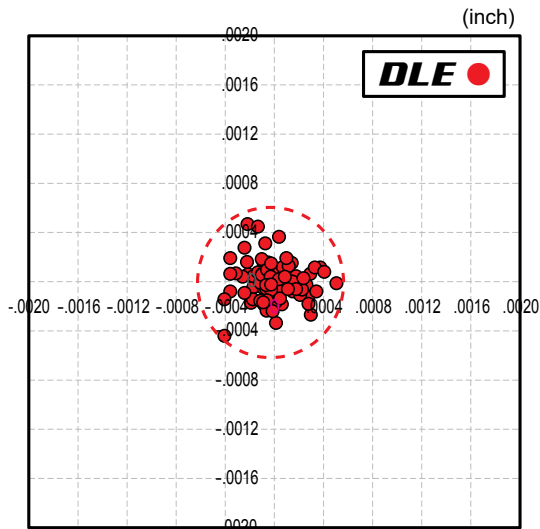



Stainless steels are likely to experience abnormal damage from build-up edge. Compared to conventional products which often suffered early fractures, the DLE has longer tool life.

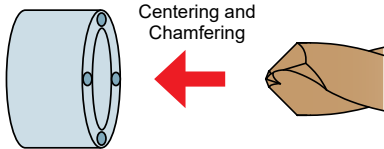
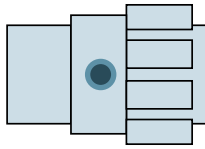

<Cutting Conditions>
 Work Material : 420 Stainless
 Drill : DLE0600S060P090
 Cutting Speed : vc = 50 SFM
 Feed per Rev. : fr = .0016 IPR
 Hole Depth : Aim for hole dia. ø.217"
 Cutting Mode : Wet Cutting
 External Coolant
 (Chlorine Free Emulsion)
 Machine : Vertical MC

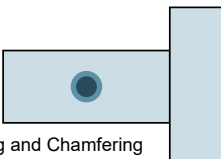

Application Examples

Drill		DLE0400S040P090	DLE0600S060P090
Workpiece		AISI 1010 (Equipment Parts) Centering and Chamfering 	AISI 304 (Machine Parts)  Centering and Chamfering
	Cutting Conditions		
	Cutting Speed vc (SFM)	100	80
	Feed per Rev. fr (IPR)	.0018	.0020
	Guide Hole Dia. (inch)	ø.118	ø.197
Cutting Mode		Wet Cutting External Coolant (Chlorine Free Emulsion)	Wet Cutting External Coolant (Water-insoluble)
Machine		NC Lathe, Tool Rotation	CNC Automatic Lathe
Results		 Burs are suppressed Compared to conventional products, the DLE has smaller burrs and a longer expected life.	 More than 200 holes Good surface finishes and no tool damage While conventional products often caused chipping to occur, the DLE is more stable and has been used to complete drilling of 200 holes with no damage on the cutting edge.
Drill		DLE0300S030P090	
Workpiece		AISI 303 (Engine Parts) Centering and Chamfering 	
	Cutting Conditions		
	Cutting Speed vc (SFM)	80	
	Feed per Rev. fr (IPR)	.0016	
	Guide Hole Dia. (inch)	ø.079	
Cutting Mode		Wet Cutting External Coolant (Water-insoluble) Curved Surface	
Machine		CNC Automatic Lathe	
Results		DLE  After 60 Holes	Conventional  After 1 Hole
			While conventional products generated burrs after the first hole, the DLE achieved 60 holes without noticeable damage and burrs, plus provided excellent surface finish.

The above application examples are customer's applications, so it can be different from the recommended conditions.



PRODUCT EXTENSION

DIA  **EDGE**

MFE SERIES

HIGH EFFICIENCY DRILLING
for various types of machining



External Coolant

(inch)

DC					L/D	Order Number	Stock	LU		LCF		LH		OAL		DCON		Type
Metric (mm)	Decimal	Fraction	Wire / Letter	Thread Size			DP102A	mm	inch	mm	inch	mm	inch	mm	inch	mm	inch	
	(inch)																	
0.750	.0295				2	MFE0075X02S030	●	1.5	.059	3.0	.118	7.7	.303	45	1.772	3	.118	1
0.800	.0315				2	MFE0080X02S030	●	1.6	.063	3.2	.126	7.8	.307	45	1.772	3	.118	1
0.850	.0335				2	MFE0085X02S030	●	1.7	.067	3.4	.134	7.9	.311	45	1.772	3	.118	1
0.900	.0354				2	MFE0090X02S030	●	1.8	.071	3.6	.142	8.0	.315	45	1.772	3	.118	1
0.950	.0374				2	MFE0095X02S030	●	1.9	.075	3.8	.150	8.1	.319	45	1.772	3	.118	1
1.000	.0394				2	MFE0100X02S030	●	2.0	.079	4.0	.157	8.2	.323	45	1.772	3	.118	1
1.050	.0413				2	MFE0105X02S030	●	2.1	.083	4.2	.165	8.3	.327	45	1.772	3	.118	1
1.100	.0433				2	MFE0110X02S030	●	2.2	.087	4.4	.173	8.4	.331	45	1.772	3	.118	1
1.150	.0453				2	MFE0115X02S030	●	2.3	.091	4.6	.181	8.6	.339	45	1.772	3	.118	1
1.200	.0472				2	MFE0120X02S030	●	2.4	.094	4.8	.189	8.7	.343	45	1.772	3	.118	1

Drilling

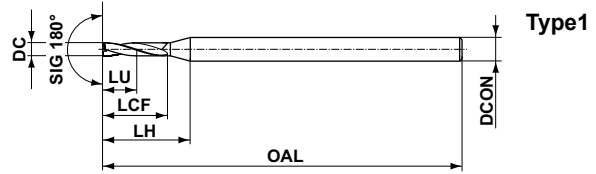

	.0295 ≤ DC ≤ .1161				(inch)
	0				
	-0.00055				
	DCON = .118		.118 < DCON ≤ .157		
h6	0				
	-0.00024		0	-0.00031	

External Coolant

Metric (mm)	DC				L/D	Order Number	Stock DP102A	LU		LCF		LH		OAL		DCON		Type
	Decimal	Fraction	Wire / Letter	Thread Size				mm	inch	mm	inch	mm	inch	mm	inch	mm	inch	
	(inch)																	
1.250	.0492				2	MFE0125X02S030	●	2.5	.098	5.0	.197	8.8	.346	45	1.772	3	.118	1
1.300	.0512				2	MFE0130X02S030	●	2.6	.102	5.2	.205	8.9	.350	45	1.772	3	.118	1
1.350	.0531				2	MFE0135X02S030	●	2.7	.106	5.4	.213	9.0	.354	45	1.772	3	.118	1
1.400	.0551				2	MFE0140X02S030	●	2.8	.110	5.6	.220	9.1	.358	45	1.772	3	.118	1
1.450	.0571				2	MFE0145X02S030	●	2.9	.114	5.8	.228	9.2	.362	45	1.772	3	.118	1
1.500	.0591				2	MFE0150X02S030	●	3.0	.118	6.0	.236	9.3	.366	45	1.772	3	.118	1
1.550	.0610				2	MFE0155X02S030	●	3.1	.122	6.2	.244	9.4	.370	45	1.772	3	.118	1
1.600	.0630				2	MFE0160X02S030	●	3.2	.126	6.4	.252	9.5	.374	45	1.772	3	.118	1
1.650	.0650				2	MFE0165X02S030	●	3.3	.130	6.6	.260	9.6	.378	45	1.772	3	.118	1
1.700	.0669				2	MFE0170X02S030	●	3.4	.134	6.8	.268	9.7	.382	45	1.772	3	.118	1
1.750	.0689				2	MFE0175X02S030	●	3.5	.138	7.0	.276	9.8	.386	45	1.772	3	.118	1
1.800	.0709				2	MFE0180X02S030	●	3.6	.142	7.2	.283	9.9	.390	45	1.772	3	.118	1
1.850	.0728				2	MFE0185X02S030	●	3.7	.146	7.4	.291	10.0	.394	45	1.772	3	.118	1
1.900	.0748				2	MFE0190X02S030	●	3.8	.150	7.6	.299	10.2	.402	45	1.772	3	.118	1
1.950	.0768				2	MFE0195X02S030	●	3.9	.154	7.8	.307	10.3	.406	45	1.772	3	.118	1
2.000	.0787			#3-48	2	MFE0200X02S040	●	4.0	.157	8.0	.315	12.2	.480	50	1.969	4	.157	1
2.050	.0807				2	MFE0205X02S040	●	4.1	.161	8.2	.323	12.3	.484	50	1.969	4	.157	1
2.100	.0827				2	MFE0210X02S040	●	4.2	.165	8.4	.331	12.4	.488	50	1.969	4	.157	1
2.150	.0846				2	MFE0215X02S040	●	4.3	.169	8.6	.339	12.6	.496	50	1.969	4	.157	1
2.200	.0866				2	MFE0220X02S040	●	4.4	.173	8.8	.346	12.7	.500	50	1.969	4	.157	1
2.250	.0886				2	MFE0225X02S040	●	4.5	.177	9.0	.354	12.8	.504	50	1.969	4	.157	1
2.300	.0906				2	MFE0230X02S040	●	4.6	.181	9.2	.362	12.9	.508	50	1.969	4	.157	1
2.350	.0925				2	MFE0235X02S040	●	4.7	.185	9.4	.370	13.0	.512	50	1.969	4	.157	1
2.400	.0945				2	MFE0240X02S040	●	4.8	.189	9.6	.378	13.1	.516	50	1.969	4	.157	1
2.450	.0965				2	MFE0245X02S040	●	4.9	.193	9.8	.386	13.2	.520	50	1.969	4	.157	1
2.500	.0984				2	MFE0250X02S040	●	5.0	.197	10.0	.394	13.3	.524	50	1.969	4	.157	1
2.550	.1004				2	MFE0255X02S040	●	5.1	.201	10.2	.402	13.4	.528	50	1.969	4	.157	1
2.600	.1024				2	MFE0260X02S040	●	5.2	.205	10.4	.409	13.5	.531	50	1.969	4	.157	1
2.650	.1043				2	MFE0265X02S040	●	5.3	.209	10.6	.417	13.6	.535	50	1.969	4	.157	1
2.700	.1063		36	#6-32	2	MFE0270X02S040	●	5.4	.213	10.8	.425	13.7	.539	50	1.969	4	.157	1
2.750	.1083				2	MFE0275X02S040	●	5.5	.217	11.0	.433	13.8	.543	50	1.969	4	.157	1
2.800	.1102		35		2	MFE0280X02S040	●	5.6	.220	11.2	.441	13.9	.547	50	1.969	4	.157	1
2.850	.1122				2	MFE0285X02S040	●	5.7	.224	11.4	.449	14.0	.551	50	1.969	4	.157	1
2.900	.1142				2	MFE0290X02S040	●	5.8	.228	11.6	.457	14.2	.559	50	1.969	4	.157	1
2.950	.1161		32		2	MFE0295X02S040	●	5.9	.232	11.8	.465	14.3	.563	50	1.969	4	.157	1

* See Index on page 4 for table icon reference. (●, ★, □)

PRODUCT EXTENSION

DIA  **EDGE**

MVX SERIES



HIGH EFFICIENCY DRILLING
for various types of machining



Machining Tolerance (Guide)(inch)

L/D	ø.562"–ø.656"
2, 3	+ 0 .0098
4, 5	+ 0 .0138



Maximum Offset for Turning

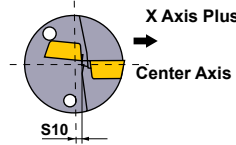

Type 1

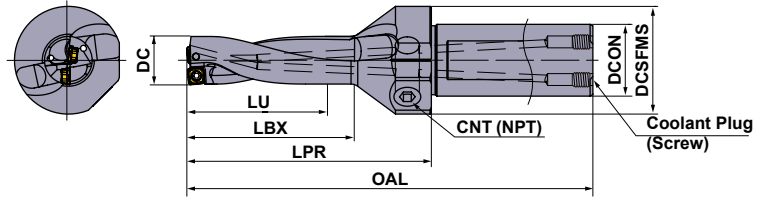

Type 2

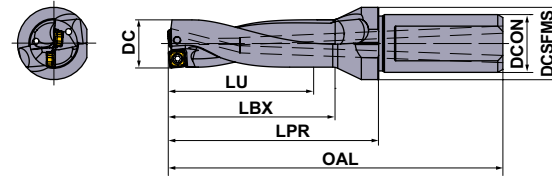

Side Coolant Not Available.

Internal Coolant

(inch)

DC	Hole Depth (L/D)	Order Number	Stock	#2 No.T	LU	LBX	LPR	OAL	DCON	DCSFMS	S10	Type	Insert Type	*1	NPT Plug (Side)	Coolant Plug (Screw) (Back)	Coolant Plug (Wrench)	
														Clamp Screw				Wrench
NEW .562	2	MVX0562X2C075	●	2	1.12	1.40	2.19	4.19	.750	1.25	.026	1	SOX05	TPS20-1	TIP06F	1/8	HSS05006	HKY25R
	3	MVX0562X3C075	●	2	1.69	1.96	2.75	4.75	.750	1.25	.026	1	SOX05	TPS20-1	TIP06F	1/8	HSS05006	HKY25R
	4	MVX0562X4C075	●	2	2.25	2.52	3.32	5.32	.750	1.25	.026	1	SOX05	TPS20-1	TIP06F	1/8	HSS05006	HKY25R
	5	MVX0562X5F075	●	2	2.81	3.09	3.61	5.61	.750	.98	.026	2	SOX05	TPS20-1	TIP06F	—	—	—
NEW .593	2	MVX0593X2C075	●	2	1.19	1.46	2.25	4.25	.750	1.25	.016	1	SOX05	TPS20-1	TIP06F	1/8	HSS05006	HKY25R
	3	MVX0593X3C075	●	2	1.78	2.06	2.85	4.85	.750	1.25	.016	1	SOX05	TPS20-1	TIP06F	1/8	HSS05006	HKY25R
	4	MVX0593X4C075	●	2	2.37	2.65	3.44	5.44	.750	1.25	.016	1	SOX05	TPS20-1	TIP06F	1/8	HSS05006	HKY25R
	5	MVX0593X5F075	●	2	2.97	3.24	3.77	5.77	.750	.98	.016	2	SOX05	TPS20-1	TIP06F	—	—	—
NEW .625	2	MVX0625X2C075	●	2	1.25	1.53	2.32	4.32	.750	1.25	.013	1	SOX05	TPS20-1	TIP06F	1/8	HSS05006	HKY25R
	3	MVX0625X3C075	●	2	1.88	2.15	2.94	4.94	.750	1.25	.013	1	SOX05	TPS20-1	TIP06F	1/8	HSS05006	HKY25R
	4	MVX0625X4C075	●	2	2.50	2.78	3.57	5.57	.750	1.25	.013	1	SOX05	TPS20-1	TIP06F	1/8	HSS05006	HKY25R
	5	MVX0625X5F075	●	2	3.13	3.40	3.93	5.93	.750	.98	.013	2	SOX05	TPS20-1	TIP06F	—	—	—
NEW .656	2	MVX0656X2C075	●	2	1.31	1.59	2.38	4.38	.750	1.25	.009	1	SOX05	TPS20-1	TIP06F	1/8	HSS05006	HKY25R
	3	MVX0656X3C075	●	2	1.97	2.24	3.04	5.04	.750	1.25	.009	1	SOX05	TPS20-1	TIP06F	1/8	HSS05006	HKY25R
	4	MVX0656X4C075	●	2	2.62	2.90	3.69	5.69	.750	1.25	.009	1	SOX05	TPS20-1	TIP06F	1/8	HSS05006	HKY25R
	5	MVX0656X5F075	●	2	3.28	3.56	4.08	6.08	.750	.98	.009	2	SOX05	TPS20-1	TIP06F	—	—	—

*1 Clamp Torque (lbf-in) : TPS20-1=5.3

*2 Number of Teeth

MVX SERIES



(Metric)

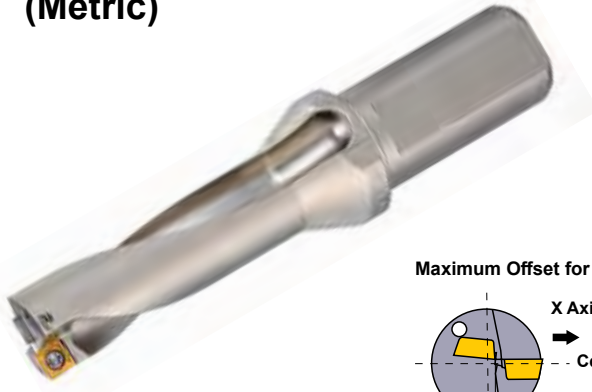

Maximum Offset for Turning

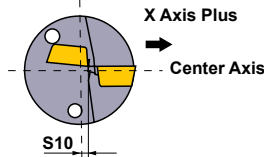

Machining Tolerance (Guide)(mm)

L/D	ø14-ø33	ø33.5-ø47	ø48-ø63
2, 3	+0.25 0	+0.3 0	+0.3 0
4, 5	+0.35 0	+0.4 0	+0.45 0
6	+0.45 0	+0.6 0	-

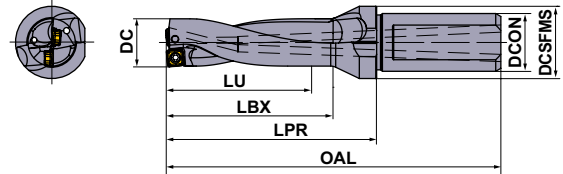

Side Coolant Not Available.

(mm)

DC	Hole Depth (L/D)	Order Number	Stock	*2 No.T	LU	LBX	LPR	OAL	DCON	DCSFMS	S10	Insert Type	*1	
													Clamp Screw	Wrench
NEW 14.0	2	MVX1400X2F20	★	2	28	35	50	93	20	25	0.6	SOX05	TPS20-1	TIP06F
	3	MVX1400X3F20	★	2	42	49	64	107	20	25	0.6	SOX05	TPS20-1	TIP06F
	4	MVX1400X4F20	★	2	56	63	78	121	20	25	0.6	SOX05	TPS20-1	TIP06F
	5	MVX1400X5F20	★	2	70	77	92	135	20	25	0.6	SOX05	TPS20-1	TIP06F
NEW 14.5	2	MVX1450X2F20	★	2	29	36	51	94	20	25	0.5	SOX05	TPS20-1	TIP06F
	3	MVX1450X3F20	★	2	43.5	50.5	65.5	108.5	20	25	0.5	SOX05	TPS20-1	TIP06F
	4	MVX1450X4F20	★	2	58	65	80	123	20	25	0.5	SOX05	TPS20-1	TIP06F
	5	MVX1450X5F20	★	2	72.5	79.5	94.5	137.5	20	25	0.5	SOX05	TPS20-1	TIP06F
NEW 15.0	2	MVX1500X2F20	★	2	30	37	52	95	20	25	0.35	SOX05	TPS20-1	TIP06F
	3	MVX1500X3F20	★	2	45	52	67	110	20	25	0.35	SOX05	TPS20-1	TIP06F
	4	MVX1500X4F20	★	2	60	67	82	125	20	25	0.35	SOX05	TPS20-1	TIP06F
	5	MVX1500X5F20	★	2	75	82	97	140	20	25	0.35	SOX05	TPS20-1	TIP06F
NEW 15.5	2	MVX1550X2F20	★	2	31	38	53	96	20	25	0.3	SOX05	TPS20-1	TIP06F
	3	MVX1550X3F20	★	2	46.5	53.5	68.5	111.5	20	25	0.3	SOX05	TPS20-1	TIP06F
	4	MVX1550X4F20	★	2	62	69	84	127	20	25	0.3	SOX05	TPS20-1	TIP06F
	5	MVX1550X5F20	★	2	77.5	84.5	99.5	142.5	20	25	0.3	SOX05	TPS20-1	TIP06F
NEW 16.0	2	MVX1600X2F20	★	2	32	39	54	97	20	25	0.25	SOX05	TPS20-1	TIP06F
	3	MVX1600X3F20	★	2	48	55	70	113	20	25	0.25	SOX05	TPS20-1	TIP06F
	4	MVX1600X4F20	★	2	64	71	86	129	20	25	0.25	SOX05	TPS20-1	TIP06F
	5	MVX1600X5F20	★	2	80	87	102	145	20	25	0.25	SOX05	TPS20-1	TIP06F
NEW 16.5	2	MVX1650X2F20	★	2	33	40	55	98	20	25	0.25	SOX05	TPS20-1	TIP06F
	3	MVX1650X3F20	★	2	49.5	56.5	71.5	114.5	20	25	0.25	SOX05	TPS20-1	TIP06F
	4	MVX1650X4F20	★	2	66	73	88	131	20	25	0.25	SOX05	TPS20-1	TIP06F
	5	MVX1650X5F20	★	2	82.5	89.5	104.5	147.5	20	25	0.25	SOX05	TPS20-1	TIP06F
17.0	2	MVX1700X2F20	★	2	34	41	56	99	20	25	0.5	SOX06	TPS25	TIP07F
	3	MVX1700X3F20	★	2	51	58	73	116	20	25	0.5	SOX06	TPS25	TIP07F
	4	MVX1700X4F20	★	2	68	75	90	133	20	25	0.5	SOX06	TPS25	TIP07F
	5	MVX1700X5F20	★	2	85	92	107	150	20	25	0.5	SOX06	TPS25	TIP07F
	6	MVX1700X6F20	★	2	102	109	124	167	20	25	0.5	SOX06	TPS25	TIP07F

*1 Clamp Torque (lbf-in) : TPS20-1=5.3, TPS25=8.9

*2 Number of Teeth

DC = Cutting Diameter
 LU = Usable Length
 LBX = Usable Length
 LPR = Protruding Length

OAL = Overall Length
 DCON = Fixing Part Depth
 DCSFMS = Flange Diameter

JUST FIT SLEEVE [JFS]

(Inch)

● A sleeve for the shank of the drill to allow the cutting diameter to be increased.

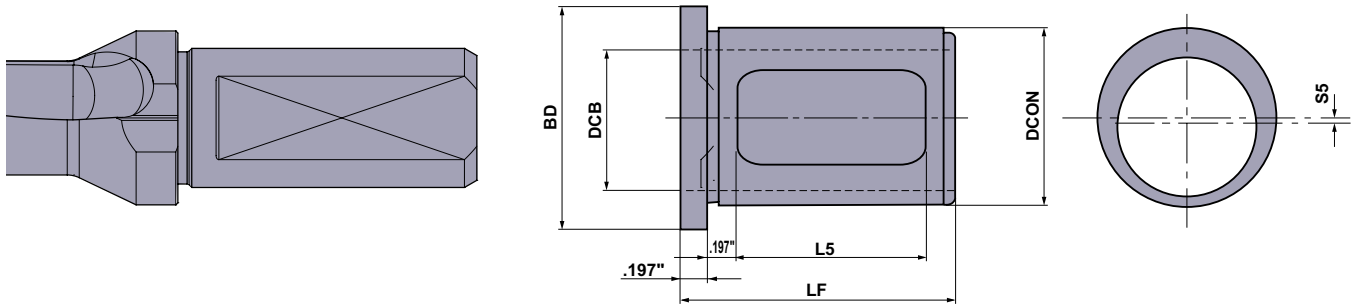

(inch)

Order Number	Stock	DCB	DCON	BD	LF	L5	*Increase (S5×2)	MVX Order Number The Last Four Letters
JFS125100-005	●	1.000	1.250	1.813	2.250	1.625	.005	C100
JFS125100-010	●	1.000	1.250	1.813	2.250	1.625	.010	C100
JFS125100-015	●	1.000	1.250	1.813	2.250	1.625	.015	C100
JFS125100-020	●	1.000	1.250	1.813	2.250	1.625	.020	C100
JFS125100-025	●	1.000	1.250	1.813	2.250	1.625	.025	C100
JFS150125-005	●	1.250	1.500	2.063	2.370	1.750	.005	C125
JFS150125-010	●	1.250	1.500	2.063	2.370	1.750	.010	C125
JFS150125-015	●	1.250	1.500	2.063	2.370	1.750	.015	C125
JFS150125-020	●	1.250	1.500	2.063	2.370	1.750	.020	C125
JFS150125-025	●	1.250	1.500	2.063	2.370	1.750	.025	C125
JFS175150-005	●	1.500	1.750	2.313	2.780	2.156	.005	C150
JFS175150-010	●	1.500	1.750	2.313	2.780	2.156	.010	C150
JFS175150-015	●	1.500	1.750	2.313	2.780	2.156	.015	C150
JFS175150-020	●	1.500	1.750	2.313	2.780	2.156	.020	C150
JFS175150-025	●	1.500	1.750	2.313	2.780	2.156	.025	C150

It does not correspond to the shank diameter ø.750".

*Increase : Size of the increase in the cutting diameter.

■ Guideline for Selecting a JUST FIT SLEEVE

Desired = (Drillø + Increase of JFS) + .005"

(Eg.) Desired diameter is 1.015" (oversize is taken as .005").

$$\phi 1.015 = (\text{MVX1000 X } \odot \text{C125} + \text{JFS150125-010}) + .005$$

1.000" Drill

Using JFS an Increase of .010".

Oversize

<Tool Selected>
 MVX : MVX1000 X \odot C125
 JUST FIT SLEEVE [JFS]
 : JFS150125-010

Note 1) Oversize can vary due to the cutting conditions used, please use the above as a guideline.



**COMPLETE
METALWORKING
SOLUTIONS**

(800) 991-4225

www.ahbinc.com

ISO Certified

customerservice@ahbinc.com

For Your Safety

- Don't handle inserts and chips without gloves.
- Please machine within the recommended application range and exchange expired tools with new ones in advance of breakage.
- Please use safety covers and wear safety glasses.
- When using compounded cutting oils, please take fire precautions.
- When attaching inserts or spare parts, please use only the correct wrench or driver.
- When using rotating tools, please make a trial run to check run-out, vibration and abnormal sounds etc.

MITSUBISHI MATERIALS, USA CORPORATION

California Office

11250 Slater Avenue
Fountain Valley, CA 92708

North Carolina-Technical Education Center

105 Corporate Center Drive
 Mooresville, NC 28117

Chicago Office

1314B North Plum Grove Road
 Schaumburg, IL 60173

Toronto Office

3535 Laird Road
 Units 15 & 16
 Mississauga, Ontario, Canada L5L 5Y7

MMC METAL DE MEXICO, S.A. DE C.V.

Av. La Cañada No.16, Parque Industrial Bernardo
 Quintana, El Marques, Queretaro C.P. 76246 MEXICO

www.mmus-carbide.com

TOOLS SPECIFICATIONS SUBJECT TO CHANGE WITHOUT NOTICE.



Follow Us

