

Specifications for PMC

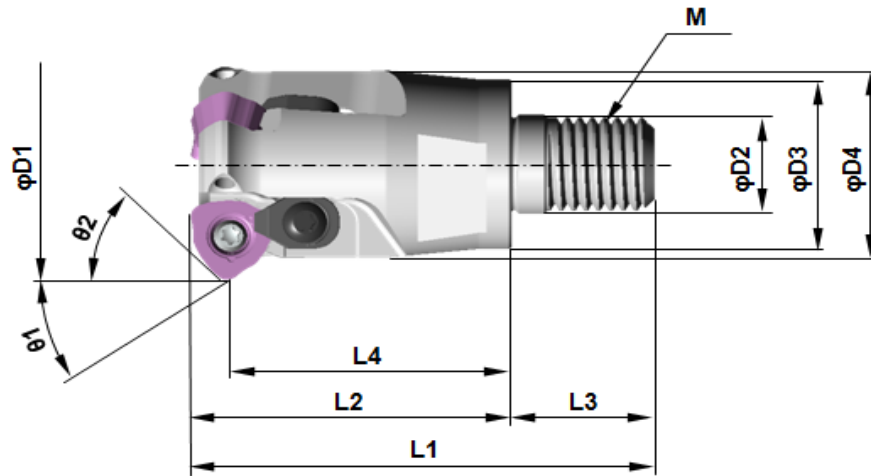

Order Number	Number of Flute	Dimensions											Insert Screw	Clamp Bridge	Clamp Bridge Screw	Spring	Wrench	Insert
		D1	D2	D3	D4	M	L1	L2	L3	L4	$\theta 1$	$\theta 2$						
PMC08R252AM1035	2	25	10.5	18	21	M10	58.7	39.7	19	35	35	40.5	TS33	AMS3	AJS3010T 10	ASS2	TKY08D TKY10D	JOMW080320 ZZ SR-FT
PMC09R323AM1245	3	32	12.5	21	25	M12	72.5	50.5	22	45	35	40.5	TS351	AMS3	AJS3010T 10	ASS2	TKY10D	JDMW09T320 ZDSR-FT
PMC12R403AM1645	3	40	17	29	32	M16	74.4	51.4	23	45	35	42	TS43	AMS4	AJS4012T 15	ASS2	TKY15D	JDMW120420 ZDSR-FT