

MICHIGAN MADE

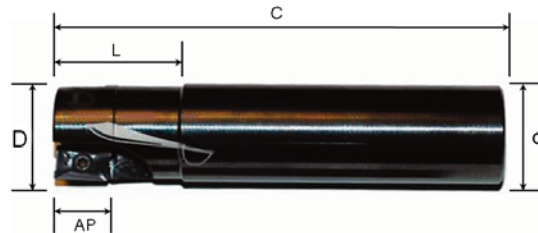

B

MILLING

End Mill Cutters

No Coolant

Designation	D	Flutes	C	L	AP	d	Insert	Screw	Price
E90AP D.500-1-W.500-11	.500	1	3.375	.975	.315	.500	APKT 11T308	SR34505	\$89.00
E90AP D.625-2-W.625-11	.625	2	3.375	.975	.315	.625		SR34505	\$89.00
E90AP D.750-2-W.750-11	.750	2	3.375	.975	.315	.750		SR34505L	\$99.00
E90AP D.750-3-W.750-11	.750	3	3.375	.975	.315	.750		SR34505L	\$109.00
E90AP D.750-3-W.750-6-11	.750	3	6.000	3.000	.315	.750		SR34505L	\$139.00
E90AP D1.00-3-W.750-11	1.000	3	4.000	1.500	.315	.750		SR34505L	\$109.00
E90AP D1.00-3-W1.00-11	1.000	3	4.000	1.500	.315	1.000		SR34505L	\$119.00
E90AP D1.00-3-W1.00-6-11	1.000	3	6.000	3.000	.315	1.000		SR34505L	\$149.00
E90AP D1.00-4-W1.00-11	1.000	4	4.000	1.500	.315	1.000		SR34505L	\$129.00
E90AP D1.250-3-W.750-11	1.250	3	4.000	1.500	.315	.750		SR34505L	\$119.00
E90AP D1.250-3-W1.00-11	1.250	3	4.000	1.500	.315	1.000		SR34505L	\$129.00
E90AP D1.500-5-W1.00-11	1.500	5	4.000	1.500	.315	1.000		SR34505L	\$139.00
E90AP D1.00-2-W1.00-16	1.000	2	4.000	1.750	.472	1.000	APKT 160408	SR14544	\$109.00
E90AP D1.250-2-W1.00-16	1.250	2	4.000	1.500	.472	1.000		SR14544	\$119.00
E90AP D1.250-3-W1.00-16	1.250	3	4.000	1.500	.472	1.000		SR14544	\$129.00
E90AP D1.500-3-W1.00-16	1.500	3	4.000	1.500	.472	1.000		SR14544	\$129.00

End Mill Cutters

Coolant Thru

Designation	D	Flutes	C	L	AP	d	Insert	Screw	Price
E90AP D.750-2-W.750-11-C	.750	2	3.375	.975	.315	.750	APKT 11T308	SR34505L	\$114.00
E90AP D.750-3-W.750-11-C	.750	3	3.375	.975	.315	.750		SR34505L	\$129.00
E90AP D1.00-3-W1.00-11-C	1.000	3	4.000	1.500	.315	1.000		SR34505L	\$139.00
E90AP D1.250-3-W1.00-16-C	1.250	3	4.000	1.500	.472	1.000	APKT 160408	SR14544	\$149.00
E90AP D1.500-3-W1.00-16-C	1.500	3	4.000	1.500	.472	1.000		SR14544	\$149.00



Hardware
pg: 112



Inserts
pg: 103

End / Face Mill Cutters

ULTRA-DEX USA

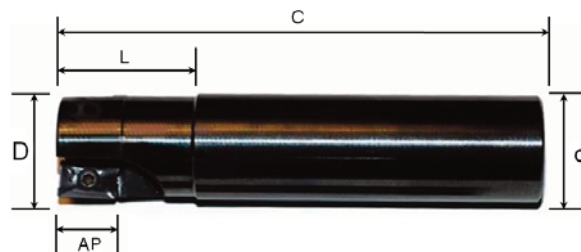

End Mill Cutter Bodies to fit Industry Standard Inserts

No Coolant

Designation	D	Flutes	C	L	AP	d	Insert	Screw	Price
E90AP D.750-2-W.750-10	.750	2	3.375	.975	.394	.750	APKT 1003	SR34505L	\$109.00
E90AP D.750-3-W.750-10	.750	3	3.375	.975	.394	.750		SR34505L	\$129.00
E90AP D1.00-3-W.750-10	1.000	3	4.000	1.500	.394	.750		SR34505L	\$139.00
E90AP D1.00-3-W1.00-10	1.000	3	4.000	1.500	.394	1.000		SR34505L	\$139.00
E90AP D1.250-3-W.750-10	1.250	3	4.000	1.500	.394	.750		SR34505L	\$139.00
E90AP D1.250-3-W1.00-10	1.250	3	4.000	1.500	.394	1.000		SR34505L	\$139.00
E90AP D1.00-2-W1.00-15	1.000	2	4.000	1.750	.562	1.000	ADKT 1505	SR14544	\$139.00
E90AP D1.250-2-W1.00-15	1.250	2	4.000	1.500	.562	1.000		SR14544	\$139.00
E90AP D1.250-3-W1.00-15	1.250	3	4.000	1.500	.562	1.000		SR14544	\$139.00
E90AP D1.500-3-W1.00-15	1.500	3	4.000	1.500	.562	1.000		SR14544	\$149.00

B

MILLING

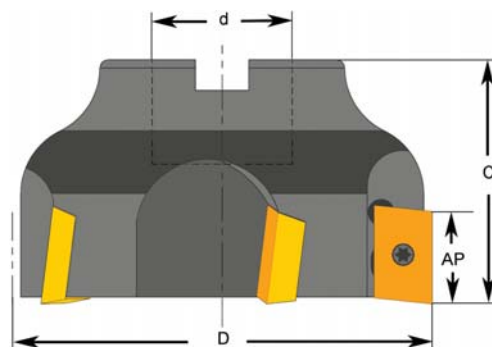

Face Mill Cutters

No Coolant

Designation	D	Flutes	C	AP	d	Inserts	Screw	Price
F90AP D2.00-5-.750-11	2.000	5	1.570	.315	.750	APKT 11T308	SR34505L	\$185.00
F90AP D2.50-7-1.00-11	2.500	7	1.750	.315	1.000		SR34505L	\$249.00
F90AP D3.00-8-1.00-11	3.000	8	1.750	.315	1.000		SR34505L	\$309.00
F90AP D2.00-5-.750-16	2.000	5	1.570	.472	.750	APKT 160408	SR14544	\$180.00
F90AP D2.50-5-1.00-16	2.500	5	1.750	.472	1.000		SR14544	\$237.00
F90AP D3.00-5-1.00-16	3.000	5	1.750	.472	1.000		SR14544	\$290.00
F90AP D3.00-7-1.00-16	3.000	7	1.750	.472	1.000		SR14544	\$309.00
F90AP D4.00-8-1.25-16	4.000	7	1.750	.472	1.250		SR14544	\$375.00

Cutting Conditions

APKT 11T308

Feed Per Tooth (inch)

Depth of cut ↑	AP (inch)	Light	Medium	Heavy
	.315	.0028	.0031	.0039
	.236	.0039	.0047	.0059
	.157	.0047	.0059	.0079

f/t →

APKT 160408

Feed Per Tooth (inch)

Depth of cut ↑	AP (inch)	Light	Medium	Heavy
	.472	.0028	.0031	.0039
	.315	.0039	.0047	.0059
	.197	.0047	.0059	.0079

f/t →



NEW!

Chamfer Mill Cutters

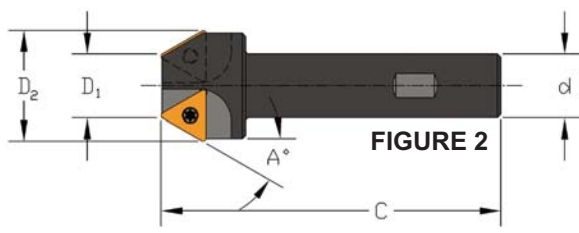
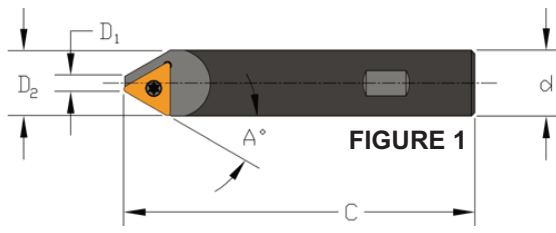

B

MILLING

Chamfer Mill Cutters

No Coolant

Designation	Figure	A°	D1	D2	C	d	Insert	Screw	Price
E05C-D.500-1-.750-3	1	5	.500	.594	4.000	.750	TCMT 32.52	MTS-35	\$84.00
E10C-D.500-1-.750-3	1	10	.500	.688	4.000	.750		MTS-35	\$84.00
E15C-D.500-1-.750-3	1	15	.500	.782	4.000	.750		MTS-35	\$84.00
E15C-D1.00-2-.750-3	2	15	1.000	1.280	4.000	.750		MTS-35	\$99.00
E20C-D.375-1-.750-3	1	20	.375	.750	4.000	.750		MTS-35	\$84.00
E30C-D.250-1-.750-3	1	30	.250	.800	4.000	.750		MTS-35	\$84.00
E30C-D.750-2-.750-3	2	30	.750	1.300	4.000	.750		MTS-35	\$99.00
E41C-D.188-1-.750-3	1	41	.188	.914	4.000	.750		MTS-35	\$84.00
E41C-D.562-2-.750-3	2	41	.562	1.288	4.000	.750		MTS-35	\$99.00
E45C-D.188-1-.750-3	1	45	.188	.972	4.000	.750		MTS-35	\$84.00
E45C-D.500-2-.750-3	2	45	.500	1.290	4.000	.750		MTS-35	\$99.00
E60C-D.188-2-.750-3	2	60	.188	1.160	4.000	.750		MTS-35	\$99.00

**MICHIGAN
MADE**



Hardware
pg: 112



Inserts
pg: 103

Proudly Made in Flushing, MI USA

Round End / Face Mill Cutters

ULTRA-DEX USA

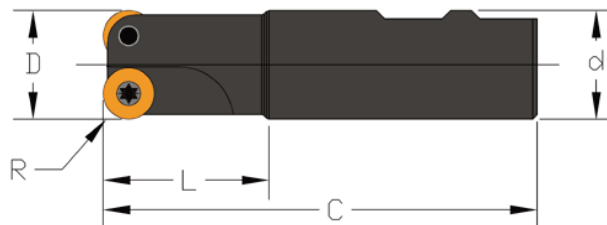

Round End Mill Cutters

No Coolant

Designation	D	Flutes	R	C	L	d	Insert	Screw	Price
ER-D.750-2-.750-08	.750	2	.157 / 4mm	3.380	.975	.750	RDKW 0803	MTS 3-DR	\$119.00
ER-D1.00-2-.750-08	1.000	2		3.380	1.500	.750		MTS 3-DR	\$129.00
ER-D1.00-2-.750-10	1.000	2	.197 / 5mm	3.380	1.500	.750	RCKT 10T3	MTS-35	\$129.00
ER-D1.25-3-1.00-10	1.250	3		4.000	1.500	1.000		MTS-35	\$139.00
ER-D1.50-3-1.00-12	1.500	3	.236 / 6mm	4.000	1.500	1.000	RCKT 1204	MTS-35	\$159.00

Designation	D	Flutes	R	C	L	d	Insert	Screw	Price
ER-D.750-2-.750-2	.750	2	.125	3.380	.975	.750	RCMT 21.5	MTS-255	\$119.00
ER-D1.00-2-.750-2	1.000	2		3.380	1.500	.750		MTS-255	\$129.00
ER-D1.00-2-.750-3	1.000	2	.188	3.380	1.500	.750	RCMT 32.5	MTS 4-DR	\$129.00
ER-D1.25-2-1.00-3	1.250	2		4.000	1.500	1.000		MTS 4-DR	\$139.00
ER-D1.50-3-1.00-4	1.500	3	.250	4.000	1.500	1.000	RCMT 43	MTS-4	\$159.00

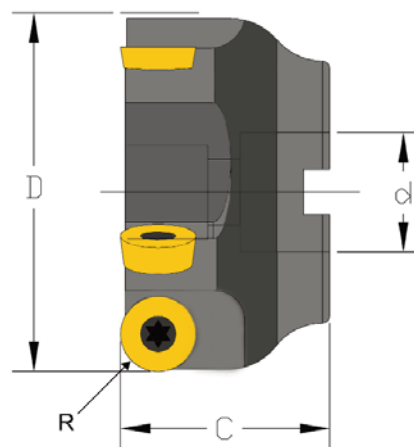

Round Face Mill Cutters

No Coolant

Designation	D	Flutes	R	C	d	Insert	Screw	Price
FR-D2.00-4-.750-12	2.000	4	.236 / 6mm	2.000	.750	RCKT 1204	MTS-35	\$209.00
FR-D2.00-3-.750-16	2.000	3		2.000	.750		MTS-4	\$189.00
FR-D3.00-5-1.00-16	3.000	5	.315 / 8mm	1.750	1.000	RCKT 1606	MTS-4	\$239.00
FR-D4.00-6-1.25-16	4.000	6		1.750	1.250		MTS-4	\$275.00

Designation	D	Flutes	R	C	d	Insert	Screw	Price
FR-D2.00-4-.750-4	2.000	4	.250	2.000	.750	RCMT 43	MTS-4	\$209.00
FR-D3.00-5-1.00-4	3.000	5	.250	1.750	1.000		MTS-4	\$239.00
FR-D4.00-6-1.25-4	4.000	6	.500	1.750	1.250		MTS-4	\$275.00

MADE IN MICHIGAN

ISO Milling Bars Coolant Thru

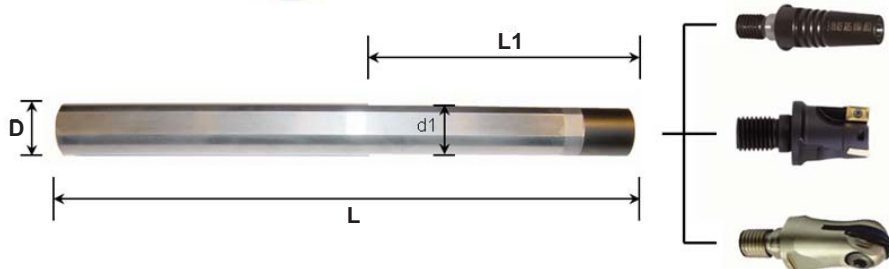

Engineered to fit most threaded ISO milling heads.

Carbide ISO Milling Bar w/ Flat

Designation	L	Thread	L1	D	d1	Price	Designation	L	Thread	L1	D	d1	Price
CM06 L6.00-W.375	6	M6	--	.375	--	\$191.00	CM12 L7.00-W.750	7	M12	4	.750	.710	\$395.00
CM08 L4.00-W.500	4	M8	2.75	.500	.460	\$215.00	CM12 L10.00-W.750	10	M12	7	.750	.710	\$431.00
CM08 L8.00-W.500	8	M8	6.75	.500	.460	\$251.00	CM12 L8.00-W1.00	8	M12	5	1.000	.960	\$587.00
CM10 L7.00-W.750	7	M10	4	.750	.710	\$395.00	CM12 L12.00-W1.00	12	M12	9	1.000	.960	\$743.00
CM10 L10.00-W.750	10	M10	7	.750	.710	\$431.00	CM16 L14.00-W1.25	14	M16	11	1.250	1.210	\$1307.00
							CM16 L14.00-W1.500	14	M16	11	1.500	1.460	\$1602.00

Carbide ISO Milling Bar w/o Flat

Designation	L	Thread	L1	D	d1	Price	Designation	L	Thread	L1	D	d1	Price
CM08 L7.00-C.500	7	M8	5.75	.500	.460	\$251.00	CM12 L7.00-C.750	7	M12	4	.750	.710	\$395.00
CM10 L7.00-C.750	7	M10	4	.750	.710	\$395.00	CM12 L10.00-C.750	10	M12	7	.750	.710	\$431.00
CM10 L10.00-C.750	10	M10	7	.750	.710	\$431.00	CM12 L8.00-C1.00	8	M12	5	1.000	.960	\$597.00
							CM12 L12.00-C1.00	12	M12	9	1.000	.960	\$743.00
							CM16 L14.00-C1.25	14	M16	11	1.250	1.210	\$1307.00

Heavy Metal ISO Milling Bar w/ Flat

Designation	L	Thread	L1	D	d1	Price	Designation	L	Thread	L1	D	d1	Price
HM06 L6.00-W.375	6	M6	--	.375	--	\$195.00	HM12 L12.00-W1.00	12	M12	9	1.000	.960	\$682.00
HM08 L6.00-W.500	6	M8	4.75	.500	.460	\$258.00	HM16 L12.00-W1.25	12	M16	11	1.250	1.210	\$1061.00
HM12 L12.00-W.750	12	M12	4	.750	.710	\$466.00	HM16 L12.00-W1.500	12	M16	11	1.500	1.460	\$1379.00
HM12 L8.00-W1.00	8	M12	5	1.000	.960	\$599.00							

Heavy Metal ISO Milling Bar w/o Flat

Designation	L	Thread	L1	D	d1	Price	Designation	L	Thread	L1	D	d1	Price
HM06 L6.00-C.375	6	M6	--	.375	--	\$195.00	HM12 L8.00-C1.00	8	M12	5	1.000	.960	\$599.00
HM08 L6.00-C.500	6	M8	4.75	.500	.460	\$258.00	HM12 L12.00-C1.00	12	M12	9	1.000	.960	\$682.00
HM12 L12.00-C.750	12	M12	9	.750	.710	\$466.00	HM16 L12.00-C1.25	12	M16	11	1.250	1.210	\$1061.00

Please allow up to 1 week for processing.



Hardware
pg: 112



Inserts
pg: 103

B

MILLING