

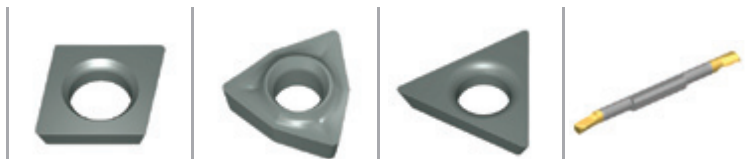

Boring



> Inserts

BORING INSERTS

■ VARDEX Ordering Code System.....	Page 175
■ CD0W Inserts.....	Page 176
■ TD0W Inserts.....	Page 176
■ WC0W Inserts.....	Page 177
■ Boring - Micro.....	Page 178
■ Copy - Micro.....	Page 179
■ Chamfer - Micro.....	Page 179
■ Long Nose - Micro.....	Page 180
■ Back Edge - Micro.....	Page 181
■ Boredrill - Micro.....	Page 181

Vardex Ordering Code System

PowerBore Inserts

T	D	0	W	41	14	VTX
1	2	3	4	5	6	7

1 - Insert Shape C - Diamond 80 deg. T - Triangle W - Trigon 80 deg.	2 - Clearance Angle C - 7 deg. D - 15 deg.	3 - Tolerance Class 0 - Special Tolerance Class	4 - Insert Type W - Hole + Countersink
--	---	---	--

5 - Insert Dimension 40-IC 0.156" - Thickness-0.040" 41-IC 0.160" - Thickness-0.047" 42-IC 0.156" - Thickness-0.062" 50-IC 0.187" - Thickness-0.094"	6 - Corner Radius 11- R 0.02 12- R 0.007 13- R 0.008 14- R 0.015	7 - Carbide Grade VTX
---	---	---------------------------------

Micro Boring Inserts - Double Ended

6.0	S	I	R	0.2	M	-	Bore	-	1	VMX
1	2	3	4	5	6		7		8	9

1 - Insert Dia. (mm) 3.0 4.0 6.0 8.0 10.0	2 - Tool Group S - Solid Carbide	3 - Type of Insert I - Internal	4 - RH or LH R - Right Hand Insert L - Left Hand Insert	5 - Corner Radius (mm) 0.2
---	--	---	--	--------------------------------------

6 - Tool Length U - Ultra Short S - Short M - Medium L - Long	7 - Tool Application Bore - Boring Copy - Boring Copy Chamfer - Boring Chamfer Back - Back Edge 3527, 3537, 3547 - Long Nose BD - Bore Drill	8 - Front Relief 1 - With Relief 0 - Without Relief	9 - Carbide Grade VMX
--	---	--	---------------------------------

Boring

Internal

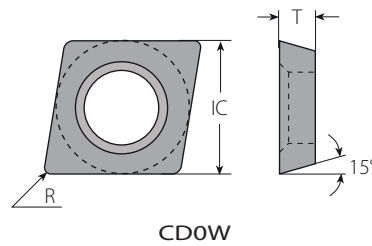
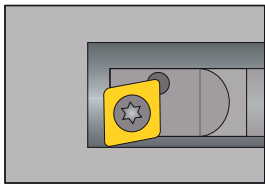

CD0W Inserts for Series A Toolholders

Power Bore



Insert Size	Ordering Code	Dimensions [inch]		Insert Screw 
		R	T	
.156"	CD0W4011...	0.002	0.040	VS01
	CD0W4012...	0.007	0.040	
	CD0W4014...	0.015	0.040	

Internal

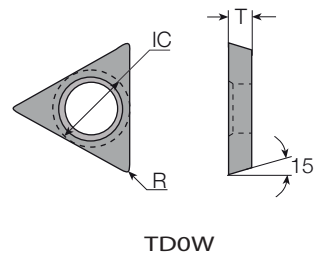
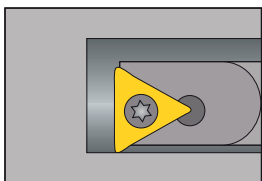

TD0W Inserts for Series B Toolholders

Power Bore

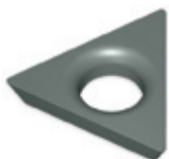

Insert Size	Ordering Code	Dimensions [inch]		Insert Screw 
		R	T	
.160"	TD0W4111...	0.002	0.047	VS01, VS40
	TD0W4112...	0.007	0.047	
	TD0W4114...	0.015	0.047	

Boring



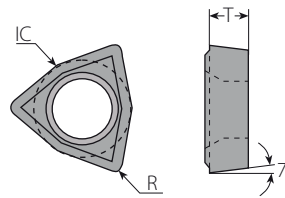
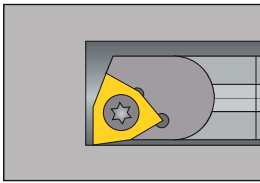

Internal

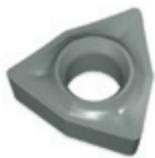

WC0W 4213, 4214

WC0W Inserts for Series E Toolholders



Insert Size	Ordering Code	Dimensions [inch]		Insert Screw 
		R	T	
.156"	WC0W4213...	0.008	0.062	VS40
	WC0W4214...	0.015	0.062	

Internal

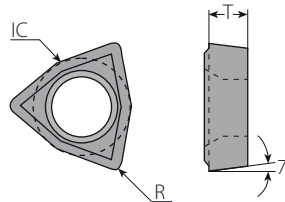
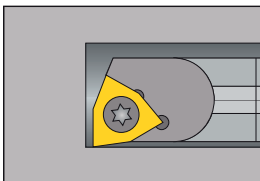

TD0W

WC0W Inserts for Series F Toolholders

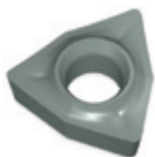

Insert Size	Ordering Code	Dimensions [inch]		Insert Screw 
		R	T	
.187"	WC0W5013...	0.008	0.094	VS41
	WC0W5014...	0.015	0.094	

Micro Boring - Boring



Internal

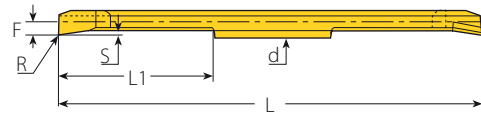
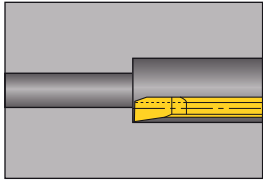

RH-Double Ended

Micro - Double Ended

Insert dia.	Ordering Code	Dimensions inch					Min. Bore dia.	Holder
d (mm)	RH	R	L1	L	S	F	inch	
3.0	3.0SIR0.1U-Bore-1...	0.004	0.23	1.417	0.016	0.009	0.079	SMC...-3.0
	3.0SIR0.1S-Bore-1...	0.004	0.36	1.417	0.016	0.009		
	3.0SIR0.2S-Bore-1...	0.008	0.36	1.417	0.026	0.056		
4.0	3.0SIR0.2M-Bore-1...	0.008	0.64	1.969	0.026	0.056	0.126	SMC...-4.0
	4.0SIR0.2S-Bore-1...	0.008	0.36	1.417	0.026	0.076		
	4.0SIR0.2M-Bore-1...	0.008	0.64	1.969	0.026	0.076		
6.0	4.0SIR0.2L-Bore-1...	0.008	0.84	2.362	0.026	0.076	0.165	SMC...-6.0
	6.0SIR0.2S-Bore-1...	0.008	0.36	1.417	0.030	0.115		
	6.0SIR0.2M-Bore-1...	0.008	0.64	1.969	0.030	0.115		
8.0	6.0SIR0.2L-Bore-1...	0.008	0.84	2.362	0.030	0.115	0.244	SMC...-8.0
	8.0SIR0.2S-Bore-1...	0.008	0.48	2.126	0.032	0.154		
	8.0SIR0.2M-Bore-1...	0.008	0.79	2.756	0.032	0.154		
10.0	8.0SIR0.2L-Bore-1...	0.008	1.09	3.386	0.032	0.154	0.323	SMC...-10.0
	10.0SIR0.2S-Bore-1...	0.008	0.58	2.362	0.039	0.194		
	10.0SIR0.2M-Bore-1...	0.008	0.99	3.150	0.039	0.194		
	10.0SIR0.2L-Bore-1...	0.008	1.37	3.937	0.039	0.194	0.402	

Micro Boring Copy



Internal

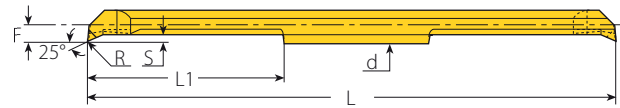
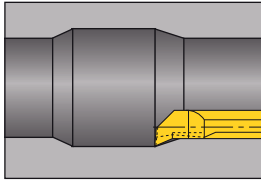

RH-Double Ended

Micro - Double Ended

Insert dia. d (mm)	Ordering Code RH	R	L1	L	S	F	Min. Bore dia. inch	Holder
4.0	4.0SIR0.2S-Copy-1...	0.008	0.36	1.417	0.039	0.076	0.165	SMC...-4.0
	4.0SIR0.2M-Copy-1...	0.008	0.64	1.969	0.039	0.076		
	4.0SIR0.2L-Copy-1...	0.008	0.84	2.362	0.039	0.076		
6.0	6.0SIR0.2S-Copy-1...	0.008	0.36	1.417	0.051	0.115	0.276	SMC...-6.0
	6.0SIR0.2M-Copy-1...	0.008	0.64	1.969	0.051	0.115		
	6.0SIR0.2L-Copy-1...	0.008	0.84	2.362	0.051	0.115		

Micro Boring Chamfer

Internal

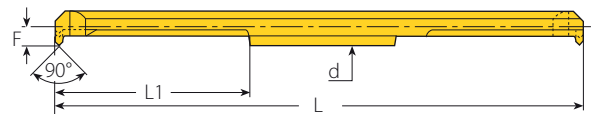
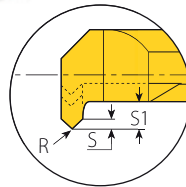
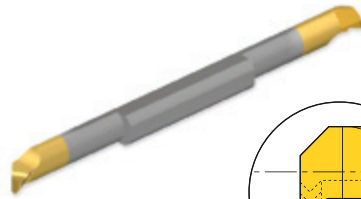
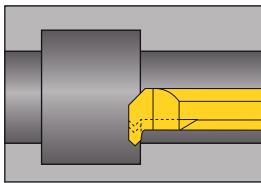

RH-Double Ended

Micro - Double Ended

Insert dia. d (mm)	Ordering Code RH	R	L1	L	F	S1	S	Min. Bore dia. inch	Holder
4.0	4.0SIR0.2S-Chamfer-0...	0.008	0.36	1.417	0.076	0.031	0.016	0.165	SMC...-4.0
	4.0SIR0.2M-Chamfer-0...	0.008	0.64	1.969	0.076	0.031	0.016		
	4.0SIR0.2L-Chamfer-0...	0.008	0.84	2.362	0.076	0.031	0.016		
6.0	6.0SIR0.2S-Chamfer-0...	0.008	0.36	1.417	0.115	0.039	0.028	0.244	SMC...-6.0
	6.0SIR0.2M-Chamfer-0...	0.008	0.64	1.969	0.115	0.039	0.028		
	6.0SIR0.2L-Chamfer-0...	0.008	0.84	2.362	0.115	0.039	0.028		

Micro Boring - Long Nose



Internal

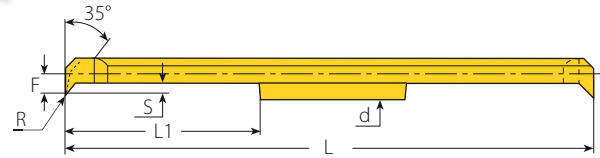
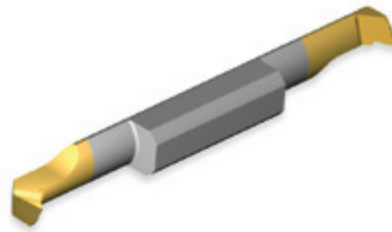
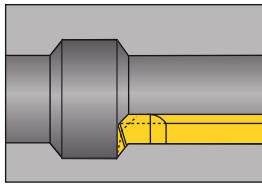

RH-Double Ended

Micro - Double Ended

Insert dia.	Ordering Code	Dimensions inch					Min. Bore dia.	Holder
d(mm)	RH	R	L1	L	F	S	inch	
6.0	6.0SIR0.2S-3527-1...	0.008	0.36	1.417	0.106	0.115	0.272	SMC...-6.0
	6.0SIR0.2M-3527-1...	0.008	0.64	1.969	0.106	0.115		
	6.0SIR0.2L-3527-1...	0.008	0.84	2.362	0.106	0.115		
8.0	8.0SIR0.2S-3537-1...	0.008	0.48	2.126	0.146	0.154	0.35	SMC...-8.0
	8.0SIR0.2M-3537-1...	0.008	0.79	2.756	0.146	0.154		
	8.0SIR0.2L-3537-1...	0.008	1.09	3.386	0.146	0.154		
10.0	10.0SIR0.2S-3547-1...	0.008	0.58	2.362	0.185	0.194	0.425	SMC...-10.0
	10.0SIR0.2M-3547-1...	0.008	0.99	3.150	0.185	0.194		
	10.0SIR0.2L-3547-1...	0.008	1.37	3.937	0.185	0.194		

Micro Boring - Back Edge



Internal

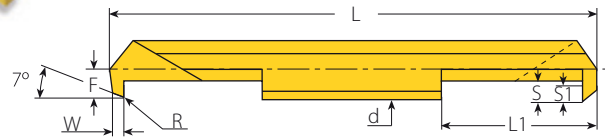
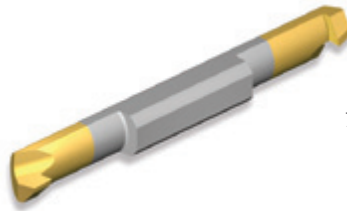
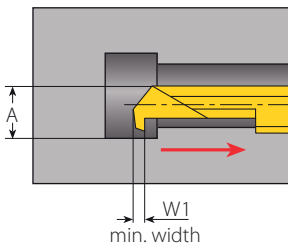

RH-Double Ended

Micro - Double Ended

Insert dia.	Ordering Code	Dimensions inch										Min. Bore dia.	Holder
d(mm)	RH	R	L1	L	A	W	W1	S	S1	F	inch		
3.0	3.0SIR0.2S-Back-1...	0.002	0.36	1.417	0.135	0.059	0.071	0.031	0.024	0.056	0.126	SMC...-3.0	
	3.0SIR0.2M-Back-1...	0.002	0.64	1.969									
4.0	4.0SIR0.2S-Back-1...	0.002	0.36	1.417	0.175	0.079	0.092	0.051	0.039	0.076	0.165	SMC...-4.0	
	4.0SIR0.2M-Back-1...	0.002	0.64	1.969									
	4.0SIR0.2L-Back-1...	0.002	0.84	2.362									
6.0	6.0SIR0.2S-Back-1...	0.002	0.36	1.417	0.254	0.079	0.097	0.075	0.063	0.115	0.244	SMC...-6.0	
	6.0SIR0.2M-Back-1...	0.002	0.64	1.969									
	6.0SIR0.2L-Back-1...	0.002	0.84	2.362									

Micro Boring - Bore Drill

Internal

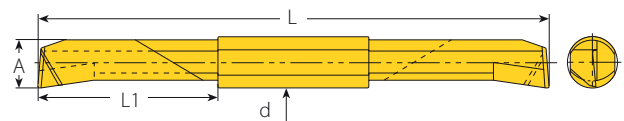
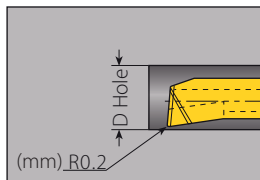

RH-Double Ended

Micro - Double Ended

Insert dia.	Ordering Code	Dimensions inch				Min. Bore dia.	Holder
d(mm)	RH	L1	L	A	inch		
4.0	4.0SIR0.2M-BD-1...	0.64	1.969	0.139	0.147	SMC...-4.0	
6.0	6.0SIR0.2M-BD-1...	0.64	1.969	0.205	0.228	SMC...-6.0	
	6.0SIR0.2L-BD-1...	0.84	2.362				
8.0	8.0SIR0.2S-BD-1...	0.48	2.126	0.272	0.307	SMC...-8.0	
	8.0SIR0.2M-BD-1...	0.79	2.756				
	8.0SIR0.2L-BD-1...	1.09	3.386				



Boring





> Toolholders

- VARDEX Ordering Code System.....Page 184
- Series A - Boring Bars for CD0W Inserts.....Page 185
- Series B - Boring Bars for TD0W Inserts.....Page 186
- Series E -Boring Bars for WC0W Inserts (4213, 4214).....Page 187
- Series F - Boring Bars for WC0W Inserts (5013, 5014).....Page 188
- Toolholders - Micro Double Ended.....Page 189

VarDEX Ordering Code System

PowerBore Toolholders

C	06	-	23	C	40	5
1	2		3	4	5	6
1 - Shank Style		2 - Shank Dia.		3 - Bar Dia. [Di]		4 - Insert Shape
C - Carbide S - Steel		05 - 5/32" - 0.156 06 - 3/16" - 0.187 08 - 1/4" - 0.250 10 - 5/16" - 0.312 12 - 3/8" - 0.375 16 - 1/2" - 0.500		21 - 0.165 23 - 0.180 24 - 0.187 26 - 0.203 32 - 0.250 40 - 0.312		C - Diamond 80 Deg.  T - Triangle  W - Trigon 80 Deg. 
						5 - Holder Length [L2]
						23 - 2.25 25 - 2.50 27 - 2.75 30 - 3.00 35 - 3.50 40 - 4.00 45 - 4.50 50 - 5.00 60 - 6.00
						6 - Front Relief Angle
						0, 5, 7

Micro

S	M	C	0625	-	3
1	2	3	4		5
1 - Holder Shape		2 - Holder Type		3 - Cooling	
S - Sleeve (Double Ended)		M - Micro (Double Ended)		C - Coolant Channel	
			4 - Holder Dia.		5 - Bore Size
			050 - 1/2" 0625 - 5/8" 075 - 3/4"		Micro Size 3, 4, 6, 8, 10

Series A - Boring Bars for CD0W Inserts

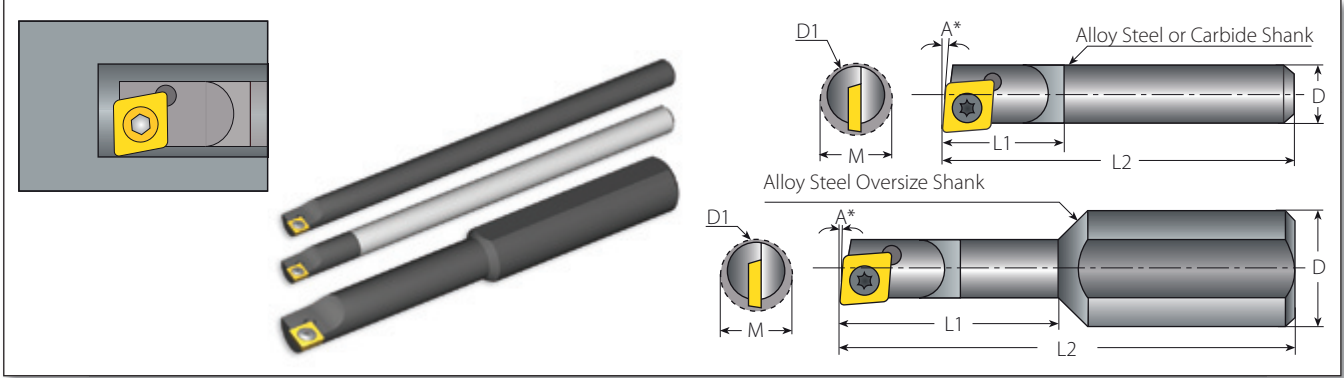

Alloy Steel Shanks - Standard Size

Shank	Ordering Code	EDP No.	Dimensions inch					L1	Insert Type	Screw	Torx Key
			A	D	D1	M	L2				
			angle	shank dia.	bar dia.	min.bore	overall length	bar length			
3/16"	S06-21C257	41546	7°	0.187	0.165	0.180	2.500	.500	CD0W	VS01	VT51
	S06-23C255	41547	5°	0.187	0.180	0.208	2.500				
	S06-24C255	41548	5°	0.187	0.187	0.230	2.500				
	S06-24C250	41543	0°	0.187	0.187	0.244	2.500				
1/4"	S08-32C305	41550	5°	0.250	0.250	0.290	3.000	D1=D			
	S08-32C300	41551	0°	0.250	0.250	0.300	3.000				



Solid Carbide Shank with Alloy Steel Head - Standard Size

Shank	Ordering Code	EDP No.	Dimensions inch					L1	Insert Type	Screw	Torx Key
			A	D	D1	M	L2				
			angle	shank dia.	bar dia.	min.bore	overall length	bar length			
5/32"	C05-21C607	41552	7°	.156	.165	.180	6.000	.500	CD0W	VS01	VT51
3/16"	C06-23C405	41553	5°	.187	.180	.208	4.000				
	C06-24C405	41554	5°	.187	.187	.230	4.000				
	C06-24C400	41555	0°	.187	.187	.244	4.000				
1/4"	C08-32C405	41556	5°	.250	.250	.290	4.000	D1=D			
	C08-32C400	41557	0°	.250	.250	.300	4.000				



Alloy Steel Shanks- Oversize

Shank	Ordering Code	EDP No.	Dimensions inch					L1	Insert Type	Screw	Torx Key
			A	D	D1	M	L2				
			angle	shank dia.	bar dia.	min.bore	overall length	bar length			
3/8"	S12-23C235	41558	5°	.375	.180	.208	2.250	1.000	CD0W	VS01	VT51
	S12-26C235	41559	5°	.375	.203	.230	2.250				
	S12-26C230	41560	0°	.375	.203	.244	2.250				
	S12-32C255	41561	5°	.375	.250	.290	2.500	1.250			
	S12-32C250	41562	0°	.375	.250	.300	2.500				

* 5° angle for facing and thru-hole boring
 * 0° angle for thru-hole boring and boring to a shoulder

Series B - Boring Bars for TD0W Inserts

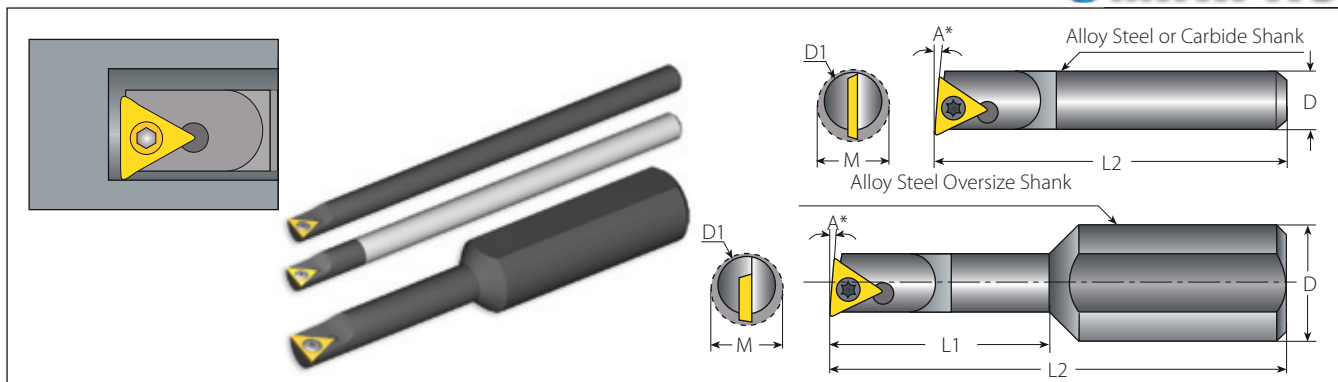

Alloy Steel Shanks - Standard Size

Spare Parts

Shank	Ordering Code	EDP No.	Dimensions inch				Insert Type	Screw	Torx Key
			A angle	D=D1 bar dia.	M min.bore	L2 overall length			
3/16"	S06-24T355	41563	5°	.187	.270	3.500	TD0W	VS01	VT51
	S06-24T350	41564	0°	.187	.270	3.500			
1/4"	S08-32T405	41565	5°	.250	.300	4.000		VS40	
	S08-32T400	41566	0°	.250	.300	4.000			
5/16"	S10-40T405	41567	5°	.312	.360	4.000		VS40	
	S10-40T400	41568	0°	.312	.360	4.000			



Solid Carbide Shank with Alloy Steel Head - Standard Size

Spare Parts

Shank	Ordering Code	EDP No.	Dimensions inch				Insert Type	Screw	Torx Key
			A angle	D=D1 bar dia.	M min.bore	L2 overall length			
3/16"	C06-24T405	41569	5°	.187	.270	4.000	TD0W	VS01	VT51
	C06-24T400	41570	0°	.187	.270	4.000			
1/4"	C08-32T405	41571	5°	.250	.300	4.000		VS40	
	C08-32T400	41572	0°	.250	.300	4.000			
5/16"	C10-40T405	41573	5°	.312	.360	4.000		VS40	
	C10-40T400	41574	0°	.312	.360	4.000			



Alloy Steel Shanks - Oversize

Spare Parts

Shank	Ordering Code	EDP No.	Dimensions inch							Insert Type	Screw	Torx Key
			A angle	shank dia.	D bar dia.	D1 bar dia.	M min.bore	L2 overall length	L1 bar length			
3/8"	S12-26T255	41575	5°	.375	.203	.270	2.500	1.000	TD0W	VS01	VT51	
	S12-26T250	41576	0°	.375	.203	.270	2.500	1.000				
	S12-32T275	41577	5°	.375	.250	.300	2.750	1.250		VS40		
	S12-32T270	41578	0°	.375	.250	.300	2.750	1.250				
	S12-40T305	41579	5°	.375	.312	.360	3.000	1.500		VS40		
	S12-40T300	41580	0°	.375	.312	.360	3.000	1.500				

Series E - Boring Bars for WC0W Inserts (4213, 4214)

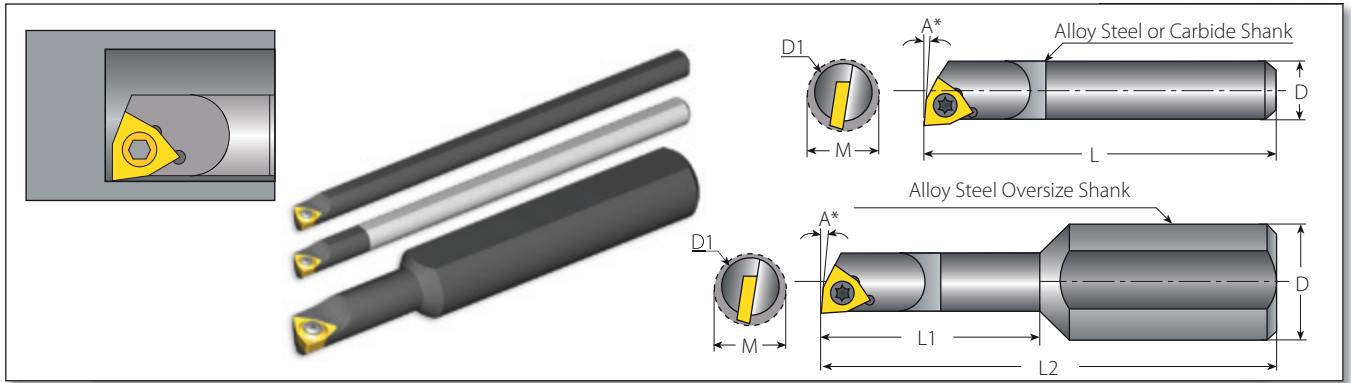

Spare Parts

Alloy Steel Shanks - Standard Size

Shank	Ordering Code	EDP No.	Dimensions inch				Insert Type	Screw	Torx Key
			A angle	D=D1 bar dia.	M min.bore	L bar length			
3/16"	S06-24W255	41581	5°	.187	.230	2.500	WC0W4213 WC0W4214	VS40	VT51
	S06-24W250	41582	0°	.187	.244	2.500			
1/4"	S08-32W405	41583	5°	.250	.300	4.000			
	S08-32W400	41584	0°	.250	.300	4.000			



Spare Parts

Solid Carbide Shank with Alloy Steel Head - Standard Size

Shank	Ordering Code	EDP No.	Dimensions inch				Insert Type	Screw	Torx Key
			A angle	D=D1 bar dia.	M min.bore	L bar length			
3/16"	C06-24W405	41585	5°	.187	.230	4.000	WC0W4213 WC0W4214	VS40	VT51
	C06-24W400	41586	0°	.187	.244	4.000			
1/4"	C08-32W405	41587	5°	.250	.290	4.000			
	C08-32W400	41588	0°	.250	.300	4.000			



Spare Parts

Alloy Steel Shanks - Oversize

Shank	Ordering Code	EDP No.	Dimensions inch					Insert Type	Screw	Torx Key
			A angle	D shank dia.	D1 bar dia.	M min.bore	L2 overall length			
3/8"	S12-26W235	41589	5°	.375	.203	.230	2.250	WC0W4213 WC0W4214	VS40	VT51
	S12-26W230	41590	0°	.375	.203	.244	2.250			
	S12-32W255	41591	5°	.375	.250	.290	2.500			
	S12-32W250	41592	0°	.375	.250	.300	2.500			

* 5° angle for facing and thru-hole boring
 * 0° angle for thru-hole boring and boring to a shoulder

Series F - Boring Bars for WCOW Inserts (5013, 5014)

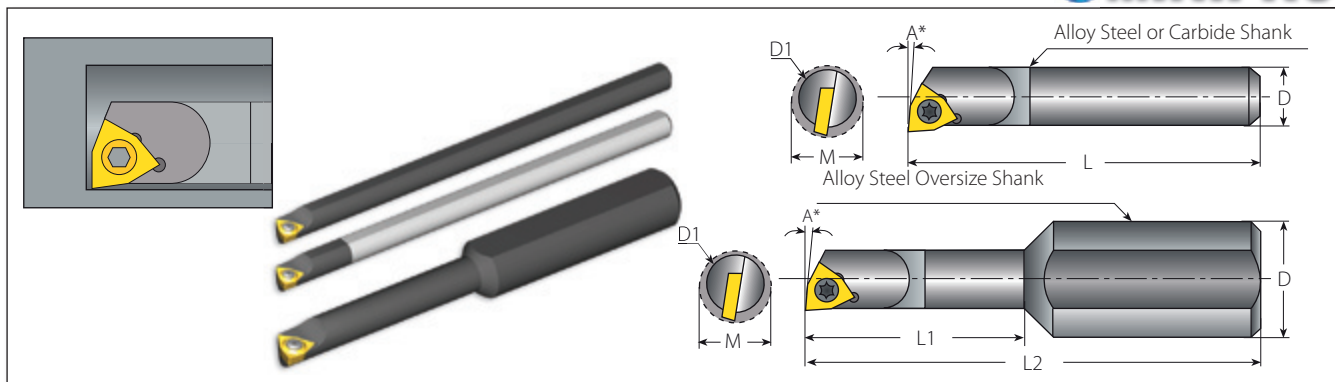

Alloy Steel Shanks - Standard Size

Spare Parts

Shank	Ordering Code	EDP No.	Dimensions inch				Insert Type	Screw	Torx Key
			A	D=D1	M	L			
			angle	bar dia.	min.bore	bar length			
5/16"	S10-40W405	41593	5°	.312	.360	4.000	WCOW5013	VS41	VT51
	S10-40W400	41594	0°	.312	.360	4.000	WCOW5014		



Solid Carbide Shank with Alloy Steel Head - Standard Size

Spare Parts

Shank	Ordering Code	EDP No.	Dimensions inch				Insert Type	Screw	Torx Key
			A	D=D1	M	L			
			angle	bar dia.	min.bore	bar length			
5/16"	C10-40W405	41597	5°	.312	.360	4.000	WCOW5013	VS41	VT51
	C10-40W400	41598	0°	.312	.360	4.000	WCOW5014		



Alloy Steel Shanks - Oversize

Spare Parts

Shank	Ordering Code	EDP No.	Dimensions inch						Insert Type	Screw	Torx Key
			A	D	D1	M	L2	L1			
			angle	shank dia.	bar dia.	min.bore	overall length	bar length			
3/8"	S12-40W305	41599	5°	.375	.312	.360	3.000	1.500	WCOW5013	VS41	VT51
	S12-40W300	41600	0°	.375	.312	.360	3.000	1.500	WCOW5014		

Internal Toolholders

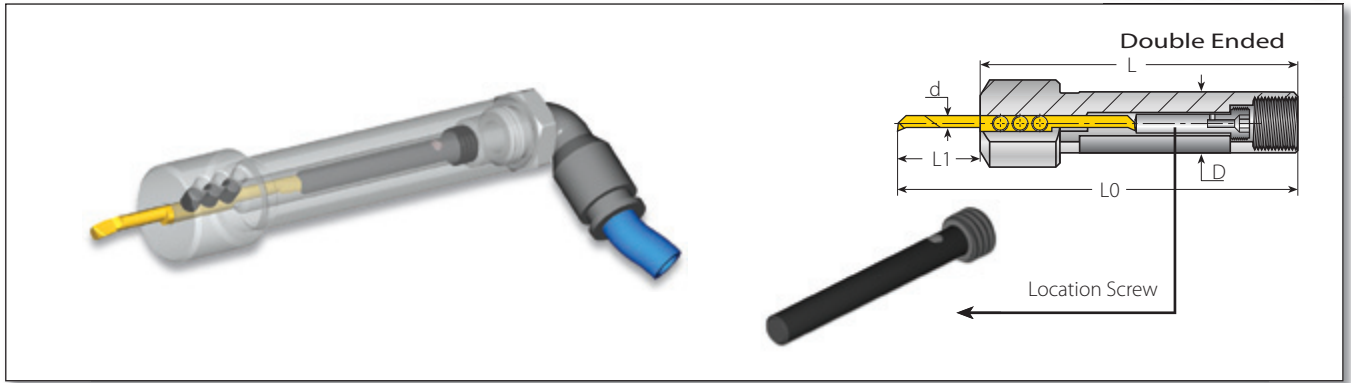

Micro - Double Ended

Spare Parts



Micro Insert Dia.	Shank Dia.	Ordering Code	EDP No.	Dimensions inch			Location Screw*			Clamping Screw x 3	
				L	L1	L0	Screw	M	Key	Screw	Key
3	0.50	SMC050-3.0	41075	3.15	0.35- Short	3.50	4GISM8X28	1.10	K4.0	M4X0.7X4.0	K2.0
					0.63- Medium	3.78					
	3.74	0.35- Short	4.09	4GISM8X49	1.93						
		0.63- Medium	4.37	4GISM8X42	1.65						
4	0.50	SMC050-4.0	41092	3.15	0.35- Short	3.50	4GISM8X28	1.10			
					0.63- Medium	3.78	4GISM8X21	0.83			
					0.83- Long	3.98	4GISM8X16	0.63			
	3.74	SMC0625-4.0	40212	0.35- Short	4.09	4GISM8X49	1.93				
				0.63- Medium	4.37	4GISM8X42	1.65				
				0.83- Long	4.57	4GISM8X37	1.46				
6	0.50	SMC050-6.0	41517	3.15	0.35- Short	3.50	4GISM8X28	1.10			
					0.63- Medium	3.78	4GISM8X21	0.83			
					0.83- Long	3.98	4GISM8X16	0.63			
	3.74	SMC0625-6.0	40214	0.35- Short	4.09	4GISM8X49	1.93				
				0.63- Medium	4.37	4GISM8X42	1.65				
				0.83- Long	4.57	4GISM8X37	1.46				
8	0.63	SMC0625-8.0	40248	3.74	0.47 - Short	4.21	4GISM8X33	1.30			
					0.79 - Medium	4.53	4GISM8X25	0.98			
	0.79	SMC075-8.0	40184		1.10 - Long	4.84	4GISM8X17	0.67			
10	0.63	SMC0625-10.0	41093	3.74	0.59 - Short	4.33	4GISM8X30	1.18			
					0.98 - Medium	4.72	4GISM8X20	0.79			
	0.79	SMC075-10.0	41083		1.38 - Long	5.12	4GISM8X10	0.39			

* Every toolholder package contains the full range of location screws needed.

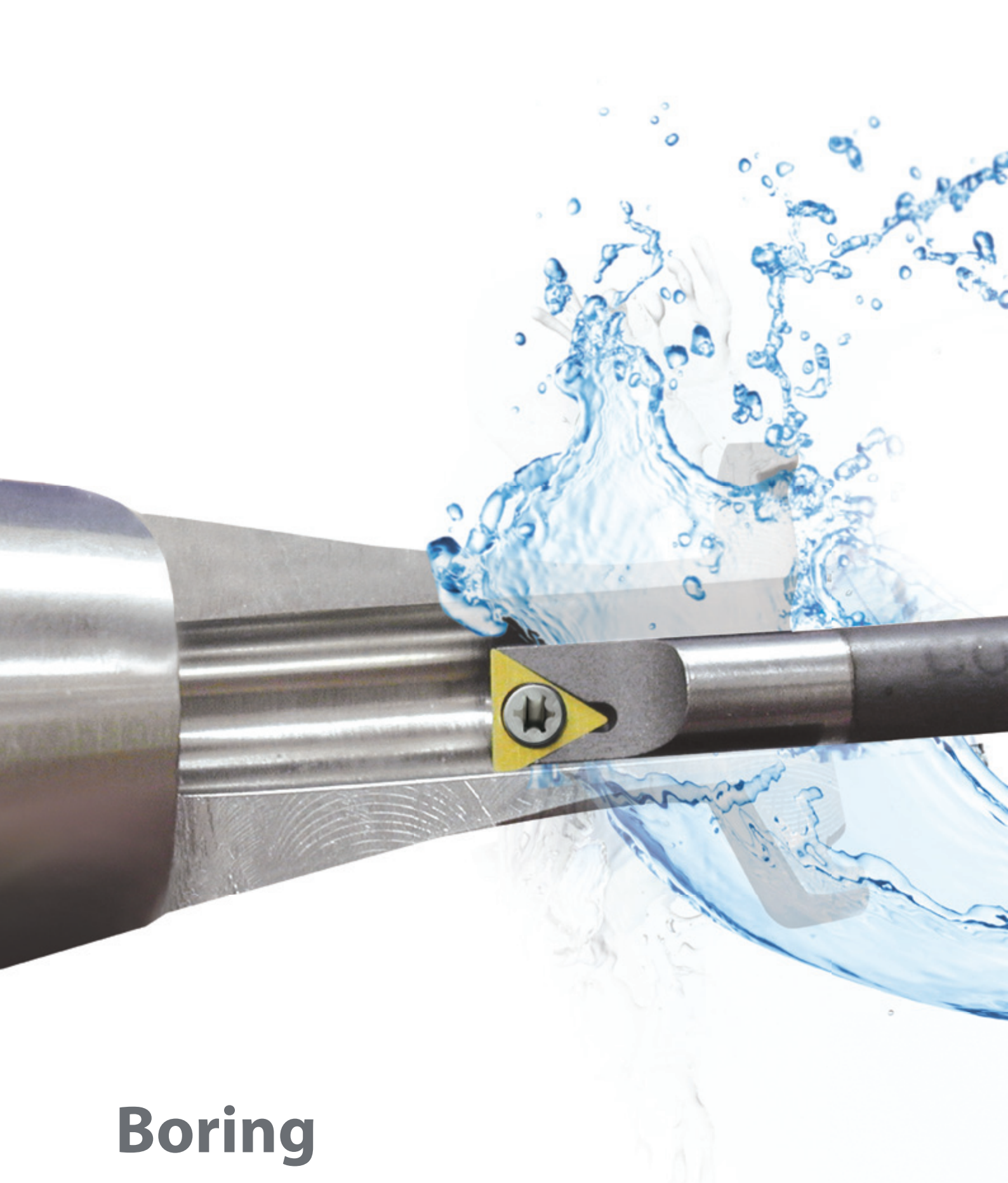

Boring

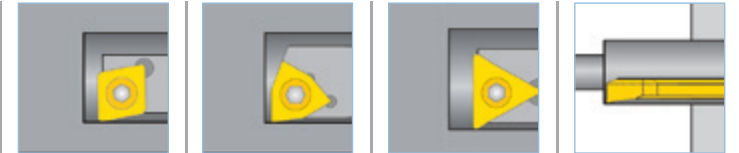





> Technical Data



- Spare Parts PowerBorePage 192
- Recommended Cutting Data - PowerBore and Micro.....Page 193
- Grades and Their Applications.....Page 193

Spare Parts PowerBore

Spare Parts PowerBore					
Insert	Boring Bar	Insert	Torx Screw	Screw Description	Torx key
	A	CD0W	VS01	1-72 Oval X 0.109LG.	VT51
	B	TD0W Min. Bore 0.28 > Bore 0.28	VS01 VS40	1-72 Oval X 0.109LG. M2 X 0.4 X 0.152LG.	
	E	WC0W4213, WC0W4214	VS40	M2 X 0.4 X 0.152LG.	
	F	WC0W5013, WC0W5014	VS41	M2 X 0.4 X 0.193LG.	

Recommended Grades, Cutting Speeds Vc [ft/min], Feed f [inch/rev] and Max Depth [inch]



Material Group	Vardex No.	Material	Hardness Brinell HB	Vc [ft/min]		Feed f [inch/rev]		Max Depth [inch]				
				Coated		Power Bore	Micro	PowerBore			Micro	
				VTX (PowerBore)	VMX (Micro)			CD0W	TD0W	WD0W		
P Steel	1	Unalloyed steel	Low carbon (C=0.1-0.25%)	125	377 - 623	164 - 393	0.0098	0.002	0.020	0.018	0.024	0.016
	2		Medium carbon (C=0.25-0.55%)	150	328 - 574	131 - 328	0.0079	0.0016	0.020	0.018	0.024	0.016
	3		High Carbon (C=0.55-0.85%)	170	295 - 541	98 - 262	0.0059	0.0012	0.020	0.018	0.024	0.016
	4	Low alloy steel (alloying elements ≤5%)	Non hardened	180	279 - 475	164 - 229	0.0079	0.0016	0.016	0.014	0.020	0.012
	5		Hardened	275	246 - 459	131 - 197	0.0059	0.0016	0.016	0.014	0.020	0.012
	6		Hardened	350	229 - 443	98 - 164	0.0039	0.0012	0.016	0.014	0.020	0.012
	7	High alloy steel (alloying elements >5%)	Annealed	200	229 - 361	98 - 164	0.0039	0.0016	0.008	0.007	0.016	0.006
	8		Hardened	325	164 - 328	82 - 131	0.002	0.0012	0.008	0.007	0.016	0.006
	9	Cast steel	Low alloy (alloying elements <5%)	200	246 - 459	98 - 164	0.0098	0.0016	0.008	0.007	0.016	0.006
	10		High alloy (alloying elements >5%)	225	197 - 393	82 - 131	0.0039	0.0016	0.008	0.007	0.016	0.006
M Stainless Steel	11	Stainless steel	Non hardened	200	229 - 426	197 - 328	0.0079	0.0016	0.010	0.009	0.020	0.008
	12	Feritic	Hardened	330	197 - 377	131 - 197	0.0031	0.0012	0.008	0.007	0.016	0.006
	13	Stainless steel	Austenitic	180	295 - 459	164 - 295	0.0079	0.0016	0.010	0.009	0.020	0.008
	14	Austenitic	Super Austenitic	200	131 - 361	131 - 197	0.0031	0.0016	0.008	0.007	0.016	0.006
	15	Stainless steel	Non hardened	200	295 - 393	131 - 197	0.0079	0.0016	0.010	0.009	0.020	0.008
	16	Cast feritic	Hardened	330	213 - 361	98 - 164	0.0031	0.0012	0.008	0.007	0.016	0.006
	17	Stainless steel	Austenitic	200	279 - 361	131 - 197	0.0079	0.0016	0.010	0.009	0.020	0.008
	18	Cast austenitic	Hardened	330	197 - 328	98 - 164	0.0031	0.0012	0.008	0.007	0.016	0.006
K Cast Iron	28	Malleable	Ferritic (short chips)	130	229 - 524	164 - 229	0.0059	0.0008	0.012	0.012	0.016	0.010
	29	Cast iron	Pearlitic (long chips)	230	197 - 475	164 - 229	0.0039	0.0004	0.012	0.012	0.016	0.010
	30	Grey	Low tensile strength	180	229 - 426	164 - 229	0.0059	0.0008	0.020	0.018	0.024	0.016
	31	Cast iron	High tensile strength	260	197 - 377	131 - 197	0.0039	0.0004	0.020	0.018	0.024	0.016
	32	Nodular SG iron	Ferritic	160	410 - 524	164 - 229	0.0059	0.0008	0.020	0.018	0.024	0.016
33	Pearlitic		260	295 - 393	197 - 262	0.0039	0.0004	0.020	0.018	0.024	0.016	
N(K) Non-Ferrous Metals	34	Wrought	Non aging	60	328 - 1,196	328 - 983	0.0118	0.0012	0.030	0.025	0.039	0.020
	35	Aluminium alloys	Aged	100	262 - 721	328 - 492	0.0079	0.0012	0.030	0.025	0.039	0.020
	36	Aluminium alloys	Cast	75	656 - 1,311	328 - 492	0.0118	0.0012	0.030	0.025	0.039	0.020
	37		Cast & aged	90	656 - 918	197 - 328	0.0079	0.0012	0.030	0.025	0.039	0.020
	38		Cast Si 13-22%	130	197 - 590	328 - 492	0.0118	0.0008	0.030	0.025	0.039	0.020
	39	Copper and copper alloys	Brass	90	262 - 738	197 - 328	0.0118	0.0012	0.030	0.025	0.039	0.020
40	Bronze and non leaded copper		100	262 - 836	197 - 328	0.0079	0.0012	0.030	0.025	0.039	0.020	
S(M) Heat Resistant Material	19	High temperature alloys	Annealed (Iron based)	200	148 - 197	82 - 148	0.0079	0.0016	0.010	0.009	0.020	0.008
	20		Aged (Iron based)	280	98 - 164	66 - 98	0.0031	0.0012	0.008	0.007	0.016	0.006
	21		Annealed (Nickel or Cobalt based)	250	66 - 98	49 - 66	0.0031	0.0004	0.008	0.007	0.016	0.006
	22		Aged (Nickel or Cobalt based)	350	49 - 82	33 - 49	0.002	0.0004	0.008	0.007	0.016	0.006
	23	Titanium alloys	Pure 99.5 Ti	400Rm	459 - 557	197 - 328	0.002	0.0008	0.008	0.007	0.016	0.006
24	α+β alloys		1050Rm	164 - 229	131 - 164	0.002	0.0008	0.008	0.007	0.016	0.006	
H(K) Hardened Material	25	Extra hard steel	Hardened & tempered	45-50HRC	148 - 213	66 - 148	0.0008	0.0004	0.004	0.002	0.008	0.002
	26			51-55HRC	148 - 197	66 - 131	0.0004	0.0004	0.002	0.002	0.004	0.002

Grades and Their Applications

VTX

General use carbide grade.
TiAlN coated.

VMX

General use carbide grade
for Micro inserts. TiN coated

