



▶ REDLINE

Comprehensive Line of
Thick Threading Inserts



INCH



Comprehensive line of thick threading inserts

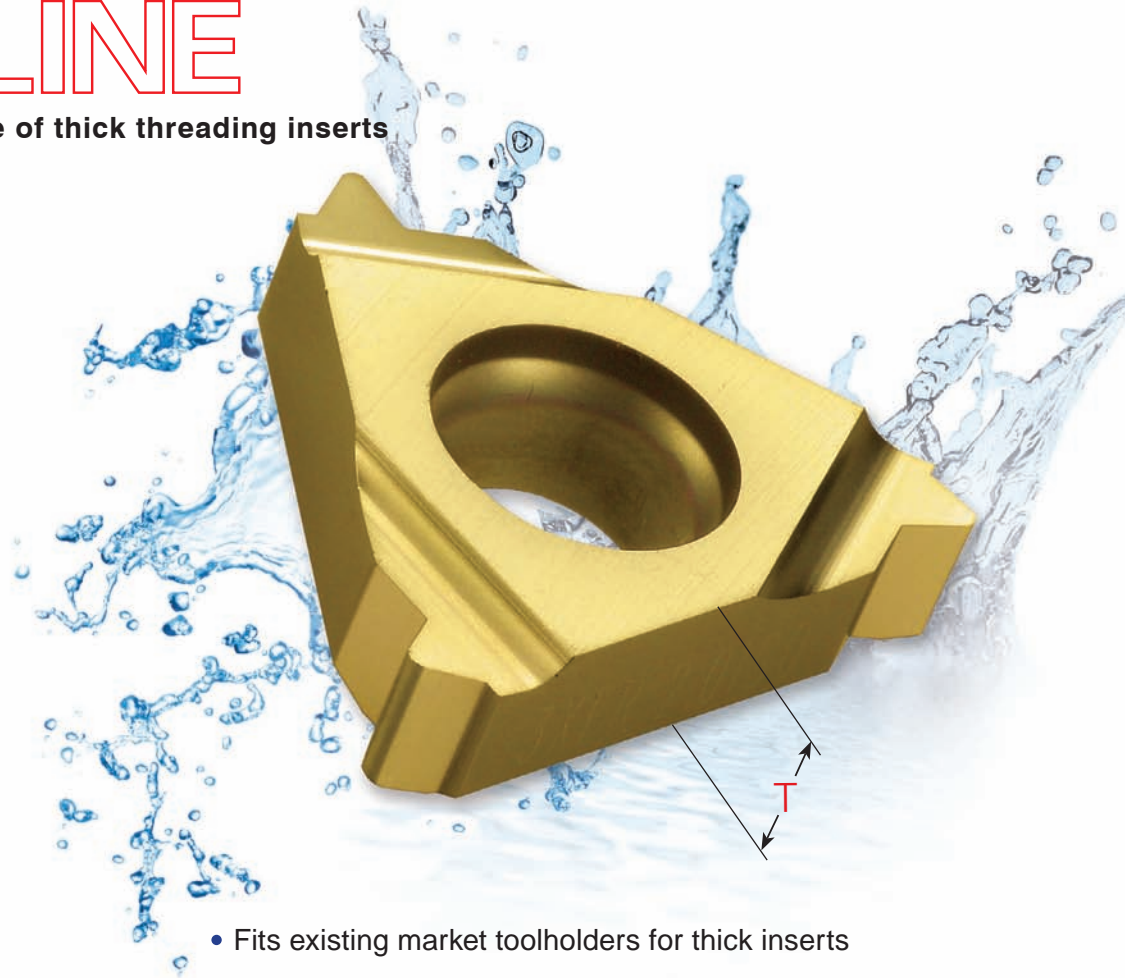

- Fits existing market toolholders for thick inserts
- Does not require tool replacement
- Produced in VKX, the superior grade for general use



Redline Insert Thickness (T)

I.C.	L	T - Standard	T - Redline
1/4"	.43"	.125"	.133"
3/8"	.63"	.142"	.169"
1/2"	.87"	.187"	.232"

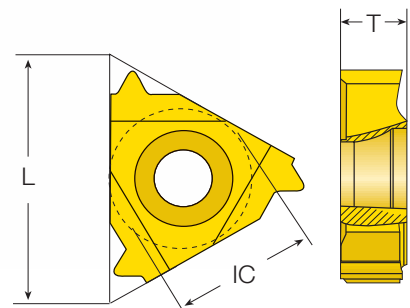

REDLINE CATALOG

INSERTS

■ Partial Profile 60°	Page 4
■ Partial Profile 55°	Page 4
■ American UN	Page 5
■ ISO Metric	Page 6
■ Whitworth for BSW, BSP	Page 7
■ BSPT	Page 7
■ NPT	Page 8
■ Round (DIN 405)	Page 8
■ Trapez	Page 9
■ American ACME	Page 9
■ Stub ACME	Page 10
■ UNJ	Page 10
■ American Buttress	Page 11
■ API	Page 11
■ API Buttress Casing	Page 12
■ API Round Casing & Tubing	Page 12

TOOLHOLDERS

■ External	Page 13
■ Internal	Page 13

TECHNICAL DATA

■ Helix angle and Anvil selection	Page 14
■ API Standard Drawings	Page 15
■ Cutting Data	Page 16



TT Gen Software and updated versions can be downloaded from www.vargususa.com

Partial Profile 60°

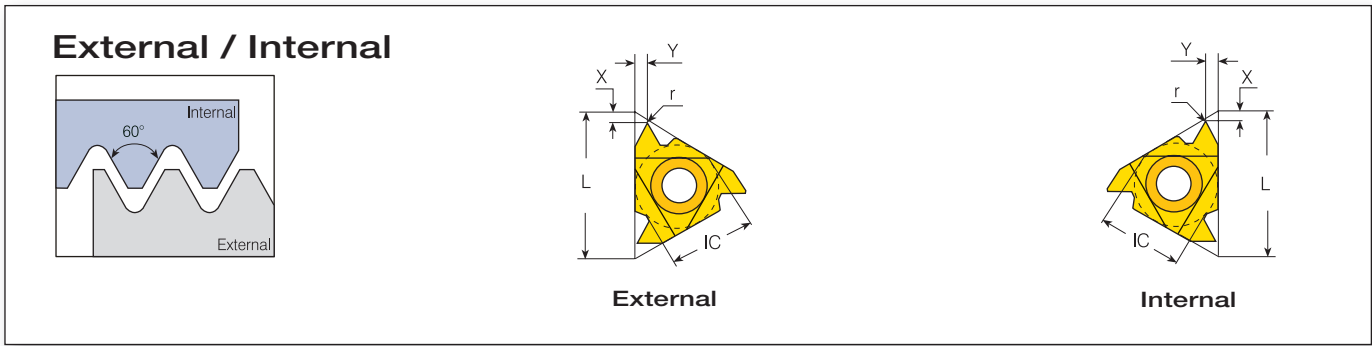

	Insert Size		Pitch		Ordering Code	EDP No.	Dimensions inch			Anvil				
	IC	L inch	mm	tpi	RH	VKX	r	X	Y	RH	Toolholder			
	External	3/8"	.63	0.5-1.5	48-16	3XERA60...	54383	.002	.04	.04	YE3	AL...-3X		
				1.75-3.0	14-8	3XERG60...	54384	.011	.04	.06				
				0.5-3.0	48-8	3XERAG60...	54372	.003	.05	.07				
	Internal	1/4"	.43	0.5-1.5	48-16	2XIRA60...	54386	.002	.03	.04	-	NVR...-2X		
				0.5-1.5	48-16	3XIRA60...	54387	.002	.04	.04				
				3/8"	.63	1.75-3.0	14-8	3XIRG60...	54388	.006	.04	.06	YI3	AVR...-3X
						0.5-3.0	48-8	3XIRAG60...	54389	.002	.05	.06		
				1/2"	.87	3.5-6.0	7-5	4XIRP60...	54390	.012	.03	.10	YI4	AVR...-4X

Partial Profile 55°

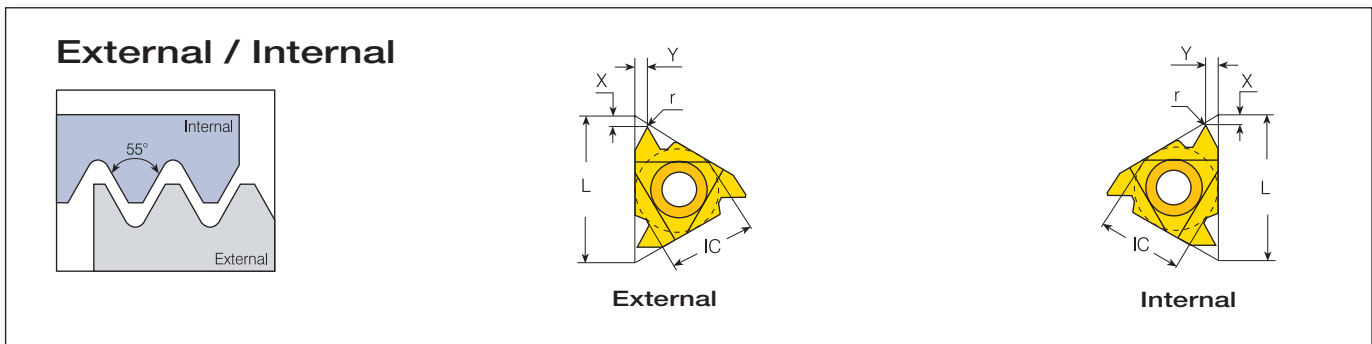

	Insert Size		Pitch		Ordering Code	EDP No.	Dimensions inch			Anvil				
	IC	L inch	mm	tpi	RH	VKX	r	X	Y	RH	Toolholder			
	External	3/8"	.63	0.5-1.5	48-16	3XERA55...	54391	.002	.04	.04	YE3	AL...-3X		
				1.75-3.0	14-8	3XERG55...	54392	.008	.04	.06				
				0.5-3.0	48-8	3XERAG55...	54393	.003	.04	.07				
	Internal	1/4"	.43	0.5-1.5	48-16	2XIRA55...	54395	.002	.03	.04	-	NVR...-2X		
				3/8"	.63	0.5-1.5	48-16	3XIRA55...	54396	.002	.04	.04		
						1.75-3.0	14-8	3XIRG55...	54397	.008	.04	.06	YI3	AVR...-3X
						0.5-3.0	48-8	3XIRAG55...	54398	.003	.04	.07		
				1/2"	.87	3.5-6.0	7-4	4XIRP55...	54399	.017	.01	.11	YI4	AVR...-4X

American UN

External / Internal

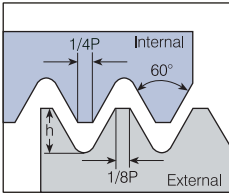

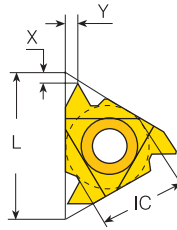

Defined by: ANSI B1.1:74
Tolerance class: 2A/2B

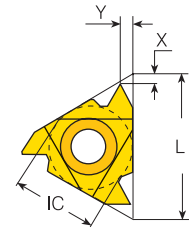

External



Internal

	Insert Size		Pitch	Ordering Code	EDP No.	Dimensions inch			Anvil		
	IC	L inch	tpi	RH	VKX	h min	X	Y	RH	Toolholder	
	External	3/8"	.63	32	3XER32UN...	54379	.019	.05	.02	YE3	AL...-3X
				28	3XER28UN...	54380	.022	.05	.03		
				24	3XER24UN...	54433	.026	.05	.03		
				20	3XER20UN...	54381	.031	.05	.03		
				18	3XER18UN...	54375	.034	.05	.04		
				16	3XER16UN...	54374	.038	.05	.04		
				14	3XER14UN...	54382	.044	.05	.05		
				13	3XER13UN...	54448	.047	.05	.06		
				12	3XER12UN...	54373	.051	.05	.06		
	Internal	1/4"	.43	32	2XIR32UN...	54435	.018	.03	.02	-	NVR...-2X
				28	2XIR28UN...	54436	.020	.03	.03		
				24	2XIR24UN...	54437	.024	.03	.03		
				20	2XIR20UN...	54438	.029	.03	.04		
				18	2XIR18UN...	54439	.032	.03	.04		
				16	2XIR16UN...	54440	.036	.03	.04		
		3/8"	.63	14	2XIR14UN...	54441	.041	.03	.04		
				20	3XIR20UN...	54442	.029	.05	.03		
				18	3XIR18UN...	54443	.032	.05	.04		
				16	3XIR16UN...	54444	.036	.05	.04		
				14	3XIR14UN...	54445	.041	.05	.05		
				13	3XIR13UN...	54449	.044	.05	.06		
				12	3XIR12UN...	54446	.048	.05	.06		
				8	3XIR8UN...	54447	.072	.05	.06		

ISO Metric

External / Internal

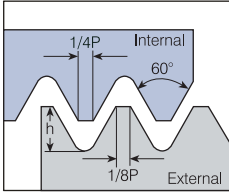

Defined by: R262 (DIN 13)
Tolerance class: 6g/6H

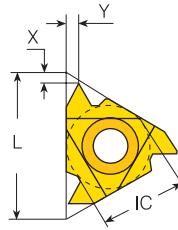

External

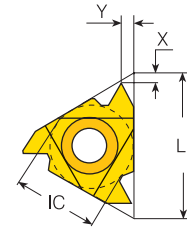

Internal



External



Internal

Insert Size		Pitch	Ordering Code	EDP No.	Dimensions inch			Anvil		
IC	L inch	mm	RH	VKX	h min	X	Y	RH	Toolholder	
3/8"	.63	0.5	3XER0.5ISO...	54400	.012	.05	.02			
		0.75	3XER0.75ISO...	54401	.018	.05	.02			
		0.8	3XER0.8ISO...	54402	.019	.05	.02			
		1.0	3XER1.0ISO...	54403	.024	.05	.03			
		1.25	3XER1.25ISO...	54404	.030	.05	.03		YE3	AL...-3X
		1.5	3XER1.5ISO...	54405	.036	.05	.04			
		1.75	3XER1.75ISO...	54406	.042	.05	.05			
		2.0	3XER2.0ISO...	54407	.048	.05	.06			
		2.5	3XER2.5ISO...	54408	.060	.05	.06			
		3.0	3XER3.0ISO...	54409	.072	.05	.07			
		3.5	4XER3.5ISO...	54410	.085	.07	.09			
		4.0	4XER4.0ISO...	54411	.096	.07	.09		YE4	AL...-4X
		4.5	4XER4.5ISO...	54412	.109	.07	.09			
		5.0	4XER5.0ISO...	54413	.121	.05	.10			
6.0	4XER6.0ISO...	54414	.145	.03	.11					
1/4"	.43	0.5	2XIR0.5ISO...	54415	.011	.03	.02			
		0.75	2XIR0.75ISO...	54416	.017	.03	.02			
		1.0	2XIR1.0ISO...	54417	.023	.03	.03		-	NVR...-2X
		1.5	2XIR1.5ISO...	54418	.034	.03	.04			
		2.0	2XIR2.0ISO...	54419	.045	.03	.04			
		0.75	3XIR0.75ISO...	54420	.017	.05	.02			
		1.0	3XIR1.0ISO...	54421	.023	.05	.03			
		1.25	3XIR1.25ISO...	54422	.028	.05	.03			
		1.5	3XIR1.5ISO...	54423	.034	.05	.04		YI3	AVR...-3X
		1.75	3XIR1.75ISO...	54424	.040	.05	.05			
2.0	3XIR2.0ISO...	54425	.045	.05	.06					
2.5	3XIR2.5ISO...	54426	.057	.05	.06					
3.0	3XIR3.0ISO...	54427	.068	.05	.07					
1/2"	.87	3.5	4XIR3.5ISO...	54428	.080	.06	.09			
		4.0	4XIR4.0ISO...	54429	.091	.06	.09			
		4.5	4XIR4.5ISO...	54430	.102	.06	.09		YI4	AVR...-4X
		5.0	4XIR5.0ISO...	54431	.114	.05	.10			
		6.0	4XIR6.0ISO...	54432	.136	.03	.09			

Whitworth - BSW, BSP, BSF, BSB

External / Internal

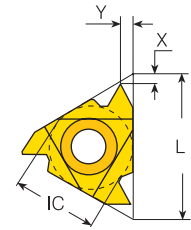
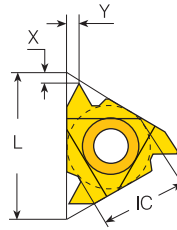
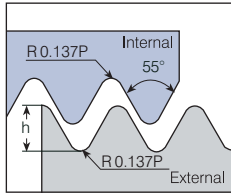

Defined by: B.S.84:1956, DIN 259, ISO228/1:1982
Tolerance class: Medium class A

External

Internal

	Insert Size		Pitch	Ordering Code	EDP No.	Dimensions inch			Anvil		
	IC	L inch	tpi	RH	VKX	h min	X	Y	RH	Toolholder	
	External	3/8"	.63	28	3XER28W...	54450	.023	.05	.03	YE3	AL...-3X
				19	3XER19W...	54378	.034	.05	.03		
				16	3XER16W...	54451	.040	.05	.04		
				14	3XER14W...	54452	.046	.05	.06		
	Internal	1/4"	.43	19	2XIR19W...	54453	.034	.03	.04	-	NVR...-2X
				14	2XIR14W...	54454	.046	.03	.04		
		3/8"	.63	16	3XIR16W...	54455	.040	.05	.04	YI3	AVR...-3X
				14	3XIR14W...	54456	.046	.05	.05		
				11	3XIR11W...	54457	.058	.05	.06		

BSPT

External / Internal

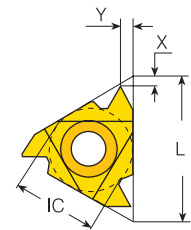
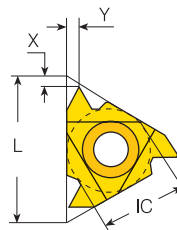
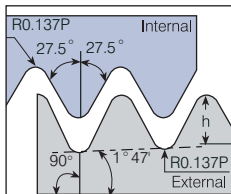

Defined by: B.S. 21:1985
Tolerance class: Standard BSPT

External

Internal

	Insert Size		Pitch	Ordering Code	EDP No.	Dimensions inch			Anvil		
	IC	L inch	tpi	RH	VKX	h min	X	Y	RH	Toolholder	
	External	3/8"	.63	19	3XER19BSPT...	54458	.034	.05	.03	YE3	AL...-3X
				14	3XER14BSPT...	54459	.046	.05	.05		
				11	3XER11BSPT...	54460	.058	.05	.06		
	Internal	1/4"	.43	19	2XIR19BSPT...	54461	.034	.03	.03	-	NVR...-2X
				14	2XIR14BSPT...	54462	.046	.03	.04		
		3/8"	.63	14	3XIR14BSPT...	54463	.046	.05	.05	YI3	AVR...-3X
				11	3XIR11BSPT...	54464	.058	.05	.06		

NPT

External / Internal

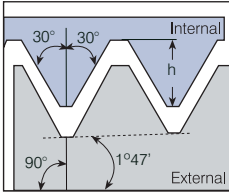

Defined by: USAS B2.1:1968
Tolerance class: Standard NPT

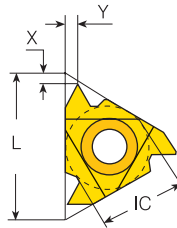

External

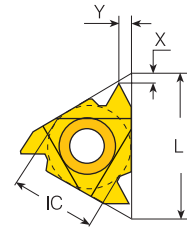

Internal

	Insert Size		Pitch	Ordering Code	EDP No.	Dimensions inch			Anvil	
	IC	L inch	tpi	RH	VKX	h min	X	Y	RH	Toolholder
 External	3/8"	.63	27	3XER27NPT...	54465	.026	.04	.03	YE3	AL...-3X
			18	3XER18NPT...	54466	.040	.04	.04		
			14	3XER14NPT...	54377	.052	.04	.05		
			11.5	3XER11.5NPT...	54371	.065	.04	.06		
			8	3XER8NPT...	54376	.095	.04	.06		
 Internal	1/4"	.43	18	2XIR18NPT...	54467	.040	.03	.03	-	NVR...-2X
			14	2XIR14NPT...	54468	.052	.03	.04		
	3/8"	.63	14	3XIR14NPT...	54469	.052	.04	.05	Y13	AVR...-3X
			11.5	3XIR11.5NPT...	54470	.065	.04	.06		
			8	3XIR8NPT...	54471	.095	.04	.06		

Round (DIN 405)

External / Internal

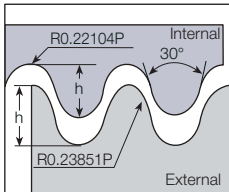

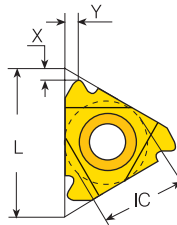

Defined by: DIN 405
Tolerance class: 7h/7H

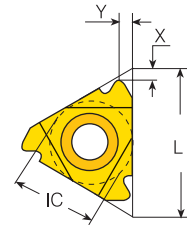

External



Internal

	Insert Size		Pitch	Ordering Code	EDP No.	Dimensions inch			Anvil	
	IC	L inch	tpi	RH	VKX	h min	X	Y	RH	Toolholder
 External	3/8"	.63	6	3XER6RD...	54472	.083	.06	.06	YE3	AL...-3X
			4	4XER4RD...	54473	.125	.08	.08		
 Internal	3/8"	.63	6	3XIR6RD...	54474	.083	.06	.06	Y13	AVR...-3X
			4	4XIR4RD...	54475	.125	.09	.09		

Trapez

External / Internal

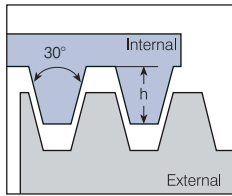

Defined by: DIN 103
Tolerance class: 7e/7H

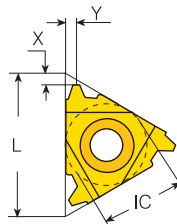

External

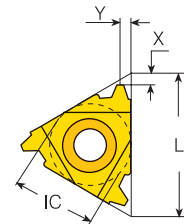

Internal

	Insert Size		Pitch	Ordering Code	EDP No.	Dimensions inch			Anvil	
	IC	L inch	mm	RH	VKX	h min	X	Y	RH	Toolholder
 External	3/8"	.63	2.0	3XER2.0TR...	54476	.049	.05	.04	YE3	AL...-3X
			3.0	3XER3.0TR...	54477	.069	.05	.05		
	1/2"	.87	4.0	4XER4.0TR...	54478	.089	.06	.10	YE4	AL...-4X
			5.0	4XER5.0TR...	54479	.108	.06	.10		
			6.0	4XER6.0TR...	54480	.138	.03	.09		
 Internal	3/8"	.63	2.0	3XIR2.0TR...	54481	.049	.06	.04	YI3	AVR...-3X
			3.0	3XIR3.0TR...	54482	.069	.05	.06		
	1/2"	.87	4.0	4XIR4.0TR...	54483	.089	.06	.10	YI4	AVR...-4X
			5.0	4XIR5.0TR...	54484	.108	.06	.10		
			6.0	4XIR6.0TR...	54485	.138	.03	.09		

American ACME

External / Internal

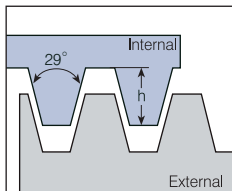

Defined by: ANSI B1.5:1988
Tolerance class: 3G

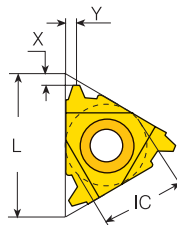

External

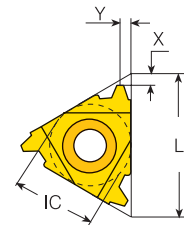

Internal

	Insert Size		Pitch	Ordering Code	EDP No.	Dimensions inch			Anvil	
	IC	L inch	tpi	RH	VKX	h min	X	Y	RH	Toolholder
 External	3/8"	.63	12	3XER12ACME...	54486	.047	.05	.05	YE3	AL...-3X
			10	3XER10ACME...	54487	.060	.05	.05		
			8	3XER8ACME...	54488	.072	.06	.05		
	1/2"	.87	6	4XER6ACME...	54489	.093	.05	.10	YE4	AL...-4X
			4	4XER4ACME...	54491	.135	.03	.09		
 Internal	3/8"	.63	12	3XIR12ACME...	54492	.047	.05	.05	YI3	AVR...-3X
			10	3XIR10ACME...	54493	.060	.05	.05		
	1/2"	.87	8	3XIR8ACME...	54494	.072	.05	.05	YI4	AVR...-4X
			6	4XIR6ACME...	54495	.093	.05	.09		
			5	4XIR5ACME...	54496	.110	.05	.09		
			4	4XIR4ACME...	54497	.135	.03	.09		

Stub ACME

External / Internal

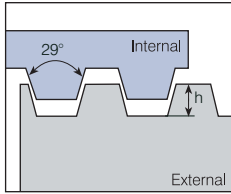

Defined by: ANSI B1.8:1988
Tolerance class: 2G

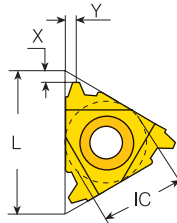

External

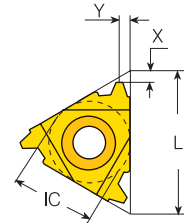

Internal

	Insert Size		Pitch	Ordering Code	EDP No.	Dimensions inch			Anvil	Toolholder	
	IC	L inch	tpi	RH	VKX	h min	X	Y	RH		
	External	3/8"	.63	12	3XER12STACME...	54538	.030	.05	.04	YE3	AL...-3X
				10	3XER10STACME...	54498	.040	.05	.05		
				8	3XER8STACME...	54499	.048	.04	.05		
				6	3XER6STACME...	54500	.060	.07	.06		
	Internal	3/8"	.63	12	3XIR12STACME...	54501	.030	.05	.04	Y13	AVR...-3X
				10	3XIR10STACME...	54502	.040	.05	.05		
				8	3XIR8STACME...	54503	.048	.04	.04		
				6	3XIR6STACME...	54504	.060	.07	.06		

UNJ

External / Internal

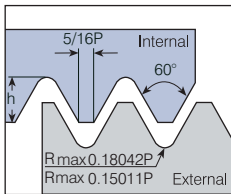

Defined by: MIL-S-8879C
Tolerance class: 3A/3B

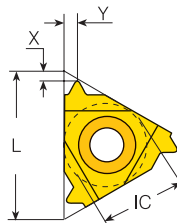

External

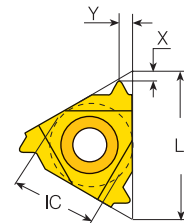

Internal

	Insert Size		Pitch	Ordering Code	EDP No.	Dimensions inch			Anvil	Toolholder	
	IC	L inch	tpi	RH	VKX	h min	X	Y	RH		
	External	3/8"	.63	24	3XER24UNJ...	54505	.024	.05	.03	YE3	AL...-3X
				20	3XER20UNJ...	54506	.029	.05	.03		
				18	3XER18UNJ...	54507	.032	.05	.04		
				16	3XER16UNJ...	54508	.036	.05	.04		
				12	3XER12UNJ...	54509	.048	.05	.06		
	Internal	1/4"	.43	18	2XIR18UNJ...	54510	.029	.03	.04	-	NVR...-2X
				14	2XIR14UNJ...	54511	.037	.03	.04		
		3/8"	.63	16	3XIR16UNJ...	54512	.033	.05	.04	Y13	AVR...-3X
				12	3XIR12UNJ...	54513	.044	.05	.06		

American Buttress

External / Internal

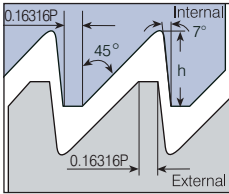

Defined by: ANSI B1.9.1973
Tolerance class: Class 2

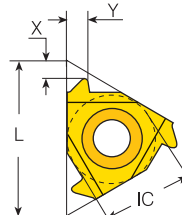

External

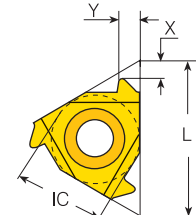

Internal



	Insert Size		Pitch	Ordering Code	EDP No.	Dimensions inch			Anvil	
	IC	L inch	tpi	RH	VKX	h min	X	Y	RH	Toolholder
	External	3/8"	.63	12	3XER12ABUT...	54514	.055	.06	.06	YE3 AL...-3X
	Internal	3/8"	.63	12	3XIR12ABUT...	54515	.055	.06	.06	YI3 AVR...-3X

API

External / Internal

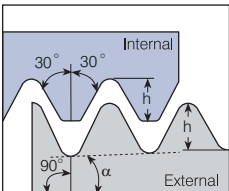

$$\alpha = \arctg (IPF/24)$$

Defined by: API SPEC. 7:1990
Tolerance class: Standard API

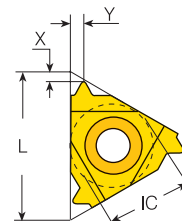

External

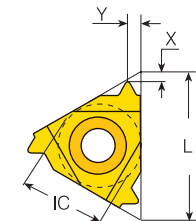

Internal

For additional information regarding the standard dimensions and tolerances, see page 15.

	Insert Size	Pitch	Thread	Taper	Ordering Code		Size	EDP No.	Dimensions inch			Anvil	
					IC	L inch			tpi	IPF	RH		VKX
	External	1/2"	.87	4	V-0.038R	2	4XER4API382...	NC23-NC50	54516	.122	.07	.10	YE4 AL...-4X
				4	V-0.038R	3	4XER4API383...	NC56-NC77	54517	.121	.07	.11	
				4	V-0.050	2	4XER4API502...	6 5/8" REG	54518	.148	.04	.11	
				4	V-0.050	3	4XER4API503...	5 1/2", 7 5/8", 8 5/8" REG	54519	.147	.04	.11	
	Internal	1/2"	.87	4	V-0.038R	2	4XIR4API382...	NC23-NC50	54521	.122	.06	.10	YI4 AVR...-4X
				4	V-0.038R	3	4XIR4API383...	NC56-NC77	54522	.121	.06	.11	
				4	V-0.050	2	4XIR4API502...	6 5/8" REG	54523	.148	.04	.11	
				4	V-0.050	3	4XIR4API503...	5 1/2", 7 5/8", 8 5/8" REG	54524	.147	.04	.11	
				5	V-0.040	3	4XIR5API403...	2 3/8" - 4 1/2" REG	54525	.118	.05	.10	

API Buttress Casing

External / Internal

Defined by: **STD.5B.1979**
Tolerance class: **Standard API**

$\alpha = \arctg (IPF/24)$

External **Internal**

For additional information regarding the standard dimensions and tolerances, see page 15.



	Insert Size		Pitch	Taper	Ordering Code	EDP No.	Dimensions inch			Anvil		
	IC	L inch	tpi	IPF	RH	VKX	h nominal	X	Y	RH	Toolholder	
	External	1/2"	.87	5	0.75	4XER5BUT75...	54526	.062	.08	.10	YE4	AL...-4X
				5	1	4XER5BUT1...	54527	.062	.08	.09		
	Internal	1/2"	.87	5	0.75	4XIR5BUT75...	54528	.062	.08	.11	Y14	AVR...-4X
				5	1	4XIR5BUT1...	54529	.062	.08	.08		

API Round Casing & Tubing

External / Internal

Defined by: **API STD. 5B:1979**
Tolerance class: **Standard API RD**

External **Internal**

For additional information regarding the standard dimensions and tolerances, see page 15.

	Insert Size		Pitch	Ordering Code	EDP No.	Dimensions inch			Anvil		
	IC	L inch	tpi	RH	VKX	h nominal	X	Y	RH	Toolholder	
	External	3/8"	.63	10	3XER10APIRD...	54530	.056	.05	.05	YE3	AL...-3X
				8	3XER8APIRD...	54531	.071	.05	.06		
		1/2"	.87	10	4XER10APIRD...	54532	.056	.07	.09	YE4	AL...-4X
				8	4XER8APIRD...	54533	.071	.07	.09		
	Internal	3/8"	.63	10	3XIR10APIRD...	54534	.056	.05	.05	Y13	AVR...-3X
				8	3XIR8APIRD...	54535	.071	.05	.06		
		1/2"	.87	10	4XIR10APIRD...	54536	.056	.06	.09	Y14	AVR...-4X
				8	4XIR8APIRD...	54537	.071	.06	.09		

External Toolholders

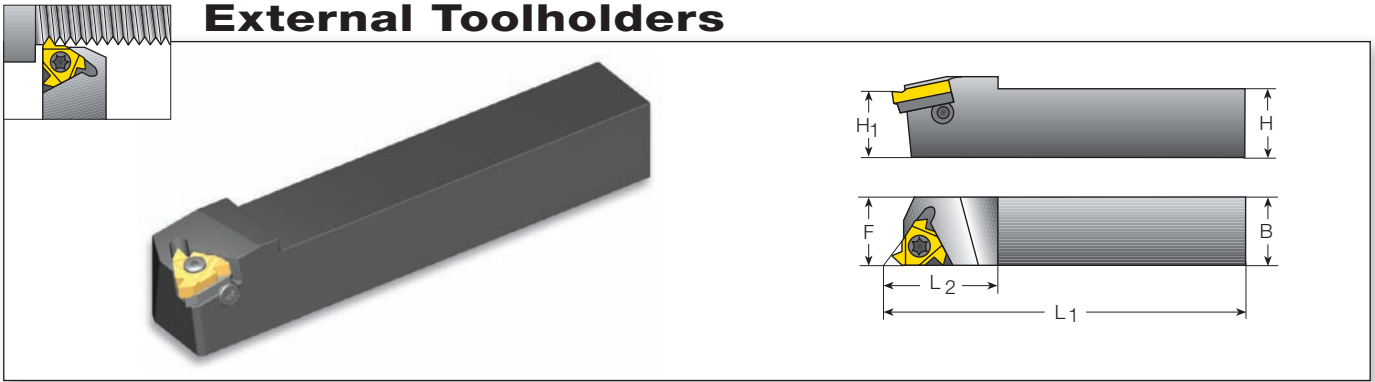

Insert Size	Ordering Code	EDP No.	Dimensions inch				Spare Parts (Ordering Code & EDP No.)				
IC	RH	H=H1=B	F	L1	L2	Insert Screw	Anvil Screw	Torx Key	Anvil RH	Anvil LH	
3/8"	AL050-3X	66349	.50	.63	3.27	.87	SA3TS (70030)	SY3T (70044)	K3T (70021)	YE3 (70052)	YI3 (70134)
	AL0625-3X	66353	.63	.63	5.00	1.02					
	AL075-3X	66350	.75	.75	5.00	1.02					
	AL100-3X	66351	1.00	1.00	6.00	1.20					
	AL125-3X	66352	1.25	1.25	7.00	1.18					
1/2"	AL100-4X	66375	1.00	1.00	5.93	1.18	SA4TS (70031)	SY4T (70045)	K4T (70022)	YE4 (70070)	YI4 (70155)
	AL125-4X	66376	1.25	1.25	6.93	1.38					

Internal Toolholders

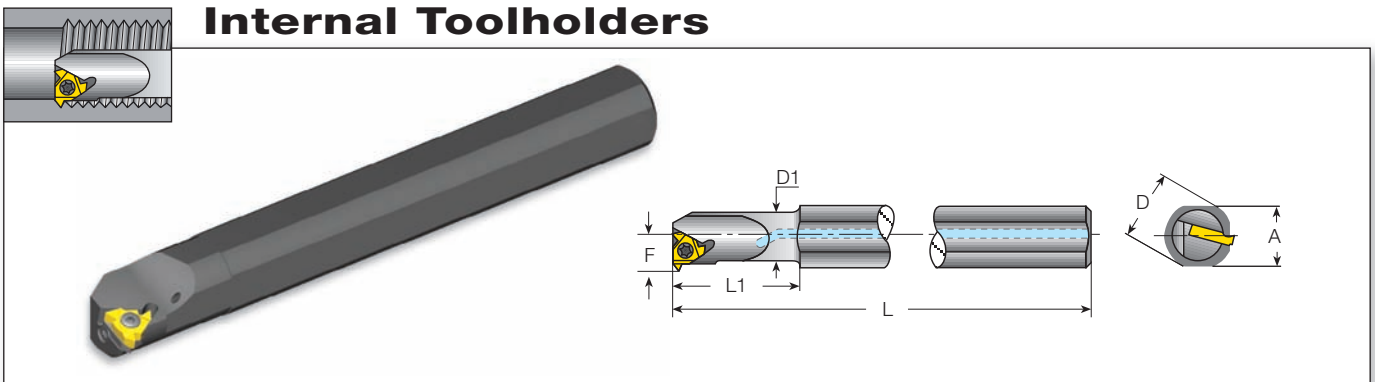

Insert Size	Ordering Code	EDP No.	Dimensions inch							Min. Bore dia.	Spare Parts (Ordering Code & EDP No.)				
IC	RH	A	L	L1	D	D1	F	inch		Insert Screw	Anvil Screw	Torx Key	Anvil RH	Anvil LH	
1/4"	NVRC0375-2X	66377	.67	7.0	.98	.75	.38	.25	.47	SN2TS (70047)	-	K2T (70020)	-	-	
	NVRC050-2X	66378	.67	7.0	1.30	.75	.50	.31	.59						
3/8"	NVRC050-3X	66354	.67	7.0	1.25	.75	.50	.40	.67	SN3TS (70034)	-	K3T (70021)	-	-	
	NVRC0625-3X	66359	.67	7.0	1.50	.75	.62	.46	.80						
	AVRC075-3X	66355	.67	7.0	1.50	.75	.75	.51	.90						
	AVRC100-3X	66356	1.12	10.0	2.50	1.25	1.00	.65	1.20	SA3TS (70030)	SY3T (70044)	K3T (70021)	YI3 (70134)	YE3 (70052)	
	AVRC125-3X	66357	1.12	10.0	2.50	1.25	1.25	.77	1.45						
AVRC150-3X	66358	1.34	12.0	2.50	1.50	1.50	.90	1.65							
1/2"	NVRC075-4X	66379	.67	7.0	1.93	.75	.74	.53	1.00	SN4TS (70048)	-	K4T (70022)	-	-	
	AVRC100-4X	66380	1.12	10.0	2.40	1.25	1.00	.65	1.24	SA4TS (70031)	SY4T (70045)	K4T (70022)	YI4 (70155)	YE4 (70070)	
	AVRC125-4X	66381	1.12	10.0	2.40	1.25	1.24	.76	1.48						

Calculating the Helix Angle β

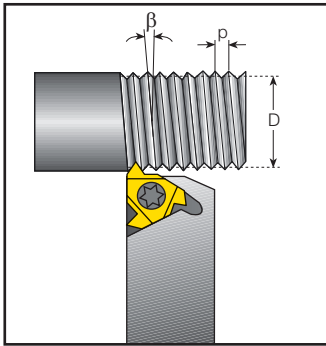

The helix angle is calculated by the following formula:

$$\beta = \arctan \frac{P \times N}{\pi \times D}$$

β - Helix angle [°]
 P - Pitch [inch]
 N - No. of starts
 D - Pitch diameter [inch]
 Lead = P x N

The helix angle can also be found from the diagram below.

Helix Angle Diagram

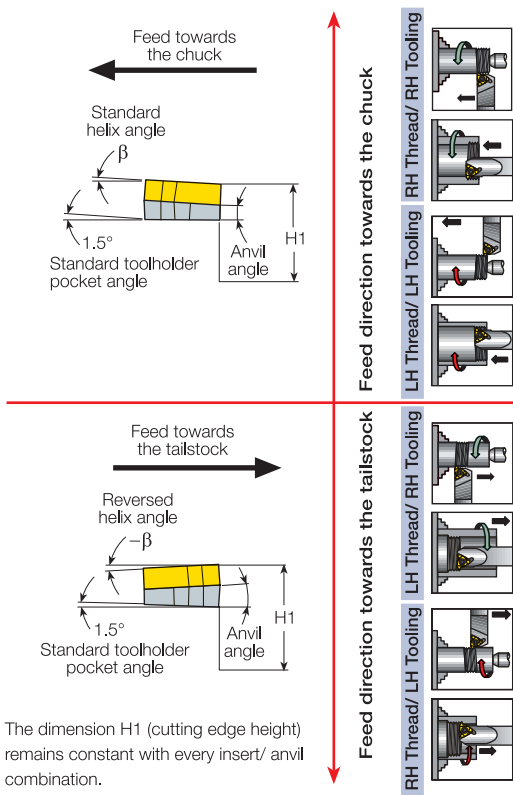

The dimension H1 (cutting edge height) remains constant with every insert/ anvil combination.

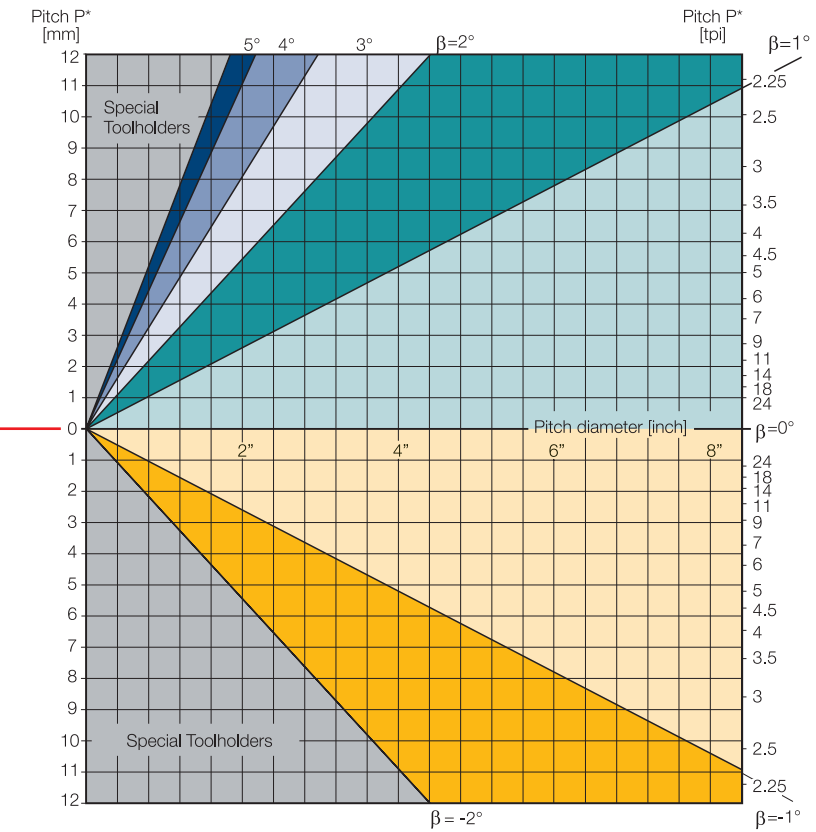

*For Multi-start threads, use the lead value instead of the pitch

Anvils

Resultant Helix Angle		4.5°	3.5°	2.5°	1.5°	0.5°	0°	-0.5°	-1.5°	
Insert Size	Holder	Ordering Code & EDP No.								
IC	L Inch									
3/8"	.63	ER / IL	YE3-3P	YE3-2P	YE3-1P	YE3	YE3-1N	YE3-1.5N	YE3-2N	YE3-3N
		EL / IR	(70063)	(70061)	(70059)	(70052)	(70058)	(70057)	(70060)	(70062)
3/8"	.63	ER / IL	YI3-3P	YI3-2P	YI3-1P	YI3	YI3-1N	YI3-1.5N	YI3-2N	YI3-3N
		EL / IR	(70146)	(70144)	(70141)	(70134)	(70140)	(70139)	(70143)	(70145)
1/2"	.87	ER / IL	YE4-3P	YE4-2P	YE4-1P	YE4	YE4-1N	YE4-1.5N	YE4-2N	YE4-3N
		EL / IR	(70081)	(70079)	(70077)	(70070)	(70076)	(70075)	(70078)	(70080)
1/2"	.87	ER / IL	YI4-3P	YI4-2P	YI4-1P	YI4	YI4-1N	YI4-1.5N	YI4-2N	YI4-3N
		EL / IR	(70166)	(70164)	(70162)	(70155)	(70161)	(70160)	(70163)	(70165)

API Standard Drawings

API

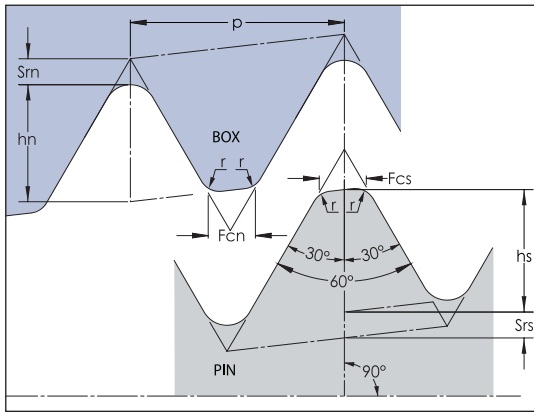

Thread form	IPF	Thread height truncated $h_s = h_n$	Root Truncation $S_{rn} = S_{rs}$	Width of flat $F_{cn} = F_{cs}$	Radius at thread corners (r)	Pitch (TPI)
V 0.038R	2	+ .001 - .003 .1218	+ .001 - .001 .038	+ .002 .065	+ .002 - .002 .015	4
V 0.038R	3	+ .001 - .003 .1214	+ .001 - .001 .038	+ .002 .065	+ .002 - .002 .015	4
V0.040	3	+ .001 - .003 .11784	+ .001 - .001 .02	+ .002 .04	+ .002 - .002 .015	5
V0.050	2	+ .001 - .003 .1478	+ .001 - .001 .025	+ .002 .05	+ .002 - .002 .015	4
V0.050	3	+ .001 - .003 .1473	+ .001 - .001 .025	+ .002 .05	+ .002 - .002 .015	4

API Round Casing & Tubing

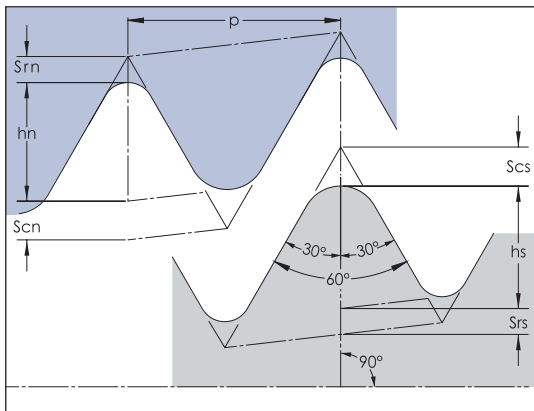

Thread Data	8 TPI	10 TPI
$h_s = h_n$	+ .002 - .004 .07125	+ .002 - .004 .0556
$S_{rn} = S_{rs}$.017	.014
$S_{cs} = S_{cn}$.020	.017

API Buttress Casing

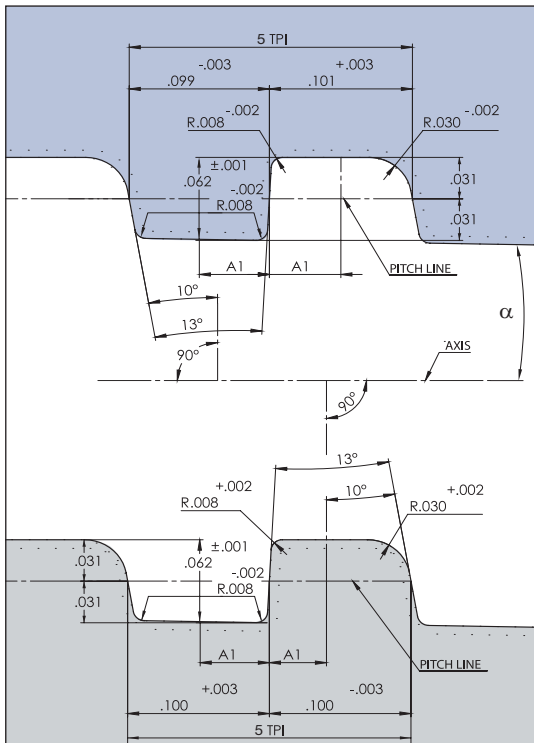

Taper	A1, inch	α	Profile Height
0.75	-	$1^\circ 47' 24''$	$\pm .001$
1	.05	$2^\circ 23' 17''$.062

Recommended Grades and Cutting Speeds Vc [ft/min]

Material Group	Vardex No.	Material	Hardness Brinell HB	Vc [ft/min]	
				Coated	VKX
P Steel	1	Unalloyed steel	Low carbon (C=0.1-0.25%)	125	377-623
	2		Medium carbon (C=0.25-0.55%)	150	328-574
	3		High carbon (C=0.55-0.85%)	170	295-541
	4	Low alloy steel (alloying elements ≤5%)	Non hardened	180	328-590
	5		Hardened	275	246-459
	6		Hardened	350	230-443
	7	High alloy steel (alloying elements >5%)	Annealed	200	262-394
	8		Hardened	325	164-328
	9	Cast steel	Low alloy (alloying elements ≤5%)	200	230-426
	10		High alloy (alloying elements >5%)	225	197-394
M Stainless Steel	11	Stainless steel Ferritic	Non hardened	200	230-426
	12		Hardened	330	197-377
	13	Stainless steel Austenitic	Austenitic	180	295-459
	14		Super Austenitic	200	131-360
	15	Stainless steel Cast ferritic	Non hardened	200	295-394
	16	Cast austenitic	Hardened	330	213-360
	17	Stainless steel Cast austenitic	Austenitic	200	279-360
	18	Cast austenitic	Hardened	330	197-328
K Cast Iron	28	Malleable Cast iron	Ferritic (short chips)	130	197-230
	29		Pearlitic (long chips)	230	197-476
	30	Grey Cast iron	Low tensile strength	180	230-426
	31		High tensile strength	260	197-377
	32	Nodular SG iron	Ferritic	160	410-525
	33		Pearlitic	260	295-394
N(K) Non-Ferrous Metals	34	Aluminium alloys Wrought	Non aging	60	328-1197
	35		Aged	100	262-722
	36	Aluminium alloys Cast	Cast	75	656-1312
	37		Cast & aged	90	656-590
	38	Aluminium alloys Cast Si 13-22%	Cast Si 13-22%	130	197-590
	39	Copper and copper alloys	Brass	90	262-738
40	Bronze and non leaded copper		100	262-837	
S(M) Heat Resistant Material	19	High temperature alloys	Annealed (Iron based)	200	148-197
	20		Aged (Iron based)	280	98-164
	21		Annealed (Nickel or Cobalt based)	250	66-98
	22		Aged (Nickel or Cobalt based)	350	49-82
	23	Titanium alloys	Pure 99.5 Ti	400Rm	459-558
24	α+β alloys		1050Rm	164-230	
H(K) Hardened Material	25	Extra hard steel	Hardened & tempered	45-50HRc	148-197
	26			51-55HRc	131-164

Calculation of N [RPM]

$$N = \frac{12 \times V_c}{\pi \times D}$$

$$V_c = \frac{N \times \pi \times D}{12}$$

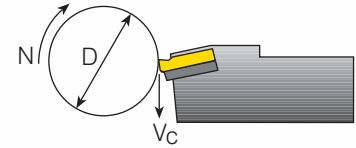

N - Revolution Per Minute [RPM]
Vc - Cutting Speed [ft/min]
D - Workpiece Diameter [inch]

Grade:

VKX



Superior general purpose grade, excellent in steels and stainless steels. TiN coated.

Number of Passes

Pitch	mm	0.50	0.75	1.00	1.25	1.50	1.75	2.00	2.50	3.00	3.50	4.00	4.50	5.00	5.50	6.00
	tpi	48	32	24	20	16	14	12	10	8	7	6	5.5	5	4.5	4
No. of passes		4-6	4-7	4-8	5-9	6-10	7-12	7-12	8-14	9-16	10-18	11-18	11-19	12-20	12-20	12-20