

# Turning



- > Threading
- > Grooving
- > Boring

# Thread Turning System - External

## Standard

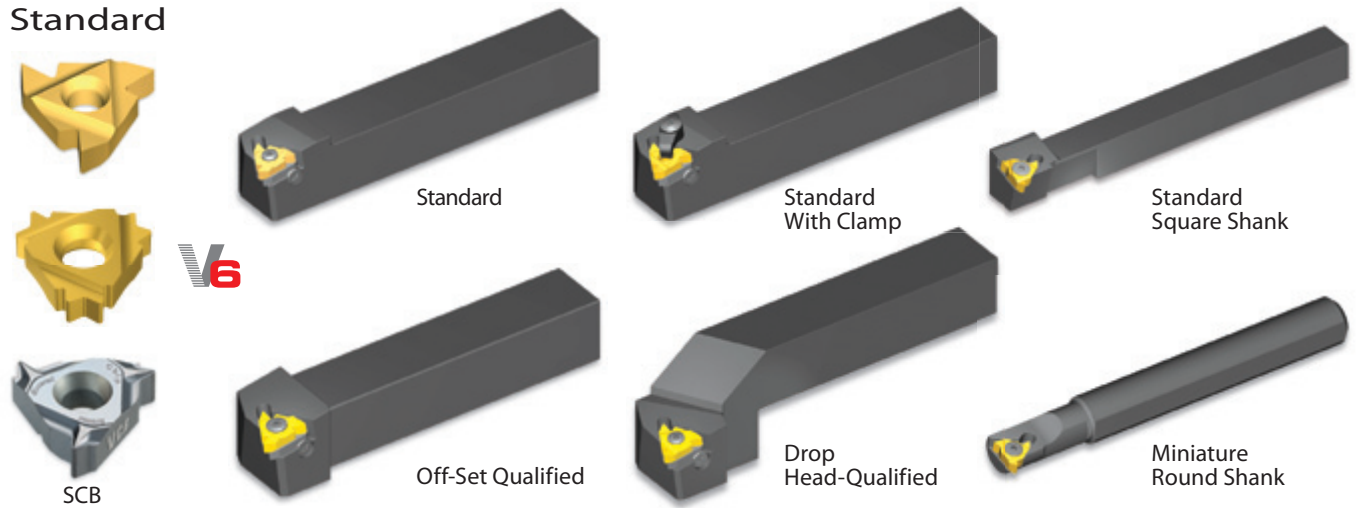

## U Style

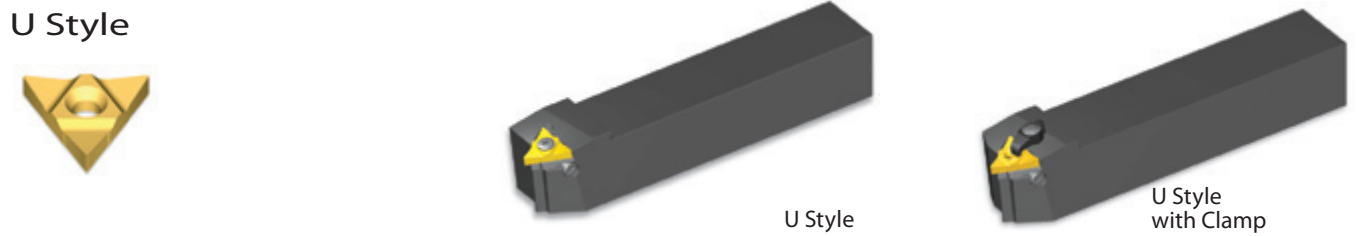

## V Style



## M+ Style



## Z+ Style



## T+ Style



# Thread Turning System - Internal

## Standard



V6

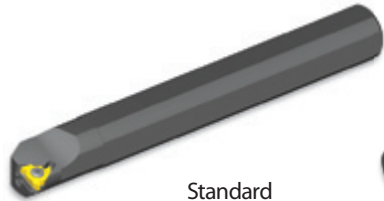

Standard

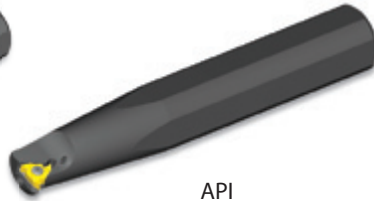

API

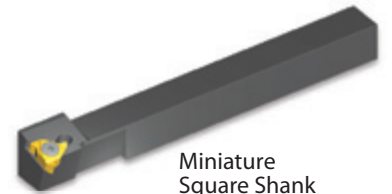

Miniature Square Shank



Standard With Clamp



Carbide Shank



Miniature Round Shank

## U Style

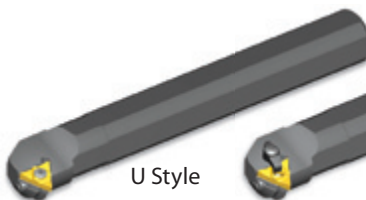

U Style



U Style with Clamp

## V Style

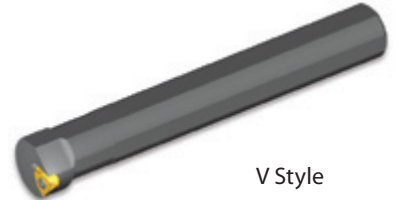

V Style

## M+ Style

Multiplus



M+ Style

## T+ Style

Multiplus



T+ Style

## Z+ Style

Multiplus



Z+ Style

## Mini-3

MINI PRO

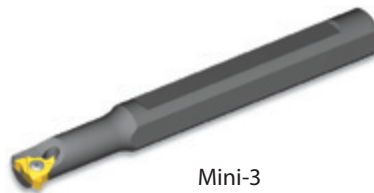

Mini-3



Mini-3 Adjustable

## Mini-L

MINI PRO

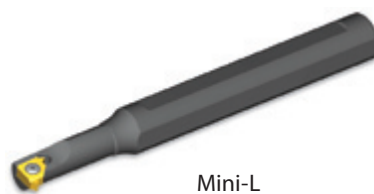

Mini-L



Mini-L Adjustable

## Micro

MINI PRO



Micro Double-Ended

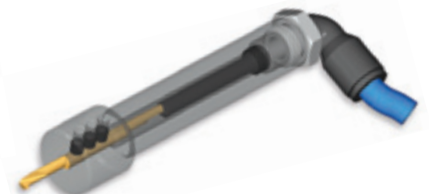

# Tooling recommendation for a given Internal thread specification

TT Gen Software  
and updated versions  
can be downloaded from  
[www.vargususa.com](http://www.vargususa.com)



## American UN

Pitch tpi	Thread	Insert Size	Ordering Code		
			Insert	Holder	Anvil
56	10 - 1/4	Micro 4.0	Special	SMC..-4.0	-
48	10 - 5/16	Micro 4.0	Special	SMC..-4.0	-
40	10 - 3/8	Micro 4.0	4.0SIR40UN	SMC..-4.0	-
36	12 - 3/8	Micro 4.0	4.0SIR36UN	SMC..-4.0	-
32	12 - 1/4	Micro 4.0	4.0SIR32UN	SMC..-4.0	-
	5/16 - 3/8	Micro 6.0	6.0SIR32UN	SMC..-6.0	-
	7/16 - 1/2	IC 6.0	6.0IR32UN	NVR...-6.0	-
	9/16 - 11/16	IC 1/4"	2IR32UN	NVR0375-2	-
	3/4 - 15/16	IC 3/8"	3IR32UN	NVR050-3	-
	7/8 - 15/16	IC 3/8"	3IR32UN	NVR0625-3	-
	1	IC 3/8"	3IR32UN	AVR075-3	Y13 - 1N
28	12 - 1/4	Micro 4.0	4.0SIR28UN	SMC..-4.0	-
	5/16 - 3/8	Micro 6.0	6.0SIR28UN	SMC..-6.0	-
	7/16 - 1/2	IC 6.0	6.0IR28UN	NVR...-6.0	-
	5/8 - 11/16	IC 1/4"	2IR28UN	NVR0375-2	-
	3/4 - 13/16	IC 3/8"	3IR28UN	NVR050-3	-
	7/8 - 15/16	IC 3/8"	3IR28UN	NVR0625-3	-
	1 - 1 1/8	IC 3/8"	3IR28UN	AVR075-3	Y13 - 1N
1 3/16	IC 3/8"	3IR28UN	AVR100-3	Y13 - 1N	
27	1/4	Micro 4.0	4.0SIR27UN	SMC..-4.0	-
	5/16 - 3/8	Micro 6.0	6.0SIR27UN	SMC..-6.0	-
	7/16 - 1/2	IC 6.0	Special	NVR...-6.0	-
	9/16 - 5/8	IC 1/4"	2IR27UN	NVR0375-2	-
	3/4	IC 3/8"	3IR27UN	NVR050-3	-
	7/8	IC 3/8"	3IR27UN	NVR0625-3	-
1	IC 3/8"	3IR27UN	AVR075-3	Y13 - 1N	
24	12 - 1/4	Micro 4.0	4.0SIR24UN	SMC..-4.0	-
	5/16 - 3/8	Micro 6.0	6.0SIR24UN	SMC..-6.0	-
	7/16	IC 5.0 L	5LIR24UN	NVR0375-5L	-
	1/2	IC 6.0	6.0IR24UN	NVR...-6.0	-
	9/16 - 11/16	IC 1/4"	2IR24UN	NVR0375-2	-
	3/4	IC 3/8"	3IR24UN	NVR050-3	-
	7/8	IC 3/8"	3IR24UN	NVR0625-3	-
	1 - 1 1/8	IC 3/8"	3IR24UN	AVR075-3	Y13 - 1N
1 1/4 - 1 1/2	IC 3/8"	3IR24UN	AVR100-3	Y13 - 1N	
1 5/8 - 24	IC 3/8"	3IR24UN	AVR125-3	Y13 - 1N	
20	5/16 - 3/8	Micro 6.0	6.0SIR20UN	SMC..-6.0	-
	7/16	IC 5.0 L	5LIR20UN	NVR0375-5L	-
	1/2 - 9/16	IC 6.0	6.0IR20UN	NVR...-6.0	-
	5/8 - 11/16	IC 1/4"	2IR20UN	NVR0375-2	-
	3/4 - 13/16	IC 3/8"	3IR20UN	NVR050-3	-
	7/8 - 15/16	IC 3/8"	3IR20UN	NVR0625-3	-
	1 - 1 3/16	IC 3/8"	3IR20UN	AVR075-3	Y13 - 1N
	1 1/4 - 1 1/2	IC 3/8"	3IR20UN	AVR100-3	Y13 - 1N
	1 9/16 - 1 13/16	IC 3/8"	3IR20UN	AVR125-3	Y13 - 1N
1 7/8 - 2 1/8	IC 3/8"	3IR20UN	AVR150-3	Y13 - 1N	

# Tooling recommendation for a given Internal thread specification

TT Gen Software  
and updated versions  
can be downloaded from  
[www.vargususa.com](http://www.vargususa.com)



## American UN (con't)

Pitch tpi	Thread	Insert Size	Ordering Code		
			Insert	Holder	Anvil
18	5/16 - 3/8	Micro 6.0	6.0SIR18UN	SMC...-6.0	-
	7/16	IC 5.0 L	5LIR18UN	NVR0375-5L	-
	1/2 - 9/16	IC 6.0	6.0IR18UN	NVR...-6.0	-
	5/8	IC 1/4"	2IR18UN	NVR0375-2	-
	3/4	IC 3/8"	3IR18UN	NVR050-3	-
	7/8 - 1	IC 3/8"	3IR18UN	NVR0625-3	-
	1 1/16 - 1 3/16	IC 3/8"	3IR18UN	AVR075-3	YI3 - 1N
	1 1/4 - 1 1/2	IC 3/8"	3IR18UN	AVR100-3	YI3 - 1N
	1 9/16 - 1 3/4	IC 3/8"	3IR18UN	AVR125-3	YI3 - 1N
	1 7/8 - 2	IC 3/8"	3IR18UN	AVR150-3	YI3 - 1N
16	3/8	Micro 6.0	6.0SIR16UN	SMC...-6.0	-
	7/16	IC 5.0 L	5LIR16UN	NVR0375-5L	-
	1/2 - 9/16	IC 6.0	6.0IR16UN	NVR...-6.0	-
	5/8 - 11/16	IC 1/4"	2IR16UN	NVR0375-2	-
	3/4 - 13/16	IC 3/8"	3IR16UN	NVR050-3	-
	7/8 - 1	IC 3/8"	3IR16UN	NVR0625-3	-
	1 1/16 - 1 1/8	IC 3/8"	3IR16UN	AVR075-3	YI3
	1 3/16	IC 3/8"	3IR16UN	AVR075-3	YI3 - 1N
	1 1/4 - 1 1/2	IC 3/8"	3IR16UN	AVR100-3	YI3 - 1N
	1 9/16 - 1 13/16	IC 3/8"	3IR16UN	AVR125-3	YI3 - 1N
14	7/16	IC 5.0 L	5LIR14UN	NVR0375-5L	-
	1/2 - 9/16	IC 6.0	6.0IR14UN	NVR...-6.0	-
	5/8	IC 1/4"	2IR14UN	NVR0375-2	-
	3/4	IC 3/8"	3IR14UN	NVR050-3	-
	7/8 - 1	IC 3/8"	3IR14UN	NVR0625-3	-
	1 1/8	IC 3/8"	3IR14UN	AVR075-3	YI3
	1 1/4	IC 3/8"	3IR14UN	AVR100-3	YI3
	1 3/8 - 1 1/2	IC 3/8"	3IR14UN	AVR100-3	YI3 - 1N
	1 5/8 - 1 3/4	IC 3/8"	3IR14UN	AVR125-3	YI3 - 1N
	1 7/8 - 2	IC 3/8"	3IR14UN	AVR150-3	YI3 - 1N
13	1/2 - 13	IC 6.0	6.0I13UN...158/001	BNVR050S-6.0	-
	9/16 - 11/16	IC 1/4"	2I12UN...158/002	NVRC040-2 157/001	-
	3/4 - 7/8	IC 3/8"	3IR12UN	NVR050-3	-
12	15/16 - 1	IC 3/8"	3IR12UN	NVR0625-3	-
	1 1/16 - 1 3/16	IC 3/8"	3IR12UN	AVR075-3	YI3
	1 1/4 - 1 1/2	IC 3/8"	3IR12UN	AVR100-3	YI3
	1 9/16 - 1 13/16	IC 3/8"	3IR12UN	AVR125-3	YI3
	1 7/8 - 2 1/8	IC 3/8"	3IR12UN	AVR150-3	YI3 - 1N
11	5/8 - 11	IC 1/4U"	2UIR11UN...158/003	NVRC044-2U 157/002	-
	7/8	IC 3/8"	3IR10UN	NVR050-3	-
	1 - 10	IC 3/8"	3IR10UN	NVR0625-3	-
10	1 1/8 - 10	IC 3/8"	3IR10UN	AVR075-3	YI3
	1 1/4 - 1 1/2	IC 3/8"	3IR10UN	AVR100-3	YI3
	1 5/8 - 1 3/4	IC 3/8"	3IR10UN	AVR125-3	YI3
	1 7/8 - 2	IC 3/8"	3IR10UN	AVR150-3	YI3

## Tooling recommendation for a given Internal thread specification

TT Gen Software  
and updated versions  
can be downloaded from  
[www.vargususa.com](http://www.vargususa.com)



### American UN (con't)

Pitch tpi	Thread	Insert Size	Ordering Code		
			Insert	Holder	Anvil
9	7/8 - 9	IC 3/8"	3IR9UN	NVR050-3	-
	1	IC 3/8"	3IR8UN	NVR0625-3	-
	1 1/16 - 1 3/16	IC 3/8"	3IR8UN	AVR075-3	YI3 - 1P
8	1 1/4	IC 3/8"	3IR8UN	AVR075-3	YI3
	1 5/16 - 1 1/2	IC 3/8"	3IR8UN	AVR100-3	YI3
	1 9/16 - 1 13/16	IC 3/8"	3IR8UN	AVR125-3	YI3
	1 7/8 - 2 1/8	IC 3/8"	3IR8UN	AVR150-3	YI3
	1 1/8 - 1 1/4	IC 1/2"	4IR7UN	NVR075-4	-
7	1 3/8 - 1 7/16	IC 1/2"	4IR6UN	NVR075-4	-
	1 1/2 - 1 5/8	IC 1/2"	4IR6UN	AVR100-4	YI4 - 1P
	1 11/16	IC 1/2"	4IR6UN	AVR100-4	YI4
	1 3/4 - 2	IC 1/2"	4IR6UN	AVR125-4	YI4
	2 1/8 - 6	IC 1/2"	4IR6UN	AVR150-4	YI4
5	1 3/4 - 5	IC 1/2"	4IR5UN	AVR100-4	YI4 - 1P
4.5	2 - 4 1/2	IC 5/8"	5IR4.5UN	AVR125-5	YI5 - 1P

# Tooling recommendation for a given Internal thread specification

TT Gen Software  
and updated versions  
can be downloaded from  
[www.vargususa.com](http://www.vargususa.com)



## ISO Metric

Pitch mm	Thread	Insert Size	Ordering Code		
			Insert	Holder	Anvil
0.70	4	Micro 3.0	3.0SIR0.7ISO	SMC...-3	-
	6	Micro 4.0	4.0SIR0.75ISO	SMC...-4	-
0.75	8	Micro 6.0	6.0SIR0.75ISO	SMC...-6	-
	10	IC 5.0 L	5LIR0.75ISO	NVR0375-5L	-
0.80	5	Micro 3.0	3.0SIR0.8ISO	SMC...-3	-
	M6	Micro 4.0	4.0SIR1.0ISO	SMC...-4	-
	8	Micro 6.0	6.0SIR1.0ISO	SMC...-6	-
1.00	10	IC 5.0 L	5LIR1.0ISO	NVR0375-5L	-
	12-14	IC 6.0	6.0IR1.0ISO	NVR...-6.0	-
	15-17	IC 1/4"	2IR1.0ISO	NVR0375-2	-
	18	IC 1/4"	2IR1.0ISO	NVR050-2	-
	20-24	IC 3/8"	3IR1.0ISO	NVR050-3	-
1.25	M8	Micro 6.0	6.0SIR1.25ISO	SMC...-6.0	-
	10	IC 5.0 L	5LIR1.25ISO	NVR0375-5L	-
	12-14	IC 6.0	6.0IR1.25ISO	NVR...-6.0	-
1.50	M10	IC 5.0 L	5LIR1.5ISO	NVR0375-5L	-
	12-14	IC 6.0	6.0IR1.5ISO	NVR...-6.0	-
	15-18	IC 1/4"	2IR1.5ISO	NVR0375-2	-
	20-25	IC 3/8"	3IR1.5ISO	NVR050-3	-
	26-28	IC 3/8"	3IR1.5ISO	AVR075-3	YI3
	30-36	IC 3/8"	3IR1.5ISO	AVR075-3	YI3-1N
	38-45	IC 3/8"	3IR1.5ISO	AVR125-3	YI3-1N
48-68	IC 3/8"	3IR1.5ISO	AVR150-3	YI3-1N	
1.75	M12	IC 6.0	6.0IR1.75ISO	NVR...-6.0	-
	M14	IC 6.0	6.0IR2.0ISO	NVR1...-6.0	-
	M16-18	IC 1/4"	2IR2.0ISO	NVR0375-2	-
	20-22	IC 3/8"	3IR2.0ISO	NVR050-3	-
2.00	24	IC 3/8"	3IR2.0ISO	NVR0625-3	-
	27-30	IC 3/8"	3IR2.0ISO	AVR075-3	YI3
	33-36	IC 3/8"	3IR2.0ISO	AVR100-3	YI3
	39-45	IC 3/8"	3IR2.0ISO	AVR125-3	YI3-1N
	48-68	IC 3/8"	3IR2.0ISO	AVR150-3	YI3-1N
2.50	M18	IC 1/4"	2IR2.5ISO	NVR0375-2	-
	M20-M22	IC 3/8"	3IR2.5ISO	NVR050-3	-
	M24-M27	IC 3/8"	3IR3.0ISO	NVR0625-3	-
3.00	36-45	IC 3/8"	3IR3.0ISO	AVR100-3	YI3
	48-68	IC 3/8"	3IR3.0ISO	AVR150-3	YI3
3.50	M30-M33	IC 3/8"	3IR3.5ISO	NVR0625-3	-
	M36	IC 1/2"	4IR4.0ISO	NVR075-4	-
4.00	M39	IC 1/2"	4IR4.0ISO	AVR100-4	YI4
	56-68	IC 1/2"	4IR4.0ISO	AVR150-4	YI4
4.50	M42	IC 1/2"	4IR4.5ISO	AVR100-4	YI4-1P
	M45	IC 1/2"	4IR4.5ISO	AVR125-4	YI4
5.00	M48	IC 1/2"	4IR5.0ISO	AVR125-4	YI4-1P
	M52	IC 1/2"	4IR5.0ISO	AVR125-4	YI4
5.50	M56-60	IC 5/8"	5IR5.5ISO	AVR150-5	YI5
6.00	M64-68	IC 5/8"	5IR6.0ISO	AVR150-5	YI5

# Tooling recommendation for a given Internal thread specification

TT Gen Software  
and updated versions  
can be downloaded from  
[www.vargususa.com](http://www.vargususa.com)



## Whitworth

Pitch tpi	Thread	Insert Size	Ordering Code		
			Insert	Holder	Anvil
26	1/4	Micro 4.0	4.0SIR26W	SMC..-4.0	-
	5/16 - 1/2	Micro 6.0	6.0SIR26W	SMC..-6.0	-
	9/16 - 5/8	IC 1/4"	2IR26W	NVR0375-2	-
	11/16	IC 1/4"	2IR26W	NVR050-2	-
	3/4 - 13/16	IC 3/8"	3IR26W	NVR050-3	-
	7/8 - 15/16	IC 3/8"	3IR26W	NVR0625-3	-
	1 - 1 3/16	IC 3/8"	3IR26W	AVR075-3	YI3 - 1N
	1 1/4 - 1 7/16	IC 3/8"	3IR26W	AVR100-3	YI3 - 1N
	1 1/2 - 1 3/4	IC 3/8"	3IR26W	AVR125-3	YI3 - 1N
22	1 7/8 - 2	IC 3/8"	3IR26W	AVR150-3	YI3 - 1N
	5/16	Micro 6.0	6.0SIR22W	SMC..-6.0	-
20	3/8 - 9/16	Micro 6.0	6.0SIR20W	SMC..-6.0	-
	5/8 - 11/16	IC 1/4"	2IR20W	NVR0375-2	-
	3/4 - 13/16	IC 3/8"	3IR20W	NVR050-3	-
	7/8 - 1	IC 3/8"	3IR20W	NVR0625-3	-
	1 1/16 - 1 3/16	IC 3/8"	3IR20W	AVR075-3	YI3 - 1N
	1 1/4 - 1 7/16	IC 3/8"	3IR20W	AVR100-3	YI3 - 1N
	1 1/2 - 1 3/4	IC 3/8"	3IR20W	AVR125-3	YI3 - 1N
	1 7/8 - 3	IC 3/8"	3IR20W	AVR150-3	YI3 - 1N
	11/16	IC 1/4"	2IR16W	NVR0375-2	-
	3/4 - 11/16	IC 3/8"	3IR16W	NVR050-3	-
16	7/8 - 1	IC 3/8"	3IR16W	NVR0625-3	-
	1 1/16 - 1 1/8	IC 3/8"	3IR16W	AVR075-3	YI3
	1 3/16	IC 3/8"	3IR16W	AVR075-3	YI3 - 1N
	1 1/4 - 1 7/16	IC 3/8"	3IR16W	AVR100-3	YI3 - 1N
	1 1/2 - 1 3/4	IC 3/8"	3IR16W	AVR125-3	YI3 - 1N
	1 7/8 - 4 5/8	IC 3/8"	3IR16W	AVR150-3	YI3 - 1N
14	4 3/4 - 7	IC 3/8"	3IR16W	AVR150-3	YI3 - 1.5N
	7/16	IC 5.0 L	5LIR14W	NVR0375-5L	-
12	5/8 - 11/16	IC 1/4"	2IR14W	NVR0375-2	-
	13/16	IC 3/8"	3IR12W	NVR050-3	-
	15/16 - 1	IC 3/8"	3IR12W	NVR0625-3	-
	1 1/16 - 1 3/16	IC 3/8"	3IR12W	AVR075-3	YI3
	1 1/4 - 1 1/2	IC 3/8"	3IR12W	AVR100-3	YI3
	1.6 - 1 3/4	IC 3/8"	3IR12W	AVR125-3	YI3 - 1N
	1 7/8 - 6	IC 3/8"	3IR12W	AVR150-3	YI3 - 1N
	6 1/4 - 7	IC 3/8"	3IR12W	AVR150-3	YI3 - 1.5N
11	7/8	IC 3/8"	3IR11W	NVR050-3	-
10	1	IC 3/8"	3IR10W	NVR0625-3	-



## Tooling recommendation for a given Internal thread specification

TT Gen Software  
and updated versions  
can be downloaded from  
[www.vargususa.com](http://www.vargususa.com)



### Whitworth (con't)

Pitch tpi	Thread	Insert Size	Insert	Holder	Anvil
9	7/8	IC 3/8"	3IR9W	NVR050-3	-
	1 1/8 - 1 1/4	IC 3/8"	3IR9W	AVR075-3	Y13
8	1	IC 3/8"	3IR8W	NVR0625-3	-
	1 3/16	IC 3/8"	3IR8W	AVR075-3	Y13 - 1P
	1 5/16 - 1 1/2	IC 3/8"	3IR8W	AVR100-3	Y13
	1.6 - 1 7/8	IC 3/8"	3IR8W	AVR125-3	Y13
	1.9 - 2 1/4	IC 3/8"	3IR8W	AVR150-3	Y13
7	2.4 - 7	IC 3/8"	3IR8W	AVR150-3	Y13 - 1N
	1 1/4	IC 1/2"	4IR7W	NVR075-4	-
	1 3/4 - 2	IC 1/2"	4IR7W	AVR125-4	Y14
6	1 5/16 - 1 7/16	IC 1/2"	4IR6W	NVR075-4	-
	1 1/2 - 1 5/8	IC 1/2"	4IR6W	AVR100-4	Y14 - 1P
	1 7/8 - 1.9	IC 1/2"	4IR6W	AVR125-4	Y14
	2.1 - 3.1	IC 1/2"	4IR6W	AVR150-4	Y14
	3 1/4 - 7	IC 1/2"	4IR6W	AVR150-4	Y14 - 1N
5	1 3/4	IC 1/2"	4IR5W	AVR100-4	Y14 - 1P
	3 - 3 1/4	IC 1/2"	4IR5W	AVR150-4	Y14
4.5	2	IC 5/8"	5IR4.5W	AVR125-5	Y15 - 1P
	3 1/2 - 4	IC 5/8"	5IR4.5W	AVR250-5	Y15
4	2 1/4	IC 5/8"	5IR4W	AVR150-5	Y15 - 1P
	2 1/2	IC 5/8"	5IR4W	AVR150-5	Y15
	4 1/4 - 4 3/4	IC 5/8"	5IR4W	AVR250-5	Y15
	4 7/8 - 7	IC 5/8"	5IR4W	AVR250-5	Y15 - 1N
3.5	2 3/4	IC 5/8" U	5UEI3.5W	AVR150-5U	Y15U - 1P
	3	IC 5/8" U	5UEI3.5W	AVR200-5U	Y15U
3.25	3 1/4	IC 5/8" U	5UEI3.25W	AVR200-5U	Y15U
	3 1/2	IC 5/8" U	5UEI3.25W	AVR250-5U	Y15U
3	3 3/4 - 4	IC 5/8" U	5UEI3W	AVR250-5U	Y15U
2.75	5	IC 5/8" U	5UEI2.75W	AVR250-5U	Y15U
2.5	6	IC 5/8" V	5VIR2.5W	NVR250-5V	-

# Tooling recommendation for a given Internal thread specification

TT Gen Software  
and updated versions  
can be downloaded from  
[www.vargususa.com](http://www.vargususa.com)



## NPT

Pitch tpi	Thread	Insert Size	Ordering Code		
			Insert	Holder	Anvil
27	1/16	Micro 6.0	6.0SIR27NPT	SMC...-6.0	-
	18	1/4	6.0SIR18NPT	SMC...-6.0	-
		3/8	6.0SIR18NPT	SMC...-6.0	-
14	1/2	IC 3/8"	3IR14NPT	NVR050-3	-
	3/4	IC 3/8"	3IR14NPT	NVR050-3	-
11.5	1	IC 3/8"	3IR11.5NPT	AVR075-3	Y13
	1 1/4	IC 3/8"	3IR11.5NPT	AVR125-3	Y13
	1 1/2	IC 3/8"	3IR11.5NPT	AVR125-3	Y13 - 1N
	2	IC 3/8"	3IR11.5NPT	AVR150-3	Y13 - 1N
	2 1/2	IC 3/8"	3IR8NPT	AVR150-3	Y13 - 1N
	3	IC 3/8"	3IR8NPT	AVR150-3	Y13 - 1N
	3 1/2	IC 3/8"	3IR8NPT	AVR150-3	Y13 - 1N
8	4	IC 3/8"	3IR8NPT	AVR150-3	Y13 - 1N
	5	IC 3/8"	3IR8NPT	AVR150-3	Y13 - 1N
	6	IC 3/8"	3IR8NPT	AVR150-3	Y13 - 1N
	8	IC 3/8"	3IR8NPT	AVR150-3	Y13 - 1N
	10	IC 3/8"	3IR8NPT	AVR150-3	Y13 - 1N
	12	IC 3/8"	3IR8NPT	AVR150-3	Y13 - 1N

## NPTF

Pitch tpi	Thread	Insert Size	Ordering Code		
			Insert	Holder	Anvil
27	1/8	IC 5.0 L	5LIR27NPTF	NVR...-5L	-
18	1/4	IC 6.0	6.0IR18NPTF	NVR1...-6.0	-
	3/8	IC 1/4"	2IR18NPTF	NVR0375-2	-
14	1/2	IC 3/8"	3IR14NPTF	NVR050-3	-
	3/4	IC 3/8"	3IR14NPTF	NVR0625-3	-
11.5	1	IC 3/8"	3IR11.5NPTF	AVR075-3	Y13
	1 1/4	IC 3/8"	3IR11.5NPTF	AVR125-3	Y13
	1 1/2	IC 3/8"	3IR11.5NPTF	AVR125-3	Y13 - 1N
	2	IC 3/8"	3IR11.5NPTF	AVR150-3	Y13 - 1N
8	2 1/2	IC 3/8"	3IR8NPTF	AVR150-3	Y13 - 1N
	3	IC 3/8"	3IR8NPTF	AVR150-3	Y13 - 1N

## PG

Pitch tpi	Thread	Insert Size	Ordering Code		
			Insert	Holder	Anvil
20	Pg 7	IC 6.0	6.0IR20PG	NVR...6.0	-
	Pg 9	IC 1/4"	2IR18PG	NVR0375-2	-
18	Pg 11 & Pg 13.5	IC 3/8"	3IR18PG	NVR050-3	-
	Pg 16	IC 3/8"	3IR18PG	NVR0625-3	-
16	Pg 21	IC 3/8"	3IR16PG	AVR075-3	Y13
	Pg 29	IC 3/8"	3IR16PG	AVR100-3	Y13 - 1N
	Pg 36 & Pg 42 & Pg 48	IC 3/8"	3IR16PG	AVR150-3	Y13 - 1N

## Tooling recommendation for a given Internal thread specification

TT Gen Software  
and updated versions  
can be downloaded from  
[www.vargususa.com](http://www.vargususa.com)



### BSP (55°)

Pitch tpi	Thread	Insert Size	Ordering Code		
			Insert	Holder	Anvil
28	G1/16	Micro 6.0	6.0SIR28W	SMC...-6.0	-
	G1/8	IC 5.0 L	5LIR28W	NVR0375-5L	-
19	G1/4	IC 6.0	6.0IR19W	NVR ...-6.0	-
	G3/8	IC 1/4"	2IR19W	NVR0375-2	-
14	G1/2 & G5/8	IC 3/8"	3IR14W	NVR050-3	-
	G3/4 & G7/8	IC 3/8"	3IR14W	AVR075-3	Y13
11	G1 & G1 1/8 & 1 1/4	IC 3/8"	3IR11W	AVR100-3	Y13
	G1 1/2	IC 3/8"	3IR11W	AVR150-3	Y13 - 1N
	G1 3/4	IC 3/8"	3IR11W	AVR150-3	Y13 - 1N
	G2	IC 3/8"	3IR11W	AVR150-3	Y13 - 1N
	G2 1/4	IC 3/8"	3IR11W	AVR150-3	Y13 - 1N
	G2 1/2	IC 3/8"	3IR11W	AVR150-3	Y13 - 1N
	G2 3/4	IC 3/8"	3IR11W	AVR150-3	Y13 - 1N
	G3	IC 3/8"	3IR11W	AVR150-3	Y13 - 1N
	G3 1/2	IC 3/8"	3IR11W	AVR150-3	Y13 - 1N
	G4	IC 3/8"	3IR11W	AVR150-3	Y13 - 1N
	G4 1/2	IC 3/8"	3IR11W	AVR150-3	Y13 - 1N
	G5	IC 3/8"	3IR11W	AVR150-3	Y13 - 1N
	G5 1/2	IC 3/8"	3IR11W	AVR150-3	Y13 - 1N
	G6	IC 3/8"	3IR11W	AVR150-3	Y13 - 1N

### BSPT

Pitch tpi	Thread	Insert Size	Ordering Code		
			Insert	Holder	Anvil
28	1/8	IC 5.0 L	5LIR28BSPT	NVR...-5L	-
19	1/4	IC 6.0	6.0IR19BSPT	NVR...-6.0	-
	3/8	IC 1/4"	2IR19BSPT	NVR0375-2	-
14	1/2	IC 3/8"	3IR14BSPT	NVR050-3	-
	3/4	IC 3/8"	3IR14BSPT	AVR075-3	Y13
11	1	IC 3/8"	3IR11BSPT	AVR100-3	Y13
	1 1/4	IC 3/8"	3IR11BSPT	AVR125-3	Y13
	1 1/2	IC 3/8"	3IR11BSPT	AVR150-3	Y13 - 1N
	2	IC 3/8"	3IR11BSPT	AVR150-3	Y13 - 1N
	2 1/2	IC 3/8"	3IR11BSPT	AVR150-3	Y13 - 1N
	3	IC 3/8"	3IR11BSPT	AVR150-3	Y13 - 1N
	4	IC 3/8"	3IR11BSPT	AVR150-3	Y13 - 1N
	5	IC 3/8"	3IR11BSPT	AVR150-3	Y13 - 1N
6	IC 3/8"	3IR11BSPT	AVR150-3	Y13 - 1N	





# Thread Turning

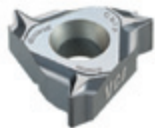

> Inserts

# THREAD TURNING INSERTS





■ VARDEX Ordering Code System.....	Page 19
■ Partial Profile 60°.....	Page 20
■ Partial Profile 55°.....	Page 23
■ American UN.....	Page 26
■ ISO Metric.....	Page 36
■ Whitworth for BSW, BSP.....	Page 45
■ BSPT.....	Page 53
■ NPT.....	Page 56
■ NPTF.....	Page 61
■ NPS.....	Page 64
■ Round (DIN 405).....	Page 65
■ Round (DIN 20400).....	Page 66
■ Trapez.....	Page 67
■ American ACME.....	Page 70
■ Stub ACME.....	Page 73
■ UNJ.....	Page 76
■ MJ.....	Page 81
■ American Buttress.....	Page 83
■ British Buttress.....	Page 85
■ Metric Buttress (Sägengewinde).....	Page 86
■ API.....	Page 87
■ API Buttress Casing.....	Page 88
■ API Round Casing & Tubing.....	Page 89
■ VAM.....	Page 91
■ EL-Extreme Line.....	Page 92
■ Hughes H-90.....	Page 93
■ Pg.....	Page 94

# Vardex Ordering Code System

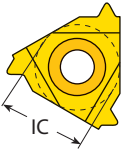
## Threading Inserts (Not Including Micro Systems)

<b>3</b>		<b>E</b>	<b>R</b>	<b>12</b>	<b>UN</b>				<b>VTX</b>	
<b>1</b>	<b>2</b>	<b>3</b>	<b>4</b>	<b>5</b>	<b>6</b>	<b>7</b>	<b>8</b>	<b>9</b>	<b>10</b>	<b>12</b>

1 - Insert Size
5L - IC5.0L mm 4.0K - IC4.0 mm 6.0 - IC6.0 mm 2 - IC1/4" 3 - IC 3/8" 4 - IC 1/2" 5 - IC5/8"

2 - Insert Style
U  V  L  J  SCB

3 - Type of Insert
E - External I - Internal EI - External +Internal

4 - RH/LH Insert
R - Right Hand Insert L - Left Hand Insert None - Right + Left Insert



5 - Pitch	
Full Profile - Pitch Range	
mm	tpi
0.35-12.0	72-2
Partial Profile - Pitch Range	
mm	tpi
A 0.5 - 1.5	48 - 16
AG 0.5 - 3.0	48 - 8
G 1.75 - 3.0	14 - 8
N 3.5 - 5.0	7 - 5
U 5.5 - 8.0	4½ - 3½
Q 5.5 - 6.0	4½ - 4
U 6.5 - 9.0	4 - 2¾
V 6.0 - 10.0	4 - 2½

6 - Standard	
60° - Partial Profile 60° 55° - Partial Profile 55° ISO - ISO Metric UN - American UN W - Whitworth for BSW, BSP BSPT - British Standard Pipe Thread NPT - NPT NPTF - NPTF NPS - NPS RD - Round DIN 405 RD20400 - Round DIN 20400 TR - Tarpez DIN 103 ACME - ACME	STACME - Stub ACME UNJ - UNJ MJ - ISO 5855 ABOUT - American Butterss BBUT - British Buttress SAGE - Metric Buttress DIN 513 API - API BUT - API Buttress Casing APIRD - API Round Casing & Tubing VAM - VAM EL - Extreme Line Casing H90 - H90 PG - Pg DIN 40430

7 - No. of Cutting Corners
6C - V6 Cutting Corners None - All Others

8 - API Form
382 2
383 3
403 15
502 75
503 125

9 - No. of Teeth
(for multitooth Style)
2, 3, 5, 6, 8

10 - Multi tooth Style
M+  T+  Z+  <b>Multiplus</b>

11 - Carbide Grade
VKX, VTX, VCB, VM7, VK2, VK2P, VKP, VHX, VBX

12 - Coarse Pitch Inserts
158/...

## Micro Threading Inserts - Double Ended

<b>3</b>	<b>S</b>	<b>I</b>	<b>R</b>	<b>32</b>	<b>UN</b>	<b>VMX</b>
<b>1</b>	<b>2</b>	<b>3</b>	<b>4</b>	<b>5</b>	<b>6</b>	<b>7</b>

1 - Insert Dia.
3.0 - 3.0 mm 4.0 - 4.0 mm 6.0 - 6.0 mm 8.0 - 8.0 mm 10.0 - 10.0 mm

2 - Insert Style
S - Micro Insert

3 - Type of Insert
I - Internal

4 - RH/LH Insert
R - Right Hand Insert L - Left Hand Insert

5 - Pitch	
Full Profile - Pitch Range	
mm	tpi
0.30-1.5	40-16
Partial Profile - Pitch Range	
mm	tpi
A 0.5 - 1.5	A 48 - 16
F 0.5 - 3.0	F 48 - 24

6 - Standard
60° - Partial Profile 60° 55° - Partial Profile 55° ISO - ISO Metric MJ - ISO 5855 NPT - NPT NPTF - NPTF UN - American UN W - Whitworth for BSW, BSP

7 - Carbide Grades
VMX

# Partial Profile 60°

## External

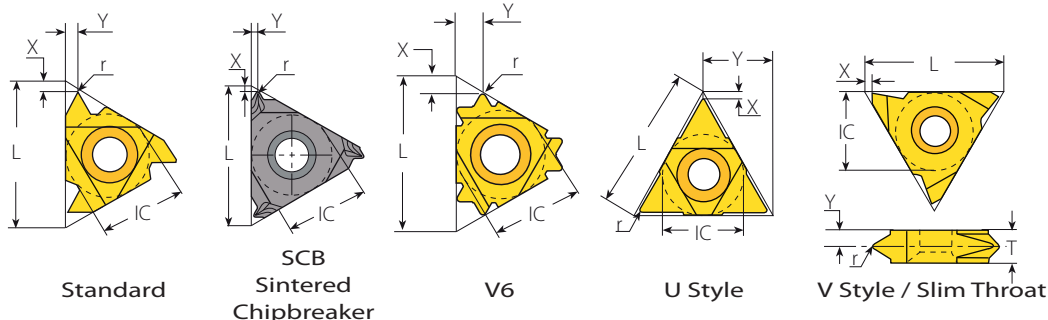
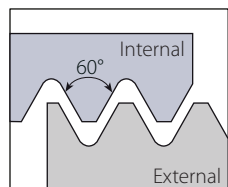

## Standard



Insert Size		Pitch		Ordering Code		Dimensions inch			Anvil		Toolholder
IC	L inch	mm	tpi	RH	LH	r	X	Y	RH	LH	
1/4"	0.43	0.5-1.5	48-16	2ERA60...	2ELA60...	0.002	0.03	0.04	-	-	NL..-2 (LH)
		0.5-1.5	48-16	3ERA60...	3ELA60...	0.002	0.03	0.04			
3/8"	0.63	1.75-3.0	14-8	3ERG60...	3ELG60...	0.011	0.05	0.07	YE3	YI3	AL..-3 (LH)
		0.5-3.0	48-8	3ERAG60...	3ELAG60...	0.003	0.05	0.07			
3/8" SCB	0.63	0.5-1.5	48-16	3JERA60...		0.002	0.02	0.03			
		1.75-3.0	14-8	3JERG60...		0.011	0.04	0.06	YE3	-	AL..-3
		0.5-3.0	48-8	3JERAG60...		0.003	0.04	0.06			
3/8" V6	0.63	0.5-2.0	48-13	3ERS60-6C...		0.002	0.07	0.12	YE3-6C	-	AL..-3
1/2"	0.87	3.5-5.0	7-5	4ERN60...	4ELN60...	0.021	0.07	0.10	YE4	YI4	AL..-4 (LH)
5/8"	1.06	5.5-6.0	4.5-4	5ERQ60...	5ELQ60...	0.025	0.08	0.12	YE5	YI5	AL..-5 (LH)

## U Style



Insert Size		Pitch		Ordering Code		Dimensions inch			Anvil		Toolholder
IC	L inch	mm	tpi	RH+LH		r	X	Y	RH	LH	
1/2"U	0.87	5.5-8.0	4.5-3.25	4UEIU60...		0.012	0.02	0.43	YE4U	YI4U	AL..-4U (LH)
5/8"U	1.06	6.5-9.0	4-2.75	5UEIU60...		0.015	0.04	0.54	YE5U	YI5U	AL..-5U (LH)

## Slim Throat



Insert Size		Pitch		Ordering Code		Dimensions inch				Toolholder
IC	L inch	mm	tpi	RH	LH	r	X	Y	T	
1/4"V	0.43	0.5-1.5	48-16	2VERA60...	2VELA60...	0.002	0.03	0.09	0.13	NL..-2V (LH)
		0.5-1.5	48-16	3VERA60...	3VELA60...	0.002	0.04	0.11	0.14	
3/8"V	0.63	1.75-3.0	14-8	3VERG60...	3VELG60...	0.011	0.04	0.07	0.14	NL..-3V (LH)
		0.5-3.0	48-8	3VERAG60...	3VELAG60...	0.003	0.04	0.07	0.14	
1/2"V	0.87	3.5-5.0	7-5	4VERN60...	4VELN60...	0.021	0.04	0.09	0.19	NL..-4V (LH)

## V Style



Insert Size		Pitch		Ordering Code		Dimensions inch				Toolholder
IC	L inch	mm	tpi	RH	LH	r	X	Y	T	
5/8"V	1.06	6.0-10.0	4-2.5	5VERV60...	5VELV60...	0.030	0.02	0.20	0.39	NL..-5V-10 (LH)



## Partial Profile 60° (con't)

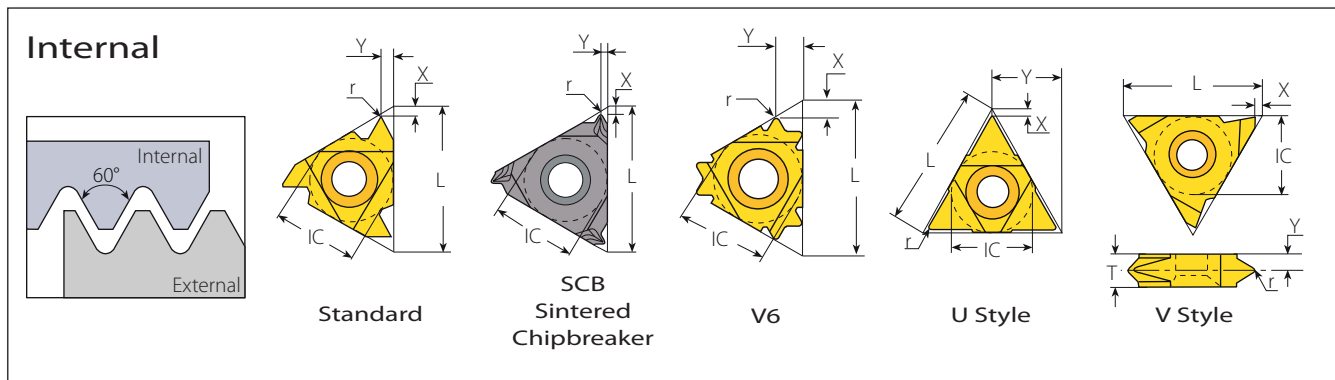

### Standard



Insert Size		Pitch		Ordering Code		Dimensions inch			Anvil		Toolholder
IC	L inch	mm	tpi	RH	LH	r	X	Y	RH	LH	
1/4"	0.43	0.5-1.5	48-16	2IRA60...	2ILA60...	0.002	0.03	0.04	-	-	NVR...-2 (LH)
1/4" SCB	0.43	0.5-1.5	48-16	2JIRA60...		0.002	0.03	0.03	-	-	NVR...-2
3/8"	0.63	0.5-1.5	48-16	3IRA60...	3ILA60...	0.002	0.03	0.04	Y13	YE3	AVR...-3 (LH)
		1.75-3.0	14-8	3IRG60...	3ILG60...	0.006	0.05	0.07			
		0.5-3.0	48-8	3IRAG60...	3ILAG60...	0.002	0.05	0.07			
3/8" SCB	0.63	0.5-1.5	48-16	3JIRA60...		0.002	0.02	0.03	Y13	-	AVR...-3
		1.75-3.0	14-8	3JIRG60...		0.006	0.04	0.06			
		0.5-3.0	48-8	3JIRAG60...		0.002	0.04	0.06			
3/8" V6	0.63	0.5-2.0	48-14	3IRS60-6C...		0.001	0.06	0.10	Y13-6C	-	AVR...-3 NVRC...-3V6
1/2"	0.87	3.5-5.0	7-5	4IRN60...	4ILN60...	0.012	0.07	0.10	Y14	YE4	AVR...-4 (LH)
5/8"	1.06	5.5-6.0	4.5-4	5IRQ60...	5ILQ60...	0.012	0.07	0.11	Y15	YE5	AVR...-5 (LH)

### U Style



Insert Size		Pitch		Ordering Code		Dimensions inch			Anvil		Toolholder
IC	L inch	mm	tpi	RH+LH		r	X	Y	RH	LH	
1/2"U	0.87	5.5-8.0	4.5-3.25	4UEIU60...		0.012	0.02	0.43	Y14U	YE4U	AVR...-4U (LH)
5/8"U	1.06	6.5-9.0	4-2.75	5UEIU60...		0.015	0.04	0.54	Y15U	YE5U	AVR...-5U (LH)

### V Style



Insert Size		Pitch		Ordering Code		Dimensions inch				Toolholder
IC	L inch	mm	tpi	RH	LH	r	X	Y	T	
5/8"V	1.06	6.0-10.0	4-2.5	5VIRV60...	5VILV60...	0.014	0.04	0.17	0.31	NVR...-5V (LH)

# Partial Profile 60° (con't)



## Internal

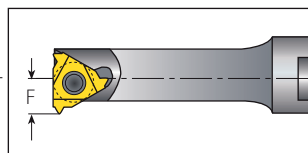
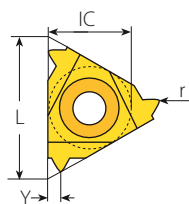
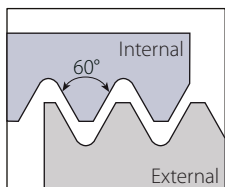

Mini-3

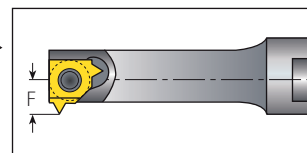
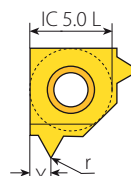

Mini-L

### Mini-3



Insert Size		Pitch		Ordering Code	Dimensions inch			Min. Bore dia.	Toolholder
IC	L inch	mm	tpi	RH	r	Y	F	inch	
4.0	6	0.5-1.25	48-20	4.0KIRA60...	0.002	0.02	0.15	0.25	.NVR.020-4.0K
6.0	10	0.5-1.5	48-16	6.0IRA60...	0.002	0.04	0.21	0.39	.NVR...-6.0

### Mini-L



Insert Size		Pitch		Ordering Code	Dimensions inch			Min. Bore dia.	Toolholder
IC	mm	tpi	RH	r	Y	F	inch		
5.0L	0.5-1.5	48-16	5LIRA60...	0.002	0.04	0.18	0.31	.NVR...-5L	

## Internal

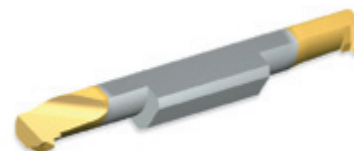
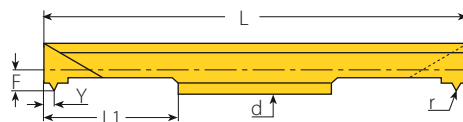
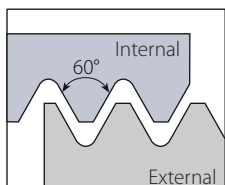

RH-Double Ended

### Micro - Double Ended

Insert dia.		Pitch		Ordering Code	Dimensions inch					Min. Bore dia.	Toolholder
d mm	mm	tpi	RH/LH	r	L1	L	F	Y	inch.		
3.0	0.5-1.0	48-24	3.0SIRF60...	0.002	0.63	1.97	0.06	0.04	0.13	SMC...-3.0	
4.0	0.5-1.0	48-24	4.0SIRF60...	0.002	0.63	1.97	0.08	0.04	0.17	SMC...-4.0	
6.0	0.5-1.5	48-16	6.0SIRA60...	0.002	0.63	1.97	0.10	0.04	0.24	SMC...-6.0	

Left Handed Tool Supplied by Request. (Example: 6.0SILA60...)

# Partial Profile 55°

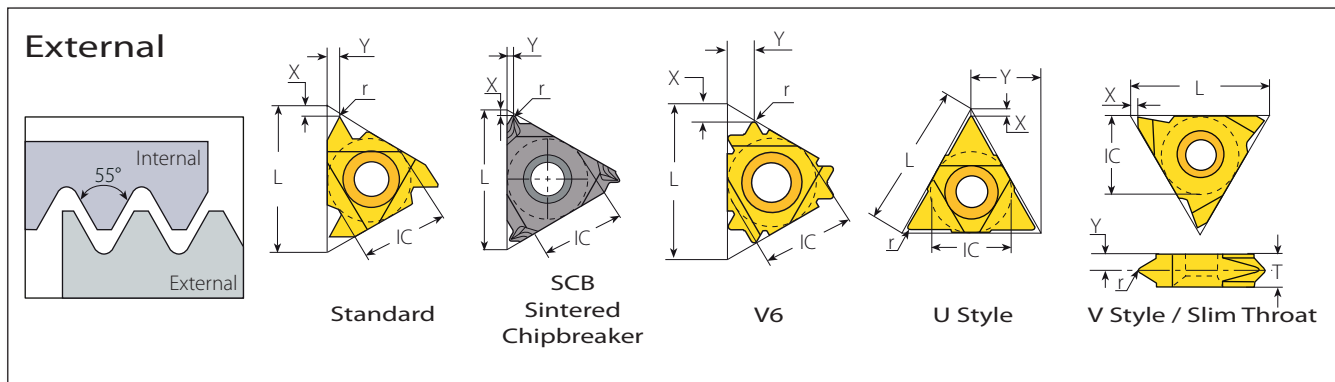

## Standard



Insert Size	Pitch			Ordering Code		Dimensions inch			Anvil		Toolholder
	IC	L inch	mm	tpi	RH	LH	r	X	Y	RH	
1/4"	0.43	0.5-1.5	48-16	2ERA55...	2ELA55...	0.002	0.03	0.04	-	-	NL...-2 (LH)
		0.5-1.5	48-16	3ERA55...	3ELA55...	0.002	0.03	0.04	-	-	-
3/8"	0.63	1.75-3.0	14-8	3ERG55...	3ELG55...	0.008	0.05	0.07	YE3	YI3	AL...-3 (LH)
		0.5-3.0	48-8	3ERAG55...	3ELAG55...	0.003	0.05	0.07	-	-	-
3/8" SCB	0.63	0.5-1.5	48-16	3JERA55...	-	0.002	0.02	0.03	-	-	-
		1.75-3.0	14-8	3JERG55...	-	0.008	0.04	0.06	YE3	-	AL...-3
		0.5-3.0	48-8	3JERAG55...	-	0.003	0.04	0.06	-	-	-
3/8"V6	0.63	-	48-14	3ERS55-6C...	-	0.002	0.07	0.11	YE3-6C	-	AL...-3
1/2"	0.87	3.5-5.0	7-5	4ERN55...	4ELN55...	0.017	0.07	0.10	YE4	YI4	AL...-4 (LH)
5/8"	1.06	5.5-6.0	4.5-4	5ERQ55...	5ELQ55...	0.024	0.08	0.11	YE5	YI5	AL...-5 (LH)

## U Style



Insert Size	Pitch			Ordering Code		Dimensions inch			Anvil		Toolholder
	IC	L inch	mm	tpi	RH+LH	r	X	Y	RH	LH	
1/2"U	0.87	5.5-8.0	4.5-3.25	-	4UEIU55...	0.024	0.04	0.43	YE4U	YI4U	AL...-4U (LH)
5/8"U	1.06	6.5-9.0	4-2.75	-	5UEIU55...	0.031	0.05	0.54	YE5U	YI5U	AL...-5U (LH)

## Slim Throat



Insert Size	Pitch			Ordering Code		Dimensions inch				Toolholder	
	IC	L inch	mm	tpi	RH	LH	r	X	Y		T
1/4"V	0.43	0.5-1.5	48-16	2VERA55...	2VELA55...	0.002	0.03	0.11	0.13	-	NL...-2V (LH)
		0.5-1.5	48-16	3VERA55...	3VELA55...	0.002	0.04	0.11	0.14	-	-
3/8"V	0.63	1.75-3.0	14-8	3VERG55...	3VELG55...	0.008	0.04	0.07	0.14	-	NL...-3V (LH)
		0.5-3.0	48-8	3VERAG55...	3VELAG55...	0.003	0.04	0.07	0.14	-	-
1/2"V	0.87	3.5-5.0	7-5	4VERN55...	4VELN55...	0.017	0.04	0.09	0.19	-	NL...-4V (LH)

## V Style



Insert Size	Pitch			Ordering Code		Dimensions inch				Toolholder	
	IC	L inch	mm	tpi	RH	LH	r	X	Y		T
5/8"V	1.06	6.0-9.0	4-2.75	-	5VERV55...	5VELV55...	0.028	0.04	0.17	0.31	NL...-5V-8 (LH)

# Partial Profile 55° (con't)

## Internal

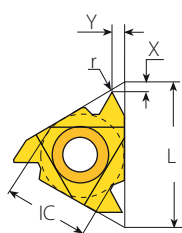
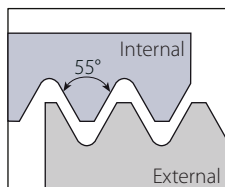

Standard

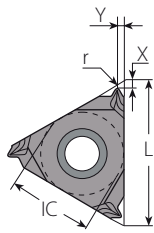

SCB  
Sintered  
Chipbreaker

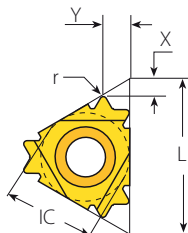

V6

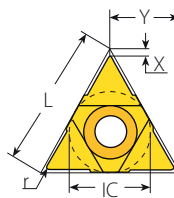

U Style

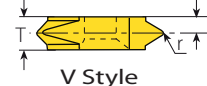
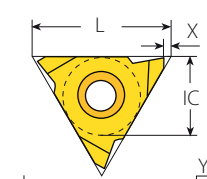

V Style

## Standard

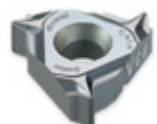

SCB



V6

Insert Size		Pitch		Ordering Code		Dimensions inch			Anvil		Toolholder
IC	L inch	mm	tpi	RH	LH	r	X	Y	RH	LH	
1/4"	0.43	0.5-1.5	48-16	2IRA55...	2ILA55...	0.002	0.03	0.04	-	-	NVR..-2 (LH)
1/4" SCB	0.43	0.5-1.5	48-16	2JIRA55...		0.002	0.02	0.03	-	-	NVR..-2
3/8"	0.63	0.5-1.5	48-16	3IRA55...	3ILA55...	0.002	0.03	0.04	YI3	YE3	AVR..-3 (LH)
		1.75-3.0	14-8	3IRG55...	3ILG55...	0.008	0.05	0.07			
		0.5-3.0	48-8	3IRAG55...	3ILAG55...	0.003	0.05	0.07			
3/8" SCB	0.63	0.5-1.5	48-16	3JIRA55...		0.002	0.02	0.03	YI3	-	AVR..-3
		1.75-3.0	14-8	3JIRG55...		0.008	0.04	0.06			
		0.5-3.0	48-8	3JIRAG55...		0.003	0.04	0.06			
3/8" V6	0.63	-	48-16	3IRS55-6C...		0.002	0.06	0.10	YI3-6C	-	AVR..-3 NVR..-3V6
1/2"	0.87	3.5-5.0	7-5	4IRN55...	4ILN55...	0.017	0.07	0.10	YI4	YE4	AVR..-4 (LH)
5/8"	1.06	5.5-6.0	4.5-4	5IRQ55...	5ILQ55...	0.024	0.08	0.11	YI5	YE5	AVR..-5 (LH)

## U Style



Insert Size		Pitch		Ordering Code		Dimensions inch			Anvil		Toolholder
IC	L inch	mm	tpi	RH+LH		r	X	Y	RH	LH	
1/2"U	0.87	5.5-8.0	4.5-3.25	4UEIU55...		0.024	0.04	0.43	YI4U	YE4U	AVR..-4U (LH)
5/8"U	1.06	6.5-9.0	4-2.75	5UEIU55...		0.031	0.05	0.54	YI5U	YE5U	AVR..-5U (LH)

## V Style



Insert Size		Pitch		Ordering Code		Dimensions inch				Toolholder
IC	L inch	mm	tpi	RH	LH	r	X	Y	T	
5/8"V	1.06	6.0-9.0	4-2.75	5VIRV55...	5VILV55...	0.028	0.04	0.17	0.31	NVR..-5V (LH)

## Partial Profile 55° (con't)



### Internal

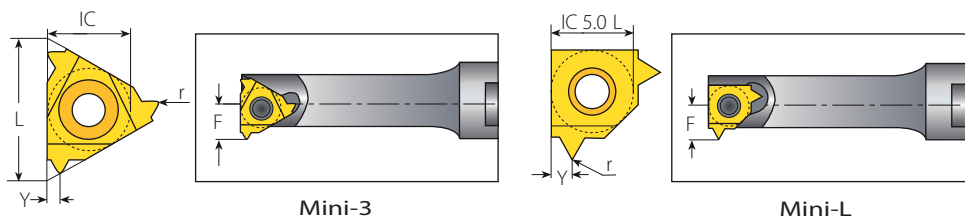
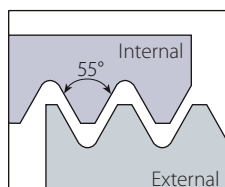

Mini-3

Mini-L

### Mini-3



Insert Size		Pitch		Ordering Code	Dimensions inch			Min. Bore dia.	Toolholder
IC	L inch	mm	tpi	RH	r	Y	F	inch	
4.0	0.24	0.5-1.25	48-20	4.0KIRA55...	0.002	0.02	0.15	0.25	.NVR. 020-4.0K
6.0	0.39	0.5-1.50	48-16	6.0IRA55...	0.002	0.04	0.21	0.39	.NVR...-6.0

### Mini-L



Insert Size		Pitch		Ordering Code	Dimensions inch			Min. Bore dia.	Toolholder
IC	mm	tpi	RH	r	Y	F	inch		
5.0L	0.5-1.5	48-16	5LIRA55...	0.002	0.04	0.18	0.31	.NVR...-5L	

## Partial Profile 55°

### Internal

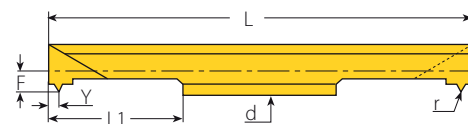
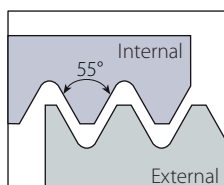

RH-Double Ended

### Micro - Double Ended

Insert dia.		Pitch		Ordering Code	Dimensions inch					Min. Bore dia.	Toolholder
d mm	mm	tpi	RH/LH	r	L1	L	F	Y	inch		
3.0	0.5-1.0	48-24	3.0SIRF55...	0.002	0.63	1.97	0.06	0.04	0.13	SMC...-3.0	
4.0	0.5-1.0	48-24	4.0SIRF55...	0.002	0.63	1.97	0.08	0.04	0.17	SMC...-4.0	
6.0	0.5-1.5	48-16	6.0SIRA55...	0.002	0.63	1.97	0.10	0.04	0.24	SMC...-6.0	

Left Handed Tool Supplied by Request. (Example: 6.0SILA55...)

# American UN - UNC, UNF, UNEF, UNS

## External

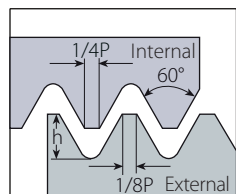

Defined by: ANSI B1.1:74  
Tolerance class: 2A/2B

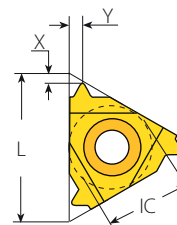

Standard

## Standard

Insert Size		Pitch	Ordering Code		Dimensions inch			Anvil		Toolholder
IC	L inch	tpi	RH	LH	h min	X	Y	RH	LH	
1/4"	0.43	72	2ER72UN...	2EL72UN...	0.009	0.03	0.02	-	-	NL...-2 (LH)
		64	2ER64UN...	2EL64UN...	0.009	0.03	0.02			
		56	2ER56UN...	2EL56UN...	0.011	0.03	0.02			
		48	2ER48UN...	2EL48UN...	0.013	0.02	0.02			
		44	2ER44UN...	2EL44UN...	0.014	0.02	0.02			
		40	2ER40UN...	2EL40UN...	0.015	0.02	0.02			
		36	2ER36UN...	2EL36UN...	0.017	0.02	0.02			
		32	2ER32UN...	2EL32UN...	0.019	0.02	0.02			
		28	2ER28UN...	2EL28UN...	0.022	0.02	0.03			
		27	2ER27UN...	2EL27UN...	0.023	0.03	0.03			
		24	2ER24UN...	2EL24UN...	0.026	0.03	0.03			
		20	2ER20UN...	2EL20UN...	0.031	0.03	0.04			
		18	2ER18UN...	2EL18UN...	0.034	0.03	0.04			
		16	2ER16UN...	2EL16UN...	0.038	0.04	0.04			
		14	2ER14UN...	2EL14UN...	0.044	0.04	0.04			
		3/8"	0.63	80	3ER80UN...	3EL80UN...	0.007			
72	3ER72UN...			3EL72UN...	0.009	0.03	0.02			
64	3ER64UN...			3EL64UN...	0.009	0.03	0.02			
56	3ER56UN...			3EL56UN...	0.011	0.03	0.02			
48	3ER48UN...			3EL48UN...	0.013	0.02	0.02			
44	3ER44UN...			3EL44UN...	0.014	0.02	0.02			
40	3ER40UN...			3EL40UN...	0.015	0.02	0.02			
36	3ER36UN...			3EL36UN...	0.017	0.02	0.02			
32	3ER32UN...			3EL32UN...	0.019	0.02	0.02			
28	3ER28UN...			3EL28UN...	0.022	0.02	0.03			
27	3ER27UN...			3EL27UN...	0.023	0.03	0.03			
24	3ER24UN...			3EL24UN...	0.026	0.03	0.03			
20	3ER20UN...			3EL20UN...	0.031	0.03	0.04			
18	3ER18UN...			3EL18UN...	0.034	0.03	0.04			
16	3ER16UN...			3EL16UN...	0.038	0.04	0.04			
14	3ER14UN...			3EL14UN...	0.044	0.04	0.05			
13	3ER13UN...	3EL13UN...	0.047	0.04	0.05					
12	3ER12UN...	3EL12UN...	0.051	0.04	0.06					
11.5	3ER11.5UN...	3EL11.5UN...	0.053	0.04	0.06					
11	3ER11UN...	3EL11UN...	0.056	0.04	0.06					
10	3ER10UN...	3EL10UN...	0.061	0.04	0.06					
9	3ER9UN...	3EL9UN...	0.068	0.05	0.07					
8	3ER8UN...	3EL8UN...	0.077	0.05	0.06					



continued on next page ▶

# American UN - UNC, UNF, UNEF, UNS (con't)



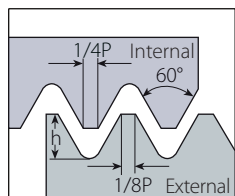

## External

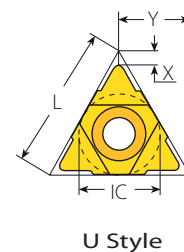
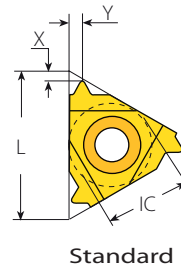
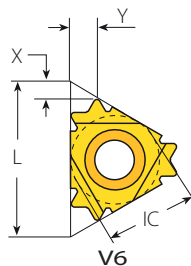
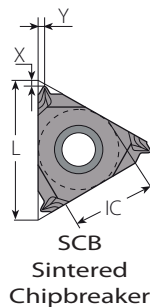

Defined by: ANSI B1.1:74  
 Tolerance class: 2A/2B



## Standard (con't)

Insert Size		Pitch	Ordering Code		Dimensions inch			Anvil		Toolholder
IC	L inch	tpi	RH	LH	h min	X	Y	RH	LH	
 SCB 3/8" SCB	0.63	36	3JER36UN...		0.017	0.05	0.02	YE3	-	AL...-3
		32	3JER32UN...		0.019	0.05	0.02			
		28	3JER28UN...		0.022	0.03	0.03			
		24	3JER24UN...		0.026	0.03	0.03			
		20	3JER20UN...		0.031	0.03	0.03			
		18	3JER18UN...		0.034	0.03	0.03			
		16	3JER16UN...		0.038	0.03	0.03			
		14	3JER14UN...		0.044	0.05	0.06			
		13	3JER13UN...		0.047	0.05	0.06			
		12	3JER12UN...		0.051	0.05	0.06			
		10	3JER10UN...		0.061	0.05	0.06			
9	3JER9UN...		0.068	0.05	0.06					
8	3JER8UN...		0.077	0.05	0.06					
 V6 3/8" V6	0.63	32	3ER32UN-6C...		0.019	0.08	0.07	YE3-6C	-	AL...-3
		28	3ER28UN-6C...		0.022	0.08	0.08			
		24	3ER24UN-6C...		0.026	0.07	0.08			
		20	3ER20UN-6C...		0.031	0.07	0.08			
		18	3ER18UN-6C...		0.034	0.07	0.09			
		16	3ER16UN-6C...		0.038	0.07	0.09			
		14	3ER14UN-6C...		0.044	0.07	0.11			
13	3ER13UN-6C...		0.047	0.07	0.11					
12	3ER12UN-6C...		0.051	0.07	0.09					
 1/2"	0.87	7	4ER7UN...	4EL7UN...	0.087	0.06	0.09	YE4	YI4	AL...-4 (LH)
		6	4ER6UN...	4EL6UN...	0.102	0.06	0.09			
		5	4ER5UN...	4EL5UN...	0.123	0.07	0.10			
 5/8"	1.06	4.5	5ER4.5UN...	5EL4.5UN...	0.136	0.07	0.11	YE5	YI5	AL...-5 (LH)
		4	5ER4UN...	5EL4UN...	0.153	0.08	0.12			

## U Style



Insert Size		Pitch	Ordering Code	Dimensions inch			Anvil		Toolholder
IC	L inch	tpi	RH+LH	h min	X	Y	RH	LH	
1/2"U	0.87	4.5	4UE4.5UN...	0.136	0.08	0.43	YE4U	YI4U	AL...-4U (LH)
		4	4UE4UN...	0.153	0.08	0.43			
5/8"U	1.06	3	5UE3UN...	0.204	0.10	0.54	YE5U	YI5U	AL...-5U (LH)

# American UN - UNC, UNF, UNEF, UNS (con't)

## External

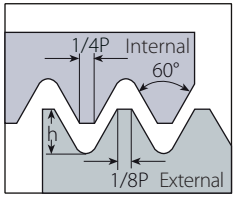

Defined by: ANSI B1.1:74  
Tolerance class: 2A/2B

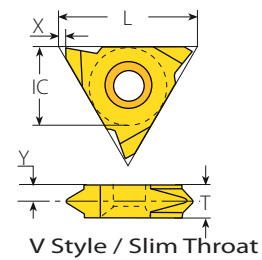

## Slim Throat

Insert Size		Pitch	Ordering Code		Dimensions inch				Toolholder
IC	L inch	tpi	RH	LH	h min	X	Y	T	
1/4"V	0.43	20	2VER20UN...	2VEL20UN...	0.031	0.03	0.09	0.13	NL..-2V (LH)
		18	2VER18UN...	2VEL18UN...	0.034	0.03	0.09	0.13	
		16	2VER16UN...	2VEL16UN...	0.038	0.03	0.09	0.13	
		14	2VER14UN...	2VEL14UN...	0.044	0.03	0.08	0.13	
		12	2VER12UN...	2VEL12UN...	0.051	0.03	0.07	0.13	
3/8"V	0.63	32	3VER32UN...	3VEL32UN...	0.019	0.04	0.12	0.14	NL..-3V (LH)
		28	3VER28UN...	3VEL28UN...	0.022	0.04	0.12	0.14	
		24	3VER24UN...	3VEL24UN...	0.026	0.04	0.11	0.14	
		20	3VER20UN...	3VEL20UN...	0.031	0.04	0.11	0.14	
		18	3VER18UN...	3VEL18UN...	0.034	0.04	0.10	0.14	
		16	3VER16UN...	3VEL16UN...	0.038	0.04	0.10	0.14	
		14	3VER14UN...	3VEL14UN...	0.044	0.04	0.09	0.14	
		12	3VER12UN...	3VEL12UN...	0.051	0.04	0.09	0.14	
1/2"V	0.87	10	3VER10UN...	3VEL10UN...	0.061	0.04	0.08	0.14	NL..-4V (LH)
		8	3VER8UN...	3VEL8UN...	0.077	0.04	0.08	0.14	
1/2"V	0.87	7	4VER7UN...	4VEL7UN...	0.087	0.04	0.10	0.19	NL..-4V (LH)



## V Style

Insert Size		Pitch	Ordering Code		Dimensions inch				Toolholder
IC	L inch	tpi	RH	LH	h min	X	Y	T	
5/8"V	1.06	4	5VER4UN...	5VEL4UN...	0.153	0.04	0.13	0.24	NL..-5V-6 (LH)
		3	5VER3UN...	5VEL3UN...	0.204	0.04	0.17	0.31	NL..-5V-8 (LH)





# American UN - UNC, UNF, UNEF, UNS (con't)

## External

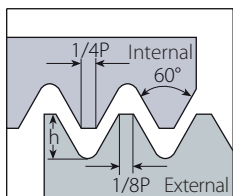

Defined by: ANSI B1.1:74  
Tolerance class: 2A/2B

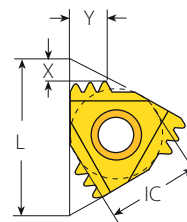

M+ Style

## M+ Style



Insert Size		Pitch	Teeth	Ordering Code	Dimensions inch			Anvil	
IC	L inch	tpi		RH	h min	X	Y	RH	Toolholder
3/8"	0.63	20	3	3ER20UN3M+...	0.031	0.09	0.13	YE3M	AL..-3
		18	2	3ER18UN2M+...	0.034	0.06	0.09		
		18	3	3ER18UN3M+...	0.034	0.09	0.14		
		16	2	3ER16UN2M+...	0.038	0.07	0.10		
		14	2	3ER14UN2M+...	0.044	0.07	0.11		
		12	2	3ER12UN2M+...	0.051	0.09	0.13		
1/2"	0.87	16	3	4ER16UN3M+...	0.038	0.10	0.16	YE4M	AL..-4
		14	2	4ER14UN2M+...	0.044	0.07	0.11		
		12	2	4ER12UN2M+...	0.051	0.09	0.13		
		12	3	4ER12UN3M+...	0.051	0.13	0.21		
		11	2	4ER11UN2M+...	0.056	0.09	0.14		
5/8"	1.06	8	2	5ER8UN2M+...	0.077	0.12	0.19	YE5M	AL..-5M

# American UN - UNC, UNF, UNEF, UNS (con't)

## Internal

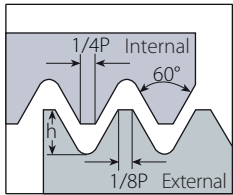

Defined by: ANSI B1.1:74  
Tolerance class: 2A/2B

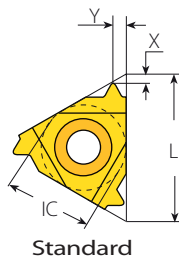

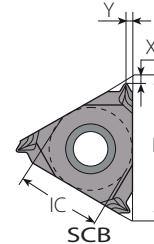

Standard

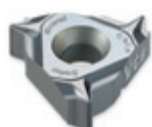

SCB  
Sintered  
Chipbreaker

## Standard (con't)

Insert Size		Pitch	Ordering Code		Dimensions inch			Anvil		Toolholder	
IC	L inch	tpi	RH	LH	h min	X	Y	RH	LH		
	1/4"	0.43	72	2IR72UN...	2IL72UN...	0.008	0.03	0.01	-	-	NVR..-2 (LH)
			64	2IR64UN...	2IL64UN...	0.009	0.03	0.02			
			56	2IR56UN...	2IL56UN...	0.010	0.03	0.02			
			48	2IR48UN...	2IL48UN...	0.012	0.02	0.02			
			44	2IR44UN...	2IL44UN...	0.013	0.02	0.02			
			40	2IR40UN...	2IL40UN...	0.015	0.02	0.02			
			36	2IR36UN...	2IL36UN...	0.016	0.02	0.02			
			32	2IR32UN...	2IL32UN...	0.018	0.02	0.02			
			28	2IR28UN...	2IL28UN...	0.020	0.02	0.03			
			27	2IR27UN...	2IL27UN...	0.021	0.03	0.03			
			24	2IR24UN...	2IL24UN...	0.024	0.03	0.03			
			20	2IR20UN...	2IL20UN...	0.029	0.03	0.04			
			18	2IR18UN...	2IL18UN...	0.032	0.03	0.04			
			16	2IR16UN...	2IL16UN...	0.036	0.04	0.04			
14	2IR14UN...	2IL14UN...	0.041	0.04	0.04						
12	2IR12UN...	2IL12UN...	0.048	0.03	0.04						
11	2IR11UN...	2IL11UN...	0.052	0.03	0.04						
	1/4" SCB	0.43	36	2JIR36UN...		0.016	0.04	0.02	-	-	NVR..-2
			32	2JIR32UN...		0.018	0.05	0.02			
			28	2JIR28UN...		0.020	0.02	0.03			
			24	2JIR24UN...		0.024	0.03	0.03			
			20	2JIR20UN...		0.029	0.02	0.03			
			18	2JIR18UN...		0.032	0.02	0.03			
16	2JIR16UN...		0.038	0.03	0.03						
	3/8"	0.63	72	3IR72UN...	3IL72UN...	0.008	0.03	0.01	Y13	YE3	AVR..-3 (LH)
			64	3IR64UN...	3IL64UN...	0.009	0.03	0.02			
			56	3IR56UN...	3IL56UN...	0.010	0.03	0.02			
			48	3IR48UN...	3IL48UN...	0.012	0.02	0.02			
			44	3IR44UN...	3IL44UN...	0.013	0.02	0.02			
			40	3IR40UN...	3IL40UN...	0.015	0.02	0.02			
			36	3IR36UN...	3IL36UN...	0.016	0.02	0.02			
			32	3IR32UN...	3IL32UN...	0.020	0.02	0.02			
			28	3IR28UN...	3IL28UN...	0.020	0.02	0.03			
			27	3IR27UN...	3IL27UN...	0.021	0.03	0.03			

continued on next page ▶

# American UN - UNC, UNF, UNEF, UNS (con't)

## Internal

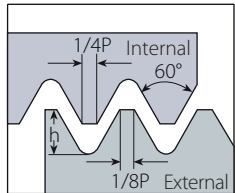

Defined by: ANSI B1.1:74  
Tolerance class: 2A/2B

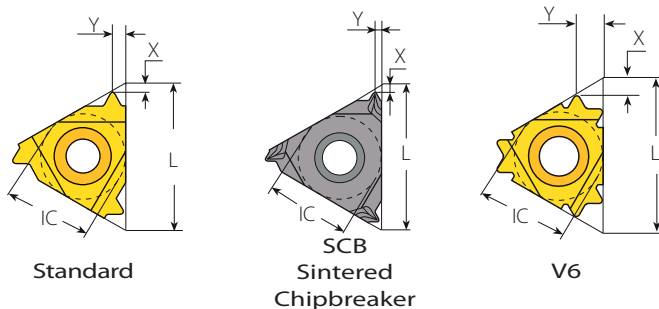

## Standard (con't)



Insert Size		Pitch	Ordering Code		Dimensions inch			Anvil		Toolholder
IC	L inch	tpi	RH	LH	h min	X	Y	RH	LH	
3/8"	0.63	24	3IR24UN...	3IL24UN...	0.024	0.03	0.03	YI3	YE3	AVR...-3 (LH)
		20	3IR20UN...	3IL20UN...	0.029	0.03	0.04			
		18	3IR18UN...	3IL18UN...	0.032	0.03	0.04			
		16	3IR16UN...	3IL16UN...	0.036	0.04	0.04			
		14	3IR14UN...	3IL14UN...	0.041	0.04	0.05			
		13	3IR13UN...	3IL13UN...	0.044	0.04	0.05			
		12	3IR12UN...	3IL12UN...	0.048	0.04	0.06			
		11.5	3IR11.5UN...	3IL11.5UN...	0.050	0.04	0.06			
		11	3IR11UN...	3IL11UN...	0.052	0.04	0.06			
		10	3IR10UN...	3IL10UN...	0.058	0.04	0.06			
3/8" SCB	0.63	28	3JIR28UN...		0.020	0.02	0.03	YI3	-	AVR...-3
		24	3JIR24UN...		0.024	0.02	0.03			
		20	3JIR20UN...		0.029	0.02	0.03			
		18	3JIR18UN...		0.032	0.02	0.03			
		16	3JIR16UN...		0.036	0.03	0.03			
		14	3JIR14UN...		0.041	0.04	0.06			
		13	3JIR13UN...		0.044	0.04	0.06			
		12	3JIR12UN...		0.048	0.04	0.06			
		10	3JIR10UN...		0.058	0.04	0.06			
		9	3JIR9UN...		0.064	0.04	0.06			
3/8" V6	0.63	32	3IR32UN-6C...		0.020	0.08	0.07	YI3-6C	-	AVR...-3 NVRC...-3V6
		28	3IR28UN-6C...		0.020	0.07	0.07			
		24	3IR24UN-6C...		0.024	0.07	0.07			
		20	3IR20UN-6C...		0.029	0.07	0.08			
		18	3IR18UN-6C...		0.032	0.07	0.08			
		16	3IR16UN-6C...		0.036	0.06	0.09			
		14	3IR14UN-6C...		0.041	0.07	0.10			
		13	3IR13UN-6C...		0.044	0.07	0.11			
1/2"	0.87	7	4IR7UN...	4IL7UN...	0.082	0.06	0.09	YI4	YE4	AVR...-4 (LH)
		6	4IR6UN...	4IL6UN...	0.096	0.06	0.09			
		5	4IR5UN...	4IL5UN...	0.115	0.06	0.09			
5/8"	1.06	4.5	5IR4.5UN...	5IL4.5UN...	0.128	0.07	0.09	YI5	YE5	AVR...-5 (LH)
		4	5IR4UN...	5IL4UN...	0.144	0.07	0.11			

# American UNC

## Internal

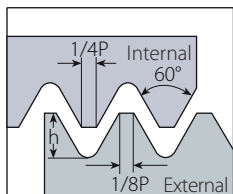

Defined by: ANSI B1.1:74  
Tolerance class: 2A/2B

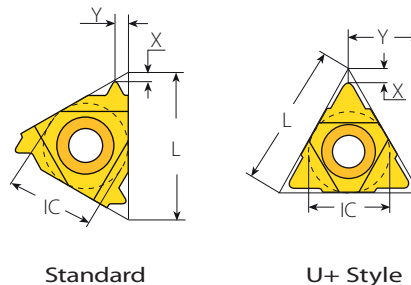

Standard

U+ Style

## Coarse Pitch



Thread	Insert Size		Ordering Code	Dimensions inch			Toolholder	Min. Bore dia. inch
	IC	L inch		RH	h min	X		
1/2 x 13UN	6.0	0.39	*6.0I13UN...158/001	0.044	0.03	0.04	BNVR0375S-6.0	0.42
9/16 x 12UN	1/4"	0.43	*2I12UN...158/002	0.048	0.04	0.04	NVRC040-2 157/001	0.47
5/8 x 11UN	1/4"U		2UI11UN...158/003	0.052	0.05	0.22	NVRC044-2U 157/002	0.53
3/4 x 10UN	3/8"	0.63	3I10UN...	0.058	0.04	0.06	NVRC050-3 157/016	0.64
7/8 x 9UN			3I9UN...	0.064	0.05	0.07	NVRC050-3 157/016	0.76
1 x 8UN			3I8UN...	0.072	0.04	0.06	NVRC0625-3	0.87
1 1/8 x 7UN	1/2"	0.87	4I7UN...	0.082	0.06	0.09	NVRC075-4	0.97
1 1/4 x 7UN			4I7UN...	0.082	0.06	0.09	NVRC075-4	1.09
1 3/8 x 6UN			4I6UN...	0.096	0.06	0.09	NVRC075-4	1.19

Left Handed Tool Supplied by Request.  
\* For LH order: 6.0IL13UN...158/016, 2IL12UN...158/017.

# American UN - UNC, UNF, UNEF, UNS (con't)

## Internal

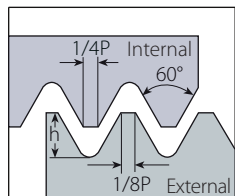

Defined by: ANSI B1.1:74  
Tolerance class: 2A/2B

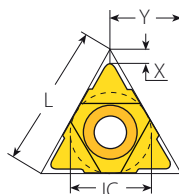

U Style

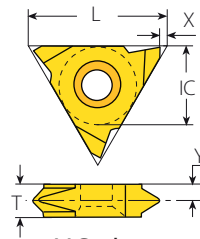

V Style

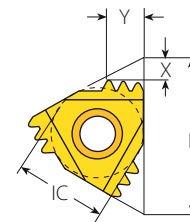

M+ Style

## U Style



Insert Size		Pitch	Ordering Code		Dimensions inch			Anvil		Toolholder
IC	L inch	tpi	RH+LH	h min	X	Y	RH	LH		
1/2"U	0.87	4.5	4UI4.5UN...	0.128	0.09	0.43	Y14U	YE4U	AVR..-4U (LH)	
		4	4UI4UN...	0.144	0.09	0.43				
5/8"U	1.06	3	5UI3UN...	0.193	0.11	0.54	Y15U	YE5U	AVR..-5U (LH)	

## V Style



Insert Size		Pitch	Ordering Code		Dimensions inch				Toolholder
IC	L inch	tpi	RH	LH	h min	X	Y	T	
5/8"V	1.06	4	5VIR4UN...	5VIL4UN...	0.144	0.04	0.13	0.24	NVR..-5V (LH)
		3	5VIR3UN...	5VIL3UN...	0.193	0.04	0.17	0.31	

## M+ Style



Insert Size		Pitch	Teeth	Ordering Code	Dimensions inch			Anvil		Toolholder
IC	L inch	tpi		RH	h min	X	Y	RH		
3/8"	0.63	12	2	3IR12UN2M+...	0.048	0.09	0.13	Y13M	AVR..-3	
		14	2	3IR14UN2M+...	0.041	0.07	0.11			
		16	2	3IR16UN2M+...	0.036	0.07	0.10			
1/2"	0.87	16	3	4IR16UN3M+...	0.036	0.10	0.16	Y14M	AVR..-4	
		14	2	4IR14UN2M+...	0.041	0.07	0.11			
		12	2	4IR12UN2M+...	0.048	0.09	0.13			
5/8"	1.06	8	2	5IR8UN2M+...	0.072	0.12	0.19	Y15M	AVR..-5M	

**Multi**plus

# American UN - UNC, UNF, UNEF, UNS (con't)



## Internal

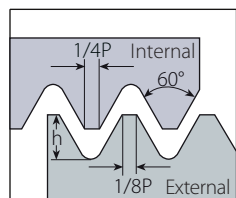

Defined by: ANSI B1.1:74  
Tolerance class: 2A/2B

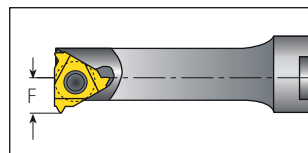
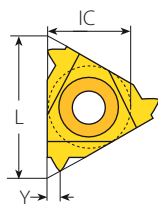

Mini-3

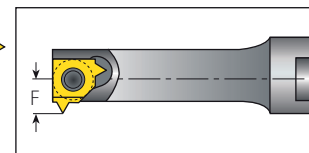
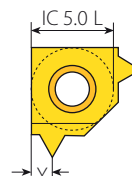

Mini-L

## Mini-3



Insert Size		Pitch	Ordering Code	Dimensions inch			Min. Bore dia.	Toolholder
IC	L inch	tpi	RH	h min	Y	F	inch	
4.0	0.24	32	4.0KIR32UN...	0.018	0.02	0.14	0.24	.NVR.020-4.0K
		28	4.0KIR28UN...	0.020	0.02	0.14	0.24	
		24	4.0KIR24UN...	0.024	0.02	0.14	0.25	
		20	4.0KIR20UN...	0.029	0.02	0.15	0.25	
		18	4.0KIR18UN...	0.032	0.03	0.15	0.25	
6.0	0.39	40	6.0IR40UN...	0.015	0.02	0.18	0.37	.NVR...-6.0
		32	6.0IR32UN...	0.018	0.02	0.18	0.37	
		28	6.0IR28UN...	0.020	0.03	0.19	0.38	
		24	6.0IR24UN...	0.024	0.03	0.19	0.38	
		20	6.0IR20UN...	0.029	0.04	0.19	0.39	
		18	6.0IR18UN...	0.032	0.04	0.20	0.39	
		16	6.0IR16UN...	0.036	0.04	0.20	0.39	
		14	6.0IR14UN...	0.041	0.04	0.20	0.39	

## Mini-L



Insert Size		Pitch	Ordering Code	Dimensions inch			Min. Bore dia.	Toolholder
IC mm		tpi	RH	h min	Y	F	inch	
5.0L		32	5LIR32UN...	0.018	0.02	0.15	0.30	.NVR...-5L
		28	5LIR28UN...	0.020	0.03	0.16	0.30	
		24	5LIR24UN...	0.024	0.03	0.16	0.30	
		20	5LIR20UN...	0.029	0.04	0.17	0.31	
		18	5LIR18UN...	0.032	0.04	0.17	0.31	
		16	5LIR16UN...	0.036	0.04	0.17	0.31	
		14	5LIR14UN...	0.041	0.04	0.18	0.31	

# American UN - UNC, UNF, UNEF, UNS (con't)



## Internal

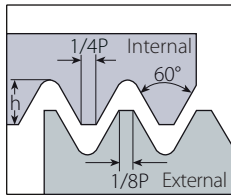

Defined by: ANSI B1.1:74  
Tolerance class: 2A/2B

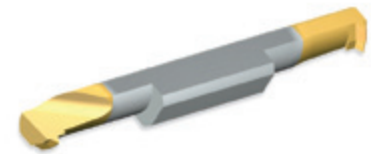
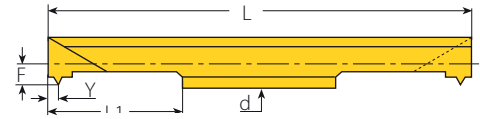

RH-Double Ended

## Micro - Double Ended

Thread	Insert dia.		Ordering Code	Dimensions inch						Min. Bore dia.	Toolholder
	d mm	mm		RH/LH	L1	L	F	Y	h min		
10-40UNS	3.0	40	3.0SIR40UN...	0.63	1.97	0.05	0.02	0.015	0.13	SMC..-3.0	
8-36UNF		36	3.0SIR36UN...	0.63	1.97	0.06	0.02	0.016	0.13		
8-32UNF		32	3.0SIR32UN...	0.63	1.97	0.06	0.02	0.018	0.13		
10-40UNS	4.0	40	4.0SIR40UN...	0.63	1.97	0.06	0.02	0.015	0.16	SMC..-4.0	
10-36UNS		36	4.0SIR36UN...	0.63	1.97	0.07	0.02	0.016	0.16		
12-32UNEF		32	4.0SIR32UN...	0.63	1.97	0.07	0.02	0.018	0.16		
12-28UNF		28	4.0SIR28UN...	0.63	1.97	0.07	0.03	0.020	0.17		
1/4"-27UNS	6.0	27	4.0SIR27UN...	0.63	1.97	0.07	0.03	0.021	0.17	SMC..-6.0	
12-24UNC		24	4.0SIR24UN...	0.63	1.97	0.08	0.03	0.024	0.17		
1/4"-20UNC		20	4.0SIR20UN...	0.63	1.97	0.08	0.03	0.029	0.17		
1/4"-32UNEF		32	6.0SIR32UN...	0.63	1.97	0.08	0.02	0.018	0.22		
5/16"-28UN		28	6.0SIR28UN...	0.63	1.97	0.08	0.03	0.020	0.22		
5/16"-27UNS		27	6.0SIR27UN...	0.63	1.97	0.08	0.03	0.021	0.22		
5/16"-24UNF	6.0	24	6.0SIR24UN...	0.63	1.97	0.09	0.03	0.024	0.22	SMC..-6.0	
5/16"-20UN		20	6.0SIR20UN...	0.63	1.97	0.09	0.04	0.029	0.23		
5/16"-18UNC		18	6.0SIR18UN...	0.63	1.97	0.09	0.04	0.032	0.23		
3/8"-16UNC		16	6.0SIR16UN...	0.63	1.97	0.10	0.04	0.036	0.24		

Left Handed Tool Supplied by Request. (Example: 6.0SIL16UN...)

# ISO Metric

## External

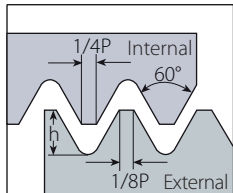

Defined by: R262 (DIN 13)  
Tolerance class: 6g/6H

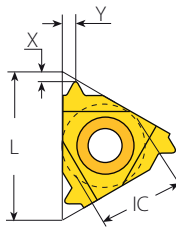

Standard

## Standard

Insert Size		Pitch	Ordering Code		Dimensions inch			Anvil		Toolholder
IC	L inch	mm	RH	LH	h min	X	Y	RH	LH	
1/4"	0.43	0.25	2ER0.25ISO...	2EL0.25ISO...	0.006	0.02	0.01	-	-	NL..-2 (LH)
		0.3	2ER0.3ISO...	2EL0.3ISO...	0.007	0.03	0.01			
		0.35	2ER0.35ISO...	2EL0.35ISO...	0.008	0.03	0.02			
		0.4	2ER0.4ISO...	2EL0.4ISO...	0.010	0.03	0.02			
		0.45	2ER0.45ISO...	2EL0.45ISO...	0.011	0.03	0.02			
		0.5	2ER0.5ISO...	2EL0.5ISO...	0.012	0.02	0.02			
		0.6	2ER0.6ISO...	2EL0.6ISO...	0.015	0.02	0.02			
		0.7	2ER0.7ISO...	2EL0.7ISO...	0.017	0.02	0.02			
		0.75	2ER0.75ISO...	2EL0.75ISO...	0.018	0.02	0.02			
		0.8	2ER0.8ISO...	2EL0.8ISO...	0.019	0.02	0.02			
		1.0	2ER1.0ISO...	2EL1.0ISO...	0.024	0.03	0.03			
		1.25	2ER1.25ISO...	2EL1.25ISO...	0.030	0.03	0.04			
		1.5	2ER1.5ISO...	2EL1.5ISO...	0.036	0.03	0.04			
		1.75	2ER1.75ISO...	2EL1.75ISO...	0.042	0.03	0.04			
		3/8"	0.63	0.25	3ER0.25ISO...	3EL0.25ISO...	0.006			
0.35	3ER0.35ISO...			3EL0.35ISO...	0.008	0.03	0.02			
0.4	3ER0.4ISO...			3EL0.4ISO...	0.010	0.03	0.02			
0.45	3ER0.45ISO...			3EL0.45ISO...	0.011	0.03	0.02			
0.5	3ER0.5ISO...			3EL0.5ISO...	0.012	0.02	0.02			
0.6	3ER0.6ISO...			3EL0.6ISO...	0.015	0.02	0.02			
0.7	3ER0.7ISO...			3EL0.7ISO...	0.017	0.02	0.02			
0.75	3ER0.75ISO...			3EL0.75ISO...	0.018	0.02	0.02			
0.8	3ER0.8ISO...			3EL0.8ISO...	0.019	0.02	0.02			
1.0	3ER1.0ISO...			3EL1.0ISO...	0.024	0.03	0.03			
1.25	3ER1.25ISO...			3EL1.25ISO...	0.030	0.03	0.04			
1.5	3ER1.5ISO...			3EL1.5ISO...	0.036	0.03	0.04			
1.75	3ER1.75ISO...			3EL1.75ISO...	0.042	0.04	0.05			
2.0	3ER2.0ISO...			3EL2.0ISO...	0.048	0.04	0.05			
2.5	3ER2.5ISO...			3EL2.5ISO...	0.060	0.04	0.06			
3.0	3ER3.0ISO...	3EL3.0ISO...	0.072	0.05	0.06					
3.5	3ER3.5ISO...	3EL3.5ISO...	0.085	0.06	0.07					



continued on next page ▶



## ISO Metric (con't)

### External

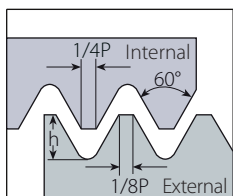

Defined by: R262 (DIN 13)  
Tolerance class: 6g/6H

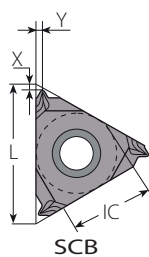

**SCB**  
Sintered  
Chipbreaker

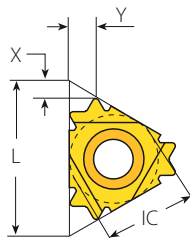

**V6**

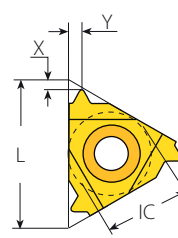

**Standard**

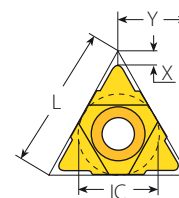

**U Style**

### Standard



SCB



V6



Insert Size		Pitch	Ordering Code		Dimensions inch			Anvil		Toolholder
IC	L inch	mm	RH	LH	h min	X	Y	RH	LH	
3/8" SCB	0.63	0.5	3JER0.5ISO...		0.012	0.05	0.02	YE3	-	AL..-3
		0.75	3JER0.75ISO...		0.018	0.05	0.02			
		0.8	3JER0.8ISO...		0.019	0.05	0.02			
		1.0	3JER1.0ISO...		0.024	0.03	0.03			
		1.25	3JER1.25ISO...		0.030	0.03	0.03			
		1.5	3JER1.5ISO...		0.036	0.03	0.03			
		1.75	3JER1.75ISO...		0.042	0.05	0.06			
		2.0	3JER2.0ISO...		0.048	0.05	0.06			
		2.5	3JER2.5ISO...		0.060	0.05	0.06			
		3.0	3JER3.0ISO...		0.072	0.05	0.06			
3/8" V6	0.63	0.5	3ER0.5ISO-6C...		0.012	0.09	0.07	YE3-6C	-	AL..-3
		0.75	3ER0.75ISO-6C...		0.018	0.08	0.07			
		0.8	3ER0.8ISO-6C...		0.019	0.08	0.07			
		1.0	3ER1.0ISO-6C...		0.024	0.07	0.08			
		1.25	3ER1.25ISO-6C...		0.030	0.07	0.08			
		1.5	3ER1.5ISO-6C...		0.036	0.07	0.09			
		1.75	3ER1.75ISO-6C...		0.042	0.07	0.10			
		2.0	3ER2.0ISO-6C...		0.048	0.07	0.11			
1/2"	0.87	3.5	4ER3.5ISO...	4EL3.5ISO...	0.085	0.06	0.09	YE4	YI4	AL..-4 (LH)
		4.0	4ER4.0ISO...	4EL4.0ISO...	0.096	0.06	0.09			
		4.5	4ER4.5ISO...	4EL4.5ISO...	0.109	0.07	0.09			
		5.0	4ER5.0ISO...	4EL5.0ISO...	0.121	0.07	0.10			
		6.0	4ER6.0ISO...	4EL6.0ISO...	0.145	0.08	0.11			
5/8"	1.06	5.5	5ER5.5ISO...	5EL5.5ISO...	0.133	0.07	0.11	YE5	YI5	AL..-5 (LH)
		6.0	5ER6.0ISO...	5EL6.0ISO...	0.145	0.08	0.11			

### U Style



Insert Size		Pitch	Ordering Code		Dimensions inch			Anvil		Toolholder
IC	L inch	mm	RH+LH	h min	X	Y	RH	LH		
1/2"U	0.87	5.0	4UE5.0ISO...	0.121	0.09	0.43	YE4U	YI4U	AL..-4U (LH)	
		5.5	4UE5.5ISO...	0.133	0.09	0.43				
		6.0	4UE6.0ISO...	0.145	0.10	0.43				
5/8"U	1.06	8.0	5UE8.0ISO...	0.193	0.09	0.54	YE5U	YI5U	AL..-5U (LH)	

## ISO Metric (con't)

### External

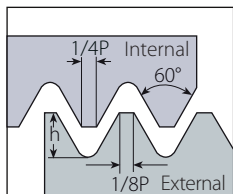

Defined by: R262 (DIN 13)  
Tolerance class: 6g/6H

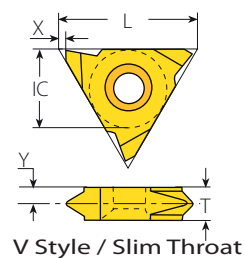

### Slim Throat

Insert Size		Pitch	Ordering Code		Dimensions inch			Toolholder	
IC	L inch	mm	RH	LH	h min	X	Y		T
1/4"V	0.43	0.75	2VER0.75ISO...	2VEL0.75ISO...	0.018	0.03	0.10	0.13	NL..-2V (LH)
		1.0	2VER1.0ISO...	2VEL1.0ISO...	0.024	0.03	0.10	0.13	
		1.5	2VER1.5ISO...	2VEL1.5ISO...	0.036	0.03	0.09	0.13	
		1.75	2VER1.75ISO...	2VEL1.75ISO...	0.042	0.03	0.08	0.13	
		2.0	2VER2.0ISO...	2VEL2.0ISO...	0.048	0.03	0.07	0.13	
3/8"V	0.63	0.35	3VER0.35ISO...	3VEL0.35ISO...	0.008	0.04	0.13	0.14	NL..-3V (LH)
		0.4	3VER0.4ISO...	3VEL0.4ISO...	0.010	0.04	0.13	0.14	
		0.5	3VER0.5ISO...	3VEL0.5ISO...	0.012	0.04	0.12	0.14	
		0.75	3VER0.75ISO...	3VEL0.75ISO...	0.018	0.04	0.12	0.14	
		0.8	3VER0.8ISO...	3VEL0.8ISO...	0.019	0.04	0.12	0.14	
		1.0	3VER1.0ISO...	3VEL1.0ISO...	0.024	0.04	0.11	0.14	
		1.25	3VER1.25ISO...	3VEL1.25ISO...	0.030	0.04	0.11	0.14	
		1.5	3VER1.5ISO...	3VEL1.5ISO...	0.036	0.04	0.10	0.14	
		1.75	3VER1.75ISO...	3VEL1.75ISO...	0.042	0.04	0.10	0.14	
		2.0	3VER2.0ISO...	3VEL2.0ISO...	0.048	0.04	0.09	0.14	
		2.5	3VER2.5ISO...	3VEL2.5ISO...	0.060	0.04	0.08	0.14	
3.0	3VER3.0ISO...	3VEL3.0ISO...	0.072	0.04	0.08	0.14			



### V Style

Insert Size		Pitch	Ordering Code		Dimensions inch			Toolholder	
IC	L inch	mm	RH	LH	h min	X	Y		T
5/8"V	1.06	5.5	5VER5.5ISO...	5VEL5.5ISO...	0.133	0.04	0.13	0.24	NL..-5V-6 (LH)
		6.0	5VER6.0ISO...	5VEL6.0ISO...	0.145	0.04	0.13	0.24	
		8.0	5VER8.0ISO...	5VEL8.0ISO...	0.193	0.04	0.17	0.31	NL..-5V-8 (LH)
		10.0	5VER10.0ISO...	5VEL10.0ISO...	0.241	0.04	0.20	0.39	NL..-5V-10 (LH)



## ISO Metric (con't)

### External

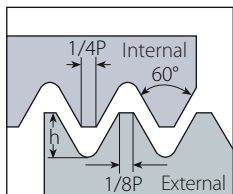

Defined by: R262 (DIN 13)  
Tolerance class: 6g/6H

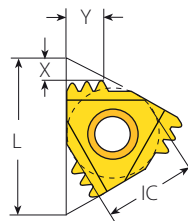

M+ Style

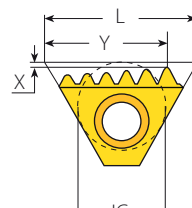

T+ Style

### M+ Style



Insert Size		Pitch	Teeth	Ordering Code	Dimensions inch			Anvil	
IC	L inch	mm		RH	h min	X	Y	RH	Toolholder
3/8"	0.63	1.0	3	3ER1.0ISO3M+...	0.024	0.07	0.10	YE3M	AL..-3
		1.5	2	3ER1.5ISO2M+...	0.036	0.06	0.09		
		2.0	2	3ER2.0ISO2M+...	0.048	0.08	0.12		
1/2"	0.87	1.5	3	4ER1.5ISO3M+...	0.036	0.10	0.15	YE4M	AL..-4
		2.0	2	4ER2.0ISO2M+...	0.048	0.08	0.12		
		2.0	3	4ER2.0ISO3M+...	0.048	0.13	0.20		
		2.5	2	4ER2.5ISO2M+...	0.060	0.10	0.15		
5/8"	1.06	3.0	2	5ER3.0ISO2M+...	0.072	0.12	0.19	YE5M	AL..-5M

### T+ Style



Insert Size		Pitch	Teeth	Ordering Code	Dimensions inch			Anvil	
IC	L inch	mm		RH	h min	X	Y	RH	Toolholder
1/2"T	0.87	1.5	8	4ER1.5ISO8T+...	0.036	0.01	0.49	Y4T	AL..-4T
		2.0	8	4ER2.0ISO8T+...	0.048	0.01	0.69		

## ISO Metric (con't)

### Internal

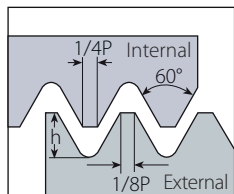

Defined by: R262 (DIN 13)  
Tolerance class: 6g/6H

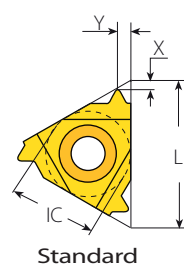

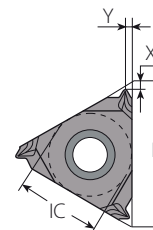

Standard

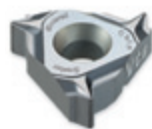

SCB  
Sintered  
Chipbreaker

### Standard

Insert Size		Pitch	Ordering Code		Dimensions inch			Anvil		Toolholder	
IC	L inch	mm	RH	LH	h min	X	Y	RH	LH		
	1/4"	0.43	0.35	2IR0.35ISO...	2IL0.35ISO...	0.008	0.03	0.01	-	-	NVR..-2 (LH)
			0.4	2IR0.4ISO...	2IL0.4ISO...	0.009	0.03	0.02			
			0.45	2IR0.45ISO...	2IL0.45ISO...	0.010	0.03	0.02			
			0.5	2IR0.5ISO...	2IL0.5ISO...	0.011	0.02	0.02			
			0.6	2IR0.6ISO...	2IL0.6ISO...	0.014	0.02	0.02			
			0.7	2IR0.7ISO...	2IL0.7ISO...	0.016	0.02	0.02			
			0.75	2IR0.75ISO...	2IL0.75ISO...	0.017	0.02	0.02			
			0.8	2IR0.8ISO...	2IL0.8ISO...	0.018	0.02	0.02			
			1.0	2IR1.0ISO...	2IL1.0ISO...	0.023	0.02	0.03			
			1.25	2IR1.25ISO...	2IL1.25ISO...	0.028	0.03	0.04			
			1.5	2IR1.5ISO...	2IL1.5ISO...	0.034	0.03	0.04			
			1.75	2IR1.75ISO...	2IL1.75ISO...	0.040	0.04	0.04			
			2.0	2IR2.0ISO...	2IL2.0ISO...	0.045	0.04	0.04			
	1/4" SCB	0.43	0.5	2JIR0.5ISO...		0.011	0.05	0.02	-	-	NVR..-2
			0.75	2JIR0.75ISO...		0.017	0.05	0.02			
			0.8	2JIR0.8ISO...		0.018	0.05	0.02			
			1.0	2JIR1.0ISO...		0.023	0.03	0.03			
			1.25	2JIR1.25ISO...		0.028	0.03	0.03			
	3/8"	0.63	0.35	3IR0.35ISO...	3IL0.35ISO...	0.008	0.03	0.01	YI3	YE3	AVR..-3 (LH)
			0.4	3IR0.4ISO...	3IL0.4ISO...	0.009	0.03	0.02			
			0.45	3IR0.45ISO...	3IL0.45ISO...	0.010	0.03	0.02			
			0.5	3IR0.5ISO...	3IL0.5ISO...	0.011	0.02	0.02			
			0.6	3IR0.6ISO...	3IL0.6ISO...	0.014	0.02	0.02			
			0.7	3IR0.7ISO...	3IL0.7ISO...	0.016	0.02	0.02			
			0.75	3IR0.75ISO...	3IL0.75ISO...	0.017	0.02	0.02			
			0.8	3IR0.8ISO...	3IL0.8ISO...	0.018	0.02	0.02			
			1.0	3IR1.0ISO...	3IL1.0ISO...	0.023	0.02	0.03			
			1.25	3IR1.25ISO...	3IL1.25ISO...	0.028	0.03	0.04			
			1.5	3IR1.5ISO...	3IL1.5ISO...	0.034	0.03	0.04			
			1.75	3IR1.75ISO...	3IL1.75ISO...	0.040	0.04	0.05			
			2.0	3IR2.0ISO...	3IL2.0ISO...	0.045	0.04	0.05			
2.5	3IR2.5ISO...	3IL2.5ISO...	0.057	0.04	0.06						
3.0	3IR3.0ISO...	3IL3.0ISO...	0.068	0.04	0.06						
3.5	3IR3.5ISO...	3IL3.5ISO...	0.080	0.05	0.06						

continued on next page ▶

## ISO Metric (con't)

### Internal

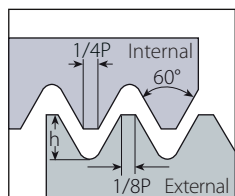

Defined by: R262 (DIN 13)  
Tolerance class: 6g/6H

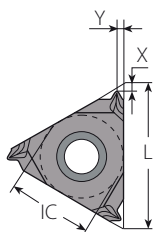

**SCB**  
Sintered  
Chipbreaker

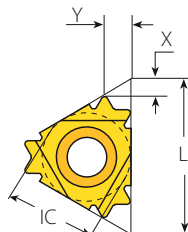

**V6**

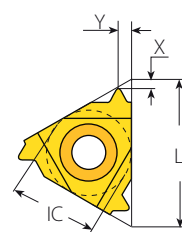

**Standard**

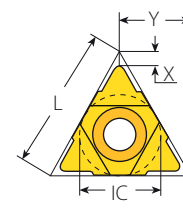

**U Style**

### Standard (con't)



Insert Size		Pitch	Ordering Code		Dimensions inch			Anvil		Toolholder
IC	L inch	mm	RH	LH	h min	X	Y	RH	LH	
3/8" SCB	0.63	1.0	3JIR1.0ISO...		0.023	0.03	0.03	Y13	-	AVR..-3
		1.25	3JIR1.25ISO...		0.028	0.03	0.03			
		1.5	3JIR1.5ISO...		0.034	0.03	0.03			
		1.75	3JIR1.75ISO...		0.040	0.04	0.06			
		2.0	3JIR2.0ISO...		0.045	0.04	0.06			
		2.5	3JIR2.5ISO...		0.057	0.04	0.06			
		3.0	3JIR3.0ISO...		0.068	0.04	0.06			
3/8" V6	0.63	0.5	3IR0.5ISO-6C...		0.011	0.08	0.07	Y13-6C	-	AVR..-3 NVRC..-3V6
		0.75	3IR0.75ISO-6C...		0.017	0.08	0.07			
		0.8	3IR0.8ISO-6C...		0.018	0.07	0.07			
		1.0	3IR1.0ISO-6C...		0.023	0.07	0.06			
		1.25	3IR1.25ISO-6C...		0.028	0.07	0.08			
		1.5	3IR1.5ISO-6C...		0.034	0.06	0.08			
		1.75	3IR1.75ISO-6C...		0.040	0.06	0.09			
1/2"	0.87	3.5	4IR3.5ISO...	4IL3.5ISO...	0.080	0.06	0.09	Y14	YE4	AVR..-4 (LH)
		4.0	4IR4.0ISO...	4IL4.0ISO...	0.091	0.06	0.09			
		4.5	4IR4.5ISO...	4IL4.5ISO...	0.102	0.06	0.09			
		5.0	4IR5.0ISO...	4IL5.0ISO...	0.114	0.06	0.09			
		6.0	4IR6.0ISO...	4IL6.0ISO...	0.136	0.07	0.10			
5/8"	1.06	4.5	5IR4.5ISO...	5IL4.5ISO...	0.102	0.06	0.09	Y15	YE5	AVR..-5 (LH)
		5.0	5IR5.0ISO...	5IL5.0ISO...	0.114	0.06	0.09			
		5.5	5IR5.5ISO...	5IL5.5ISO...	0.125	0.06	0.09			
		6.0	5IR6.0ISO...	5IL6.0ISO...	0.136	0.07	0.10			

### U Style



Insert Size		Pitch	Ordering Code	Dimensions inch			Anvil		Toolholder
IC	L inch	mm	RH+LH	h min.	X	Y	RH	LH	
1/2"U	0.87	5.5	4UI5.5ISO...	0.125	0.09	0.43	Y14U	YE4U	AVR..-4U (LH)
		6.0	4UI6.0ISO...	0.136	0.08	0.43			
5/8"U	1.06	8.0	5UI8.0ISO...	0.182	0.09	0.54	Y15U	YE5U	AVR..-5U (LH)

## ISO Metric (con't)

### Internal

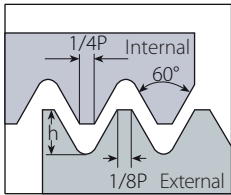

Defined by: R262 (DIN 13)  
Tolerance class: 6g/6H

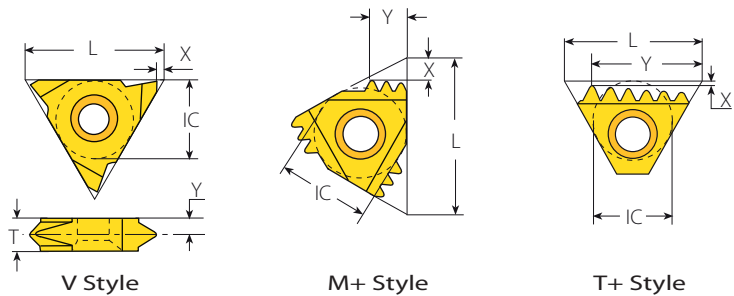

### V Style



Insert Size		Pitch	Ordering Code		Dimensions inch			Toolholder	
IC	L inch	mm	RH	LH	h min	X	Y		T
5/8"V	1.06	6.0	5VIR6.0ISO...	5VIL6.0ISO...	0.136	0.04	0.13	0.24	NVR..-5V (LH)
		8.0	5VIR8.0ISO...	5VIL8.0ISO...	0.182	0.04	0.17	0.31	
		10.0	5VIR10.0ISO...	5VIL10.0ISO...	0.227	0.04	0.20	0.39	

### M+ Style

**Multi**plus



Insert Size		Pitch	Teeth	Ordering Code	Dimensions inch			Anvil	Toolholder
IC	L inch	mm		RH	h min	X	Y	RH	
3/8"	0.63	1.0	3	3IR1.0ISO3M+...	0.023	0.07	0.10	Y13M	AVR..-3
		1.5	2	3IR1.5ISO2M+...	0.034	0.06	0.09		
		2.0	2	3IR2.0ISO2M+...	0.045	0.08	0.12		
1/2"	0.87	1.5	3	4IR1.5ISO3M+...	0.034	0.10	0.15	Y14M	AVR..-4
		2.0	2	4IR2.0ISO2M+...	0.045	0.08	0.12		
		2.0	3	4IR2.0ISO3M+...	0.045	0.13	0.20		
5/8"	1.06	3.0	2	5IR3.0ISO2M+...	0.068	0.12	0.19	Y15M	AVR..-5M

### T+ Style

**Multi**plus



Insert Size		Pitch	Teeth	Ordering Code	Dimensions inch			Anvil	Toolholder
IC	L inch	mm		RH	h min	X	Y	RH	
1/2"	0.87	1.5	8	4IR1.5ISO8T+...	0.034	0.01	0.49	Y4T	AVR..-4T
		2.0	8	4IR2.0ISO8T+...	0.045	0.01	0.69		

**ISO Metric (con't)**

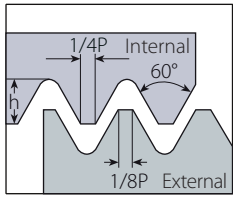
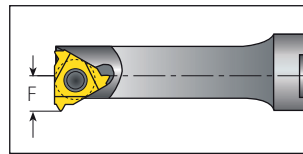
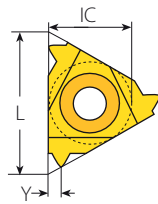
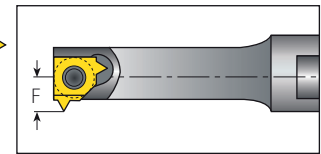
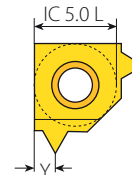
**Internal**

 Defined by: R262 (DIN 13)  
 Tolerance class: 6g/6H

**Mini-3**

**Mini-L**
**Mini-3**



Insert Size		Pitch	Ordering Code	Dimensions inch			Min. Bore dia.	Toolholder
IC	L inch	mm	RH	h min	Y	F	inch	
4.0	0.24	0.25	4.0KIR0.25ISO...	0.006	0.01	0.13	0.23	.NVR 020-4.0K
		0.5	4.0KIR0.5ISO...	0.011	0.02	0.14	0.24	
		0.75	4.0KIR0.75ISO...	0.017	0.02	0.14	0.25	
		1.0	4.0KIR1.0ISO...	0.023	0.03	0.14	0.25	
		1.25	4.0KIR1.25ISO...	0.028	0.02	0.15	0.25	
6.0	0.39	0.5	6.0IR0.5ISO...	0.011	0.02	0.17	0.37	.NVR...-6.0
		0.75	6.0IR0.75ISO...	0.017	0.02	0.18	0.37	
		1.0	6.0IR1.0ISO...	0.023	0.03	0.19	0.38	
		1.25	6.0IR1.25ISO...	0.028	0.04	0.19	0.39	
		1.5	6.0IR1.5ISO...	0.034	0.04	0.20	0.39	
		1.75	6.0IR1.75ISO...	0.040	0.04	0.20	0.39	
		2.0	6.0IR2.0ISO...	0.045	0.04	0.21	0.39	

**Mini-L**

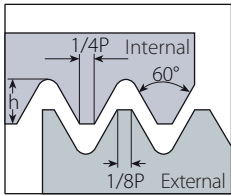

Insert Size		Pitch	Ordering Code	Dimensions inch			Min. Bore dia.	Toolholder
IC mm		mm	RH	h min	Y	F	inch	
5.0L		0.35	5LIR0.35ISO...	0.008	0.01	0.15	0.29	.NVR...-5L
		0.5	5LIR0.5ISO...	0.011	0.02	0.15	0.29	
		0.75	5LIR0.75ISO...	0.017	0.02	0.15	0.30	
		1.0	5LIR1.0ISO...	0.023	0.03	0.16	0.30	
		1.25	5LIR1.25ISO...	0.028	0.04	0.17	0.31	
		1.5	5LIR1.5ISO...	0.034	0.04	0.17	0.31	
		1.75	5LIR1.75ISO...	0.040	0.04	0.18	0.31	
		2.0	5LIR2.0ISO...	0.045	0.04	0.18	0.31	

## ISO Metric (con't)

### Internal

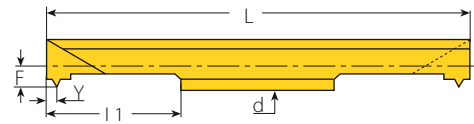

Defined by: R262 (DIN 13)  
Tolerance class: 6g/6H



RH-Double Ended

### Micro - Double Ended

Thread	Insert dia.	Pitch	Ordering Code	Dimensions inch					Min. Bore dia.	Toolholder
	d mm	mm	RH/LH	L1	L	F	Y	h min	inch	
M4 x 0.3	3.0	0.3	3.0SIR0.3ISO...	0.63	1.97	0.05	0.01	0.007	0.13	SMC..-3.0
M4 x 0.4		0.4	3.0SIR0.4ISO...	0.63	1.97	0.05	0.01	0.009	0.13	
M4 x 0.5		0.5	3.0SIR0.5ISO...	0.63	1.97	0.05	0.02	0.011	0.13	
M4 x 0.6		0.6	3.0SIR0.6ISO...	0.63	1.97	0.05	0.02	0.014	0.13	
M4.5 x 0.7		0.7	3.0SIR0.7ISO...	0.63	1.97	0.06	0.02	0.016	0.13	
M4.5 x 0.75		0.75	3.0SIR0.75ISO...	0.63	1.97	0.06	0.02	0.017	0.13	
M5 x 0.8		0.8	3.0SIR0.8ISO...	0.63	1.97	0.06	0.02	0.018	0.13	
M5 x 0.4	4.0	0.4	4.0SIR0.4ISO...	0.63	1.97	0.06	0.01	0.009	0.16	SMC..-4.0
M5 x 0.5		0.5	4.0SIR0.5ISO...	0.63	1.97	0.06	0.02	0.011	0.16	
M5 x 0.6		0.6	4.0SIR0.6ISO...	0.63	1.97	0.07	0.02	0.014	0.16	
M5 x 0.7		0.7	4.0SIR0.7ISO...	0.63	1.97	0.07	0.02	0.016	0.16	
M5.5 x 0.75		0.75	4.0SIR0.75ISO...	0.63	1.97	0.07	0.02	0.017	0.17	
M5.5 x 0.8		0.8	4.0SIR0.8ISO...	0.63	1.97	0.07	0.02	0.018	0.17	
M6 x 1		1.0	4.0SIR1.0ISO...	0.63	1.97	0.08	0.04	0.023	0.17	
M6 x 0.5	6.0	0.5	6.0SIR0.5ISO...	0.63	1.97	0.07	0.02	0.011	0.21	SMC..-6.0
M6.5 x 0.75		0.75	6.0SIR0.75ISO...	0.63	1.97	0.08	0.02	0.017	0.22	
M7 x 1		1.0	6.0SIR1.0ISO...	0.63	1.97	0.09	0.03	0.023	0.22	
M8 x 1.25		1.25	6.0SIR1.25ISO...	0.63	1.97	0.09	0.04	0.028	0.23	
M10.5 x 1.5		1.5	6.0SIR1.5ISO...	0.63	1.97	0.10	0.04	0.034	0.24	

Left Handed Tool Supplied by Request. (Example: 3.0SIL0.3ISO...)



# Whitworth - BSW, BSP, BSF, BSB

## External

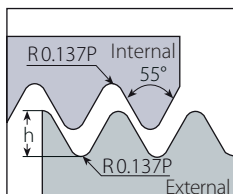

Defined by: B.S.84:1956, DIN 259, ISO228/1:1982  
Tolerance class: Medium class A

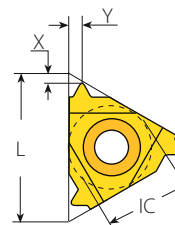

Standard

## Standard

Insert Size		Pitch	Ordering Code		Dimensions inch			Anvil		Toolholder
IC	L inch	tpi	RH	LH	h min	X	Y	RH	LH	
1/4"	0.43	72	2ER72W...	2EL72W...	0.009	0.03	0.02	-	-	NL ...-2 (LH)
		60	2ER60W...	2EL60W...	0.011	0.03	0.02			
		56	2ER56W...	2EL56W...	0.011	0.03	0.02			
		48	2ER48W...	2EL48W...	0.013	0.02	0.02			
		40	2ER40W...	2EL40W...	0.016	0.02	0.02			
		36	2ER36W...	2EL36W...	0.018	0.02	0.02			
		32	2ER32W...	2EL32W...	0.020	0.02	0.02			
		28	2ER28W...	2EL28W...	0.023	0.02	0.03			
		26	2ER26W...	2EL26W...	0.025	0.03	0.03			
		24	2ER24W...	2EL24W...	0.027	0.03	0.03			
		22	2ER22W...	2EL22W...	0.029	0.03	0.04			
		20	2ER20W...	2EL20W...	0.032	0.03	0.04			
		19	2ER19W...	2EL19W...	0.034	0.03	0.04			
		18	2ER18W...	2EL18W...	0.035	0.03	0.04			
3/8"	0.63	72	3ER72W...	3EL72W...	0.009	0.03	0.02	YE3	YI3	AL...-3 (LH)
		60	3ER60W...	3EL60W...	0.011	0.03	0.02			
		56	3ER56W...	3EL56W...	0.011	0.03	0.02			
		48	3ER48W...	3EL48W...	0.013	0.02	0.02			
		40	3ER40W...	3EL40W...	0.016	0.02	0.02			
		36	3ER36W...	3EL36W...	0.018	0.02	0.02			
		32	3ER32W...	3EL32W...	0.020	0.02	0.02			
		30	3ER30W...	3EL30W...	0.022	0.02	0.03			
		28	3ER28W...	3EL28W...	0.023	0.02	0.03			
		26	3ER26W...	3EL26W...	0.025	0.03	0.03			
		24	3ER24W...	3EL24W...	0.027	0.03	0.03			
		22	3ER22W...	3EL22W...	0.029	0.03	0.04			
		20	3ER20W...	3EL20W...	0.032	0.03	0.04			
		19	3ER19W...	3EL19W...	0.034	0.03	0.04			
18	3ER18W...	3EL18W...	0.035	0.03	0.04					
16	3ER16W...	3EL16W...	0.040	0.04	0.04					
14	3ER14W...	3EL14W...	0.046	0.04	0.05					
12	3ER12W...	3EL12W...	0.054	0.04	0.06					
11	3ER11W...	3EL11W...	0.058	0.04	0.06					
10	3ER10W...	3EL10W...	0.064	0.04	0.06					
9	3ER9W...	3EL9W...	0.071	0.05	0.07					
8	3ER8W...	3EL8W...	0.080	0.05	0.06					



continued on next page ▶

# Whitworth - BSW, BSP, BSF, BSB (con't)

## External

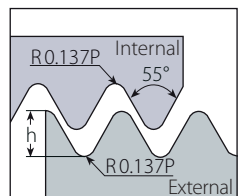

Defined by: B.S.84:1956, DIN 259, ISO228/1:1982  
Tolerance class: Medium class A

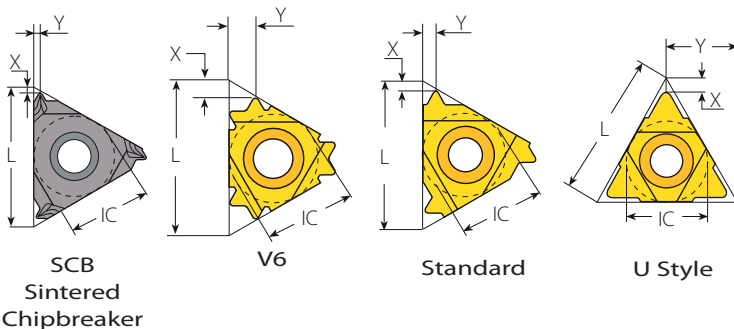

## Standard (con't)



Insert Size		Pitch	Ordering Code		Dimensions inch			Anvil		Toolholder
IC	L inch	tpi	RH	LH	h min	X	Y	RH	LH	
3/8" SCB	0.63	36	3JER36W...		0.018	0.05	0.02	YE3	-	AL..-3
		32	3JER32W...		0.020	0.05	0.02			
		28	3JER28W...		0.023	0.03	0.03			
		24	3JER24W...		0.027	0.03	0.03			
		20	3JER20W...		0.032	0.03	0.03			
		19	3JER19W...		0.034	0.03	0.03			
		18	3JER18W...		0.035	0.03	0.03			
		16	3JER16W...		0.040	0.03	0.03			
		14	3JER14W...		0.046	0.05	0.06			
		12	3JER12W...		0.054	0.05	0.06			
3/8" V6	0.63	11	3JER11W...		0.058	0.05	0.06	YE3-6C	-	AL..-3
		10	3JER10W...		0.064	0.05	0.06			
		8	3JER8W...		0.080	0.05	0.06			
		19	3ER19W-6C...		0.034	0.07	0.09			
1/2"	0.87	16	3ER16W-6C...		0.040	0.06	0.09	YE4	YI4	AL..-4 (LH)
		14	3ER14W-6C...		0.046	0.07	0.11			
		12	3ER12W-6C...		0.054	0.07	0.12			
5/8"	1.06	7	4ER7W...	4EL7W...	0.095	0.06	0.09	YE5	YI5	AL..-5 (LH)
		6	4ER6W...	4EL6W...	0.107	0.06	0.09			
		5	4ER5W...	4EL5W...	0.128	0.07	0.09			
		4.5	5ER4.5W...	5EL4.5W...	0.142	0.07	0.10			
		4	5ER4W...	5EL4W...	0.160	0.08	0.11			

## U Style



Insert Size		Pitch	Ordering Code	Dimensions inch			Anvil		Toolholder
IC	L inch	tpi	RH+LH	h min	X	Y	RH	LH	
1/2"U	0.87	4.5	4UEI4.5W...	0.142	0.09	0.43	YE4U	YI4U	AL..-4U (LH)
		4	4UEI4W...	0.160	0.07	0.43			
		3.5	4UEI3.5W...	0.183	0.08	0.43			
		3.25	4UEI3.25W...	0.197	0.08	0.43			
5/8"U	1.06	3.5	5UEI3.5W...	0.183	0.08	0.54	YE5U	YI5U	AL..-5U (LH)
		3.25	5UEI3.25W...	0.197	0.08	0.54			
		3	5UEI3W...	0.213	0.09	0.54			
		2.75	5UEI2.75W...	0.233	0.09	0.54			

# Whitworth - BSW, BSP, BSF, BSB (con't)

## External

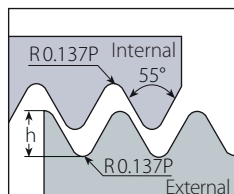

Defined by: B.S.84:1956, DIN 259, ISO228/1:1982  
 Tolerance class: Medium class A

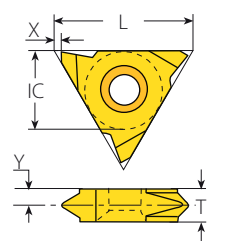

V Style / Slim Throat

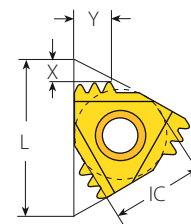

M+ Style

## Slim Throat



Insert Size		Pitch	Ordering Code		Dimensions inch				Toolholder
IC	L inch	tpi	RH	LH	h min	X	Y	T	
1/4"V	0.43	19	2VER19W...	2VEL19W...	0.034	0.03	0.09	0.13	NL..-2V (LH)
		14	2VER14W...	2VEL14W...	0.046	0.03	0.08	0.13	
		11	2VER11W...	2VEL11W...	0.058	0.03	0.07	0.13	
3/8"V	0.63	19	3VER19W...	3VEL19W...	0.034	0.04	0.11	0.14	NL..-3V (LH)
		18	3VER18W...	3VEL18W...	0.035	0.04	0.10	0.14	
		16	3VER16W...	3VEL16W...	0.040	0.04	0.10	0.14	
		14	3VER14W...	3VEL14W...	0.046	0.04	0.09	0.14	
		12	3VER12W...	3VEL12W...	0.054	0.04	0.09	0.14	
		11	3VER11W...	3VEL11W...	0.058	0.04	0.08	0.14	

## V Style



Insert Size		Pitch	Ordering Code		Dimensions inch				Toolholder
IC	L inch	tpi	RH	LH	h min	X	Y	T	
5/8"V	1.06	4	5VER4W...	5VEL4W...	0.160	0.04	0.13	0.24	NL..-5V-6 (LH)
		3	5VER3W...	5VEL3W...	0.213	0.04	0.17	0.31	NL..-5V-8 (LH)
		2.5	5VER2.5W...	5VEL2.5W...	0.256	0.04	0.20	0.39	NL..-5V-10 (LH)

## M+ Style



Insert Size		Pitch	Teeth	Ordering Code	Dimensions inch			Anvil	Toolholder
IC	L inch	tpi		RH	h min	X	Y	RH	
3/8"	0.63	28	2	3ER28W2M+...	0.023	0.05	0.06	YE3M	AL..-3
		19	2	3ER19W2M+...	0.034	0.06	0.09		
		19	3	3ER19W3M+...	0.034	0.09	0.13		
		14	2	3ER14W2M+...	0.046	0.08	0.12		
1/2"	0.87	14	3	4ER14W3M+...	0.046	0.11	0.18	YE4M	AL..-4
		11	2	4ER11W2M+...	0.058	0.09	0.14		

# Whitworth - BSW, BSP, BSF, BSB (con't)

## Internal

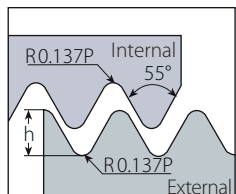

Defined by: B.S.84:1956, DIN 259, ISO228/1:1982  
Tolerance class: Medium class A

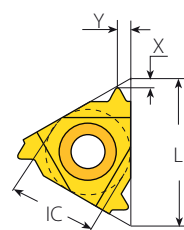

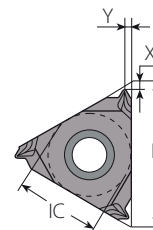

Standard

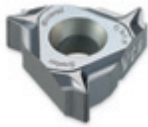

SCB  
Sintered  
Chipbreaker

## Standard

Insert Size		Pitch	Ordering Code		Dimensions inch			Anvil		Toolholder	
IC	L inch	tpi	RH	LH	h min	X	Y	RH	LH		
	1/4"	0.43	72	2IR72W...	2IL72W...	0.009	0.03	0.02	-	-	NVR..-2 (LH)
			60	2IR60W...	2IL60W...	0.011	0.03	0.02			
			56	2IR56W...	2IL56W...	0.011	0.03	0.02			
			48	2IR48W...	2IL48W...	0.013	0.02	0.02			
			40	2IR40W...	2IL40W...	0.016	0.02	0.02			
			36	2IR36W...	2IL36W...	0.018	0.02	0.02			
			32	2IR32W...	2IL32W...	0.020	0.02	0.02			
			28	2IR28W...	2IL28W...	0.023	0.02	0.03			
			26	2IR26W...	2IL26W...	0.025	0.03	0.03			
			24	2IR24W...	2IL24W...	0.027	0.03	0.03			
			22	2IR22W...	2IL22W...	0.029	0.03	0.04			
			20	2IR20W...	2IL20W...	0.032	0.03	0.04			
			19	2IR19W...	2IL19W...	0.034	0.03	0.04			
			18	2IR18W...	2IL18W...	0.035	0.03	0.04			
	1/4" SCB	0.43	36	2JIR36W...		0.018	0.05	0.02	-	-	NVR..-2
			32	2JIR32W...		0.020	0.05	0.02			
			28	2JIR28W...		0.023	0.03	0.03			
			24	2JIR24W...		0.027	0.03	0.03			
			20	2JIR20W...		0.032	0.03	0.03			
			19	2JIR19W...		0.034	0.02	0.03			
			18	2JIR18W...		0.035	0.03	0.03			
			16	2JIR16W...		0.040	0.03	0.03			
	3/8"	0.63	72	3IR72W...	3IL72W...	0.009	0.03	0.02	YI3	YE3	AVR..-3 (LH)
			60	3IR60W...	3IL60W...	0.011	0.03	0.02			
			56	3IR56W...	3IL56W...	0.011	0.03	0.02			
			48	3IR48W...	3IL48W...	0.013	0.02	0.02			
			40	3IR40W...	3IL40W...	0.016	0.02	0.02			
			36	3IR36W...	3IL36W...	0.018	0.02	0.02			
			32	3IR32W...	3IL32W...	0.020	0.02	0.02			
			30	3IR30W...	3IL30W...	0.022	0.02	0.03			

continued on next page ▶

# Whitworth - BSW, BSP, BSF, BSB (con't)

## Internal

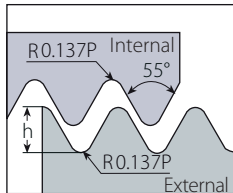

Defined by: B.S.84:1956, DIN 259, ISO228/1:1982  
 Tolerance class: Medium class A

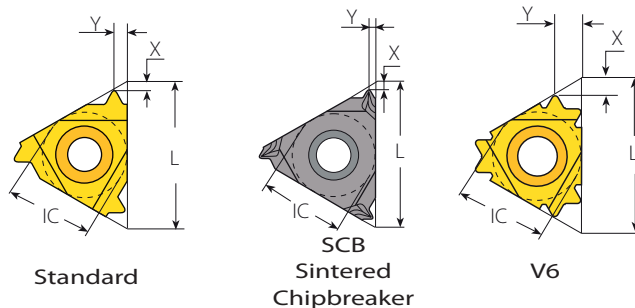

## Standard (con't)



Insert Size		Pitch	Ordering Code		Dimensions inch			Anvil		Toolholder
IC	L inch	tpi	RH	LH	h min	X	Y	RH	LH	
3/8"	0.63	28	3IR28W...	3IL28W...	0.023	0.02	0.03	Y13	YE3	AVR..-3 (LH)
		26	3IR26W...	3IL26W...	0.025	0.03	0.03			
		24	3IR24W...	3IL24W...	0.027	0.03	0.03			
		22	3IR22W...	3IL22W...	0.029	0.03	0.04			
		20	3IR20W...	3IL20W...	0.032	0.03	0.04			
		19	3IR19W...	3IL19W...	0.034	0.03	0.04			
		18	3IR18W...	3IL18W...	0.035	0.03	0.04			
		16	3IR16W...	3IL16W...	0.040	0.04	0.04			
		14	3IR14W...	3IL14W...	0.046	0.04	0.05			
		12	3IR12W...	3IL12W...	0.054	0.04	0.06			
		11	3IR11W...	3IL11W...	0.058	0.04	0.06			
		10	3IR10W...	3IL10W...	0.064	0.04	0.06			
3/8" SCB	0.63	28	3JIR28W...		0.023	0.03	0.03	Y13	-	AVR...-3
		24	3JIR24W...		0.027	0.03	0.03			
		20	3JIR20W...		0.032	0.03	0.03			
		19	3JIR19W...		0.034	0.02	0.02			
		18	3JIR18W...		0.035	0.03	0.03			
		16	3JIR16W...		0.040	0.03	0.03			
		14	3JIR14W...		0.046	0.05	0.06			
		12	3JIR12W...		0.054	0.05	0.06			
3/8" V6	0.63	19	3IR19W-6C...		0.034	0.07	0.09	Y13-6C	-	AVR..-3 NVRC..-3V6
		16	3IR16W-6C...		0.040	0.06	0.10			
		14	3IR14W-6C...		0.046	0.07	0.11			
		12	3IR12W-6C...		0.054	0.07	0.10			
1/2"	0.87	7	4IR7W...	4IL7W...	0.095	0.06	0.09	Y14	YE4	AVR..-4 (LH)
		6	4IR6W...	4IL6W...	0.107	0.06	0.09			
		5	4IR5W...	4IL5W...	0.128	0.07	0.09			
5/8"	1.06	4.5	5IR4.5W...	5IL4.5W...	0.142	0.07	0.10	Y15	YE5	AVR..-5 (LH)
		4	5IR4W...	5IL4W...	0.160	0.08	0.11			

# Whitworth - BSW, BSP, BSF, BSB (con't)

## Internal

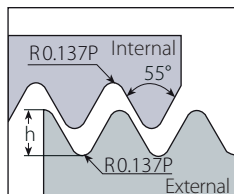

Defined by: B.S.84:1956, DIN 259, ISO228/1:1982  
Tolerance class: Medium class A

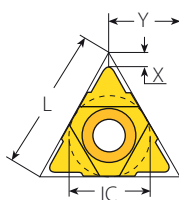

U Style

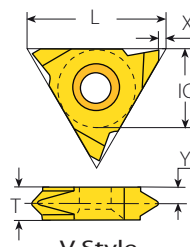

V Style

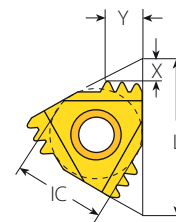

M+ Style

## U Style



Insert Size		Pitch	Ordering Code		Dimensions inch			Anvil		Toolholder
IC	L inch	tpi	RH+LH	h min	X	Y	RH	LH		
1/2"U	0.87	4.5	4UEI4.5W...	0.142	0.09	0.43	YI4U	YE4U	AVR..-4U (LH)	
		4	4UEI4W...	0.160	0.07	0.43				
		3.5	4UEI3.5W...	0.183	0.08	0.43				
		3.25	4UEI3.25W...	0.197	0.08	0.43				
5/8"U	1.06	3.5	5UEI3.5W...	0.183	0.08	0.54	YI5U	YE5U	AVR..-5U (LH)	
		3.25	5UEI3.25W...	0.197	0.08	0.54				
		3	5UEI3W...	0.213	0.09	0.54				
		2.75	5UEI2.75W...	0.233	0.09	0.54				

## V Style



Insert Size		Pitch	Ordering Code		Dimensions inch				Toolholder
IC	L inch	tpi	RH	LH	h min	X	Y	T	
5/8"V	1.06	4	5VIR4W...	5VIL4W...	0.160	0.04	0.13	0.24	NVR..-5V (LH)
		3	5VIR3W...	5VIL3W...	0.213	0.04	0.17	0.31	
		2.5	5VIR2.5W...	5VIL2.5W...	0.256	0.04	0.20	0.39	

## M+ Style



Insert Size		Pitch	Teeth	Ordering Code	Dimensions inch			Anvil	Toolholder
IC	L inch	tpi	RH	h min	X	Y	RH		
3/8"	0.63	14	2	3IR14W2M+...	0.046	0.08	0.12	YI3M	AVR..-3
1/2"	0.87	11	2	4IR11W2M+...	0.058	0.09	0.14	YI4M	AVR..-4

**Whitworth** - BSW, BSP, BSF, BSB (con't)

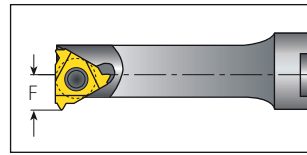
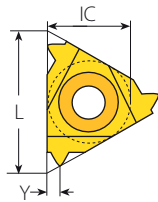
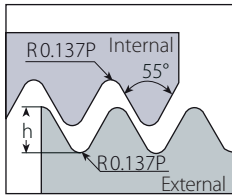
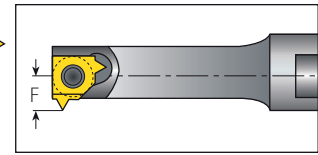
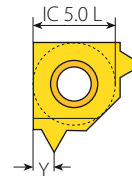
**Internal**

**Mini-3**

**Mini-L**

Defined by: B.S.84:1956, DIN 259, ISO228/1:1982  
Tolerance class: Medium class A

**Mini-3**

Insert Size		Pitch	Ordering Code	Dimensions inch			Min. Bore dia.	Toolholder
IC	L inch	tpi	RH	h min	Y	F	inch	
4.0	0.24	26	4.0KIR26W...	0.025	0.02	0.14	0.25	.NVR.020-4.0K
		22	4.0KIR22W...	0.029	0.02	0.15	0.25	
		20	4.0KIR20W...	0.032	0.03	0.15	0.25	
		19	4.0KIR19W...	0.034	0.03	0.15	0.25	
6.0	0.39	18	4.0KIR18W...	0.035	0.03	0.15	0.25	.NVR...-6.0
		28	6.0IR28W...	0.023	0.03	0.19	0.38	
		19	6.0IR19W...	0.034	0.04	0.20	0.39	
		14	6.0IR14W...	0.046	0.04	0.21	0.39	

**Mini-L**

Insert Size		Pitch	Ordering Code	Dimensions inch			Min. Bore dia.	Toolholder
IC mm		tpi	RH	h min	Y	F	inch	
5.0 L		28	5LIR28W...	0.023	0.03	0.16	0.30	.NVR... -5L
		19	5LIR19W...	0.034	0.04	0.17	0.31	
		14	5LIR14W...	0.046	0.04	0.18	0.31	

# Whitworth - BSW, BSP, BSF, BSB (con't)



## Internal

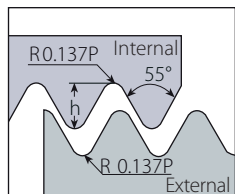

Defined by: B.S.84:1956, DIN 259, ISO228/1:1982  
Tolerance class: Medium class A

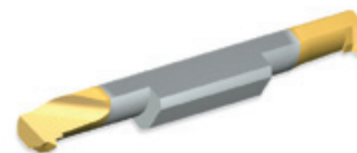
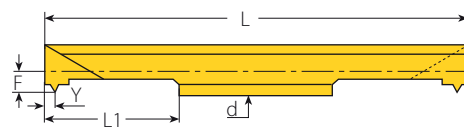

RH-Double Ended

## Micro - Double Ended

Thread	Insert dia.		Ordering Code	Dimensions inch					Min. Bore dia.		Toolholder
	d mm	tpi		RH/LH	L1	L	F	Y	h min	inch	
1/16"-28BSP	4.0	28	4.0SIR28W...	0.63	1.97	0.07	0.03	0.023	0.17	SMC..-4.0	
1/4"-26BSF		26	4.0SIR26W...	0.63	1.97	0.08	0.03	0.025	0.17		
1/4"-24BSW		24	4.0SIR24W...	0.63	1.97	0.08	0.03	0.027	0.17		
1/16"-28BSP	6.0	28	6.0SIR28W...	0.63	1.97	0.10	0.03	0.023	0.24	SMC..-6.0	
5/16"-28BSW		26	6.0SIR26W...	0.63	1.97	0.10	0.03	0.025	0.24		
5/16"-24BSW		24	6.0SIR24W...	0.63	1.97	0.10	0.03	0.027	0.24		
5/16"-22BSW		22	6.0SIR22W...	0.63	1.97	0.10	0.04	0.029	0.24		
3/8"-20BSF		20	6.0SIR20W...	0.63	1.97	0.10	0.04	0.032	0.24		
1/4"-19BSP		19	6.0SIR19W...	0.63	1.97	0.10	0.04	0.034	0.24		

Left Handed Tool Supplied by Request. (Example: 6.0SIL19W...)



# BSPT

## External

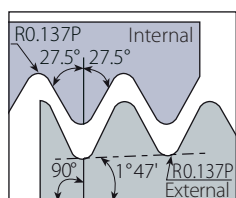

Defined by: B.S. 21:1985  
Tolerance class: Standard BSPT

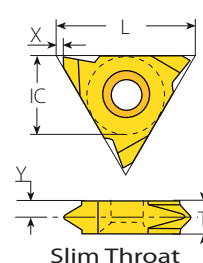
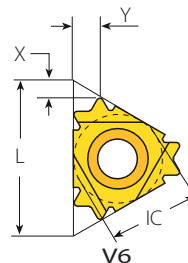
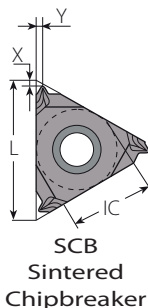
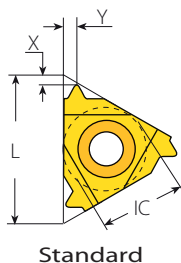

## Standard



Insert Size		Pitch	Ordering Code		Dimensions inch			Anvil		Toolholder
IC	L inch	tpi	RH	LH	h min	X	Y	RH	LH	
1/4"	0.43	28	2ER28BSPT...	2EL28BSPT...	0.023	0.02	0.02	-	-	NL...-2 (LH)
		19	2ER19BSPT...	2EL19BSPT...	0.034	0.03	0.04	-	-	
		14	2ER14BSPT...	2EL14BSPT...	0.046	0.04	0.04	-	-	
3/8"	0.63	28	3ER28BSPT...	3EL28BSPT...	0.023	0.02	0.02	YE3	YI3	AL...-3 (LH)
		19	3ER19BSPT...	3EL19BSPT...	0.034	0.03	0.04			
		14	3ER14BSPT...	3EL14BSPT...	0.046	0.04	0.05			
3/8" SCB	0.63	28	3JER28BSPT...		0.023	0.03	0.03	YE3	-	AL...-3
		19	3JER19BSPT...		0.034	0.03	0.03			
		14	3JER14BSPT...		0.046	0.05	0.06			
3/8" V6	0.63	19	3ER19BSPT-6C...		0.034	0.07	0.09	YE3-6C	-	AL...-3
		14	3ER14BSPT-6C...		0.046	0.07	0.11			

## Slim Throat



Insert Size		Pitch	Ordering Code		Dimensions inch			Toolholder	
IC	L inch	tpi	RH	LH	h min	X	Y		T
3/8"V	0.63	28	3VER28BSPT...	3VEL28BSPT...	0.023	0.04	0.12	0.14	NL...-3V (LH)
		19	3VER19BSPT...	3VEL19BSPT...	0.034	0.04	0.11	0.14	
		14	3VER14BSPT...	3VEL14BSPT...	0.046	0.04	0.09	0.14	
		11	3VER11BSPT...	3VEL11BSPT...	0.058	0.04	0.08	0.14	

# BSPT (con't)

## Internal

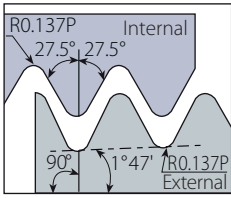

Defined by: B.S. 21:1985  
Tolerance class: Standard BSPT

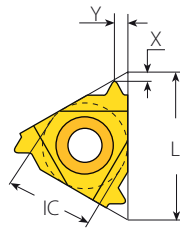

Standard

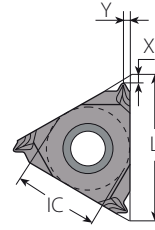

SCB  
Sintered  
Chipbreaker

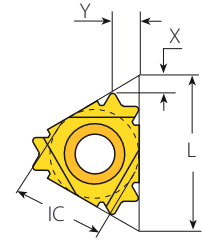

V6

## Standard



SCB



V6

Insert Size		Pitch	Ordering Code			Dimensions inch			Anvil		Toolholder
IC	L inch	tpi	RH	LH	h min	X	Y	RH	LH		
1/4"	0.43	28	2IR28BSPT...	2IL28BSPT...	0.023	0.02	0.02	-	-	NVR..-2 (LH)	
		19	2IR19BSPT...	2IL19BSPT...	0.034	0.03	0.04				
		14	2IR14BSPT...	2IL14BSPT...	0.046	0.04	0.04				
1/4" SCB	0.43	28	2JIR28BSPT...		0.023	0.03	0.03	-	-	NVR..-2	
		19	2JIR19BSPT...		0.034	0.03	0.03				
3/8"	0.63	28	3IR28BSPT...	3IL28BSPT...	0.023	0.02	0.02	Y13	YE3	AVR..-3 (LH)	
		19	3IR19BSPT...	3IL19BSPT...	0.034	0.03	0.04				
		14	3IR14BSPT...	3IL14BSPT...	0.046	0.04	0.05				
3/8" SCB	0.63	11	3IR11BSPT...	3IL11BSPT...	0.058	0.04	0.06	Y13	-	AVR..-3	
		28	3JIR28BSPT...		0.023	0.03	0.03				
		19	3JIR19BSPT...		0.034	0.03	0.03				
3/8" V6	0.63	14	3JIR14BSPT...		0.046	0.05	0.06	Y13-6C	-	AVR..-3 NVR...-3V6	
		19	3IR19BSPT-6C...		0.034	0.07	0.09				
		14	3IR14BSPT-6C...		0.046	0.07	0.11				

**BSPT (con't)**

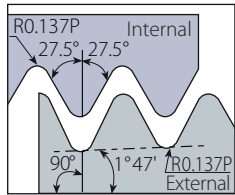
**Internal**

Defined by: B.S. 21:1985  
Tolerance class: Standard BSPT

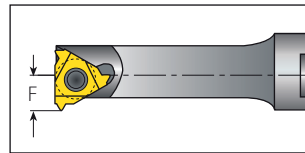
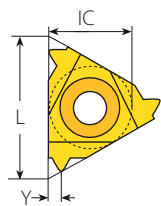
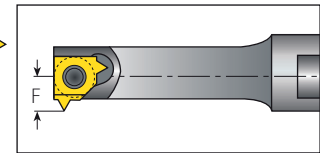
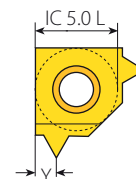
**Mini-3**

**Mini-L**
**Mini-3**



Insert Size		Pitch	Ordering Code	Dimensions inch			Min. Bore dia.	Toolholder
IC	L inch	tpi	RH	h min	Y	F	inch	
4.0	0.24	28	4.0KIR28BSPT...	0.023	0.02	0.14	0.25	.NVR.020-4.0K
6.0	0.39	28	6.0IR28BSPT...	0.023	0.02	0.19	0.38	.NVR...-6.0
		19	6.0IR19BSPT...	0.034	0.04	0.20	0.39	
		14	6.0IR14BSPT...	0.046	0.05	0.21	0.39	

**Mini-L**

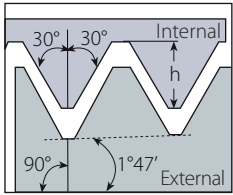

Insert Size		Pitch	Ordering Code	Dimensions inch			Min. Bore dia.	Toolholder
IC mm		tpi	RH	h min	Y	F	inch	
5.0L		28	5LIR28BSPT...	0.023	0.02	0.16	0.31	.NVR...-5L
		19	5LIR19BSPT...	0.034	0.04	0.17	0.31	
		14	5LIR14BSPT...	0.046	0.05	0.18	0.31	

# NPT

## External

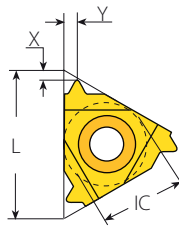

Defined by: USAS B2.1:1968  
Tolerance class: Standard NPT



Standard

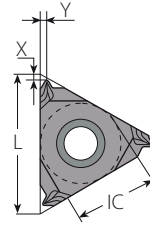

SCB  
Sintered  
Chipbreaker

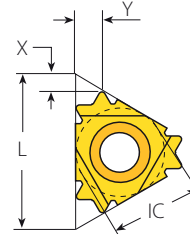

V6

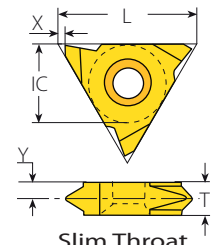

Slim Throat

## Standard

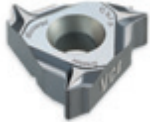

SCB



V6

Insert Size		Pitch	Ordering Code			Dimensions inch			Anvil		Toolholder
IC	L inch	tpi	RH	LH	h min	X	Y	RH	LH		
1/4"	0.43	27	2ER27NPT...	2EL27NPT...	0.026	0.03	0.03	-	-	NL...-2 (LH)	
		18	2ER18NPT...	2EL18NPT...	0.040	0.03	0.04	-	-		
		14	2ER14NPT...	2EL14NPT...	0.052	0.03	0.04	-	-		
3/8"	0.63	27	3ER27NPT...	3EL27NPT...	0.026	0.03	0.03	YE3	YI3	AL...-3 (LH)	
		18	3ER18NPT...	3EL18NPT...	0.040	0.03	0.04				
		14	3ER14NPT...	3EL14NPT...	0.052	0.04	0.05				
		11.5	3ER11.5NPT...	3EL11.5NPT...	0.065	0.04	0.06				
3/8" SCB	0.63	27	3JER27NPT...		0.026	0.02	0.03	YE3	-	AL...-3	
		18	3JER18NPT...		0.040	0.02	0.03				
		14	3JER14NPT...		0.052	0.04	0.06				
		11.5	3JER11.5NPT...		0.065	0.04	0.06				
3/8" V6	0.63	14	3ER14NPT-6C...		0.052	0.07	0.12	YE3-6C	-	AL...-3	

## Slim Throat



Insert Size		Pitch	Ordering Code		Dimensions inch				Toolholder
IC	L inch	tpi	RH	LH	h min	X	Y	T	
1/4"V	0.43	27	2VER27NPT...	2VEL27NPT...	0.026	0.03	0.08	0.13	NL...-2V (LH)
		18	2VER18NPT...	2VEL18NPT...	0.040	0.03	0.07	0.13	
		14	2VER14NPT...	2VEL14NPT...	0.052	0.03	0.07	0.13	
		11.5	2VER11.5NPT...	2VEL11.5NPT...	0.065	0.03	0.08	0.13	
3/8"V	0.63	27	3VER27NPT...	3VEL27NPT...	0.026	0.04	0.11	0.14	NL...-3V (LH)
		18	3VER18NPT...	3VEL18NPT...	0.040	0.04	0.10	0.14	
		11.5	3VER11.5NPT...	3VEL11.5NPT...	0.065	0.04	0.08	0.14	

## NPT (con't)

### External

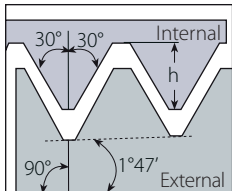

Defined by: USAS B2.1:1968  
 Tolerance class: Standard NPT

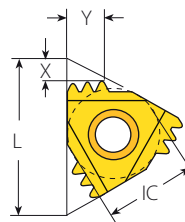

M+ Style

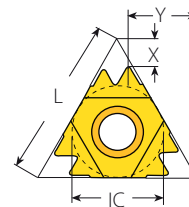

Z+ Style

**Multi**plus

### M+ Style



Insert Size		Pitch	Teeth	Ordering Code	Dimensions inch			Anvil	Toolholder
IC	L inch	tpi		RH	h min	X	Y	RH	
3/8"	0.63	14	2	3ER14NPT2M+...	0.052	0.08	0.12	YE3M	AL..-3
1/2"	0.87	11.5	2	4ER11.5NPT2M+...	0.065	0.09	0.13	YE4M	AL..-4
5/8"	1.06	11.5	3	5ER11.5NPT3M+...	0.065	0.14	0.22	YE5M	AL..-5M
		8	2	5ER8NPT2M+...	0.095	0.12	0.19		

**Multi**plus

### Z+ Style



Insert Size		Pitch	Teeth	Ordering Code	Dimensions inch			Anvil	Toolholder
IC	L inch	tpi		RH	h min	X	Y	RH	
1/2"	0.87	11.5	2	4ER11.5NPT2Z+...	0.065	0.11	0.39	YE4Z	AL..-4Z
		8	2	4ER8NPT2Z+...	0.095	0.13	0.38		

# NPT (con't)

## Internal

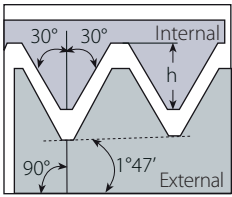

Defined by: USAS B2.1:1968  
Tolerance class: Standard NPT

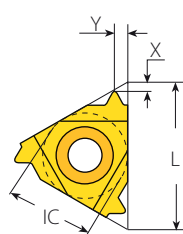

Standard

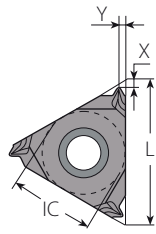

SCB  
Sintered  
Chipbreaker

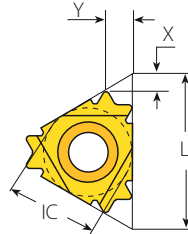

V6

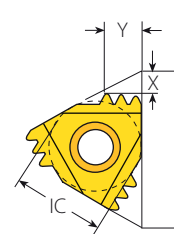

M+ Style

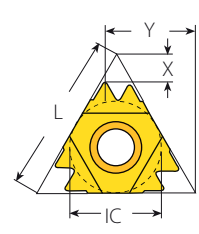

Z+ Style

## Standard



SCB



V6

Insert Size		Pitch	Ordering Code		Dimensions inch			Anvil		Toolholder
IC	L inch	tpi	RH	LH	h min	X	Y	RH	LH	
1/4"	0.43	27	2IR27NPT...	2IL27NPT...	0.026	0.03	0.03	-	-	NVR..-2 (LH)
		18	2IR18NPT...	2IL18NPT...	0.040	0.03	0.04			
		14	2IR14NPT...	2IL14NPT...	0.052	0.03	0.04			
1/4" SCB	0.43	27	2JIR27NPT...		0.026	0.02	0.03	-	-	NVR..-2
		18	2JIR18NPT...		0.040	0.02	0.03			
3/8"	0.63	27	3IR27NPT...	3IL27NPT...	0.026	0.03	0.03	YI3	YE3	AVR..-3 (LH)
		18	3IR18NPT...	3IL18NPT...	0.040	0.03	0.04			
		14	3IR14NPT...	3IL14NPT...	0.052	0.04	0.05			
		11.5	3IR11.5NPT...	3IL11.5NPT...	0.065	0.04	0.06			
3/8" SCB	0.63	27	3JIR27NPT...		0.026	0.02	0.03	YI3	-	AVR..-3
		18	3JIR18NPT...		0.040	0.02	0.03			
		14	3JIR14NPT...		0.052	0.04	0.06			
		11.5	3JIR11.5NPT...		0.065	0.04	0.06			
3/8" V6	0.63	14	3IR14NPT-6C...		0.052	0.07	0.11	YI3-6C	-	AVR..-3 NVRC..-3V6

## M+ Style



Insert Size		Pitch	Teeth	Ordering Code	Dimensions inch			Anvil		Toolholder
IC	L inch	tpi		RH	h min	X	Y	RH		
3/8"	0.63	14	2	3IR14NPT2M+...	0.052	0.08	0.12	YI3M		AVR..-3
1/2"	0.87	11.5	2	4IR11.5NPT2M+...	0.065	0.09	0.13	YI4M		AVR..-4
		8	2	5IR8NPT2M+...	0.095	0.12	0.19	YI5M		AVR..-5M

## Z+ Style



Insert Size		Pitch	Teeth	Ordering Code	Dimensions inch			Anvil		Toolholder
IC	L inch	tpi		RH	h min	X	Y	RH		
1/2"	0.87	11.5	2	4IR11.5NPT2Z+...	0.065	0.11	0.39	YI4Z		AVR..-4Z
		8	2	4IR8NPT2Z+...	0.095	0.13	0.38			

# NPT (con't)



## Internal

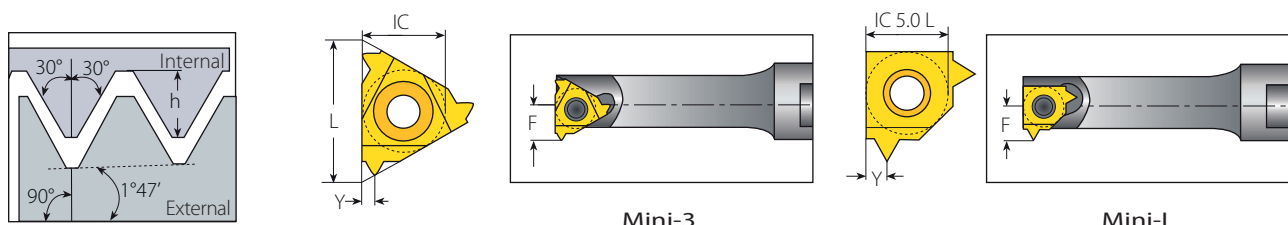

Defined by: USAS B2.1:1968  
Tolerance class: Standard NPT

## Mini-3



Insert Size		Pitch	Ordering Code	Dimensions inch			Min. Bore dia.	Toolholder
IC	L inch	tpi	RH	h min	Y	F	inch	
4.0	0.24	27	4.0KIR27NPT...	0.026	0.02	0.15	0.25	.NVR.020-4.0K
		27	6.0IR27NPT...	0.026	0.03	0.21		
6.0	0.39	18	6.0IR18NPT...	0.040	0.04	0.21	0.39	.NVR.-6.0
		14	6.0IR14NPT...	0.052	0.04	0.21		

## Mini-L



Insert Size		Pitch	Ordering Code	Dimensions inch			Min. Bore dia.	Toolholder
IC mm		tpi	RH	h min	Y	F	inch	
5.0L		27	5LIR27NPT...	0.026	0.03	0.18	0.31	.NVR...-5L
		18	5LIR18NPT...	0.040	0.04	0.18		
		14	5LIR14NPT...	0.052	0.04	0.18		

# NPT

## Internal

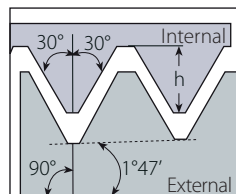

Defined by: USAS B2.1:1968  
Tolerance class: Standard NPT

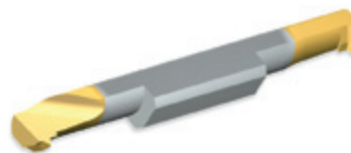
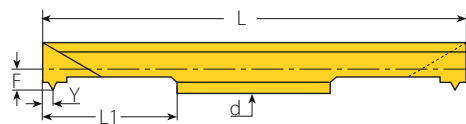

RH-Double Ended

## Micro - Double Ended

Thread	Insert dia.		Ordering Code	Dimensions inch						Min. Bore dia.	Toolholder
	d mm	mm		RH/LH	L1	L	F	Y	h min		
1/16"-27NPT	6.0	27	6.0SIR27NPT...	0.63	1.97	0.10	0.04	0.026	0.23	SMC..-6.0	
1/4"-18NPT		18	6.0SIR18NPT...	0.63	1.97	0.10	0.03	0.040	0.24		

Left Handed Tool Supplied by Request. (Example: 6.0SIL18NPT...)



# NPTF

## External

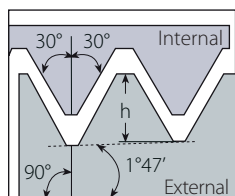

Defined by: ANSI B1.20.3-1976  
 Tolerance class: Class 2

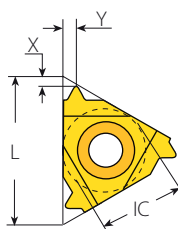

Standard

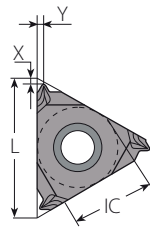

SCB  
 Sintered  
 Chipbreaker

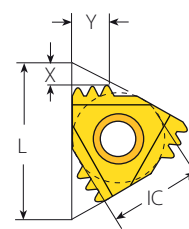

M+ Style

## Standard

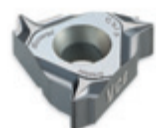

SCB

Insert Size		Pitch	Ordering Code		Dimensions inch			Anvil		Toolholder
IC	L inch	tpi	RH	LH	h min	X	Y	RH	LH	
1/4"	0.43	27	2ER27NPTF...	2EL27NPTF...	0.025	0.03	0.03	-	-	NL..-2 (LH)
		18	2ER18NPTF...	2EL18NPTF...	0.039	0.03	0.04			
		14	2ER14NPTF...	2EL14NPTF...	0.053	0.03	0.04			
3/8"	0.63	27	3ER27NPTF...	3EL27NPTF...	0.025	0.03	0.03	YE3	YI3	AL..-3 (LH)
		18	3ER18NPTF...	3EL18NPTF...	0.039	0.03	0.04			
		14	3ER14NPTF...	3EL14NPTF...	0.053	0.04	0.05			
		11.5	3ER11.5NPTF...	3EL11.5NPTF...	0.064	0.04	0.06			
3/8" SCB	0.63	8	3ER8NPTF...	3EL8NPTF...	0.094	0.05	0.07	YE3	-	AL..-3
		27	3JER27NPTF...		0.025	0.03	0.03			
		18	3JER18NPTF...		0.039	0.02	0.03			
		14	3JER14NPTF...		0.053	0.04	0.06			
		11.5	3JER11.5NPTF...		0.064	0.04	0.06			
		8	3JER8NPTF		0.094	0.04	0.06			

## M+ Style



**Multi**plus

Insert Size		Pitch	Teeth	Ordering Code	Dimensions inch			Anvil		Toolholder
IC	L inch	tpi		RH	h min	X	Y	RH		
3/8"	0.63	14	2	3ER14NPTF2M+...	0.053	0.08	0.12	YE3M	AL...-3	

# NPTF (con't)

## Internal

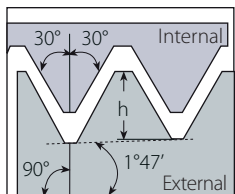

Defined by: ANSI B1.20.3-1976  
Tolerance class: Class 2

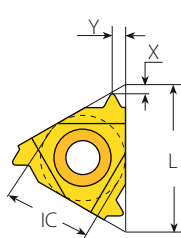

Standard

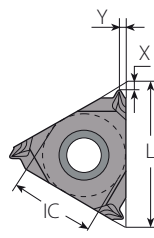

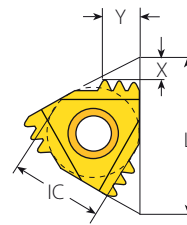

SCB  
Sintered  
Chipbreaker

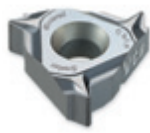

M+ Style

## Standard

Insert Size		Pitch	Ordering Code		Dimensions inch			Anvil		Toolholder	
IC	L inch	tpi	RH	LH	h min	X	Y	RH	LH		
	1/4"	0.43	27	2IR27NPTF...	2IL27NPTF...	0.025	0.03	0.03	-	-	NVR..-2 (LH)
			18	2IR18NPTF...	2IL18NPTF...	0.039	0.03	0.04	-	-	
			14	2IR14NPTF...	2IL14NPTF...	0.053	0.03	0.04	-	-	
	1/4" SCB	0.43	27	2JR27NPTF...		0.025	0.03	0.03	-	-	NVR..-2
			18	2JR18NPTF...		0.039	0.02	0.03	-	-	
	3/8"	0.63	27	3IR27NPTF...	3IL27NPTF...	0.025	0.03	0.03	Y13	YE3	AVR..-3 (LH)
			18	3IR18NPTF...	3IL18NPTF...	0.039	0.03	0.04			
			14	3IR14NPTF...	3IL14NPTF...	0.053	0.04	0.05			
			11.5	3IR11.5NPTF...	3IL11.5NPTF...	0.064	0.04	0.06			
			8	3IR8NPTF...	3IL8NPTF...	0.094	0.05	0.07			
	3/8" SCB	0.63	27	3JR27NPTF...		0.025	0.03	0.03	Y13	-	AVR..-3
			18	3JR18NPTF...		0.039	0.02	0.03			
			14	3JR14NPTF...		0.053	0.04	0.06			
			11.5	3JR11.5NPTF...		0.064	0.04	0.06			
			8	3JR8NPTF...		0.094	0.04	0.06			

## M+ Style



Insert Size		Pitch	Teeth	Ordering Code	Dimensions inch			Anvil	Toolholder
IC	L inch	tpi		RH	h min	X	Y	RH	
3/8"	0.63	14	2	3IR14NPTF2M+...	0.053	0.08	0.12	Y13M	AVR..-3

## NPTF (con't)



### Internal

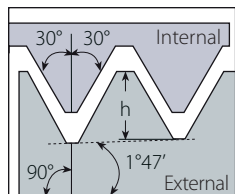

Defined by: ANSI B1.20.3-1976  
Tolerance class: Class 2

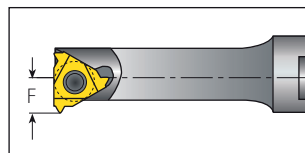
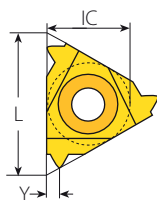

Mini-3

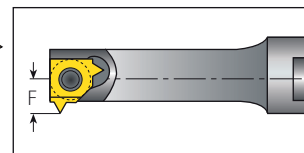
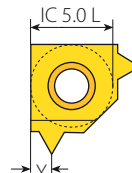

Mini-L

### Mini-3



Insert Size		Pitch	Ordering Code	Dimensions inch			Min. Bore dia.	Toolholder
IC	L inch	tpi	RH	h min	Y	F	inch	
4.0	0.24	27	4.0KIR27NPTF...	0.025	0.02	0.14	0.25	.NVR.020-4.0K
		27	6.0IR27NPTF...	0.025	0.03	0.21		
6.0	0.39	18	6.0IR18NPTF...	0.039	0.04	0.21	0.39	.NVR...-6.0
		14	6.0IR14NPTF...	0.053	0.04	0.21		

### Mini-L



Insert Size		Pitch	Ordering Code	Dimensions inch			Min. Bore dia.	Toolholder
IC mm		tpi	RH	h min	Y	F	inch	
5.0L		27	5LIR27NPTF...	0.025	0.03	0.18	0.31	.NVR...-5L
		18	5LIR18NPTF...	0.039	0.04	0.18		
		14	5LIR14NPTF...	0.053	0.04	0.18		

## NPTF

### Internal

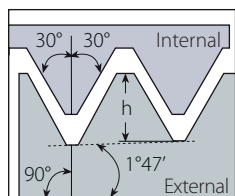

Defined by: ANSI B1.20.3-1976  
Tolerance class: Class 2

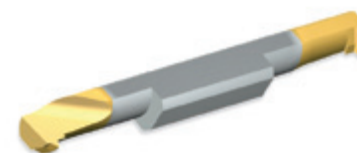
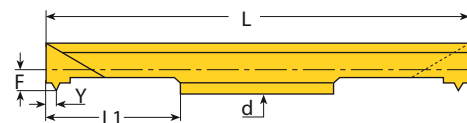

RH-Double Ended

### Micro - Double Ended

Thread	Insert dia. d mm	Pitch tpi	Ordering Code RH/LH	L1	L	F	Y	h min	Min. Bore dia. inch	Toolholder
1/16"-27NPTF	6.0	27	6.0SIR27NPTF...	0.63	1.97	0.10	0.03	0.025	0.24	SMC...-6.0
1/4"-18NPTF		18	6.0SIR18NPTF...	0.63	1.97	0.10	0.04	0.039		

Left Handed Tool Supplied by Request. (Example: 6.0SIL18NPTF...)

# NPS

## External / Internal

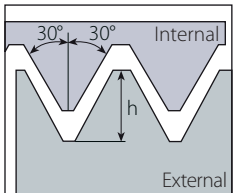

Defined by: USA NBS H28 (1957)  
Tolerance class: Standard NPS

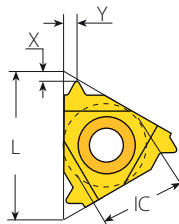

External - Standard

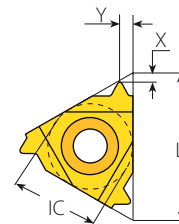

Internal - Standard

## External

### Standard



Insert Size		Pitch	Ordering Code		Dimensions inch			Anvil		Toolholder
IC	L inch	tpi	RH	LH	h min	X	Y	RH	LH	
3/8"	0.63	24	3ER24NPS...	3EL24NPS...	0.031	0.03	0.03	YE3	YI3	AL...-3 (LH)
		16	3ER16NPS...	3EL16NPS...	0.048	0.03	0.04			
		14	3ER14NPS...	3EL14NPS...	0.052	0.04	0.05			
		12	3ER12NPS...	3EL12NPS...	0.064	0.04	0.06			
		11.5	3ER11.5NPS...	3EL11.5NPS...	0.067	0.04	0.06			
1/2"	0.87	9	3ER9NPS...	3EL9NPS...	0.087	0.05	0.06	YE4	YI4	AL...-4 (LH)
		8	4ER8NPS...	4EL8NPS...	0.097	0.05	0.07			
		7	4ER7NPS...	4EL7NPS...	0.111	0.06	0.09			
5/8"	1.06	6	4ER6NPS...	4EL6NPS...	0.130	0.06	0.09	YE5	YI5	AL...-5 (LH)
		5	5ER5NPS...	5EL5NPS...	0.157	0.07	0.11			

## Internal

### Standard



Insert Size		Pitch	Ordering Code		Dimensions inch			Anvil		Toolholder
IC	L inch	tpi	RH	LH	h min	X	Y	RH	LH	
3/8"	0.63	24	3IR24NPS...	3IL24NPS...	0.031	0.03	0.03	YI3	YE3	AVR...-3 (LH)
		14	3IR14NPS...	3IL14NPS...	0.052	0.04	0.05			
		12	3IR12NPS...	3IL12NPS...	0.064	0.04	0.06			
		11.5	3IR11.5NPS...	3IL11.5NPS...	0.067	0.04	0.06			
1/2"	0.87	9	3IR9NPS...	3IL9NPS...	0.087	0.05	0.06	YI4	YE4	AVR...-4 (LH)
		8	4IR8NPS...	4IL8NPS...	0.097	0.05	0.07			
		7	4IR7NPS...	4IL7NPS...	0.111	0.06	0.09			
5/8"	1.06	6	4IR6NPS...	4IL6NPS...	0.130	0.06	0.09	YI5	YE5	AVR...-5 (LH)
		5	5IR5NPS...	5IL5NPS...	0.157	0.07	0.11			

## Round (DIN 405)

### External

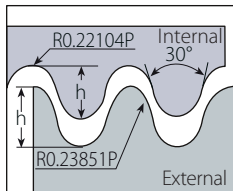

Defined by: DIN 405  
 Tolerance class: 7h/7H

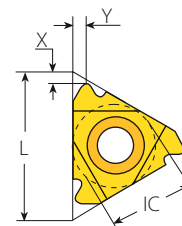

Standard

### Standard



Insert Size		Pitch	Ordering Code		Dimensions inch			Anvil		Toolholder
IC	L inch	tpi	RH	LH	h min	X	Y	RH	LH	
3/8"	0.63	10	3ER10RD...	3EL10RD...	0.050	0.04	0.05	YE3	YI3	AL..-3 (LH)
		8	3ER8RD...	3EL8RD...	0.063	0.06	0.05			
		6	3ER6RD...	3EL6RD...	0.083	0.06	0.07			
1/2"	0.87	6	4ER6RD...	4EL6RD...	0.083	0.06	0.07	YE4	YI4	AL..-4 (LH)
		4	4ER4RD...	4EL4RD...	0.125	0.09	0.09			
5/8"	1.06	4	5ER4RD...	5EL4RD...	0.125	0.09	0.09	YE5	YI5	AL..-5 (LH)

### Internal

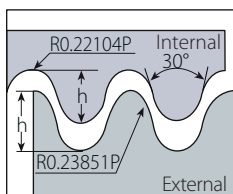

Defined by: DIN 405  
 Tolerance class: 7h/7H

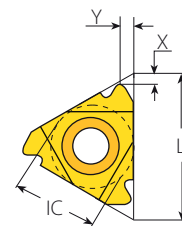

Standard

### Standard



Insert Size		Pitch	Ordering Code		Dimensions inch			Anvil		Toolholder
IC	L inch	tpi	RH	LH	h min	X	Y	RH	LH	
3/8"	0.63	10	3IR10RD...	3IL10RD...	0.050	0.04	0.05	YI3	YE3	AVR..-3 (LH)
		8	3IR8RD...	3IL8RD...	0.063	0.06	0.06			
		6	3IR6RD...	3IL6RD...	0.083	0.06	0.06			
1/2"	0.87	6	4IR6RD...	4IL6RD...	0.083	0.06	0.07	YI4	YE4	AVR..-4 (LH)
		4	4IR4RD...	4IL4RD...	0.125	0.09	0.09			
5/8"	1.06	4	5IR4RD...	5IL4RD...	0.125	0.09	0.09	YI5	YE5	AVR..-5 (LH)

## Round (DIN 20400)

### External

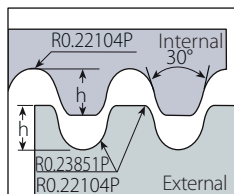

Defined by: DIN 20400  
Tolerance class: Standard

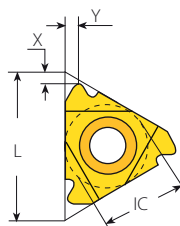

Standard

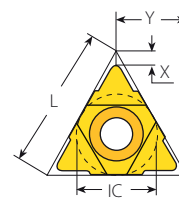

U Style

### Standard



Insert Size		Pitch	Ordering Code		Dimensions inch			Anvil		Toolholder
IC	L inch	mm	RH	LH	h min	X	Y	RH	LH	
1/2"	0.87	3.0	4ER3.ORD20400...	4EL3.ORD20400...	0.065	0.05	0.07	YE4	YI4	AL...-4 (LH)
		4.0	4ER4.ORD20400...	4EL4.ORD20400...	0.087	0.06	0.09			
		5.0	4ER5.ORD20400...	4EL5.ORD20400...	0.108	0.06	0.07			
		6.0	4ER6.ORD20400...	4EL6.ORD20400...	0.13	0.07	0.08			

### U Style



Insert Size		Pitch	Ordering Code		Dimensions inch			Anvil		Toolholder
IC	L inch	mm	RH+LH	h min	X	Y	RH	LH		
5/8"U	1.06	8.0	5UEI8.ORD20400...		0.173	0.11	0.53	YE5U	YI5U	AL...-5U (LH)

## Round (DIN 20400)

### Internal

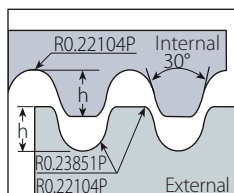

Defined by: DIN 20400  
Tolerance class: Standard

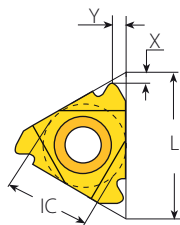

Standard

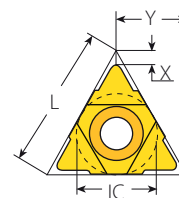

U Style

### Standard



Insert Size		Pitch	Ordering Code		Dimensions inch			Anvil		Toolholder
IC	L inch	mm	RH	LH	h min	X	Y	RH	LH	
1/2"	0.87	3.0	4IR3.ORD20400...	4IL3.ORD20400...	0.065	0.05	0.07	YI4	YE4	AVR...-4 (LH)
		4.0	4IR4.ORD20400...	4IL4.ORD20400...	0.087	0.06	0.09			
		5.0	4IR5.ORD20400...	4IL5.ORD20400...	0.108	0.06	0.07			
		6.0	4IR6.ORD20400...	4IL6.ORD20400...	0.130	0.07	0.08			

### U Style



Insert Size		Pitch	Ordering Code		Dimensions inch			Anvil		Toolholder
IC	L inch	mm	RH+LH	h min	X	Y	RH	LH		
5/8"U	1.06	8.0	5UEI8.ORD20400...		0.173	0.11	0.53	YI5U	YE5U	AVR...-5U (LH)

# Trapez

## External

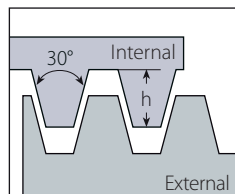

Defined by: DIN 103  
 Tolerance class: 7e/7H

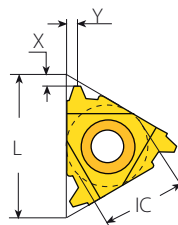

Standard

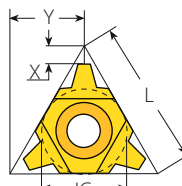

U Style

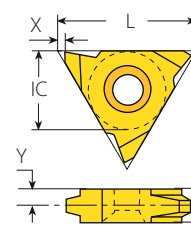

V Style

## Standard



Insert Size		Pitch	Ordering Code		Dimensions inch			Anvil		Toolholder
IC	L inch	mm	RH	LH	h min	X	Y	RH	LH	
1/4"	0.43	1.5	2ER1.5TR...	2EL1.5TR...	0.035	0.03	0.04	-	-	NL..-2 (LH)
		1.5	3ER1.5TR...	3EL1.5TR...	0.035	0.04	0.04			
3/8"	0.63	2.0	3ER2.0TR...	3EL2.0TR...	0.049	0.04	0.05	YE3	YI3	AL..-3 (LH)
		2.5	3ER2.5TR...	3EL2.5TR...	0.061	0.05	0.06			
		3.0	3ER3.0TR...	3EL3.0TR...	0.069	0.05	0.06			
1/2"	0.87	4.0	4ER4.0TR...	4EL4.0TR...	0.089	0.07	0.07	YE4	YI4	AL..-4 (LH)
		5.0	4ER5.0TR...	4EL5.0TR...	0.108	0.08	0.10			
		6.0	4ER6.0TR...	4EL6.0TR...	0.138	0.09	0.11			
5/8"	1.06	6.0	5ER6.0TR...	5EL6.0TR...	0.138	0.09	0.11	YE5	YI5	AL..-5 (LH)

## U Style



Insert Size		Pitch	Ordering Code		Dimensions inch			Anvil		Toolholder
IC	L inch	mm	RH+LH		h min	X	Y	RH	LH	
1/2"U	0.87	6.0	4UE6.0TR...		0.138	0.08	0.43	YE4U	YI4U	AL..-4U (LH)
		7.0	4UE7.0TR...		0.157	0.09	0.43			
		8.0	4UE8.0TR...		0.177	0.10	0.43			
5/8"U	1.06	8.0	5UE8.0TR...		0.177	0.10	0.54	YE5U	YI5U	AL..-5U (LH)
		9.0	5UE9.0TR...		0.197	0.12	0.54			

## V Style



Insert Size		Pitch	Ordering Code		Dimensions inch				Toolholder
IC	L inch	mm	RH	LH	h min	X	Y	T	
5/8"V	1.06	6.0	5VER6.0TR...	5VEL6.0TR...	0.138	0.04	0.13	0.24	NL..-5V-6 (LH)
		7.0	5VER7.0TR...	5VEL7.0TR...	0.157	0.04	0.13	0.24	
		8.0	5VER8.0TR...	5VEL8.0TR...	0.177	0.04	0.13	0.24	NL..-5V-8 (LH)
		9.0	5VER9.0TR...	5VEL9.0TR...	0.197	0.04	0.17	0.31	
		10.0	5VER10.0TR...	5VEL10.0TR...	0.217	0.04	0.17	0.31	
		12.0	5VER12.0TR...	5VEL12.0TR...	0.256	0.04	0.20	0.39	

# Trapez (con't)

## Internal

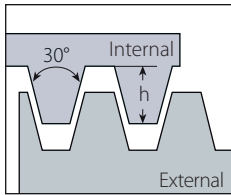

Defined by: DIN 103  
Tolerance class: 7e/7H

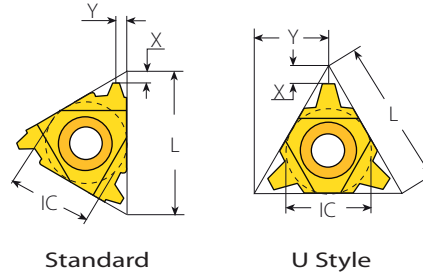

## Standard

Insert Size		Pitch	Ordering Code		Dimensions inch			Anvil		Toolholder
IC	L inch	mm	RH	LH	h min	X	Y	RH	LH	
1/4"	0.43	1.5	2IR1.5TR...	2IL1.5TR...	0.035	0.03	0.04	-	-	NVR 8-2 (LH)
		1.5	3IR1.5TR...	3IL1.5TR...	0.035	0.04	0.04			
3/8"	0.63	2.0	3IR2.0TR...	3IL2.0TR...	0.049	0.04	0.05	YI3	YE3	AVR.-3 (LH)
		2.5	3IR2.5TR...	3IL2.5TR...	0.060	0.05	0.06			
		3.0	3IR3.0TR...	3IL3.0TR...	0.069	0.05	0.06			
1/2"	0.87	4.0	4IR4.0TR...	4IL4.0TR...	0.089	0.07	0.07	YI4	YE4	AVR.-4 (LH)
		5.0	4IR5.0TR...	4IL5.0TR...	0.108	0.08	0.10			
		6.0	4IR6.0TR...	4IL6.0TR...	0.138	0.09	0.11			
5/8"	1.06	6.0	5IR6.0TR...	5IL6.0TR...	0.138	0.09	0.11	YI5	YE5	AVR.-5 (LH)



## Coarse Pitch

Thread	Insert Size		Ordering Code	Dimensions inch			Toolholder		Min. Bore dia.
	IC	L inch		h min	X	Y			inch
TR18x4	3/8"U	0.63	3UIR4.0TR...158/013	0.089	0.08	0.31	NVRC044-3U	157/020	0.55
TR20x4	3/8"	0.63	3IR4.0TR...158/012	0.089	0.06	0.07	NVRC050-3	157/006	0.63
TR22x5	3/8"U	0.63	3UIR5.0TR...158/011	0.108	0.06	0.31	NVRC055-3U	157/018	0.67
TR24x5			3UIR5.0TR...158/011	0.108	0.06	0.31	NVRC059-3U	157/019	0.75
TR26x5			3UIR5.0TR...158/011	0.108	0.06	0.31	NVRC059-3U	157/019	0.83
TR28x5	1/2"	0.87	4IR5.0TR...	0.108	0.09	0.11	NVRC075-4	157/008	0.91
TR30x6	1/2"U	0.87	4UIR6.0TR...158/007	0.138	0.08	0.43	NVRC075-4U	157/011	0.94
TR36x6	5/8"	1.06	5IR6.0TR...	0.138	0.09	0.11	NVRC100-5	157/012	1.18
TR38x7	1/2"U	0.87	4UIR7.0TR...158/008	0.157	0.09	0.43	NVRC100-4U	157/013	1.22
TR40x7			4UIR7.0TR...158/008	0.157	0.09	0.43	NVRC100-4U	157/013	1.30
TR42x7			4UIR7.0TR...158/008	0.157	0.09	0.43	NVRC125-4U	157/014	1.38
TR44x7			4UIR7.0TR...158/008	0.157	0.09	0.43	NVRC125-4U	157/014	1.46
TR46x8	5/8"U	1.06	5UIR8.0TR...158/010	0.177	0.10	0.53	NVRC125-5U	157/015	1.50
TR48x8			5UIR8.0TR...158/010	0.177	0.10	0.53	NVRC125-5U	157/015	1.57
TR50x8			5UIR8.0TR...158/010	0.177	0.10	0.53	NVRC125-5U	157/015	1.65
TR52x8			5UIR8.0TR...158/010	0.177	0.10	0.53	NVRC125-5U	157/015	1.73



Left Handed Tool Supplied by Request.

U Type Inserts Can be Used for LH Applications with LH toolholders.



# Trapez (con't)

## Internal

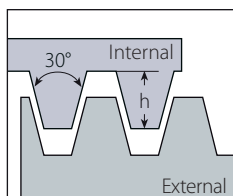

Defined by: DIN 103  
Tolerance class: 7e/7H

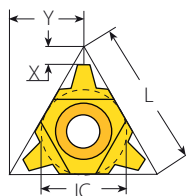

U Style

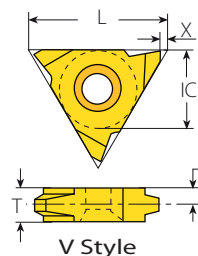

V Style

## U Style



Insert Size		Pitch	Ordering Code	Dimensions inch			Anvil		Toolholder
IC	L inch	mm	RH+LH	h min	X	Y	RH	LH	
1/2"U	0.87	6.0	4UI6.0TR...	0.138	0.08	0.43	Y14U	YE4U	AVR...-4U (LH)
		7.0	4UI7.0TR...	0.157	0.09	0.43			
		8.0	4UI8.0TR...	0.177	0.10	0.43			
5/8"U	1.06	8.0	5UI8.0TR...	0.177	0.10	0.54	Y15U	YE5U	AVR...-5U (LH)
		9.0	5UI9.0TR...	0.197	0.12	0.54			

## V Style



Insert Size		Pitch	Ordering Code		Dimensions inch				Toolholder
IC	L inch	mm	RH	LH	h min	X	Y	T	
5/8"V	1.06	6.0	5VIR6.0TR...	5VIL6.0TR...	0.138	0.04	0.13	0.24	NVR...-5V (LH)
		7.0	5VIR7.0TR...	5VIL7.0TR...	0.157	0.04	0.13	0.24	
		8.0	5VIR8.0TR...	5VIL8.0TR...	0.177	0.04	0.13	0.24	
		9.0	5VIR9.0TR...	5VIL9.0TR...	0.197	0.04	0.17	0.31	
		10.0	5VIR10.0TR...	5VIL10.0TR...	0.217	0.04	0.17	0.31	
		12.0	5VIR12.0TR...	5VIL12.0TR...	0.256	0.04	0.20	0.39	



## Internal

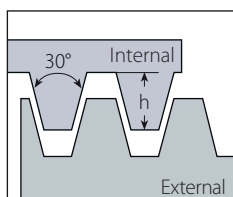

Defined by: DIN 103  
Tolerance class: 7e/7H

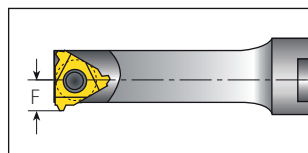
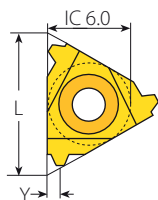

Mini-3

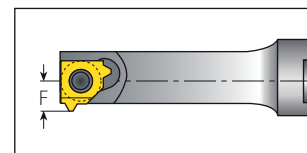
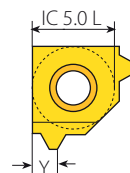

Mini-L

## Mini-3



Insert Size		Pitch	Ordering Code	Dimensions inch			Min. Bore dia.	Toolholder
IC	L inch	mm	RH	h min	Y	F	inch	
6.0	0.39	1.5	6.0IR1.5TR...	0.033	0.03	0.21	0.39	.NVR...-6.0
		2.0	6.0IR2.0TR...	0.049	0.05	0.21	0.39	

## Mini-L



Insert Size		Pitch	Ordering Code	Dimensions inch			Min. Bore dia.	Toolholder
IC mm	mm	mm	RH	h min	Y	F	inch	
5.0L		1.5	5LIR1.5TR...	0.033	0.03	0.18	0.31	.NVR...-5L
		2.0	5LIR2.0TR...	0.049	0.05	0.18	0.31	

Left Handed Tool Supplied by Request. (Example: 6.0IL2.0TR...)

# American ACME

## External

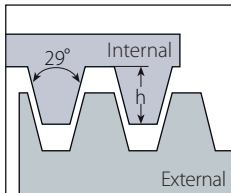

Defined by: ANSI B1.5:1988  
Tolerance class: 3G

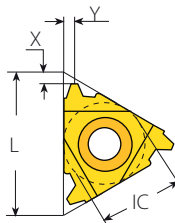

Standard

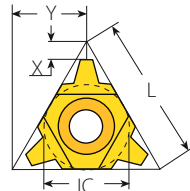

U Style

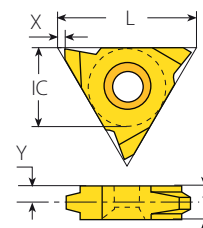

V Style

## Standard



Insert Size		Pitch	Ordering Code		Dimensions inch			Anvil		Toolholder
IC	L inch	tpi	RH	LH	h min	X	Y	RH	LH	
1/4"	0.43	16	2ER16ACME...	2EL16ACME...	0.036	0.04	0.04	-	-	NL...-2 (LH)
		16	3ER16ACME...	3EL16ACME...	0.036	0.04	0.04			
		14	3ER14ACME...	3EL14ACME...	0.041	0.04	0.05			
		12	3ER12ACME...	3EL12ACME...	0.047	0.04	0.05			
		10	3ER10ACME...	3EL10ACME...	0.060	0.05	0.06	YE3	YI3	AL...-3 (LH)
		8	3ER8ACME...	3EL8ACME...	0.072	0.06	0.06			
3/8"	0.63	7	3ER7ACME...	3EL7ACME...	0.082	0.07	0.09			
		6	3ER6ACME...	3EL6ACME...	0.093	0.07	0.07	YE3AC6	YI3AC6	
		7	4ER7ACME...	4EL7ACME...	0.082	0.07	0.09			
1/2"	0.87	6	4ER6ACME...	4EL6ACME...	0.093	0.07	0.08	YE4	YI4	AL...-4 (LH)
		5	4ER5ACME...	4EL5ACME...	0.110	0.08	0.09			
5/8"	1.06	4	5ER4ACME...	5EL4ACME...	0.135	0.09	0.11	YE5	YI5	AL...-5 (LH)

## U Style



Insert Size		Pitch	Ordering Code		Dimensions inch			Anvil		Toolholder
IC	L inch	tpi	RH+LH		h min	X	Y	RH	LH	
1/2"U	0.87	3	4UE3ACME...		0.177	0.12	0.43	YE4U	YI4U	AL...-4U (LH)
		4	4UE4ACME...		0.135	0.09	0.43			
5/8"U	1.06	3	5UE3ACME...		0.177	0.12	0.54	YE5U	YI5U	AL...-5U (LH)

## V Style



Insert Size		Pitch	Ordering Code		Dimensions inch				Toolholder
IC	L inch	tpi	RH	LH	h min	X	Y	T	
5/8"V	1.06	4	5VER4ACME...	5VEL4ACME...	0.135	0.04	0.13	0.24	
		3.5	5VER3.5ACME...	5VEL3.5ACME...	0.152	0.04	0.13	0.24	NL...-5V-6 (LH)
		3	5VER3ACME...	5VEL3ACME...	0.177	0.04	0.13	0.24	
		2	5VER2ACME...	5VEL2ACME...	0.26	0.04	0.20	0.39	NL...-5V-10 (LH)

## American ACME (con't)

### Internal

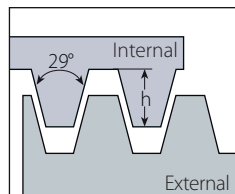

Defined by: ANSI B1.5:1988  
 Tolerance class: 3G

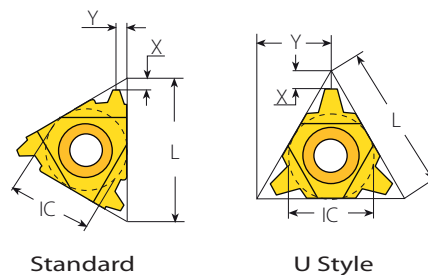

### Standard



Insert Size		Pitch	Ordering Code		Dimensions inch			Anvil		Toolholder
IC	L inch	tpi	RH	LH	h min	X	Y	RH	LH	
1/4"	0.43	16	2IR16ACME...	2IL16ACME...	0.036	0.04	0.04	-	-	NVR..-2 (LH)
		16	3IR16ACME...	3IL16ACME...	0.036	0.04	0.04			
		14	3IR14ACME...	3IL14ACME...	0.041	0.04	0.05			
		12	3IR12ACME...	3IL12ACME...	0.047	0.05	0.05	YI3	YE3	AVR..-3 (LH)
		10	3IR10ACME...	3IL10ACME...	0.060	0.05	0.05			
3/8"	0.63	8	3IR8ACME...	3IL8ACME...	0.072	0.06	0.06			
		6	3IR6ACME...	3IL6ACME...	0.093	0.07	0.07	YI3AC6	YE3AC6	
		6	4IR6ACME...	4IL6ACME...	0.093	0.07	0.08	YI4	YE4	AVR..-4 (LH)
1/2"	0.87	5	4IR5ACME...	4IL5ACME...	0.110	0.08	0.09			
		4	5IR4ACME...	5IL4ACME...	0.135	0.09	0.10	YI5	YE5	AVR..-5 (LH)

### Coarse Pitch



Thread	Insert Size		Ordering Code	Dimensions inch			Anvil	Min. Bore dia.	
tpi	IC	L inch	RH	h min	X	Y	RH	Toolholder	inch
1/2"x10	6.0U	10	6.0UIR10ACME...158/005	0.060	0.04	0.20	-	NVRC 032-6.0U 157/003	0.40
5/8"x8	1/4"U	11	2UIR8ACME...158/006	0.072	0.04	0.22	-	NVRC 039-2U 157/004	0.50
3/4"x6	3/8"	16	3IR6ACME...	0.093	0.07	0.07	-	NVRC 044-3 157/005	0.58
7/8"x6			3IR6ACME...	0.093	0.07	0.07	-	NVRC 050-3 157/006	0.73
1"x5	1/2"	22	4IR5ACME...	0.110	0.08	0.09	-	NVRC 067-4 157/007	0.80
1 1/8"x5			4IR5ACME...	0.110	0.08	0.09	-	NVRC 075-4 157/008	0.94
1 1/4"x5			4IR5ACME...	0.110	0.08	0.09	-	NVRC 075-4 157/009	1.07
1 1/2"x4	5/8"	27	5IR4ACME...	0.135	0.09	0.10	-	NVRC 110-5 157/010	1.27
1 3/4"x4			5IR4ACME...	0.135	0.09	0.10	YI5-1P	AVRC 125-5	1.53

Left Handed Tool Supplied by Request.

### U Style



Insert Size		Pitch	Ordering Code	Dimensions inch			Anvil		Toolholder
IC	L inch	tpi	RH+LH	h min	X	Y	RH	LH	
1/2"U	0.87	4	4UI4ACME...	0.135	0.09	0.43	YI4U	YE4U	AVR..-4U (LH)
		3	4UI3ACME...	0.177	0.11	0.43			
5/8"U	1.06	3	5UI3ACME...	0.177	0.11	0.54	YI5U	YE5U	AVR..-5U(LH)

# American ACME (con't)

## Internal

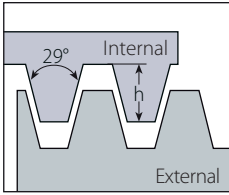

Defined by: ANSI B1.5:1988  
Tolerance class: 3G

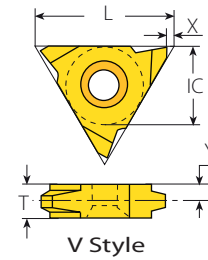

## V Style



Insert Size		Pitch	Ordering Code		Dimensions inch			Toolholder	
IC	L inch	tpi	RH	LH	h min	X	Y		T
5/8"V	1.06	4	5VIR4ACME...	5VIL4ACME...	0.135	0.04	0.13	0.24	NVR...-5V (LH)
		3.5	5VIR3.5ACME...	5VIL3.5ACME...	0.152	0.04	0.13	0.24	
		3	5VIR3ACME...	5VIL3ACME...	0.177	0.04	0.13	0.24	
		2	5VIR2ACME...	5VIL2ACME...	0.260	0.04	0.20	0.39	



## Internal

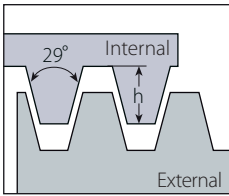

Defined by: ANSI B1.5:1988  
Tolerance class: 3G

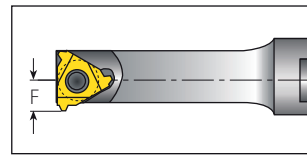
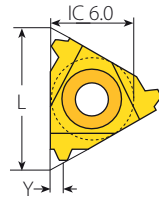

Mini-3

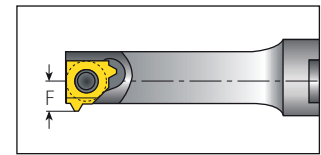
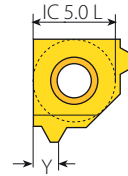

Mini-L

## Mini-3



Insert Size		Pitch	Ordering Code		Dimensions inch			Min. Bore dia.	Toolholder
IC	L inch	tpi	RH	LH	h min	Y	F	inch	
6.0	0.39	12	6.0IR12ACME...		0.047	0.04	0.20	0.39	.NVR...-6.0

## Mini-L



Insert Size		Pitch	Ordering Code		Dimensions inch			Min. Bore dia.	Toolholder
IC mm		tpi	RH	LH	h min	Y	F	inch	
5.0L		12	5LIR12ACME...		0.047	0.04	0.17	0.31	.NVR...-5L

Left Handed Tool Supplied by Request. (Example: 6.0L12ACME...)

# Stub ACME

## External

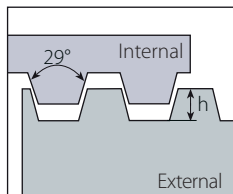

Defined by: ANSI B1.8:1988  
 Tolerance class: 2G

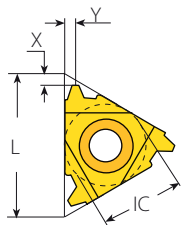

Standard

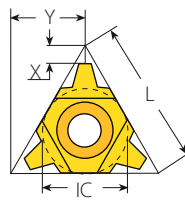

U Style

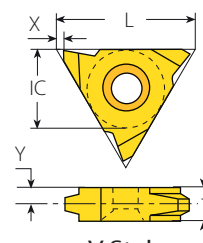

V Style

## Standard



Insert Size		Pitch	Ordering Code		Dimensions inch			Anvil		Toolholder
IC	L inch	tpi	RH	LH	h min	X	Y	RH	LH	
1/4"	0.43	16	2ER16STACME...	2EL16STACME...	0.024	0.04	0.04	-	-	NL..-2 (LH)
		16	3ER16STACME...	3EL16STACME...	0.024	0.04	0.04			
		14	3ER14STACME...	3EL14STACME...	0.026	0.04	0.04			
		12	3ER12STACME...	3EL12STACME...	0.030	0.05	0.05	YE3	YI3	AL..-3 (LH)
		10	3ER10STACME...	3EL10STACME...	0.040	0.05	0.05			
		8	3ER8STACME...	3EL8STACME...	0.048	0.06	0.06			
1/2"	0.87	6	4ER6STACME...	4EL6STACME...	0.060	0.07	0.07			
		5	4ER5STACME...	4EL5STACME...	0.070	0.08	0.09	YE4	YI4	AL..-4 (LH)
		4	4ER4STACME...	4EL4STACME...	0.085	0.09	0.09			
5/8"	1.06	4	5ER4STACME...	5EL4STACME...	0.085	0.09	0.09	YE5	YI5	AL..-5 (LH)
		3	5ER3STACME...	5EL3STACME...	0.110	0.11	0.11			

## U Style



Insert Size		Pitch	Ordering Code	Dimensions inch			Anvil		Toolholder
IC	L inch	tpi	RH+LH	h min	X	Y	RH	LH	
1/2"U	0.87	4	4UE4STACME...	0.085	2.6	11.0	YE4U	YI4U	AL..-4U (LH)
		3	4UE3STACME...	0.110	3.4	11.0			

## V Style



Insert Size		Pitch	Ordering Code		Dimensions inch				Toolholder
IC	L inch	tpi	RH	LH	h min	X	Y	T	
5/8"V	1.06	4	5VER4STACME...	5VEL4STACME...	0.085	0.04	0.13	0.24	NL..-5V-6 (LH)
		3	5VER3STACME...	5VEL3STACME...	0.110	0.04	0.13	0.24	NL..-5V-6 (LH)
		2	5VER2STACME...	5VEL2STACME...	0.160	0.04	0.17	0.31	NL..-5V-8 (LH)

# Stub ACME (con't)

## Internal

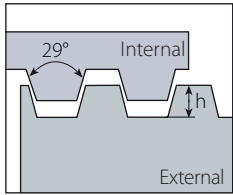

Defined by: ANSI B1.8:1988  
Tolerance class: 2G

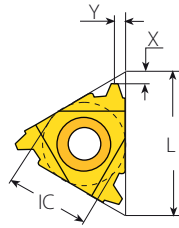

Standard

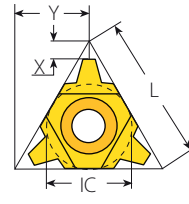

U Style

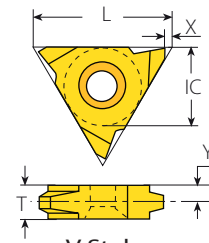

V Style

## Standard



Insert Size		Pitch	Ordering Code		Dimensions inch			Anvil		Toolholder
IC	L inch	tpi	RH	LH	h min	X	Y	RH	LH	
1/4"	0.43	16	2IR16STACME...	2IL16STACME...	0.024	0.04	0.04	-	-	NVR..-2 (LH)
		16	3IR16STACME...	3IL16STACME...	0.024	0.04	0.04			
		14	3IR14STACME...	3IL14STACME...	0.026	0.04	0.04			
		12	3IR12STACME...	3IL12STACME...	0.030	0.04	0.05	Y13	YE3	AVR..-3 (LH)
		10	3IR10STACME...	3IL10STACME...	0.040	0.05	0.05			
		8	3IR8STACME...	3IL8STACME...	0.048	0.06	0.06			
1/2"	0.63	6	3IR6STACME...	3IL6STACME...	0.060	0.07	0.07			
		6	4IR6STACME...	4IL6STACME...	0.060	0.07	0.07	Y14	YE4	AVR..-4 (LH)
		4	4IR4STACME...	4IL4STACME...	0.085	0.09	0.09			
5/8"	1.06	4	5IR4STACME...	5IL4STACME...	0.085	0.09	0.09	Y15	YE5	AVR..-5 (LH)
		3	5IR3STACME...	5IL3STACME...	0.110	0.11	0.11			

## U Style



Insert Size		Pitch	Ordering Code		Dimensions inch			Anvil		Toolholder
IC	L inch	tpi	RH+LH		h min	X	Y	RH	LH	
1/2"U	0.87	4	4UI4STACME...		0.085	0.10	0.43	Y14U	YE4U	AVR..-4U (LH)
		3	4UI3STACME...		0.110	0.13	0.43			

## V Style



Insert Size		Pitch	Ordering Code		Dimensions inch				Toolholder
IC	L inch	tpi	RH	LH	h min	X	Y	T	
5/8"V	1.06	4	5VIR4STACME...	5VIL4STACME...	0.085	0.04	0.13	0.24	
		3	5VIR3STACME...	5VIL3STACME...	0.110	0.04	0.13	0.24	NVR..-5V (LH)
		2	5VIR2STACME...	5VIL2STACME...	0.160	0.04	0.17	0.31	

# Stub ACME (con't)



## Internal

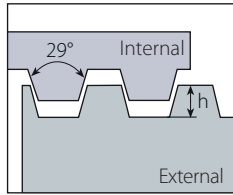

Defined by: ANSI B1.8:1988  
Tolerance class: 2G

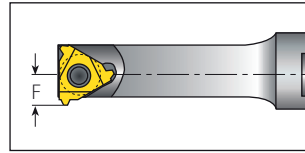
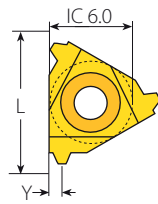

Mini-3

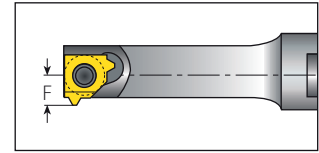
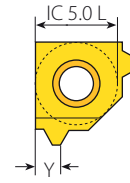

Mini-L

## Mini-3



Insert Size		Pitch	Ordering Code	Dimensions inch			Min. Bore dia.	Toolholder
IC	L inch	tpi	RH	h min	Y	F	inch	
6.0	0.39	12	6.0IR12STACME...	0.03	0.05	0.20	0.39	.NVR..-6.0

## Mini-L



Insert Size		Pitch	Ordering Code	Dimensions inch			Min. Bore dia.	Toolholder
IC mm	tpi		RH	h min	Y	F	inch	
5.0L	12		5LIR12STACME...	0.03	0.05	0.17	0.31	.NVR...-5L

Left Handed Tool Supplied by Request. (Example: 6.0L12STACME...)

# UNJ - UNJC, UNJF, UNJEF, UNJS

## External

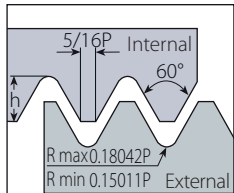

Defined by: MIL-S-8879C  
Tolerance class: 3A/3B

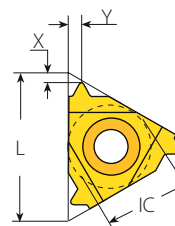

Standard

## Standard



Insert Size		Pitch	Ordering Code		Dimensions inch			Anvil		Toolholder
IC	L inch	tpi	RH	LH	h min	X	Y	RH	LH	
1/4"	0.43	48	2ER48UNJ...	2EL48UNJ...	0.012	0.02	0.02	-	-	NL..-2 (LH)
		44	2ER44UNJ...	2EL44UNJ...	0.013	0.02	0.02			
		40	2ER40UNJ...	2EL40UNJ...	0.015	0.02	0.02			
		36	2ER36UNJ...	2EL36UNJ...	0.016	0.02	0.02			
		32	2ER32UNJ...	2EL32UNJ...	0.018	0.02	0.03			
		28	2ER28UNJ...	2EL28UNJ...	0.020	0.03	0.03			
		24	2ER24UNJ...	2EL24UNJ...	0.024	0.03	0.03			
		20	2ER20UNJ...	2EL20UNJ...	0.029	0.03	0.04			
		18	2ER18UNJ...	2EL18UNJ...	0.032	0.03	0.04			
		16	2ER16UNJ...	2EL16UNJ...	0.036	0.04	0.04			
3/8"	0.63	14	2ER14UNJ...	2EL14UNJ...	0.041	0.04	0.05	YE3	YI3	AL..-3 (LH)
		48	3ER48UNJ...	3EL48UNJ...	0.012	0.02	0.02			
		44	3ER44UNJ...	3EL44UNJ...	0.013	0.02	0.02			
		40	3ER40UNJ...	3EL40UNJ...	0.015	0.02	0.02			
		36	3ER36UNJ...	3EL36UNJ...	0.016	0.02	0.02			
		32	3ER32UNJ...	3EL32UNJ...	0.018	0.02	0.03			
		28	3ER28UNJ...	3EL28UNJ...	0.020	0.03	0.03			
		24	3ER24UNJ...	3EL24UNJ...	0.024	0.03	0.03			
		20	3ER20UNJ...	3EL20UNJ...	0.029	0.03	0.04			
		18	3ER18UNJ...	3EL18UNJ...	0.032	0.03	0.04			
		16	3ER16UNJ...	3EL16UNJ...	0.036	0.04	0.04			
		14	3ER14UNJ...	3EL14UNJ...	0.041	0.04	0.05			
		13	3ER13UNJ...	3EL13UNJ...	0.044	0.04	0.05			
		12	3ER12UNJ...	3EL12UNJ...	0.048	0.04	0.05			
		11	3ER11UNJ...	3EL11UNJ...	0.052	0.05	0.06			
		10	3ER10UNJ...	3EL10UNJ...	0.058	0.05	0.06			
		9	3ER9UNJ...	3EL9UNJ...	0.064	0.05	0.07			
		8	3ER8UNJ...	3EL8UNJ...	0.072	0.05	0.06			



Continued on next page ▶

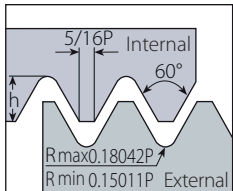
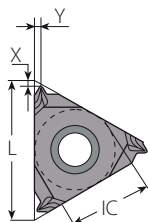
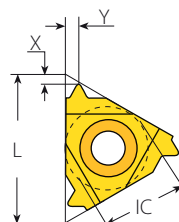
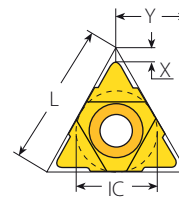

**UNJ - UNJC, UNJF, UNJEF, UNJS (con't)**
**External**

 Defined by: MIL-S-8879C  
 Tolerance class: 3A/3B

**SCB**  
 Sintered  
 Chipbreaker

**Standard**

**U Style**
**Standard (con't)**

Insert Size		Pitch	Ordering Code		Dimensions inch			Anvil		Toolholder
IC	L inch	tpi	RH	LH	h min	X	Y	RH	LH	
 3/8" SCB	0.63	36	3JER36UNJ...		0.016	0.05	0.02	YE3	-	AL..-3
		32	3JER32UNJ...		0.018	0.05	0.02			
		28	3JER28UNJ...		0.020	0.03	0.03			
		24	3JER24UNJ...		0.024	0.03	0.03			
		20	3JER20UNJ...		0.029	0.03	0.03			
		18	3JER18UNJ...		0.032	0.03	0.03			
		16	3JER16UNJ...		0.036	0.03	0.03			
		14	3JER14UNJ...		0.041	0.05	0.06			
		12	3JER12UNJ...		0.048	0.05	0.06			
		10	3JER10UNJ...		0.058	0.05	0.06			
 1/2"	0.87	7	4ER7UNJ...	4EL7UNJ...	0.082	0.07	0.09	YE4	Y14	AL..-4 (LH)
		6	4ER6UNJ...	4EL6UNJ...	0.096	0.07	0.09			
		5	4ER5UNJ...	4EL5UNJ...	0.115	0.07	0.10			
5/8"	1.06	4.5	5ER4.5UNJ...	5EL4.5UNJ...	0.128	0.08	0.11	YE5	Y15	AL..-5 (LH)
		4	5ER4UNJ...	5EL4UNJ...	0.144	0.09	0.12			

**U Style**



Insert Size		Pitch	Ordering Code	Dimensions inch			Anvil		Toolholder
IC	L inch	tpi	RH+LH	h min	X	Y	RH	LH	
1/2"U	0.87	4.5	4UE4.5UNJ...	0.128	0.08	0.43	YE4U	Y14U	AL..-4U (LH)
		4	4UE4UNJ...	0.144	0.09	0.43			

# UNJ - UNJC, UNJF, UNJEF, UNJS (con't)

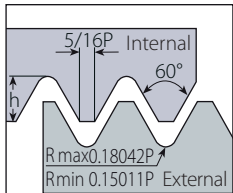
## Internal

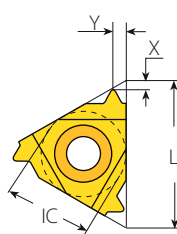

Defined by: MIL-S-8879C  
Tolerance class: 3A/3B



Standard

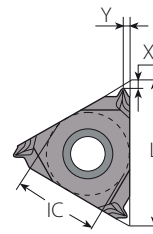

SCB  
Sintered  
Chipbreaker

## Standard

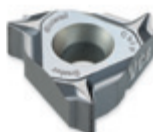

SCB

Insert Size		Pitch	Ordering Code		Dimensions inch			Anvil		Toolholder
IC	L inch	tpi	RH	LH	h min	X	Y	RH	LH	
1/4"	0.43	48	2IR48UNJ...	2IL48UNJ...	0.011	0.02	0.02	-	-	NVR..-2 (LH)
		44	2IR44UNJ...	2IL44UNJ...	0.012	0.02	0.02			
		40	2IR40UNJ...	2IL40UNJ...	0.013	0.02	0.02			
		36	2IR36UNJ...	2IL36UNJ...	0.015	0.02	0.02			
		32	2IR32UNJ...	2IL32UNJ...	0.017	0.02	0.03			
		28	2IR28UNJ...	2IL28UNJ...	0.019	0.03	0.03			
		24	2IR24UNJ...	2IL24UNJ...	0.022	0.03	0.03			
		20	2IR20UNJ...	2IL20UNJ...	0.026	0.03	0.04			
		18	2IR18UNJ...	2IL18UNJ...	0.029	0.03	0.04			
		16	2IR16UNJ...	2IL16UNJ...	0.033	0.04	0.04			
1/4" SCB	0.43	36	2JIR36UNJ...		0.015	0.04	0.02	-	-	NVR..-2
		32	2JIR32UNJ...		0.017	0.05	0.02			
		28	2JIR28UNJ...		0.019	0.02	0.03			
		24	2JIR24UNJ...		0.022	0.02	0.03			
		20	2JIR20UNJ...		0.026	0.02	0.03			
		18	2JIR18UNJ...		0.029	0.02	0.03			
		16	2JIR16UNJ...		0.033	0.02	0.03			
		14	2JIR14UNJ...		0.037	0.02	0.03			

Continued on next page ▶

# UNJ - UNJC, UNJF, UNJEF, UNJS (con't)

## Internal

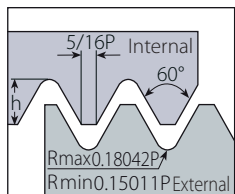

Defined by: MIL-S-8879C  
Tolerance class: 3A/3B

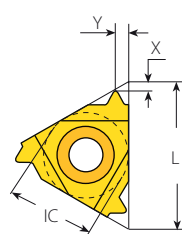

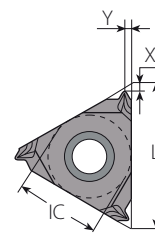

Standard

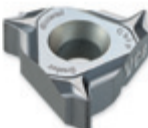

SCB  
Sintered  
Chipbreaker

## Standard (con't)

Insert Size		Pitch	Ordering Code		Dimensions inch			Anvil		Toolholder												
IC	L inch	tpi	RH	LH	h min	X	Y	RH	LH													
	3/8"	0.63	48	3IR48UNJ...	3IL48UNJ...	0.011	0.02	0.02	YI3	YE3	AVR..-3 (LH)											
			44	3IR44UNJ...	3IL44UNJ...	0.012	0.02	0.02														
			40	3IR40UNJ...	3IL40UNJ...	0.013	0.02	0.02														
			36	3IR36UNJ...	3IL36UNJ...	0.015	0.02	0.02														
			32	3IR32UNJ...	3IL32UNJ...	0.017	0.02	0.03														
			28	3IR28UNJ...	3IL28UNJ...	0.019	0.03	0.03														
			24	3IR24UNJ...	3IL24UNJ...	0.022	0.03	0.03														
			20	3IR20UNJ...	3IL20UNJ...	0.026	0.03	0.04														
			18	3IR18UNJ...	3IL18UNJ...	0.029	0.03	0.04														
			16	3IR16UNJ...	3IL16UNJ...	0.033	0.04	0.04														
			14	3IR14UNJ...	3IL14UNJ...	0.037	0.04	0.05														
			13	3IR13UNJ...	3IL13UNJ...	0.040	0.04	0.05														
			12	3IR12UNJ...	3IL12UNJ...	0.044	0.04	0.05														
			11	3IR11UNJ...	3IL11UNJ...	0.048	0.05	0.06														
			10	3IR10UNJ...	3IL10UNJ...	0.052	0.05	0.06														
 SCB	3/8"	0.63	28	3JIR28UNJ...		0.019	0.02	0.03	YI3	-	AVR..-3											
			24	3JIR24UNJ...		0.022	0.02	0.03														
			20	3JIR20UNJ...		0.026	0.02	0.03														
			18	3JIR18UNJ...		0.029	0.02	0.03														
			16	3JIR16UNJ...		0.033	0.02	0.03														
			14	3JIR14UNJ...		0.037	0.04	0.06														
			12	3JIR12UNJ...		0.044	0.04	0.06														
			10	3JIR10UNJ...		0.052	0.04	0.06														
			8	3JIR8UNJ...		0.065	0.04	0.06														
				1/2"	0.87	7	4IR7UNJ...	4IL7UNJ...				0.075	0.07	0.09	YI4	YE4	AVR..-4 (LH)					
						6	4IR6UNJ...	4IL6UNJ...				0.087	0.07	0.09								
						5	4IR5UNJ...	4IL5UNJ...				0.105	0.07	0.10								
						5/8"	1.06	4.5				5IR4.5UNJ...	5IL4.5UNJ...	0.116				0.08	0.11	YI5	YE5	AVR..-5 (LH)
								4				5IR4UNJ...	5IL4UNJ...	0.131				0.09	0.09			

# UNJ - UNJC, UNJF, UNJEF, UNJS (con't)

## Internal

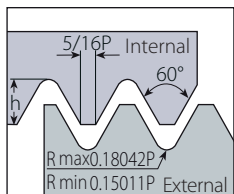

Defined by: MIL-S-8879C  
Tolerance class: 3A/3B

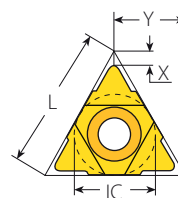

U Style

## U Style



Insert Size		Pitch	Ordering Code	Dimensions inch			Anvil		Toolholder
IC	L inch	tpi	RH+LH	h min	X	Y	RH	LH	
1/2"U	0.87	4.5	4UI4.5UNJ...	0.116	0.08	0.43	YI4U	YE4U	AVR...-4U (LH)
		4	4UI4UNJ...	0.131	0.09	0.43			

# UNJ - UNJC, UNJF, UNJEF, UNJS (con't)



## Internal

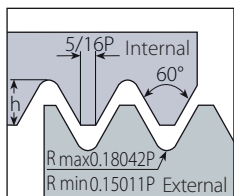

Defined by: MIL-S-8879C  
Tolerance class: 3A/3B

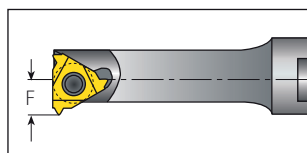
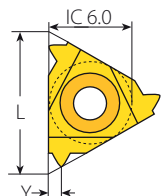

Mini-3

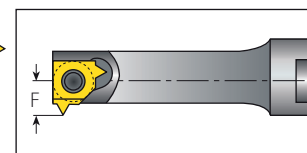
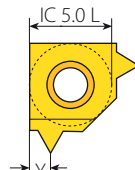

Mini-L

## Mini-3



Insert Size		Pitch	Ordering Code	Dimensions inch			Min. Bore dia.	Toolholder
IC	L inch	tpi	RH	h min	Y	F	inch	
6.0	0.39	20	6.0IR20UNJ...	0.026	0.04	0.19	0.39	.NVR...-6.0

## Mini-L



Insert Size		Pitch	Ordering Code	Dimensions inch			Min. Bore dia.	Toolholder
IC mm		tpi	RH	h min	Y	F	inch	
5.0L		32	5LIR32UNJ...	0.017	0.02	0.15	0.30	.NVR... -5L
		28	5LIR28UNJ...	0.019	0.02	0.16	0.30	
		20	5LIR20UNJ...	0.026	0.04	0.17	0.31	
		18	5LIR18UNJ...	0.029	0.04	0.17	0.31	
		16	5LIR16UNJ...	0.033	0.04	0.17	0.31	
	14	5LIR14UNJ...	0.037	0.04	0.18	0.31		

Left Handed Tool Supplied by Request. (Example: 6.0IL20UNJ...)

# MJ

## External

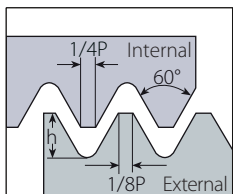

Defined by: ISO 5855  
Tolerance class: 4h/6h-4H/5H

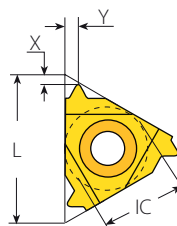

External - Standard

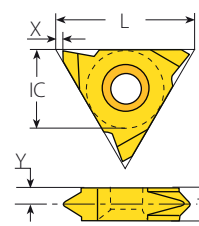

Slim Throat

## Standard



Insert Size		Pitch	Ordering Code		Dimensions inch			Anvil		Toolholder
IC	L inch	mm	RH	LH	h min	X	Y	RH	LH	
1/4"	0.43	1.0	2ER1.0MJ...	2EL1.0MJ...	0.023	0.03	0.03	-	-	NL..-2 (LH)
		1.25	2ER1.25MJ...	2EL1.25MJ...	0.028	0.03	0.04			
		1.5	2ER1.5MJ...	2EL1.5MJ...	0.034	0.03	0.04			
3/8"	0.63	0.7	3ER0.7MJ...	3EL0.7MJ...	0.016	0.02	0.02	YE3	YI3	AL..-3 (LH)
		1.0	3ER1.0MJ...	3EL1.0MJ...	0.023	0.03	0.03			
		1.25	3ER1.25MJ...	3EL1.25MJ...	0.028	0.03	0.04			
		1.5	3ER1.5MJ...	3EL1.5MJ...	0.034	0.03	0.04			
		2.0	3ER2.0MJ...	3EL2.0MJ...	0.045	0.04	0.05			
		2.5	3ER2.5MJ...	3EL2.5MJ...	0.059	0.04	0.06			
3.0	3ER3.0MJ...	3EL3.0MJ...	0.068	0.05	0.06					

## Slim Throat



Insert Size		Pitch	Ordering Code		Dimensions inch				Toolholder
IC	L inch	mm	RH	LH	h min	X	Y	T	
1/4"V	0.43	0.7	2VER0.7MJ	2VEL0.7MJ	0.016	0.03	0.10	0.13	NL..-2V (LH)
		0.8	2VER0.8MJ	2VEL0.8MJ	0.017	0.03	0.10	0.13	
		0.9	2VER0.9MJ	2VEL0.9MJ	0.021	0.03	0.10	0.13	
		1.0	2VER1.0MJ	2VEL1.0MJ	0.023	0.03	0.10	0.13	
		1.25	2VER1.25MJ	2VEL1.25MJ	0.028	0.03	0.09	0.13	
		1.5	2VER1.5MJ	2VEL1.5MJ	0.034	0.03	0.09	0.13	

# MJ

## Internal

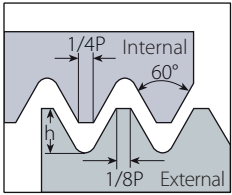

Defined by: ISO 5855  
Tolerance class: 4h/6h-4H/5H

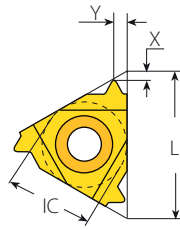

Internal - Standard

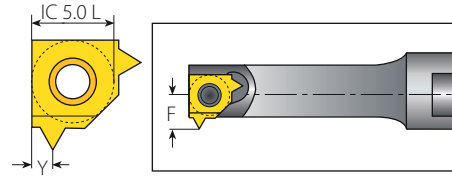

Mini-L

## Standard



Insert Size		Pitch	Ordering Code		Dimensions inch			Anvil		Toolholder
IC	L inch	mm	RH	LH	h min	X	Y	RH	LH	
1/4"	0.43	1.0	2IR1.0MJ...	2IL1.0MJ...	0.019	0.02	0.03	-	-	NVR...-2 (LH)
		1.25	2IR1.25MJ...	2IL1.25MJ...	0.024	0.03	0.04			
		1.5	2IR1.5MJ...	2IL1.5MJ...	0.029	0.03	0.04			
		2.0	2IR2.0MJ...	2IL2.0MJ...	0.038	0.03	0.04			
3/8"	0.63	0.75	3IR0.75MJ...	3IL0.75MJ...	0.015	0.02	0.02	Y13	YE3	AVR...-3 (LH)
		1.0	3IR1.0MJ...	3IL1.0MJ...	0.019	0.02	0.03			
		1.25	3IR1.25MJ...	3IL1.25MJ...	0.024	0.03	0.04			
		1.5	3IR1.5MJ...	3IL1.5MJ...	0.029	0.03	0.04			
		2.0	3IR2.0MJ...	3IL2.0MJ...	0.038	0.03	0.05			
		2.5	3IR2.5MJ...	3IL2.5MJ...	0.048	0.04	0.06			
		3.0	3IR3.0MJ...	3IL3.0MJ...	0.057	0.05	0.06			

## Mini - L



Insert Size		Pitch	Ordering Code	Dimensions inch			Min. Bore dia.	Toolholder
IC	mm	mm	RH	h min	Y	F	inch	
5.0L		1.0	5LIR1.0MJ...	0.019	0.03	0.16	0.30	.NVR...-5L
		1.25	5LIR1.25MJ...	0.024	0.04	0.17	0.31	
		1.5	5LIR1.50MJ...	0.029	0.04	0.17	0.31	

# American Buttress

## External

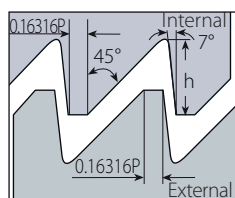

Defined by: ANSI B1.9.1973  
Tolerance class: Class 2

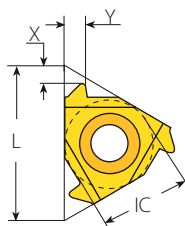

Standard

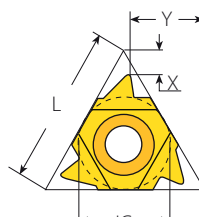

U Style

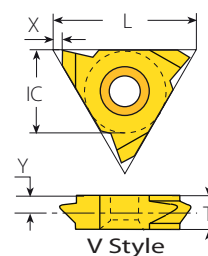

V Style

## Standard



Insert Size		Pitch	Ordering Code		Dimensions inch			Anvil		Toolholder
IC	L inch	tpi	RH	LH	h min	X	Y	RH	LH	
1/4"	0.43	20	2ER20ABUT...	2EL20ABUT...	0.033	0.04	0.06	-	-	NL..-2 (LH)
		16	2ER16ABUT...	2EL16ABUT...	0.041	0.05	0.07	-	-	
3/8"	0.63	20	3ER20ABUT...	3EL20ABUT...	0.033	0.04	0.06	YE3	YI3	AL..-3 (LH)
		16	3ER16ABUT...	3EL16ABUT...	0.041	0.05	0.07			
		12	3ER12ABUT...	3EL12ABUT...	0.055	0.06	0.08			
1/2"	0.87	10	3ER10ABUT...	3EL10ABUT...	0.066	0.06	0.09	YE4	YI4	AL..-4 (LH)
		8	4ER8ABUT...	4EL8ABUT...	0.083	0.08	0.13			
		6	4ER6ABUT...	4EL6ABUT...	0.110	0.09	0.14			

## U Style



Insert Size		Pitch	Ordering Code		Dimensions inch			Anvil		Toolholder
IC	L inch	tpi	RH	LH	h min	X	Y	RH	LH	
1/2"U	0.87	4	4UER4ABUT...	4UEL4ABUT...	0.166	0.09	0.39	YE4U-BUT4	YI4U-BUT4	AL..-4U (LH)
5/8"U	1.06	3	5UER3ABUT...	5UEL3ABUT...	0.221	0.12	0.48	YE5U-BUT3	YI5U-BUT3	AL..-5U (LH)

## V Style



Insert Size		Pitch	Ordering Code		Dimensions inch			T	Toolholder
IC	L inch	tpi	RH	LH	h min	X	Y		
5/8"V	1.06	4	5VER4ABUT...	5VEL4ABUT...	0.166	0.02	0.07	0.24	NL..-5V-6 (LH)
		3	5VER3ABUT...	5VEL3ABUT...	0.221	0.02	0.09	0.31	NL..-5V-8 (LH)
		2.5	5VER2.5ABUT...	5VEL2.5ABUT...	0.265	0.02	0.11	0.39	NL..-5V-10ABUT (LH)

# American Buttress (con't)

## Internal

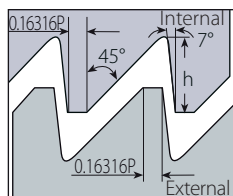

Defined by: ANSI B1.9.1973  
Tolerance class: Class 2

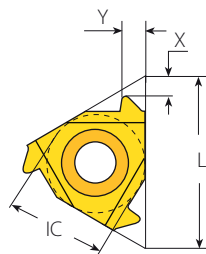

Standard

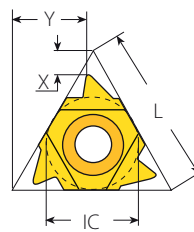

U Style

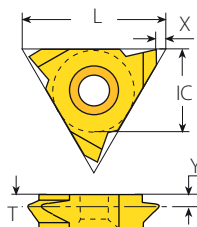

V Style

## Standard



Insert Size		Pitch	Ordering Code		Dimensions inch			Anvil		Toolholder
IC	L inch	tpi	RH	LH	h min	X	Y	RH	LH	
1/4"	0.43	20	2IR20ABUT...	2IL20ABUT...	0.033	0.04	0.06	-	-	NVR..-2 (LH)
		16	2IR16ABUT...	2IL16ABUT...	0.041	0.05	0.07	-	-	
3/8"	0.63	20	3IR20ABUT...	3IL20ABUT...	0.033	0.04	0.06	YI3	YE3	AVR..-3 (LH)
		16	3IR16ABUT...	3IL16ABUT...	0.041	0.05	0.07			
		12	3IR12ABUT...	3IL12ABUT...	0.055	0.06	0.08			
		10	3IR10ABUT...	3IL10ABUT...	0.066	0.06	0.09			
1/2"	0.87	8	4IR8ABUT...	4IL8ABUT...	0.083	0.08	0.13	YI4	YE4	AVR..-4 (LH)
		6	4IR6ABUT...	4IL6ABUT...	0.110	0.09	0.14			



## U Style

Insert Size		Pitch	Ordering Code		Dimensions inch			Anvil		Toolholder
IC	L inch	tpi	RH	LH	h min	X	Y	RH	LH	
1/2"U	0.87	4	4UIR4ABUT...	4UIL4ABUT...	0.166	0.09	0.39	YI4U-4B	YE4U-4B	AVR..-4U (LH)
5/8"U	1.06	3	5UIR3ABUT...	5UIL3ABUT...	0.221	0.12	0.48	YI5U-3B	YE5U-3B	AVR..-5U (LH)



## V Style

Insert Size		Pitch	Ordering Code		Dimensions inch				Toolholder
IC	L inch	tpi	RH	LH	h min	X	Y	T	
5/8"V	1.06	4	5VIR4ABUT...	5VIL4ABUT...	0.166	0.02	0.07	0.24	NVR..-5V (LH)
		3	5VIR3ABUT...	5VIL3ABUT...	0.221	0.02	0.09	0.31	
		2.5	5VIR2.5ABUT...	5VIL2.5ABUT...	0.265	0.02	0.11	0.39	





## British Buttress

### External

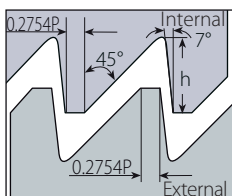

Defined by: B.S. 1657: 1950  
Tolerance class: Medium Class

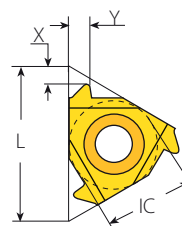

Standard

### Standard



Insert Size		Pitch	Ordering Code		Dimensions inch			Anvil		Toolholder
IC	L inch	tpi	RH	LH	h min	X	Y	RH	LH	
3/8"	0.63	16	3ER16BBUT...	3EL16BBUT...	0.031	0.04	0.06	YE3	YI3	AL...-3 (LH)
		12	3ER12BBUT...	3EL12BBUT...	0.042	0.06	0.08			
		10	3ER10BBUT...	3EL10BBUT...	0.050	0.06	0.09			
		8	3ER8BBUT...	3EL8BBUT...	0.063	0.06	0.10			
1/2"	0.87	8	4ER8BBUT...	4EL8BBUT...	0.063	0.06	0.10	YE4	YI4	AL...-4 (LH)

## British Buttress

### Internal

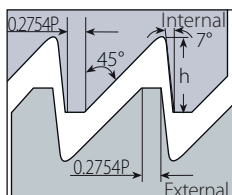

Defined by: B.S. 1657: 1950  
Tolerance class: Medium Class

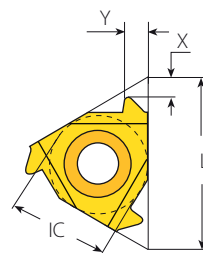

Standard

### Standard



Insert Size		Pitch	Ordering Code		Dimensions inch			Anvil		Toolholder
IC	L inch	tpi	RH	LH	h min	X	Y	RH	LH	
3/8"	0.63	16	3IR16BBUT...	3IL16BBUT...	0.031	0.04	0.06	YI3	YE3	AVR...-3 (LH)
		12	3IR12BBUT...	3IL12BBUT...	0.042	0.06	0.08			
		10	3IR10BBUT...	3IL10BBUT...	0.050	0.06	0.09			
		8	3IR8BBUT...	3IL8BBUT...	0.063	0.06	0.10			
1/2"	0.87	8	4IR8BBUT...	4IL8BBUT...	0.063	0.06	0.10	YI4	YE4	AVR...-4 (LH)

# Metric Buttress (Sägengewinde)

## External / Internal

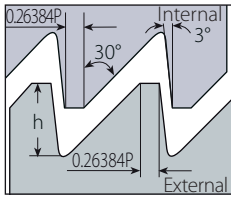

Defined by: DIN 513  
Tolerance class: Medium Class

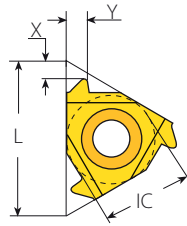

External Standard

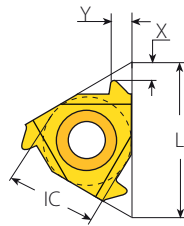

Internal Standard

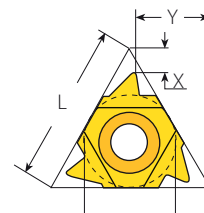

External U Style

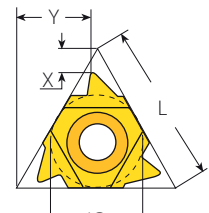

Internal U Style

## Standard - External



Insert Size		Pitch	Ordering Code		Dimensions inch			Anvil		Toolholder
IC	L inch	mm	RH	LH	h min	X	Y	RH	LH	
3/8"	0.63	2.0	3ER2.0SAGE...	3EL2.0SAGE...	0.069	0.06	0.08	YE3	YI3	AL..-3 (LH)
		2.0	4ER2.0SAGE...	4EL2.0SAGE...	0.069	0.06	0.08			
1/2"	0.87	3.0	4ER3.0SAGE...	4EL3.0SAGE...	0.102	0.07	0.10	YE4	YI4	AL..-4 (LH)
		4.0	4ER4.0SAGE...	4EL4.0SAGE...	0.140	0.07	0.12			
5/8"	1.06	4.0	5ER4.0SAGE...	5EL4.0SAGE...	0.140	0.07	0.13	YE5 082/038	YI5 082/039	AL..-5 (LH)

## U Style - External



Insert Size		Pitch	Ordering Code		Dimensions inch			Anvil		Toolholder
IC	L inch	mm	RH	LH	h min	X	Y	RH	LH	
1/2"U	0.87	5	4UER5.0SAGE...	4UEL5.0SAGE...	0.174	0.05	0.41	YE4U-SAGE5	YI4U-SAGE5	AL..-4U (LH)
		6	4UER6.0SAGE...	4UEL6.0SAGE...	0.208	0.05	0.40	YE4U-SAGE6	YI4U-SAGE6	

## Standard - Internal



Insert Size		Pitch	Ordering Code		Dimensions inch			Anvil		Toolholder
IC	L inch	mm	RH	LH	h min	X	Y	RH	LH	
3/8"	0.63	2.0	3IR2.0SAGE...	3IL2.0SAGE...	0.059	0.06	0.09	YI3	YE3	AVR..-3 (LH)
		3.0	4IR3.0SAGE...	4IL3.0SAGE...	0.089	0.07	0.11	YI4	YE4	AVR..-4 (LH)
1/2"	0.87	4.0	4IR4.0SAGE...	4IL4.0SAGE...	0.122	0.08	0.13			
		4.0	5IR4.0SAGE...	5IL4.0SAGE...	0.122	0.08	0.13	YI5 082/039	YE5 082/038	AVR..-5 (LH)

## U Style - Internal



Insert Size		Pitch	Ordering Code		Dimensions inch			Anvil		Toolholder
IC	L inch	mm	RH	LH	h min	X	Y	RH	LH	
1/2"U	0.87	5	4UIR5.0SAGE...	4UIL5.0SAGE...	0.148	0.07	0.41	YI4U-5S	YE4U-5S	AVR..-4U (LH)
		6	4UIR6.0SAGE...	4UIL6.0SAGE...	0.179	0.07	0.40	YI4U-6S	YE4U-6S	

# API

## External / Internal

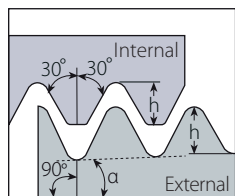

$$\alpha = \arctg (IPF/24)$$

Defined by: API SPEC. 7:1990  
Tolerance class: Standard API

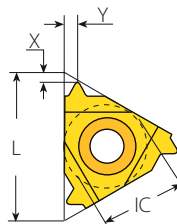

External - Standard

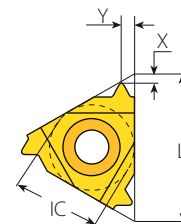

Internal - Standard

## Standard - External



Insert Size		Pitch	Thread	Taper	Ordering Code	Size	Dimensions inch			Anvil	
IC	L inch	tpi		IPF	RH		h min	X	Y	RH	Toolholder
1/2"	0.87	4	V-0.038R	2	4ER4API382...	NC23-NC50	0.122	0.08	0.11	YE4	AL..-4 (LH)
		4	V-0.038R	3	4ER4API383...	NC56-NC77	0.121	0.08	0.11		
		4	V-0.050	2	4ER4API502...	6 5/8" REG	0.148	0.08	0.11		
		4	V-0.050	3	4ER4API503...	5 1/2", 7 5/8", 8 5/8" REG	0.147	0.08	0.11		
		5	V-0.040	3	4ER5API403...	2 3/8"-4 1/2" REG	0.118	0.07	0.10		
		6	V-0.055	1.5	4ER6API551...	NC10-NC16	0.056	0.10	0.08		
5/8"	1.06	4	V-0.038R	2	5ER4API382...	NC23-NC50	0.122	0.08	0.11	YE5OIL	AL..-5 OIL (LH)
		4	V-0.038R	3	5ER4API383...	NC56-NC77	0.121	0.08	0.11		
		4	V-0.050	2	5ER4API502...	6 5/8" REG	0.148	0.08	0.12		
		4	V-0.050	3	5ER4API503...	5 1/2", 7 5/8", 8 5/8" REG	0.147	0.08	0.12		
		5	V-0.040	3	5ER5API403...	2 3/8"-4 1/2" REG	0.118	0.07	0.11		

## Standard - Internal



Insert Size		Pitch	Thread	Taper	Ordering Code	Size	Dimensions inch			Anvil	
IC	L inch	tpi		IPF	RH		h min	X	Y	RH	Toolholder
1/2"	0.87	4	V-0.038R	2	4IR4API382...	NC23-NC50	0.122	0.08	0.11	YI4	AVR..-4 (LH)
		4	V-0.038R	3	4IR4API383...	NC56-NC77	0.121	0.08	0.11		
		4	V-0.050	2	4IR4API502...	6 5/8" REG	0.148	0.08	0.12		
		4	V-0.050	3	4IR4API503...	5 1/2", 7 5/8", 8 5/8" REG	0.147	0.08	0.11		
		5	V-0.040	3	4IR5API403...	2 3/8"-4 1/2" REG	0.118	0.07	0.10		
		6	V-0.055	1.5	4IR6API551...	NC10-NC16	0.056	0.10	0.08		
5/8"	1.06	4	V-0.038R	2	5IR4API382...	NC23-NC50	0.122	0.08	0.11	YI5OIL	AVR..-5 OIL (LH)
		4	V-0.038R	3	5IR4API383...	NC56-NC77	0.121	0.08	0.11		
		4	V-0.050	2	5IR4API502...	6 5/8" REG	0.148	0.08	0.12		
		4	V-0.050	3	5IR4API503...	5 1/2", 7 5/8", 8 5/8" REG	0.147	0.08	0.12		
		5	V-0.040	3	5IR5API403...	2 3/8"-4 1/2" REG	0.118	0.07	0.11		

# API Buttress Casing

## External

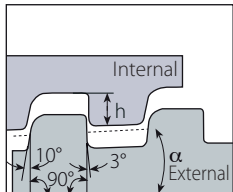

$$\alpha = \arctg (IPF/24)$$

Defined by: STD.5B:1979  
Tolerance class: Standard API

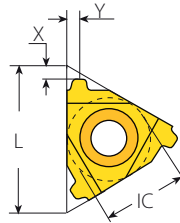

Standard

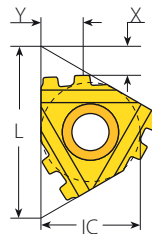

M+ Style

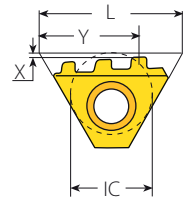

T+ Style

## Standard



Insert Size		Pitch	Taper	Ordering Code	Size	Dimensions inch			Anvil	Toolholder
IC	L inch	tpi	IPF	RH		h min	X	Y	RH	
1/2"	0.87	5	0.75	4ER5BUT75...	4 1/2"-13 3/8"	0.061	0.12	0.07	YE4	AL...-4
		5	1	4ER5BUT1...	16"-20"	0.061	0.12	0.07		

## M+ Style



Insert Size		Pitch	Taper	Teeth	Ordering Code	Size	Dimensions inch			Anvil	Toolholder
IC	L inch	tpi	IPF		RH		h min	X	Y	RH	
5/8"	1.06	5	0.75	2	5ER5BUT752M+...	4 1/2"-13 3/8"	0.061	0.19	0.27	YE5M	AL...-5M

## T+ Style



Insert Size		Pitch	Taper	Teeth	Ordering Code	Size	Dimensions inch			Anvil	Toolholder
IC	L inch	tpi	IPF		RH		h min	X	Y	RH	
1/2" T	0.87	5	0.75	3	4ER5BUT753T+...	4 1/2"-13 3/8"	0.061	0.10	0.63	Y4T	AL...-4T

# API Buttress Casing

## Internal

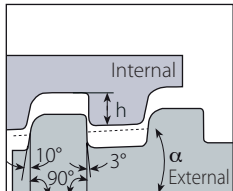

$$\alpha = \arctg (IPF/24)$$

Defined by: STD.5B:1979  
Tolerance class: Standard API

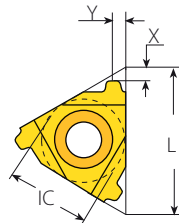

Standard

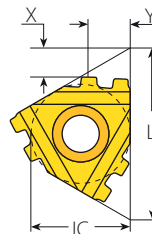

M+ Style

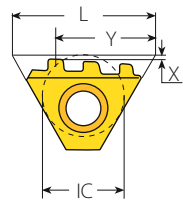

T+ Style

## Standard



Insert Size		Pitch	Taper	Ordering Code	Size	Dimensions inch			Anvil	Toolholder
IC	L inch	tpi	IPF	RH		h min	X	Y	RH	
1/2"	0.87	5	0.75	4IR5BUT75...	4 1/2"-13 3/8"	0.061	0.11	0.07	YI4	AVR...-4
		5	1	4IR5BUT1...	16"-20"	0.061	0.11	0.07		

## M+ Style



Insert Size		Pitch	Taper	Teeth	Ordering Code	Size	Dimensions inch			Anvil	Toolholder
IC	L inch	tpi	IPF		RH		h min	X	Y	RH	
5/8"	1.06	5	0.75	2	5IR5BUT752M+...	4 1/2"-13 3/8"	0.061	0.19	0.26	YI5M	AVR...-5M

## T+ Style



Insert Size		Pitch	Taper	Teeth	Ordering Code	Size	Dimensions inch			Anvil	Toolholder
IC	L inch	tpi	IPF		RH		h min	X	Y	RH	
1/2" T	0.87	5	0.75	3	4IR5BUT753T+...	4 1/2"-13 3/8"	0.061	0.10	16.1	Y4T	AVR...-4T

# API Round Casing & Tubing

## External

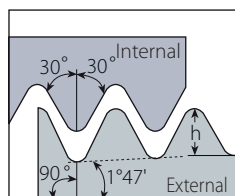

Defined by: API STD. 5B:1979  
 Tolerance class: Standard API RD

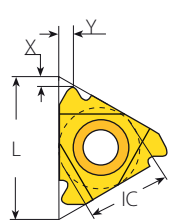

Standard

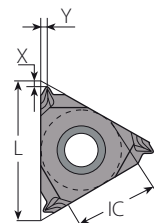

SCB  
 Sintered  
 Chipbreaker

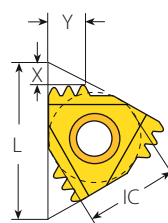

M+ Style

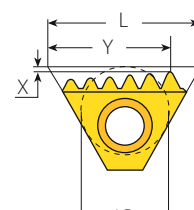

T+ Style

## Standard



SCB

Insert Size		Pitch	Ordering Code		Dimensions inch			Anvil	Toolholder
IC	L inch	tpi	RH		h min	X	Y	RH	Toolholder
3/8"	0.63	10	3ER10APIRD...		0.056	0.05	0.06	YE3	AL..-3
		8	3ER8APIRD...		0.071	0.05	0.06		
3/8" SCB	0.63	10	3JER10APIRD...		0.056	0.05	0.06	YE3	AL..-3
		8	3JER8APIRD...		0.071	0.05	0.06		

Multiplus

## M+ Style



Insert Size		Pitch	Teeth	Ordering Code		Dimensions inch			Anvil	Toolholder
IC	L inch	tpi		RH		h min	X	Y	RH	Toolholder
5/8"	1.06	10	3	5ER10APIRD3M+...		0.056	0.15	0.25	YE5M	AL..-5M
		8	2	5ER8APIRD2M+...		0.071	0.11	0.18		

Multiplus

## T+ Style



Insert Size		Pitch	Teeth	Ordering Code		Dimensions inch			Anvil	Toolholder
IC	L inch	tpi		RH		h min	X	Y	RH	Toolholder
1/2"T	0.87	10	6	4ER10APIRD6T+...		0.056	0.01	0.64	Y4T	AL..-4T
		8	3	4ER8APIRD3T+...		0.071	0.01	0.56		
		8	5	4ER8APIRD5T+...		0.071	0.01	0.66		

# API Round Casing & Tubing (con't)

## Internal

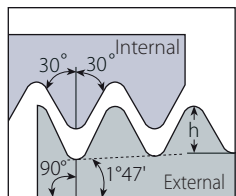

Defined by: API STD. 5B:1979  
Tolerance class: Standard API RD

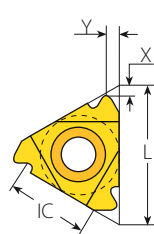

Standard

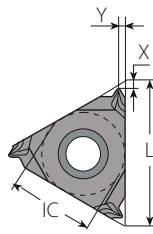

SCB  
Sintered  
Chipbreaker

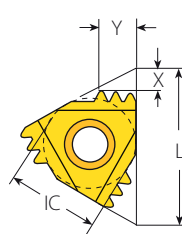

M+ Style

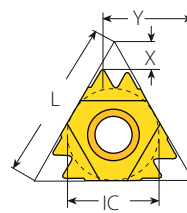

Z+ Style

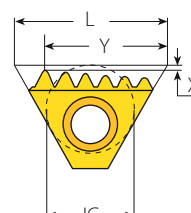

T+ Style

## Standard

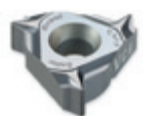

SCB

Insert Size		Pitch	Ordering Code		Dimensions inch			Anvil	Toolholder
IC	L inch	tpi	RH		h min	X	Y	RH	Toolholder
3/8"	0.63	10	3IR10APIRD...		0.056	0.05	0.06	Y13	AVR..-3
		8	3IR8APIRD...		0.071	0.05	0.06		
3/8" SCB	0.63	10	3JIR10APIRD...		0.056	0.05	0.06	Y13	AVR..-3
		8	3JIR8APIRD...		0.071	0.05	0.06		

## M+ Style



Insert Size		Pitch	Teeth	Ordering Code		Dimensions inch			Anvil	Toolholder
IC	L inch	tpi		RH		h min	X	Y	RH	Toolholder
1/2"	0.87	10	2	4IR10APIRD2M+...		0.056	0.09	0.15	Y14M	AVR..-4
		8	2	4IR8APIRD2M+...		0.071	0.11	0.18		
5/8"	1.06	10	3	5IR10APIRD3M+...		0.056	0.15	0.25	Y15M	AVR..-5M
		8	2	5IR8APIRD2M+...		0.071	0.11	0.18		

## Z+ Style



Insert Size		Pitch	Teeth	Ordering Code		Dimensions inch			Anvil	Toolholder
IC	L inch	tpi		RH		h min	X	Y	RH	Toolholder
1/2"	0.87	8	2	4IR8APIRD2Z+...		0.071	0.15	0.38	Y14Z	AVR..-4Z

## T+ Style



Insert Size		Pitch	Teeth	Ordering Code		Dimensions inch			Anvil	Toolholder
IC	L inch	tpi		RH		h min	X	Y	RH	Toolholder
1/2"	0.87	10	6	4IR10APIRD6T+...		0.056	0.01	0.66	Y4T	AVR..-4T
		8	3	4IR8APIRD3T+...		0.071	0.01	0.56		
		8	5	4IR8APIRD5T+...		0.071	0.01	0.66		

# VAM

## External / Internal

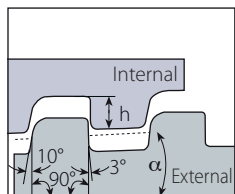

$\alpha = \arctg(IPF/24)$

Defined by: VAM  
Tolerance class: Standard VAM

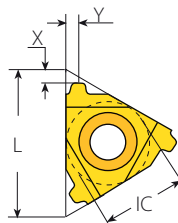

External - Standard

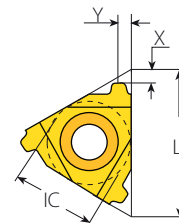

Internal - Standard

## Standard - External



Insert Size		Pitch	Taper	Ordering Code	Size	Dimensions inch			Anvil	Toolholder
IC	L inch	tpi	IPF	RH		h min	X	Y	RH	
3/8"	0.63	8	0.75	3ER8VAM...	2 3/8", 2 7/8"	0.038	0.07	0.07	YE3	AL...-3
		6	0.75	4ER6VAM...	3 1/2"	0.038	0.09	0.09	YE4	AL...-4
1/2"	0.87	5	0.75	4ER5VAM...	5"-9 5/8"	0.061	0.09	0.11		

## Standard - Internal



Insert Size		Pitch	Taper	Ordering Code	Size	Dimensions inch			Anvil	Toolholder
IC	L inch	tpi	IPF	RH		h min	X	Y	RH	
3/8"	0.63	8	0.75	3IR8VAM...	2 3/8", 2 7/8"	0.038	0.07	0.07	YI3	AVR...-3
		6	0.75	4IR6VAM...	3 1/2"	0.038	0.10	0.10	YI4	AVR...-4
1/2"	0.87	5	0.75	4IR5VAM...	5"-9 5/8"	0.061	0.09	0.10		

# EL-Extreme Line

## External / Internal

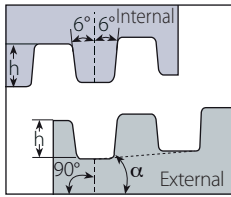

$\alpha = \arctg (IPF/24)$

Defined by: API STD,5B:1979  
Tolerance class: Standard

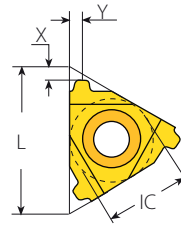

External - Standard

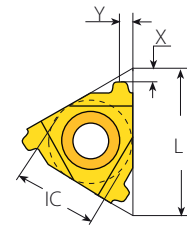

Internal - Standard

## Standard - External



Insert Size		Pitch	Taper	Ordering Code	Connection No. or Size	Dimensions inch			Anvil	
IC	L inch	tpi	IPF	RH		h min	X	Y	RH	Toolholder
1/2"	0.87	6	1.5	4ER6EL15...	5"-7 5/8"	0.048	0.07	0.07	YE4	AL...-4 (LH)
		5	1.25	4ER5EL125...	8 5/8"-10 3/4"	0.067	0.09	0.09		

## Standard - Internal



Insert Size		Pitch	Taper	Ordering Code	Connection No. or Size	Dimensions inch			Anvil	
IC	L inch	tpi	IPF	RH		h min	X	Y	RH	Toolholder
1/2"	0.87	6	1.5	4IR6EL15...	5"-7 5/8"	0.055	0.07	0.07	YI4	AVR...-4 (LH)
		5	1.25	4IR5EL125...	8 5/8"-10 3/4"	0.075	0.09	0.09		



# Hughes H-90

## External / Internal

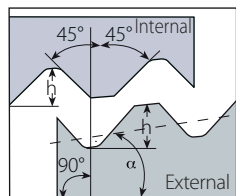

$\alpha = \arctg (IPF/24)$

Defined by: API STD,5B:1979  
Tolerance class: Standard

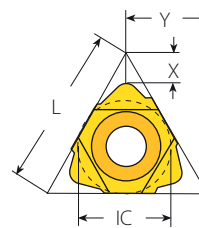

U Style

## U Style - External



Insert Size		Pitch	Taper	Ordering Code	Size	Dimensions inch			Anvil	
IC	L inch	tpi	IPF	RH		h min	X	Y	RH	Toolholder
1/2" U	0.87	3.5	2	4UER3.5H902...	3 1/2"-6 5/8"	0.098	0.17	0.43	YE4U-H90	AL..-4U (LH)
		3.5	3	4UER3.5H903...	7"-8 5/8"	0.098	0.17	0.43		
5/8" U	1.06	3	1.25*	5UER3H90SL...	2 3/8"-3 1/2"	0.088	0.22	0.54	YE5U-H90	AL..-5U (LH)

\* H-90 Slimline

## U Style - Internal



Insert Size		Pitch	Taper	Ordering Code	Size	Dimensions inch			Anvil	
IC	L inch	tpi	IPF	RH		h min	X	Y	RH	Toolholder
1/2" U	0.87	3.5	2	4UIR3.5H902...	3 1/2"-6 5/8"	0.098	0.17	0.43	YI4U-H90	AVR..-4U (LH)
		3.5	3	4UIR3.5H903...	7"-8 5/8"	0.098	0.17	0.43		
5/8" U	1.06	3	1.25*	5UIR3H90SL...	2 3/8"-3 1/2"	0.088	0.22	0.54	YI5U-H90	AVR..-5U (LH)

\* H-90 Slimline

# Pg

## External / Internal

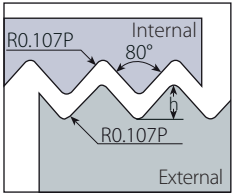

Defined by: DIN 40430  
Tolerance class: Standard

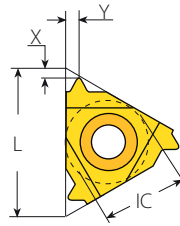

Standard External

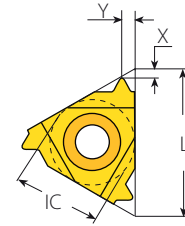

Standard Internal

## Standard - External



Insert Size		Pitch	Thread	Ordering Code		Dimensions inch			Anvil		Toolholder
IC	L inch	tpi		RH	LH	h min	X	Y	RH	LH	
1/4"	0.43	20	Pg7	2ER20PG...	2EL20PG...	0.024	0.03	0.04	-	-	NL..-2 (LH)
		18	Pg9/11/13.5/16	2ER18PG...	2EL18PG...	0.026	0.03	0.04	-	-	
		16	Pg21/29/36/42/48	2ER16PG...	2EL16PG...	0.030	0.04	0.04	-	-	
3/8"	0.63	20	Pg7	3ER20PG...	3EL20PG...	0.024	0.03	0.04	YE3	YI3	AL..-3 (LH)
		18	Pg9/11/13.5/16	3ER18PG...	3EL18PG...	0.026	0.03	0.04	YE3	YI3	
		16	Pg21/29/36/42/48	3ER16PG...	3EL16PG...	0.030	0.04	0.04	YE3	YI3	

## Standard - Internal



Insert Size		Pitch	Thread	Ordering Code		Dimensions inch			Anvil		Toolholder
IC	L inch	tpi		RH	LH	h min	X	Y	RH	LH	
1/4"	0.43	20	Pg7	2IR20PG...	2IL20PG...	0.025	0.03	0.04	-	-	NVR..-2 (LH)
		18	Pg9/11/13.5/16	2IR18PG...	2IL18PG...	0.026	0.03	0.04	-	-	
		16	Pg21/29/36/42/48	2IR16PG...	2IL16PG...	0.030	0.04	0.04	-	-	
3/8"	0.63	20	Pg7	3IR20PG...	3IL20PG...	0.025	0.03	0.04	YI3	YE3	AVR..-3 (LH)
		18	Pg11/13.5/16	3IR18PG...	3IL18PG...	0.026	0.03	0.04	YI3	YE3	
		16	Pg21/29/36/42/48	3IR16PG...	3IL16PG...	0.030	0.03	0.04	YI3	YE3	

# Pg



## Internal

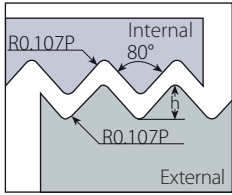

Defined by: DIN 40430  
Tolerance class: Standard

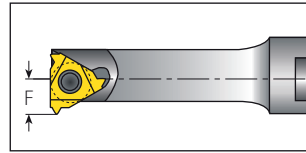
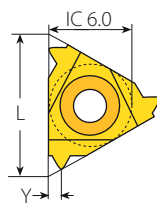

Mini-3

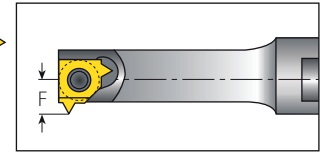
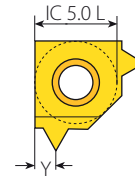

Mini-L

### Mini-3



Insert Size		Pitch	Thread	Ordering Code	Dimensions inch			Min. Bore dia.	Toolholder
IC	L inch	tpi		RH	h min	Y	F	inch	
6.0	0.39	20	Pg7	6.0IR20PG...	0.024	0.03	0.21	0.39	.NVR1..-6.0
		18	Pg9/11/13.5/16	6.0IR18PG...	0.026	0.04	0.21		

### Mini-L



Insert Size		Pitch	Thread	Ordering Code	Dimensions inch			Min. Bore dia.	Toolholder
IC		tpi		RH	h min	Y	F	inch	
5.0L		20	Pg7	5LIR20PG...	0.024	0.03	0.18	0.31	.NVR10..-5L
		18	Pg9/11/13.5/16	5LIR18PG...	0.026	0.04	0.18		





# Thread Turning

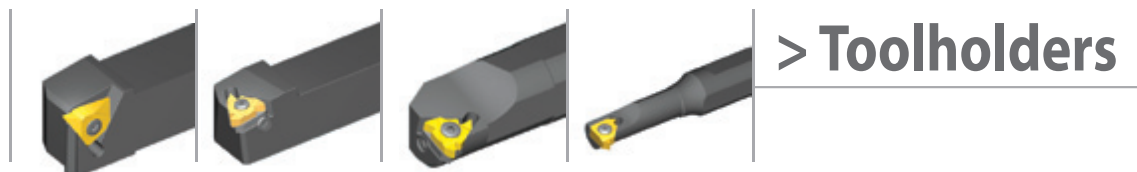

# THREAD TURNING TOOLHOLDERS

■ VARDEX Ordering Code System.....	Page 99
------------------------------------	---------

## External Toolholders

■ Standard.....	Page 100
■ Standard with clamp.....	Page 101
■ API.....	Page 101
■ U style.....	Page 102
■ U style with clamp.....	Page 102
■ Slim Throat.....	Page 103
■ V style.....	Page 104
■ Z+ style.....	Page 104
■ M+ style.....	Page 105
■ T+ style.....	Page 105
■ Off-Set Qualified (FQ).....	Page 106
■ Drop Head - Qualified (CQ).....	Page 106
■ Miniature Square Shank (External+Internal Toolholders).....	Page 107
■ Miniature Round Shank (External+Internal Toolholders).....	Page 107

## Internal Toolholders

■ Standard.....	Page 108
■ Standard for V6.....	Page 109
■ Standard for Coarse Pitch.....	Page 110
■ U style for Coarse Pitch.....	Page 110
■ Standard with clamp.....	Page 111
■ U style.....	Page 111
■ U style with clamp.....	Page 112
■ V style.....	Page 112
■ Z+ style.....	Page 113
■ M+ style.....	Page 113
■ T+ style.....	Page 114
■ API.....	Page 114
■ Standard with Carbide Shank.....	Page 115
■ Mini-3.....	Page 116
■ Mini-3-Adjustable.....	Page 116
■ Mini-L.....	Page 117
■ Mini-L-Adjustable.....	Page 117
■ Micro-Double Ended.....	Page 118
■ Spare Parts.....	Page 119

# Vardex Ordering Code System

## External Toolholders

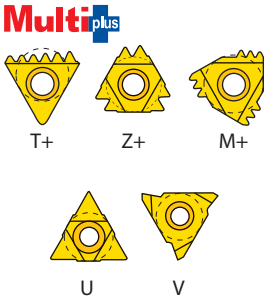
<b>A</b> 1	<b>L</b> 2	<b>125</b> 3	<b>-</b>	<b>4</b> 4	<b>U</b> 5	<b>C</b> 6	<b>7</b>	<b>8</b>	<b>9</b>
<b>1 - Anvil</b> A - Anvil required N - No Anvil required O - Miniature holder			<b>2 - Holder Style</b> L - External V - Miniature Square Shank VR - Miniature Round Shank			<b>3 - Shank Square</b> 031, 3/8, 050, 0625, 075, 100, 125, 150, 200		<b>4 - Insert Size</b> 2 - IC1/4" 3 - IC3/8" 4 - IC1/2" 5 - IC5/8"	
<b>5 - Insert Style</b>  T+    Z+    M+  U    V			<b>6 - Clamping</b> C - with Clamping			<b>7 - Insert Width [mm]</b> (for IC5/8"V) 6, 8, 10			
<b>8 - Tool Type</b> CQ - Drop Head FQ - Off-Set Oil - For API Inserts			<b>9 - RH/LH Holder</b> None - Right Hand LH - Left Hand						

## Internal Toolholders

<b>C</b> 1	<b>A</b> 2	<b>VR</b> 3	<b>C</b> 4	<b>075</b> 5	<b>6</b>	<b>-</b>	<b>3</b> 7	<b>8</b>	<b>9</b>	<b>10</b>	<b>11</b>	<b>12</b>
<b>1 - Shank Type</b> B - Anti Vibration System C - Carbide Shank S - Mini Holders			<b>2 - Anvil</b> A - Anvil required N - No Anvil required O - Miniature holder		<b>3 - Tool Type</b> VR - Internal Round shank		<b>5 - Shank front Dia</b> 0375, 050, 0625, 075, 100, 125, 150, 200, 250 6.2 (Mini Adjust) 8.0 (Mini Adjust)			<b>6 - Holder Length</b> (Mini Holders) U - Ultra Short S - Short M - Medium L - Long T - Adjustable		
<b>7 - Insert Size</b> 4.0K - IC4.0 mm 5L - IC5.0L mm 6.0 - IC6.0 mm 2 - IC1/4" 3 - IC3/8" 4 - IC1/2" 5 - IC5/8"			<b>8 - Insert style</b> U V T M Z L V6		<b>9 - Clamping</b> C - with Clamp		<b>12 - Serial No.</b> 157/... (Coarse Pitch Holder)					
			<b>10 - Oil Field</b> OIL - For API Inserts		<b>11 - RH/LH Holder</b> None - Right Hand LH - Left Hand							

## Micro & Adjustable Toolholders (Sleeves)

<b>S</b> 1	<b>M</b> 2	<b>C</b> 3	<b>0625</b> 4	<b>-</b>	<b>3</b> 5						
<b>1 - Holder Shape</b> S - Sleeve (Double Ended)		<b>2 - Holder Type</b> V - Adjustable Holders for Mini M - Micro (Double Ended)		<b>3 - Cooling</b> C - Coolant Channel		<b>4 - Holder Dia.</b> 050, 0625, 075		<b>5 - Holder Bore Size [mm]</b> Micro Size 3, 4, 6, 8, 10 Adjustable Holders (for Mini) 6.2 8			

# External Toolholders

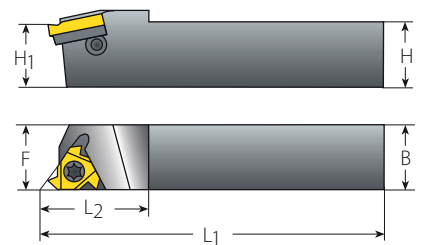
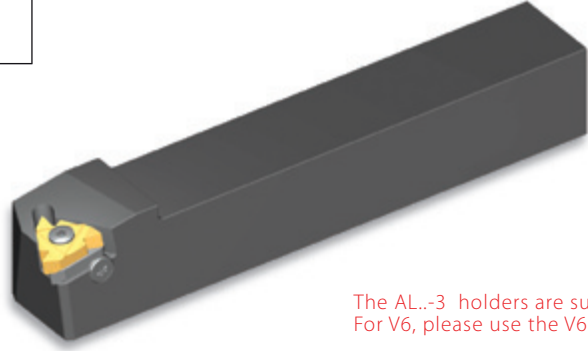
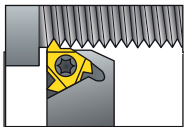

The AL..-3 holders are supplied with standard anvil (see spare parts table below). For V6, please use the V6 anvil YE3-6C. For more info see page 127.

## Standard

## Spare Parts

Insert Size	Ordering Code	EDP No.	Dimensions inch								
IC	RH		H=H1=B	F	L1	L2	Insert Screw	Anvil Screw	Torx Key	Anvil RH	Anvil LH
1/4"	NL031-2	66214	0.31	0.43	5.37	0.69	SN2T	-	K2T	-	-
	NL050-3	66220	0.50	0.63	3.27	0.87	SA3T	-	K3T	-	-
3/8"	AL3/8-3	66091	0.37	0.63	2.45	0.76	SA3T	SY3T	K3T	YE3	YI3
	AL050-3	66000	0.50	0.63	3.27	0.87					
	AL0625-3	66005	0.63	0.63	5.00	1.02					
	AL075-3	66007	0.75	0.75	5.00	1.02					
	AL100-3	66016	1.00	1.00	6.00	1.20					
	AL125-3	66036	1.25	1.25	7.00	1.18					
1/2"	AL100-4	66024	1.00	1.00	6.00	1.42	SA4T	SY4T	K4T	YE4	YI4
	AL125-4	66042	1.25	1.25	7.00	1.42					
	AL150-4	66066	1.50	1.50	8.00	1.42					
5/8"	AL100-5	66034	1.00	1.25	6.00	1.57	SA5T	SY5T	K5T	YE5	YI5
	AL125-5	66051	1.25	1.25	7.00	1.57					
	AL150-5	66073	1.50	1.50	8.00	1.57					
	AL200-5	66085	2.00	2.00	10.00	1.57					

The above toolholders have a 1.5° helix angle. For other helix angles, see page 127. Toolholders with prefix "N" cannot be used with an anvil.



## External Toolholders

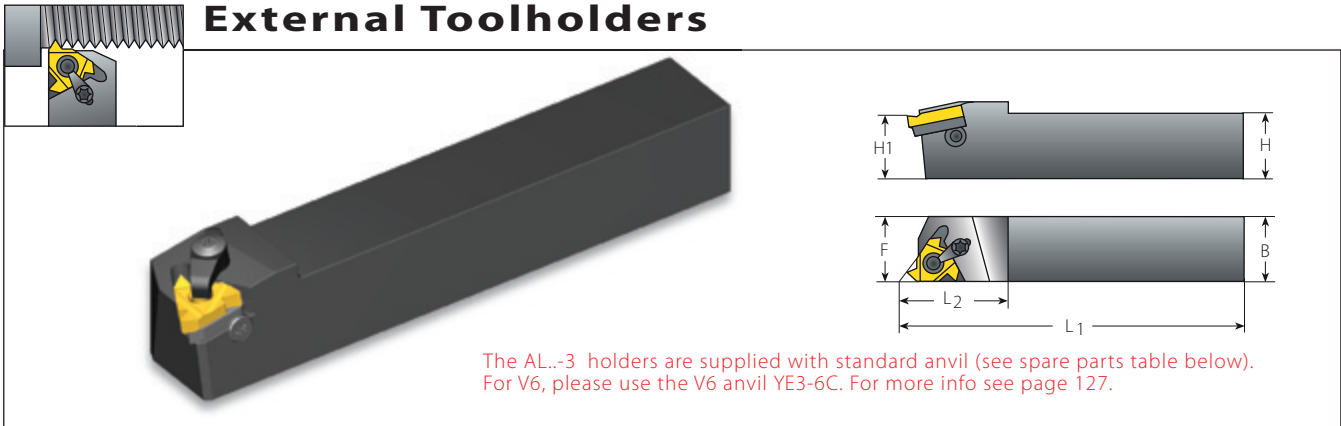

The AL..-3 holders are supplied with standard anvil (see spare parts table below). For V6, please use the V6 anvil YE3-6C. For more info see page 127.

### Standard with Clamp (Dual System, Screw or Clamp)

Insert Size	Ordering Code	EDP No.	Dimensions inch				Spare Parts					
IC	RH		H=H1=B	F	L1	L2	Insert Screw	Anvil Screw	Clamp	Torx Key	Anvil RH	Anvil LH
3/8"	AL075-3C	66008	0.75	0.75	5.00	1.20						
	AL100-3C	66017	1.00	1.00	6.00	1.20						
	AL125-3C	66031	1.25	1.25	7.00	1.20						
1/2"	AL100-4C	66330	1.00	1.00	6.00	1.42						
	AL125-4C	66222	1.25	1.25	7.00	1.42	SA4T	SY4T	C4	K4T	YE4	YI4
	AL150-4C	66223	1.50	1.50	8.00	1.42						
5/8"	AL100-5C	66327	1.00	1.25	6.00	1.57						
	AL125-5C	66224	1.25	1.25	7.00	1.57						
	AL150-5C	66225	1.50	1.50	8.00	1.57	SA5T	SY5T	C5	K5T	YE5	YI5
	AL200-5C	66230	2.00	2.00	10.00	1.57						

## External Toolholders

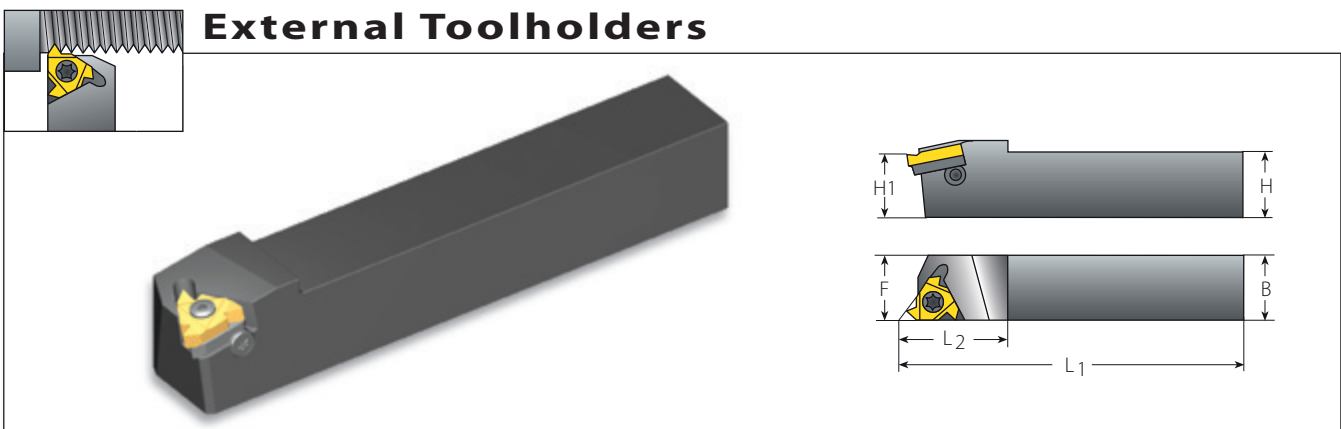

### Standard for API

Insert Size	Ordering Code	EDP No.	Thread Form	Connection no. or size	Dimensions inch			Spare Parts				
IC	RH				H=H1=B=F	L1	L2	Insert Screw	Anvil Screw	Torx Key	Anvil RH	Anvil LH
5/8"	AL125-5OIL	66058	V0.038R	V0.050 NC23-NC77 all sizes	1.25	7.00	1.60					
	AL150-5OIL	66075	V0.038R	V0.050 NC23-NC77 all sizes	1.50	8.00	1.60	SA5T	SY5T	K5T	YE5OIL	YI5OIL

## External Toolholders

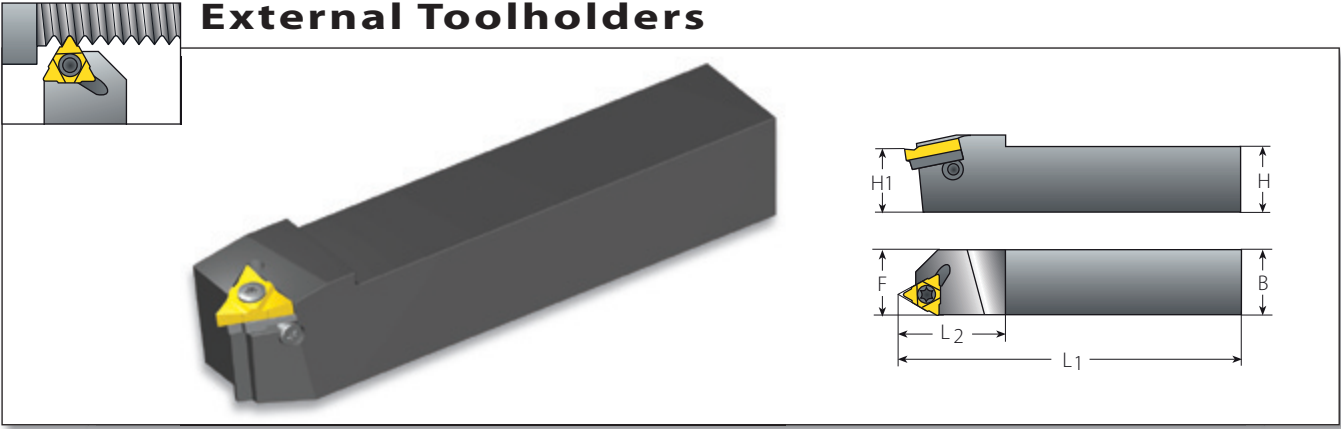

### U Style

Insert Size		Ordering Code	EDP No.	Dimensions inch			Spare Parts					
IC	RH			H=H1=B	F	L1	L2	Insert Screw	Anvil Screw	Torx Key	Anvil RH	Anvil LH
1/2"U	AL125-4U	66048		1.25	1.25	7.00	1.52	SA4T	SY4T	K4T	YE4U	YI4U
	AL150-4U	66247		1.50	1.50	8.00	1.52					
5/8"U	AL125-5U	66059		1.25	1.25	7.00	1.57					
	AL150-5U	66076		1.50	1.50	8.00	1.57	SA5T	SY5T	K5T	YE5U	YI5U
	AL200-5U	66249		2.00	2.00	10.00	1.57					

## External Toolholders

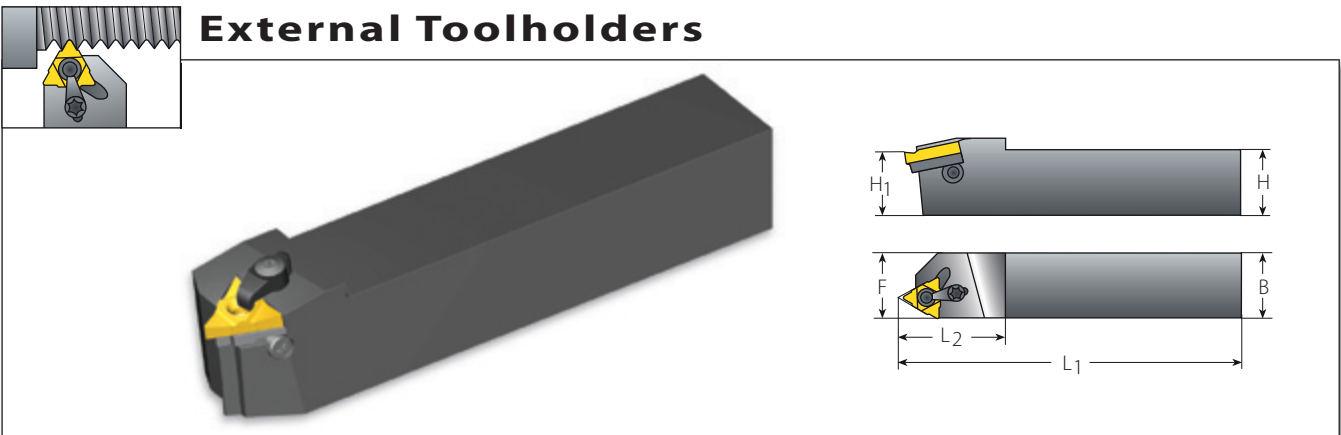

### U Style with Clamp

(Dual System, Screw or Clamp)

Insert Size		Ordering Code	EDP No.	Dimensions inch			Spare Parts						
IC	RH			H=H1=B	F	L1	L2	Insert Screw	Anvil Screw	Clamp	Torx Key	Anvil RH	Anvil LH
1/2"U	AL125-4UC	66250		1.25	1.25	7.00	1.52	SA4T	SY4T	C4	K4T	YE4U	YI4U
	AL150-4UC	66251		1.50	1.50	8.00	1.52						
5/8"U	AL125-5UC	66252		1.25	1.25	7.00	1.57						
	AL150-5UC	66253		1.50	1.50	8.00	1.57	SA5T	SY5T	C5	K5T	YE5U	YI5U
	AL200-5UC	66256		2.00	2.00	10.00	1.57						

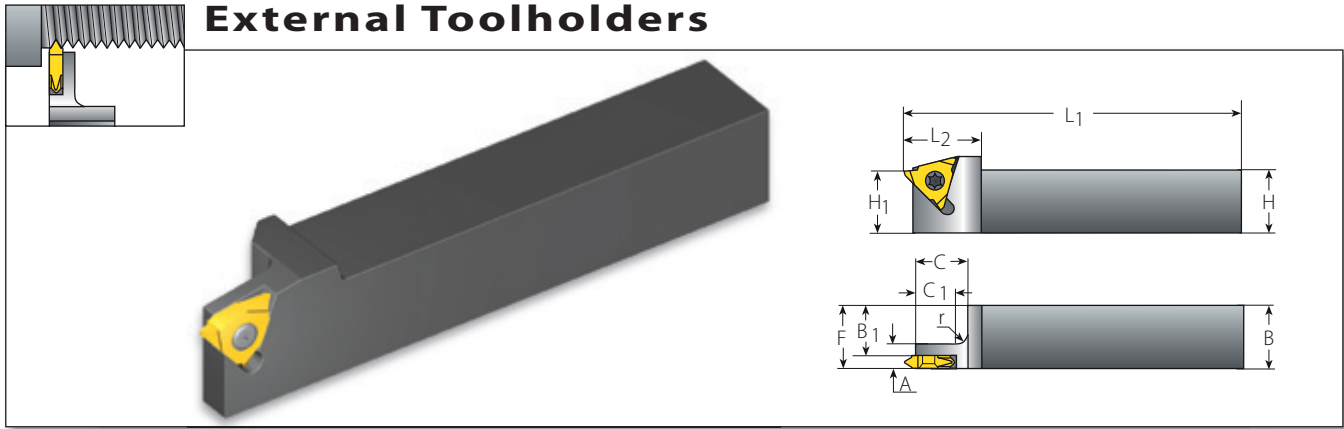

### Slim Throat

Spare Parts

Insert Size		Ordering Code		EDP No.		Dimensions inch					Spare Parts		
IC	RH		H=B=F	H1	A	B1	C	C1	L1	L2	r	Insert Screw	Torx Key
1/4"V	NL0325-2V	66257	0.27	0.32	0.25	0.25	0.50	0.45	2.50	0.60	0.04	SN2T	K2T
	NL0375-2V	67226	0.37	0.37	0.27	0.25	0.50	0.45	2.75	0.60	0.04		
	NL050-2V	67232	0.50	0.50	0.27	0.37	0.57	0.45	3.15	0.60	0.12		
	NL0625-2V	67229	0.62	0.62	0.27	0.50	0.57	0.45	4.00	0.60	0.12		
3/8"V	NL0625-3V	67201	0.62	0.62	0.27	0.47	0.57	0.45	4.00	1.00	0.12	SN3TV	K3T
	NL075-3V	67203	0.75	0.75	0.27	0.60	0.65	0.45	5.00	1.20	0.12		
	NL100-3V	67205	1.00	1.00	0.27	0.85	0.65	0.45	6.00	1.20	0.20		
	NL125-3V	66258	1.25	1.25	0.27	1.20	0.65	0.45	7.00	1.20	0.20		
1/2"V	NL150-3V	66259	1.50	1.50	0.28	1.25	0.65	0.45	8.00	1.20	0.20	SN4T	K4T
	NL100-4V	66221	1.00	1.00	0.47	0.81	0.65	0.45	6.00	1.20	0.20		
	NL125-4V	66263	1.25	1.25	0.47	1.07	0.65	0.45	7.00	1.20	0.20		
	NL150-4V	66266	1.50	1.50	0.47	1.31	0.65	0.45	8.00	1.20	0.20		

All Slim Throat toolholders have a 1.5° helix angle.

## External Toolholders

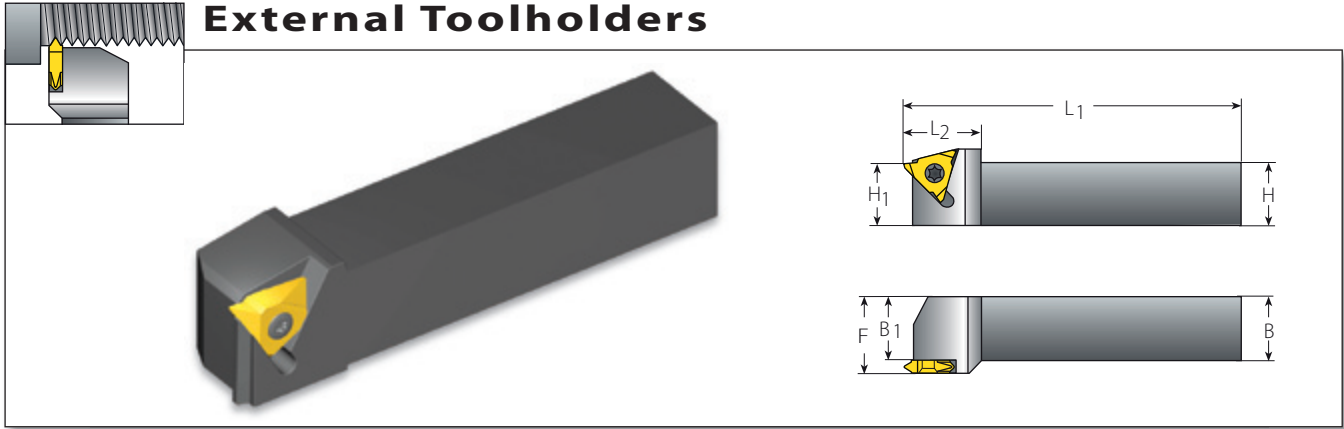

### V Style

#### Spare Parts

Insert Size		Ordering Code	EDP No.	Dimensions inch				Spare Parts	
IC	RH		H=H1=B	B1	F	L1	L2	Insert Screw	Torx key
5/8"V	NL125-5V-6	67213	1.25	1.00	1.25	7.00	1.57	SN6T	K6T
	NL125-5V-8	67214	1.25	1.00	1.33	7.00	1.57		
	NL125-5V-10	67212	1.25	1.00	1.40	7.00	1.57		
	NL125-5V-10ABUT*	66382	1.25	1.00	1.40	7.00	1.57		
	NL150-5V-6	66383	1.50	1.24	1.50	8.00	1.57		
	NL150-5V-8	66384	1.50	1.24	1.63	8.00	1.57		
	NL150-5V-10	67215	1.50	1.24	1.65	8.00	1.57		
	NL150-5V-10ABUT*	66385	1.50	1.24	1.65	8.00	1.57		

All V Style toolholders have a 1° helix angle.

The above toolholders are for RH inserts. For LH inserts, add LH to the toolholder's ordering code. (Example NL125-5V-6 **LH**)

\* To be used only with inserts 5VER2.5ABUT...

## External Toolholders

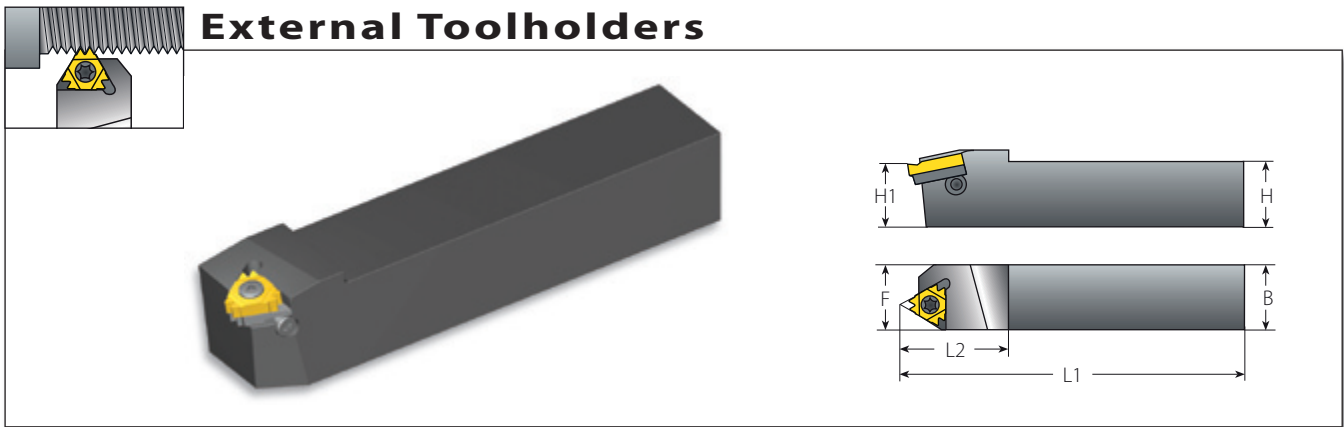

### Z+ Style

#### Spare Parts



Insert Size		Ordering Code	EDP No.	Dimensions inch			Spare Parts				
IC	RH		H=H1=B	F	L1	L2	Insert Screw	Anvil Screw	Torx Key	Anvil RH	Anvil LH
1/2"Z	AL125-4Z	66386	1.25	1.25	7.00	1.52	SA4T	SY4T	K4T	YE4Z	YI4Z
	AL150-4Z	66387	1.50	1.50	8.00	1.52					
5/8"Z	AL125-5Z	66388	1.25	1.25	7.00	1.57	SA5T	SY5T	K5T	YE5Z	YI5Z
	AL150-5Z	66389	1.50	1.50	8.00	1.57					
	AL200-5Z	66390	2.00	2.00	10.00	1.57					

All Z Style toolholders have a 1.5° helix angle.

## External Toolholders

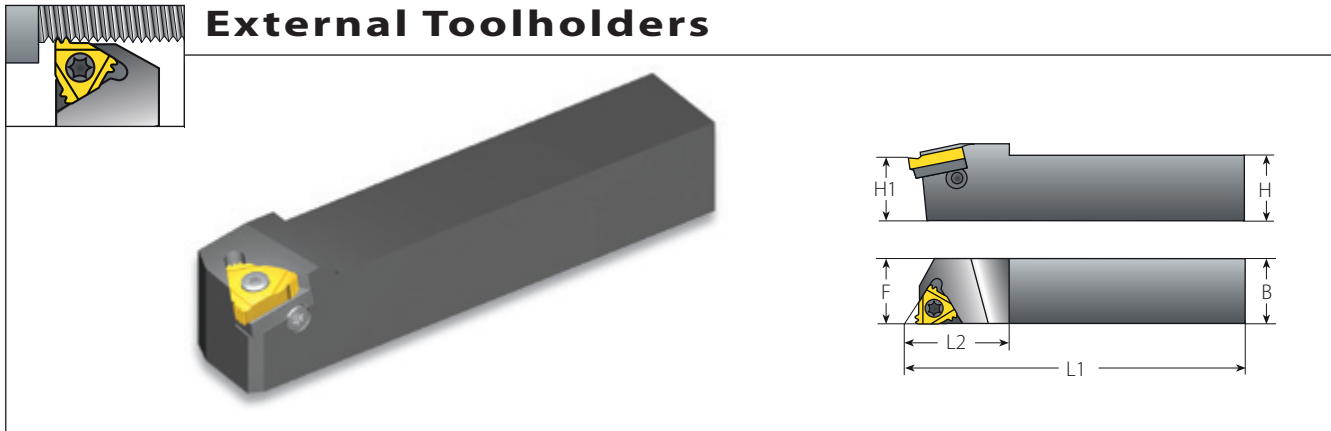

### M+ Style

Insert Size	Ordering Code	EDP No.	Dimensions inch			
IC	RH		H=H1=B	F	L1	L2
5/8"M	AL125-5M	66391	1.25	1.25	7.00	1.57
	AL150-5M	66392	1.50	1.50	8.00	1.57
	AL200-5M	66393	2.00	2.00	10.00	1.57

### Spare Parts



Insert Screw	Anvil Screw	Torx Key	Anvil RH	Anvil LH
SA5T	SY5T	K5T	YE5M	YI5M

All M Style toolholders have a 1.5° helix angle.

## External Toolholders

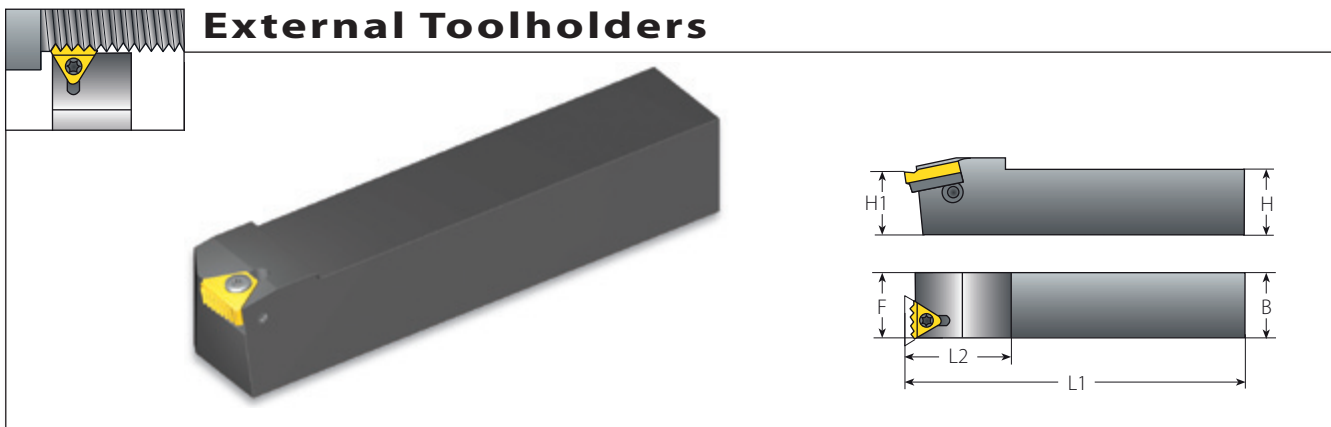

### T+ Style

Insert Size	Ordering Code	EDP No.	Dimensions inch			
IC	RH		H=H1=B	F	L1	L2
1/2"T	AL100-4T	66334	1.00	1.08	6.00	1.20
	AL125-4T	66394	1.25	1.33	7.00	1.20
	AL150-4T	66395	1.50	1.58	8.00	1.20

### Spare Parts



Insert Screw	Anvil Screw	Insert Torx Key	Anvil Torx Key	Anvil RH/LH
SA4T	SY4K2	K4T	K2	Y4T

All T Style toolholders have a 0° helix angle.

## External Toolholders

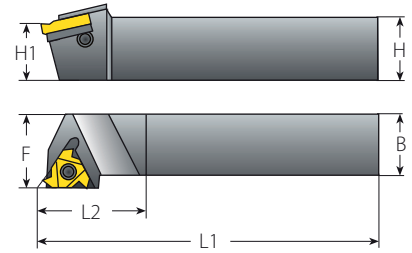
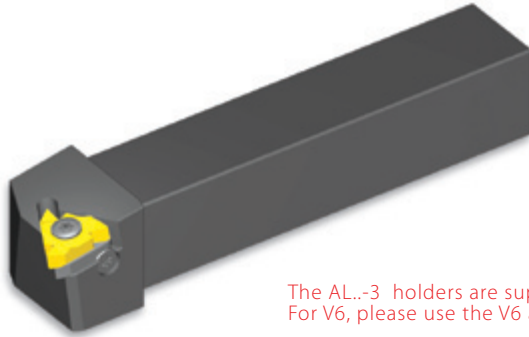
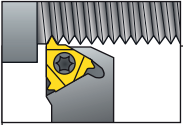

The AL..-3 holders are supplied with standard anvil (see spare parts table below). For V6, please use the V6 anvil YE3-6C. For more info see page 127.

### Off-Set Qualified (FQ)

#### Spare Parts

Insert Size	Ordering Code	EDP No.	Dimensions inch				Spare Parts				
IC	RH		H=H1=B	F	L1	L2	Insert Screw	Anvil Screw	Torx Key	Anvil RH	Anvil LH
3/8"	AL075-3FQ	66011	0.75	0.75	6.00	1.00	SA3T	SY3T	K3T	YE3	YI3
	AL100-3FQ	66020	1.00	1.25	6.00	1.00					
	AL125-3FQ	66039	1.25	1.50	6.00	1.20					
1/2"	AL100-4FQ	66027	1.00	1.25	6.00	1.20	SA4T	SY4T	K4T	YE4	YI4
	AL125-4FQ	66045	1.25	1.50	6.00	1.20					
5/8"	AL125-5FQ	66053	1.25	1.50	6.00	1.20	SA5T	SY5T	K5T	YE5	YI5

## External Toolholders

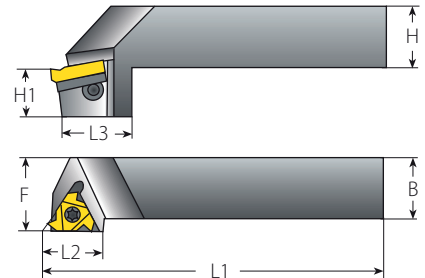
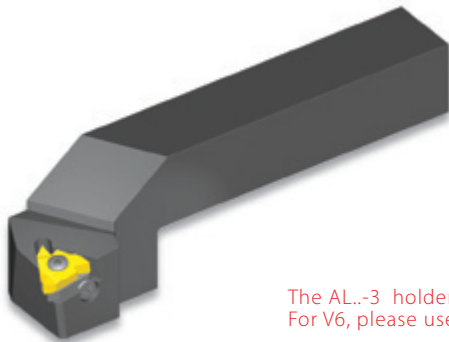

The AL..-3 holders are supplied with standard anvil (see spare parts table below). For V6, please use the V6 anvil YE3-6C. For more info see page 127.



### Drop Head-Qualified (CQ)

#### Spare Parts

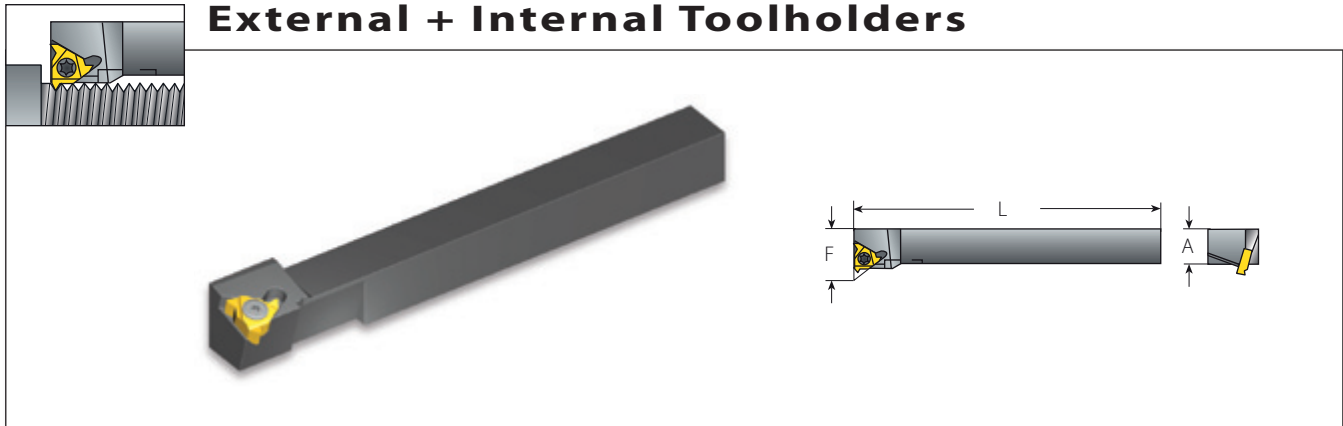
Insert Size	Ordering Code	EDP No.	Dimensions inch						Spare Parts				
IC	RH		H=B	F	L1	L2	L3	H1	Insert Screw	Anvil Screw	Torx Key	Anvil RH	Anvil LH
3/8"	AL075-3CQ	66009	0.75	1.00	5.00	0.88	1.50	0.69	SA3T	SY3T	K3T	YE3	YI3
	AL100-3CQ	66018	1.00	1.25	6.00	0.88	1.50	0.87					
	AL125-3CQ	66037	1.25	1.50	7.00	0.88	1.50	0.87					
1/2"	AL100-4CQ	66025	1.00	1.25	6.00	1.13	1.50	0.87	SA4T	SY4T	K4T	YE4	YI4
	AL125-4CQ	66043	1.25	1.50	7.00	1.13	1.50	0.87					
5/8"	AL125-5CQ	66052	1.25	1.50	7.00	1.25	1.69	1.00	SA5T	SY5T	K5T	YE5	YI5





### Miniature Square Shank\*

Miniature Square Shank*								Spare Parts	
Insert Size	Ordering Code	EDP No.	Dimensions inch				Min. Bore dia.		
IC	RH/LH		A	L	L1	F	inch	Insert Screw	Torx Key
1/4"	OV 8-2	66282	0.31	3.94	1.00	0.47	1.15	SN2T	K2T
	OV 10-2	66280	0.39	3.94	1.00	0.55	1.42		

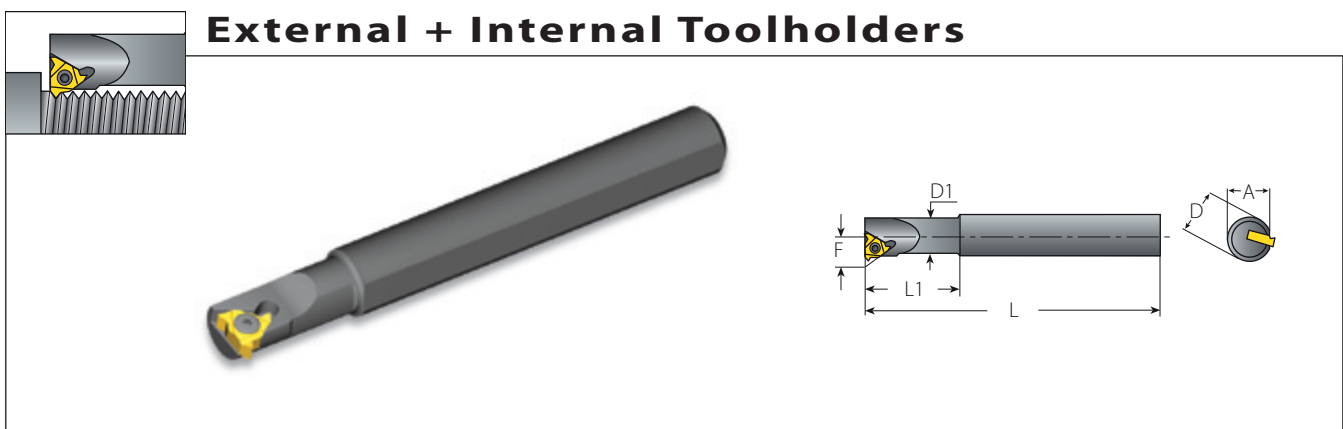
Miniature toolholders have a 0.5° helix angle.



### Miniature Round Shank\*

Miniature Round Shank*										Spare Parts		
Insert Size	Ordering Code	EDP No.	Dimensions inch							Min. Bore dia.		
IC	RH/LH		A	L	L1	D	D1	F	inch	Insert Screw	Torx Key	
1/4"	OVR 12-2	66272	0.45	3.94	0.98	0.47	0.39	0.29	0.51	SN2T	K2T	
	OVR 15-2	66274	0.56	3.94	1.26	0.59	0.51	0.35	0.63			
	OVR 16D-2	66217	0.6	3.94	1.26	0.63	0.51	0.35	0.63			

Miniature toolholders have a 0.5° helix angle.

\* Miniature square and round toolholders are designed for use on automatic lathes for the optical and other precision industries. They can be used for both external and internal threading, as follows:

Thread	ER	EL	IR	IL
Insert	ER	EL	IR	IL
Holder	LH	RH	RH	LH

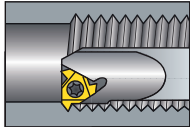



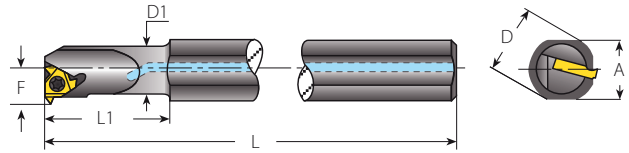
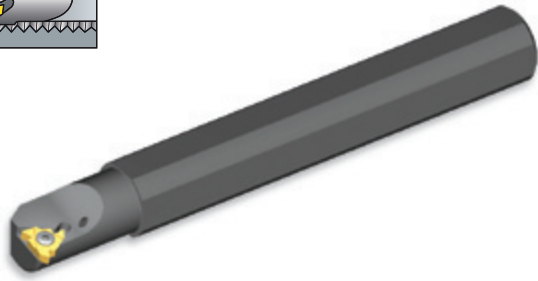

# Internal Toolholders



The AVR.-3 holders are supplied with standard anvil (see spare parts table below). For V6, please use the V6 anvil Y13-6C. For more info see page 127.

## Standard

## Spare Parts

Insert Size	Ordering Code	EDP No.	Dimensions inch							Min. Bore dia.					
IC	RH		A	L	L1	D	D1	F	inch				Anvil RH	Anvil LH	
1/4"	NVRC0375D-2	66234	0.67	7.00	1.00	0.75	0.37	0.28	0.50				-	-	
	NVRC050-2	66236	0.67	7.00	1.25	0.75	0.50	0.37	0.65	SN2T	-	K2T	-	-	
3/8"	NVRC050-3	66238	0.67	7.00	1.25	0.75	0.62	0.40	0.67	SN3T	-	K3T	-	-	
	NVRC0625-3	66240	0.67	7.00	1.50	0.75	0.62	0.46	0.80						
	NVRC0625D-3	66242	0.58	6.00	1.25	0.62	0.62	0.46	0.80						
	AVRC075-3	66098	0.67	7.00	1.50	0.75	0.75	0.51	0.90						
	AVRC100-3	66100	1.12	10.00	2.50	1.25	1.00	0.65	1.20						
	AVRC100D-3	66104	0.89	8.00	1.75	1.00	1.00	0.65	1.20	SA3T	SY3T	K3T	Y13	YE3	
	AVRC125-3	66108	1.12	10.00	2.50	1.25	1.25	0.77	1.45						
	AVRC150-3	66114	1.34	12.00	2.50	1.50	1.50	0.90	1.65						
1/2"	NVRC075-4	66244	0.67	7.00	2.00	0.75	0.75	0.59	1.00	SN4T	-	K4T	-	-	
	AVRC100-4	66102	1.12	10.00	2.50	1.25	1.00	0.71	1.25						
	AVRC100D-4	66106	0.89	8.00	1.75	1.00	1.00	0.71	1.25	SA4T	SY4T	K4T	Y14	YE4	
	AVRC125-4	66110	1.12	10.00	2.50	1.25	1.25	0.85	1.50						
5/8"	AVRC150-4	66116	1.34	12.00	2.50	1.50	1.50	0.98	1.75						
	AVRC125-5	66112	1.12	10.00	2.50	1.25	1.25	0.88	1.55	SN5T	SY5T	K5T	Y15	YE5	
	AVRC150-5	66118	1.34	12.00	2.50	1.50	1.50	1.00	1.80						
	AVRC200-5	66120	1.80	14.00	3.00	2.00	2.00	1.25	2.30	SA5T	SY5T	K5T	Y15	YE5	
	AVRC250-5	66123	2.26	16.00	3.00	2.50	2.50	1.50	2.80						

The above toolholders have a 1.5° helix angle. For other helix angles, see page 127. Toolholders with prefix "N" cannot be used with an anvil.



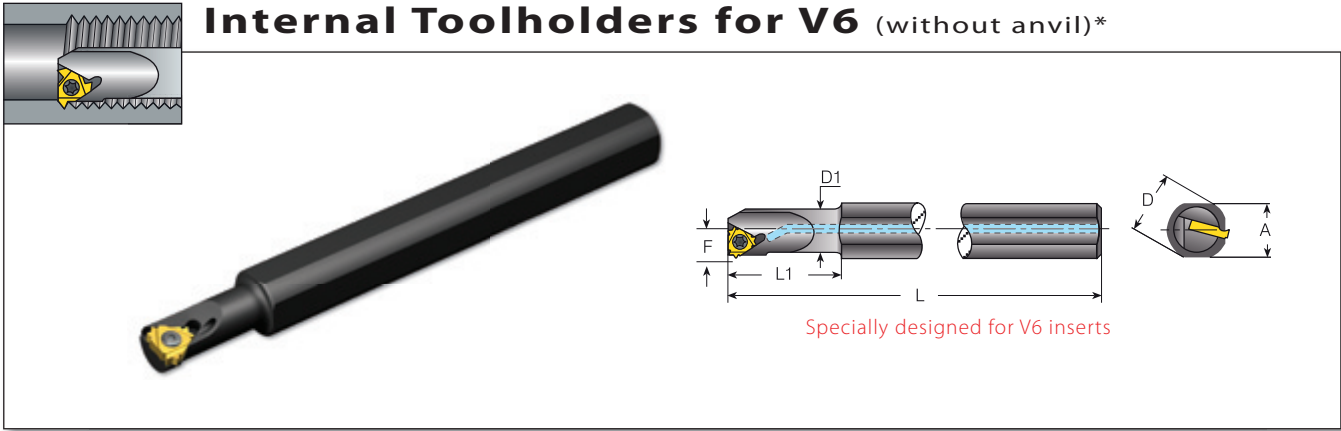

### V6 Style

Spare Parts

Insert Size	Ordering Code	EDP No.	Dimensions inch							Min. Bore dia.		
IC	RH		A	L	L1	D	D1	F	inch	Insert Screw	Torx Key	
3/8" V6	NVRC050-3V6	66231	0.67	7.0	1.25	0.75	0.50	0.40	0.67	SN3TM	K3T	
	NVRC0625-3V6	66232	0.67	7.0	1.50	0.75	0.62	0.46	0.80	SN3T		
	NVRC0625D-3V6	66233	0.58	6.0	1.25	0.62	0.62	0.46	0.80	SN3T		

The above toolholders have 1.5° helix angle.

\* V6 inserts cannot be used on standard internal toolholders without anvil. For this purpose you must use one of these special V6 toolholders.

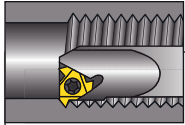

## Internal Toolholders

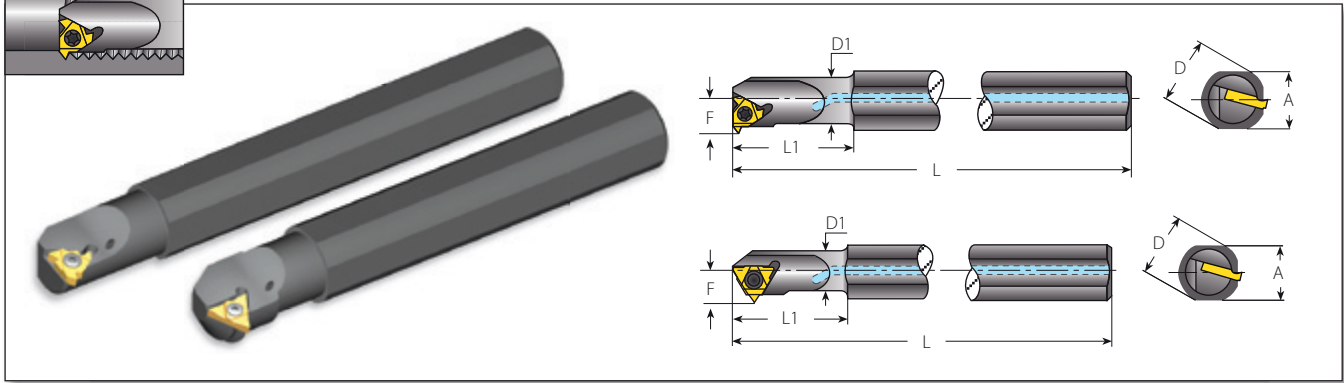

### Standard for Coarse Pitch

Insert Size	Ordering Code	EDP No.	Dimensions inch			F to insert		Holder Helix	Spare Parts			
						inch	Deg.		Insert Screw	Torx Key		
1/4"	NVRC040-2	157/001	66297	0.67	7.00	0.98	0.75	0.40	0.26	3.0	SN2T	K2T
3/8"	NVRC044-3	157/005	66301	0.67	7.00	1.00	0.75	0.44	0.33	4.5	SN3TM	K3T
	NVRC050-3	157/006	66302	0.67	7.00	1.26	0.75	0.51	0.36	4.0	SN3T	K3T
	NVRC050-3	157/016	66322	0.67	7.00	1.26	0.75	0.54	0.35	2.5		
1/2"	NVRC067-4	157/007	66303	0.67	7.00	1.57	0.75	0.66	0.45	4.0	SN4TM	K4T
	NVRC075-4	157/008	66304	0.67	7.00	1.97	0.75	0.77	0.49	3.5	SN4T	K4T
	NVRC075-4	157/009	66305	0.67	7.00	1.97	0.75	0.77	0.49	3.0		
5/8"	NVRC100-5	157/012	66362	1.12	10.00	2.36	1.25	0.98	0.66	3.3	SN5TM	K5T
	NVRC110-5	157/010	66306	1.12	10.00	1.97	1.25	1.10	0.70	3.5		

### U Style for Coarse Pitch

Insert Size	Ordering Code	EDP No.	Dimensions inch			F to insert		Holder Helix	Spare Parts			
						inch	Deg.		Insert Screw	Torx Key		
6.0U	NVRC032-6.0U	157/003	66299	0.67	7.00	0.94	0.75	0.31	0.23	4.0	SN6MT	K6MT
1/4"U	NVRC039-2U	157/004	66300	0.67	7.00	1.26	0.75	0.39	0.29	4.0	SM2T8	K2T
	NVRC044-2U	157/002	66298	0.67	7.00	1.26	0.75	0.44	0.29	3.0		
3/8"U	NVRC044-3U	157/020	66420	0.67	7.00	1.26	0.75	0.43	0.32	4.5	SN3TM	K3T
	NVRC55-3U	157/018	66396	0.67	7.00	1.50	0.75	0.53	0.39	4.5		
	NVRC59-3U	157/019	66363	0.67	7.00	1.50	0.75	0.61	0.43	4.0		
1/2"U	NVRC075-4U	157/011	66329	0.67	7.00	1.57	0.75	0.76	0.54	4.0	SN4T	K4T
	NVRC100-4U	157/013	66360	1.12	10.00	2.36	1.25	0.98	0.69	3.5		
	NVRC125-4U	157/014	66136	1.12	10.00	2.36	1.25	1.17	0.74	3.3		
5/8"U	NVRC125-5U	157/015	66361	1.12	10.00	2.36	1.25	1.24	0.83	3.2	SA5T	K5T

## Internal Toolholders

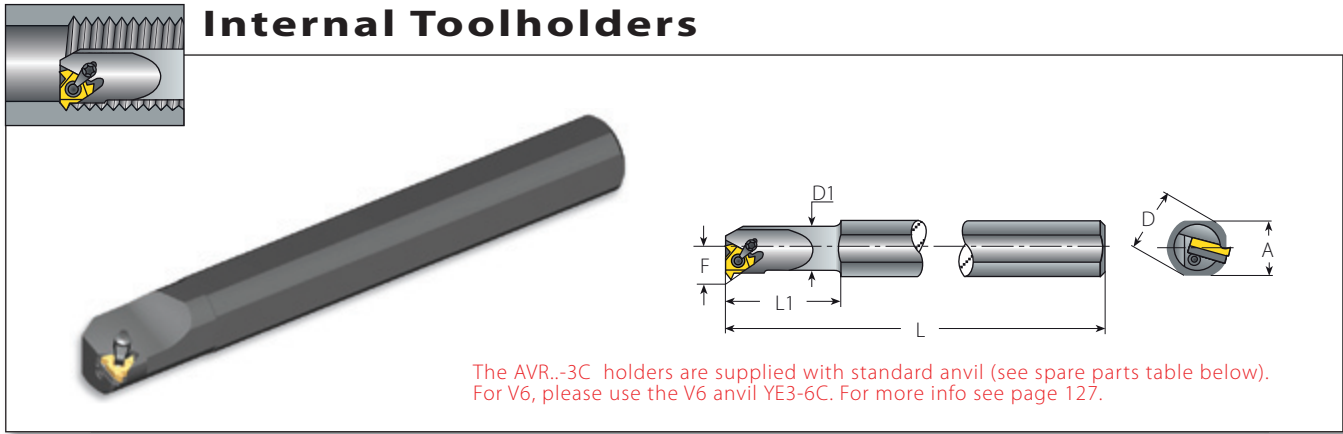

The AVR..-3C holders are supplied with standard anvil (see spare parts table below). For V6, please use the V6 anvil YE3-6C. For more info see page 127.

### Standard with Clamp

(Dual System, Screw or Clamp)

#### Spare Parts

Insert Size	Ordering Code	EDP No.	Dimensions inch							Min. Bore dia.						
			IC	RH	A	L	L1	D	D1		F	inch	Insert Screw	Anvil Screw	Clamp	Torx Key
3/8"	AVR075-3C	66130	0.67	7.00	2.00	0.75	0.75	0.51	0.94							
	AVR100-3C	66397	1.12	10.00	2.50	1.25	1.00	0.65	1.20							
	AVR100D-3C	66132	0.90	8.00	1.75	1.00	1.00	0.65	1.20	SA3T	SY3T	C3	K3CT	YI3	YE3	
	AVR125-3C	66398	1.12	10.00	2.50	1.25	1.25	0.77	1.45							
	AVR150-3C	66399	1.34	12.00	2.50	1.50	1.50	0.90	1.65							
1/2"	AVR100-4C	66400	1.12	10.00	2.50	1.25	1.00	0.71	1.25							
	AVR100D-4C	66401	0.90	8.00	1.75	1.00	1.00	0.71	1.25	SA4T	SY4T	C4	K4T	YI4	YE4	
	AVR125-4C	66402	1.12	10.00	2.50	1.25	1.25	0.85	1.50							
	AVR150-4C	66403	1.34	12.00	2.50	1.50	1.50	0.98	1.75							
5/8"	AVR125-5C	66404	1.12	10.00	2.50	1.25	1.25	0.88	1.55	SN5T	SY5T	C5	K5T	YI5	YE5	
	AVR150-5C	66405	1.34	12.00	2.50	1.50	1.50	1.00	1.80							
	AVR200-5C	66406	1.80	14.00	3.00	2.00	2.00	1.25	2.30	SA5T	SY5T	C5	K5T	YI5	YE5	
	AVR250-5C	66407	2.26	16.00	3.00	2.50	2.50	1.50	2.80							

## Internal Toolholders

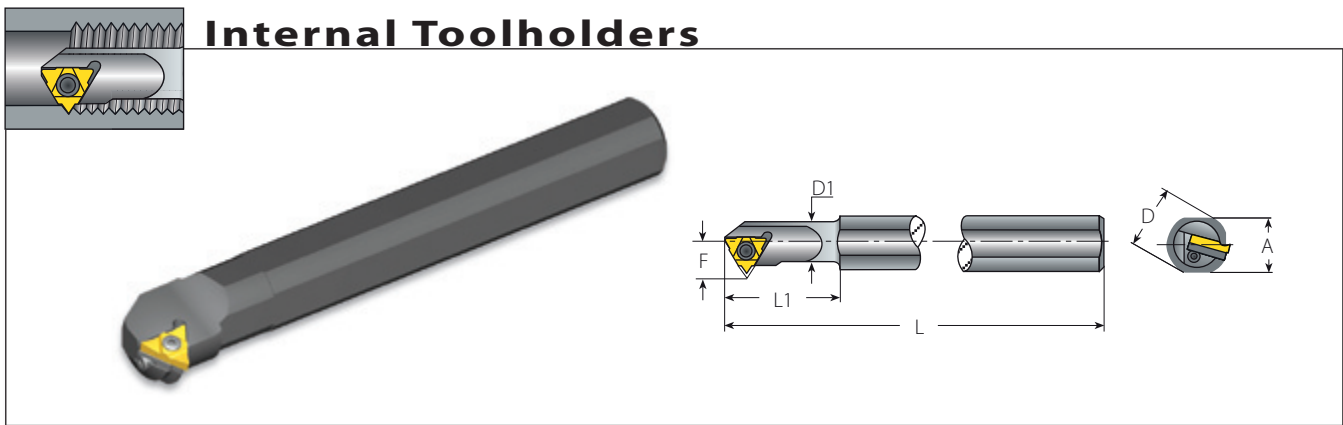

### U Style

#### Spare Parts

Insert Size	Ordering Code	EDP No.	Dimensions inch							Min. Bore dia.						
			IC	RH	A	L	L1	D	D1		F	inch	Insert Screw	Anvil Screw	Torx Key	Anvil RH
1/2"U	AVR125-4U	66421	1.12	10.00	2.50	1.25	1.25	1.01	1.65							
	AVR150-4U	66156	1.34	12.00	2.50	1.50	1.50	1.12	1.90	SA4T	SY4T	K4T	YI4U	YE4U		
5/8"U	NVR125-5U	66264	1.12	10.00	2.50	1.25	1.25	0.98	1.65	SN5T	-	K5T	-	-		
	AVR150-5U	66162	1.34	12.00	2.50	1.50	1.50	1.13	1.90							
	AVR200-5U	66179	1.80	14.00	3.00	2.00	2.00	1.37	2.40	SA5T	SY5T	K5T	YI5U	YE5U		
	AVR250-5U	66187	2.26	16.00	3.00	2.50	2.50	1.31	2.90							

The above toolholders have a 1.5° helix angle. For other helix angles, see page 127. Toolholders with prefix "N" cannot be used with an anvil. Holders with coolant channel available as standard. (Example AVR100-3C).

The above toolholders are for RH inserts. For LH inserts, add LH to the toolholder's ordering code. (Example AVR075-3C LH)

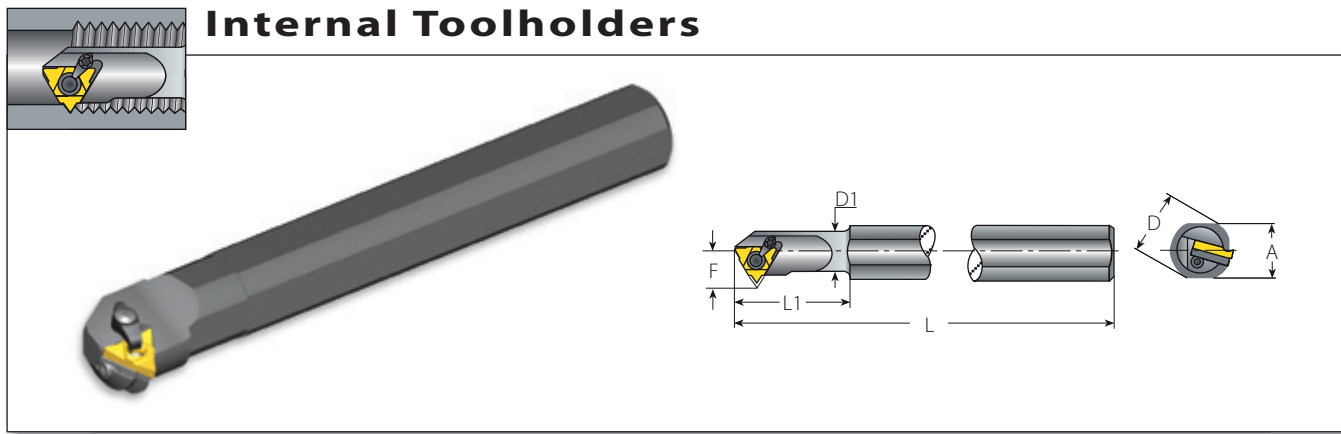

### U style with Clamp

(Dual System, Screw or Clamp)

Insert Size	Ordering Code	EDP No.	Dimensions inch							Min. Bore dia.	Spare Parts					
			IC	RH	A	L	L1	D	D1		F	inch	Insert Screw	Anvil Screw	Clamp	Torx Key
1/2"U	AVR125-4UC	66408	1.12	10.00	2.50	1.25	1.25	1.01	1.65	SA4T	SY4T	C4	K4T	YI4U	YE4U	
	AVR150-4UC	66409	1.34	12.00	2.50	1.50	1.50	1.12	1.90							
5/8"U	AVR150-5UC	66410	1.34	12.00	2.50	1.50	1.50	1.13	1.90							
	AVR200-5UC	66411	1.80	14.00	3.00	2.00	2.00	1.37	2.40	SA5T	SY5T	C5	K5T	YI5U	YE5U	
	AVR250-5UC	66412	2.26	16.00	3.00	2.50	2.50	1.61	2.90							

The above toolholders have a 1.5° helix angle. For other helix angles, see page 127.

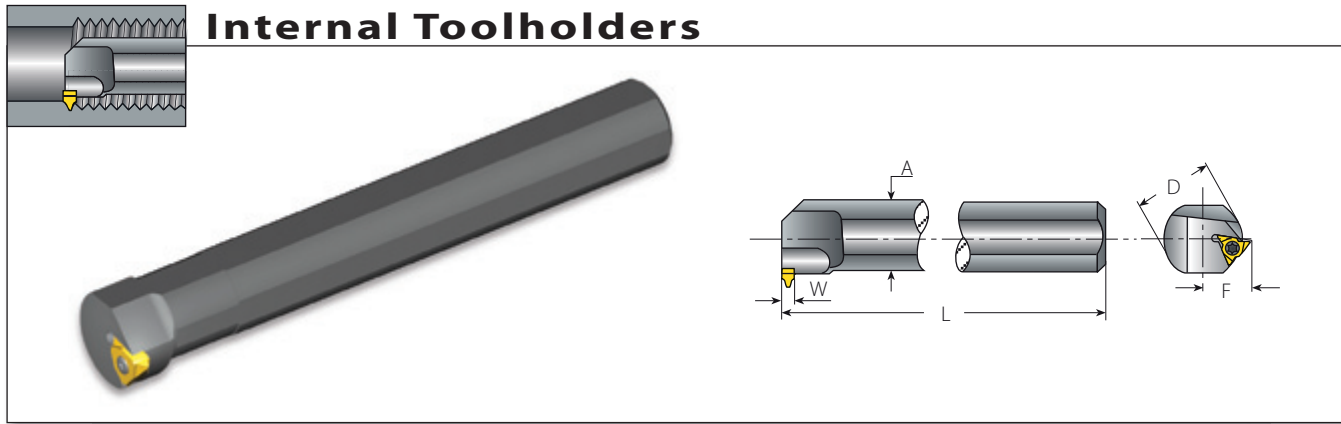

### V Style

Insert Size	Ordering Code	EDP No.	Dimensions inch					Spare Parts		
			IC	RH	A	L	D	F	W	Insert Screw
5/8"V	NVR150-5V	67220		1.34	12.00	1.50	1.08	0.256		
	NVR200-5V	67222		1.80	14.00	2.00	1.33	0.256	SN6T	K6T
	NVR250-5V	67223		2.26	16.00	2.50	1.58	0.256		

The above toolholders have a 1.0° helix angle.

### Minimum Bore Dia

	Pitch mm	6.0 ISO	8.0 ISO	10.0 ISO	
	Pitch tpi	4 UN	3 UN		2.5 W
NVR150-5V		1.98	2.17	2.76	3.15
NVR200-5V		2.37	2.37	2.76	3.15
NVR250-5V		2.76	2.76	2.76	3.15

## Internal Toolholders

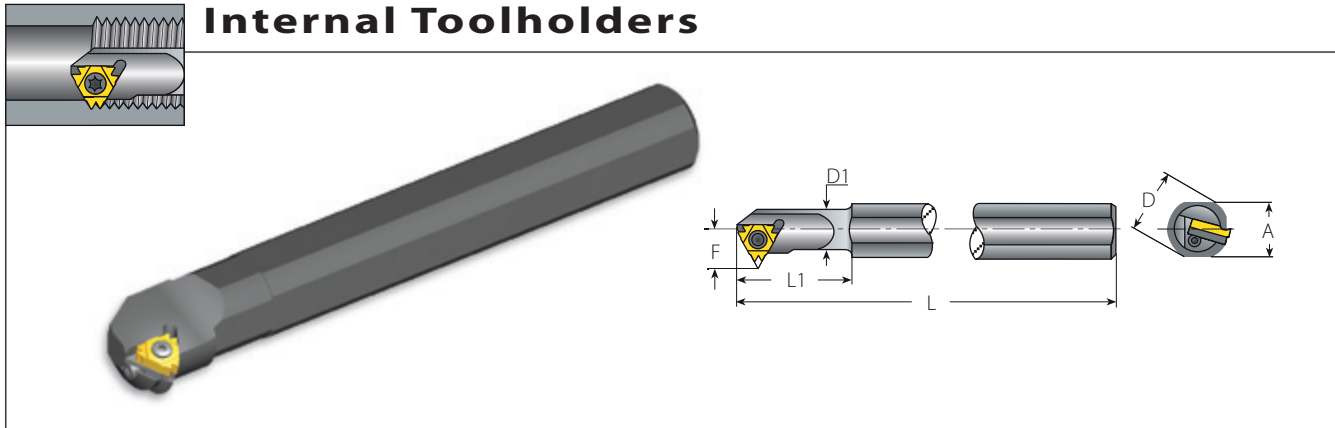

### Z+ Style

Insert Size		Ordering Code	EDP No.	Dimensions inch						Min. Bore dia.	Spare Parts				
IC	RH			A	L	L1	D	D1	F	inch	Insert Screw	Anvil Screw	Torx Key	Anvil RH	Anvil LH
1/2"Z	AVR125-4Z	66413		1.12	10.00	2.50	1.25	1.25	1.01	1.65	SA4T	SY4T	K4T	YI4Z	YE4Z
	AVR150-4Z	66414		1.34	12.00	2.50	1.50	1.50	1.12	1.90					
5/8"Z	NVR125-5Z	66415		1.12	10.00	2.50	1.25	1.25	0.98	1.65	SN5T	-	K5T	-	-
	AVR150-5Z	66416		1.34	12.00	2.50	1.50	1.50	1.13	1.90					
	AVR200-5Z	66417		1.80	14.00	3.00	2.00	2.00	1.37	2.40	SA5T	SY5T	K5T	YI5Z	YE5Z
	AVR250-5Z	66418		2.26	16.00	3.00	2.50	2.50	1.61	2.90					

All Z style toolholders have a 1.5° helix angle.

## Internal Toolholders

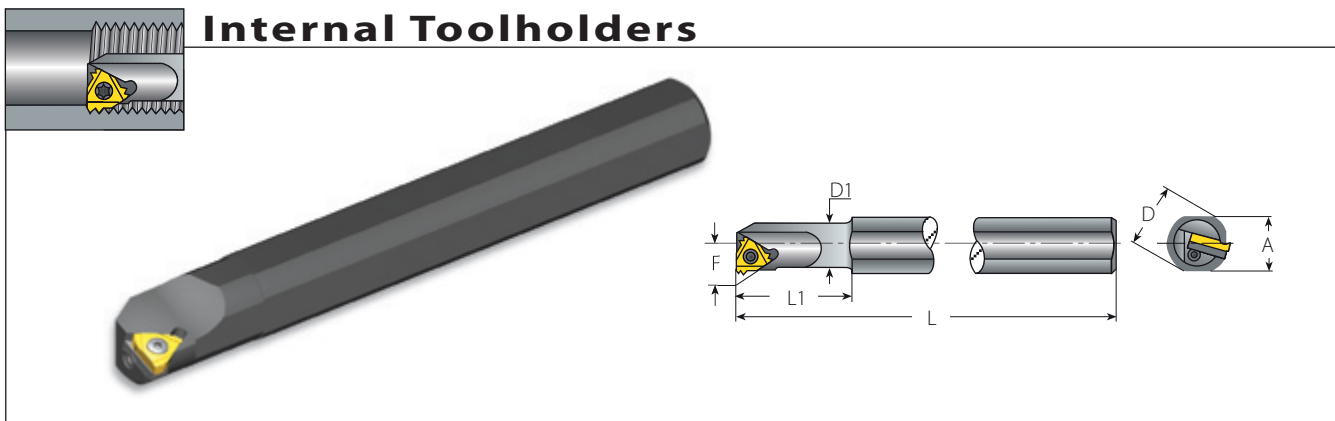

### M+ Style

Insert Size		Ordering Code	EDP No.	Dimensions inch						Min. Bore dia.	Spare Parts				
IC	RH			A	L	L1	D	D1	F	inch	Insert Screw	Anvil Screw	Torx Key	Anvil RH	Anvil LH
5/8"M	AVR125-5M	66127		1.12	10.00	2.50	1.25	1.25	0.88	1.55	SN5T	SY5T	K5T	YI5M	YE5M
	AVR150-5M	66161		1.34	12.00	2.50	1.50	1.50	1.00	1.80					
	AVR200-5M	66419		1.80	14.00	3.00	2.00	2.00	1.25	2.30	SA5T	SY5T	K5T	YI5M	YE5M
	AVR250-5M	66422		2.26	16.00	3.00	2.50	2.50	1.50	2.80					

All M style toolholders have a 1.5° helix angle.

## Internal Toolholders

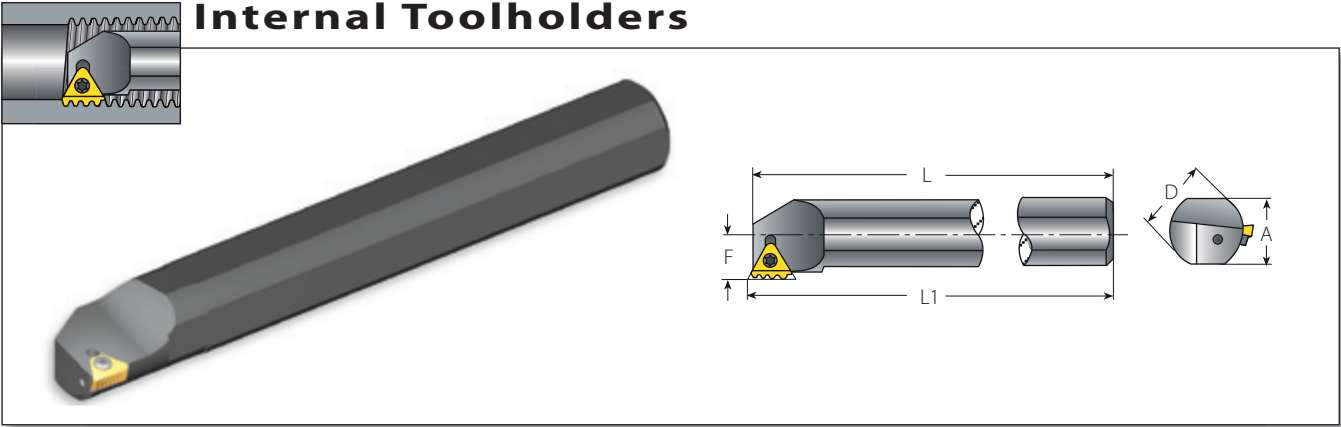

### T+ Style

Spare Parts **Multiplus**

Insert Size	Ordering Code	EDP No.	Dimensions inch					Min. Bore dia.	Spare Parts				
IC	RH		A	L	L1	D	F	inch	Insert Screw	Anvil Screw	Torx Key	Anvil Torx Key	Anvil RH/LH
1/2" T	AVR150-4T	66423	1.34	12.00	12.08	1.50	0.88	2.40	SA4T	SY4K2	K4T	K2	Y4T
	AVR200-4T	66424	1.80	14.00	14.08	2.00	1.13	2.75					
	AVR250-4T	66425	2.26	16.00	16.08	2.50	1.38	3.25					

All toolholders have a 0° helix angle.  
 Holders with coolant channel available as standard. (Example: AVRC150-4T)

## Internal Toolholders

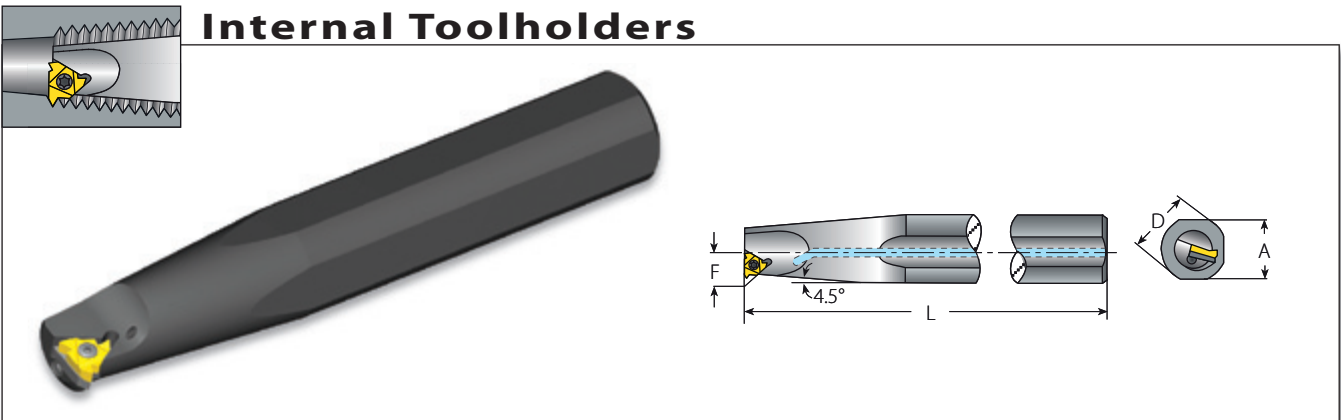

### API

Spare Parts

Insert Size	Ordering Code	EDP No.	Thread Form	Connection no. or size	Dimensions inch				Spare Parts				
IC	RH				A	L	D	F	Insert Screw	Anvil Screw	Torx Key	Anvil RH	Anvil LH
5/8"	AVR200-5OIL	66426	V0.038R	NC23-NC38	1.80	12.0	2.00	0.90	SA5T	SY5T	K5T	Y15OIL	YE5OIL
	AVRC200-5OIL	66122	V0.038R	NC23-NC38									
	AVR300-5OIL	66188	V0.050R	NC40-NC77	2.68	16.0	3.00	1.50					
	AVRC300-5OIL	66125	V0.050R	NC40-NC77									

The above toolholders have a 1.5° helix angle.  
 Toolholders ordered with an internal coolant channel have an internal BSP 1/2" thread for connection to the flexible coolant pipe.  
 The above toolholders are for RH inserts. For LH inserts, add LH to the toolholder's ordering code. (Example AVR200-5OIL LH)

# Internal Toolholders

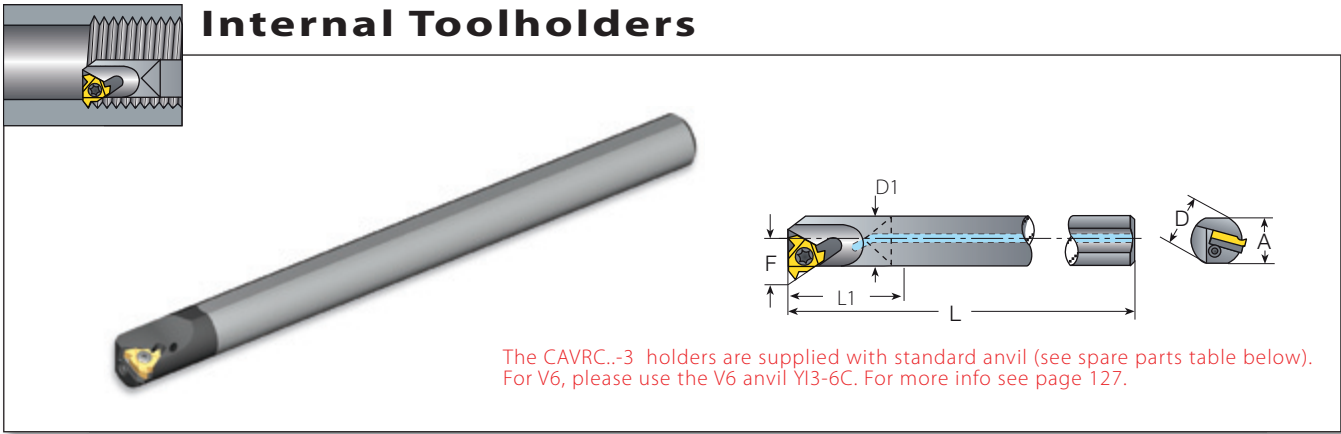

## Standard with Carbide Shank

Standard with Carbide Shank										Spare Parts					
Insert Size	Ordering Code	EDP No.	Dimensions inch							Min. Bore dia.					
IC	RH		A	L	L1	D	D1	F	inch				Anvil RH	Anvil LH	
4.0 mm	CNVRC0205-4.0K	66347	0.20	4.00	1.02	0.25	0.20	0.17	0.24	SN4MT	-	K6MT	-	-	
1/4"	CNVRC0375-2	66196	0.35	6.00	-	0.37	0.37	0.28	0.50	SN2T	-	K2T	-	-	
	CNVRC050-2	66197	0.48	7.00	-	0.50	0.50	0.35	0.60						
3/8"	CNVRC050-3	66199	0.48	7.00	-	0.50	0.50	0.40	0.67	SN3T	-	K3T	-	-	
	CNVRC0625-3	66200	0.60	8.00	-	0.62	0.62	0.45	0.80						
	CAVRC075-3	66194	0.73	10.00	-	0.75	0.75	0.51	0.90						SA3T
1/2"	CNVRC075-4	66202	0.73	10.00	-	0.75	0.75	0.59	1.00	SN4T	-	K4T	-	-	

The above toolholders have 1.5° helix angle. For other helix angles see page 127.  
 Toolholders with prefix "CN" cannot be used with an anvil. The above Toolholders have coolant channel as standard.

Carbide Shank toolholders should be used when extra accuracy is required or when the bar length to bar diameter ratio exceeds 3:1.

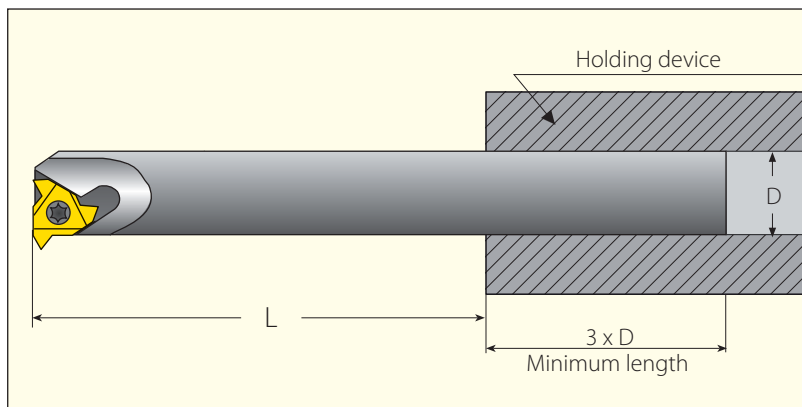

The overhang to bar diameter ratio should be as small as possible to eliminate the chance of chatter (vibration). The minimum length inside a holding device should be 3 times the diameter of the bar shank.

## Internal Toolholders

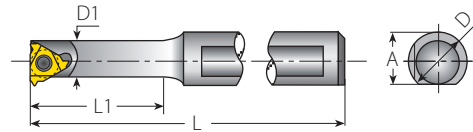
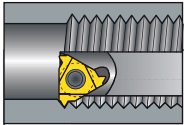

### Mini-3

#### Spare Parts

Insert Size	Ordering Code	EDP No.	Dimensions inch					Anti-Vibration System		
IC mm	RH		A	L	L1	D	D1		Insert Screw	Torx Key
4.0	SNVR 0205-4.0K	42267	0.46	4.00	0.47	0.50	0.20	No	SN4MT	K6MT
	SNVR 375U-6.0	67338	0.36	3.23	0.63	0.37	0.31	No	SN6MT	K6MT
6.0	BNVR 375S-6.0	67308	0.36	3.50	0.87	0.37	0.31	Carbide Implanted		
	BNVR 375M-6.0	67304	0.36	3.86	1.22	0.37	0.31	Carbide Implanted		
	BNVR 375L-6.0	67301	0.36	4.33	1.69	0.37	0.31	Carbide Implanted		
6.0	SNVR 050U-6.0	67341	0.49	3.23	0.63	0.50	0.31	No		
	BNVR 050S-6.0	67317	0.49	3.50	0.87	0.50	0.31	Carbide Implanted		
	BNVR 050M-6.0	67313	0.49	3.86	1.22	0.50	0.31	Carbide Implanted		
	BNVR 050L-6.0	67310	0.49	4.33	1.69	0.50	0.31	Carbide Implanted		

## Internal Toolholders

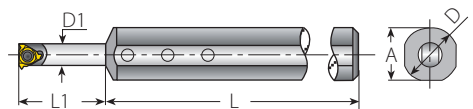
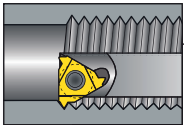

### Mini-3 Adjustable

#### Spare Parts

Insert Size	Ordering Code	EDP No.	Ordering Code	EDP No.	Dimensions inch								
IC mm	Sleeve		Holder		A	L	L1	D	D1	Insert Screw	Torx Key for Insert Screw	Holder Screw x3	Key for Holder Screw
6.0	SV0625-8.0	67344	BNVR8.0T-6.0	67326	.584	4	0.315-2.2	.625	.315	SN6MT	K6MT	S4.0	K2.0



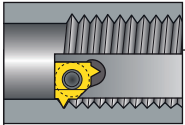

## Internal Toolholders

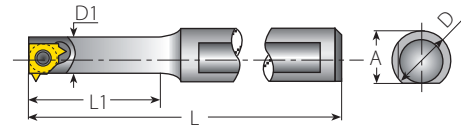

### Mini-L

Mini-L									Spare Parts	
Insert Size	Ordering Code	EDP No.	Dimensions inch					Anti-Vibration System		
IC	RH		A	L	L1	D	D1		Insert Screw	Torx Key
5.0L	SNVR 0375U-5L	67336	0.36	3.19	0.63	0.37	0.24	No	SN5LT	K5LT
	BNVR 0375S-5L	67306	0.36	3.43	0.87	0.37	0.24	Carbide Implanted		
	BNVR 0375M-5L	67302	0.36	3.82	1.22	0.37	0.24	Carbide Implanted		
	BNVR 0375L-5L	67300	0.36	4.29	1.69	0.37	0.24	Carbide Implanted		
5.0L	SNVR 050U-5L	67340	0.49	3.19	0.63	0.50	0.24	No		
	BNVR 050S-5L	67315	0.49	3.43	0.87	0.50	0.24	Carbide Implanted		
	BNVR 050M-5L	67311	0.49	3.82	1.22	0.50	0.24	Carbide Implanted		
	BNVR 050L-5L	67309	0.49	4.29	1.69	0.50	0.24	Carbide Implanted		

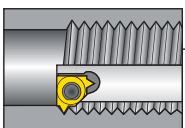

## Internal Toolholders

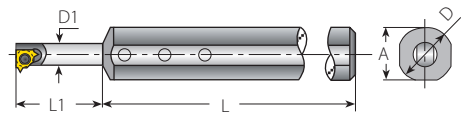
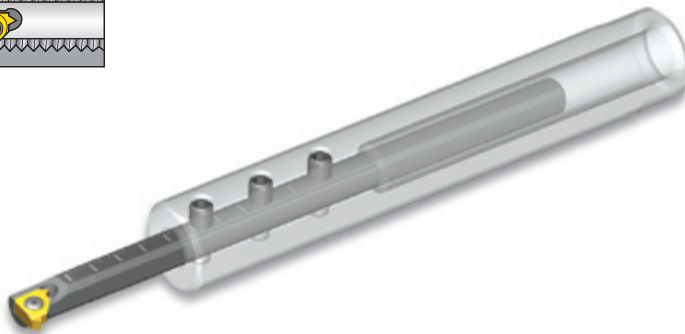

### Mini-L-Adjustable

Mini-L-Adjustable							Spare Parts			
Insert Size	Ordering Code	EDP No.	Ordering Code	EDP No.	Dimensions inch					
IC mm	Sleeve		Holder		A	L L1 D D1	Insert Screw	Torx Key for Insert Screw	Holder Screw x3	Key for Holder Screw
5.0L	SV0625-6.2	67343	BNVR6.2T-5L	67324	.584	4 0.315-1.73 .625 .244	SN5LT	K5LT	S4.0	K2.0

# Internal Toolholders



Thread Turning Toolholders

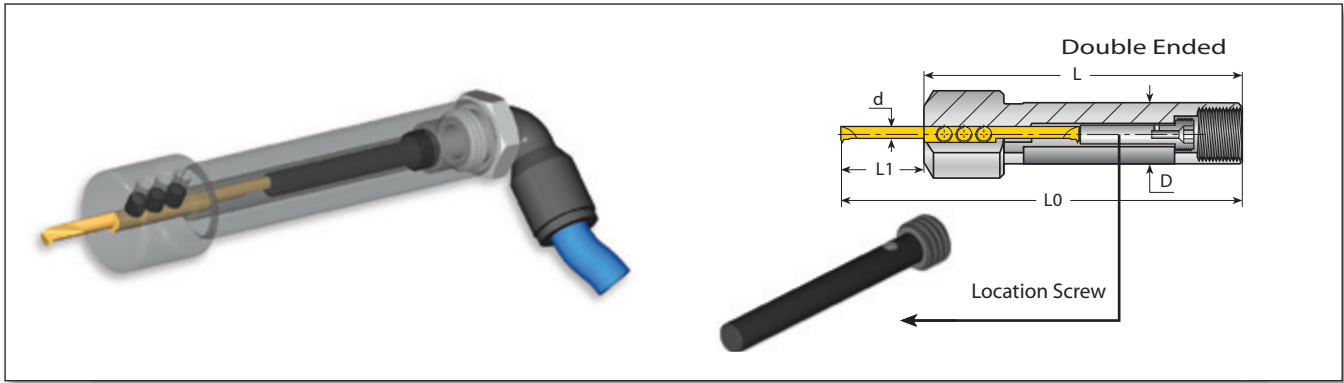

### Spare Parts



### Micro - Double Ended

Micro Insert Dia.	Shank Dia.	Ordering Code	EDP No.	Dimensions inch			Location Screw*			Clamping Screw x 3				
				d [mm]	D	L	L1	L0	Screw	M	Key	Screw	Key	
3	0.50	SMC050-3.0	41075	3.15	0.35- Short	3.50	4GISM8X28	1.10	K4.0	M4X0.7X4.0	K2.0			
					0.63- Medium							3.78	4GISM8X21	0.83
	3.74	0.35- Short	4.09	4GISM8X49	1.93									
		0.63- Medium	4.37	4GISM8X42	1.65									
4	0.50	SMC050-4.0	41092	3.15	0.35- Short	3.50	4GISM8X28	1.10						
					0.63- Medium							3.78	4GISM8X21	0.83
					0.83- Long							3.98	4GISM8X16	0.63
	3.74	0.35- Short	4.09	4GISM8X49	1.93									
		0.63- Medium	4.37	4GISM8X42	1.65									
		0.83- Long	4.57	4GISM8X37	1.46									
6	0.50	SMC050-6.0	41517	3.15	0.35- Short	3.50	4GISM8X28	1.10						
					0.63- Medium				3.78	4GISM8X21	0.83			
					0.83- Long				3.98	4GISM8X16	0.63			
	3.74	0.35- Short	4.09	4GISM8X49	1.93									
		0.63- Medium	4.37	4GISM8X42	1.65									
		0.83- Long	4.57	4GISM8X37	1.46									

\* Every toolholder package contains the full range of location screws needed.

# Spare Parts

## External and Internal Toolholders (not including Micro)



Toolholder	IC	Designation	Thread	Designation	Thread	Key	EX RH / IN LH	IN RH / EX LH
Standard	1/4"	SN2T	M2.6x0.45x6.5	-	-	K2T	-	-
	3/8", 3/8"V6*	SA3T	UNC5x12.0	SY3T	UNC5x7.3	K3T	YE3/YE3-6C	YI3/YI3-6C
	1/2"***	SA4T	UNC8x15.2	SY4T	UNC8x9.3	K4T	YE4	YI4
	5/8"	SA5T	M5x0.8x22.0	SY5T	M5x0.8x9.5	K5T	YE5	YI5
Standard with clamp	3/8"	SA3T/C3	UNC5x12.0/M5x0.8x22.0	SY3T	UNC5x7.3	K3CT	YE3	YI3
	1/2"	SA4T/C4	UNC8x15.2/M6x1.0x29.5	SY4T	UNC8x9.3	K4T	YE4	YI4
	5/8"	SA5T/C5	M5x0.8x22.0/M8x1.25x28.0	SY5T	M5x0.8x9.5	K5T	YE5	YI5
U Style	1/2"U	SA4T	UNC8x15.2	SY4T	UNC8x9.3	K4T	YE4U	YI4U
	5/8"U	SA5T	M5x0.8x22.0	SY5T	M5x0.8x9.5	K5T	YE5U	YI5U
U Style with clamp	1/2"	SA4T/C4	UNC8x15.2/M6x1.0x29.5	SY4T	UNC8x9.3	K4T	YE4U	YI4U
	5/8"	SA5T/C5	M5x0.8x22.0/M8x1.25x28.0	SY5T	M5x0.8x9.5	K5T	YE5U	YI5U
V Style	1/4"V	SN2T	M2.6x0.45x6.5	-	-	K2T	-	-
	3/8"V	SN3TV	UNC5x7.5	-	-	K3T	-	-
	1/2"V	SN4T	UNC8x15.2	-	-	K4T	-	-
	5/8"V	SN6T	M6x1.0x29.5	-	-	K6T	-	-
Z+ Style	1/2"Z	SA4T	UNC8x15.2	SY4T	UNC8x9.3	K4T	YE4Z	YI4Z
	5/8"Z	SA5T	M5x0.8x22.0	SY5T	M5x0.8x9.5	K5T	YE5Z	YI5Z
M+ Style	3/8"M	SA3T	UNC5x12.0	SY3T	UNC5x7.3	K3T	YE3M	YI3M
	1/2"M	SA4T	UNC8x15.2	SY4T	UNC8x9.3	K4T	YE4M	YI4M
	5/8"M	SA5T	M5x0.8x22.0	SY5T	M5x0.8x9.5	K5T	YE5M	YI5M
T+ Style	1/2"T	SA4T	UNC8x15.2	SY4K2	UNC8x7.3	K4T/K2	Y4T	Y4T
API	5/8"	SA5T/C5	M5x0.8x22.0/M8x1.25x28.0	SY5T	M5x0.8x9.5	K5T	YE5OIL	YI5OIL
Mini-L	5.0L	SN5LT	M2x0.4x4.1	-	-	K5LT	-	-
Mini-3	4.0mm	SN4MT	M2x0.4x4.0	-	-	K6MT	-	-
	6.0mm	SN6MT	M1.8x0.35x4.5	-	-	K6MT	-	-
Mini Adjustable Holder	-	S4.0	M4x0.7x4.0	-	-	K2.0	-	-

\* NVR0625-3 requires insert screw SN3T (UNC5x9.5) \*\* NVR075-4 requires insert screw SN4T (UNC8x12.0)  
SN5T (M5x0.8x18) for holders A/NVR125-5...

For Micro Toolholders see page 118.





# Thread Turning

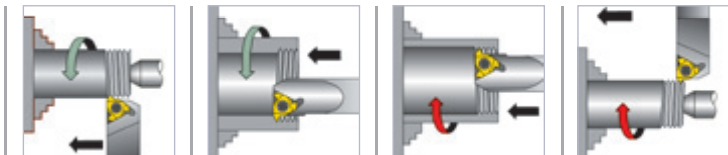

> **Technical Data**

# THREAD TURNING TECHNICAL DATA

■ Thread Terminology .....	Page 123
■ Machining a Multi-Start Thread .....	Page 124
■ Insert Profile Styles .....	Page 124
■ Thread Turning Methods .....	Page 125
■ Thread Infeed Methods .....	Page 125
■ Calculating the Helix Angle and Choosing the Right Anvil .....	Page 126
■ Anvils and Anvil Kits .....	Page 127
■ Grades and Their Applications .....	Page 128
■ Recommended Grades and Cutting Speeds - (not including Mini and Micro) .....	Page 129
■ Recommended Grades and Cutting Speeds - (Mini and Micro) .....	Page 130
■ Number of Passes .....	Page 131
■ Cutting Conditions Depends On... ..	Page 131
■ Radial infeed per pass .....	Page 132
■ Number of Passes and Depth of Cut per Pass for Multi+ Inserts .....	Page 138
■ Step by Step Thread Turning - Examples .....	Page 140
■ Material Comparison Table .....	Page 144
■ Troubleshooting .....	Page 148

# Thread Terminology

## External Thread

A thread on the external surface of a cylinder screw or cone

## Depth of Thread

The distance between crest and root measured normal to the axis.

## Pitch

The distance between corresponding points on adjacent thread forms measured parallel to the axis. This distance can be defined in millimeters or by the tpi (threads per inch), which is the reciprocal of the pitch.

## Nominal Diameter

The diameter from which the diameter limits are derived by the application of deviation allowances and tolerances.

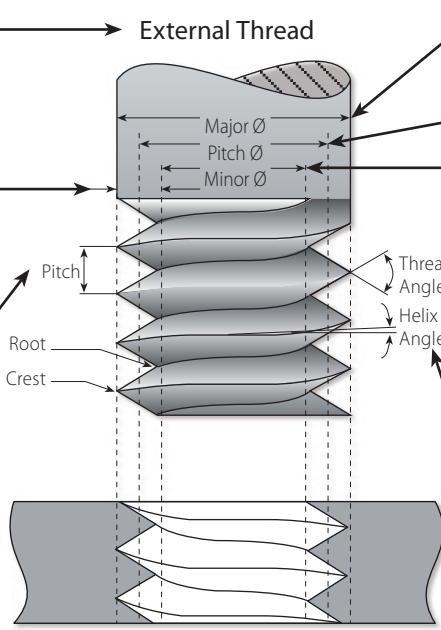

## Internal Thread

A thread on the internal surface of a cylinder or cone.

## Major Diameter

The largest diameter of a screw thread.

## Pitch Diameter

On a straight thread, the diameter of an imaginary cylinder, the surface of which cuts the thread forms where the width of the thread and groove are equal.

## Minor Diameter

The smallest diameter of a screw thread.

## Helix Angle

For a straight thread, where the lead of the thread and the pitch diameter circle circumference form a right angled triangle, the helix angle is the angle opposite the lead.

## Straight Thread

A thread formed on a cylinder

## Taper Thread

A thread formed on a cone

## Left-hand thread

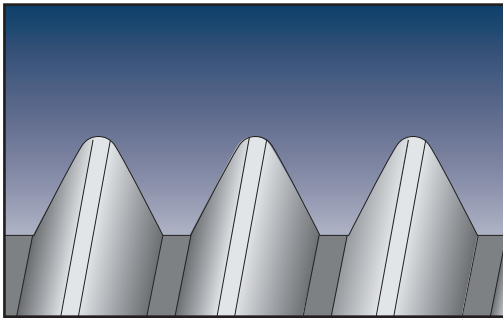

A thread which, when viewed axially, winds in a counterclockwise and receding direction. All left-hand threads are designated LH.

## Right-hand thread

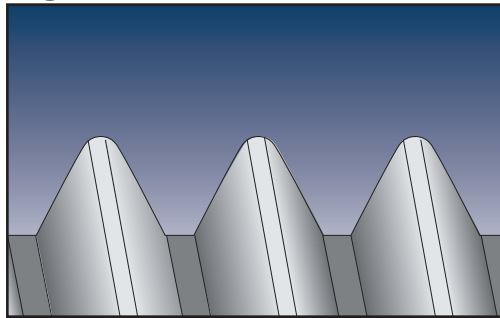

A thread which, when viewed axially, winds in a clockwise and receding direction. Threads are always right-hand unless otherwise specified.

## The Helix Angle $\beta$

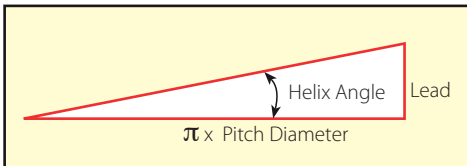

## Lead

The distance a threaded part moves axially, with respect to a fixed mating part, in one complete revolution. The lead is equal to the pitch multiplied by the number of thread starts.

# Machining a Multi-Start Thread

A thread in which the lead is an integral multiple, greater than one, of the pitch.  
 A multi-start thread permits a more rapid advance without a coarser (larger) thread form.

First Start Machined

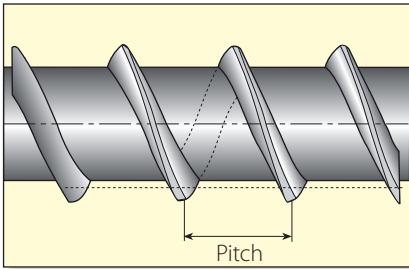

Second Start Machined

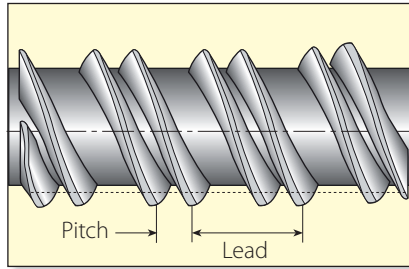

Third Start Machined  
(Final, 3 Starts Thread)

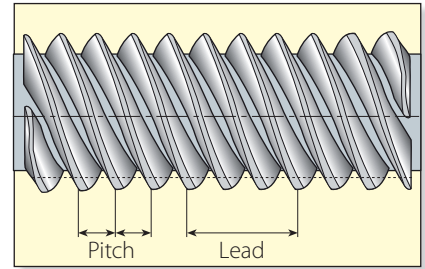

Lead = 3 x Pitch

## Insert Profile Styles

Partial Profile

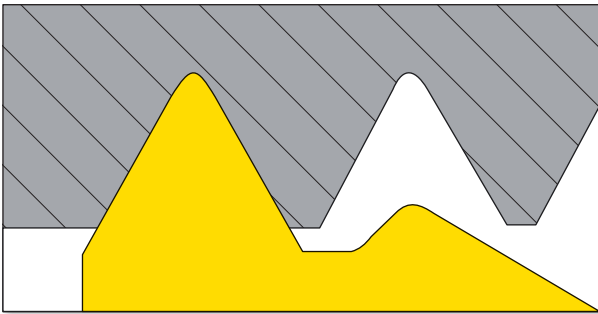

The V partial profile insert cuts without topping the outer diameter of the thread. The same insert can be used for a range of different thread pitches which have a common thread angle.

Full Profile

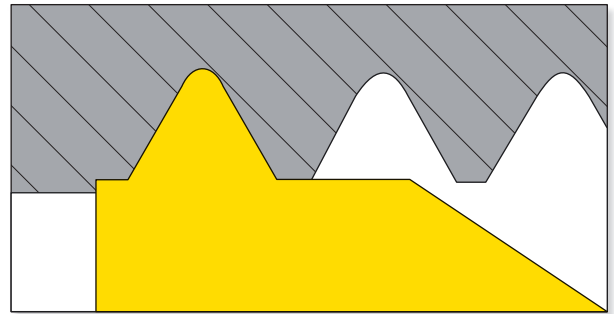

The full profile insert will form a complete thread profile including the crest. For every thread pitch and standard, a separate insert is required.

Full Profile for Fine Pitches

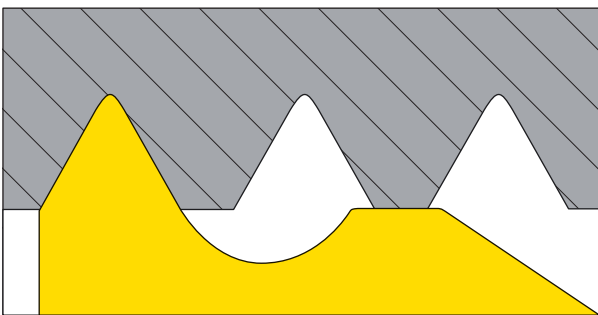

The full profile for Fine Pitches will form a complete thread.  
 The topping of the outer diameter is generated by the second tooth.

Semi Full

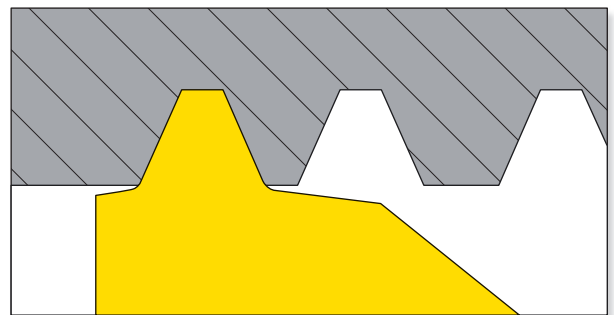

The Semi profile insert will form a complete thread including crest radius but without topping the outer diameter.  
 Mainly used for trapezoidal profiles.



# Thread Turning Methods

Thread	Inserts & Toolholder	Rotation	Feed Direction	Helix Method	Drawing No.
Right Hand External	EX RH	Counterclockwise	Towards chuck	Regular	1
	EX LH	Clockwise	From chuck	Reversed	2
Right Hand Internal	IN RH	Counterclockwise	Towards chuck	Regular	3
	IN LH	Clockwise	From chuck	Reversed	4
Left Hand External	EX LH	Clockwise	Towards chuck	Regular	5
	EX RH	Counterclockwise	From chuck	Reversed	6
Left Hand Internal	IN LH	Clockwise	Towards chuck	Regular	7
	IN RH	Counterclockwise	From chuck	Reversed	8

External RH Thread

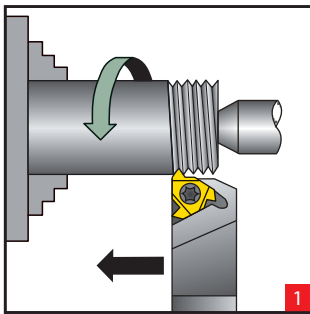

1

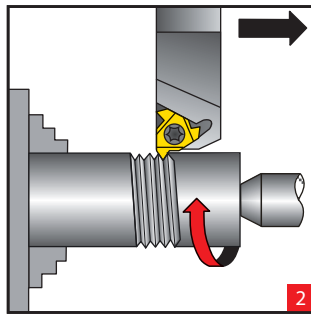

2

External LH Thread

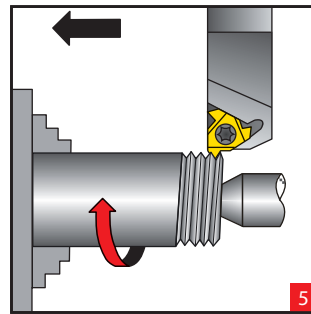

5

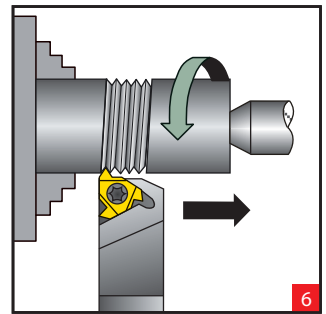

6

Internal RH Thread

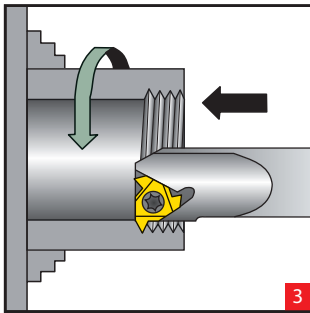

3

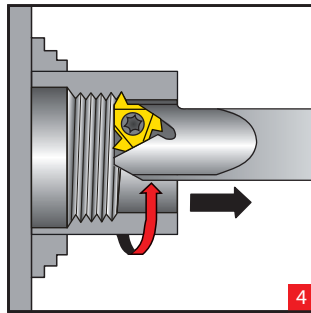

4

Internal LH Thread

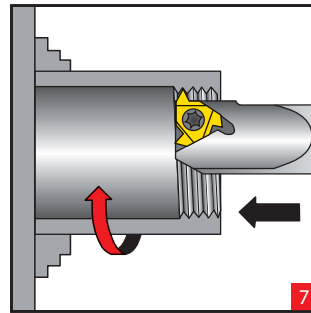

7

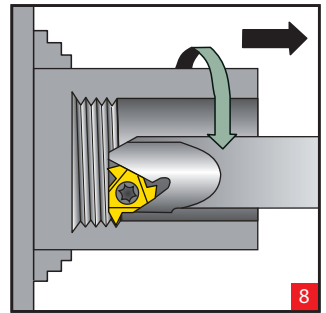

8

## Thread Infeed Methods

Radial Infeed

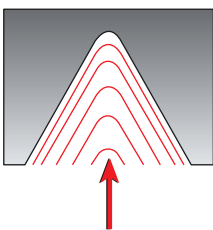

Radial infeed is the simplest and quickest method.

The feed is perpendicular to the turning axis, and both flanks of the insert perform the cutting operation.

Radial infeed is recommended in 3 cases:

- When the pitch is smaller than 16 tpi
- For material with short chips
- For work with hardened material

Flank Infeed (modified)

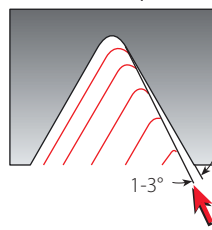

Flank infeed is recommended in the following cases:

- When the thread pitch is greater than 16 tpi, using the radial method, the effective cutting edge length is too large, resulting in chatter.
- For TRAPEZ and ACME. The radial method result in three cutting edges, making chip flow very difficult.

Alternate Flank Infeed

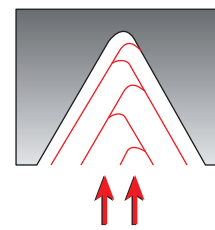

Use of the alternate flank method is recommended especially in large pitches and for materials with long chips.

This method divides the load equally on both flanks, resulting in equal wear along the cutting edges. Alternate flank infeed requires more complicated programming, and is not available on all lathes.

# Calculating the Helix Angle and Choosing The Right Anvil

## Flank Clearance Angle $\alpha$ (For External Inserts)

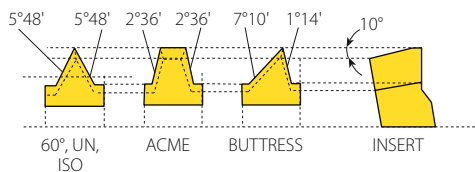

Vardex toolholders are designed to tilt the insert when seated in the toolholder (10° for external, 15° for internal tooling).

This results in the differing flank clearance angles, based on the geometry of the insert. To ensure that the side of the insert cutting edge will not rub on the workpiece, it is most important that the insert helix angle be correct - especially in profiles with small enclosed flank angles. This correction is provided by Vardex anvils.

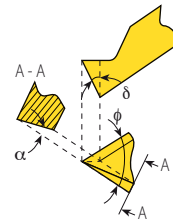

$$\alpha = \arctan(\tan \phi / 2 \times \tan \delta)$$

Where:  $\alpha$  - Flank clearance angle  
 $\delta$  - Tilt angle  
 $\phi$  - Enclosed flank angle

## Calculating the Helix Angle $\beta$

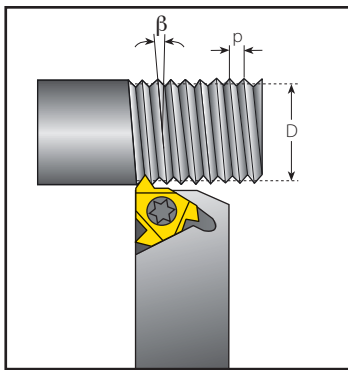

The helix angle is calculated by the following formula:

$$\beta = \arctan \frac{P \times N}{\pi \times D}$$

- $\beta$  - Helix angle [°]
- P - Pitch [inch]
- N - No. of starts
- D - Pitch diameter [inch]
- Lead = P x N

The helix angle can also be found from the diagram below.

## Helix Angle Diagram

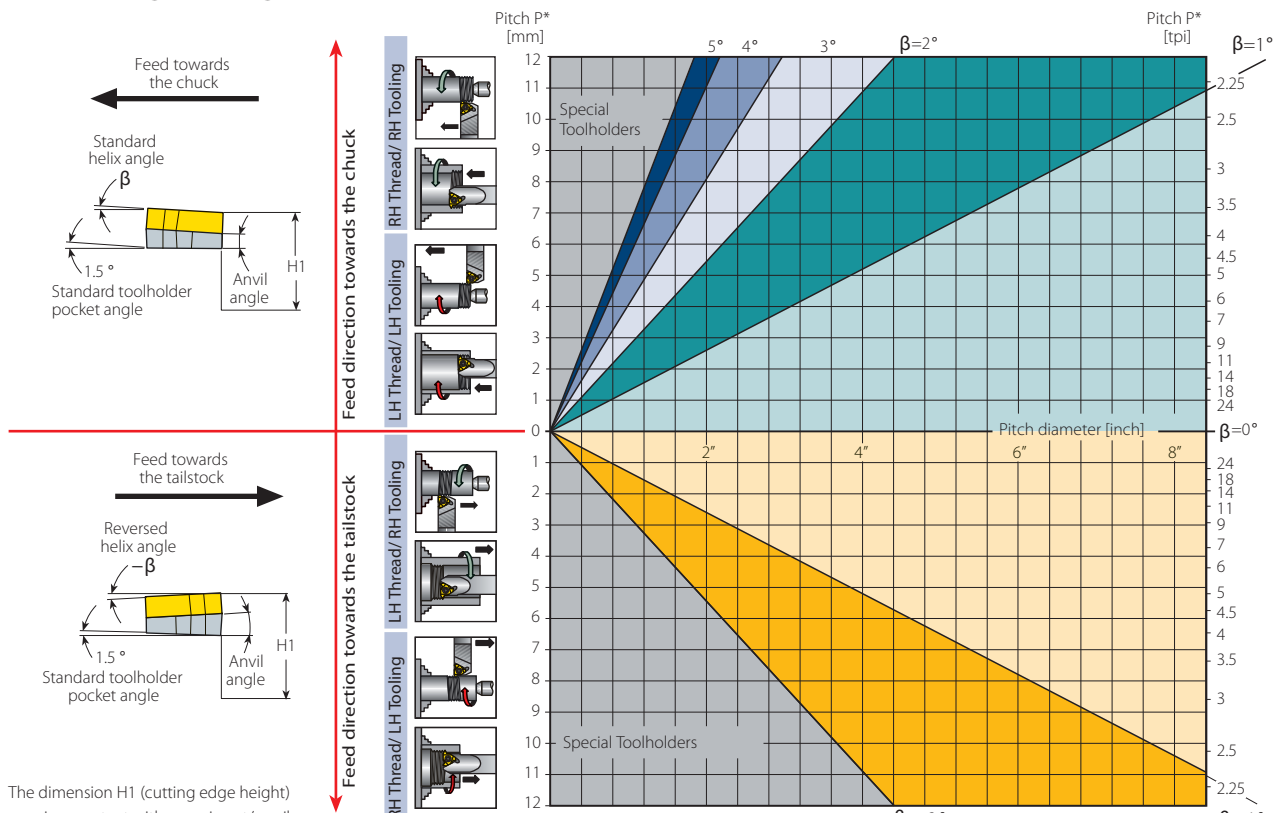

The dimension H1 (cutting edge height) remains constant with every insert/ anvil combination.

\*For Multi-start threads, use the lead value instead of the pitch

# Anvils

Resultant Helix Angle		4.5°	3.5°	2.5°	1.5°	0.5°	0°	-0.5°	-1.5°	
Insert Size		Holder			Ordering Code					
IC	L inch									
3/8"	0.63	ER / IL	YE3-3P	YE3-2P	YE3-1P	YE3	YE3-1N	YE3-1.5N	YE3-2N	YE3-3N
		EL / IR	YI3-3P	YI3-2P	YI3-1P	YI3	YI3-1N	YI3-1.5N	YI3-2N	YI3-3N
3/8" V6	0.63	ER	YE3-6C-3P	YE3-6C-2P	YE3-6C-1P	YE3-6C	YE3-6C-1N	YE3-6C-1.5N	YE3-6C-2N	YE3-6C-3N
		IR	YI3-6C-3P	YI3-6C-2P	YI3-6C-1P	YI3-6C	YI3-6C-1N	YI3-6C-1.5N	YI3-6C-2N	YI3-6C-3N
1/2"	0.87	ER / IL	YE4-3P	YE4-2P	YE4-1P	YE4	YE4-1N	YE4-1.5N	YE4-2N	YE4-3N
		EL / IR	YI4-3P	YI4-2P	YI4-1P	YI4	YI4-1N	YI4-1.5N	YI4-2N	YI4-3N
1/2"U	0.87	ER / IL	YE4U-3P	YE4U-2P	YE4U-1P	YE4U	YE4U-1N	YE4U-1.5N	YE4U-2N	YE4U-3N
		EL / IR	YI4U-3P	YI4U-2P	YI4U-1P	YI4U	YI4U-1N	YI4U-1.5N	YI4U-2N	YI4U-3N
5/8"	1.06	ER / IL	YE5-3P	YE5-2P	YE5-1P	YE5	YE5-1N	YE5-1.5N	YE5-2N	YE5-3N
		EL / IR	YI5-3P	YI5-2P	YI5-1P	YI5	YI5-1N	YI5-1.5N	YI5-2N	YI5-3N
5/8"U	1.06	ER / IL	YE5U-3P	YE5U-2P	YE5U-1P	YE5U	YE5U-1N	YE5U-1.5N	YE5U-2N	YE5U-3N
		EL / IR	YI5U-3P	YI5U-2P	YI5U-1P	YI5U	YI5U-1N	YI5U-1.5N	YI5U-2N	YI5U-3N
3/8"M	0.63	ER / IL			YE3M-1P	YE3M	YE3M-1N	YE3M-1.5N	YE3M-2N	
		EL / IR			YI3M-1P	YI3M	YI3M-1N	YI3M-1.5N		
1/2"M	0.87	ER / IL			YE4M-1P	YE4M	YE4M-1N	YE4M-1.5N	YE4M-2N	
		EL / IR			YI4M-1P	YI4M	YI4M-1N	YI4M-1.5N		
5/8"M	1.06	ER / IL				YE5M	YE5M-1N	YE5M-1.5N		
		EL / IR				YI5M	YI5M-1N	YI5M-1.5N		
1/2"Z	0.87	ER / IL			YE4Z-1P	YE4Z	YE4Z-1N			
		EL / IR			YI4Z-1P	YI4Z	YI4Z-1N			
5/8"Z	1.06	ER / IL				YE5Z				
		EL / IR				YI5Z				
1/2"T	0.87	ER / IL EL / IR					Y4T			

Thread Turning  
Technical Data

Standard Anvil		V6 Anvil		U Style Anvil		M Style Anvil		Z Style Anvil		T Style Anvil		
ER/IL	EL/IR	ER	IR	ER/IL	EL/IR	ER/IL	EL/IR	ER/IL	EL/IR	ER/IL	EL/IR	
V6 is indicated on the backside												Same anvil turned over

## Anvil Kits

Anvil Size		Ordering Code	Included Anvils:
IC	L inch		
3/8"	0.63	ABY3	YE3-2P, 1P, 1N, 2N, 3N
			YI3-2P, 1P, 1N, 2N, 3N
3/8" V6	0.63	ABY3-6C	YE3-6C-2P, 1P, 1N, 2N, 3N
			YI3-6C-2P, 1P, 1N, 2N, 3N
1/2"	0.87	ABY4	YE4-2P, 1P, 1N, 2N, 3N
			YI4-2P, 1P, 1N, 2N, 3N
1/2"U	0.87	ABY4U	YE4U-2P, 1P, 1N, 2N, 3N
			YI4U-2P, 1P, 1N, 2N, 3N
5/8"	1.06	ABYE5	YE5-2P, 1P, 1N, 2N, 3N
		ABYI5	YI5-2P, 1P, 1N, 2N, 3N
5/8"U	1.06	ABYE5U	YE5U-2P, 1P, 1N, 2N, 3N
		ABYI5U	YI5U-2P, 1P, 1N, 2N, 3N

To ensure that you always have on hand an assortment of anvils for any job, we recommend that anvil kits be readily available.

**Important!**

**Use a V6 anvil when using a V6 insert.**









For External RH  
use YE3-6C anvil.







For Internal RH  
use YI3-6C anvil.

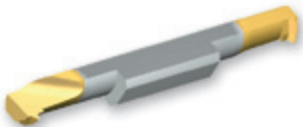

# Grades and Their Applications

General Use		
VKX	VTX	VCB
 <p>Superior general purpose grade, excellent in steels and stainless steels, recommended for rigid cutting conditions, ground or sintered chipbreaker styles. TiN coated.</p>	 <p>General purpose grade with tough submicron substrate. Provides good fracture toughness in non-rigid cutting conditions. TiAlN coated.</p>	 <p>Vardex sintered chipbreaker with ground profile for machining materials with long chips. TiAlN coated.</p>
Stainless Steel	Non Ferrous, High Temperature Alloys and Titanium	
VM7	VK2	VK2P
 <p>Specialty grade for threading stainless steel. Multi-layer PVD coated.</p>	 <p>Uncoated grade for non-ferrous, aluminium, high temperature and titanium alloys.</p>	 <p>Highly-polished version of the VK2 uncoated grade for high quality surface finish in aluminium.</p>

## **MINIPRO**

Micro	Mini "5L" & Mini IC 6.0	Mini IC 4.0
VMX	VHX	VTX
 <p>General purpose carbide grade for Micro double-ended inserts. TiN coated.</p>	 <p>HSS grade for Mini "L" and Mini 6.0 inserts; for low cutting speeds, TiN coated.</p>	 <p>Carbide grade for Mini 4.0. For machining stainless steel and general use. TiAlN coated.</p>
	VKP	VBX
	 <p>General purpose carbide grade for Mini "L" and Mini 6.0 inserts, TiN coated.</p>	 <p>Carbide grade for Mini 4.0. For machining steel and general use. TiCN coated.</p>

# Recommended Grades and Cutting Speeds Vc [ft/min] not Including MiniPro Line

Material Group	Vardex No.	Material		Hardness Brinell HB	Vc [ft/min]				
					Coated				Uncoated
					VKX	VCB	VM7	VTX	
<b>P</b> Steel	1	Unalloyed steel	Low carbon (C=0.1-0.25%)	125	377-623	377-623		377-623	
	2		Medium carbon (C=0.25-0.55%)	150	328-574	328-541		328-574	
	3		High carbon (C=0.55-0.85%)	170	295-541	295-508		295-541	
	4	Low alloy steel (alloying elements ≤5%)	Non hardened	180	328-590	328-590		328-590	
	5		Hardened	275	246-459	246-459		246-459	
	6		Hardened	350	229-443	229-443		229-443	
	7	High alloy steel (alloying elements >5%)	Annealed	200	262-393	262-393		262-393	
	8		Hardened	325	164-328	164-328		164-328	
	9	Cast steel	Low alloy (alloying elements <5%)	200	229-426	229-426		229-426	
	10		High alloy (alloying elements >5%)	225	197-393	197-393		197-393	
<b>M</b> Stainless Steel	11	Stainless steel Ferritic	Non hardened	200	229-426	229-426	229-492	229-426	
	12		Hardened	330	197-377	164-311	197-410	197-377	
	13	Stainless steel Austenitic	Austenitic	180	295-459	262-393	295-524	295-459	
	14		Super Austenitic	200	131-361	98-328	131-393	131-361	
	15	Stainless steel Cast ferritic	Non hardened	200	295-393	295-393	295-492	295-393	
	16		Hardened	330	213-361	213-361	213-393	213-361	
	17	Stainless steel Cast austenitic	Austenitic	200	279-361	279-361	279-393	279-361	
	18		Hardened	330	197-328	197-328	197-361	197-328	
<b>K</b> Cast Iron	28	Malleable Cast iron	Ferritic (short chips)	130	197-229	229-393		197-229	
	29		Pearlitic (long chips)	230	197-475	229-393		197-475	
	30	Grey Cast iron	Low tensile strength	180	229-426	229-426		229-426	
	31		High tensile strength	260	197-377	197-328		197-377	
	32	Nodular SG iron	Ferritic	160	410-524	410-524		410-524	
	33		Pearlitic	260	295-393	295-393		295-393	
<b>N(K)</b> Non-Ferrous Metals	34	Aluminium alloys Wrought	Non aging	60	328-1196	328-819		328-1196	328-819
	35		Aged	100	262-721	262-590		262-721	262-524
	36	Aluminium alloys Cast	Cast	75	656-1312	656-1312		656-1312	262-393
	37		Cast & aged	90	656-918	656-918		656-918	229-328
	38	Aluminium alloys Cast Si 13-22%		130	197-590	197-492		197-590	164-393
	39	Copper and copper alloys	Brass	90	262-738	262-688		262-738	229-557
	40		Bronze and non leaded copper	100	262-836	262-688		262-836	229-557
<b>S(M)</b> Heat Resistant Material	19	High temperature alloys	Annealed (Iron based)	200	148-197	148-197		148-197	98-164
	20		Aged (Iron based)	280	98-164	98-164		98-164	82-131
	21		Annealed (Nickel or Cobalt based)	250	66-98	66-98		66-98	66-98
	22		Aged (Nickel or Cobalt based)	350	49-82	49-82		49-82	49-82
	23	Titanium alloys	Pure 99.5 Ti	400Rm	459-557	459-557		459-557	197-328
	24		α+β alloys	1050Rm	164-229	164-229		164-229	131-197
<b>H(K)</b> Hardened Material	25	Extra hard steel	Hardened & tempered	45-50HRC	148-197	148-197		148-197	
	26			51-55HRC	131-164	131-164		131-164	

Thread Turning Technical Data

## Calculation of N [RPM]

$$N = \frac{12 \times V_c}{\pi \times D}$$

$$V_c = \frac{N \times \pi \times D}{12}$$

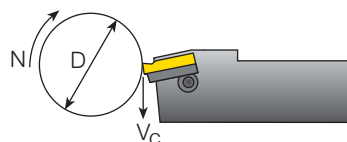

- N - Revolution Per Minute [RPM]
- V<sub>c</sub> - Cutting Speed [ft/min]
- D - Workpiece Diameter [inch]

# Recommended Grades and Cutting Speeds

## Vc [ft/min] Mini, Micro











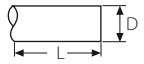

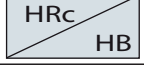



Material Group	Vardex No.	Material	Hardness Brinell HB	Vc [ft/min]				
				Coated				
				VMX (Micro)	VKP (Mini)	VTX (Mini)	VHX (Mini)	
<b>P</b> Steel	1	Unalloyed steel	Low carbon (C=0.1-0.25%)	125	164-393	459-656	492-656	66-164
	2		Medium carbon (C=0.25-0.55%)	150	131-328	393-590	426-590	49-131
	3		High Carbon (C=0.55-0.85%)	170	98-262	361-590	393-590	49-98
	4	Low alloy steel (alloying elements ≤5%)	Non hardened	180	164-229	328-508	361-508	66-148
	5		Hardened	275	131-197	295-475	328-475	33-82
	6		Hardened	350	98-164	262-443	295-443	33-82
	7	High alloy steel (alloying elements >5%)	Annealed	200	98-164	213-377	229-377	
	8		Hardened	325	82-131	164-328	197-328	
	9	Cast steel	Low alloy (alloying elements <5%)	200	98-164	98-164	98-164	82-131
	10		High alloy (alloying elements >5%)	225	82-131	82-131	98-131	82-131
<b>M</b> Stainless Steel	11	Stainless steel Ferritic	Non hardened	200	197-328	262-393	295-393	
	12		Hardened	330	131-197	180-311	197-311	
	13	Stainless steel Austenitic	Austenitic	180	164-295	197-328	229-328	
	14		Super Austenitic	200	131-197	164-295	197-295	
	15	Stainless steel Cast Ferritic	Non hardened	200	131-197	197-262	229-262	
	16		Hardened	330	98-164	148-213	164-213	
	17	Stainless steel Cast austenitic	Austenitic	200	131-197	164-229	197-229	
	18		Hardened	330	98-164	131-197	131-197	
<b>K</b> Cast Iron	28	Malleable Cast iron	Ferritic (short chips)	130	164-229	197-262	229-262	
	29		Pearlitic (long chips)	230	164-229	197-262	229-262	
	30	Grey cast iron	Low tensile strength	180	164-229	197-262	229-262	
	31		High tensile strength	260	131-197	131-229	131-229	
	32	Nodular SG iron	Ferritic	160	164-229	197-262	229-262	
33	Pearlitic		260	197-262	229-295	262-295		
<b>N(K)</b> Non-Ferrous Metals	34	Aluminium alloys Wrought	Non aging	60	328-983	262-787	295-787	98-197
	35		Aged	100	328-492	328-557	361-557	82-164
	36	Aluminium alloys	Cast	75	328-492	328-492	361-492	82-164
	37		Cast & aged	90	197-328	197-328	229-328	66-131
	38		Aluminium alloys Cast Si 13-22%	130	328-492	328-492	361-492	49-98
	39	Copper and copper alloys	Brass	90	197-328	262-656	295-656	49-115
	40		Bronze and non leaded copper	100	197-328	262-656	295-656	49-115
<b>S(M)</b> Heat Resistant Material	19	High temperature alloys	Annealed (Iron based )	200	82-148	82-148	98-148	
	20		Aged (Iron based)	280	66-98	66-98	66-98	
	21		Annealed (Nickel or Cobalt based)	250	49-66	49-66	49-66	
	22		Aged (Nickel or Cobalt based)	350	33-49	33-49	49-66	
	23	Titanium alloys	Pure 99.5 Ti	400Rm	197-328	197-328	229-328	
	24		α+β alloys	1050Rm	131-164	131-164	131-164	
<b>H(K)</b> Hardened Material	25	Extra hard steel	Hardened & tempered	45-50HRc	66-131	66-131	66-131	
	26			51-55HRc	66-131	66-131	66-131	

## Number of Passes

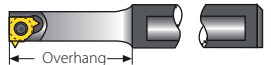
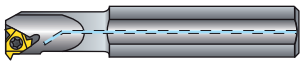
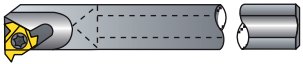
Pitch	mm	0.50	0.75	1.00	1.25	1.50	1.75	2.00	2.50	3.00	3.50	4.00	4.50	5.00	5.50	6.00	8.00
	tpi	48	32	24	20	16	14	12	10	8	7	6	5.5	5	4.5	4	3
No. of passes		4-6	4-7	4-8	5-9	6-10	7-12	7-12	8-14	9-16	10-18	11-18	11-19	12-20	12-20	12-20	15-24
No. of passes (SCB)		3-4	3-4	3-5	4-6	5-6	6-8	6-8	8-10	9-12	10-14						
No. of passes (Micro & Mini)		6-9	6-11	6-12	8-14	9-15	11-18	11-18									

## Cutting Conditions Depends On:

<b>Workpiece</b>	Material Type	
	Material Dimension: Diameter and Length	
	Chipflow Character	
	Material Hardness	
<b>Thread Application</b>	External or Internal	
	Profile Shape	
	Surface Finish	
<b>Machine</b>	Machine Stability	
	Max. RPM	
	Clamping System Stability	
<b>Coolant</b>	Coolant Type	
<b>Holder</b>	Holder Cross Section Area	
	Holder Overhang	
	Through Coolant Option	
	Shank Type: Carbide, Alloy, Carbide Implant	
<b>Insert</b>	Grade	<b>P M K N S H</b>
	Profile Shape: Pitch and Depth	
	Nose Radius	
	Chipbreaker Style	

# Radial infeed per pass

## UN External

Number of passes	Pitch/tpi	Cutting Speed																	
		32	28	24	20	18	16	14	13	12	11	10	9	8	7	6	5	4.5	4
1		0.007	0.007	0.007	0.008	0.009	0.009	0.009	0.009	0.010	0.011	0.011	0.011	0.012	0.014	0.014	0.017	0.017	0.018
2		0.006	0.006	0.006	0.007	0.008	0.008	0.008	0.009	0.010	0.009	0.010	0.010	0.011	0.013	0.013	0.015	0.016	0.017
3		0.004	0.004	0.006	0.005	0.006	0.006	0.006	0.007	0.007	0.007	0.007	0.008	0.008	0.010	0.010	0.012	0.014	0.014
4		0.002	0.004	0.004	0.004	0.005	0.005	0.005	0.006	0.006	0.006	0.006	0.007	0.007	0.008	0.009	0.011	0.011	0.013
5			0.002	0.002	0.004	0.004	0.004	0.004	0.005	0.006	0.006	0.006	0.006	0.006	0.007	0.008	0.009	0.009	0.012
6					0.002	0.002	0.004	0.004	0.005	0.005	0.005	0.005	0.006	0.006	0.007	0.007	0.009	0.009	0.010
7							0.002	0.004	0.004	0.005	0.005	0.005	0.005	0.006	0.006	0.007	0.008	0.008	0.009
8								0.002	0.002	0.002	0.004	0.005	0.005	0.005	0.006	0.006	0.007	0.008	0.009
9											0.002	0.004	0.005	0.005	0.006	0.006	0.007	0.007	0.009
10												0.002	0.004	0.005	0.005	0.005	0.007	0.007	0.008
11															0.005	0.007	0.006	0.007	
12															0.004	0.006	0.006	0.007	
13															0.002	0.005	0.006	0.006	
14																0.002	0.006	0.006	
15																	0.005	0.005	
16																	0.002	0.002	

## UN Internal

Number of passes	Pitch/tpi	Cutting Speed																	
		32	28	24	20	18	16	14	13	12	11	10	9	8	7	6	5	4.5	4
1		0.007	0.006	0.007	0.007	0.009	0.009	0.009	0.009	0.010	0.010	0.011	0.011	0.012	0.013	0.014	0.017	0.017	0.018
2		0.005	0.005	0.006	0.006	0.007	0.007	0.008	0.008	0.009	0.009	0.010	0.010	0.011	0.013	0.013	0.015	0.015	0.017
3		0.004	0.004	0.005	0.005	0.005	0.006	0.006	0.006	0.007	0.007	0.007	0.007	0.008	0.009	0.010	0.012	0.013	0.015
4		0.002	0.003	0.004	0.004	0.005	0.005	0.005	0.005	0.006	0.006	0.006	0.006	0.007	0.008	0.008	0.010	0.010	0.012
5			0.002	0.002	0.004	0.004	0.004	0.004	0.005	0.005	0.006	0.005	0.006	0.006	0.007	0.007	0.009	0.009	0.011
6					0.002	0.002	0.004	0.004	0.004	0.004	0.005	0.005	0.005	0.005	0.006	0.006	0.008	0.008	0.009
7							0.002	0.004	0.004	0.004	0.005	0.004	0.005	0.005	0.006	0.006	0.007	0.007	0.009
8								0.002	0.002	0.002	0.004	0.004	0.004	0.004	0.005	0.006	0.007	0.007	0.008
9											0.004	0.004	0.004	0.004	0.005	0.005	0.006	0.007	0.008
10											0.002	0.002	0.004	0.004	0.005	0.005	0.006	0.006	0.007
11													0.002	0.004	0.004	0.005	0.006	0.006	0.007
12														0.002	0.002	0.004	0.006	0.006	0.006
13															0.004	0.005	0.006	0.006	
14															0.002	0.002	0.005	0.006	
15																	0.005	0.005	
16																	0.002	0.002	

Thread Turning  
Technical Data



## Radial infeed per pass

### ISO External

Number of passes	Pitch/mm	Cutting Speed															
		Lower	0.5	0.75	1	1.25	1.5	1.75	2	2.5	3	3.5	4	4.5	5	5.5	6
1		0.004	0.006	0.007	0.007	0.009	0.009	0.009	0.010	0.011	0.013	0.013	0.015	0.016	0.017	0.018	
2		0.003	0.006	0.006	0.007	0.008	0.008	0.009	0.009	0.010	0.012	0.012	0.013	0.015	0.016	0.017	
3		0.003	0.004	0.005	0.006	0.007	0.006	0.007	0.007	0.008	0.009	0.009	0.011	0.013	0.013	0.014	
4		0.002	0.002	0.004	0.004	0.006	0.005	0.006	0.007	0.007	0.008	0.009	0.009	0.011	0.011	0.012	
5				0.002	0.004	0.005	0.004	0.006	0.006	0.006	0.007	0.007	0.009	0.009	0.009	0.011	
6					0.002	0.002	0.004	0.005	0.005	0.006	0.007	0.007	0.008	0.009	0.009	0.009	
7							0.004	0.004	0.005	0.005	0.006	0.006	0.007	0.008	0.008	0.008	
8							0.002	0.002	0.004	0.005	0.006	0.006	0.007	0.007	0.007	0.007	
9									0.004	0.005	0.006	0.006	0.006	0.007	0.007	0.008	
10									0.002	0.004	0.005	0.005	0.006	0.007	0.007	0.007	
11										0.004	0.004	0.005	0.006	0.006	0.006	0.006	
12										0.002	0.002	0.005	0.005	0.006	0.006	0.006	
13												0.004	0.005	0.005	0.005	0.006	
14												0.002	0.002	0.002	0.005	0.006	
15															0.005	0.005	
16															0.002	0.002	

### ISO Internal

Number of passes	Pitch/mm	Cutting Speed															
		Lower	0.5	0.75	1	1.25	1.5	1.75	2	2.5	3	3.5	4	4.5	5	5.5	6
1		0.004	0.006	0.007	0.007	0.009	0.009	0.010	0.011	0.011	0.013	0.013	0.014	0.017	0.017	0.018	
2		0.003	0.005	0.006	0.006	0.008	0.008	0.009	0.010	0.010	0.012	0.012	0.013	0.015	0.015	0.017	
3		0.003	0.004	0.004	0.005	0.006	0.006	0.007	0.007	0.008	0.009	0.009	0.011	0.012	0.013	0.014	
4		0.002	0.002	0.004	0.004	0.005	0.005	0.006	0.006	0.006	0.007	0.008	0.009	0.010	0.010	0.011	
5				0.002	0.004	0.004	0.004	0.004	0.005	0.006	0.007	0.007	0.008	0.009	0.009	0.010	
6					0.002	0.002	0.003	0.004	0.005	0.005	0.006	0.006	0.007	0.008	0.008	0.009	
7							0.003	0.004	0.004	0.005	0.006	0.006	0.006	0.007	0.007	0.008	
8							0.002	0.002	0.004	0.004	0.005	0.005	0.006	0.006	0.007	0.007	
9									0.004	0.004	0.005	0.005	0.006	0.006	0.006	0.007	
10									0.002	0.004	0.004	0.005	0.005	0.006	0.006	0.006	
11										0.003	0.004	0.004	0.005	0.006	0.006	0.006	
12										0.002	0.002	0.004	0.005	0.006	0.006	0.006	
13												0.004	0.004	0.005	0.005	0.006	
14												0.002	0.002	0.002	0.005	0.006	
15															0.005	0.005	

# Radial infeed per pass

## UNJ External & Internal

Number of passes	Lower					Cutting Speed					Higher
	Pitch/tpi	32	28	24	20	18	16	14	12	10	8
1	0.006	0.006	0.007	0.007	0.008	0.009	0.009	0.010	0.010	0.011	
2	0.006	0.005	0.006	0.006	0.007	0.007	0.008	0.009	0.009	0.011	
3	0.004	0.004	0.006	0.005	0.006	0.006	0.006	0.007	0.007	0.008	
4	0.002	0.004	0.004	0.004	0.005	0.005	0.005	0.006	0.006	0.006	
5		0.002	0.002	0.004	0.004	0.004	0.004	0.004	0.005	0.005	0.006
6				0.002	0.002	0.004	0.004	0.004	0.004	0.005	0.005
7						0.002	0.004	0.004	0.004	0.005	0.005
8							0.002	0.002	0.004	0.004	0.005
9										0.004	0.005
10										0.002	0.004
11											0.004
12											0.002

## NPT External & Internal

Number of passes	Lower		Cutting Speed			Higher
	Pitch/tpi	27	18	14	11.5	8
1	0.008		0.008	0.009	0.009	0.010
2	0.006		0.006	0.007	0.007	0.009
3	0.006		0.006	0.006	0.007	0.008
4	0.005		0.005	0.006	0.006	0.007
5	0.005		0.005	0.005	0.006	0.007
6	0.004		0.004	0.005	0.005	0.007
7	0.004		0.004	0.004	0.005	0.007
8	0.002		0.002	0.004	0.005	0.007
9				0.004	0.004	0.006
10				0.002	0.004	0.006
11					0.004	0.006
12					0.002	0.005
13						0.005
14						0.004
15						0.002

Thread Turning  
Technical Data

## Radial infeed per pass

### NPTF External & Internal

Number of passes	Pitch/tpi	Cutting Speed				
		Lower				Higher
		27	18	14	11.5	8
1		0.006	0.008	0.009	0.009	0.009
2		0.006	0.007	0.009	0.009	0.009
3		0.004	0.006	0.006	0.007	0.009
4		0.004	0.005	0.006	0.006	0.007
5		0.003	0.004	0.005	0.005	0.007
6		0.002	0.004	0.004	0.004	0.006
7			0.004	0.004	0.004	0.006
8			0.002	0.004	0.004	0.006
9				0.004	0.004	0.005
10				0.002	0.004	0.005
11					0.004	0.005
12						0.005
13						0.004
14						0.004
15						0.004

### ACME External & Internal

Number of passes	Pitch/tpi	Cutting Speed							
		Lower							Higher
		16	14	12	10	8	6	5	4
1		0.009	0.009	0.010	0.010	0.011	0.013	0.014	0.015
2		0.008	0.007	0.009	0.009	0.010	0.011	0.013	0.014
3		0.007	0.007	0.007	0.008	0.008	0.009	0.010	0.012
4		0.006	0.006	0.006	0.007	0.007	0.008	0.009	0.011
5		0.005	0.005	0.005	0.006	0.006	0.007	0.009	0.010
6		0.002	0.004	0.005	0.005	0.005	0.007	0.008	0.009
7			0.002	0.004	0.004	0.005	0.006	0.007	0.008
8				0.002	0.004	0.005	0.006	0.007	0.008
9					0.002	0.005	0.008	0.007	0.008
10						0.004	0.006	0.006	0.007
11						0.004	0.006	0.006	0.007
12						0.002	0.005	0.006	0.006
13							0.002	0.005	0.006
14								0.002	0.006
15									0.006

# Radial infeed per pass

## STUB ACME External & Internal

Number of passes	Cutting Speed								
	Pitch/tpi	16	14	12	10	8	6	5	4
1	0.007	0.009	0.009	0.009	0.010	0.012	0.013	0.014	
2	0.005	0.006	0.006	0.007	0.007	0.009	0.010	0.011	
3	0.004	0.005	0.005	0.006	0.007	0.007	0.008	0.009	
4	0.002	0.004	0.004	0.006	0.006	0.007	0.007	0.008	
5		0.002	0.004	0.005	0.006	0.006	0.007	0.008	
6			0.002	0.004	0.005	0.006	0.006	0.007	
7				0.002	0.004	0.006	0.006	0.006	
8					0.002	0.005	0.006	0.006	
9						0.002	0.005	0.005	
10							0.002	0.005	
11								0.004	
12									0.002

## W External & Internal

Number of passes	Cutting Speed																	
	Pitch/tpi	28	26	20	19	18	16	14	12	11	10	9	8	7	6	5	4.5	4
1	0.007	0.007	0.008	0.008	0.008	0.008	0.008	0.009	0.010	0.010	0.011	0.011	0.012	0.013	0.014	0.017	0.017	0.018
2	0.006	0.006	0.007	0.007	0.007	0.007	0.007	0.008	0.010	0.009	0.010	0.010	0.011	0.013	0.013	0.016	0.016	0.017
3	0.004	0.005	0.006	0.006	0.006	0.006	0.006	0.007	0.008	0.008	0.008	0.008	0.009	0.010	0.011	0.014	0.014	0.014
4	0.004	0.004	0.005	0.005	0.005	0.005	0.005	0.006	0.006	0.007	0.007	0.007	0.007	0.009	0.009	0.011	0.012	0.013
5	0.002	0.002	0.004	0.005	0.005	0.004	0.005	0.006	0.006	0.006	0.006	0.006	0.007	0.008	0.008	0.010	0.010	0.012
6			0.002	0.002	0.002	0.004	0.005	0.006	0.006	0.006	0.006	0.006	0.006	0.007	0.008	0.009	0.009	0.011
7						0.004	0.043	0.005	0.005	0.005	0.006	0.006	0.007	0.007	0.009	0.009	0.009	0.011
8						0.002	0.002	0.002	0.005	0.005	0.005	0.006	0.006	0.007	0.007	0.008	0.009	0.010
9									0.002	0.005	0.005	0.005	0.006	0.006	0.007	0.008	0.008	0.009
10										0.002	0.005	0.005	0.006	0.006	0.007	0.007	0.007	0.009
11											0.002	0.005	0.005	0.006	0.007	0.007	0.007	0.008
12												0.002	0.002	0.005	0.006	0.006	0.006	0.007
13														0.005	0.005	0.006	0.007	
14															0.002	0.002	0.006	0.006
15																	0.005	0.005

Thread Turning  
Technical Data

## Radial infeed per pass

### BSPT External & Internal

Number of passes	Pitch/tpi	Cutting Speed			
		Lower			Higher
		<b>28</b>	<b>19</b>	<b>14</b>	<b>11</b>
1		0.007	0.009	0.009	0.010
2		0.006	0.007	0.008	0.009
3		0.004	0.006	0.007	0.008
4		0.004	0.005	0.006	0.007
5		0.002	0.005	0.005	0.006
6			0.002	0.005	0.006
7				0.004	0.005
8				0.002	0.005
9					0.002

### TRAPEZ External & Internal

Number of passes	Pitch/tpi	Cutting Speed							
		Lower						Higher	
		<b>16</b>	<b>1.5</b>	<b>2</b>	<b>3</b>	<b>4</b>	<b>5</b>	<b>6</b>	<b>7</b>
1		0.009	0.009	0.009	0.010	0.014	0.014	0.015	0.016
2		0.008	0.007	0.008	0.009	0.013	0.013	0.014	0.014
3		0.007	0.007	0.006	0.007	0.010	0.010	0.012	0.013
4		0.006	0.006	0.005	0.006	0.009	0.009	0.011	0.012
5		0.005	0.005	0.004	0.005	0.009	0.009	0.010	0.011
6		0.002	0.004	0.002	0.005	0.008	0.008	0.010	0.011
7			0.002		0.004	0.007	0.007	0.009	0.011
8					0.002	0.007	0.007	0.008	0.010
9						0.007	0.007	0.008	0.009
10						0.006	0.006	0.007	0.009
11						0.005	0.006	0.007	0.009
12						0.005	0.005	0.006	0.008
13						0.002	0.005	0.006	0.008
14							0.002	0.006	0.007
15								0.006	0.007
16								0.002	0.002

# Number of Passes and Depth of Cut per Pass for Multi+ Inserts



Standard	Insert Type	Insert Size		Pitch	Teeth	Ordering Code	Passes	Depth of cut per pass			
		IC	L inch					RH			
							1	2	3	4	
ISO External	M+	3/8"	0.63	1.0 mm	3	3ER1.0ISO3M+...	2	0.013	0.012		
				1.5 mm	2	3ER1.5ISO2M+...	3	0.013	0.012	0.011	
				2.0 mm	2	3ER2.0ISO2M+...	3	0.018	0.016	0.015	
		1/2"	0.87	1.5 mm	3	4ER1.5ISO3M+...	2	0.019	0.018		
				2.0 mm	2	4ER2.0ISO2M+...	3	0.018	0.016	0.015	
				2.0 mm	3	4ER2.0ISO3M+...	2	0.025	0.023		
	2.5 mm	2	4ER2.5ISO2M+...	4	0.018	0.017	0.015	0.014			
	5/8"	1.06	3.0 mm	2	5ER3.0ISO2M+...	4	0.021	0.019	0.018	0.015	
	T+	1/2"T	0.87	1.5 mm	8	4ER1.5ISO8T+...	1	0.037			
	2.0 mm	8	4ER2.0ISO8T+...	1	0.048						
ISO Internal	M+	3/8"	0.63	1.0 mm	3	3IR1.0ISO3M+...	2	0.012	0.011		
				1.5 mm	2	3IR1.5ISO2M+...	3	0.012	0.011	0.011	
				2.0 mm	2	3IR2.0ISO2M+...	3	0.017	0.015	0.014	
		1/2"	0.87	1.5 mm	3	4IR1.5ISO3M+...	2	0.018	0.016		
				2.0 mm	2	4IR2.0ISO2M+...	3	0.017	0.015	0.014	
				2.0 mm	3	4IR2.0ISO3M+...	2	0.023	0.022		
	5/8"	1.06	3.0 mm	2	5IR3.0ISO2M+...	4	0.019	0.018	0.017	0.015	
	T+	1/2"	0.87	1.5 mm	8	4IR1.5ISO8T+...	1	0.034			
	2.0 mm	8	4IR2.0ISO8T+...	1	0.045						
	UN External	M+	3/8"	0.63	20 tpi	3	3ER20UN3M+...	2	0.016	0.015	
18 tpi					2	3ER18UN2M+...	3	0.013	0.011	0.011	
18 tpi					3	3ER18UN3M+...	2	0.018	0.017		
16 tpi					2	3ER16UN2M+...	3	0.014	0.013	0.012	
14 tpi					2	3ER14UN2M+...	3	0.017	0.015	0.015	
12 tpi					2	3ER12UN2M+...	3	0.019	0.017	0.016	
1/2"		0.87	16 tpi	3	4ER16UN3M+...	2	0.020	0.019			
			14 tpi	2	4ER14UN2M+...	3	0.017	0.015	0.015		
			12 tpi	2	4ER12UN2M+...	3	0.019	0.017	0.016		
			12 tpi	3	4ER12UN3M+...	2	0.026	0.025			
			11 tpi	2	4ER11UN2M+...	4	0.017	0.015	0.014	0.013	
			10 tpi	2	4ER10UN2M+...	4	0.018	0.017	0.016	0.014	
5/8"		1.06	8 tpi	2	5ER8UN2M+...	4	0.022	0.02	0.019	0.016	
UN Internal	M+	3/8"	0.63	12 tpi	2	3IR12UN2M+...	3	0.018	0.015	0.015	
				14 tpi	2	3IR14UN2M+...	3	0.016	0.014	0.013	
				16 tpi	2	3IR16UN2M+...	3	0.013	0.012	0.011	
	1/2"	0.87	16 tpi	3	4IR16UN3M+...	2	0.019	0.017			
			14 tpi	2	4IR14UN2M+...	3	0.016	0.014	0.013		
			12 tpi	2	4IR12UN2M+...	3	0.018	0.015	0.015		
			12 tpi	3	4IR12UN3M+...	2	0.025	0.023			
5/8"	1.06	8 tpi	2	5IR8UN2M+...	4	0.020	0.019	0.017	0.015		
BSW External	M+	3/8"	0.63	28 tpi	2	3ER28W2M+...	3	0.009	0.008	0.008	
				19 tpi	2	3ER19W2M+...	3	0.013	0.011	0.011	
				19 tpi	3	3ER19W3M+...	2	0.018	0.016		
				14 tpi	2	3ER14W2M+...	3	0.017	0.015	0.014	
		1/2"	0.87	14 tpi	3	4ER14W3M+...	2	0.024	0.022		
				11 tpi	2	4ER11W2M+...	4	0.017	0.015	0.014	0.012

Thread Turning  
Technical Data

# Number of Passes and Depth of Cut per Pass for Multi+ Inserts



Standard	Insert Type	Insert Size		Pitch	Teeth	Ordering Code	Passes	Depth of cut per pass				
		IC	L inch					RH				
							1	2	3	4		
BSW Internal	M+	3/8"	0.63	14	tpi	2	3R14W2M+...	3	0.017	0.015	0.014	
		1/2"	0.87	11	tpi	2	4R11W2M+...	4	0.017	0.015	0.014	0.012
NPT External	M+	3/8"	0.63	14	tpi	2	3ER14NPT2M+...	3	0.020	0.018	0.017	
		1/2"	0.87	11.5	tpi	2	4ER11.5NPT2M+...	4	0.018	0.017	0.017	0.016
		5/8"	1.06	11.5	tpi	3	5ER11.5NPT3M+...	4	0.019	0.017	0.017	0.015
	Z+	1/2"	0.87	11.5	tpi	2	4ER11.5NPT2Z+...	4	0.018	0.017	0.017	0.016
				8	tpi	2	5ER8NPT2M+...	4	0.028	0.025	0.024	0.021
		1/2"	0.87	11.5	tpi	2	4ER8NPT2Z+...	4	0.028	0.025	0.024	0.021
NPT Internal	M+	3/8"	0.63	14	tpi	2	3R14NPT2M+...	3	0.020	0.018	0.017	
		1/2"	0.87	11.5	tpi	2	4R11.5NPT2M+...	4	0.018	0.017	0.017	0.016
		5/8"	1.06	11.5	tpi	2	5R11.5NPT3M+...	4	0.019	0.017	0.017	0.015
	Z+	1/2"	0.87	11.5	tpi	3	4R11.5NPT2Z+...	4	0.018	0.017	0.017	0.016
				8	tpi	2	4R8NPT2Z+...	4	0.028	0.025	0.024	0.021
		1/2"	0.87	11.5	tpi	2	4R8NPT2Z+...	4	0.028	0.025	0.024	0.021
NPTF External	M+	3/8"	0.63	14	tpi	2	3ER14NPTF2M+...	3	0.020	0.017	0.017	
NPTF Internal	M+	3/8"	0.63	14	tpi	2	3R14NPTF2M+...	3	0.020	0.017	0.017	
API BUT External	M+	5/8"	1.06	5	tpi	2	5ER5BUT752M+...	4	0.018	0.016	0.015	0.013
	T+	1/2"	0.87	5	tpi	3	4ER5BUT753T+...	3	0.022	0.02	0.020	
API BUT Internal	M+	5/8"	1.06	5	tpi	2	5R5BUT752M+...	4	0.018	0.016	0.015	0.013
	T+	1/2"	0.87	5	tpi	3	4R5BUT753T+...	3	0.022	0.020	0.020	
API RD External	M+	5/8"	1.06	10	tpi	3	5ER10APIRD3M+...	2	0.029	0.027		
				8	tpi	2	5ER8APIRD2M+...	3	0.026	0.024	0.023	
				10	tpi	6	4ER10APIRD6T+...	2	0.028	0.028		
	T+	1/2"	0.87	8	tpi	3	4ER8APIRD3T+...	2	0.037	0.035		
				8	tpi	5	4ER8APIRD5T+...	2	0.037	0.035		
				10	tpi	2	4R10APIRD2M+...	3	0.020	0.018	0.018	
API RD Internal	M+	1/2"	0.87	8	tpi	2	4R8APIRD2M+...	3	0.026	0.024	0.023	
				10	tpi	3	5R10APIRD3M+...	3	0.019	0.019	0.019	
				8	tpi	2	5R8APIRD2M+...	3	0.026	0.024	0.023	
	Z+	1/2"	0.87	8	tpi	2	4R8APIRD2Z+...	3	0.026	0.024	0.023	
				10	tpi	6	4R10APIRD6T+...	2	0.028	0.028		
				8	tpi	3	4R8APIRD3T+...	2	0.037	0.035		
T+	1/2"	0.87	8	tpi	5	4R8APIRD5T+...	2	0.037	0.035			

Thread Turning  
Technical Data



M+ Style insert



T+ Style insert



Z+ Style insert

# Step by Step Thread Turning - Example 1

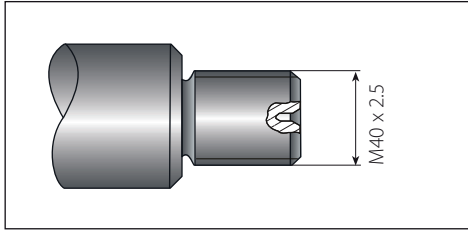

Application:  
 Thread: External Right Hand  
 1½ x 10UN  
 Material: 4140 (25 HRC)

## 1 Choose the Thread Turning Method

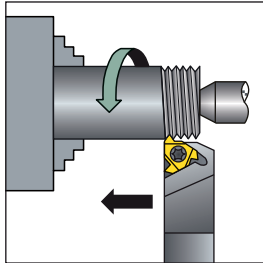

Feed direction towards the chuck was chosen.  
 Therefore, an external right hand insert and an external right hand holder will be used.

## 2 Choose the Insert Size

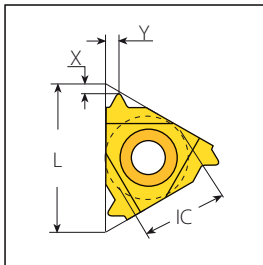

Chosen insert: 3ER10UN...

Insert Size	Pitch	Ordering Code	Anvil	Toolholder
IC	L inch	tpi	RH	RH
3/8"	0.63	10	3ER10UN...	YE3 AL..-3(LH)

## 3 Choose the Toolholder

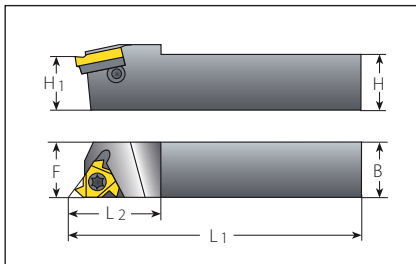

Chosen toolholder: AL 100-3

Insert Size	Ordering Code	Dimensions inch			
IC	RH	H=H1=B	F	L1	L2
3/8"	AL 100-3	1.00	1.00	6.05	1.20

## 4

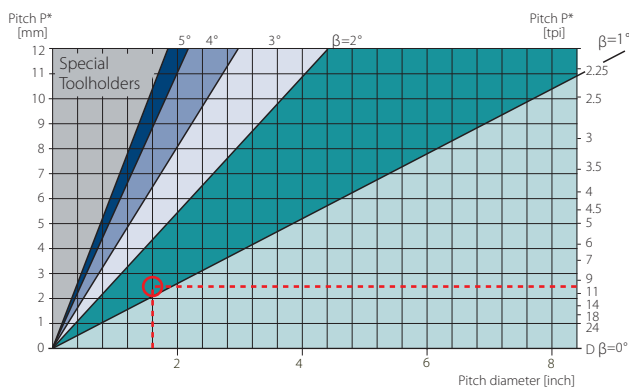

From the table, using a pitch of 10 tpi and a workpiece diameter of 1½", we find the helix angle to be 1.5°.



## 5 Choose the Correct Anvil

Anvil chosen: YE3

Insert Size		Ordering Code		Holder		Ordering Code	
IC		L inch					
3/8"	0.63	ER/IL	YE3-2P	YE3-1P	<b>YE3</b>	YE3-1N	

## 6 Choose the carbide grade and cutting speed

Carbide Grade chosen: VTX  
Cutting Speed: 420 ft/min

Material:		Hardness Brinell HB	<b>VTX</b>	VCB
<b>P</b>	Low alloy steel (alloying elements ≤ 5%)	Non hardened	180	328-590
		Hardened	275	246-459
		Hardened	350	230-443

## 7 Determine the Number of Passes

Numbers of passes: 10

### UN External

Pitch	mm	1.50	1.75	2.00	2.50	3.00	3.50	4.00
	tpi	16	14	12	<b>10</b>	8	7	6
No. of passes		6-10	7-12	7-12	<b>8-14</b>	9-16	10-18	11-18

## Summary

Thread Type	1½x10UN External Right Hand
<b>1</b> Feed Direction:	Towards the chuck
<b>2</b> Insert and Grade:	3ER10UN VTX
<b>3</b> Toolholder:	AL 100 - 3
<b>4</b> Helix Angle:	1.5°
<b>5</b> Anvil:	YE3
<b>6</b> Cutting Speed:	420 ft/min
<b>7</b> Number of Passes:	10

# Step by Step Thread Turning - Example 2

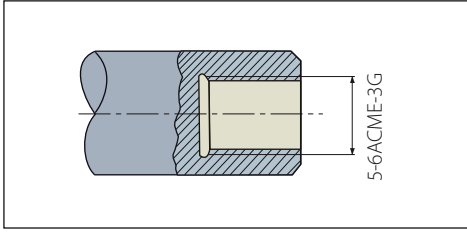

Application:  
 Thread: Internal Right Hand  
 ACME  
 Pitch: 6 tpi  
 Bore dia: 5"  
 Material: Stainless Steel Austemitic

## 1 Choose the Thread Turning Method

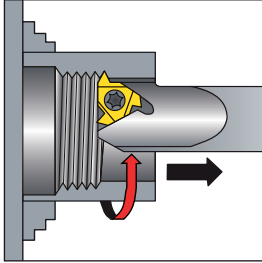

To facilitate the removal of chips from the machined area, we chose a feed direction away from the chuck. Therefore, an internal left hand insert and an internal left hand toolholder are to be used.

## 2 Choose the Insert size

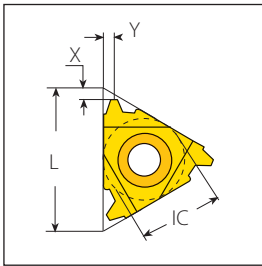

Chosen insert: 4IL6ACME

Insert Size	Pitch	Ordering Code	Anvil	Toolholder
IC	L inch	tpi	LH	LH
1/2"	0.87	6	4IL6ACME...	YE4 AVR..-4(LH)

## 3 Choose the Toolholder

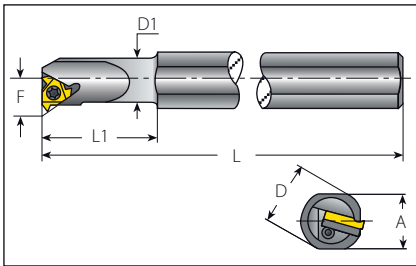

Chosen toolholder: AVR 150-4LH

Insert Size	Ordering Code	Dimensions inch						Min Bore
IC	LH	A	L	L1	D	D1	F	inch
1/2"	AVR 150-4 LH	1.34	12.00	2.50	1.50	1.50	0.98	1.75

## 4 Determine the Helix Angle

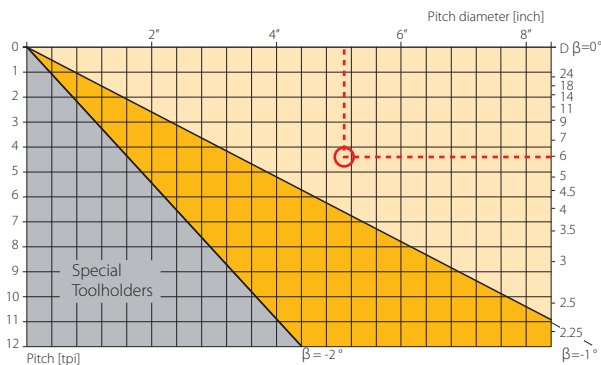

In this case, a right hand thread is being turned with a left hand toolholder. The reverse helix method is used. From the lower part of the table, using a pitch of 6 tpi and a bore diameter of 5", we obtain a helix angle of **-0.65°**.

## 5 Choose the Correct Anvil

Anvil chosen: YE4-2N

Insert Size		Ordering Code					
IC	L inch	ER/IL	YE4	YE4-1N	YE4-1.5N	YE4-2N	YE4-3N
1/2"	0.87	ER/IL	YE4	YE4-1N	YE4-1.5N	<b>YE4-2N</b>	YE4-3N

## 6 Choose the carbide grade and cutting speed

Carbide grade chosen: VTX  
Cutting speed: 420 ft/min

	Material:	Hardness Brinell HB	VTX	VCB
M	Stainless steel	Austenitic	180	295-459
	Austenitic	Super austenitic	200	131-361
				266-394
				98-328

## 7 Determine The Number Of Passes

Numbers of passes: 18

### ACME External & Internal

Pitch	mm	3.00	3.50	4.00	4.50	5.00	5.50	6.00
	tpi	8	7	<b>6</b>	5.5	5	4.5	4
No. of passes		9-16	10-18	<b>11-18</b>	11-19	12-20	12-20	12-20

## Summary

Thread Type	5"x6 ACME Internal Right Hand
<b>1</b> Feed Direction:	<b>Away from the chuck</b>
<b>2</b> Insert and Grade:	<b>4IL6ACME VTX</b>
<b>3</b> Toolholder:	<b>AVR 150-4LH</b>
<b>4</b> Helix Angle:	<b>-0.65°</b>
<b>5</b> Anvil:	<b>YE4-2N</b>
<b>6</b> Cutting Speed:	<b>420 ft/min</b>
<b>7</b> Number of Passes:	<b>18</b>

# Material Comparison Table

Material Group	Vardex No.	USA AISI/SAE	Germany W.-Nr.	Germany DIN	Great Britain BS	France AFNOR	Italy UNI
	1	1015	1.0037	St37-2	Fe360B	E24-2	Fe360 B FU
	1	1020	1.0044	St44-2	Fe430B FN	E28-2	Fe430B FN
	2	ASTM A570Gr.50	1.0050	St50-2	Fe490-2 FN	A50-2	Fe490
	2	-	1.0070	St70-2	Fe690-2 FN	A70-2	Fe690
	1	1015	1.0401	C15	080M15	CC12	C15C16
	1	1020	1.0402	C22	050A20	CC20	C20C21
	2	1035	1.0501	C35	060A35	CC35	C35
	2	1045	1.0503	C45	080M46	CC45	C45
	2	1055	1.0535	C55	070M55	-	C55
	2	1060	1.0601	C60	080A62	CC55	C60
	1	1213	1.0715	95Mn28	230M07	S250	CF95Mn28
	1	12L13	1.0718	95MnPb28	-	S250Pb	CF95MnPb28
	1	-	1.0722	105Pb20	-	10PbF2	CF10SPb20
	2	1140	1.0726	35S20	212M36	35MF4	-
	2	1215	1.0736	95Mn36	240M07	S300	CF95Mn36
	2	12L14	1.0737	95MnPb36	-	S300Pb	CF95MnPb36
	2	9255	1.0904	55Si7	250A53	55S7	55Si8
	2	9262	1.0961	60SiCr7	-	60SC7	60SiCr8
	1	1015	1.1141	Ck15	080M15	XC1 2	C16
	2	1039	1.1157	40Mn4	150M36	35M5	-
	2	1025	1.1158	Ck25	-	-	-
	2	1335	1.1167	36Mn5	-	40M5	-
	2	1330	1.1170	28Mn6	150M28	20M5	C28Mn
	2	1035	1.1183	Cf35	060A35	XC38TS	C36
	2	1045	1.1191	Ck45	080M46	XC42	C45
	2	1055	1.1203	Ck55	070M55	XC55	C50
	3	1050	1.1213	Cf53	060A52	XC48TS	C53
	3	1060	1.1221	Ck60	080A62	XC60	C60
	8	1095	1.1274	Ck101	060A96	-	-
	9	-	1.3401	X120Mn12	Z120M12	Z120M12	XG120Mn12
	8	52100	1.3505	100Cr6	534A99	100C6	100Cr6
	8	ASTM A20Gr.A	1.5415	15Mo3	1501-240	15D3	16Mo3KW
	8	4520	1.5423	16Mo5	1503-245-420	-	16Mo5
	4	ASTMA350LF5	1.5622	14Ni6	-	16N6	14Ni6
	8	ASTM A353	1.5662	X8Ni9	1501-509; 510	-	X10Ni9
	8	2515	1.5680	12Ni19	-	Z18N5	-
	5	3135	1.5710	36NiCr6	640A35	35NC6	-
	5	3415	1.5732	14NiCr10	-	14NC11	16NiCr11
	5	3415; 3310	1.5752	14NiCr14	655M13; 655M12	12NC15	-
	5	9840	1.6511	36CrNiMo4	816M40	40NCD3	38NiCrMo4(KB)
	5	8620	1.6523	21NiCrMo2	805M20	20NCD2	20NiCrMo2
	5	8740	1.6546	40NiCrMo22	311-Type7	-	40NiCrMo2(KB)
	5	4340	1.6582	34CrNiMo6	817M40	35NCD6	35NiCrMo6(KB)
	5	-	1.6587	17CrNiMo6	820A16	18NCD6	-
	5	-	1.6657	14NiCrMo134	832M13	-	15NiCrMo13
	2	5015	1.7015	15Cr3	523M15	12C3	-
	5	5132	1.7033	34Cr4	530A32	32C4	34Cr4(KB)
	5	5140	1.7035	41Cr4	530M40	42C4	41Cr4
	5	5140	1.7045	42Cr4	-	-	-
	5	5115	1.7131	16MnCr5	(527M20)	16MC5	16MnCr5
	5	5155	1.7176	55Cr3	527A60	55C3	-
	5	4130	1.7218	25CrMo4	1717CDS110	25CD4	25CrMo4(KB)
	5	4137; 4135	1.7220	34CrMo4	708A37	35CD4	35CrMo4
	5	4140; 4142	1.7223	41CrMo4	708M40	42CD4TS	41CrMo4
	5	4140	1.7225	42CrMo4	708M40	42CD4	42CrMo4
	5	-	1.7262	15CrMo5	-	12CD4	-
	5	ASTM A182; F11; F12	1.7335	13CrMo4 4	1501-620Gr.27	15CD3.5; 15CD4.5	14CrMo4 5
	5	-	1.7361	32CrMo12	722M24	30CD12	32CrMo12
	5	ASTM A182; F22	1.7380	10CrMo9 10	1501-622; Gr.31; 45	12CD9; 10	12CrMo9, 10
	5	-	1.7715	14MoV6 3	1503-660-440	-	-
	5	6150	1.8159	50CrV4	735A50	50CV4	50CrV4
	8	-	1.8509	41CrAlMo7	905M39	40CAD6, 12	41CrAlMo7
	8	-	1.8523	39CrMoV13 9	897M39	-	36CrMoV12
	5	W.110	1.1545	C105W1	-	Y1105	C98KU; C100KU
	5	W.112	1.1663	C125W	-	Y2120	C120KU
	8	L3	1.2067	100Cr6	BL3	Y100C6	-
	10	D3	1.2080	X210Cr12	BD3	Z200Cr12	X210Cr13KU
	10	-	-	-	-	-	X250Cr12KU
	10	-	1.2311	40CrMnMo7	-	-	35CrMo8KU
	10	-	1.2312	40CrMnMoS8-6	-	-	-
	10	H11	1.2343	X38CrMoV5-1	BH11	Z38CDV5	X37CrMoV51 1KU
	10	H13	1.2344	X40CrMoV5-1	BH13	Z40CDV5	X35CrMoV05KU
	10	-	-	-	-	-	X40CrMoV511KU
	10	A2	1.2363	X100CrMoV5-1	BA2	Z1 00CDV5	X100CrMoV51KU
	10	-	1.2367	X38CrMoV5-3	-	Z38CDV5-3	-
	10	D2	1.2379	X155CrVMo 12-1	BD2	Z160CDV12	X155CrVMo12 1 KU
	10	-	1.2419	105WCr6	-	105WC13	10WCr6; 107WCr5KU
	10	-	1.2436	X210CrW12	-	-	X215CrW121KU
	10	S1	1.2542	45WCrV17	BS1	-	45WCrV8KU
	10	H21	1.2581	X30WCrV9 3	BH21	Z30WCV9	X30WCrV9 3KU
	10	-	1.2601	X165CrMoV12	-	-	X165CrMoV12KU
	10	L6	1.2713	55NiCrMoV6	-	55NCDV7	-
	10	-	1.2738	40CrMnNiMo8-6-4	-	-	-
	10	W210	1.2833	100V1	BW2	Y1105V; 100V2	-
	10	-	1.3243	S 6-5-2-5	-	Z85WDCV-06-05-04-02	HS 6-5-2-5
	10	T4	1.3255	S 18-1-2-5	BT4	Z80WDCV-18-05-04-01	X78WCo1805KU
	10	M2	1.3343	S 6-5-2	BM2	Z85WDCV-06-05-04-02	X82WCo0605KU
	10	M7	1.3348	S 2-9-2	-	Z100WCVV-09-04-02-02	HS 2-9-2
	10	T1	1.3355	S 18-0-1	BT1	Z80WCV-18-04-01	X75W18KU

Thread Turning  
Technical Data

**P**  
Steel

Sweden SS	Japan JIS	Russia GOST	Spain UNE	Vardec No.
1311	STKM 12A;C	–	Fe360B	1
1412	SM400A;B;C	St4ps;sp	Fe430B FN	1
1550	SS490	St5ps;sp	A490-2	2
–	–	–	A690-2	2
1350	–	–	F.111	1
1450	–	20	1 C 22 ; F.112	1
1550	–	30	F. 113	2
1650	–	45	F.114	2
1655	–	55	F.115	2
–	–	60(G)	–	2
1912	SUM22	–	F.2111-11SMn28	1
1914	SUM22L	–	F.2112-11SMnPb28	1
–	–	–	F.2122-10SPb20	1
1957	–	–	F.210.G	2
–	–	–	F.2113-12SMn35	2
1926	–	–	F.2114-12SMnPb35	2
2085	–	55S2	F.1440-56Si7	2
–	–	–	F.1442-60SiCr8	2
1370	S15C	15	F.1110-C15k ; F.1511-C16k	1
–	–	40G	–	2
–	S25C	25	F.1120-C25k	2
2120	SMn438(H)	35G2 ; 35GL	F.1203-36Mn6 ; F.8212-36Mn5	2
–	SCM1	30G	28Mn6	2
1572	S35C	35	–	2
1672	S45C	45	F.1140-C45k ; F.1142-C48k	2
–	S55C	55	F.1150-C55k	2
1674	S50C	50	–	3
1678	S58C	60 ;60G ;60GA	–	3
1870	SUP4	–	–	8
–	SCMnH/1	110G13L	F.8251-AM-X120Mn12	9
2258	SUJ2	SchCh15	F.1310-100Cr6	8
2912	–	–	F.2601-16Mo3	8
–	–	–	F.2602-16Mo5	8
–	–	–	F.2641-15Ni6	4
–	–	–	F.2645-X8Ni09	8
–	–	–	–	8
–	SNC236	–	–	5
–	SNC415(H)	–	F.1540-15NiCr11	5
–	SNC81 5(H)	–	–	5
–	–	40ChN2MA ; 40ChGNM	F.1280-35NiCrMo4	5
2506	SNCM220(H)	20ChGNM	F.1552-20NiCrMo2 ; F.1534-20NiMo31	5
–	SNCM240	38ChGNM	F.1204-40NiCrMo2 ; F.1205-40NiCrMo2DF	5
2541	–	38Ch2N2MA	F.1272-40NiCrMo7 ;34CrNiMo6	5
–	–	–	F.1560-14NiCrMo13	5
–	–	–	F.1560-14NiCrMo13 ; F.1569-14NiCrMo131	5
–	SCr415(H)	15Ch	–	2
–	SCr430(H)	35Ch	F.8221-35Cr4	5
–	SCr440(H)	40Ch	F.1211-41Cr4DF ; F.1202-42Cr4	5
2245	SCr440	40Ch	F.1202-42Cr4	5
2511	–	18ChG	F.1516-16MnCr5 ; F.1517-16MnCr5	5
–	SUP9(A)	50ChGA	F.1431-55Cr3	5
2225	SCM420	20ChM ; 30ChM	F.8372-AM26CrMo4;F.8330-AM25CrMo4;F.1256-30CrMo4-1	5
2234	SCM432; SCCRM3	AS38ChGM;35ChM;35ChML	F.8331-AM34CrMo4;F.823134CrMo4;F.1250-35CrMo4;F.1254-35CrMo4DF	5
2244	SCM440	40ChFA	F.8332-AM42CrMo4;F.8232-42CrMo4;F.1252-40CrMo4	5
2244	SCM440(H)	–	F.8332-AM42CrMo4;F.8232-42CrMo4;F.1252-40CrMo4	5
2216	SCM415(H)	–	F.1551-12CrMo4	5
–	–	12ChM ; 15ChM	F.2631-14CrMo45	5
2240	–	–	F.124.A	5
2218	–	12Ch8	TU.H	5
–	–	–	F.2621-13MoCrV6	5
2230	SUP10	50ChGFA ; 50CHFA	F.1430-51CrV4	5
2940	–	38ChMJuA	F.1740-41CrAlMo7	8
–	–	–	–	8
1880	–	U10A-1;2	F.516	5
–	SK2	U13	F.5123 ; C120	5
–	–	Ch	F.5230 ; 100Cr6	8
–	SKD1	Ch12	F.5212 ; X210 Cr12	10
–	–	–	–	10
–	–	–	–	10
–	–	–	–	10
–	SKD6	4ChMFS	F.5317 ; X37 CrMoV5	10
2242	SKD61	4ChMF1S	F.5318 ; X40CrMoC5	10
–	–	–	–	10
2260	SKD12	–	F.5227 ; X100CrMoV5	10
–	–	–	–	10
2310	SKD11	–	F.520A	10
2140	SKS31;SKS2,SKS3	ChWG	F.5233 ; 105WCr5	10
2312	SKD2	–	F.5213 ; X210CrW12	10
2710	–	5ChW2SF	F.5241 ; 45WCrSi8	10
–	SKD5	3Ch2W8F	F.5323 ; X30WCrV9	10
2310	–	–	F.5211 ; X160CrMoV12	10
–	SKT4	5ChNM	F.520S	10
–	–	–	–	10
–	SKS43	–	–	10
2723	SKH55	2723	R6M5K5	10
–	SKH3	–	F.5530 ; 18-1-1-5	10
2722	SKH9	(R6AM5) ; R6M5	F.5603 ; 6-5-2	10
2782	–	–	F.5607 ; 18-0-1	10
–	SKH2	R18	F.5520 ; 18-0-1	10

P

# Material Comparison Table (con't)

Material Group	VardeX No.	USA AISI/SAE	Germany W.-Nr.	Germany DIN	Great Britain BS	France AFNOR	Italy UNI	
<b>M</b> Stainless Steel	12	403	1.4000	X6Cr13	403S17	Z6C13	X6Cr13	
	12	-	1.4001	X7Cr14	-	-	-	
	12	410	1.4006	X10Cr13	410S21	Z10C14	X12Cr13	
	12	430	1.4016	X6Cr17	430S15	Z8C17	X8Cr17	
	12	-	1.4027	G-X20Cr14	420C29	Z20C13M	-	
	12	-	1.4034	X46Cr13	420S45	Z40CM;Z38C13M	X40Cr14	
	12	431	1.4057	X20CrNi172	431S29	Z15CNi6.02	X16CrNi16	
	12	430	1.4104	X12CrMoS17	-	Z10CF17	X10CrS17	
	12	434	1.4113	X6CrMo171	434S17	Z8CD17.01	X8CrMo17	
	12	-	1.4313	X5CrNi134	425C11	Z4CND13.4M	-	
	12	-	1.4408	G-X6CrNiMo18 10	316C16	-	-	
	12	HW3	1.4718	X45CrSi93	401S45	Z45CS 9	X45CrSi8	
	12	405	1.4724	X10CrAl13	403S17	Z10C13	X101CrAl12	
	11	-	1.4742	X10CrAl18	430S15	Z12CAS18	X8Cr17	
	12	HNV6	1.4747	X80CrNiSi20	443S65	Z80CSN20.02	X80CrSiNi20	
	11	446	1.4762	X10CrAl24	-	Z10CAS24	X16Cr26	
	13	304	1.4301	X5CrNi18 10	304S15	Z6CN18.09	X5CrNi1810	
	13	303	1.4305	X10CrNiS18 9	303S21	Z10CNF 18.09	X10CrNiS 18.09	
	13	304L	1.4306	X2CrNi19 11	304S12;304C12	Z2CN18.10;Z3CN 19.10	X2CrNi18.11	
	13	CF8	1.4308	G-X6CrNi18 9	304C15	Z6CN18.10M	-	
	13	301	1.4310	X12CrNi177	301S21	Z12CN 17.07	X1 2CrNi1 707	
	13	304LN	1.4311	X2CrNi18 10	304S62	Z2CN18.10	-	
	13	316	1.4401	X5CrNiMo17122	316S16	Z6CND17.11	X5CrNiMo17 12	
	13	316LN	1.4429	X2CrNiMoN17133	-	Z2CND17.13	-	
	13	316L	1.4435	X2CrNiMo18143	316S12	Z2CND17.13	X2CrNiMo17 13	
	13	317L	1.4438	X2CrNiMo17133	317S12	Z2CND19.15	X2CrNiMo18 16	
	13	329	1.4460	X8CrNiMo275	-	-	-	
	12	321	1.4541	X6CrNiTi18 10	2337	Z6CNT18.10	X6CrNiTi18 11	
	12	347	1.4550	X6CrNiNb18 10	347S17	Z6CNNb18.10	X6CrNiNb18 11	
	12	316Ti	1.4571	X6CrNiMoTi17122	320S17	Z6NDT1 7.12	X6CrNiMoTi17 12	
	12	-	1.4581	G-X5CrNiMoNb18 10	318C17	Z4CNDNb18 12M	XG8CrNiMo18 11	
	12	318	1.4583	X10CrNiMoNb18 12	-	Z6CNDNb17 13B	X6CrNiMoNb17 13	
	13	309	1.4828	X15CrNiSi20 12	309S24	Z15CNS20.12	-	
	13	310S	1.4845	X12CrNi25 21	310S24	Z12CN25 20	X6CrNi25 20	
	13	330	1.4864	X12NiCr36 16	-	Z12NCS35.16	-	
	13	-	1.4865	G-X40NiCrSi38 18	330C11	-	XG50NiCr39 19	
13	EV8	1.4871	X53CrMnNiN2 19	349S54;321S12	Z52CMN21.09	X53CrMnNiN219		
13	321	1.4878	X12CrNiTi18 9	321S320	Z6CNT18.12B	X6CrNiTi1811		
<b>K</b> Cast Iron	30	No 20 B	0.6010	GG10	-	Ft 10 D	-	
	30	No 25 B	0.6015	GG15	Grade 150	Ft 15 D	-	
	30	No 30 B	0.6020	GG20	Grade 220	Ft 20 D	-	
	29	No 35 B; No 40 B	0.6025	GG25	Grade 260	Ft 25 D	-	
	29	No 45 B	0.6030	GG30	Grade 300	R 30 D	-	
	29	No 50 B	0.6035	GG35	Grade 350	Ft 35 D	-	
	29	No 55 B	0.6040	GG40	Grade 400	Ft 40 D	-	
	29	ASTM	-	DIN4694	3468; 1974	-	-	
	29	A436-72	-	GGL-	-	A32-301	-	
	29	Type 2	-	NiCr20 2	L-NiCr 20 2	L-NC 20 2	-	
	30	60-40-18	0.7040	GGG 40	SNG 420/12	FCS 400-12	GS 370-17	
	30	-	0.7043	GGG 40.3	SNG 370/17	FGS 370-17	-	
	30	-	0.7033	GGG 35.3	-	-	-	
	31	80-55-06	0.7050	GGG 50	SNG 500/7	FGS 500-7	GS 500	
	31	-	0.7060	GGG 60	SNG 600/3	FGS 600-3	-	
	31	100-70-03	0.7070	GGG70	SNG 700/2	FGS 700-2	GS 700-2	
	31	-	-	DIN 1694	-	L-NM 13 7	-	
	31	Type 2	-	GGG NiMn 13 7	L-NiMn 13 7	L-NC 20 2	-	
	31	-	-	GGG NiCr 20 2	L-NC 20 2	-	-	
	28	32510	0.8135	GTS-35	B 340/12	MN 35-10	-	
	29	40010	0.8145	GTS-45	P 440/7	-	-	
	29	50005	0.8155	GTS-55	P 510/4	MP50-5	-	
	29	70003	0.8165	GTS-65	P 570/3	MP 60-3	-	
	29	80002	0.8170	GTS-70	P690/2	MP 70-2	-	
	<b>N(K)</b> Non-Ferrous Metals	36	-	-	G-ALSi12	LM20	-	-
		36	-	-	GD-ALSi12	-	-	-
36		-	-	GD-ALSi8Cu3	LM24	-	-	
36		-	-	G-ALSi10Mg	LM9	-	-	
36		-	-	G-ALSi12	LM6	-	-	
<b>S(M)</b> Heat Resistant Material	19	330	1.4864	X12NiCrSi	-	Z12NCS35.16	-	
	19	-	1.4865	G-X40NiCrSi	330C11	-	XG50NiCr	
	19	5390 A	2.4603	-	-	NC22FeD	-	
	19	-	2.4630	NiCr20Ti	HR5, 203-4	NC20T	-	
	19	5666	2.4856	NiCr22Mo9N	-	NC22FeDNB	-	
	19	5537 C	LW2.496	CoCr20W15	-	KC20WN	-	
	19	4676	2.4375	NiCu30Al	3072-76	-	-	
	19	-	2.4631	NiCr20TiAk	Hr40,601	NC20TA	-	
	19	AMS 5399	2.4973	NiCr19Co11	-	NC19KDT	-	
	21	5391	LW2.467	S-NiCr13Al6	3146-3	NC12AD	-	
	21	5660	LW2.466	NiCr19Fe19	HR8	NC19FeNb	-	
	21	5383	LW2.466	NiCr19Fe19	-	NC20K14	-	
	21	-	-	CoCr22W14	-	KC22WN	-	
	21	-	LW2.467	NiCo15Cr10	-	-	-	
	23	-	-	TiAl14Mo4Sn4Si0.5	-	-	-	
	23	-	-	TiAl5Sn2.5	TA14/17	T-A5E	-	
	23	-	-	TiAl6V4	TA10-13/TA2	T-A6V	-	
23	-	-	TiAl6V4ELI	TA11	-	-		

Thread Turning  
Technical Data

Sweden SS	Japan JIS	Russia GOST	Spain UNE	Vardex No.		
2301	SUS403	08Ch13	F.3110-X6Cr13 ; F.8401-AM-X12Cr13	12	<b>M</b>	
-	-	08Ch13	F.3110-X6Cr13 ; F.8401-AM-X12Cr13	12		
2302	SUS410	12Ch13 ; 15Ch13L	F.3401-X10Cr13	12		
2320	SUS430	12Ch17	F.3113-X6Cr17	12		
-	SCS2	20Ch13L	-	12		
2304	SUS420J2	40Ch13	F.3405-X45Cr13	12		
2321	SUS431	20Ch17N2	F.3427-X19CrNi172	12		
2383	SUS430F	-	F.3117-X10CrS17 ; F.3413-X14CrMoS17	12		
2325	SUS434	-	F.3116-X6CrMo171	12		
-	SCS5	-	-	12		
-	SCS14	07Ch18N10G2S2M2L	F.8414-AM-X7CrNiMo2010	12		
-	SUH1	40Ch9S2	F.3220-X45CrSi09-03	12		
-	SUS405	10Ch13SJu	F.3152-X10CrAl13	12		
-	SUH21	15Ch18SJu	F.3153-X10CrAl18	11		
-	SUH4	-	F.3222-X80CrSiNi20-02	12		
2322	SUH446	-	F.3154-X10CrAl24	11		
2332	SUS304	08Ch18N10	F.3551-X5CrNi1811; F.3541-X5CrNi1810 ; F.3504-X6CrNi1910	13		
2346	SUS303	-	F.3508-X10CrNiS18-09	13		
2352	SCS19; SUS304L	03Ch18N11	F.3503-X2CrNi1810	13		
2333	SCS13	07Ch18N9L	-	13		
2331	SUS301	-	F.3517-X12CrNi177	13		
2371	SUS304LN	-	F.3541-X2CrNi1810	13		
2347	SUS316	-	F.3534-X5CrNiMo17122	13		
2375	SUS316LN	-	F.3543-X2CrNiMoN17133	13		
2353	SCS16	03Ch17N14M3	F.3533-X2CrNiMo17132	13		
2367	SUS317L	-	F.3539-X2CrNiMo18164	13		
2324	SUS329L;	-	F.3309-X8CrNiMo27-05; F.3552-X8CrNiMo266	13		
58B	SUS321	06Ch18N10T; 08Ch18N10T09; Ch18N10T; 12Ch18N10T	F.3523-X6CrNiTi1810	12		
2338	SUS347	08Ch18N12B	F.3524-X6CrNiNb1810	12		
2350	-	10Ch17N13M2T	F.3535-X6CrNiMoTi17122	12		
-	SCS22	-	-	12		
-	-	-	-	12		
-	SUH309	20Ch20N14S2	F.3312-X15CrNiSi20-12	13		
2361	SUH310	20Ch23N18	-	13		
-	SUH330	-	F.3313-X12CrNiSi36-16	13		
-	SCH15	-	-	13		
-	SUH35,SUH36,SU321	55Ch20G9AN4	F.3217-X53CrMnNiN21-09	13		
-	-	-	-	13		
01 10	-	C410	FG10	30		<b>K</b>
01 15	-	C415	FG15	30		
01 20	-	C420	FG20	30		
01 25	-	C425	FG25	29		
01 30	-	C430	FG30	29		
01 35	-	C435	FG35	29		
01 40	-	C440	-	29		
MB	-	-	-	29		
ISO-215	-	-	-	29		
523	-	-	-	29		
07 17-02	-	VC42-12	-	30		
07 17-12	-	VC42-12	-	30		
07 17-15	-	-	-	30		
07 27-02	-	VC50-2	-	31		
07 32-03	-	VC60-2	-	31		
07 37-01	-	VC70-2	-	31		
07 72	-	-	-	31		
07 76	-	-	-	31		
-	-	-	-	31		
08 15	-	-	-	28		
08 52	-	-	-	29		
08 54	-	-	-	29		
08 58	-	-	-	29		
08 62	-	-	-	29		
4260	-	-	-	36		
4247	-	-	-	36		
4250	-	-	-	36		
4253	-	-	-	36		
4261	-	-	-	36		
-	SUH 330	-	F.3313-X12CrNiSi36-16	19	<b>N</b>	
-	SCH 15	-	-	19		
-	-	-	-	19		
-	-	-	-	19		
-	-	-	-	19		
-	-	-	-	19		
-	-	-	-	19		
-	-	-	-	19		
-	-	-	-	19		
-	-	-	-	19		
-	-	-	-	19		
-	-	-	-	19		
-	-	-	-	19		
-	-	-	-	19		
-	-	-	-	19		
-	-	-	-	19		
-	-	-	-	21	<b>S</b>	
-	-	-	-	21		
-	-	-	-	21		
-	-	-	-	21		
-	-	-	-	21		
-	-	-	-	21		
-	-	-	-	21		
-	-	-	-	21		
-	-	-	-	21		
-	-	-	-	21		
-	-	-	-	23		
-	-	-	-	23		
-	-	-	-	23		
-	-	-	-	23		
-	-	-	-	23		

# Troubleshooting

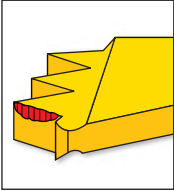
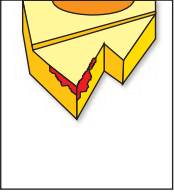
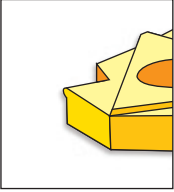
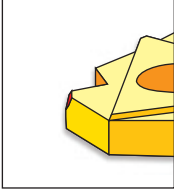
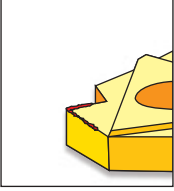
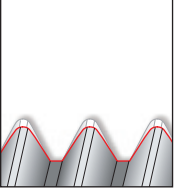
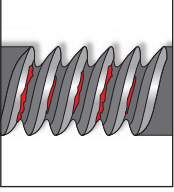
	Problem	Possible Cause	Solution
	Increased flank wear	Cutting speed too high -----> Depth of cut too low/ too many passes -----> Unsuitable carbide grade -----> Insufficient cooling ----->	Reduce cutting speed/ use coated insert Increase the depth of cut per pass Use a coated carbide grade Increase coolant flow rate
	Uneven cutting edge wear	Incorrect helix angle -----> Wrong infeed method ----->	Choose the correct anvil Use the alternating flank infeed method
	Extreme plastic deformation	Depth of cut too large -----> Insufficient cooling -----> Cutting speed too high -----> Unsuitable carbide grade -----> Nose radius too small ----->	Decrease depth of cut/ increase number of passes Increase coolant flow rate Reduce cutting speed Use a tougher carbide Use an insert with a larger radius, if possible
	Cutting edge breakage	Depth of cut too large -----> Extreme plastic deformation -----> Insufficient cooling -----> Unsuitable carbide grade -----> Instability ----->	Decrease depth of cut/ increase number of passes Use a tougher carbide Increase flow rate and/ or correct flow direction Use a tougher carbide Check stability of the system
	Built-up edge	Incorrect cutting speed -----> Unsuitable carbide grade ----->	Change the cutting speed Use a coated carbide
	Thread profile is too shallow	The tool is not at the workpiece axis height ---> Insert is not machining the thread crest -----> Worn insert ----->	Change tool height Measure the workpiece diameter Change the cutting edge sooner
	Poor surface quality	Cutting speed too low -----> Wrong anvil -----> Flank infeed method is not appropriat ----->	Increase cutting speed Choose correct anvil Use the alternate flank or radial infeed method