

PROVEN SOLUTIONS | ALWAYS AVAILABLE

ALL-STAR

AMERICAS | VOL 1

HOLEMAKING



COMPLETE
METALWORKING
SOLUTIONS

(800) 991-4225

www.ahbinc.com

ISO Certified

customerservice@ahbinc.com

WIDIA

The All-Star Program reinforces the core qualities of the WIDIA™ diamond — providing proven solutions that are easy to find and always available.

With All-Star, customers can benefit from product reliability and quick delivery to increase machine utilization.



 ALL-STAR



PROVEN SOLUTIONS

Products included in the All-Star program were chosen based on their proven performance and popularity. These industry-leading solutions combine versatility and productivity to deliver savings.



EASY TO FIND

It is easy to recommend All-Star on-the-go or in the shop while using tools like the NOVO™ tool advisor or the Machining Central app. To view All-Star products on widia.com, use the All-Star filter.



Available to download in the app store!

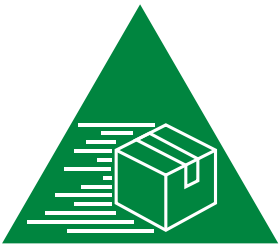

ALWAYS AVAILABLE

All-Star products are held to the highest availability standards. This means products that are flagged as All-Star feature same-day shipping for all orders received before 6pm EST.

TO SEE ALL PRODUCTS LINES, VISIT OUR DIGITAL RESOURCES



WIDIA NOVO™ Application
Download to your desktop or tablet:
widia.com/novo



WIDIA™ Machining Central Mobile App
Download for iOS or Android:
widia.com/en/featured/WidiaMobileApp

HOLEMAKING

SOLID CARBIDE DRILLS

Pages C4–C14

VarDrill™ — Best Price Performance Ratio



MODULAR DRILLS

Pages C16–C25

TOP DRILL™ Modular X (TDMX) — Extra-Stable Modular Drill

TOP DRILL M1™ (TDM1) — Versatile Modular Drilling System





INDEXABLE DRILLS

Pages C26–C37

Top Cut 4™ — Next Generation Indexable Drill

TO SEE ALL PRODUCTS LINES, VISIT OUR DIGITAL RESOURCES



WIDIA NOVO™ Application
Download to your desktop or tablet:
widia.com/novo



WIDIA™ Machining Central Mobile App
Download for iOS or Android:
widia.com/en/featured/WidiaMobileApp

SOLID CARBIDE DRILLS

VariDrill™

Pages C6–C14

VariDrill is a technologically advanced holemaking solution. These high-performance solid carbide drills were designed in Germany to provide the transportation, aerospace, general engineering, and energy industries with a tool that performs on multiple materials.





TDMX

VariDrill™

WIDIA provides a growing portfolio of drilling solutions to machine steels, stainless steels, cast iron and high-temp alloys to create components for the energy industry.

TO SEE ALL PRODUCTS LINES, VISIT OUR DIGITAL RESOURCES



WIDIA NOVO™ Application
Download to your desktop or tablet:
widia.com/novo



WIDIA™ Machining Central Mobile App
Download for iOS or Android:
widia.com/en/featured/WidiaMobileApp

The VariDrill advanced-point geometry design offers the ultimate solution for multipurpose drilling operations. It offers dependable tool life in all materials due to less chipping on the cutting edge.

- Reduced chipping on cutting edge means longer tool life.
- Geometry design offers strength and versatility.
- Delivers proper surface finish across multiple materials:
Steel, stainless steel, cast iron, aluminum, and high-temp alloys.

Materials:



Lengths

Available with and without through coolant channels.



Diameter Range

.039–.787"



VDS201A • VDS401A • 3 x D

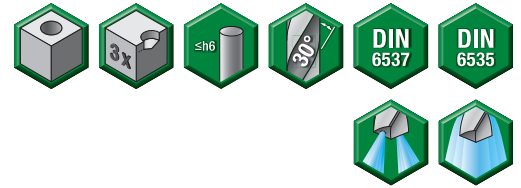
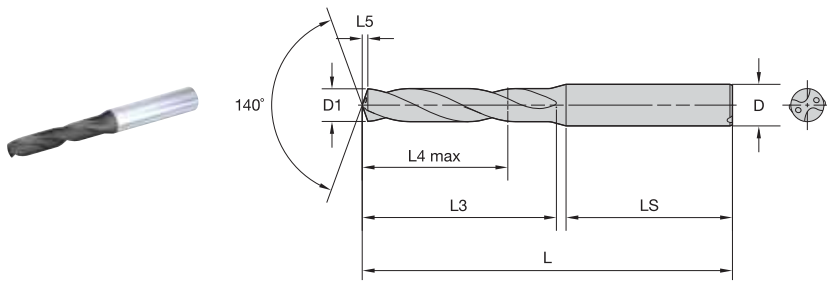

● first choice
○ alternate choice

P	●
M	●
K	●
N	●
S	●
H	

catalog number	D1 diameter				L4 max	L3	L5	L	LS	D	CF	WU25PD
	mm	in	fraction	wire size								
VDS201A01500	1,500	.0591	—	—	6	9	0,2	58	28	4	e	4144528
VDS401A01600	1,600	.0630	—	—	6	9	0,2	58	28	4	i	4140271
VDS201A01800	1,800	.0709	—	—	6	9	0,3	58	28	4	e	4144531
VDS401A01900	1,900	.0748	—	—	6	9	0,3	58	28	4	i	4140424
VDS201A02000	2,000	.0787	—	—	10	13	0,3	58	28	4	e	4144534
VDS401A02000	2,000	.0787	—	—	10	13	0,3	58	28	4	i	4140426
VDS201A02100	2,100	.0827	—	—	10	13	0,3	58	28	4	e	4144535
VDS401A02100	2,100	.0827	—	—	10	13	0,3	58	28	4	i	4140427
VDS201A02200	2,200	.0866	—	—	10	13	0,3	58	28	4	e	4144536
VDS401A02300	2,300	.0906	—	—	10	13	0,4	58	28	4	i	4140429
VDS201A02383	2,383	.0938	3/32	—	12	17	0,4	58	28	4	e	4144538
VDS401A02383	2,383	.0938	3/32	—	12	17	0,4	58	28	4	i	4140430
VDS201A02439	2,439	.0960	—	41	12	17	0,4	58	28	4	e	4144540
VDS201A02489	2,489	.0980	—	40	12	17	0,4	58	28	4	e	4144541
VDS401A02489	2,489	.0980	—	40	12	17	0,4	58	28	4	i	4140433
VDS401A02500	2,500	.0984	—	—	12	17	0,4	58	28	4	i	4140434
VDS201A02578	2,578	.1015	—	38	12	17	0,4	58	28	4	e	4144543
VDS401A02578	2,578	.1015	—	38	12	17	0,4	58	28	4	i	4140435
VDS201A02600	2,600	.1024	—	—	12	17	0,4	58	28	4	e	4144544
VDS201A02642	2,642	.1040	—	37	12	17	0,4	58	28	4	e	4144545
VDS401A02700	2,700	.1063	—	—	12	17	0,4	58	28	4	i	4140438
VDS201A02705	2,705	.1065	—	36	12	17	0,4	58	28	4	e	4144547
VDS201A02800	2,800	.1102	—	—	12	17	0,5	58	28	4	e	4144549
VDS401A02800	2,800	.1102	—	—	12	17	0,5	58	28	4	i	4140441
VDS201A02870	2,870	.1130	—	33	12	17	0,5	58	28	4	e	4144551
VDS201A03000	3,000	.1181	—	—	14	20	0,5	62	36	6	e	4143907
VDS401A03000	3,000	.1181	—	—	14	20	0,5	62	36	6	i	4140299
VDS201A03100	3,100	.1220	—	—	14	20	0,5	62	36	6	e	4143909
VDS401A03100	3,100	.1220	—	—	14	20	0,5	62	36	6	i	4140301
VDS201A03175	3,175	.1250	1/8	—	14	20	0,5	62	36	6	e	4143910
VDS401A03175	3,175	.1250	1/8	—	14	20	0,5	62	36	6	i	4140302
VDS201A03200	3,200	.1260	—	—	14	20	0,5	62	36	6	e	4143911
VDS201A03264	3,264	.1285	—	30	14	20	0,5	62	36	6	e	4143912
VDS401A03264	3,264	.1285	—	30	14	20	0,5	62	36	6	i	4140304
VDS201A03300	3,300	.1299	—	—	14	20	0,5	62	36	6	e	4143913
VDS401A03300	3,300	.1299	—	—	14	20	0,5	62	36	6	i	4140305
VDS401A03400	3,400	.1339	—	—	14	20	0,6	62	36	6	i	4140306
VDS201A03455	3,455	.1360	—	29	14	20	0,6	62	36	6	e	4143915
VDS201A03500	3,500	.1378	—	—	14	20	0,6	62	36	6	e	4143916
VDS401A03571	3,571	.1406	9/64	—	14	20	0,6	62	36	6	i	4140309
VDS201A03600	3,600	.1417	—	—	14	20	0,6	62	36	6	e	4143918
VDS201A03700	3,700	.1457	—	—	14	20	0,6	62	36	6	e	4143920
VDS201A03800	3,800	.1496	—	—	17	24	0,6	66	36	6	e	4143922
VDS401A03800	3,800	.1496	—	—	17	24	0,6	66	36	6	i	4140314
VDS201A03900	3,900	.1535	—	—	17	24	0,6	66	36	6	e	4143923
VDS201A03970	3,970	.1563	5/32	—	17	24	0,7	66	36	6	e	4143924
VDS401A03970	3,970	.1563	5/32	—	17	24	0,7	66	36	6	i	4140316
VDS201A04000	4,000	.1575	—	—	17	24	0,7	66	36	6	e	4143925
VDS401A04000	4,000	.1575	—	—	17	24	0,7	66	36	6	i	4140317
VDS201A04039	4,039	.1590	—	21	17	24	0,7	66	36	6	e	4143926
VDS401A04039	4,039	.1590	—	21	17	24	0,7	66	36	6	i	4140318
VDS201A04090	4,090	.1610	—	20	17	24	0,7	66	36	6	e	4143927
VDS201A04100	4,100	.1614	—	—	17	24	0,7	66	36	6	e	4143928
VDS401A04100	4,100	.1614	—	—	17	24	0,7	66	36	6	i	4140320
VDS201A04200	4,200	.1654	—	—	17	24	0,7	66	36	6	e	4143929
VDS201A04217	4,217	.1660	—	19	17	24	0,7	66	36	6	e	4143930

VDS201A • VDS401A • 3 x D

(continued)

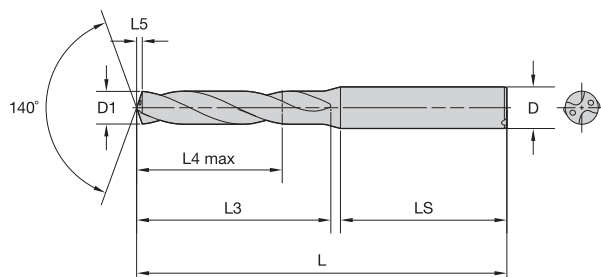

- first choice
- alternate choice

P	●
M	●
K	●
N	●
S	●
H	●

catalog number	D1 diameter			wire size	L4 max	L3	L5	L	LS	D	CF	WU25PD
	mm	in	fraction									
VDS201A04300	4,300	.1693	—	—	17	24	0,7	66	36	6	e	4143931
VDS401A04300	4,300	.1693	—	—	17	24	0,7	66	36	6	i	4140323
VDS201A04366	4,366	.1719	11/64	—	17	24	0,7	66	36	6	e	4143932
VDS401A04366	4,366	.1719	11/64	—	17	24	0,7	66	36	6	i	4140324
VDS201A04400	4,400	.1732	—	—	17	24	0,7	66	36	6	e	4143933
VDS201A04500	4,500	.1772	—	—	17	24	0,7	66	36	6	e	4143934
VDS201A04600	4,600	.1811	—	—	17	24	0,8	66	36	6	e	4143935
VDS401A04600	4,600	.1811	—	—	17	24	0,8	66	36	6	i	4140328
VDS201A04763	4,763	.1875	3/16	—	20	28	0,8	66	36	6	e	4143938
VDS401A04763	4,763	.1875	3/16	—	20	28	0,8	66	36	6	i	4140331
VDS201A04800	4,800	.1890	—	12	20	28	0,8	66	36	6	e	4143939
VDS401A04800	4,800	.1890	—	12	20	28	0,8	66	36	6	i	4140332
VDS401A04852	4,852	.1910	—	11	20	28	0,8	66	36	6	i	4140333
VDS401A04900	4,900	.1929	—	—	20	28	0,8	66	36	6	i	4140334
VDS201A05000	5,000	.1969	—	—	20	28	0,8	66	36	6	e	4143942
VDS401A05000	5,000	.1969	—	—	20	28	0,8	66	36	6	i	4140335
VDS201A05100	5,100	.2008	—	—	20	28	0,9	66	36	6	e	4143943
VDS401A05100	5,100	.2008	—	—	20	28	0,9	66	36	6	i	4140336
VDS201A05159	5,159	.2031	13/64	—	20	28	0,9	66	36	6	e	4143945
VDS401A05200	5,200	.2047	—	—	20	28	0,9	66	36	6	i	4140339
VDS201A05400	5,400	.2126	—	—	20	28	0,9	66	36	6	e	4143948
VDS201A05410	5,410	.2130	—	3	20	28	0,9	66	36	6	e	4143949
VDS401A05410	5,410	.2130	—	3	20	28	0,9	66	36	6	i	4140342
VDS201A05500	5,500	.2165	—	—	20	28	0,9	66	36	6	e	4143950
VDS201A05558	5,558	.2188	7/32	—	20	28	0,9	66	36	6	e	4143951
VDS201A05600	5,600	.2205	—	—	20	28	0,9	66	36	6	e	4143952
VDS401A05600	5,600	.2205	—	—	20	28	0,9	66	36	6	i	4140345
VDS401A05800	5,800	.2283	—	—	20	28	1,0	66	36	6	i	4140348
VDS201A05954	5,954	.2344	15/64	—	20	28	1,0	66	36	6	e	4143957
VDS401A05954	5,954	.2344	15/64	—	20	28	1,0	66	36	6	i	4140350
VDS401A06000	6,000	.2362	—	—	20	28	1,0	66	36	6	i	4140351
VDS201A06100	6,100	.2402	—	—	24	34	1,0	79	36	8	e	4143959
VDS401A06100	6,100	.2402	—	—	24	34	1,0	79	36	8	i	4140352
VDS201A06200	6,200	.2441	—	—	24	34	1,0	79	36	8	e	4143960
VDS401A06200	6,200	.2441	—	—	24	34	1,0	79	36	8	i	4140353
VDS201A06350	6,350	.2500	1/4	E	24	34	1,1	79	36	8	e	4143962
VDS401A06350	6,350	.2500	1/4	E	24	34	1,1	79	36	8	i	4140355
VDS201A06400	6,400	.2520	—	—	24	34	1,1	79	36	8	e	4143963
VDS401A06400	6,400	.2520	—	—	24	34	1,1	79	36	8	i	4140356
VDS201A06500	6,500	.2559	—	—	24	34	1,1	79	36	8	e	4143964
VDS401A06500	6,500	.2559	—	—	24	34	1,1	79	36	8	i	4140357
VDS201A06528	6,528	.2570	—	F	24	34	1,1	79	36	8	e	4143965
VDS401A06528	6,528	.2570	—	F	24	34	1,1	79	36	8	i	4140358
VDS401A06600	6,600	.2598	—	—	24	34	1,1	79	36	8	i	4140359
VDS401A06630	6,630	.2610	—	G	24	34	1,1	79	36	8	i	4140360
VDS201A06700	6,700	.2638	—	—	24	34	1,1	79	36	8	e	4143968
VDS401A06700	6,700	.2638	—	—	24	34	1,1	79	36	8	i	4140361
VDS201A06746	6,746	.2656	17/64	—	24	34	1,1	79	36	8	e	4143969
VDS401A06746	6,746	.2656	17/64	—	24	34	1,1	79	36	8	i	4140362
VDS201A06800	6,800	.2677	—	—	24	34	1,1	79	36	8	e	4143970
VDS401A06800	6,800	.2677	—	—	24	34	1,1	79	36	8	i	4140363
VDS401A06900	6,900	.2717	—	—	24	34	1,2	79	36	8	i	4140364
VDS201A07000	7,000	.2756	—	—	24	34	1,2	79	36	8	e	4143972
VDS401A07000	7,000	.2756	—	—	24	34	1,2	79	36	8	i	4140365
VDS201A07145	7,145	.2813	9/32	—	29	41	1,2	79	36	8	e	4143974
VDS401A07145	7,145	.2813	9/32	—	29	41	1,2	79	36	8	i	4140367
VDS201A07200	7,200	.2835	—	—	29	41	1,2	79	36	8	e	4143975
VDS201A07300	7,300	.2874	—	—	29	41	1,2	79	36	8	e	4143976
VDS201A07400	7,400	.2913	—	—	29	41	1,3	79	36	8	e	4143977
VDS401A07400	7,400	.2913	—	—	29	41	1,3	79	36	8	i	4140370
VDS201A07541	7,541	.2969	19/64	—	29	41	1,3	79	36	8	e	4143979
VDS201A07600	7,600	.2992	—	—	29	41	1,3	79	36	8	e	4143980
VDS401A07600	7,600	.2992	—	—	29	41	1,3	79	36	8	i	4140373
VDS201A07700	7,700	.3031	—	—	29	41	1,3	79	36	8	e	4143981

VDS201A • VDS401A • 3 x D

(continued)

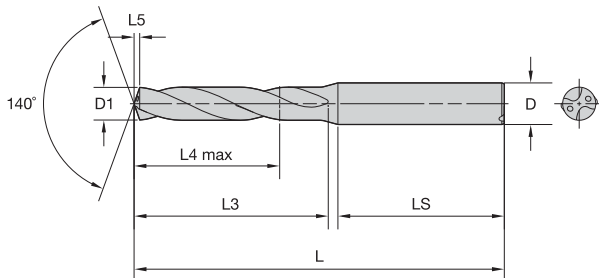

- first choice
- alternate choice

P	●
M	●
K	●
N	●
S	●
H	●

catalog number	D1 diameter				L4 max	L3	L5	L	LS	D	CF	WU25PD
	mm	in	fraction	wire size								
VDS201A07938	7,938	.3125	5/16	—	29	41	1,3	79	36	8	e	4143984
VDS401A07938	7,938	.3125	5/16	—	29	41	1,3	79	36	8	i	4140377
VDS201A08000	8,000	.3150	—	—	29	41	1,4	79	36	8	e	4143985
VDS401A08100	8,100	.3189	—	—	35	47	1,4	89	40	10	i	4140379
VDS401A08200	8,200	.3228	—	—	35	47	1,4	89	40	10	i	4140380
VDS201A08334	8,334	.3281	21/64	—	35	47	1,4	89	40	10	e	4143989
VDS401A08334	8,334	.3281	21/64	—	35	47	1,4	89	40	10	i	4140382
VDS201A08433	8,433	.3320	—	Q	35	47	1,4	89	40	10	e	4143991
VDS201A08500	8,500	.3346	—	—	35	47	1,4	89	40	10	e	4143992
VDS401A08500	8,500	.3346	—	—	35	47	1,4	89	40	10	i	4140385
VDS201A08733	8,733	.3438	11/32	—	35	47	1,5	89	40	10	e	4143995
VDS401A08733	8,733	.3438	11/32	—	35	47	1,5	89	40	10	i	4140388
VDS201A08800	8,800	.3465	—	—	35	47	1,5	89	40	10	i	4140389
VDS401A09000	9,000	.3543	—	—	35	47	1,5	89	40	10	i	4140391
VDS201A09129	9,129	.3594	23/64	—	35	47	1,6	89	40	10	e	4144000
VDS201A09347	9,347	.3680	—	U	35	47	1,6	89	40	10	e	4144003
VDS201A09525	9,525	.3750	3/8	—	35	47	1,6	89	40	10	e	4144006
VDS401A09525	9,525	.3750	3/8	—	35	47	1,6	89	40	10	i	4140399
VDS201A09800	9,800	.3858	—	—	35	47	1,7	89	40	10	e	4144009
VDS401A09800	9,800	.3858	—	—	35	47	1,7	89	40	10	i	4140402
VDS201A09921	9,921	.3906	25/64	—	35	47	1,7	89	40	10	e	4144011
VDS401A09921	9,921	.3906	25/64	—	35	47	1,7	89	40	10	i	4140404
VDS201A10000	10,000	.3937	—	—	35	47	1,7	89	40	10	e	4144172
VDS401A10100	10,100	.3976	—	—	40	55	1,7	102	45	12	i	4140002
VDS201A10200	10,200	.4016	—	—	40	55	1,7	102	45	12	e	4144424
VDS401A10200	10,200	.4016	—	—	40	55	1,7	102	45	12	i	4140163
VDS201A10320	10,320	.4063	13/32	—	40	55	1,8	102	45	12	e	4144426
VDS401A10320	10,320	.4063	13/32	—	40	55	1,8	102	45	12	i	4140165
VDS401A10500	10,500	.4134	—	—	40	55	1,8	102	45	12	i	4140167
VDS201A10600	10,600	.4173	—	—	40	55	1,8	102	45	12	e	4144429
VDS201A10716	10,716	.4219	27/64	—	40	55	1,8	102	45	12	e	4144431
VDS401A10716	10,716	.4219	27/64	—	40	55	1,8	102	45	12	i	4140170
VDS201A11000	11,000	.4331	—	—	40	55	1,9	102	45	12	e	4144434
VDS201A11113	11,113	.4375	7/16	—	40	55	1,9	102	45	12	e	4144436
VDS401A11113	11,113	.4375	7/16	—	40	55	1,9	102	45	12	i	4140175
VDS201A11509	11,509	.4531	29/64	—	40	55	2,0	102	45	12	e	4144441
VDS401A11509	11,509	.4531	29/64	—	40	55	2,0	102	45	12	i	4140180
VDS201A11908	11,908	.4688	15/32	—	40	55	2,0	102	45	12	e	4144446
VDS201A12000	12,000	.4724	—	—	40	55	2,1	102	45	12	e	4144447
VDS201A12304	12,304	.4844	31/64	—	43	60	2,1	107	45	14	e	4144451
VDS401A12304	12,304	.4844	31/64	—	43	60	2,1	107	45	14	i	4140190
VDS201A12700	12,700	.5000	1/2	—	43	60	2,2	107	45	14	e	4144455
VDS401A12700	12,700	.5000	1/2	—	43	60	2,2	107	45	14	i	4140195
VDS401A13000	13,000	.5118	—	—	43	60	2,2	107	45	14	i	4140198
VDS201A13500	13,500	.5315	—	—	43	60	2,3	107	45	14	e	4144464
VDS401A13500	13,500	.5315	—	—	43	60	2,3	107	45	14	i	4140204
VDS201A14000	14,000	.5512	—	—	43	60	2,4	107	45	14	e	4144470
VDS201A14288	14,288	.5625	9/16	—	45	65	2,5	115	48	16	e	4144473
VDS401A14288	14,288	.5625	9/16	—	45	65	2,5	115	48	16	i	4140213
VDS401A14500	14,500	.5709	—	—	45	65	2,5	115	48	16	i	4140216
VDS201A15000	15,000	.5906	—	—	45	65	2,6	115	48	16	e	4144482
VDS201A15600	15,600	.6142	—	—	45	65	2,7	115	48	16	e	4144490
VDS201A15875	15,875	.6250	5/8	—	45	65	2,8	115	48	16	e	4144493
VDS201A16000	16,000	.6299	—	—	45	65	2,8	115	48	16	e	4144495
VDS201A17463	17,463	.6875	11/16	—	51	73	3,0	123	48	18	e	4144513
VDS201A17600	17,600	.6929	—	—	51	73	3,1	123	48	18	e	4144515
VDS201A17859	17,859	.7031	45/64	—	51	73	3,1	123	48	18	e	4144518
VDS201A19050	19,050	.7500	3/4	—	55	79	3,3	131	50	20	e	4144603

NOTE: CF = Coolant Feature:
 i = internal
 e = external
 i/e = internal and external

VDS202A • VDS402A • 5 x D

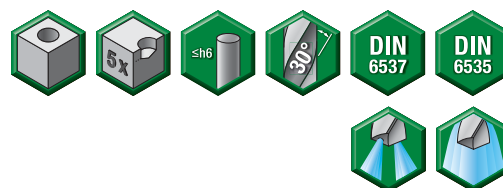
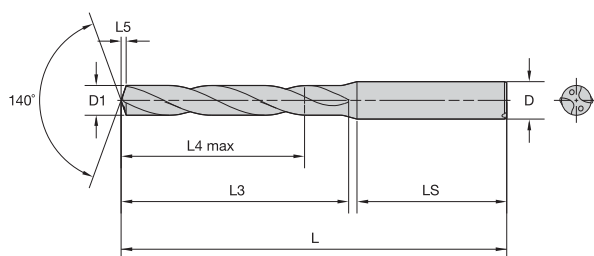

● first choice
○ alternate choice

P	●
M	●
K	●
N	●
S	●
H	●

catalog number	D1 diameter				L4 max	L3	L5	L	LS	D	CF	WU25PD
	mm	in	fraction	wire size								
VDS202A01500	1,500	.0591	—	—	9	12	0,2	58	28	4	e	4148013
VDS202A01700	1,700	.0669	—	—	9	12	0,3	58	28	4	e	4148015
VDS202A01984	1,984	.0781	5/64	—	14	18	0,3	58	28	4	e	4148018
VDS202A02383	2,383	.0938	3/32	—	17	22	0,4	58	28	4	e	4148023
VDS402A02383	2,383	.0938	3/32	—	17	22	0,4	58	28	4	i	4142911
VDS202A02439	2,439	.0960	—	41	17	22	0,4	58	28	4	e	4148025
VDS402A02439	2,439	.0960	—	41	17	22	0,4	58	28	4	i	4142927
VDS202A02489	2,489	.0980	—	40	17	22	0,4	58	28	4	e	4148026
VDS402A02578	2,578	.1015	—	38	17	22	0,4	58	28	4	i	4142936
VDS402A02642	2,642	.1040	—	37	17	22	0,4	58	28	4	i	4142942
VDS402A02700	2,700	.1063	—	—	17	22	0,4	58	28	4	i	4142945
VDS202A02779	2,779	.1094	7/64	—	17	22	0,4	58	28	4	e	4148033
VDS402A02779	2,779	.1094	7/64	—	17	22	0,4	58	28	4	i	4142951
VDS402A03000	3,000	.1181	—	—	23	28	0,5	66	36	6	i	4142844
VDS202A03048	3,048	.1200	—	31	23	28	0,5	66	36	6	e	4148143
VDS402A03048	3,048	.1200	—	31	23	28	0,5	66	36	6	i	4142846
VDS202A03175	3,175	.1250	1/8	—	23	28	0,5	66	36	6	e	4148145
VDS402A03175	3,175	.1250	1/8	—	23	28	0,5	66	36	6	i	4142849
VDS402A03200	3,200	.1260	—	—	23	28	0,5	66	36	6	i	4142851
VDS202A03264	3,264	.1285	—	30	23	28	0,5	66	36	6	e	4148147
VDS402A03300	3,300	.1299	—	—	23	28	0,5	66	36	6	i	4142865
VDS202A03400	3,400	.1339	—	—	23	28	0,6	66	36	6	e	4148149
VDS402A03455	3,455	.1360	—	29	23	28	0,6	66	36	6	i	4142869
VDS402A03571	3,571	.1406	9/64	—	23	28	0,6	66	36	6	i	4142885
VDS202A03600	3,600	.1417	—	—	23	28	0,6	66	36	6	e	4148153
VDS402A03658	3,658	.1440	—	27	23	28	0,6	66	36	6	i	4142891
VDS202A03700	3,700	.1457	—	—	23	28	0,6	66	36	6	e	4148155
VDS402A03800	3,800	.1496	—	—	29	36	0,6	74	36	6	i	4142900
VDS402A03900	3,900	.1535	—	—	29	36	0,6	74	36	6	i	4142903
VDS202A03970	3,970	.1563	5/32	—	29	36	0,7	74	36	6	e	4148159
VDS402A03970	3,970	.1563	5/32	—	29	36	0,7	74	36	6	i	4142906
VDS402A04000	4,000	.1575	—	—	29	36	0,7	74	36	6	i	4142909
VDS402A04039	4,039	.1590	—	21	29	36	0,7	74	36	6	i	4142912
VDS202A04090	4,090	.1610	—	20	29	36	0,7	74	36	6	e	4148162
VDS202A04100	4,100	.1614	—	—	29	36	0,7	74	36	6	e	4148163
VDS402A04100	4,100	.1614	—	—	29	36	0,7	74	36	6	i	4142928
VDS402A04200	4,200	.1654	—	—	29	36	0,7	74	36	6	i	4142931
VDS202A04217	4,217	.1660	—	19	29	36	0,7	74	36	6	e	4148165
VDS402A04300	4,300	.1693	—	—	29	36	0,7	74	36	6	i	4142937
VDS402A04366	4,366	.1719	11/64	—	29	36	0,7	74	36	6	i	4142940
VDS202A04400	4,400	.1732	—	—	29	36	0,7	74	36	6	e	4148168
VDS202A04500	4,500	.1772	—	—	29	36	0,7	74	36	6	e	4148169
VDS402A04500	4,500	.1772	—	—	29	36	0,7	74	36	6	i	4142946
VDS202A04763	4,763	.1875	3/16	—	35	44	0,8	82	36	6	e	4148173
VDS402A04763	4,763	.1875	3/16	—	35	44	0,8	82	36	6	i	4142968
VDS402A04800	4,800	.1890	—	12	35	44	0,8	82	36	6	i	4142971
VDS402A04852	4,852	.1910	—	11	35	44	0,8	82	36	6	i	4142974
VDS202A05000	5,000	.1969	—	—	35	44	0,8	82	36	6	e	4148177
VDS402A05000	5,000	.1969	—	—	35	44	0,8	82	36	6	i	4142979
VDS202A05100	5,100	.2008	—	—	35	44	0,9	82	36	6	e	4148178
VDS402A05100	5,100	.2008	—	—	35	44	0,9	82	36	6	i	4142981
VDS202A05106	5,106	.2010	—	7	35	44	0,9	82	36	6	e	4148179
VDS402A05106	5,106	.2010	—	7	35	44	0,9	82	36	6	i	4142994
VDS202A05159	5,159	.2031	13/64	—	35	44	0,9	82	36	6	e	4148180
VDS402A05159	5,159	.2031	13/64	—	35	44	0,9	82	36	6	i	4142996
VDS202A05200	5,200	.2047	—	—	35	44	0,9	82	36	6	e	4148181

VDS202A • VDS402A • 5 x D

(continued)

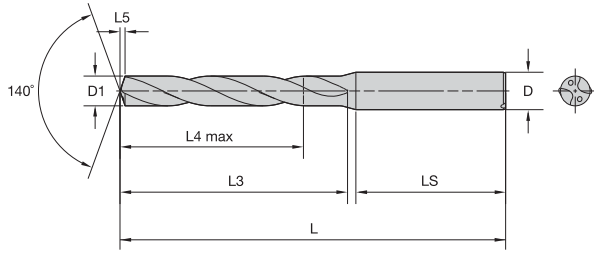

- first choice
- alternate choice

P	●
M	●
K	●
N	●
S	●
H	●

catalog number	D1 diameter				L4 max	L3	L5	L	LS	D	CF	WU25PD
	mm	in	fraction	wire size								
VDS402A05200	5,200	.2047	—	—	35	44	0,9	82	36	6	i	4142997
VDS202A05300	5,300	.2087	—	—	35	44	0,9	82	36	6	e	4148182
VDS202A05400	5,400	.2126	—	—	35	44	0,9	82	36	6	e	4148183
VDS202A05410	5,410	.2130	—	3	35	44	0,9	82	36	6	e	4148184
VDS402A05500	5,500	.2165	—	—	35	44	0,9	82	36	6	i	4143002
VDS202A05558	5,558	.2188	7/32	—	35	44	0,9	82	36	6	e	4148186
VDS402A05558	5,558	.2188	7/32	—	35	44	0,9	82	36	6	i	4143003
VDS402A05600	5,600	.2205	—	—	35	44	0,9	82	36	6	i	4143004
VDS402A05700	5,700	.2244	—	—	35	44	1,0	82	36	6	i	4143006
VDS402A05800	5,800	.2283	—	—	35	44	1,0	82	36	6	i	4143007
VDS202A06000	6,000	.2362	—	—	35	44	1,0	82	36	6	e	4148193
VDS402A06000	6,000	.2362	—	—	35	44	1,0	82	36	6	i	4143010
VDS402A06200	6,200	.2441	—	—	43	53	1,0	91	36	8	i	4143012
VDS202A06350	6,350	.2500	1/4	E	43	53	1,1	91	36	8	e	4148197
VDS402A06350	6,350	.2500	1/4	E	43	53	1,1	91	36	8	i	4143024
VDS402A06400	6,400	.2520	—	—	43	53	1,1	91	36	8	i	4143025
VDS402A06500	6,500	.2559	—	—	43	53	1,1	91	36	8	i	4143026
VDS202A06528	6,528	.2570	—	F	43	53	1,1	91	36	8	e	4148200
VDS402A06528	6,528	.2570	—	F	43	53	1,1	91	36	8	i	4143027
VDS402A06600	6,600	.2598	—	—	43	53	1,1	91	36	8	i	4143028
VDS202A06630	6,630	.2610	—	G	43	53	1,1	91	36	8	e	4148202
VDS402A06630	6,630	.2610	—	G	43	53	1,1	91	36	8	i	4143029
VDS202A06746	6,746	.2656	17/64	—	43	53	1,1	91	36	8	e	4148204
VDS402A06746	6,746	.2656	17/64	—	43	53	1,1	91	36	8	i	4143031
VDS202A06800	6,800	.2677	—	—	43	53	1,1	91	36	8	e	4148205
VDS402A06800	6,800	.2677	—	—	43	53	1,1	91	36	8	i	4143032
VDS202A06900	6,900	.2717	—	—	43	53	1,2	91	36	8	e	4148206
VDS402A06900	6,900	.2717	—	—	43	53	1,2	91	36	8	i	4143043
VDS202A07000	7,000	.2756	—	—	43	53	1,2	91	36	8	e	4148207
VDS402A07000	7,000	.2756	—	—	43	53	1,2	91	36	8	i	4143044
VDS202A07145	7,145	.2813	9/32	—	43	53	1,2	91	36	8	e	4148209
VDS402A07145	7,145	.2813	9/32	—	43	53	1,2	91	36	8	i	4143046
VDS402A07200	7,200	.2835	—	—	43	53	1,2	91	36	8	i	4143047
VDS202A07300	7,300	.2874	—	—	43	53	1,2	91	36	8	e	4148211
VDS202A07400	7,400	.2913	—	—	43	53	1,3	91	36	8	e	4148212
VDS402A07400	7,400	.2913	—	—	43	53	1,3	91	36	8	i	4143049
VDS402A07900	7,900	.3110	—	—	43	53	1,3	91	36	8	i	4143065
VDS202A07938	7,938	.3125	5/16	—	43	53	1,3	91	36	8	e	4148219
VDS402A07938	7,938	.3125	5/16	—	43	53	1,3	91	36	8	i	4143066
VDS202A08000	8,000	.3150	—	—	43	53	1,4	91	36	8	e	4148220
VDS402A08000	8,000	.3150	—	—	43	53	1,4	91	36	8	i	4143067
VDS402A08100	8,100	.3189	—	—	49	61	1,4	103	40	10	i	4143068
VDS202A08200	8,200	.3228	—	—	49	61	1,4	103	40	10	e	4148222
VDS402A08200	8,200	.3228	—	—	49	61	1,4	103	40	10	i	4143069
VDS402A08334	8,334	.3281	21/64	—	49	61	1,4	103	40	10	i	4143071
VDS202A08433	8,433	.3320	—	Q	49	61	1,4	103	40	10	e	4148226
VDS402A08433	8,433	.3320	—	Q	49	61	1,4	103	40	10	i	4143083
VDS202A08500	8,500	.3346	—	—	49	61	1,4	103	40	10	e	4148227
VDS402A08500	8,500	.3346	—	—	49	61	1,4	103	40	10	i	4143084
VDS402A08600	8,600	.3386	—	—	49	61	1,5	103	40	10	i	4143085
VDS402A08700	8,700	.3425	—	—	49	61	1,5	103	40	10	i	4143086
VDS202A08733	8,733	.3438	11/32	—	49	61	1,5	103	40	10	e	4148230
VDS402A08733	8,733	.3438	11/32	—	49	61	1,5	103	40	10	i	4143087
VDS202A08800	8,800	.3465	—	—	49	61	1,5	103	40	10	e	4148231
VDS402A08800	8,800	.3465	—	—	49	61	1,5	103	40	10	i	4143088
VDS202A08900	8,900	.3504	—	—	49	61	1,5	103	40	10	e	4148232
VDS402A08900	8,900	.3504	—	—	49	61	1,5	103	40	10	i	4143089
VDS202A09000	9,000	.3543	—	—	49	61	1,5	103	40	10	e	4148233
VDS402A09000	9,000	.3543	—	—	49	61	1,5	103	40	10	i	4143090
VDS202A09129	9,129	.3594	23/64	—	49	61	1,6	103	40	10	e	4148235
VDS402A09129	9,129	.3594	23/64	—	49	61	1,6	103	40	10	i	4143092
VDS402A09300	9,300	.3661	—	—	49	61	1,6	103	40	10	i	4143104
VDS202A09347	9,347	.3680	—	U	49	61	1,6	103	40	10	e	4148238
VDS402A09347	9,347	.3680	—	U	49	61	1,6	103	40	10	i	4143105

VDS202A • VDS402A • 5 x D

(continued)

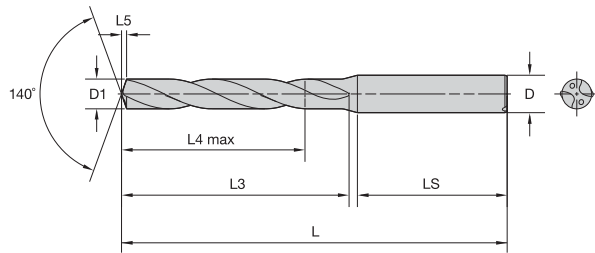

- first choice
- alternate choice

P	●
M	●
K	●
N	●
S	●
H	●

catalog number	D1 diameter			wire size	L4 max	L3	L5	L	LS	D	CF	WU25PD
	mm	in	fraction									
VDS202A09525	9,525	.3750	3/8	—	49	61	1,6	103	40	10	e	4148241
VDS402A09525	9,525	.3750	3/8	—	49	61	1,6	103	40	10	i	4143108
VDS402A09600	9,600	.3780	—	—	49	61	1,6	103	40	10	i	4143109
VDS402A09800	9,800	.3858	—	—	49	61	1,7	103	40	10	i	4143111
VDS402A10000	10,000	.3937	—	—	49	61	1,7	103	40	10	i	4142823
VDS402A10200	10,200	.4016	—	—	56	71	1,7	118	45	12	i	4142827
VDS402A10300	10,300	.4055	—	—	56	71	1,8	118	45	12	i	4142829
VDS202A10320	10,320	.4063	13/32	—	56	71	1,8	118	45	12	e	4148262
VDS402A10320	10,320	.4063	13/32	—	56	71	1,8	118	45	12	i	4142831
VDS402A10500	10,500	.4134	—	—	56	71	1,8	118	45	12	i	4142834
VDS202A10716	10,716	.4219	27/64	—	56	71	1,8	118	45	12	e	4148287
VDS402A10716	10,716	.4219	27/64	—	56	71	1,8	118	45	12	i	4142840
VDS402A11000	11,000	.4331	—	—	56	71	1,9	118	45	12	i	4142857
VDS202A11113	11,113	.4375	7/16	—	56	71	1,9	118	45	12	e	4148292
VDS402A11113	11,113	.4375	7/16	—	56	71	1,9	118	45	12	i	4142861
VDS402A11200	11,200	.4409	—	—	56	71	1,9	118	45	12	i	4142862
VDS402A11500	11,500	.4528	—	—	56	71	2,0	118	45	12	i	4142875
VDS202A11509	11,509	.4531	29/64	—	56	71	2,0	118	45	12	e	4148297
VDS202A11908	11,908	.4688	15/32	—	56	71	2,0	118	45	12	e	4148302
VDS402A11908	11,908	.4688	15/32	—	56	71	2,0	118	45	12	i	4142881
VDS202A12000	12,000	.4724	—	—	56	71	2,1	118	45	12	e	4148313
VDS402A12000	12,000	.4724	—	—	56	71	2,1	118	45	12	i	4142882
VDS202A12304	12,304	.4844	31/64	—	60	77	2,1	124	45	14	e	4148317
VDS402A12304	12,304	.4844	31/64	—	60	77	2,1	124	45	14	i	4142916
VDS202A12700	12,700	.5000	1/2	—	60	77	2,2	124	45	14	e	4148321
VDS402A12700	12,700	.5000	1/2	—	60	77	2,2	124	45	14	i	4142920
VDS402A13000	13,000	.5118	—	—	60	77	2,2	124	45	14	i	4142953
VDS202A13500	13,500	.5315	—	—	60	77	2,3	124	45	14	e	4148350
VDS402A13500	13,500	.5315	—	—	60	77	2,3	124	45	14	i	4142959
VDS202A13891	13,891	.5469	35/64	—	60	77	2,4	124	45	14	e	4148354
VDS402A14000	14,000	.5512	—	—	60	77	2,4	124	45	14	i	4142985
VDS402A14288	14,288	.5625	9/16	—	63	83	2,5	133	48	16	i	4142988
VDS402A15875	15,875	.6250	5/8	—	63	83	2,8	133	48	16	i	4143038
VDS402A16500	16,500	.6496	—	—	71	93	2,9	143	48	18	i	4143056
VDS402A16800	16,800	.6614	—	—	71	93	2,9	143	48	18	i	4143060
VDS402A17463	17,463	.6875	11/16	—	71	93	3,0	143	48	18	i	4143077
VDS202A19050	19,050	.7500	3/4	—	77	101	3,3	153	50	20	e	4148324
VDS402A19050	19,050	.7500	3/4	—	77	101	3,3	153	50	20	i	4142830
VDS402A20000	20,000	.7874	—	—	77	101	3,5	153	50	20	i	4142860

NOTE: CF = Coolant Feature:
 i = internal
 e = external
 i/e = internal and external

VDS403A • 8 x D

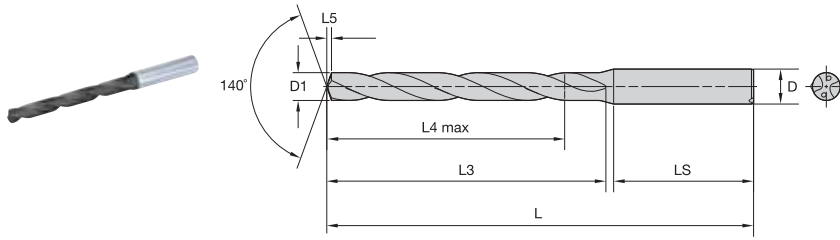

- first choice
- alternate choice

P	●
M	●
K	●
N	●
S	●
H	●

catalog number	D1 diameter				L4 max	L3	L5	L	LS	D	CF	WU25PD
	mm	in	fraction	wire size								
VDS403A01500	1,500	.0591	—	—	15	18	0,2	58	28	4	i	4143700
VDS403A01600	1,600	.0630	—	—	15	18	0,2	58	28	4	i	4143701
VDS403A01800	1,800	.0709	—	—	15	18	0,3	58	28	4	i	4143723
VDS403A02000	2,000	.0787	—	—	22	26	0,3	66	28	4	i	4143726
VDS403A02100	2,100	.0827	—	—	22	26	0,3	66	28	4	i	4143727
VDS403A02383	2,383	.0938	3/32	—	25	30	0,4	66	28	4	i	4143730
VDS403A02489	2,489	.0980	—	40	25	30	0,4	66	28	4	i	4143733
VDS403A03000	3,000	.1181	—	—	33	40	0,5	78	36	6	i	4143746
VDS403A03048	3,048	.1200	—	31	33	40	0,5	78	36	6	i	4143747
VDS403A03175	3,175	.1250	1/8	—	33	40	0,5	78	36	6	i	4143749
VDS403A03264	3,264	.1285	—	30	33	40	0,5	78	36	6	i	4143751
VDS403A03300	3,300	.1299	—	30	33	40	0,5	78	36	6	i	4143752
VDS403A03455	3,455	.1360	—	29	33	40	0,6	78	36	6	i	4143754
VDS403A03500	3,500	.1378	—	21	33	40	0,6	78	36	6	i	4143755
VDS403A03571	3,571	.1406	9/64	—	33	40	0,6	78	36	6	i	4143756
VDS403A03700	3,700	.1457	—	—	33	40	0,6	78	36	6	i	4143759
VDS403A03900	3,900	.1535	—	—	41	49	0,6	87	36	6	i	4143762
VDS403A04000	4,000	.1575	—	—	41	49	0,7	87	36	6	i	4143764
VDS403A04039	4,039	.1590	—	21	41	49	0,7	87	36	6	i	4143765
VDS403A04100	4,100	.1614	—	—	41	49	0,7	87	36	6	i	4143767
VDS403A04200	4,200	.1654	—	—	41	49	0,7	87	36	6	i	4143768
VDS403A04763	4,763	.1875	3/16	13	48	56	0,8	94	36	6	i	4143777
VDS403A04852	4,852	.1910	—	11	48	56	0,8	94	36	6	i	4143779
VDS403A05000	5,000	.1969	—	—	48	56	0,8	94	36	6	i	4143781
VDS403A05100	5,100	.2008	—	—	48	56	0,9	94	36	6	i	4143782
VDS403A05106	5,106	.2010	—	7	48	56	0,9	94	36	6	i	4143783
VDS403A05159	5,159	.2031	13/64	—	48	56	0,9	94	36	6	i	4143784
VDS403A05200	5,200	.2047	—	—	48	56	0,9	94	36	6	i	4143785
VDS403A05400	5,400	.2126	—	7	48	56	0,9	94	36	6	i	4143787
VDS403A05558	5,558	.2188	7/32	2	48	56	0,9	94	36	6	i	4143790
VDS403A05800	5,800	.2283	—	—	48	56	1,0	94	36	6	i	4143794
VDS403A06000	6,000	.2362	—	—	48	56	1,0	94	36	6	i	4143797
VDS403A06350	6,350	.2500	1/4	E	57	67	1,1	105	36	8	i	4143801
VDS403A06528	6,528	.2570	—	F	57	67	1,1	105	36	8	i	4143804
VDS403A06630	6,630	.2610	—	G	57	67	1,1	105	36	8	i	4143806
VDS403A06746	6,746	.2656	17/64	—	57	67	1,1	105	36	8	i	4143808
VDS403A06800	6,800	.2677	—	—	57	67	1,1	105	36	8	i	4143809
VDS403A07145	7,145	.2813	9/32	—	61	72	1,2	110	36	8	i	4143813
VDS403A07541	7,541	.2969	19/64	—	61	72	1,3	110	36	8	i	4143818
VDS403A07938	7,938	.3125	5/16	Q	61	72	1,3	110	36	8	i	4143823
VDS403A08000	8,000	.3150	—	—	61	72	1,4	110	36	8	i	4143824
VDS403A08100	8,100	.3189	—	—	68	80	1,4	122	40	10	i	4143825
VDS403A08200	8,200	.3228	—	—	68	80	1,4	122	40	10	i	4143826
VDS403A08500	8,500	.3346	—	—	68	80	1,4	122	40	10	i	4143831
VDS403A08700	8,700	.3425	—	—	68	80	1,5	122	40	10	i	4143833
VDS403A08733	8,733	.3438	11/32	—	68	80	1,5	122	40	10	i	4143834
VDS403A08800	8,800	.3465	—	—	68	80	1,5	122	40	10	i	4143835
VDS403A09100	9,100	.3583	—	—	68	80	1,6	122	40	10	i	4143838
VDS403A09129	9,129	.3594	23/64	—	68	80	1,6	122	40	10	i	4143839
VDS403A09525	9,525	.3750	3/8	—	68	80	1,6	122	40	10	i	4143845
VDS403A09921	9,921	.3906	25/64	—	68	80	1,7	122	40	10	i	4143850
VDS403A10200	10,200	.4016	—	—	79	94	1,7	141	45	12	i	4143473
VDS403A10300	10,300	.4055	—	—	79	94	1,8	141	45	12	i	4143474
VDS403A10320	10,320	.4063	13/32	—	79	94	1,8	141	45	12	i	4143475
VDS403A10400	10,400	.4094	—	—	79	94	1,8	141	45	12	i	4143476
VDS403A10716	10,716	.4219	27/64	—	79	94	1,8	141	45	12	i	4143480

VDS403A • 8 x D

(continued)

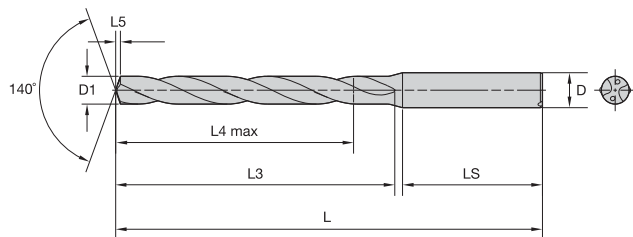

- first choice
- alternate choice

P	●
M	●
K	●
N	●
S	●
H	○

catalog number	D1 diameter			wire size	L4 max	L3	L5	L	LS	D	CF	WU25PD
	mm	in	fraction									
VDS403A10800	10,800	.4252	—	—	79	94	1,9	141	45	12	i	4143481
VDS403A10900	10,900	.4291	—	—	79	94	1,9	141	45	12	i	4143482
VDS403A11100	11,100	.4370	—	—	79	94	1,9	141	45	12	i	4143484
VDS403A11113	11,113	.4375	7/16	—	79	94	1,9	141	45	12	i	4143485
VDS403A11200	11,200	.4409	—	—	79	94	1,9	141	45	12	i	4143486
VDS403A12000	12,000	.4724	—	—	79	94	2,1	141	45	12	i	4143496
VDS403A12700	12,700	.5000	1/2	—	91	108	2,2	155	45	14	i	4143504
VDS403A13000	13,000	.5118	—	—	91	108	2,2	155	45	14	i	4143507
VDS403A13500	13,500	.5315	—	—	91	108	2,3	155	45	14	i	4143513
VDS403A14000	14,000	.5512	—	—	91	108	2,4	155	45	14	i	4143519
VDS403A14288	14,288	.5625	9/16	—	101	121	2,5	171	48	16	i	4143522
VDS403A15875	15,875	.6250	5/8	—	101	121	2,8	171	48	16	i	4143542
VDS403A16670	16,670	.6563	21/32	—	113	135	2,9	185	48	18	i	4143552
VDS403A17000	17,000	.6693	—	—	113	135	3,0	185	48	18	i	4143556

NOTE: CF = Coolant Feature:
 i = internal
 e = external
 i/e = internal and external



FOR MORE INFORMATION ON THE PRODUCTS SHOWN, PLEASE SEE PAGES F80–F95 OF THE TECHNICAL CATALOG.

THE ALL-STAR PROGRAM FEATURES ONLY THE MOST POPULAR PLATFORMS, GRADES, AND SIZES.
 FOR THE COMPLETE OFFERING, VISIT WIDIA NOVO™ OR WIDIA.COM.

ONE SOURCE, MANY APPLICATIONS

WIDIA™ APPROVED TAP/DRILL COMBINATIONS:

VariDrill™/VariTap™



Versatile:

VariDrill™ drilling tools, in combination with VariTap™ tapping tools, are designed for productivity in an array of different materials. These tools feature strong geometries that are ideal for small-batch and varied production.

TOP DRILL S™/GT Series



TDS401
TDS402
TDS403

GT00, 20, 24
Spiral Point
GT30, 32, 50
Spiral Flute
GT23, 24, 25
Forming



TDS451
TDS452
TDS453

GT20
GT30



TDS411
TDS412
TDS413

GT40
GT41



TDS421
TDS422

GT70
GT80
GT22
GT40



TDS451
TDS452
TDS453

GT60
GT90
GT62
GT92



Optimized:

TOP DRILL S™ drills, combined with GT Series Taps: This combination is designed for, but not limited to, material-specific applications with medium to large batch production.

For more than 90 years, WIDIA has defined excellence in innovation, technology, and customer service. As an industry-leading manufacturer of cutting tools, WIDIA offers a complete portfolio of precision-engineered products. With drilling, tapping and tooling systems products, you will find everything you need from one single source.

- Extensive Portfolio
- Expertise
- Customized Solutions

MODULAR DRILLS

TDMX

Pages C18–C21

Stability and reliability combined into one modular drill system.



TDM1

Pages C22–C25

With its high level of performance, wide application range, and proven point geometry, TDM1 modular drill systems combine all of the economic benefits of a modular drilling system with the machining performance and hole quality to tackle even your most challenging operations.

TUBE SHEET DRILLING SUCCESS



TDMX

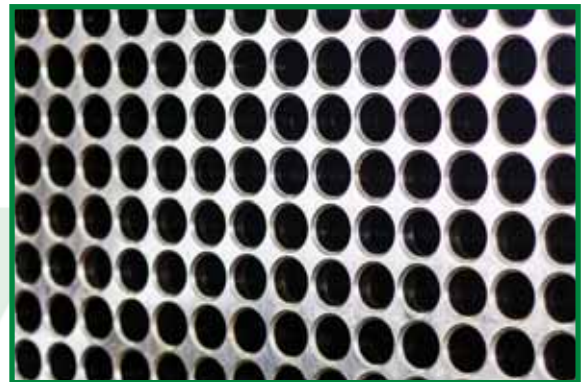

TUBE SHEET



WIDIA™
SHINING
MOMENT

**LONGER TOOL LIFE WITH LOWER SPINDLE
LOAD AND BETTER CHIP CONTROL**

Proven Solution — Tube Sheet

P Material: ST52
Condition: Pre-Drilled

	COMPETITOR	WIDIA
Insert	—	TDMX2576PKM
Diameter	25,76mm (1,014")	25,76mm (1,014")
Grade	—	WP40PD
Body	—	TDMX250SL32R5M
Length	5 x D	5 x D
Vc	100m/min (320 SFM)	100m/min (320 SFM)
RPM	1239 r/min	1239 r/min
f	0,3mm/r (.011 ipm)	0,3mm/r (.011 IPR)
Vf	371mm/min (14 ipm)	371mm/min (14 ipm)
LOC	77mm (3.03")	77mm (3.03")
Tool Life	390 holes	428 holes

TO SEE ALL PRODUCTS LINES, VISIT OUR DIGITAL RESOURCES



WIDIA NOVO™ Application
Download to your desktop or tablet:
widia.com/novo



WIDIA™ Machining Central Mobile App
Download for iOS or Android:
widia.com/en/featured/WidiaMobileApp

WIDIA 

TDMX — TOP DRILL™ Modular X

WIDIA™ TOP DRILL Modular X (TDMX) is the ultimate choice for high-demanding drilling applications when stability and reliability are required.

- Easy to apply, increased stability and performance.
- Highly engineered pocket seat design to ensure maximum stability, even in challenging applications like cross hole, inclined entry/exit, and interrupted cuts.
- Suitable for high feed rates.
- Brand new WP40PD grade for longer tool life in steel and cast iron applications.
- Easy insert nomenclature logic to identify the targeted material group.

L/D Ratio



Diameter Range

From .629" up to 1.574".

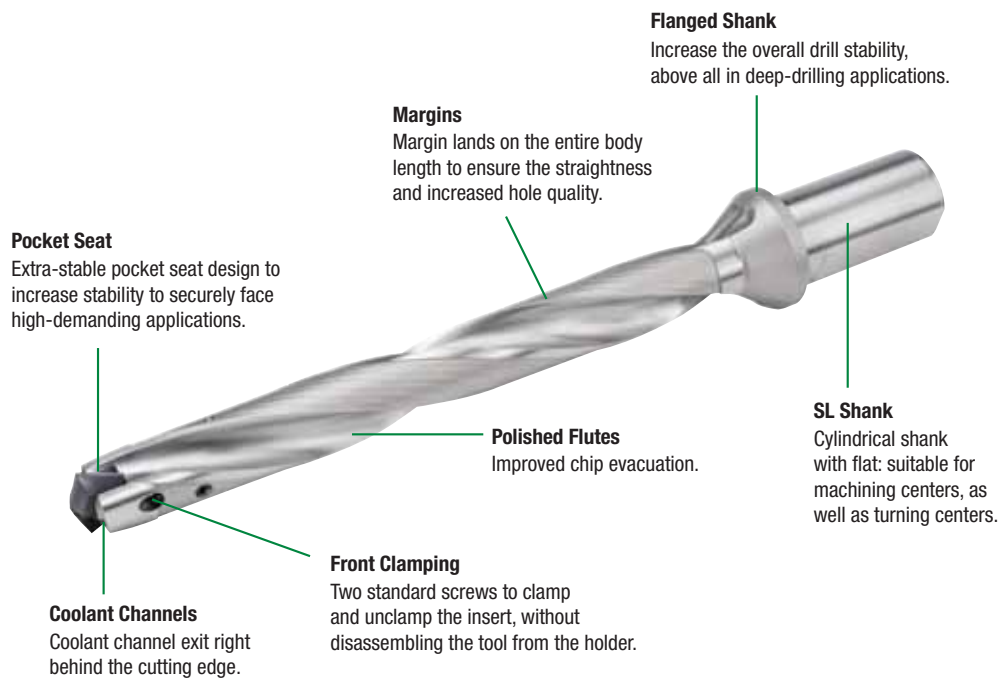
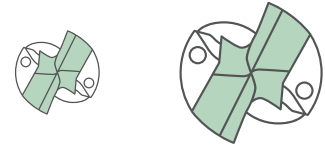

Pocket Seat

Extra-stable pocket seat design to increase stability to securely face high-demanding applications.

Coolant Channels

Coolant channel exit right behind the cutting edge.

Front Clamping

Two standard screws to clamp and unclamp the insert, without disassembling the tool from the holder.

Margins

Margin lands on the entire body length to ensure the straightness and increased hole quality.

Polished Flutes

Improved chip evacuation.

Flanged Shank

Increase the overall drill stability, above all in deep-drilling applications.

SL Shank

Cylindrical shank with flat: suitable for machining centers, as well as turning centers.

One geometry to cover two material groups in modular drilling.

PK



First choice for Steel and Cast Iron drilling.

TDMX • 3 x D • Side Lock Shank • Inch

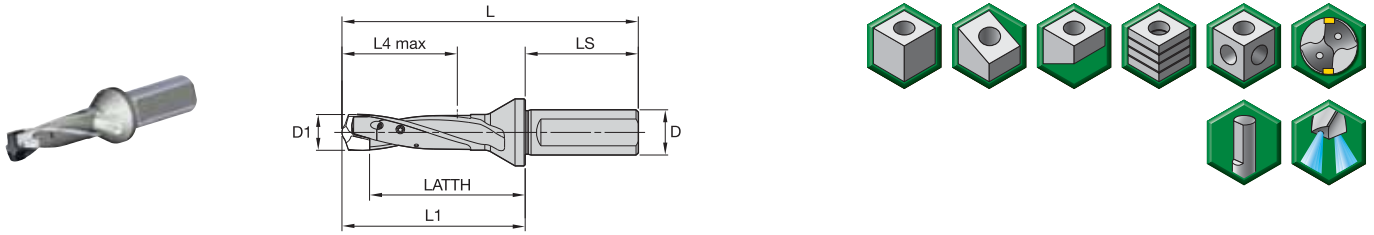

order number	catalog number	SSC	D1	D1 max
6572186	TDMX0630R3SL075	A	.6300	.6692
6572189	TDMX0749R3SL100	D	.7481	.7874
6572195	TDMX0985R3SL125	J	.9843	1.0236

NOTE: SSC = Pocket Seat Reference. To correspond with the SSC on the inserts.

TDMX • 5 x D • Side Lock Shank • Inch

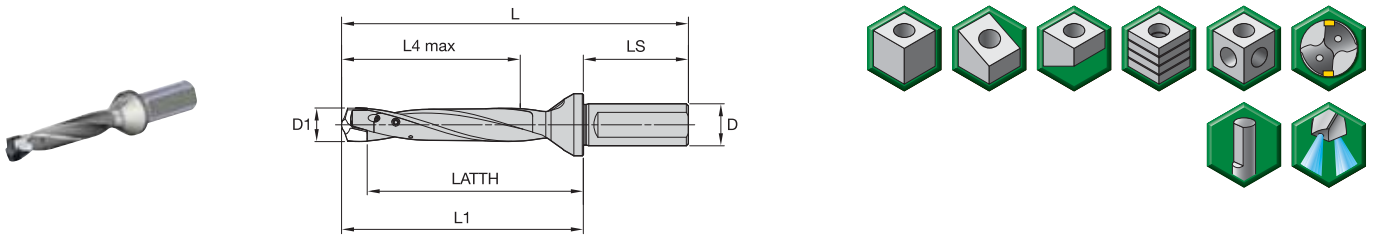

order number	catalog number	SSC	D1	D1 max
6572210	TDMX0749R5SL100	D	.7481	.7874

NOTE: SSC = Pocket Seat Reference. To correspond with the SSC on the inserts.

Dimensions

SSC	in Ø		LS	D	LATTH	SHORT ~3 x D				LONG ~5 x D			
	D1 min	D1 max				L	L1	L4 max	LATTH	L	L1	L4 max	
A	.6300	.6692	1.97	.75	2.71	5.16	3.19	2.01	4.05	6.50	4.53	3.35	
D	.7481	.7874	2.20	1.00	3.22	5.94	3.74	2.36	4.79	7.52	5.31	3.94	
J	.9843	1.0236	2.36	1.25	4.15	7.17	4.80	3.07	6.20	9.21	6.85	5.12	



FOR MORE INFORMATION ON THE PRODUCTS SHOWN, PLEASE SEE PAGES F80–F95 OF THE TECHNICAL CATALOG.

THE ALL-STAR PROGRAM FEATURES ONLY THE MOST POPULAR PLATFORMS, GRADES, AND SIZES. FOR THE COMPLETE OFFERING, VISIT WIDIA NOVO™ OR WIDIA.COM.

TDMX • Inserts • PK(M)

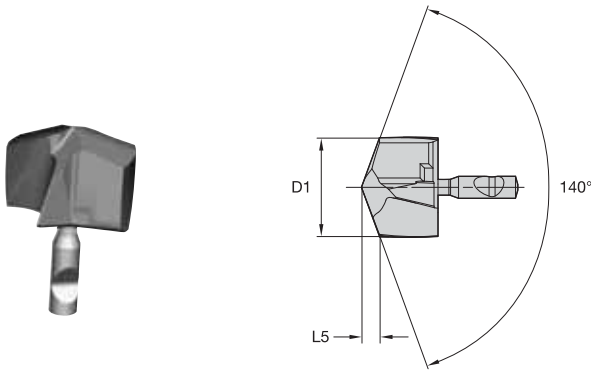

- first choice
- alternate choice

P	■	●
M	■	○
K	■	●
N	■	
S	■	
H	■	

catalog number	D1		L5		SSC	WP40PD
	mm	in	mm	in		
TDMX16667PKM	16,67	.656	3,33	.131	A	6568450
TDMX19050PKM	19,05	.750	3,78	.149	D	6568479
TDMX23813PKM	23,81	.938	4,68	.184	H	6568854
TDMX25000PKM	25,00	.984	4,91	.193	J	6568859
TDMX25400PKM	25,40	1,000	4,99	.197	J	6568860
TDMX25500PKM	25,50	1,004	5,01	.197	J	6568861

NOTE: SSC = Pocket Seat Reference. To correspond with the SSC on the toolholder.

Inch tolerance		Metric tolerance	
D1	tolerance k8	D1	tolerance k8
.3125-.3906	.000/+0.0009	8-10	0,000/+0,022
>.3906-.6250	.000/+0.0011	>10-17	0,000/+0,027
>.6692-.7090	.000/+0.0010	>17-18	0,000/+0,027
>.7090-.8228	.000/+0.0013	>18-21	0,000/+0,033



FOR MORE INFORMATION ON THE PRODUCTS SHOWN, PLEASE SEE PAGES F80-F95 OF THE TECHNICAL CATALOG.

THE ALL-STAR PROGRAM FEATURES ONLY THE MOST POPULAR PLATFORMS, GRADES, AND SIZES. FOR THE COMPLETE OFFERING, VISIT WIDIA NOVO™ OR WIDIA.COM.

ONLY TOP SELLING LINE ITEMS ARE INCLUDED IN THIS CATALOG. VISIT OUR DIGITAL RESOURCES TO VIEW THE ENTIRE PRODUCT OFFERING.

Assembling and Disassembling Instructions

▼ Assembly

1 Insert positioning

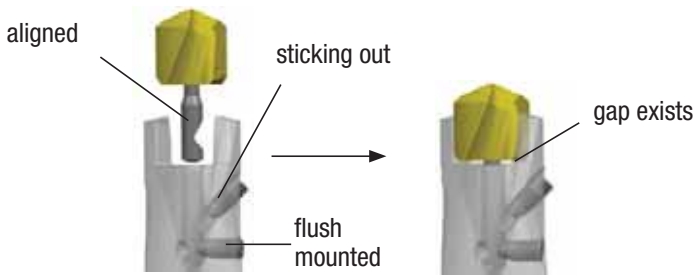

2 Insert clamping

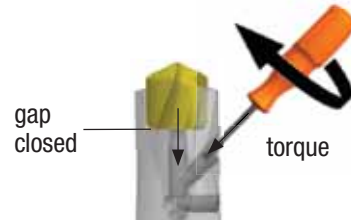

Drill diameter	Torque
ø .6300–.7874"	1.1 ft. lbs.
ø .7875–.9448"	1.5 ft. lbs.
ø .9449–1.1023"	2.2 ft. lbs.
ø 1.1024–1.5748"	3.3 ft. lbs.

▼ Disassembly

1 Clamping screw loosening

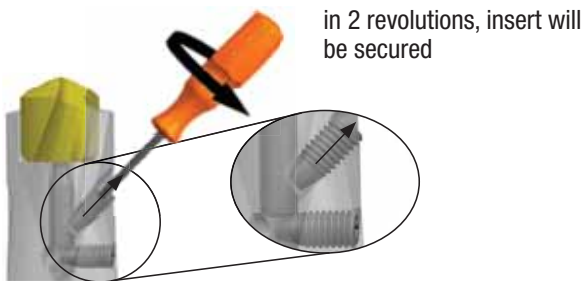

2 Insert pushing out

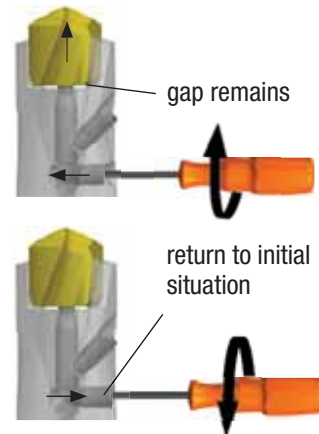

3 Further clamping screw loosening

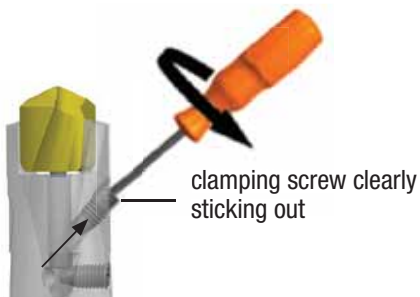

4 Insert removal



TOP DRILL M1™ Modular Drill System

With performance levels and metal removal rates comparable to that of solid carbide drills, WIDIA™ TOP DRILL M1 offers all the quality and performance you need in one versatile, economical package. The unique front clamping system enables inserts to be changed quickly, even inside the machine tool, saving setup time and manufacturing costs.

Easy Insert Change

- No screws or clamps required.
- Insert blades can be changed with a simple wrench that comes with each holder.

Disposable

- No reconditioning costs.
- Consistent performance from tip-to-tip.
- Eliminates number of tools waiting for reconditioning, thus avoiding hidden costs.

The TDM1 platform offers UP(M) drill-point design in WU25PD™ grade — a wide application range geometry, specially developed for cost-efficient drilling of steel, cast iron, and stainless steel.

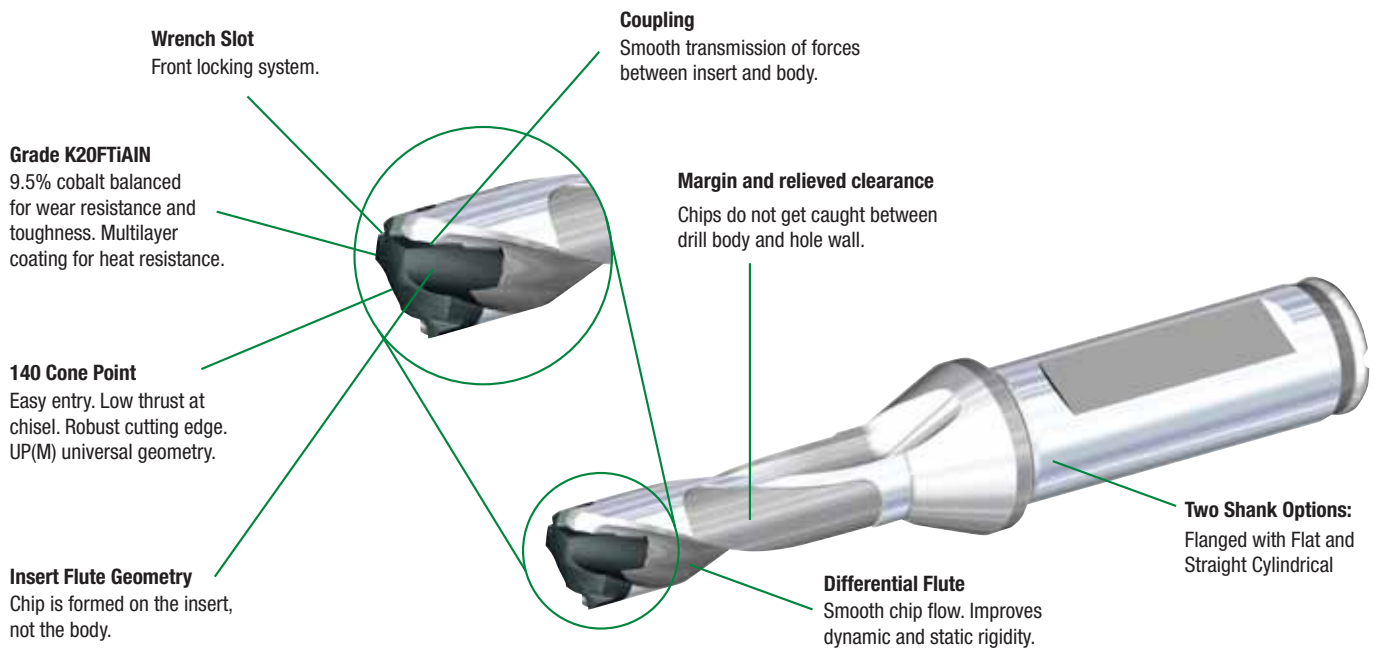

L/D Ratios

Within the standard offering.



Diameter Range

From .3159–1.0232"
(8–25.99mm).

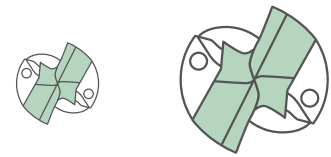

One insert style for all your work in steel, cast iron, and even stainless steels.

- Low cutting forces and excellent centering capabilities.
- Universal point style for consistent performance and excellent hole quality.



TDM1 • 3 x D • Flanged Shank • Metric

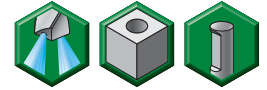
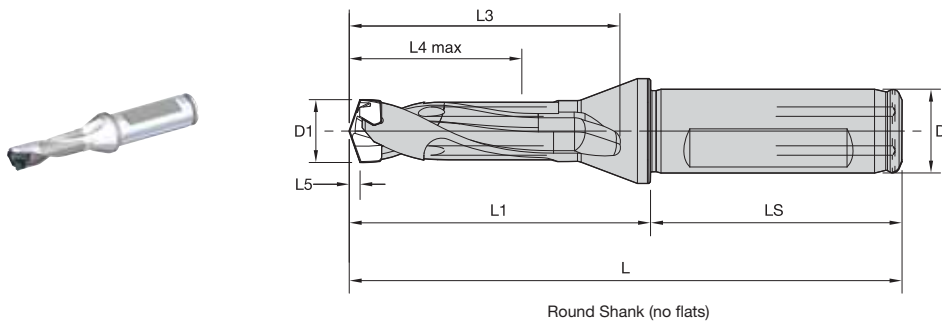

order number	catalog number	D1	D1 max	D	L	L1	L3	L4 max	L5	LS	SSC
3850930	TDM120R3SCF16M	12,00	12,49	16	106	58	52	38	2,3	48	W18

NOTE: SSC = Pocket Seat Reference. To correspond with the SSC on the inserts.

TDM1 • 3 x D • Flanged Shank • Inch

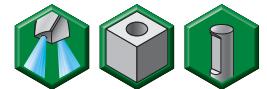
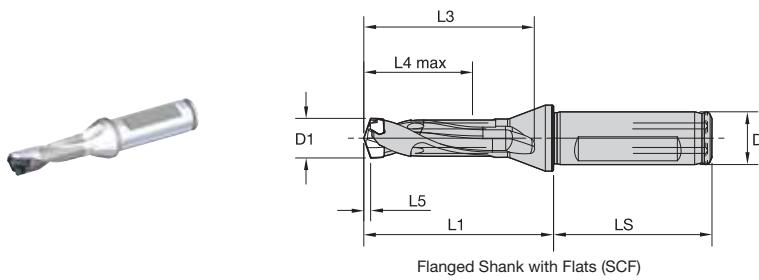

order number	catalog number	D1	D1 max	D	L1	L3	L4 max	L5	LS	SSC
4098942	TDM0413R3SCF063	.413	.4327	.6250	2.00	1.78	1.30	.076	1.89	W15
4099013	TDM0433R3SCF063	.433	.4524	.6250	2.13	1.91	1.36	.079	1.89	W16
4099016	TDM0492R3SCF063	.492	.5114	.6250	2.38	2.16	1.54	.090	1.89	W19
4099022	TDM0630R3SCF075	.630	.6689	.7500	3.00	2.78	2.01	.113	1.97	W25
4099023	TDM0669R3SCF075	.669	.7083	.7500	3.25	3.03	2.13	.121	1.97	W26
4099031	TDM0984R3SCF100	.984	1.0232	1.0000	4.50	4.28	3.07	.178	2.20	W34

NOTE: SSC = Pocket Seat Reference. To correspond with the SSC on the inserts.

TDM1 • 3 x D • Straight Shank • Inch

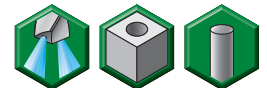
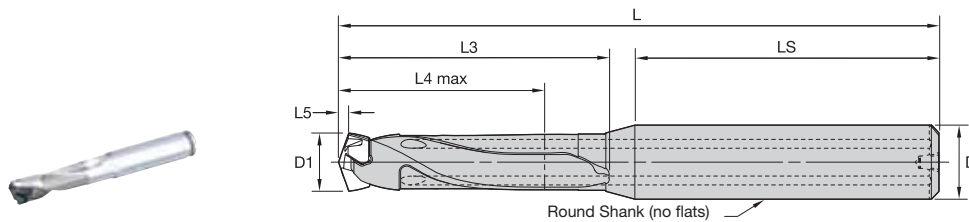

order number	catalog number	D1	D1 max	D	L	L3	L4 max	L5	LS	SSC
3851558	TDM0492R3SS050	.492	.5114	.5000	4.13	2.22	1.54	.095	1.79	W19
3851562	TDM0512R3SS056	.512	.5311	.5625	4.25	2.34	1.60	.098	1.79	W20
3851564	TDM0532R3SS056	.532	.5508	.5625	4.25	2.34	1.65	.104	1.79	W21
3851570	TDM0591R3SS063	.591	.6295	.6250	4.75	2.72	1.89	.113	1.91	W24
3851572	TDM0630R3SS069	.630	.6689	.6875	4.88	2.85	2.01	.119	1.91	W25
3851574	TDM0669R3SS069	.669	.7083	.6875	5.00	2.97	2.12	.127	1.91	W26

NOTE: SSC = Pocket Seat Reference. To correspond with the SSC on the inserts.

TDM1 • 5 x D • Flanged Shank • Inch

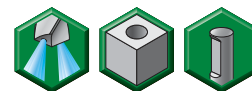
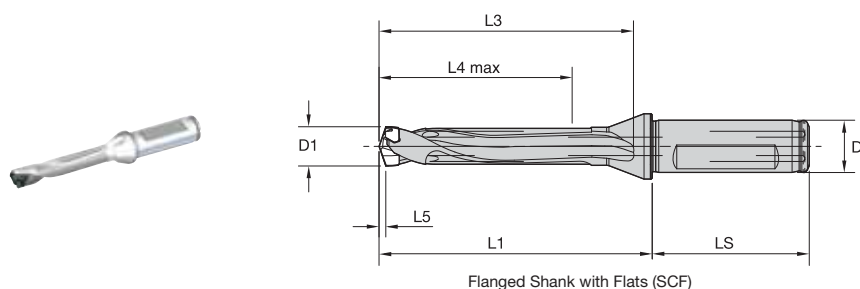

order number	catalog number	D1	D1 max	D	L1	L3	L4 max	L5	LS	SSC
4099037	TDM0413R5SCF063	.413	.4327	.6250	3.00	2.78	2.17	.076	1.89	W15
4099042	TDM0512R5SCF063	.512	.5311	.6250	3.63	3.41	2.66	.093	1.89	W20
4099046	TDM0591R5SCF075	.591	.6295	.7500	4.25	4.03	3.15	.107	1.97	W24
4099048	TDM0669R5SCF075	.669	.7083	.7500	4.75	4.53	3.54	.121	1.97	W26
4099051	TDM0787R5SCF100	.787	.8264	1.0000	5.38	5.16	4.13	.143	2.20	W29
4099056	TDM0984R5SCF100	.984	1.0232	1.0000	6.75	6.53	5.12	.178	2.20	W34

NOTE: SSC = Pocket Seat Reference. To correspond with the SSC on the inserts.

TDM1 • 5 x D • Straight Shank • Inch

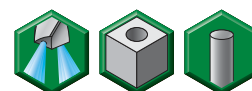
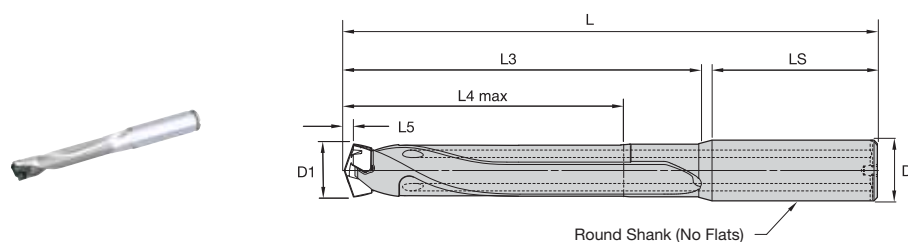

order number	catalog number	D1	D1 max	D	L	L3	L4 max	L5	LS	SSC
3851481	TDM0335R5SS038	.335	.3539	.3750	4.00	2.29	1.77	.065	1.59	W11
3851543	TDM0354R5SS038	.354	.3736	.3750	4.13	2.42	1.87	.069	1.59	W12
3851549	TDM0394R5SS044	.394	.4130	.4375	4.63	2.84	2.07	.076	1.67	W14
3851551	TDM0413R5SS044	.413	.4327	.4375	4.75	2.96	2.16	.081	1.67	W15
3851553	TDM0433R5SS044	.433	.4524	.4375	4.88	3.09	2.26	.084	1.67	W16
3851555	TDM0453R5SS050	.453	.4720	.5000	5.00	3.09	2.36	.086	1.79	W17
3851565	TDM0532R5SS056	.532	.5508	.5625	5.50	3.59	2.75	.104	1.79	W21
3851567	TDM0551R5SS056	.551	.5705	.5625	5.75	3.84	2.85	.107	1.79	W22

NOTE: SSC = Pocket Seat Reference. To correspond with the SSC on the inserts.

TDM1 • 8 x D • Flanged Shank • Inch

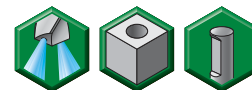
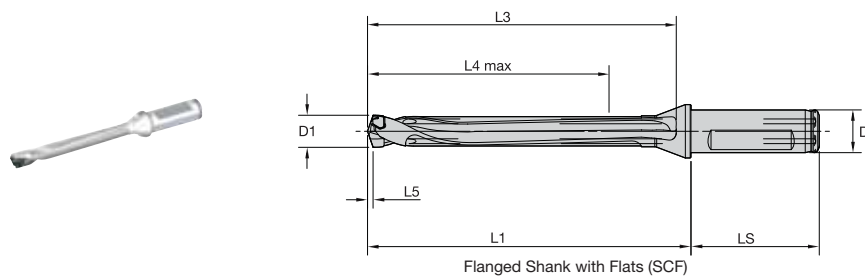

order number	catalog number	D1	D1 max	D	L1	L3	L4 max	L5	LS	SSC
4099062	TDM0413R8SCF063	.413	.4327	.6250	4.25	4.03	3.46	.076	1.89	W15
4099067	TDM0512R8SCF063	.512	.5311	.6250	5.13	4.91	4.25	.093	1.89	W20
4099069	TDM0551R8SCF063	.551	.5705	.6250	5.63	5.41	4.57	.101	1.89	W22
4099073	TDM0669R8SCF075	.669	.7083	.7500	6.88	6.66	5.67	.121	1.97	W26

NOTE: SSC = Pocket Seat Reference. To correspond with the SSC on the inserts.

TDM1 • Inserts • UP(M)

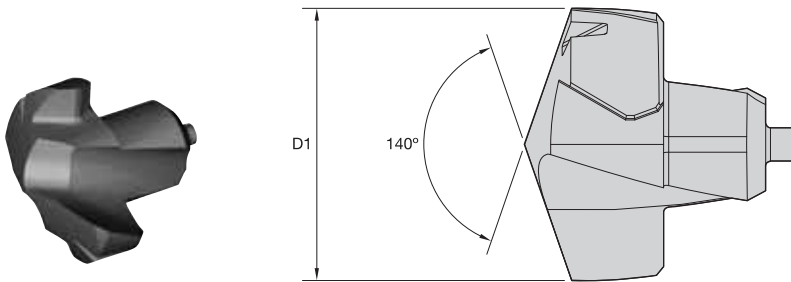

- first choice
- alternate choice

P		●
M		○
K		●
N		○
S		○
H		○

catalog number	mm	in	SSC	WU25PD
TDM0794UPM	7,94	.313	W10	3850959
TDM0800UPM	8,00	.315	W10	3848984
TDM0870UPM	8,70	.343	W11	3848990
TDM0880UPM	8,80	.347	W11	3848991
TDM0935UPM	9,35	.368	W12	3850969
TDM0950UPM	9,50	.374	W13	3849048
TDM0953UPM	9,53	.375	W13	3850970
TDM0960UPM	9,60	.378	W13	3849049
TDM0980UPM	9,80	.386	W13	3850974
TDM1030UPM	10,30	.406	W14	3849054
TDM1032UPM	10,32	.406	W14	3850979
TDM1070UPM	10,70	.421	W15	3849058
TDM1080UPM	10,80	.425	W15	3849059
TDM1090UPM	10,90	.429	W15	3849060
TDM1100UPM	11,00	.433	W16	3849061
TDM1110UPM	11,10	.437	W16	3849062
TDM1111UPM	11,11	.438	W16	3850982
TDM1150UPM	11,50	.453	W17	3849066
TDM1210UPM	12,10	.476	W18	3849072
TDM1220UPM	12,20	.480	W18	3849073
TDM1230UPM	12,30	.484	W18	3850986
TDM1250UPM	12,50	.492	W19	3849075
TDM1270UPM	12,70	.500	W19	3850988
TDM1280UPM	12,80	.504	W19	3849077
TDM1310UPM	13,10	.516	W20	3850990
TDM1349UPM	13,49	.531	W20	3850991
TDM1350UPM	13,50	.532	W21	3849082
TDM1360UPM	13,60	.535	W21	3849083
TDM1400UPM	14,00	.551	W22	3849086
TDM1429UPM	14,29	.563	W22	3850994
TDM1430UPM	14,30	.563	W22	3849089
TDM1500UPM	15,00	.591	W24	3849096
TDM1508UPM	15,08	.594	W24	3850997
TDM1530UPM	15,30	.602	W24	3849099
TDM1550UPM	15,50	.610	W24	3849101
TDM1588UPM	15,88	.625	W24	3850999
TDM1600UPM	16,00	.630	W25	3849105
TDM1618UPM	16,18	.637	W25	4010625
TDM1667UPM	16,67	.656	W25	3851003
TDM1670UPM	16,70	.658	W25	3849112
TDM1746UPM	17,46	.688	W26	3851006
TDM1750UPM	17,50	.689	W26	3849194
TDM1800UPM	18,00	.709	W27	3849199
TDM1826UPM	18,26	.719	W27	3851008
TDM1850UPM	18,50	.728	W27	3849204
TDM1905UPM	19,05	.750	W28	3851010
TDM1910UPM	19,10	.752	W28	3849210
TDM1945UPM	19,45	.766	W28	3851015
TDM1984UPM	19,84	.781	W28	3851016
TDM2000UPM	20,00	.788	W29	3849219
TDM2060UPM	20,60	.811	W29	3849225
TDM2064UPM	20,64	.813	W29	3851018
TDM2100UPM	21,00	.827	W30	4003225
TDM2223UPM	22,23	.875	W31	4003204
TDM2300UPM	23,00	.906	W32	4003228
TDM2381UPM	23,81	.938	W32	4003206
TDM2461UPM	24,61	.969	W33	4003207
TDM2540UPM	25,40	1.000	W34	4003208
TDM2550UPM	25,50	1.004	W34	4002444
TDM2599UPM	25,99	1.023	W34	3992013

NOTE: SSC = Pocket Seat Reference. To correspond with the SSC on the toolholder.

INDEXABLE DRILLS

Top Cut 4™

Pages C28–C37

The next generation of indexable drilling.



TRANSPORTATION



▲
Flange



▲
Transmission



▲
Connecting Rod



WIDIA™ manufactures tools to meet application needs in steel, cast iron, and aluminum automotive components.

TO SEE ALL PRODUCTS LINES, VISIT OUR DIGITAL RESOURCES



WIDIA NOVO™ Application
Download to your desktop or tablet:
widia.com/novo



WIDIA™ Machining Central Mobile App
Download for iOS or Android:
widia.com/en/featured/WidiaMobileApp

Top Cut 4™

WIDIA™ Top Cut 4 (TC4) portfolio is a broad offering for customers looking for a versatile indexable drilling platform.

- Easy to apply, highly versatile.
- No risk of mixing up inner and outer insert due to clear visual differences.
- Easy-to-change inserts, laser marked with geometries and grades.
- Easy-to-use nomenclature guide enabling the tool body and the related insert selection to avoid order failures.
- Breadth of application capabilities include through and cross holes, inclined entry and exit opportunity, 45° corner, half cylindrical, concave, or chain drilling.
- Four grades to achieve higher tool life at accelerated speeds:
 - WU25CH grade for highest metal removal rate in general applications.
 - WU40PH grade for high toughness demands.
 - WPK10CH grade for high-speed applications.
 - WN10PH grade specific for aluminum and other non-ferrous materials.

L/D Ratios



Standard diameter range covering

.473–2.677"

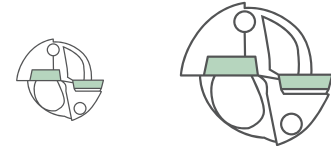

Flanged Shank

Increase the overall drill stability, above all in deep-drilling applications.

Coolant Channels

Coolant channel exit right behind the cutting edge.

Differentiated Inserts Shape

To avoid grade mixing between central and periphery inserts.

Optimized Chip Flute

Large and optimized flutes to contain chips during machining.

SL Shank Style

Cylindrical Shank with flat: suitable for machining centers, as well as turning centers.

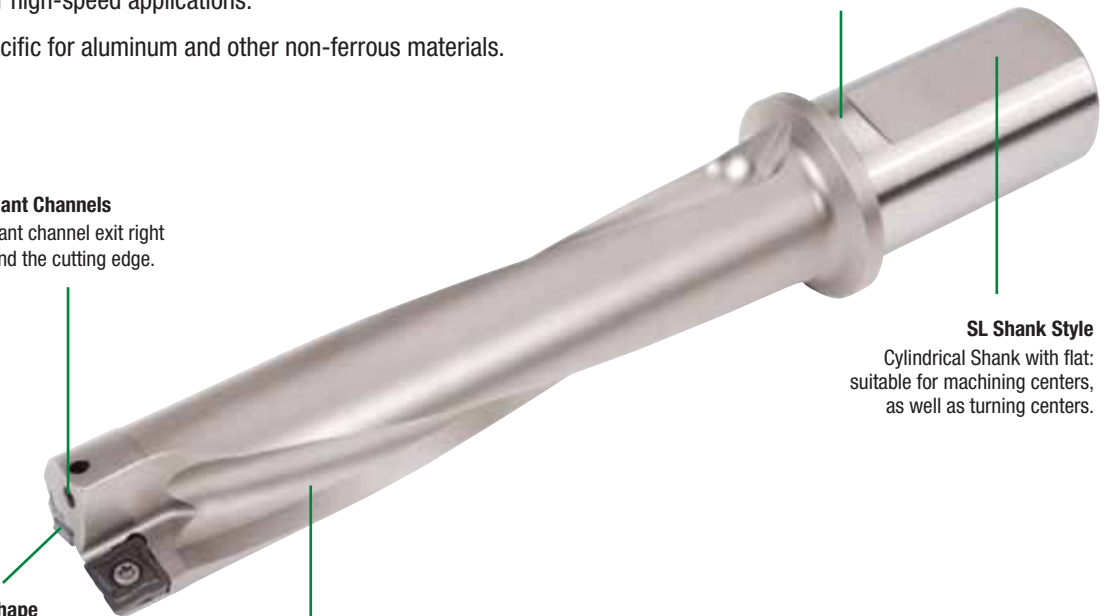

Top Cut 4 Inserts Expansion — Long Chip Materials — Non-Ferrous Materials.

- Four real cutting edges on each insert for entire platform.
- Eight insert sizes to cover complete diameter range.

-V34



P K

First choice for machining Steel, Cast Iron, and short chipping materials. Suitable for severe cutting conditions.

-V36



P M K

First choice for Stainless Steel. Suitable for deep drilling and where low power consumption is required.

-V36 WN10PH



N

First choice for Non-Ferrous materials.

-V38



P M S

Ideal for long chipping materials.

TC4 • 2 x D • SLR Shanks • Metric

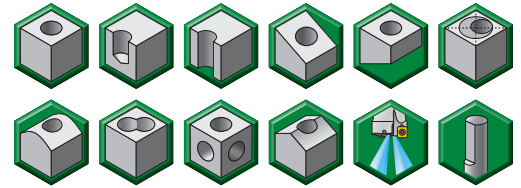
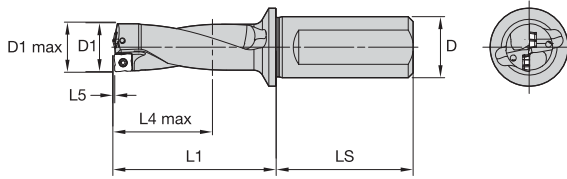

order number	catalog number	D1	D1 max	D	L1	L4 max	L5	LS	SSC	periphery insert	center insert
5537939	TCF320R2SLR32ME	32,00	33,00	32	99,2	65,2	1,15	60,00	E	TCF100408EP	TCF120405EC

NOTE: SSC = Pocket Seat Reference. To correspond with the SSC on the inserts.

WARNING

During through-hole operations, a slug or disc is produced as the tool breaks through the workpiece. When the drill is stationary and the workpiece is rotating, this slug may be hurled from the chuck by centrifugal force. Provide adequate shielding to protect bystanders.

TC4 • 2 x D • SLR Shanks • Inch

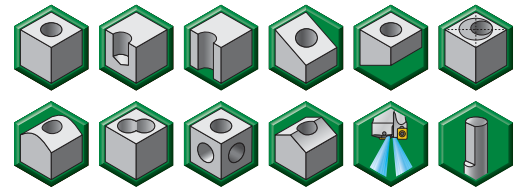
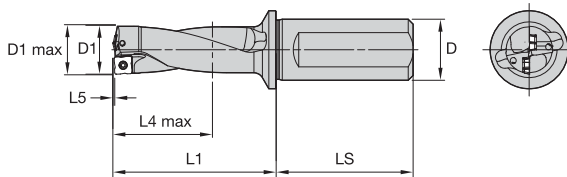

order number	catalog number	D1	D1 max	D	L1	L4 max	L5	LS	SSC	periphery insert	center insert
5578228	TCF0625R2SLR075B	.625	.645	.75	2.118	1.273	.023	1.969	B	TCF050204BP	TCF060203BC
5578379	TCF0750R2SLR100C	.750	.770	1.00	2.510	1.527	.027	2.205	C	TCF070306CP	TCF070304CC
5578402	TCF0844R2SLR100C	.844	.864	1.00	2.804	1.718	.030	2.205	C	TCF070306CP	TCF070304CC
5537845	TCF0969R2SLR100D	.969	1.008	1.00	3.100	1.973	.035	2.205	D	TCF080308DP	TCF090305DC
5537968	TCF1250R2SLR125E	1.250	1.289	1.25	3.867	2.545	.045	2.362	E	TCF100408EP	TCF120405EC
5578652	TCF1500R2SLR150F	1.500	1.539	1.50	4.641	3.055	.055	2.756	F	TCF120412FP	TCF150406FC
5578658	TCF1750R2SLR150F	1.750	1.789	1.50	5.373	3.562	.062	2.756	F	TCF120412FP	TCF150406FC
5578768	TCF2000R2SLR150G	2.000	2.039	1.50	5.907	4.071	.071	2.756	G	TCF150512GP	TCF180508GC

NOTE: SSC = Pocket Seat Reference. To correspond with the SSC on the inserts.

WARNING

During through-hole operations, a slug or disc is produced as the tool breaks through the workpiece. When the drill is stationary and the workpiece is rotating, this slug may be hurled from the chuck by centrifugal force. Provide adequate shielding to protect bystanders.



FOR MORE INFORMATION ON THE PRODUCTS SHOWN, PLEASE SEE PAGES F80–F95 OF THE TECHNICAL CATALOG.

THE ALL-STAR PROGRAM FEATURES ONLY THE MOST POPULAR PLATFORMS, GRADES, AND SIZES. FOR THE COMPLETE OFFERING, VISIT WIDIA NOVO™ OR WIDIA.COM.

TC4 • 3 x D • SLR Shanks • Inch

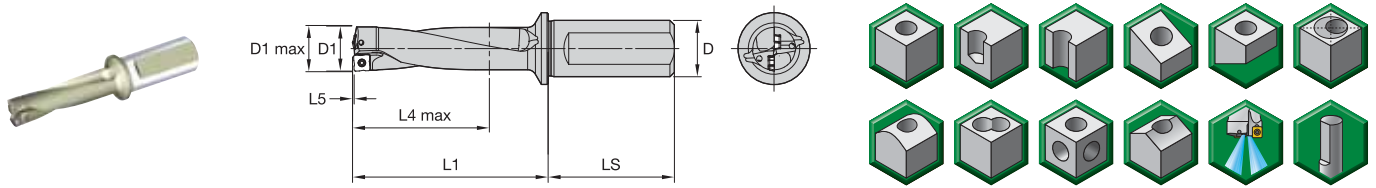

order number	catalog number	D1	D1 max	D	L1	L4 max	L5	LS	SSC	periphery insert	center insert
5578307	TCF0656R3SLR075B	.656	.676	.75	2.871	1.992	.024	1.969	B	TCF050204BP	TCF060203BC
5578308	TCF0688R3SLR075B	.688	.708	.75	3.003	2.089	.025	1.969	B	TCF050204BP	TCF060203BC
5578406	TCF0750R3SLR100C	.750	.770	1.00	3.260	2.277	.027	2.205	C	TCF070306CP	TCF070304CC
5578407	TCF0781R3SLR100C	.781	.801	1.00	3.388	2.371	.028	2.205	C	TCF070306CP	TCF070304CC
5578408	TCF0813R3SLR100C	.813	.833	1.00	3.520	2.468	.029	2.205	C	TCF070306CP	TCF070304CC
5578410	TCF0875R3SLR100C	.875	.895	1.00	3.776	2.656	.031	2.205	C	TCF070306CP	TCF070304CC
5578412	TCF0938R3SLR100C	.938	.958	1.00	4.035	2.846	.032	2.205	C	TCF070306CP	TCF070304CC
5537913	TCF0969R3SLR100D	.969	1.008	1.00	4.069	2.942	.035	2.205	D	TCF080308DP	TCF090305DC
5537915	TCF1000R3SLR100D	1.000	1.039	1.00	4.194	3.036	.036	2.205	D	TCF080308DP	TCF090305DC
5537916	TCF1031R3SLR125D	1.031	1.070	1.25	4.358	3.130	.037	2.362	D	TCF080308DP	TCF090305DC
5537917	TCF1063R3SLR125D	1.063	1.102	1.25	4.487	3.227	.038	2.362	D	TCF080308DP	TCF090305DC
5538067	TCF1250R3SLR125E	1.250	1.289	1.25	5.117	3.795	.045	2.362	E	TCF100408EP	TCF120405EC
5538080	TCF1375R3SLR125E	1.375	1.414	1.25	5.608	4.174	.049	2.362	E	TCF100408EP	TCF120405EC
5578670	TCF1500R3SLR150F	1.500	1.539	1.50	6.141	4.555	.055	2.756	F	TCF120412FP	TCF150406FC
5578676	TCF1750R3SLR150F	1.750	1.789	1.50	7.123	5.312	.062	2.756	F	TCF120412FP	TCF150406FC
5578794	TCF2000R3SLR150G	2.000	2.039	1.50	7.836	7.836	.071	2.756	G	TCF150512GP	TCF180508GC

NOTE: SSC = Pocket Seat Reference. To correspond with the SSC on the inserts.

WARNING

During through-hole operations, a slug or disc is produced as the tool breaks through the workpiece. When the drill is stationary and the workpiece is rotating, this slug may be hurled from the chuck by centrifugal force. Provide adequate shielding to protect bystanders.



FOR MORE INFORMATION ON THE PRODUCTS SHOWN, PLEASE SEE PAGES F80–F95 OF THE TECHNICAL CATALOG.

THE ALL-STAR PROGRAM FEATURES ONLY THE MOST POPULAR PLATFORMS, GRADES, AND SIZES. FOR THE COMPLETE OFFERING, VISIT WIDIA NOVO™ OR WIDIA.COM.

TC4 • 4 x D • SLR Shanks • Inch

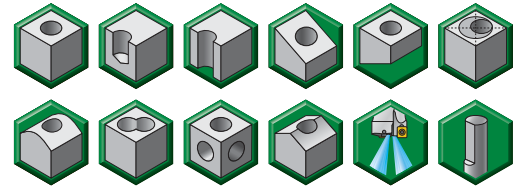
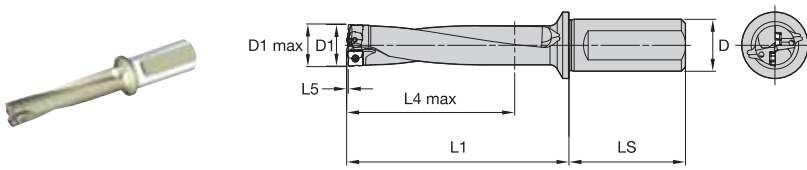

order number	catalog number	D1	D1 max	D	L1	L4 max	L5	LS	SSC	periphery insert	center insert
5578314	TCF0625R4SLR075B	.625	.645	.75	3.368	2.523	.023	1.969	B	TCF050204BP	TCF060203BC
5578417	TCF0875R4SLR100C	.875	.895	1.00	4.651	3.531	.031	2.205	C	TCF070306CP	TCF070304CC
5537923	TCF1000R4SLR100D	1.000	1.039	1.00	5.194	4.036	.036	2.205	D	TCF080308DP	TCF090305DC
5538086	TCF1250R4SLR125E	1.250	1.289	1.25	6.367	5.045	.045	2.362	E	TCF100408EP	TCF120405EC
5578678	TCF1500R4SLR150F	1.500	1.539	1.50	7.641	6.054	.055	2.756	F	TCF120412FP	TCF150406FC
5578681	TCF1625R4SLR150F	1.625	1.664	1.50	8.257	6.558	.058	2.756	F	TCF120412FP	TCF150406FC

NOTE: SSC = Pocket Seat Reference. To correspond with the SSC on the inserts.

WARNING

During through-hole operations, a slug or disc is produced as the tool breaks through the workpiece. When the drill is stationary and the workpiece is rotating, this slug may be hurled from the chuck by centrifugal force. Provide adequate shielding to protect bystanders.

TC4 • 5 x D • SLR Shanks • Inch

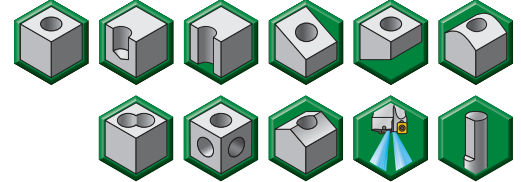
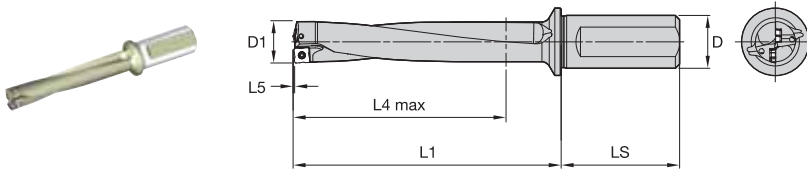

order number	catalog number	D1	D	L1	L4 max	L5	LS	SSC	periphery insert	center insert
5537889	TCF0500R5SLR075A	.500	.75	3.276	2.518	.018	1.969	A	TCF040204AP	TCF040203AC
5537890	TCF0531R5SLR075A	.531	.75	3.469	2.674	.019	1.969	A	TCF040204AP	TCF040203AC
5578424	TCF0875R5SLR100C	.875	1.00	5.526	4.406	.031	2.205	C	TCF070306CP	TCF070304CC
5537931	TCF1000R5SLR100D	1.000	1.00	6.194	5.036	.036	2.205	D	TCF080308DP	TCF090305DC
5538095	TCF1250R5SLR125E	1.250	1.25	7.617	6.295	.045	2.362	E	TCF100408EP	TCF120405EC
5538509	TCF2250R5SLR150H	2.250	1.50	13.142	11.331	.081	2.756	H	TCF180614HP	TCF210608HC
5538511	TCF2500R5SLR150H	2.500	1.50	14.574	12.588	.088	2.756	H	TCF180614HP	TCF210608HC

NOTE: SSC = Pocket Seat Reference. To correspond with the SSC on the inserts.

WARNING

During through-hole operations, a slug or disc is produced as the tool breaks through the workpiece. When the drill is stationary and the workpiece is rotating, this slug may be hurled from the chuck by centrifugal force. Provide adequate shielding to protect bystanders.

TC4 • Center Inserts • Aluminum • V36

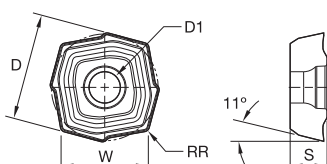
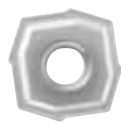

- first choice
- alternate choice

P	■	●
M	■	●
K	■	●
N	■	●
S	■	●
H	■	●

catalog number	D		D1		W		S		RR		SSC	WNT10PH
	mm	in	mm	in	mm	in	mm	in	mm	in		
TCF090305DCV36	9,55	.376	2,80	.110	7,80	.307	3,00	.118	0,500	.019	D	6372045
TCF120405ECV36	12,00	.473	3,40	.134	9,80	.386	3,60	.142	0,500	.019	E	6372047

NOTE: SSC = Pocket Seat Reference. To correspond with the SSC on the toolholder.

TC4 • Center Inserts • Long Chip Materials • V38

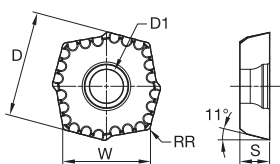

- first choice
- alternate choice

P	■	●
M	■	●
K	■	●
N	■	●
S	■	●
H	■	●

catalog number	D		D1		W		S		RR		SSC	WU40PH
	mm	in	mm	in	mm	in	mm	in	mm	in		
TCF070304CCV38	7,59	.299	2,60	.102	6,20	.244	2,80	.110	0,400	.015	C	6429460
TCF090305DCV38	9,55	.376	2,80	.110	7,80	.307	3,00	.118	0,500	.019	D	6429461
TCF120405ECV38	12,00	.473	3,40	.134	9,80	.386	3,60	.142	0,500	.019	E	6429462
TCF150406FCV38	14,94	.588	4,80	.189	12,20	.480	4,20	.165	0,600	.023	F	6429463
TCF180508GCV38	17,88	.704	6,00	.236	14,60	.575	5,40	.213	0,800	.031	G	6324383
TCF210608HCV38	21,68	.853	7,50	.295	17,70	.697	6,50	.256	0,800	.031	H	6429464

NOTE: SSC = Pocket Seat Reference. To correspond with the SSC on the toolholder.

Refer to the WIDIA™ 2017 Master Catalog (A-15-04580EN_in) or the NOVO™ application for the complete geometry offering.

TC4 • Center Inserts • V34

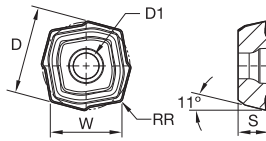
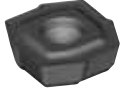

- first choice
- alternate choice

P	●	○
M	●	○
K	●	○
N	○	○
S	○	○
H	○	○

catalog number	D		D1		W		S		RR		SSC	WU25CH	WU40PH
	mm	in	mm	in	mm	in	mm	in	mm	in			
TCF040203ACV34	4,47	.176	2,10	.083	3,65	.144	2,00	.079	0,300	.011	A	5541817	5541818
TCF060203BCV34	6,00	.236	2,40	.094	4,90	.193	2,40	.095	0,300	.011	B	5542604	5542604
TCF070304CCV34	7,59	.299	2,60	.102	6,20	.244	2,80	.110	0,400	.015	C	5542642	5542643
TCF090305DCV34	9,55	.376	2,80	.110	7,80	.307	3,00	.118	0,500	.019	D	5538554	5538555
TCF120405ECV34	12,00	.473	3,40	.134	9,80	.386	3,60	.142	0,500	.019	E	5538603	5538604
TCF150406FCV34	14,94	.588	4,80	.189	12,20	.480	4,20	.165	0,600	.023	F	5542623	5542624
TCF180508GCV34	17,88	.704	6,00	.236	14,60	.575	5,40	.213	0,800	.031	G	5542476	5542476
TCF210608HCV34	21,68	.853	7,50	.295	17,70	.697	6,50	.256	0,800	.031	H	5542003	5542003

NOTE: For application-specific insert selection, please refer to the application data on pages F92–F95.
SSC = Pocket Seat Reference. To correspond with the SSC on the toolholder.



FOR MORE INFORMATION ON THE PRODUCTS SHOWN, PLEASE SEE PAGES F80–F95 OF THE TECHNICAL CATALOG.

THE ALL-STAR PROGRAM FEATURES ONLY THE MOST POPULAR PLATFORMS, GRADES, AND SIZES.
FOR THE COMPLETE OFFERING, VISIT WIDIA NOVO™ OR WIDIA.COM.

TC4 • Center Inserts • V36

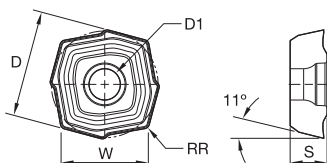
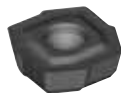

● first choice
○ alternate choice

P	●	○	●
M	●	○	●
K	●	○	●
N	●	○	●
S	●	○	●
H	●	○	●

catalog number	D		D1		W		S		RR		SSC	WU25CH	WU40PH
	mm	in	mm	in	mm	in	mm	in	mm	in			
TCF040203ACV36	4,47	.176	2,10	.083	3,65	.144	2,00	.079	0,300	.011	A	5541840	5541840
TCF060203BCV36	6,00	.236	2,40	.094	4,90	.193	2,40	.095	0,300	.011	B	5542606	5542607
TCF070304CCV36	7,59	.299	2,60	.102	6,20	.244	2,80	.110	0,400	.015	C	5542644	5542645
TCF090305DCV36	9,55	.376	2,80	.110	7,80	.307	3,00	.118	0,500	.019	D	5538556	5538557
TCF120405ECV36	12,00	.473	3,40	.134	9,80	.386	3,60	.142	0,500	.019	E	5538607	5538607
TCF150406FCV36	14,94	.588	4,80	.189	12,20	.480	4,20	.165	0,600	.023	F	5542626	5542626
TCF180508GCV36	17,88	.704	6,00	.236	14,60	.575	5,40	.213	0,800	.031	G	5542478	5542478
TCF210608HCV36	21,68	.853	7,50	.295	17,70	.697	6,50	.256	0,800	.031	H	5542005	5542005

NOTE: For application-specific insert selection, please refer to the application data on pages F92–F95 in the Technical Data Catalog.
SSC = Pocket Seat Reference. To correspond with the SSC on the toolholder.



FOR MORE INFORMATION ON THE PRODUCTS SHOWN, PLEASE SEE PAGES F80–F95 OF THE TECHNICAL CATALOG.

THE ALL-STAR PROGRAM FEATURES ONLY THE MOST POPULAR PLATFORMS, GRADES, AND SIZES.
FOR THE COMPLETE OFFERING, VISIT WIDIA NOVO™ OR WIDIA.COM.

TC4 • Periphery Inserts • Aluminum • V36

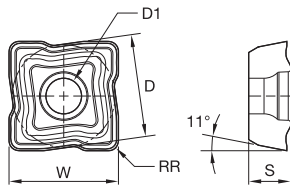

- first choice
- alternate choice

P	■	○
M	■	○
K	■	○
N	■	●
S	■	○
H	■	○

catalog number	D		D1		W		S		RR		SSC	WNT10PH 6372044
	mm	in	mm	in	mm	in	mm	in	mm	in		
TCF080308DPV36	8,08	.318	2,80	.110	8,60	.339	3,00	.118	0,800	.031	D	

NOTE: SSC = Pocket Seat Reference. To correspond with the SSC on the toolholder.

TC4 • Periphery Inserts • Long Chip Materials • V38

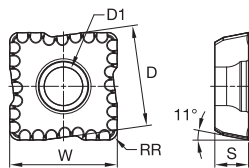

- first choice
- alternate choice

P	■	○	●
M	■	○	●
K	■	○	●
N	■	○	●
S	■	○	●
H	■	○	●

catalog number	D		D1		W		S		RR		SSC	WU25CH WU40PH
	mm	in	mm	in	mm	in	mm	in	mm	in		
TCF070306CPV38	6,67	.263	2,60	.102	7,10	.280	2,80	.110	0,600	.023	C	6429466 6429428
TCF080308DPV38	8,08	.318	2,80	.110	8,60	.339	3,00	.118	0,800	.031	D	6429430
TCF100408EPV38	9,96	.392	3,40	.134	10,60	.417	3,60	.142	0,800	.031	E	6429452
TCF120412FPV38	12,59	.496	4,80	.189	13,40	.528	4,20	.165	1,200	.046	F	6429454
TCF150512GPV38	15,13	.596	6,00	.236	16,10	.634	5,40	.213	1,200	.046	G	6324381
TCF180614HPV38	18,04	.710	7,50	.295	19,20	.756	6,50	.256	1,400	.054	H	6429457

NOTE: SSC = Pocket Seat Reference. To correspond with the SSC on the toolholder.
Refer to the WIDIA™ 2017 Master Catalog (A-15-04580EN_in) or the NOVO™ application for the complete geometry offering.

TC4 • Periphery Inserts • V34

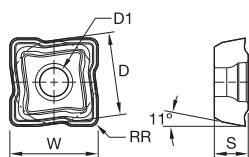
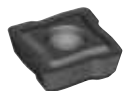

● first choice
○ alternate choice

P	●	○	○	○
M	●	○	○	○
K	●	○	○	○
N	●	○	○	○
S	●	○	○	○
H	●	○	○	○

catalog number	D		D1		W		S		RR		SSC	WPK10CH	WU25CH	WU40PH
	mm	in	mm	in	mm	in	mm	in	mm	in				
TCF040204APV34	4,14	.163	2,10	.083	4,40	.173	2,00	.079	0,400	.015	A		5541841	5541842
TCF050204BPV34	5,07	.200	2,40	.094	5,40	.213	2,40	.094	0,400	.015	B		5542608	5542609
TCF070306CPV34	6,67	.263	2,60	.102	7,10	.280	2,80	.110	0,600	.023	C		5542648	5542646
TCF080308DPV34	8,08	.318	2,80	.110	8,60	.339	3,00	.118	0,800	.031	D		5538600	5538558
TCF100408EPV34	9,96	.392	3,40	.134	10,60	.417	3,60	.142	0,800	.031	E		5538608	5538609
TCF120412FPV34	12,59	.496	4,80	.189	13,40	.528	4,20	.165	1,200	.046	F		5542627	5542628
TCF150512GPV34	15,13	.596	6,00	.236	16,10	.634	5,40	.213	1,200	.046	G		5542479	5542600
TCF180614HPV34	18,04	.710	7,50	.295	19,20	.756	6,50	.256	1,400	.054	H		5542006	5542007

NOTE: For application-specific insert selection, please refer to the application data on pages F92–F95 in the Technical Data Catalog.
SSC = Pocket Seat Reference. To correspond with the SSC on the toolholder.



FOR MORE INFORMATION ON THE PRODUCTS SHOWN, PLEASE SEE PAGES F80–F95 OF THE TECHNICAL CATALOG.

THE ALL-STAR PROGRAM FEATURES ONLY THE MOST POPULAR PLATFORMS, GRADES, AND SIZES.
FOR THE COMPLETE OFFERING, VISIT WIDIA NOVO™ OR WIDIA.COM.

TC4 • Periphery Inserts • V36

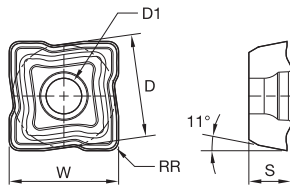
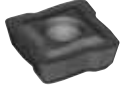



























- first choice
- alternate choice

P	<input checked="" type="checkbox"/>	<input type="checkbox"/>	<input type="checkbox"/>
M	<input type="checkbox"/>	<input type="checkbox"/>	<input type="checkbox"/>
K	<input type="checkbox"/>	<input type="checkbox"/>	<input type="checkbox"/>
N	<input type="checkbox"/>	<input type="checkbox"/>	<input type="checkbox"/>
S	<input type="checkbox"/>	<input type="checkbox"/>	<input type="checkbox"/>
H	<input type="checkbox"/>	<input type="checkbox"/>	<input type="checkbox"/>

catalog number	D		D1		W		S		RR		SSC	WU25CH	WU40PH
	mm	in	mm	in	mm	in	mm	in	mm	in			
TCF040204APV36	4,14	.163	2,10	.083	4,40	.173	2,00	.079	0,400	.015	A	5541845	
TCF050204BPV36	5,07	.200	2,40	.094	5,40	.213	2,40	.094	0,400	.015	B	5542621	5542622
TCF070306CPV36	6,67	.263	2,60	.102	7,10	.280	2,80	.110	0,600	.023	C	5542649	5542650
TCF080308DPV36	8,08	.318	2,80	.110	8,60	.339	3,00	.118	0,800	.031	D	5538601	5538602
TCF100408EPV36	9,96	.392	3,40	.134	10,60	.417	3,60	.142	0,800	.031	E	5538611	5538612
TCF120412FPV36	12,59	.496	4,80	.189	13,40	.528	4,20	.165	1,200	.046	F	5542640	5542641
TCF150512GPV36	15,13	.596	6,00	.236	16,10	.634	5,40	.213	1,200	.046	G	5542603	5542605
TCF180614HPV36	18,04	.710	7,50	.295	19,20	.756	6,50	.256	1,400	.054	H	5542020	

NOTE: For application-specific insert selection, please refer to the application data on pages F92–F95 in the Technical Data Catalog.
SSC = Pocket Seat Reference. To correspond with the SSC on the toolholder.

Holemaking Icons

 Drilling	 Drilling: Inclined Entry	 Drilling: Inclined Exit	 Drilling: Exit Offset	 Drilling: Stacked Plates
 Drilling: Convex	 Drilled Hole	 Chain Drilling	 Drilling: Cross Hole	 Drilling: Half Cylinder
 Drilling: Corner Drilling 45°	 Drilling Depth: 2x	 Drilling Depth: 3x	 Drilling Depth: 4x	 Drilling Depth: 5x
 Drilling Depth: 8x	 Shank: Cylindrical Plain	 Shank: Cylindrical Plain ≤h6	 Flat Shank	 Shank: Cylindrical with Flat
 Helix Angle 30°	 DIN 6537	 DIN 6535	 Through Coolant: Radial: Drilling	 Flood Coolant: Drilling
 Through Coolant: Radial: Indexable Drilling	 Tool Dimensions: 2-Flute/2-Margin/ Coolant			

ANSI

P Steel	K Cast Iron	S High-Temp Alloys
M Stainless Steel	N Non-Ferrous	H Hardened Materials

material group	description	content	tensile strength RM (MPa)*	hardness (HB)	hardness (HRC)	material number
P0	Low-Carbon Steels, Long Chipping	C <0,25%	<530	<125	–	A36, 1008, 1010, 1018 through 1029; 1108, 1117
P1	Low-Carbon Steels, Short Chipping, Free Machining	C <0,25%	<530	<125	–	10L18, 1200 Series, 1213, 12L14
P2	Medium- and High-Carbon Steels	C >0,25%	>530	<220	<25	1035, 1045, 10L45, 1050, 10L50, 1080, 1137, 1144, 11L44, 1525, 1545, 1572
P3	Alloy Steels and Tool Steels	C >0,25%	600–850	<330	<35	1300, 2000, 3000, 4000, 5000, 8000, P20, SAE: A, D, H, O, S, M, T
P4	Alloy Steels and Tool Steels	C >0,25%	850–1400	340–450	35–48	1300, 2000, 3000, 4000, 5000, 8000, P20, SAE: A, D, H, O, S, M, T
P5	Ferritic, Martensitic, and PH Stainless Steels	–	600–900	<330	<35	15–5 PH, 13–8 PH, 17–4 PH, 400 and 500 Series
P6	High-Strength Ferritic, Martensitic, and PH Stainless Steels	–	900–1350	350–450	35–48	15–5 PH, 13–8 PH, 17–4 PH, 400 and 500 Series
M1	Austenitic Stainless Steel	–	<600	130–200	–	200 Series, 301, 302, 304, 304L, 309
M2	High-Strength Austenitic Stainless and Cast Stainless Steels	–	600–800	150–230	<25	310, 316, 316L, 321, 347, 384 ASTM Cast XM-1, XM-5, XM-7, XM-21
M3	Duplex Stainless Steel	–	<800	135–275	<30	323, 329, F55, 2205, S329000
K1	Grey Cast Iron	–	125–500	120–290	<32	class 20, 25, 30, 35, 40, 45, 50, 55, 60, G1800, G3000, G3500, G4000
K2	Low- and Medium-Strength Ductile Irons (Nodular Irons) and Compacted Graphite Irons (CGI)	–	<600	130–260	<28	60-40-18, 65-45-12, 80-55-06, SAE J434:D4018, D4512, D5506, ASTM A47: Grade 32510, 35018, SAE J158: Grade M3210, M4504, M5003, M5503, M7002, ASTM A842: Grade 250, 300, 350, 400, 450
K3	High-Strength Ductile Irons and Austempered Ductile Iron (ADI)	–	>600	180–350	<43	ASTM A536:100-70-03, 120-90-02, SAE J434: D7003, SAE J158: Grade M8501AST A897: 125-80-10, 150-100-7, 175-125-4, 200-150-1, 230-185
N1	Wrought Aluminum	–	–	–	–	2025, 5050, 7050, 1000, 2017
N2	Low-Silicon Aluminum Alloys and Magnesium Alloys	Si <12,2%	–	–	–	2024, 6061, 7075
N3	High-Silicon Aluminum Alloys and Magnesium Alloys	Si >12,2%	–	–	–	–
N4	Copper-, Brass-, Zinc-Based on Machinability Index Range of 70–100	–	–	–	–	C81500
N5	Nylon, Plastics, Rubbers, Phenolics, Resins, Fiberglass	–	–	–	–	–
N6	Carbon, Graphite Composites, CFRP	–	–	–	–	Graphite, CFK, CFRP
N7	Metal Matrix Composites (MMC)	–	–	–	–	C63000
S1	Iron-Based, Heat-Resistant Alloys	–	500–1200	160–260	25–48	A-286, INCOLOY® 800 Series, A608, A567, Inconel™, INVAR®, N-155, 16-25-6, 19-9 DL; Cast: ASTM A-297, A-351, A-567, A-608
S2	Cobalt-Based, Heat-Resistant Alloys	–	1000–1450	250–450	25–48	Haynes® 25 (L605), Haynes 188, J-1570, Stellite, AiResist 213; Cast: AiResist 13, Haynes 21, MAR-M302, MAR-M509, NASA Co-W-Re, WI-52
S3	Nickel-Based, Heat-Resistant Alloys	–	600–1700	160–450	<48	Astroloy™, Hastelloy® B/C/ C-276 /X, INCONEL® 600 and 700 Series, IN102, INCOLOY 900 Series, Rene 41, Waspalloy®, Monel®, K-500, MAR-M20, NIMONIC®, UDIMET®
S4	Titanium and Titanium Alloys	–	900–1600	300–400	33–48	Pure: Ti 98.8, Ti 98.9, Ti 99.9; Alloyed: Ti 5Al-2.5Sn, Ti6Al-4V, Ti6Al-2Sn-4Zr-2Mo, Ti-3Al-8V-6Cr-4Mo-4Zr, Ti-10V-2Fe-3Al, Ti-13V-11Cr-3Al
H1	Hardened Materials	–	–	–	44–48	Tool Steel H10, H11, H13, D2, D3, 4340, P20
H2	Hardened Materials	–	–	–	48–55	Tool Steel H10, H11, H13, D2, D3, 4340, P20
H3	Hardened Materials	–	–	–	56–60	Tool Steel H10, H11, H13, D2, D3, 4340, P20
H4	Hardened Materials	–	–	–	>60	Tool Steel H10, H11, H13, D2, D3, 4340, P20

Material Overview • DIN

DIN

P Steel	K Cast Iron	S High-Temp Alloys
M Stainless Steel	N Non-Ferrous	H Hardened Materials

material group	description	content	tensile strength RM (MPa)*	hardness (HB)	hardness (HRC)	material number
P0	Low-Carbon Steels, Long Chipping	C <0,25%	<530	<125	–	–
P1	Low-Carbon Steels, Short Chipping, Free Machining	C <0,25%	<530	<125	–	C15, Ck22, ST37-2, S235JR, 9SMnPb28, GS38
P2	Medium- and High-Carbon Steels	C >0,25%	>530	<220	<25	ST52, S355JR, C35, GS60, Cf53
P3	Alloy Steels and Tool Steels	C >0,25%	600–850	<330	<35	16MnCr5, Ck45, 21CrMoV5-7, 38SMn28
P4	Alloy Steels and Tool Steels	C >0,25%	850–1400	340–450	35–48	100Cr6, 30CrNiMo8, 42CrMo4, C70W2, S6525, X120Mn12
P5	Ferritic, Martensitic, and PH Stainless Steels	–	600–900	<330	<35	100Cr6, 30CrNiMo8, 42CrMo4, C70W2, S6525, X120Mn12
P6	High-Strength Ferritic, Martensitic, and PH Stainless Steels	–	900–1350	350–450	35–48	X102CrMo17, G-X120Cr29
M1	Austenitic Stainless Steel	–	<600	130–200	–	X5CrNi 18 10, X2CrNiMo 17 13 2, G-X25CrNiSi18 9, X15CrNiSi 20 12
M2	High-Strength Austenitic Stainless and Cast Stainless Steels	–	600–800	150–230	<25	X2CrNiMo 13 4, X5NiCr 32 21, X5CrNiNb 18 10, G-X15CrNi 25-20
M3	Duplex Stainless Steel	–	<800	135–275	<30	X8CrNiMo27 5, X2CrNiMoN22 5 3, X20CrNiSi25 4, G-X40CrNiSi27 4
K1	Gray Cast Iron	–	125–500	120–290	<32	GG15, GG25, GG30, GG40, GTW40
K2	Low- and Medium-Strength Ductile Irons (Nodular Irons) and Compacted Graphite Irons (CGI)	–	<600	130–260	<28	GGG40, GTS35
K3	High-Strength Ductile Irons and Austempered Ductile Iron (ADI)	–	>600	180–350	<43	GGG60, GTW55, GTS65
N1	Wrought Aluminum	–	–	–	–	AlMg1, Al99.5, AlCuMg1, AlCuBiPb, AlMgSi1, ALMg-SiPb
N2	Low-Silicon Aluminum Alloys and Magnesium Alloys	Si <12,2%	–	–	–	GAISiCu4, GDAISi10Mg
N3	High-Silicon Aluminum Alloys and Magnesium Alloys	Si >12,2%	–	–	–	G-ALSi12, G-AISi17Cu4, G-AISi21CuNiMg
N4	Copper-, Brass-, Zinc-Based on Machinability Index Range of 70–100	–	–	–	–	CuZn40, Ms60, G-CuSn5ZnPb, CuZn37, CuSi3Mn
N5	Nylon, Plastics, Rubbers, Phenolics, Resins, Fiberglass	–	–	–	–	Lexan®, Hostalen™, Polystyrol, Makralon®
N6	Carbon, Graphite Composites, CFRP	–	–	–	–	CFK, GFK
N7	Metal Matrix Composites (MMC)	–	–	–	–	–
S1	Iron-Based, Heat-Resistant Alloys	–	500–1200	160–260	25–48	X1NiCrMoCu32 28 7, X12NiCrSi36 16, X5NiCrAlTi31 20, X40CoCrNi20 20
S2	Cobalt-Based, Heat-Resistant Alloys	–	1000–1450	250–450	25–48	Haynes® 188, Stellite® 6,21,31
S3	Nickel-Based, Heat-Resistant Alloys	–	600–1700	160–450	<48	INCONEL® 690, INCONEL 625, Hastelloy®, Nimonic® 75
S4	Titanium and Titanium Alloys	–	900–1600	300–400	33–48	Ti1, TiAl5Sn2, TiAl6V4, TiAl4Mo4Sn2
H1	Hardened Materials	–	–	–	44–48	GX260NiCr42, GX330NiCr42, GX300CrNiSi952, GX300CrMo153, Hardox® 400
H2	Hardened Materials	–	–	–	48–55	–
H3	Hardened Materials	–	–	–	56–60	–
H4	Hardened Materials	–	–	–	>60	–

ONE SOURCE, MANY APPLICATIONS

WIDIA™ APPROVED TAP/DRILL COMBINATIONS:

VariDrill™/VariTap™



Versatile:

VariDrill™ drilling tools, in combination with VariTap™ tapping tools, are designed for productivity in an array of different materials. These tools feature strong geometries that are ideal for small-batch and varied production.

TOP DRILL S™/GT Series



TDS401
TDS402
TDS403

GT00, 20, 24
Spiral Point
GT30, 32, 50
Spiral Flute
GT23, 24, 25
Forming



TDS451
TDS452
TDS453

GT20
GT30



TDS411
TDS412
TDS413

GT40
GT41



TDS421
TDS422

GT70
GT80
GT22
GT40



TDS451
TDS452
TDS453

GT60
GT90
GT62
GT92



Optimized:

TOP DRILL S™ drills, combined with GT Series Taps: This combination is designed for, but not limited to, material-specific applications with medium to large batch production.

For more than 90 years, WIDIA has defined excellence in innovation, technology, and customer service. As an industry-leading manufacturer of cutting tools, WIDIA offers a complete portfolio of precision-engineered products. With drilling, tapping and tooling systems products, you will find everything you need from one single source.

- Extensive Portfolio
- Expertise
- Customized Solutions

Find your Local WIDIA Authorized Distributor

WIDIA™ brand cutting tools are available exclusively through a specialized network of Authorized Distributor partners whom you can count on to deliver much more than products. Our distributors know us, and more importantly, they know you. They know better than anyone in the industry how to put the global power of WIDIA to work for you — in your industry, in your region, and for your business.

WIDIA distributor partners provide technical expertise that you can count on. They will show you how to:

- Significantly reduce cycle time.
- Improve machine tool utilization.
- Achieve measurable productivity improvements.
- Take advantage of proven supply chain solutions.
- Access local inventory and best-in-class technical support.
- Request onsite demonstrations of the latest tooling technology.

And with thousands of turning, milling, holemaking, tapping, and tooling systems products available from WIDIA, you'll find everything you need from one single source.



Find your Local WIDIA Authorized Distributor by accessing our distributor finder at widia.com.

IMPORTANT SAFETY INSTRUCTIONS: READ BEFORE USING THE TOOLS IN THIS CATALOG

METALCUTTING SAFETY

Projectile and Fragmentation Hazards

Modern metalcutting operations involve high spindle and cutter speeds and high temperatures and cutting forces. Hot metal chips may fly off the workpiece during metalcutting. Although cutting tools are designed and manufactured to withstand high cutting forces and temperatures, they can sometimes fragment, particularly if they are subjected to over-stress, severe impact, or other abuse.

To avoid injury:

- Always wear appropriate personal protective equipment, including safety goggles, when operating metalcutting machines or working nearby.
- Always make sure all machine guards are in place.

For more information, read the applicable Material Safety Data Sheet provided by WIDIA and consult General Industry Safety and Health Regulations, Part 1910, Title 29 of the Code of Federal Regulations.

These safety instructions are general guidelines. Many variables affect machining operations. It is impossible to cover every specific situation. The technical information included in this catalog and recommendations on machining practices may not apply to your particular operation.

For more information, consult the WIDIA Metalcutting Safety booklet, available free from WIDIA at +1 724 539 5747 or fax +1 724 539 5439. For specific product safety and environmental questions, contact our Corporate Environmental Health and Safety Office at +1 724 539 5066 or fax +1 724 539 5372.

Breathing and Skin Contact Hazards

Grinding carbide or other advanced cutting tool materials produces dust or mist containing metallic particles. Breathing this dust or mist — especially over an extended period — can cause temporary or permanent lung disease or make existing medical conditions worse. Contact with this dust or mist can irritate eyes, skin, and mucous membranes and may make existing skin conditions worse.

To avoid injury:

- Always wear breathing protection and safety goggles when grinding.
- Provide ventilation control and collect and properly dispose of dust, mist, or sludge from grinding.
- Avoid skin contact with dust or mist.

NOVO, Stellite, Top Cut 4, TOP DRILL, TOP DRILL M1, TOP DRILL S, VariDrill, VariTap, WIDIA, and WU25PD are trademarks of Kennametal, Inc. and are used as such herein. The absence of a product, service name, or logo from this list does not constitute a waiver of Kennametal's trademark or other intellectual property rights concerning that name or logo.

Astroloy™ is a trademark of Svedala Industries, Inc. Corporation.

Discaloy™ is a trademark of Westinghouse Electric Corporation.

Hardox® is a registered trademark of SSAB Technology AB Corporation.

Hastelloy® and Haynes® is a registered trademarks of Haynes International, Inc. Corporation.

Hostalen® is a registered trademark of HOECHST GMBH.

INCOLOY® is a registered trademark of Inco Alloys International, Inc.

INCONEL®, NIMONIC®, Monel®, and UDIMET® are registered trademarks of Special Metals Corporation.

INVAR® is a registered trademark of Imphy Alloys Joint Stock Company.

Weldon® is a registered trademark of Weldon Tool Company.

©Copyright 2019 by Kennametal Inc., Latrobe, PA 15650. All rights reserved.

WIDIA 



VOL 1

WORLD HEADQUARTERS

WIDIA Products Group

Kennametal Inc.
1600 Technology Way
Latrobe, PA 15650 USA
Tel: 1 800 979 4342
w-na.service@widia.com

EUROPEAN HEADQUARTERS

WIDIA Products Group

Kennametal Europe GmbH
Rheingoldstrasse 50
CH 8212 Neuhausen am Rheinfall
Switzerland
Tel: +41 52 6750 100
w-ch.service@widia.com

ASIA-PACIFIC HEADQUARTERS

WIDIA Products Group

Kennametal (Singapore) Pte. Ltd.
3A International Business Park
Unit #01-02/03/05, ICON@IBP
Singapore 609935
Tel: +65 6265 9222
w-sg.service@widia.com

INDIA HEADQUARTERS

WIDIA Products Group

Kennametal India Limited
CIN: L27109KA1964PLC001546
8/9th Mile, Tumkur Road
Bangalore - 560 073
Tel: +91 80 2839 4321
w-in.service@widia.com



COMPLETE METALWORKING SOLUTIONS

(800) 991-4225

www.ahbinc.com

ISO Certified

customerservice@ahbinc.com



widia.com