

TAP INTO OUR EXPERTISE

INTERACTIVE WIDIA PRODUCT GUIDE

WIDIA ™



AHB
TOOLING & MACHINERY, INC.
COMPLETE METALWORKING SOLUTIONS

ISO CERTIFIED
(800) 991-4225

WWW.AHBINC.COM

CUSTOMERSERVICE@AHBINC.COM



COMPLETE METALWORKING SOLUTIONS

MICHIGAN'S FULL-SERVICE WIDIA DISTRIBUTOR

AHB Tooling & Machinery is your go-to resource for metalworking in Michigan. Our customers rely on us for exceptional service and top-notch product expertise—especially when it comes to Widia milling, tapping, drilling and tooling products! We carry every Widia product you need and can also help you with custom orders!

Please take a look at this exciting new interactive product guide. It provides a quick overview of some of our most popular Widia products. Better yet, it provides you with links to more information, including product videos to help you make better decisions and **get the details you need FAST!**

And...with your customer login detail...you can even place product orders!

Don't see what you need? You can always call your AHB Metalworking Specialist to help you with any Widia product decision at **800-991-4225!** Or customer service is only an email way at customerservice@ahbinc.com.



TABLE OF CONTENTS

Solid End Milling	3
GP (General Purpose) End Mills	4
Varitap™ High Performance Taps	5-7
Indexable Milling	8-9
Face Mills	10
Widia Product Information Library	11



SOLID END MILLING

WIDIA™ HANITA™

[CLICK HERE TO ORDER
VARIMILL II END MILLS](#)

As an industry-leading manufacturer of carbide round tools, WIDIA-Hanita offers a complete solid carbide end mill portfolio of precision-engineered products with solutions for a wide range of workpiece materials.



VariMill II™ ER

Like the VariMill II, VariMill II ER end mills are engineered with five unequally spaced flutes. However, unlike with the existing VariMill product line, the eccentric relief (ER) available with this new tool's cutting edges provides greater edge strength and enables high feeds and metal removal rates. The VariMill II ER end mill has a different taper core than VariMill I and II for increased stability and robust performance, and also differs from its predecessors in that it is designed for center cutting.

VariMill II ER also is the first off-the-shelf tool to offer SAFE-LOCK™ by Haimer, which provides excellent stability, eliminates pull-out risk, and makes the tool more stable and concentric, overall. SAFE-LOCK is available on tools >1/2" (12mm) in diameter.

More than 100 VariMill II ER standard line items will be available globally in diameters from 3/8-1" (10-25mm). Though primarily designed for roughing and finishing applications in the aerospace industry, VariMill II ER tools can be used as a solution for any titanium or stainless-steel machining and are capable of slotting, ramping, and plunging.



[CLICK HERE FOR A SHORT VIDEO](#)

WIDIA™ HANITA™

[CLICK HERE TO ORDER
VARIMILL III END MILLS](#)

VariMill III™ ER

Following the success of WIDIA's VariMill I™ and VariMill II™ end mills, the new VariMill III ER™ end mill offers the superior performance of its predecessors with added features that enhance stability. Due to its success as a popular and effective custom solution, WIDIA™ now is making the VariMill III ER end mill available as an option in its standard product portfolio. Bringing this option to the standard portfolio provides customers with fast and easily accessible ordering options worldwide.

High-Performance Solid Carbide End Mills • VariMill™
Series 771E 772E • VariMill III™ ER • Victory™ Grades

FEATURES AND BENEFITS:

- Unequal flute spacing
- Center cutting
- Ramping angle 3°
- Optimized for difficult-to-machine work piece materials
- Semi-finishing to finishing applications
- High-speed machining capability
- Standard items listed. Additional styles and coatings made to order

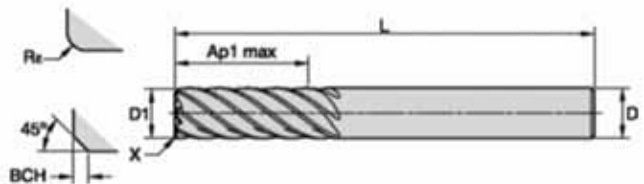

SOLID END MILLING

WIDIA HANITA

[CLICK HERE TO ORDER
VARIMILL II GP END MILLS](#)

VariMill GP is a portfolio of multi-purpose end mills suitable for roughing, semi-finishing, and finishing in an expanded range of work materials (aluminum, steels, stainless steels, and cast irons). The key benefits to manufacturing companies include reduced inventory and tool management on your machine tools as one tool covers roughing and finishing; lower tool costs due to long tool life at value pricing; and ease of reconditioning to keep the production flowing. With all these advantages, WIDIA is truly a one-stop shop for the most value in solid-carbide end mills.

Consisting of two- and four-flute versions in square-end, chamfered-edge, and ball-nose configurations, VariMill GP end mills prove their performance increases through advanced design features. A 30-degree helix angle and eccentric relief provides strong edges and stability for roughing, semi-finishing, and finishing with the same tool. A thick TiAlN coating contributes to extended tool life across steel, stainless steel, and cast iron workpieces and milling, ramping, or slotting operations.

VariMill GP mills are available in inch and metric sizes along with varying lengths and shank styles. Customers looking to handle more work across more materials will do well to increase their flexibility and lower their costs with these truly multi-function, long-life, general-purpose mills.



[CLICK HERE FOR A SHORT VIDEO](#)

WIDIA HANITA

[CLICK HERE TO ORDER
DV40 DUO-LOCK](#)

DV40 DUO-LOCK™ INTEGRATED MACHINE SLIDE ADAPTOR

VariMill Modular combines highest runout accuracy and length repeatability with maximum coupling stability. This allows the VariMill Modular system to utilize the full potential of WIDIA™ VariMill cutting geometries and WIDIA Victory™ grades. The flexible VariMill Modular system targets applications like solid carbide end mills. A wide range of diameters between 3/8–1-1/4" (10–32mm) and multiple corner configurations, such as sharp chamfer and radii, are available from stock.



[CLICK HERE FOR A SHORT VIDEO](#)

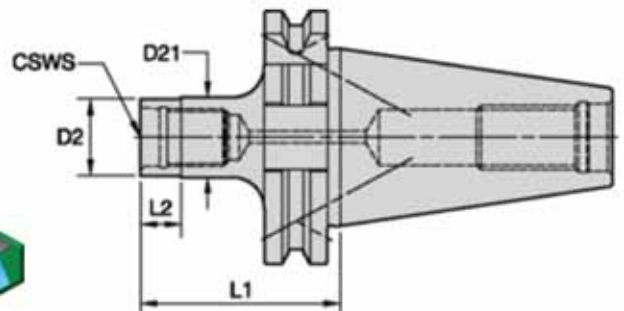

TAPPING

WIDIA™ GTD 

[CLICK HERE TO ORDER
WIDIA GTD TAPS](#)

SPIRAL-POINT AND LEFT-HAND SPIRAL-FLUTE

Hole Applications Solutions for
Through Hole Applications

- Steel and steel alloys
- Stainless steel
- Wrought and cast aluminum
- Cast iron
- Nickel-based alloys
- Titanium alloys



High-Performance Victory™ HSS-E-PM Taps

- Left-hand spiral flutes to push chips ahead in through holes
- Offer performance advantages over conventional high-speed steel taps
- Long tap life at up to 50% higher tapping speed than HSS taps

SERIES: GT20, GT21, GT10, GT90, GT14, GT60, GT70, GT72, GT00

Multipurpose VariTap™

- Unique spiral-point geometry provides low tapping torque while pushing chips ahead of the tap in through holes
- Manufactured from high-vanadium HSS-E to provide long and consistent tool life
- Ideal for customers who have a variety of materials to machine

SERIES: VTSP050, VTSP055, VTSP075, VTSP090, VTSP095, VTSP054, VTSP097, VTSP099, 5601, VTSP060, VTSP065



[CLICK HERE FOR
A SHORT VIDEO](#)

SPIRAL FLUTE

Solutions for Blind Hole Applications

- Steel and steel alloys
- Stainless steel
- Cast iron
- Wrought and cast aluminum
- Nickel-based alloys
- Titanium alloys



High-Performance Victory™ HSS-E-PM Taps

- Optimized spiral-flute design enables deep blind holes to be threaded
- Offer performance advantages over conventional high-speed steel taps
- Long tap life at up to 50% higher tapping speed than HSS taps

SERIES: GT30, GT31, GT32, GT33, GT50, GT51, GT12, GT92, GT94, GT16, GT62, GT80, GT82, GT86, GT02, GT04

Multipurpose VariTap™

- Spiral-flute geometry optimized to provide efficient chip ejection in blind holes
- Manufactured from high-vanadium HSS-E to provide long and consistent tool life
- Geometry designed to allow tapping of a wide variety of ductile materials: carbon and alloy steels, stainless steels, ductile iron, and cast aluminum
- Ideal for customers who have a variety of materials to machine

SERIES: VTSFT50, VTSFT51, VTSFT90, VTSFT97, VTSFT60, VTSFT55, VTSFT65, VTSFT95, VTSFT99, VTSFT75, VTSFT54, 5344

TAPPING

WIDIA™ GTD

STRAIGHT FLUTE

Solutions for Through and Blind Hole Applications

- Steel and steel alloys
- Stainless steel
- Cast iron
- Aluminum



High-Performance Victory™ Solid Carbide Taps

- Straight flute designed for outstanding tool life in cast iron, aluminum, and hardened materials
- Manufactured with fine-grain micrograin carbide for exceptional wear life
- Ideal for long production runs where fewer tool changes mean greater productivity
- Runs up to 4x faster and lasts up to 4x longer than conventional high-speed steel taps
- Excellent thread quality and tap performance

High-Performance Victory™ HSS-E-PM Taps

- Straight-flute taps store chips in hole or are flushed out with internal coolant
- Manufactured from powdered metal high-speed steel coated for thread cutting in cast iron and aluminum
- Offer performance advantages over conventional high-speed steel taps
- Long tap life at up to 50% higher tapping speed than HSS taps

SERIES: GX10, GX35, GX47, GX50, GT40, GT41, GT42, GT43, GT06

FORMING TAPS

Solutions for Forming Threads in Through and Blind Hole Applications

- Steel and steel alloys
- Stainless steel
- Aluminum



High-Performance Victory™ Solid Carbide Taps

- Advanced forming geometries designed for superior tap performance in aluminum
- Manufactured with fine-grain micrograin carbide for exceptional wear life
- Ideal for long production runs where fewer tool changes mean greater productivity
- Runs up to 4x faster and lasts up to 4x longer than conventional high-speed steel taps
- Excellent thread quality and tap performance

High-Performance Victory™ HSS-E-PM Taps

- Manufactured from powdered metal high-speed steel coated for thread forming in steel, stainless steel, and aluminum
- High hardness provides superior wear resistance
- Offer performance advantages over conventional high-speed steel taps
- Long tap life at up to 50% higher tapping speed than HSS taps
- Standard coolant-fed options for longer tool life

SERIES: GX49, GT22, GT23, GT24, GT25, GT26, GT27

[CLICK HERE TO ORDER
GTD TAPS](#)

TAPPING

WIDIA™ GTD 



Tap into the Power of the Original

WIDIA-GTD™ is built on a strong foundation of over 100 years of experience. Our rich history enables us to continue to deliver the most advanced solutions in the market to our diverse audiences.

WIDIA-GTD represents the powerful combination of speed and precision matched with high performance, consistent quality, and relentless innovation.

Metalworking's oldest — and most trusted — brand.

PIPE TAPS

Solutions for Pipe Thread Applications

- Steel and steel alloys
- Stainless steel
- Cast iron
- Aluminum
- Brass

Multipurpose VariTap™

- Slow helix spiral-flute design for tapping steel and stainless steel
- Straight-flute design for tapping mold steels and cast iron
- NPT and NPTF thread forms with standard projections and chamfers
- Manufactured from high-vanadium HSS-E to provide long and consistent life
- Ideal for customers who have a variety of materials to machine

SERIES: VTSFT80, VTSTR



[CLICK HERE TO ORDER
GTD TAPS](#)

INDEXABLE MILLING

VICTORY SHOULDER MILLING

The unique design of the VSM11, VSM17, VSM490-10 and VSM490-15 is capable of producing a true 0 degree wall in multiple material types. When combined with the latest WIDIA Victory grades VSM provides superior performance at high speeds.

[CLICK HERE TO ORDER VICTORY SHOULDER MILLS](#)



[CLICK HERE FOR A SHORT VIDEO](#)

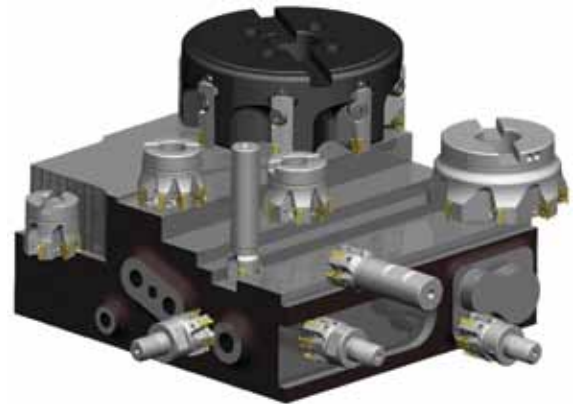

VSM490 – THE ULTIMATE SHOULDER MILLING SOLUTION FOR STEP-DOWN APPLICATIONS

WIDIA victory shoulder milling series is specifically engineered to achieve excellent surface quality as well as higher material removal rates in shoulder milling applications. The VSM490 series enables the tool to be applied in multiple passes with outstanding results.

VSM490-10

4-Edged, 0° Victory™ Shoulder Mill True 0° roughing tool with embedded finishing capabilities all in one tool. For the same diameter, you can load more inserts and receive a higher table feed with VSM490-10.

FEATURES:

- Up to $A_{p1} \text{ max} = .394''$
- Best-in-class wall finish in axial stepping-down jobs
- Lower cutting forces and real soft cutting action
- Perfect fit for taper 40 spindles and driven units



VSM490-15

4-Edged, 0° Victory™ Shoulder Mill True 0° roughing tool with embedded finishing capabilities all in one tool.

FEATURES:

- Up to $A_{p1} \text{ max} = .591''$
- Best-in-class wall finish in axial stepping-down jobs
- Lower cutting forces and real soft cutting action
- Perfect fit for taper 50 spindles
- Coarse, medium, and fine pitch shell mills available



INDEXABLE MILLING

VICTORY SHOULDER MILLING

[CLICK HERE TO ORDER
VICTORY SHOULDER MILLS](#)

VSM11

- 2-Edged, 0° Victory™ Shoulder Mill • True 0° shoulder milling platform; up to A_{p1} max = .453"
- Aggressive ramping capability up to 12.5° with end mills with a diameter of .625"
- Optimized chip gash for improved cutter stability and chip flow
- Well-guided internal coolant supply to the cutting edge.
- Best-in-class milling grade WS40PM boosts productivity when machining stainless steel and high-temp alloys



[CLICK HERE FOR A SHORT VIDEO](#)



VSM17

- 2-Edged, 0° Victory™ Shoulder Mill
- True 0° shoulder milling platform; up to A_{p1} max = .638"
- Aggressive ramping capability up to 8.5° with end mills with a diameter of 1"
- Optimized chip gash for improved cutter stability and chip flow
- Well-guided internal coolant supply to the cutting edge
- Best-in-class milling grade WS40PM boosts productivity when machining stainless steel and high-temp alloys

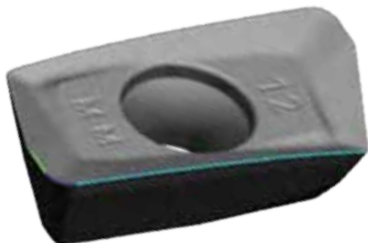

FACE MILLS

SUPERFEED

Our unique insert design delivers exceptional stability and performance. Reduced complexity with exceptional finishing capabilities make SuperFeed the go-to platform in aluminum and non-ferrous face and end milling applications.



[CLICK HERE TO ORDER FACE MILLS](#)

VICTORY M1200HR AND M1200 MINI FACE MILL

Best-in-class face milling platform to boost productivity on taper 50 spindle milling machines. Featuring Twelve cutting edges and High feed rates for rough face milling.



[CLICK HERE FOR A SHORT VIDEO](#)

M200

Features our double-sided round carbide inserts with up to 12 effective cutting edges. Capable of running in multiple types of milling operations and workpiece materials, increases customers' productivity with the most efficient cost per edge.

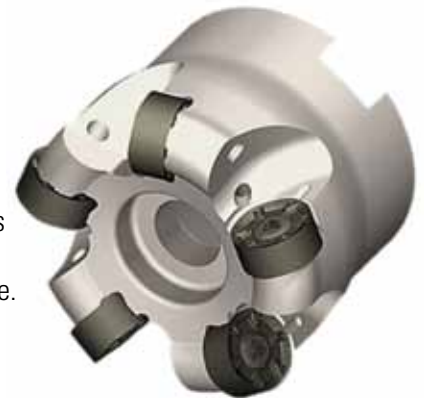

M370

Designed for high feed rate productivity, the M370 Series provides the latest insert technology with outstanding performance and reliability. Its double-sided concept and six cutting edges provide security and optimal metal removal with an efficient cost per edge.



[CLICK HERE FOR A SHORT VIDEO](#)

WIDIA PRODUCT INFORMATION LIBRARY



2017 Master Catalog

WIDIA 



WIDIA 



YouTube

WIDIA 

CLICK HERE TO FOR A COMPLETE LIST OF WIDIA VIDEOS!

As metalworking's oldest - and most trusted - brand, WIDIA™ offers a complete portfolio of precision-engineered products and custom solution services. This group of WIDIA product videos demonstrates exceptional performance at unsurpassed speeds and feeds in the most demanding applications.

(800) 991-4225 | www.AHBinc.com | CustomerService@AHBinc.com

