

AHBANKI®

OIL SKIMMERS

COOLANT MAINTENANCE CATALOG



A comprehensive guide for solutions to coolant and tramp oil maintenance from the world's most trusted oil skimming brand.

The world leader in oil skimming technologies.



Skimmerman™

AHB

TOOLING & MACHINERY

COMPLETE
METALWORKING
SOLUTIONS

(800) 991-4225

www.ahbinc.com

ISO Certified

customerservice@ahbinc.com

Removing Oil From Water in the Shop

Companies look for effective ways to remove oil from water or coolant to reduce costs and the liability of proper disposal. Another reason for removing the oil is a better work environment. Letting oil remain in the coolant tank allows anaerobic bacteria to grow. Anaerobic bacteria break down the components of coolant, causing it to need changing more frequently. Oil-laden coolant with a high anaerobic bacteria content has two other drawbacks as well. The first drawback is an unpleasant odor caused by the bacteria. The second drawback the smoke generated from the oil-laden coolant coming in contact with the operating cutting tool. One of the easiest ways to remove hydrocarbons from water or coolant is by using a belt oil skimmer. It is a low maintenance, easy to use tool for removing oil from water or coolant.

Belt oil skimmers work because of the differences in specific gravity between oil and water. Water has a specific gravity of one. Most oils have a specific gravity of less than one. Because of these differences, oil floats to the top of the water where it can be removed. A belt oil skimmer uses oil oleophilic material, (usually made of stainless steel or plastic), in the form of a belt to break the surface tension of the water to attract and collect the floating oil. The belt passes through a set of wiper blades via a motorized head pulley where the oil is wiped off both sides of the belt. The oil then flows through the skimmer troughs and into a proper disposal container. Because the belt materials used do not attract water, very little coolant or water is picked up.

Some of the advantages of using a belt oil skimmer over other methods to remove oil are the lower initial cost compared to coalescers and other filtration systems, low maintenance, no filters to change, and no mess involved as with absorbent booms or pads. With an oil skimmer, virtually the only required maintenance is replacing a belt and wiper blade set as needed. Next, Abanaki skimmers require very little operating space, usually with no modification to the tank. Finally, our oil skimmers have pick-up rates of up to 200 gph with minimal water or coolant content. Other forms of oil removal cannot perform as well.



There are many instances where companies have turned their disposal costs into income. By using an Abanaki oil skimmer to remove oil from the coolant, one company was able to sell its used oil to be recycled instead of being charged to have the oil-contaminated coolant disposed of. Another money saving benefit was an extended coolant life resulting in lower coolant and maintenance costs. Because of this, the Abanaki oil skimmer paid for itself in a short period of time.

Abanaki Corporation manufactures a wide variety of oil skimmers to meet any size application. From a small coolant tank in a CNC lathe to a scale pit in a steel mill, Abanaki Corporation can supply a skimmer to do the job. We manufacture skimmers that can remove from 1 gallon per hour to 200 gallons per hour. We offer turnkey systems with a variety of motors, heat options, stands, and oil concentrators. Our skimmers are used on parts washers, in car washes, wells, steel mills, and any other industry where hydrocarbons need to be removed.

Advantages of Using an Oil Skimmer in the Machining Industry

The use of a machine center skimmer holds many benefits including:

Reduction of Disposal Costs: The cost of disposing oil laden coolant is more expensive than the disposing of oil.

Recycling Opportunities: In some instances, companies may be able to re-use the skimmed oil elsewhere or sell it for recycling, choosing to keep their part of the world cleaner.

Extend Coolant Life: Having oil free coolant can also extend its usefulness and effectiveness, reducing the expense on maintenance and coolant replacement.

Esthetic Benefits: Removing the oil from a machine coolant tank will cut down on the amount of smoke generated from the cutting tool coming into contact with oil laden coolant thereby creating a visibly cleaner workplace.

Extend Tool Life: Removing floating surface oils while aerating and refreshing coolant will extend tool life as well.

Avoid EPA Violations: Many machining and metal working shops turn to aqueous parts cleaning because of limits imposed by the EPA on the discharge of emissions and wastes.

Hygienic Benefits: Keeping coolant oxygenated and oil-free reduces the "rotten egg" odor and bacterial levels are lowered resulting in a cleaner work environment.

Mighty Mini® SST Belt Oil Skimmer

The ideal solution to remove unwanted tramp oil in coolants & parts washers! **Effective.** Removes one (1" wide belt) or two (2" wide belt) gallons or more of medium weight oil per hour.

Compact. Use it almost anywhere...even through a 2" dia. bunghole in a drum.

Portable. Use it here today, there tomorrow. Weighs only 7 pounds, installs in seconds and runs on 110v. power. 220v motor available. **Complete.** Put it to work right out of the box, or add the option, easy-to-install decanter and brackets for an even more efficient system.

Durable. Includes long life fan-cooled motor, sturdy 304 stainless steel construction with integrated 24 hour timer. Every Abanaki skimmer is backed as well as it's built. We do it right or you don't pay!

- Fan-cooled motor
- 1" and 2" wide stainless steel or specially-engineered plastic belts
- Both sides of belt are wipes for better efficiency
- 304 stainless steel base and housing
- Spring-loaded stabilizer bar
- 3-foot clear discharge hose and clamp
- 8-foot grounded power cord w/plug
- Integrated 24 hour timer



Optional Cling-On Technology available. Magnetic mounting allows for your skimmer to install with ease, anywhere in your shop!

MODEL	BELT WIDTH	BELT LENGTH
SMMS1-06	1"	6"
SMMS1-12	1"	12"
SMMS1-18	1"	18"
SMMS1-24	1"	24"
SMMS2-06	2"	6"
SMMS2-12	2"	12"
SMMS2-18	2"	18"
SMMS2-24	2"	24"

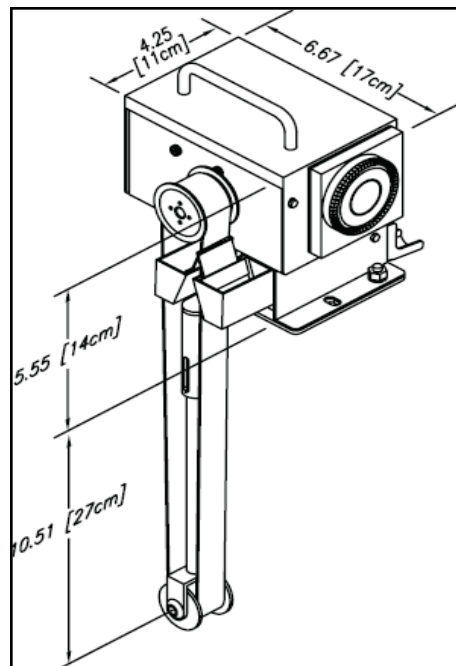

Ultra-Mini Oil Skimmer

The Ultra-Mini is the **smallest skimmer** in the Abanaki product line, weighing only 2.2 pounds. The small footprint makes efficient use of available space... it fits underneath most CNC machines as well as inside parts washers. The compact design allows the Ultra-Mini Oil Skimmer to be concealed anywhere!

This skimmer can be used with **12/24v power**, allowing it to be **wired directly** into the machining center control panels or plugged into an 110v wall outlet. Belt lengths of 8, 12, 18 and 24" are available for this model.



- Stainless Steel construction
- Cogged belt available in 8, 12, 18, and 24" lengths
- Removes oil at rates up to 1 gallon per hour
- 2.2 lbs; smallest/lightest oil skimmer in Abanaki line
- Compact size allows skimmer to be hidden in application
- Can be used with 12/24v power allowing to be wired directly into machining center or into a 110v wall outlet
- Weighted tail pulley prevents belt from slipping during operation
- Extremely affordable even for small business operations



Optional Cling-On Technology available. Magnetic mounting allows for your skimmer to install with ease, anywhere in your

MODEL	BELT WIDTH	BELT LENGTH
SUM-08	1"	8"
SUM-12	1"	12"
SUM-18	1"	18"
SUM-24	1"	24"

Mighty Disk™ Tramp Oil Skimmer

The inexpensive way to remove unwanted tramp oils from CNC coolants and parts washers, but with all the quality that you expect from Abanaki! **Effective.** Removes up to 1 1/2 gallons of oil or more of medium weight oil per hour. **Compact.** Use it almost anywhere a flat surface is available for mounting. **Portable.** Weighs less than 10 pounds, installs in no time, and runs on 110v power. **Complete.** Put it to work right out of the box.



Standard Features:

- Available in 12", 18", and 24" diameters
 - 110v fan-cooled motor
 - High temperature disk material
 - Quality construction

Optional Features:

SS construction with integrate 24 hour timer

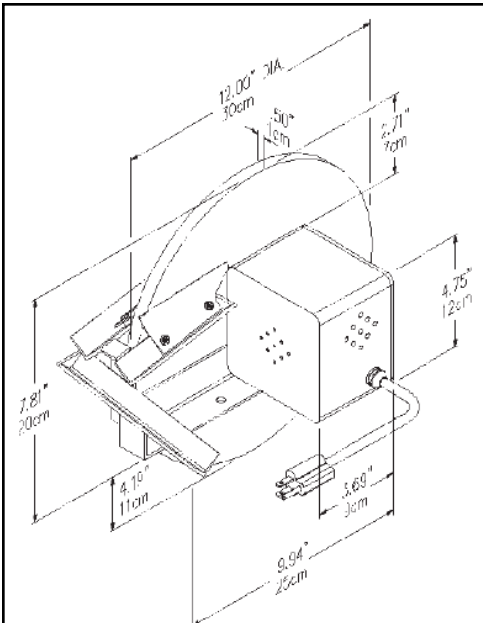

MODEL	DISC DIAMETER
SMD-12	12"
SMD-18	18"
SMD-24	24"



Li'l Blue - Portable Belt Oil Skimmer

- Fan-cooled motor
- 1" oleophilic belts or specially-engineered plastic belts
- Both sides of belt are wiped for better efficiency
- Engineered polymer base and housing
- Spring-loaded stabilizer bar
- 3-foot clear discharge hose and clamp
- 8-foot grounded power cord w/plug
- Stainless steel oil skimming units available

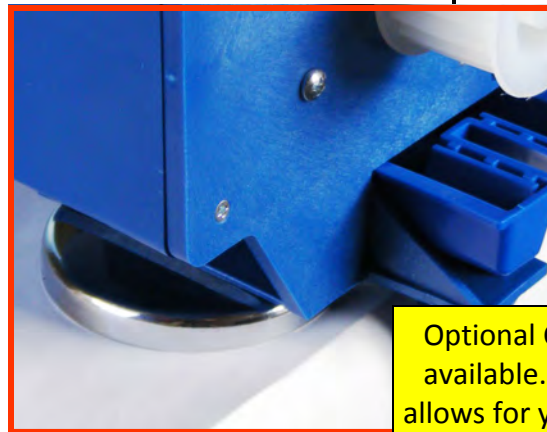
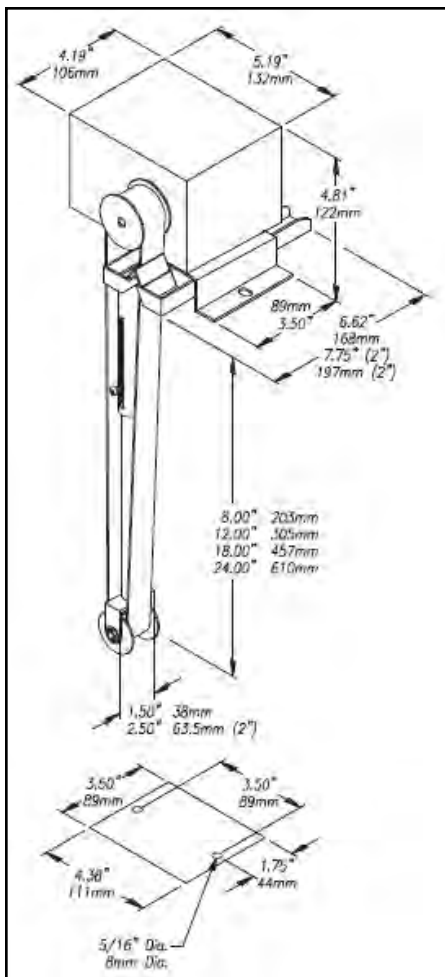
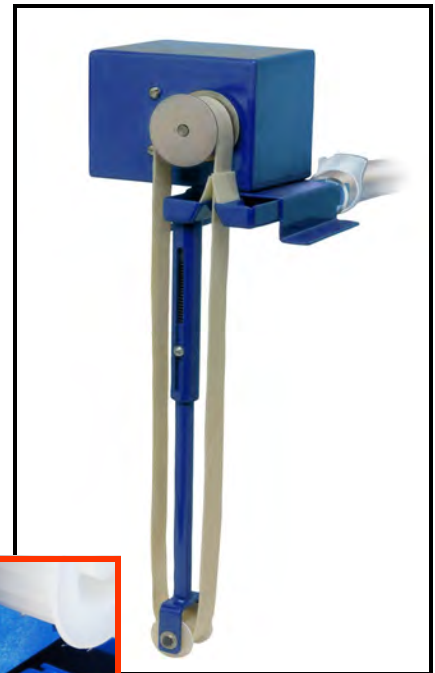

Optional **Cling-On Technology** available. Magnetic mounting allows for your skimmer to install with ease, anywhere in your shop!

MODEL	BELT WIDTH	BELT LENGTH
SLB-08	1"	8"
SLB-12	1"	12"
SLB-18	1"	18"
SLB-24	1"	24"

Cool Disk Skimmer

The inexpensive way to remove unwanted tramp oils from CNC coolants and parts washers, but with all the quality that you expect from Abanaki!

- Durable engineered polymer housing won't corrode
- Capped troughs prevent oil drips
- Boomerang blades wipe more oil off disk

Shaft is sealed to prevent premature motor wear from oil contamination
Disk type tramp oil skimmer with 1/2" x 12" disk and 110v fan cooled gear motor. Disk skimmer is constructed entirely of plastic and features plastic motor housing and frame.

MODEL	DISC DIAMETER
SCD-12	12"



TubeTastic!™ Tube Oil Skimmer

The Abanaki TubeTastic! oil skimmer can be used on machining centers with little or no access to the CNC coolant sump from above. This unit can skim oil from chip conveyors or even totally enclosed machining centers!

- Fan-cooled continuous duty motor
- Oil pickup rate of up to 1 1/2 g.p.h.
- Works in places where other skimmers can't

Standard tube lengths in reach: 8", 12", 18" and 24".
Longer lengths available.

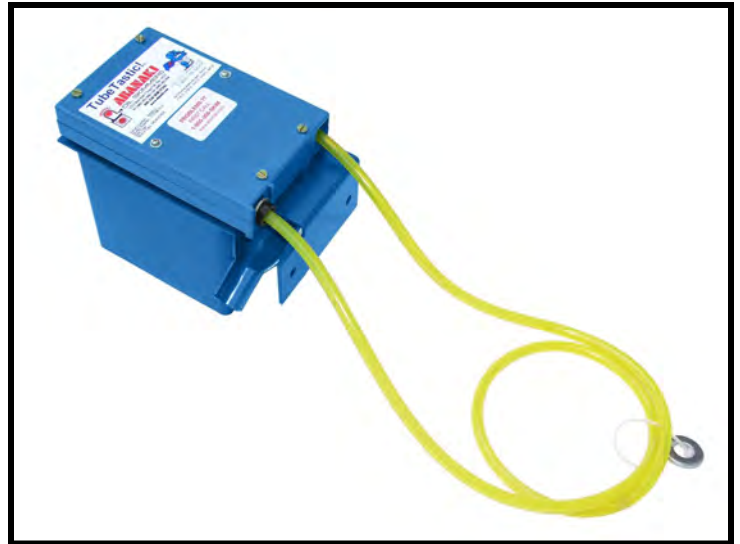

MODEL	TUBE WIDTH	TUBE LENGTH
STUBE1-08	3/8"	8"
STUBE1-12	3/8"	12"
STUBE1-18	3/8"	18"
STUBE1--24	3/8"	24"

EconoMini™ Coolant Skimmer

The EconoMini belt oil skimmer is an ultra-compact belt oil skimmer designed for use in coolant sump and parts washer applications. The skimmer can fit in tight spaces where other skimmers can't.

Standard Features:

- Long lasting, quiet 110v 1ph 60 Hz motor
- Polyurethane and stainless steel belts available
- Tethered tail pulley
- 8, 12, 18, and 24" lengths available
- Tiny Footprint; requires little mounting space
- No assembly required

MODEL	BELT LENGTH
SEM-08	8"
SEM-12	12"
SEM-18	18"
SEM-24	24"

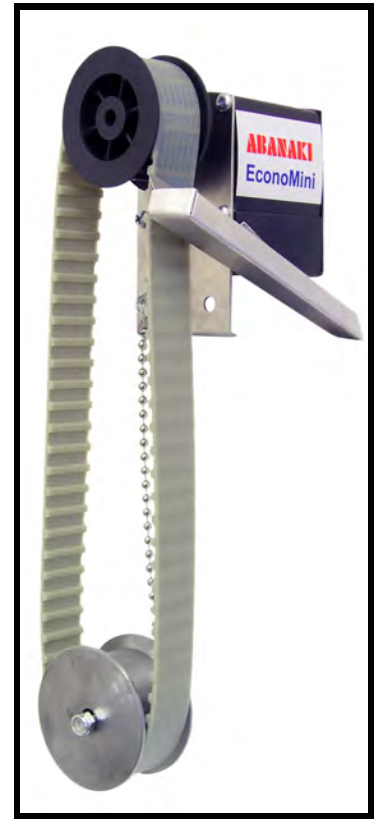
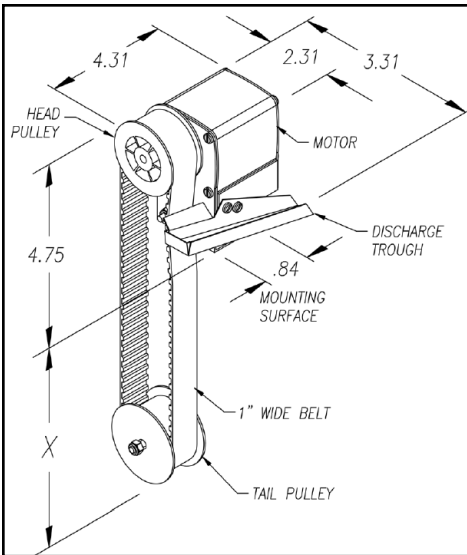

Coolant Mints™

Put an end to that nasty rotten egg smell.

- Safe to handle and easy to use
- Eliminates coolant odors immediately by neutralizing hydrogen sulfide gases
 - Not a perfume
 - No disposal problems
 - Contains no formaldehyde
- Safer and less expensive than biocides
- 1 tablet per week maintains 25 gallons of coolant
 - 15 tablets per tube



MODEL	TABLETS
CMINTS	15

Cooler™ Coolant Refresher

The Abanaki Cooler is a must for any machine shop dealing with machine tool coolant. This unit will extend CNC coolant life, reduce disposal costs, eliminate down time, improve tool life and help prevent dermatitis.

- Leak proof fittings
- Crush resistant hose
- One year warranty
- Self contained system
- Coalescing cartridge never needs to be replaced

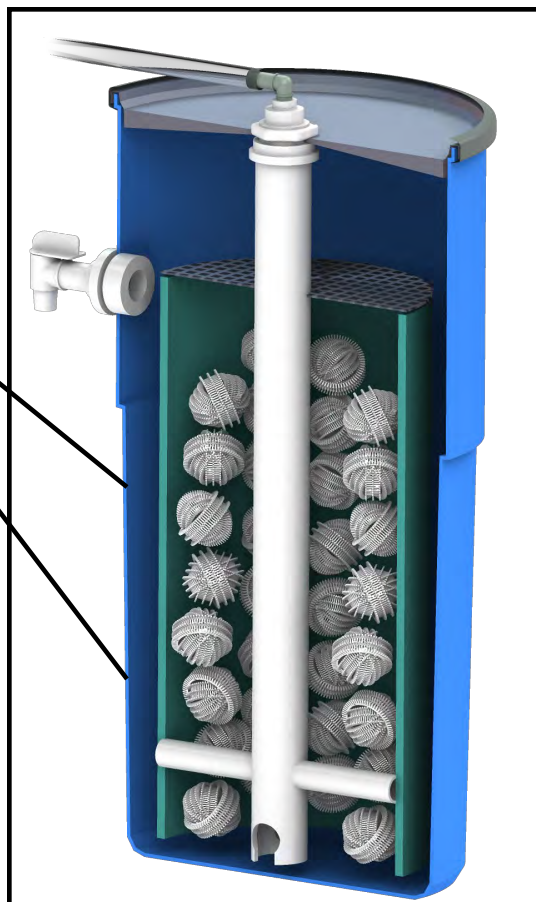

MODEL

CLR-B

Technical Information

Barrel Dimensions:	16" Dia. X 30" High
Capacity:	15 Gallons
Pump:	1 gallon per minute
Power:	110v, 60Hz

Cooler with ChipStop Filter

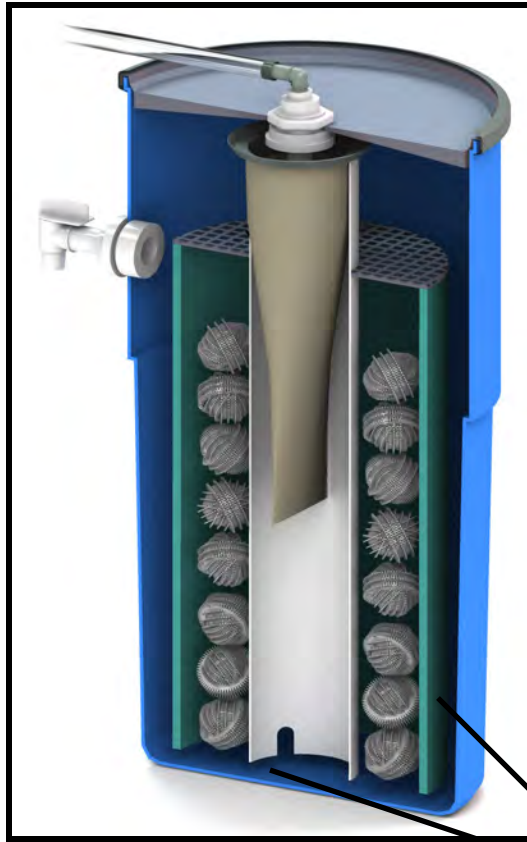

MODEL

CLRF-B

With the ChipStop Filter, all metal shavings or particulate that are generated in the machining process will get collected during the filtration process, leaving the shop with clean, reusable coolant.

- Leak proof fittings
- Crush resistant hose
- One year warranty
- Self contained system
- ChipStop Filter collects particulate
- Coalescing cartridge never needs to be replaced

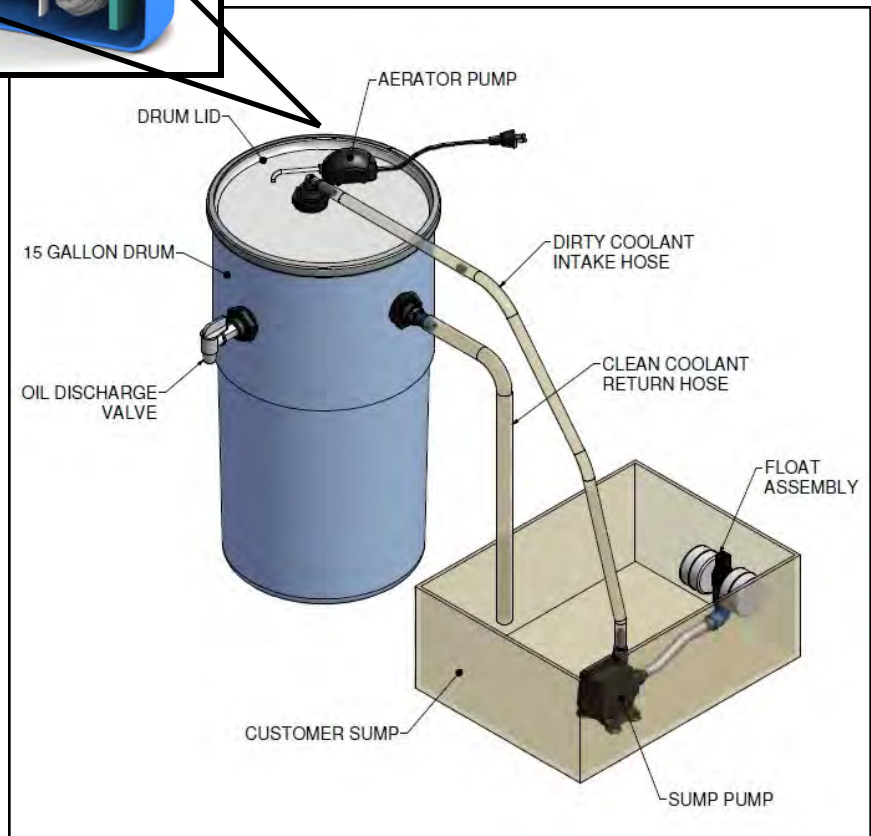

Q-VAC™ 100

Empties coolant from sump

- Vacuums oil, coolant, and other floor spills
- Removes surface decontaminates from process baths
- Empties tanks and drain pits
- Vacuums containers and vats absolutely dry
- Minimizes use of absorption materials
- Fits on a standard 55 gallon, open top drum
- Requires no filters
- Contains no parts to break or replace



MODEL	DESCRIPTION
QVAC1	55 GAL DRUM AIR VACUUM
QVACOT	55GAL DRM FOR OPEN TOP LIQUID AIR VAC
QVACDLX	AIR VAC W/DRUM CART COMPLETE DRUM AIR VAC SYS
QVACX	55 GAL DRUM/HAZ LIQUID EXP PRF AIR VAC

Chiperator™

Chip and Coolant Separation System. The air driven Chiperator vacuums and filters old cutting fluids loaded with chips from machine sumps, tanks and parts washers. When the optional Abanaki's Lil' Blue™ skimmer is purchased, the coolant will also be cleansed of tramp oils.

Save money by making old coolant useable again. The Chiperator is an inexpensive way to clean dirty machine sumps. The air driven Chiperator quickly separates chips and swarf from liquids. It drains or refills its 55 gallon drum in less than 2 minutes! Simply suck up coolant laden with chips, swarf and muck, and the Chiperator strains the unwanted solids. The Chiperator then pumps the strained coolant back to the sump.

Standard Features:

- Strains 40 gallons of chips and coolant per minute
- Efficient venturi design consumes less air than competitive models
- Acts as both a vacuum and a pump
- Economical, disposable filter bags make cleanup a breeze
- Filters out chips and shavings from plastic, steel, aluminum, ceramic, etc.
- Quiet; less noise than other air driven or electrical units
- No moving parts
- Equipped with float valve to automatically shut off unit when drum is full
- Equipped with automatic pressure relief valve for added safety
- Complete with on/off valve for easy shutoff



MODEL	FEATURES
CHIP	No Drum
CHIPD	Drum Included

EconoMixer™

EconoMixer 100 Coolant Proportioning Mixer and Dispenser drum or wall mounted proportioners automatically mix liquid coolant concentrates with water and dispense the diluted solution into any sump or container.

The **EconoMixer 200** is designed for speed, accuracy, and cost savings. Simply insert the unit into a 15 – 55 gallon drum of coolant concentrate and connect a water line to the unit.

- Increased productivity of employees
- Efficient use of space
- Enhanced safety
- Maximized cleaning product performance
- More conscientious response to environmental concerns.



EconoMixer 100



EconoMixer 200

MODEL
EMIX100
EMIX200

Abanaki Aerators

- Prevents anaerobic bacteria from building up and spreading
- Extends coolant life
- Eliminates the "rotten egg" smell
- Quality airstone diffuser disperses air evenly
- 2 units available:
 - ◇ AA1200 injects 1200 cc/min air for small sumps
 - ◇ AA5000 injects 5000 cc/min injects for large sumps



ChillyBits™

The ChillyBits air chiller uses compressed air to produce cold air to directly cool bits and tooling during machining operations.

- Eliminates mist cooling
- Uses no Freon
- Magnetic base for easy mounting
- Extends tool life
- Adjustable tip for precision tooling

MODEL	CFM (CUBIC FEET/MINUTE)
CB1	15 CFM
CB3	8 CFM

pH Meters

The **Abanaki pH Meter** is an effective way to easily measure the pH level of coolant from a range of 0 - 14.

Standard Features:

- 0-14 pH range, operating temperatures: 5° C to 50° C
 - ATC: automatic temperature compensation for accuracy!
- Power supply: DC4 X 1.5V (button battery)
 - 1-year warranty against defects



Model
pH-A

ChillyBox Panel Chiller

The Abanaki ChillyBox Panel Chiller is designed to cool NEMA 4 & NEMA 12 industrial cabinets using filtered compressed air. The ChillyBox helps maintain temperature and air quality within the enclosure, helping to reduce loss of production time that typically occurs when control panels overheat.

Abanaki's ChillyBox kit works with your existing control panel box.

Kit Includes:

- ChillyBox Panel Chiller
- Solenoid
- Air filter
- Barbed fitting nut
- Barbed hose fitting
- Thermostat
- Air tubing
- Air tubing plug

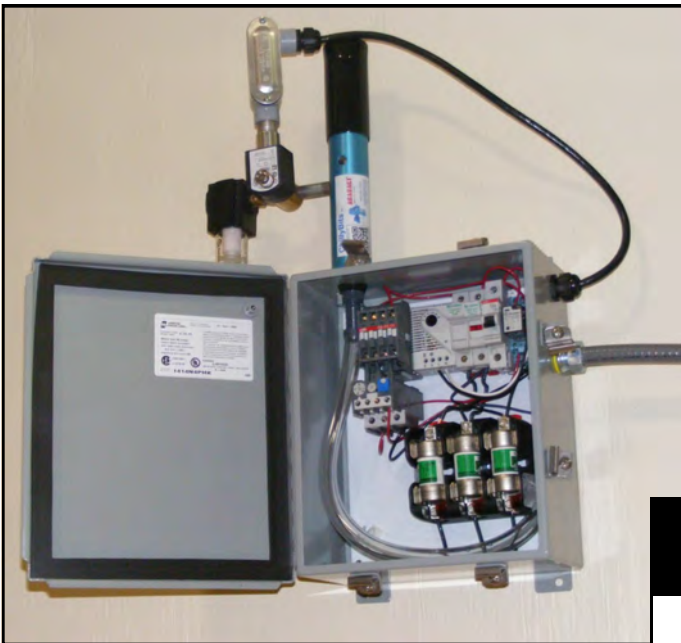
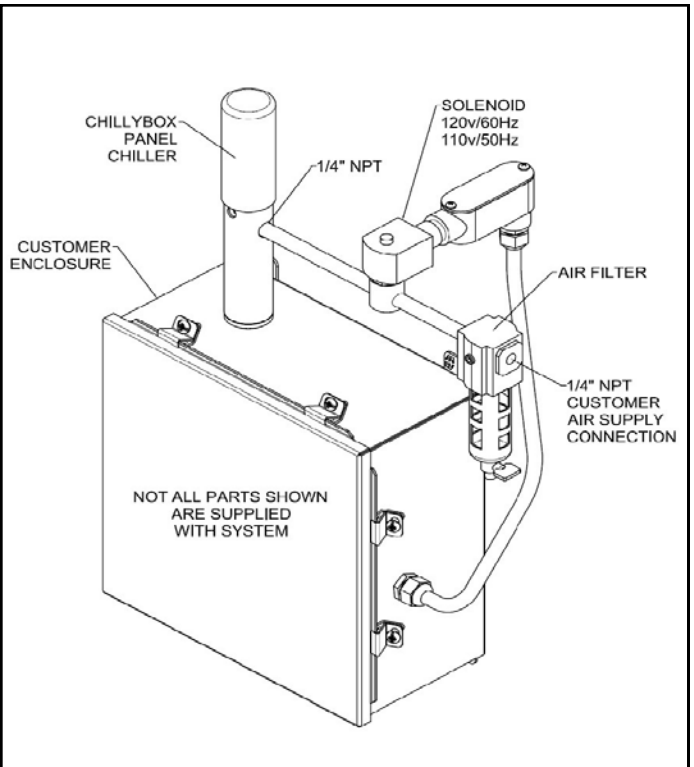

Model	BTU (British Thermal Unit)
CX4	400
CX9	900

Oil Concentrator® - Oil Water Separator

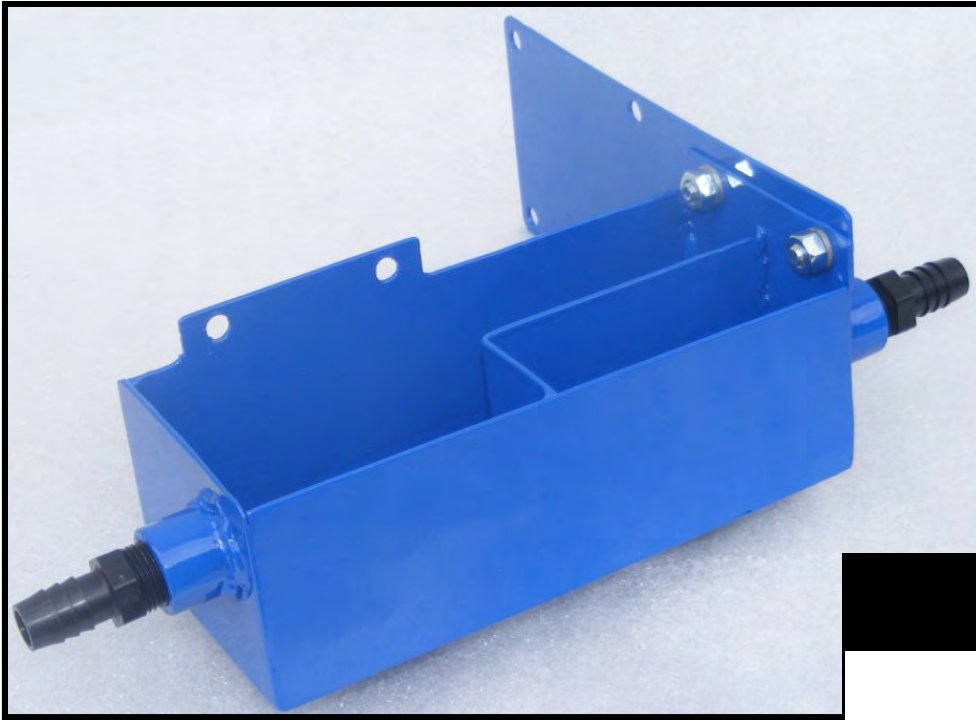

Model

ODM50

The Abanaki Oil Concentrator performs as a virtually complete oil water separator for recycling or disposal of either liquid.

Under most operating conditions, Abanaki skimmers pick up oil with only small traces of water. However, as surface oil is reduced to a thin layer (1/16 inch thick or less), more water (or coolant) may be picked up along with the oil. When used in tandem with an oil skimmer, the Oil Concentrator solves this problem by providing final phase separation. The result is water (or coolant) available for recycling, and virtually water-free oil for disposal.

Installed at the discharge end of the oil skimmer, the Concentrator comes complete with mounting bracket, removable sludge screen and drain plug for easy cleaning.

Features

- Mounts easily on Abanaki skimmers
- Brackets and hardware supplied by Abanaki
- Corrosion resistant finish
- Sludge screen keeps large debris out of skimmed oil
- Drain plug facilitates routine maintenance

Refractometers

Cut coolant maintenance costs with Abanaki's new line of handheld refractometers and pH meters.

- Refractometer use improves machine shop productivity and reduces coolant maintenance costs by allowing operators to measure coolant quality quickly and easily.
- Maintaining proper coolant concentration is critical to reducing tooling costs and manufacturing high quality parts with ideal surface finishes.
- Regular monitoring can ensure that expensive concentrate is not wasted and weak coolant is boosted or replaced for maximum performance.

Coolant potency diminishes over time and, if not properly maintained, the consequences can be costly.

Standard Features:

Abanaki refractometers are available in three models, including two with a built-in light.

R1-A Refractometer:

- Portable 0 - 32% Brix scale with automatic temperature compensation (ATC)
- Internal light source that uses 1.5v button batteries
- Big print scale
- Aluminum construction

R1-B Refractometer:

- Portable 0 - 10% Brix scale with automatic temperature compensation (ATC)
- Internal light source that uses 1.5v button batteries
- Big print scale
- Aluminum construction

R2/R3 Refractometer:

- Portable 0 - 32% Brix scale with automatic temperature compensation (ATC)
- Accurate to 0.2% Brix
- Aluminum construction



Visit www.abanaki.com for more detailed product brochures, video tutorials, animated product demos, white papers, blogs, and other free resources to help you better solve your oil skimming problems.



Oil Skimming Fact Tutorial Handbook

The industry's most complete guidebook on how to select and size an oil skimmer for your application. This handbook contains information on all aspects of oil skimmer application .



Solutions Sourcebook

This 43-page handbook offers application notes on more than 40 real-world implementations of oil skimming. The Abanaki Solutions Sourcebook is indexed both by type of industry and by type of application, enabling readers to quickly find the case studies that are most relevant to their situation.

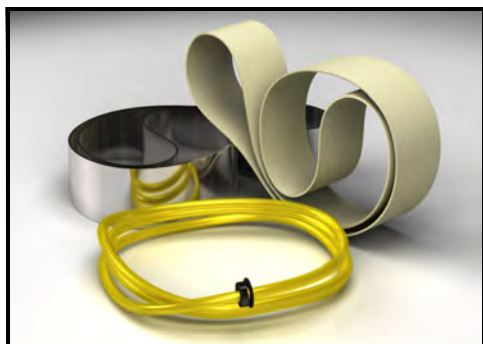

Skimming Material Test Kit

Kit includes belt and tube sample materials that you can use to test their effectiveness at your location. Will your oil pick up? We will send you sample materials which may include fuzzy, steel, poly, and elastomer belts, and/or collector tubes for standard and high temperature applications.

The

RECYCLE

REVIEW

Understanding *Coolant Recycling*

The Benefits of Recycling Your Coolant:

Cleaner Work Environment

less smoke, less oil
on floors and less
employee skin problems

Reduce
new coolant purchase by
50% to 75%



Increase
tool life by up to
33%



Source: Clearwater Technologies

Recycling Typically:

Reduces total
cost of fluid
management
by up to **85%**



Reduces
disposal
cost
by **95%**



ABANAKI®

OIL SKIMMERS

The world leader in oil skimming technologies for more than 40 years.



Skimmerman™

AHB

TOOLING & MACHINERY

Learn more about the cost-effective oil skimming solutions Abanaki offers by visiting www.abanaki.com. Our website offers a wide range of product info, video tutorials, detailed handbooks, and more. To speak to a representative call (800)991-4225.

COMPLETE
METALWORKING
SOLUTIONS

(800) 991-4225

www.ahbinc.com

ISO Certified

customerservice@ahbinc.com