

8 7 6 5 4 3 2 1

Leave adequate clearance to ceiling for filter changes

Access Door
Leave adequate clearance for filter change

Mist-Fit MF-1050

Pedestal

Hex Bolt 1/4"-20 (x8)
with 1/4" Sealing Washer

Pedestal Base 10.5" x 10.5"

CNC Machine Top
with obstructions
unsuitable for standard Base Plate

Hex Bolt 1/4"-20 (x8)

Cut a 8 inch diameter hole
in a suitable location
if no machine knock out is provided

Drill clearance holes for 1/4" bolts
use Pedestal as a template
and drill to suit

Sealing Washer 1/4" (x8)

Hex Nut 1/4"-20 (x8)

Apply a sealant
to mating surface
if required



COMPLETE METALWORKING SOLUTIONS
(800) 991-4225
ISO Certified
www.ahbinc.com
customerservice@ahbinc.com



Aeroex Technologies Inc.
17 Hamilton Road
Barrie, On L4N 8Y6
Tel. 705-734-0199

Title: Installation, MF-1050, Pedestal			
Dwg. No.	M10MBD-0015-C		Size B
Date: March 12, 2019	Drawn: T.B.	Do not scale drawing	Sheet 1 of 1

8 7 6 5 4 3 2 1

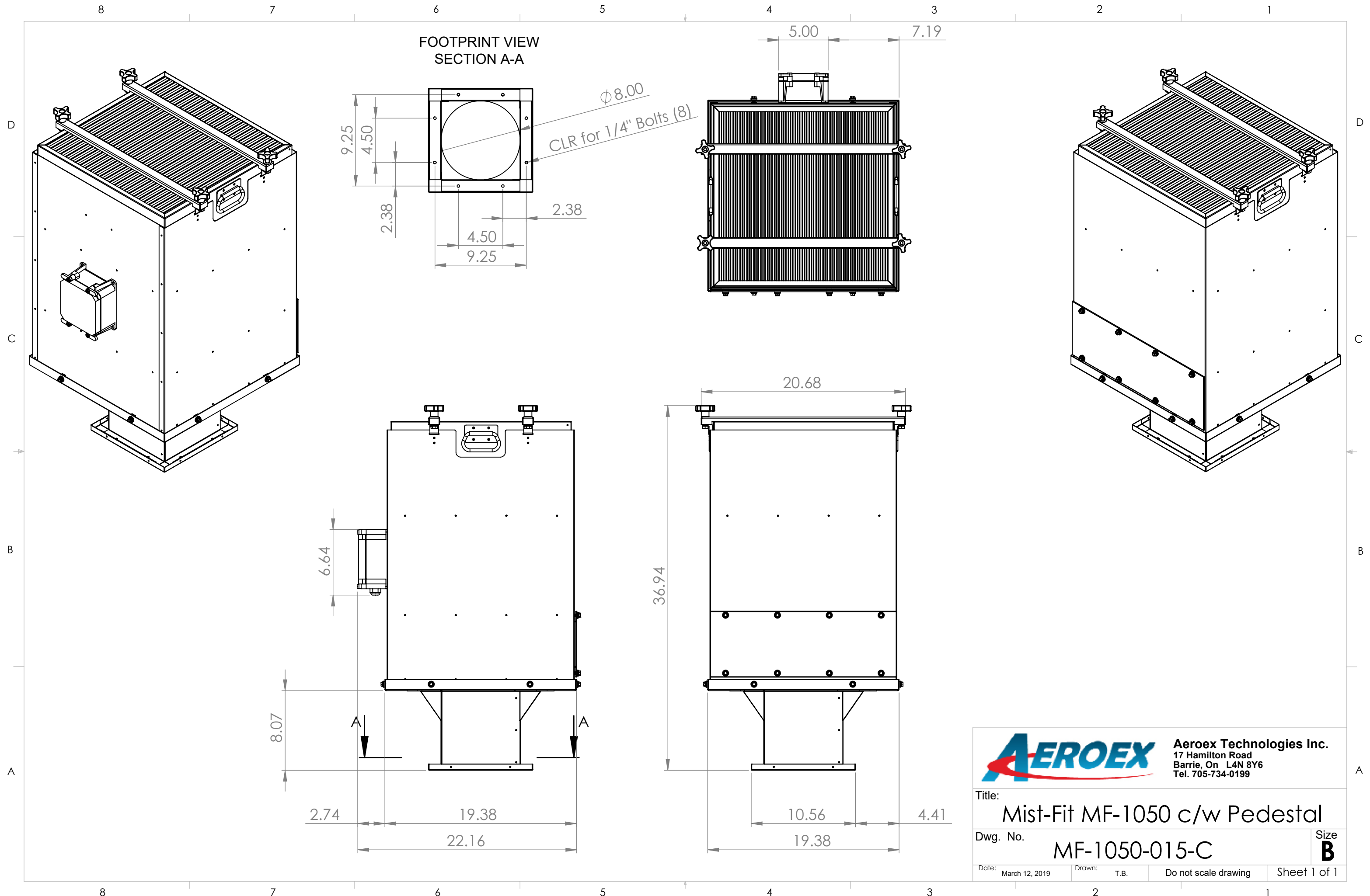

AEROEX Aeroex Technologies Inc.
 17 Hamilton Road
 Barrie, On L4N 8Y6
 Tel. 705-734-0199

Title: Mist-Fit MF-1050 c/w Pedestal

Dwg. No. MF-1050-015-C Size **B**

Date: March 12, 2019 Drawn: T.B. Do not scale drawing Sheet 1 of 1