

MODELS F33, F66, F73 R&L INDUSTRIAL ELECTRONIC AIR CLEANERS

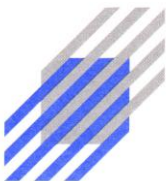

**AIR QUALITY
ENGINEERING**

7140 Northland Drive North, Brooklyn Park, MN 55428-1520 USA
FAX: (763) 531-9900 **EMAIL:** info@air-quality-eng.com **WEB SITE:** www.air-quality-eng.com
TOLL FREE: 1-800-328-0787

Air Quality Engineering Inc., has a policy of continuing product improvement and reserves the right to make changes in design and specification without notice.

Before you get started please review the following:

Purchase Date: _____

Serial Number: _____

Motor Spec: _____

Belt and Sheave Used: _____

Type of oil / coolant collected: _____

Type of filter and AQE P/N: _____

Customer Technical Support:

To contact Air Quality Engineering use:

Mail: Air Quality Engineering
7140 Northland Drive N.
Brooklyn Park, MN 55428
USA

Phone: 1.800.328.0787
763.531.9823

Fax: 763.531.9900

e-mail: info@air-quality-eng.com

web: www.air-quality-eng.com

Copyright

Air Quality Engineering, Inc. copyrights this manual with all rights reserved. Under the copyright laws, this manual may not be reproduced in any form, in whole or in part, without the prior written consent of Air Quality Engineering, Inc.

© 2008

Disclaimer

All statements, technical information and recommendations in this manual or related documents are believed reliable, but the accuracy and completeness thereof are not guaranteed or warranted, and they are not intended to be, nor should they be understood to be representation or warranties concerning the products described.

Specifications are subject to change without notice.

TABLE OF CONTENTS

	PAGE
SPECIFICATIONS	4
DIMENSIONS	5
PLANNING THE INSTALLATION	8
Introduction	8
Sizing	8
Ambient Cleaning	10
Source Capture Cleaning	10
INSTALLATION	14
When Installing This Product	14
Unpacking	14
Stand Mounting	14
Overhead Mounting	14
Source Capture Plenum	14
Electrical Installation	15
CHECKOUT AND OPERATION	16
Checkout	16
Operation	16
ADJUSTMENTS	16
SERVICE	17
When to Wash the Electronic Cells	17
Cleaning the Pre/Post Filters	17
The Alkaline Detergent Solution Cleaning Method	17
Replace the Electronic Cells and Pre/Post Filters	18
Ionizing Wire Replacement	18
TROUBLESHOOTING	18
ELECTRICAL SCHEMATICS	20
PARTS LIST	21
WARRANTY	25

HOW AIRBORNE CONTAMINATION IS REMOVED

A process called “Electrostatic Precipitation” traps airborne contaminants. The fan draws particulate laden air successively through the prefilter, the cell ionizing section and the cell collector section. The ionizing section imparts an electrical charge to the individual particles that are then drawn by electrostatic forces to the oppositely charged collector plates. Cleaned air is then discharged back into the room. The electronic cells must be washed periodically to maintain efficient performance.

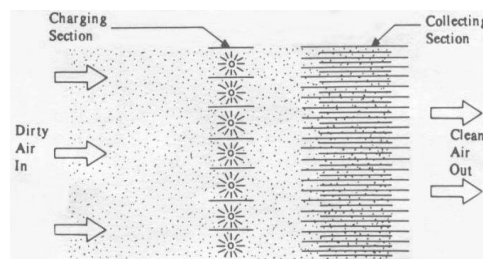

SPECIFICATIONS

- IMPORTANT -

THE SPECIFICATIONS GIVEN IN THIS PUBLICATION DO NOT INCLUDE NORMAL MANUFACTURING TOLERANCES. THEREFORE, THIS UNIT MAY NOT MATCH THE LISTED SPECIFICATIONS EXACTLY. ALSO, THIS PRODUCT IS TESTED AND CALIBRATED UNDER CLOSELY CONTROLLED CONDITIONS AND SOME MINOR DIFFERENCES IN PERFORMANCE CAN BE EXPECTED IF THOSE CONDITIONS ARE CHANGED.

SPECIFICATIONS

- Cabinet: 16 gauge welded steel cabinet with a powder coat finish.
- Airflow: Models are available with airflow from left to right or right to left.
- Instrumentation: Indicator Light – Light indicates that the collector cells are energized properly. Test button diagnostics give status of collector section
- Power Supply: Solid state, self- regulating power supply out-put is not affected by moderate fluctuations in line voltage.
- Electrical: Units are powered from standard grounded outlet. All single phase models equipped with a 10-foot power cord. Three phase have pig tail only.
- Electrical Safety: Interlock switches prevent operation when cell access doors are open
- Motors: Heavy-duty, permanently lubricated, ball-bearing motor requires no maintenance.
- Ambient Temperature Rating: Airflow through cells: 125°F [52°C] max., 40°F [5°C] min.
- Filters:

F33:	1x41075 24-1/8"x13-3/8"x1"	F66:	1x41052 25-1/2"x24-1/4"x1"	F73:	2x41113 24"x24"x1"
Prefilter:	1x41075 24-1/8"x13-3/8"x1"	Main:	2x38003 24"x12"x10-1/2"	Main:	2x38010 24"x23-3/4"x10-1/2"
Post:	1x41075 24-1/8"x13-3/8"x1"	Post:	1x41052 25-1/2"x24-1/4"x1"	Post:	2x41113 24"x24"x1"
- Outlet: Adjustable discharge grill directs airflow where needed.
- Optional: Plenum and hoses make source capture applications easy.

Air Quality Engineering, Inc., has a policy of continuing product improvement and reserves the right to make changes in design and specifications without notice.

Vac, Hz, Ph	Amps				
	1 Hp	1.5 Hp	2 Hp	3 Hp	5 Hp
120, 60, 1	12.6	17.2	18.8	NA	NA
208-240, 60, 1	6.3	8.6	9.4	NA	NA
208-240, 60, 3 Direct Drive	3.6	NA	6.2 6.0	8.6 8.2	12.8 13.2
440-480, 60, 3 Direct Drive	1.8	NA	3.1 3.0	4.3 4.1	6.4 6.6

* Note: 50hz models, 575V and other electrical requirements available upon request.

DIMENSIONS

F33 R&L

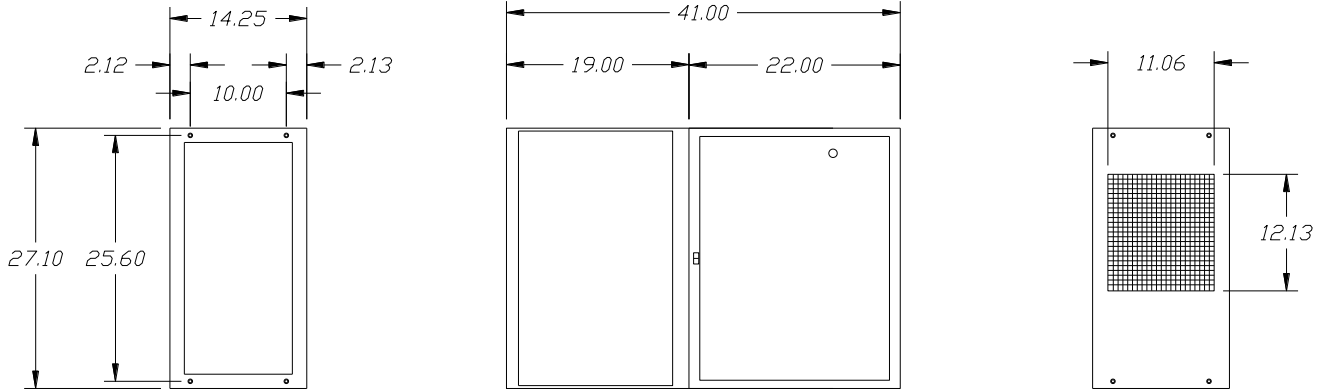

F33 190 lbs installed weight, 230 lbs shipping weight
F33 Filter Door Clearance: 18"

Optional Inlet/Outlet Plenum: 18"L x 27.1"H x 14.25" D
Optional Source Capture Arms available

F66 R&L BELT DRIVE

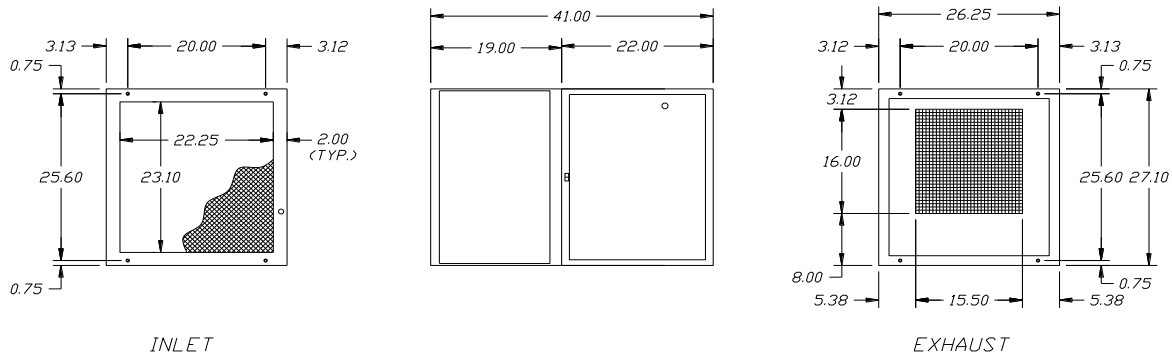

F66 R&L DIRECT DRIVE

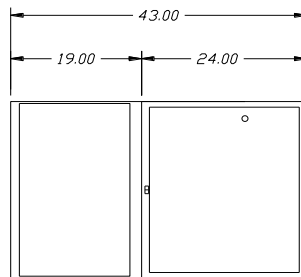

F66: 280 lbs installed weight, 325 lbs shipping weight

F66 Filter Door Clearance: 18"

Optional Inlet/Outlet Plenum: Adds 19" to length and 43 lbs. to weight

Optional Wrap-around Pre-filter section: Adds 20" to length and 50 lbs to weight, front access for filter replacement

Optional additional Prefilter section (4" prefilter): Adds 7" to length and 33 lbs. to weight

Prefilter door clearance: 6"

Optional additional Impinger section (4" impingers): Adds 7" to length and 55 lbs. to weight
Impinger door clearance: 6"

Optional additional Carbon module: Adds 14" to length and 150 lbs. to weight

Carbon module door clearance: 11"

Optional additional HEPA module: Adds 17" to length and 125 lbs. to weight

HEPA module door clearance: 15"

Optional Silencer: Adds 12" to length and x 60 lbs. to weight

Optional Source Capture Arms available

F73 R&L

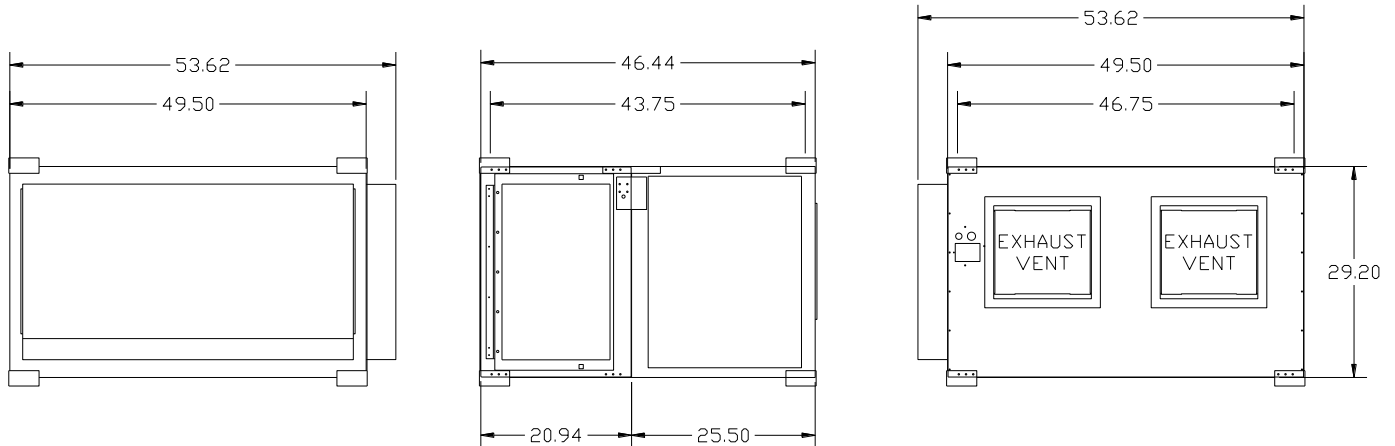

F73: 495 lbs installed weight, 550 lbs shipping weight

F73 Filter Door Clearance: 18"

Optional Inlet/Outlet Plenum: Adds 17" to length and 52 lbs. to weight

Optional Wrap-around Pre-filter section: Adds 20" to length and 100 lbs. to weight

Wrap around Pre-filter front access for filter replacement

Optional additional Impinger section (4" impingers): Adds 7" to length and 105 lbs. to weight

Impinger door clearance: 6"

Optional Carbon module: Adds 33" to length and 450 lbs. to weight

Carbon module door clearance: 27"

Optional Source Capture Arms available

PLANNING THE INSTALLATION

- WARNING -

Air Quality Engineering, Inc. air cleaners are not explosion-proof. They must not be installed where there is danger of vapor, gas or dust explosion.

INTRODUCTION

Clean air is the subject of numerous laws and regulations. Typical requirements in the United States are those put out by the Occupational Safety and Health Administration (OSHA). Private groups, such as the American Society of Heating, Refrigeration and Air Conditioning Engineers (ASHRAE), have also published numerous recommendations.

Normally, clean air is defined in regulations and recommendations as air having a limited amount of contaminant in it, commonly expressed as parts per million or milligrams per cubic meter. Approved counteractions are intended to lower or eliminate the amount of contaminants in the air. One of the more common methods of achieving this goal is through the use of electronic air cleaners.

At no time should an electronic air cleaner be placed where there is a potential for explosion due to the presence of explosive dusts, gases or vapors. Contact the nearest Air Quality Engineering, Inc., representative for assistance in determining the correct application of a media air cleaner.

SIZING

Sizing is that part of the installation which determines how many air cleaning units are required to maintain a desired level of air quality. The process of sizing an application involves roughly calculating the number of air cleaners needed and then modifying the calculation according to the specific characteristics of each application.

If air contaminants are generated from fixed stations where hoods and hoses can be acceptably installed, cleaning the air by capturing the contaminant at the source is strongly recommended. For source capture air cleaning, a hood (not provided) is installed where the contaminants are generated and an attached hose

feeds the contaminants to a source capture plenum. The plenum transfers the contaminants directly into the air cleaner (hose and plenum are ordered as accessories).

The actual number of contaminant sources that can be ducted into one air cleaner may vary depending on the nature of the contaminants. The composition, quantity and rate of generation of the contaminants determines the air velocity needed to effectively capture these contaminants at the source. The required air velocity, in turn, not only affects the hood design and location but it also sets limits on how much hose can be used before the air pressure drop becomes too great for effective contaminant capture.

Therefore, when sizing an application for source capture air cleaning, it is necessary to keep in mind how the specific contaminants, the hood and the needed velocity all combine to affect the number of stations which can be attached to a single unit and the number of units which will be needed for a particular application.

When the installation of hoods and hoses is physically infeasible or unacceptable, the air cleaners are strategically placed overhead or on stands to provide background air cleaning.

For background air cleaning, the number of electronic air cleaners needed can be estimated by the relationship of air volume to the needed air changes per hour. In these cases, the following formula is helpful:

$$\text{Air Cleaners} = \frac{\text{Air Volume} \times \text{Air Changes/Hour}}{\text{Clean Air Rating}}$$

Or reference our website:
<http://www.air-quality-eng.com/sizing.php>

The air volume in a space is sometimes reduced to account for high ceilings and large equipment in the space. For example, in an application where the ceiling is higher than 30 ft. (9.1 m), the air volume above 30 ft. (9.1 m) may be subtracted if it does not significantly affect contaminant dispersal either by how the contaminants are circulated from their sources or how the heating, cooling or ventilating equipment affects the disbursement of the contaminants. Also, if equipment takes up a great deal of space in relation to the total air

space, its' volume may be deducted from the total air volume.

A method for calculating the needed air changes per hour is to measure the generation rate of the contaminants and the suggested allowable level of contamination. To use this method of calculation, consult your Air Quality Engineering, Inc., representative.

Regardless of the method used to calculate the number of units needed to produce clean air, the physical conditions of the space to be cleaned may either limit this number or demand that more units be installed. For background air cleaning, it is important to establish a uniform airflow pattern

throughout the entire space. Limitations to the calculated sizing may be a lack of space for mounting areas or the number of units may interrupt normal building operation; that is, a unit cannot be mounted where an overhead crane will smash into it or where stand mountings seriously interrupt building traffic patterns. The number of units required by air volume and air changes per hour might need to be increased when the shape of a structure is such that effective capturing and air distribution is not possible according to the sizing calculations.

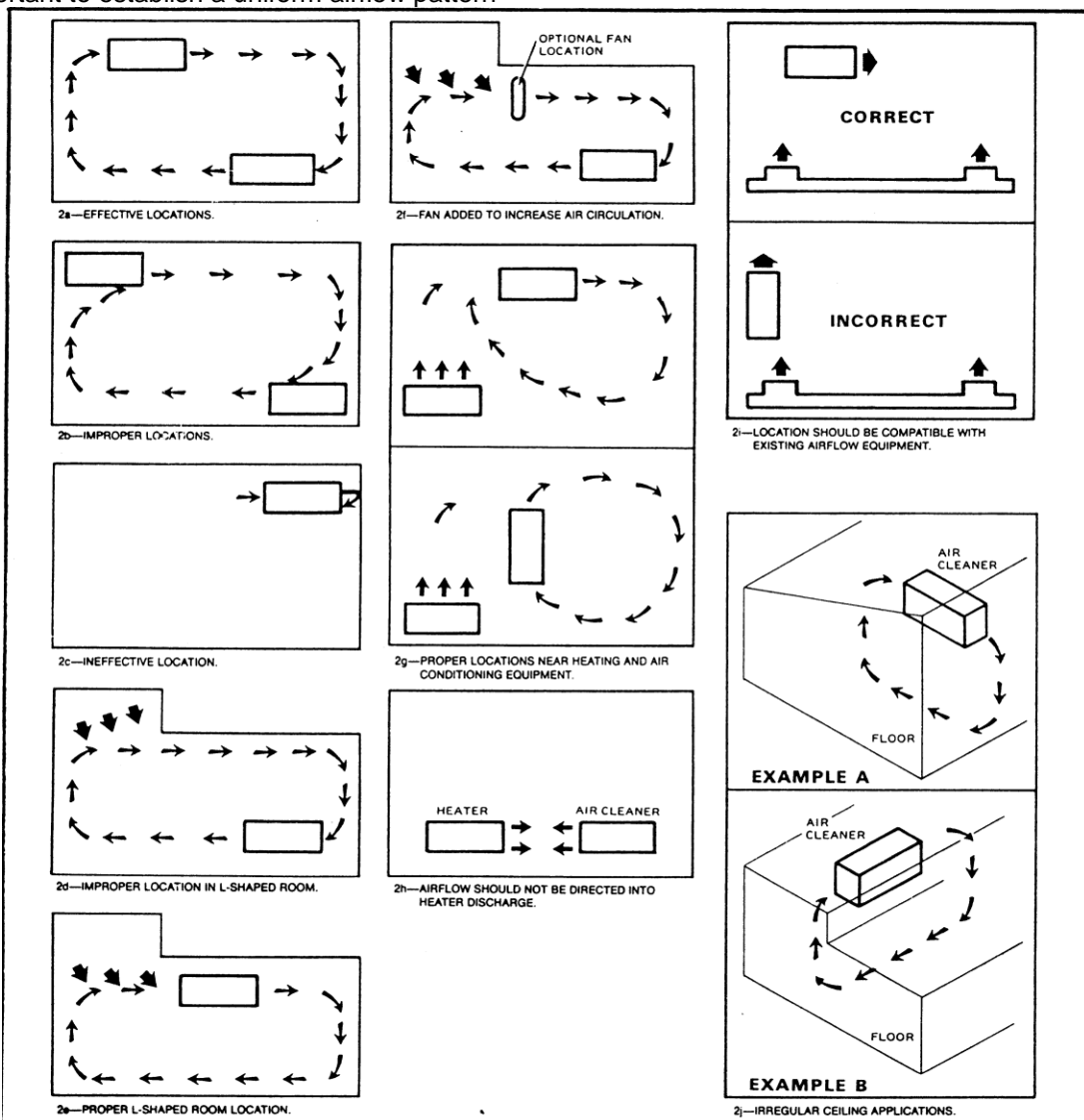

FIGURE 2 – GUIDELINES FOR LOCATING THE AIR CLEANER WHEN AMBIENT CLEANING

AMBIENT CLEANING

Whether an air cleaner is ceiling hung or placed on a stand, the first important consideration is that the inlet of the unit be located as close as is reasonably possible to the greatest concentration of air contaminants. Second, since the air cleaner draws contaminated air from approximately 10 ft. (3.0 m) around the outlet and exhausts the cleaned air from 50 to 75 ft. (15.2 m to 22.8 m) from the outlet, the inlet of the unit should be placed 25 percent of the distance along the wall of a room. See Fig. 3.

DO NOT locate an air cleaner inlet too close to the corners of a room. Contaminated air will be able to bypass the unit and not be cleaned. DO NOT locate an air cleaner outlet too close to a corner or wall. See Fig. 2 (2c). The cleaned air will recirculate directly back to the air cleaner inlet.

DO NOT locate an air cleaner in an L-shaped room so that exhausted air enters directly into the small portion of the room as shown in Fig. 2 (2d). This can produce a self-contained circular air pattern in the small part of the room that decreases the air cleaner's effectiveness. Locate an air cleaner in an L-shaped room as indicated in Fig. 2 (2e).

The shape of a room and location restrictions may require the installation of a fan as in Fig. 2 (2f) to promote proper air circulation. Also, the size of a room may require the use of fans to bring contaminants to an air cleaner inlet.

In rooms with irregular ceilings, install the air cleaner close to the ceiling on the highest wall as Example A indicates in Fig. 2 (2j). When one section of the ceiling is at least 12 in. (3-4.8 mm) higher than another, locate the air cleaner in the area with the higher ceiling as shown in Example B of Fig. 2 (2j).

When selecting locations for numerous units, position the air cleaners to create uniform movement of air and provide maximum access to the sources of contamination. The outlets of the air cleaners should not be located so that they generate opposing air currents or that the outlet from one air cleaner is less than 30 ft. (9.1 m) from the inlet of another air cleaner.

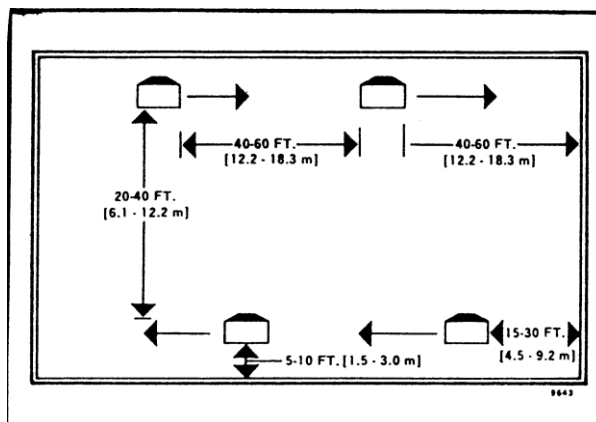

FIGURE 3 – LOCATION GUIDE FOR BACKGROUND CLEANING

SOURCE CAPTURE CLEANING

When selecting a location for an electronic air cleaner that uses a hood and hose to capture the contaminants at the source, note the available stand or ceiling mounting areas that will provide satisfactory air distribution for the air cleaner outlet. Choose the location that will keep the air pressure drop caused by the length of the hose within an acceptable range. Do not mount the outlet of the air cleaner so close to a wall that it inhibits the airflow. Also, the outlet of an air cleaner should not be located such that it interferes with the source capture process of another air cleaner hood.

To effectively control atmospheric contamination at its source, proper hood design is necessary. Minimum airflow and power consumption are also important factors in designing an effective local exhaust system to control contamination.

Capturing air contaminants at their source requires the creation of sufficient airflow past the contaminant source to remove the contaminated air and draw it into an exhaust hood. Fine airborne dust particles, mist, vapors, gases and fumes follow air currents. Airflow alone is sufficient to capture these contaminants.

Larger dust particles tend to have a trajectory, or throw, in air. Capturing these heavier particles calls for barriers and proper hood placement to direct the particles into the hood before they fall out of the air stream. This placement should also prevent particle scattering.

Basic knowledge of the contaminated airflow to be controlled is necessary before an effective hood or

enclosure can be designed. The more complete and effective the design, the more economical and efficient the installation will be.

A complete enclosure is often the best way to start. Once a source is ideally enclosed, provide access and working openings as required. This concept can be used to develop booths, side- or downdraft hoods and side shields.

The access and working openings must be kept to a minimum. Whenever possible, they must also be kept away from the contaminated airflow. Any inspection and maintenance openings should be provided with tight doors whenever possible.

A hood that is open and does not enclose or confine the contaminant should be avoided. Open hoods can be used but exhaust volumes must be large and cross drafts nearby can easily upset draft control.

Canopy hoods are effective in controlling operations that may suddenly release surges of gases and vapors. Hot processes are an example.

However, canopies should not be used where people may be working in the airflow between contaminant source and canopy because exhaust airflow can actually increase the worker's exposure to the contaminant. Plating tanks and cementing tables typically have this problem with canopy-type hoods.

The duct takeoff in the exhaust hood should be located in the normal line of contaminant travel. Arrange the duct openings to distribute the exhaust airflow throughout the hood. This is especially important with large, shallow hoods where air movement tends to concentrate close to the duct opening. The airflow can be spread around the hood by using multiple duct takeoffs, interior baffles or filter banks.

Air intake from areas not needing airflow or without contaminants can be controlled with flanges. Flanges minimize airflow from areas outside the desired air collection area. Usually the flange width is equal to the hood diameter but not exceeding 6 inches (152.4 mm). Flanges may increase the effectiveness of the hood allowing a reduction in hood airflow requirements by up to 25 percent.

Exhaust airflow requirements are calculated after the hood design is determined. The airflow volume is calculated using the enclosure's known open area and the airflow velocity needed to collect the contaminants. The collected airflow must be sufficient to prevent the escape of any contaminated air. Table 1 shows airflow capture velocities for various type of processes.

Where enclosing the process is impractical, the hood should be located as close to the source as possible. The airflow must be adequate to maintain the capture velocity required to carry the contaminants to the hood opening. See Fig. 4.

TABLE 1 – CONTAMINANT CAPTURE VELOCITIES^a

CONTAMINANT DISPERSAL CONDITION	EXAMPLES	CAPTURE VELOCITY	
		fpm	m ³ /hr.
Released with practically no velocity into quiet air.	Evaporation from tanks, degreasing, etc.	50-100	914-1829
Released at low velocity into moderately still air.	Spray booths, intermittent container filling, low speed conveyor transfers, welding, plating, pickling.	100-200	1829-3658
Active generation into zone of rapid air motion.	Spray painting in shallow booths, barrel filling, conveyor loading, crushers.	200-500	3658-9144
Released at high initial velocity into zone of very rapid air motion.	Grinding, abrasive blasting, tumbling.	500-2000	9144-36,576

In each category above, a range of capture velocity is shown. The proper choice of values depends on several factors.

Lower End of Range

1. Room air currents minimal or favorable to capture.
2. Contaminants of low toxicity or of nuisance value only.
3. Large hood-large air mass in motion.

Upper End of Range

1. Disturbing room air currents.
2. Contaminants of high toxicity.
3. High production, heavy use.
4. Small hood-local control only

^aFrom INDUSTRIAL VENTILATION MANUAL by American Conference of Governmental Industrial Hygienists.

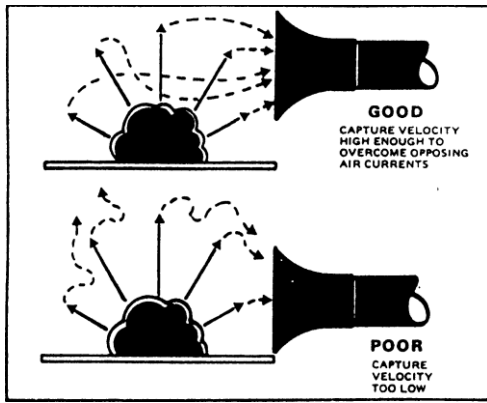

FIGURE 4 – CAPTURE VELOCITY

Collecting contaminants is accomplished by eliminating or minimizing natural air currents at the contaminant site and by pulling the air into the exhaust hood. The airflow velocity must be high enough to overcome any opposing air currents and maintain the capture velocity. See Fig. 4.

Source of air motion to either minimize or use to advantage in hood design:

- Thermal air currents from heat generating operations.
- Machinery motion (conveyor belts, grinders, etc.).
- Material motion (dumping or container filling).
- Operator movements.
- Room air currents (generally 50 fpm [85 m³/hr.] minimum, could be much higher).
- Spot heating, cooling or ventilation equipment near area.

See Fig. 5.

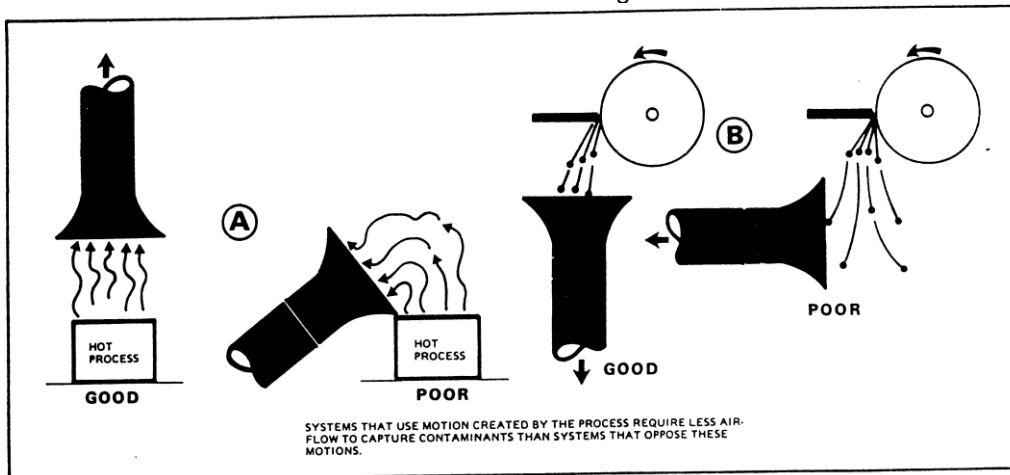

FIGURE 5 – UTILIZING PROCESS MOTION

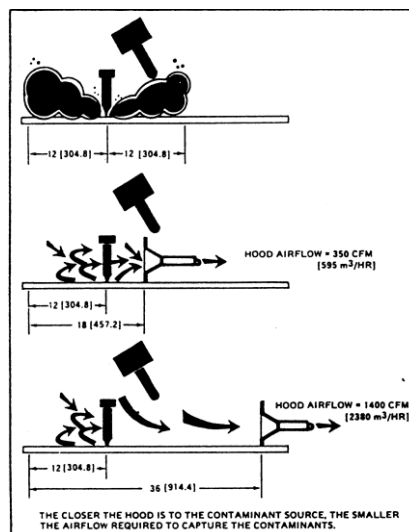

FIGURE 6 – HOOD LOCATION, AIRFLOW NEEDED INCREASES WITH DISTANCE FROM WORK

The airflow needed in a hood design is affected by hood shape, size and location. The hood should be as close as possible and enclose the operation as much as possible.

Suction in a duct opening will draw in air equally from all directions. As distance from the inlet opening increases, the decrease in airflow velocity occurs more quickly. The velocity in feet per minute (fpm) equals the cubic feet per minute (cfm) from Fig. 10 divided by inlet area in feet (0.35 for 8-inch hose).

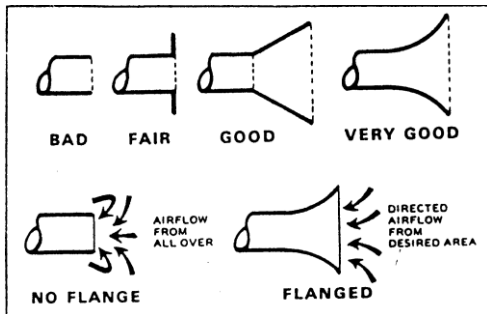

FIGURE 7 – HOOD FLANGES

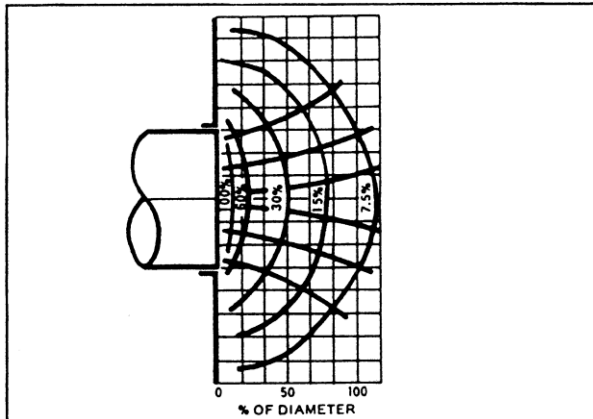

FIGURE 8 – VELOCITY CONTOUR (IN PERCENTAGE OF OPENING VELOCITY) FOR FLANGED CIRCULAR OPENING

When utilizing thermal airflow occurring in a process, exhaust airflow should be greater than the process airflow. This will minimize air spillage at the rim of the hood.

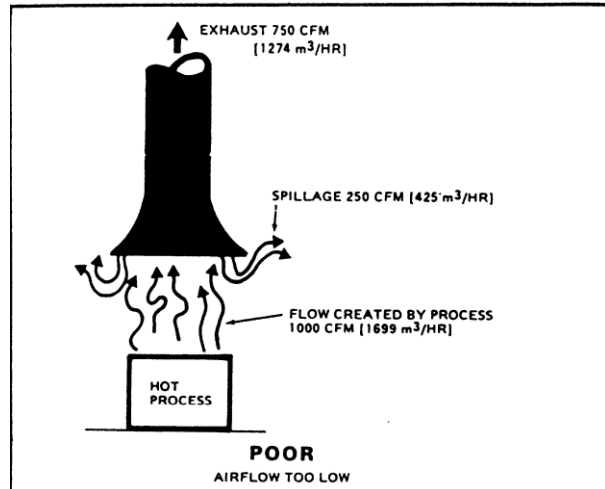

FIGURE 9 – MAINTAIN ADEQUATE AIRFLOW

For further information on ventilation and hood design, refer to a more complete source, such as:

INDUSTRIAL VENTILATION, by American Conference of Governmental Industrial Hygienists, published by Committee on Industrial Ventilation, Lansing, Michigan 48106.

HANDBOOK OF VENTILATION FOR CONTAMINANT CONTROL, by Henry J. McDermott, published by Ann Arbor Science, Box 1425, Ann Arbor, Michigan 48106.

INSTALLATION

WHEN INSTALLING THIS PRODUCT

1. Read these instructions carefully. Failure to follow them could damage the product or cause a hazardous condition.
2. Check the ratings given in the instructions and on the product to make sure the product is suitable for your application.
3. Installer must be a trained, experienced service technician.
4. After installation is complete, check out product operation as provided in these instructions.

UNPACKING

The air cleaner mounting brackets and hardware are packed in one box. Check all air cleaner components carefully when unpacking. Remove all shipping cardboard. Be sure to inspect all packing materials before discarding them.

- CAUTION -

Do not connect the power source until after the air cleaner is mounted.

Be sure to turn the air cleaner off before servicing. The air cleaner motor may be equipped with an automatic thermal overload. Should the motor become overheated, it will automatically stop, and then start after a sufficient period of cooling.

If the air cleaner must be turned on for an electrical check, be extremely careful to avoid electrical shock. Also, take care when working near the air cleaner's moving parts.

STAND MOUNTING

Securely place the air cleaner on an appropriate stand or cart and locate as close to the contaminant source as possible. The position should also allow satisfactory distribution of air from the outlet of the air cleaner. If a source capture hood, plenum and hose are used, observe the instructions in PLANNING THE INSTALLATION for selecting a suitable location for the unit.

OVERHEAD MOUNTING

When installing the air cleaner in an overhead location, position the air cleaner as close to the contaminant source as possible. This increases

the air cleaner's effectiveness. It is important to select an overhead mounting location for the air cleaner that provides easy access for cell cleaning and maintenance. Do not place a ladder against the air cleaner when it is mounted overhead in order to gain access to the air cleaner interior.

Be certain that the mounting hardware (not included) from the air cleaner to the ceiling provides adequate strength and stability and that it is securely attached to the overhead structure. Do not fasten the air cleaner to a false ceiling, plaster or plasterboard. In some cases, it may be necessary to construct supports that will bear the weight of the air cleaner when it is hung in an overhead location.

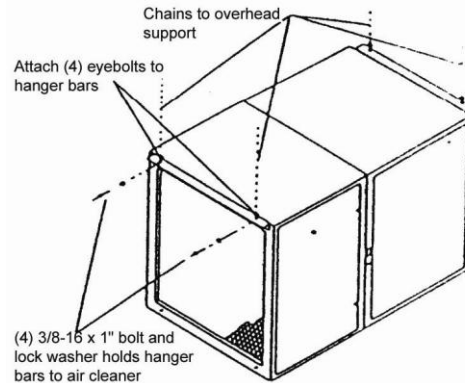

**FIGURE 10 – MOUNTING F66 OVERHEAD
F73 USES 3/8" EYEBOLTS PROVIDED**

SOURCE CAPTURE PLENUM (optional)

1. Install using 4 included 3/8" bolts using existing weld nuts on air cleaner.
2. Fasten the plenum to the air cleaner using No. 10 sheet metal screws, 1/2" to 3/4", (12.7mm to 19mm) long (not furnished).
3. Connect the hose length to the desired plenum flange using hose clamps (available). Block off unused plenum openings with caps, available separately.
4. Route the hose(s) to the source capture hood. Support the hose(s), as necessary, using hangers and support bands. Support bands on the hose should be at least 2 1/4 inches (57.2 mm) wide and placed at 5 foot (1.52 m) intervals. Do not pinch or flatten the hose.
5. Hood size and location should be determined by an accepted authority or reference, such as the INDUSTRIAL VENTILATION MANUAL, to meet applicable codes and ordinances for a particular application.

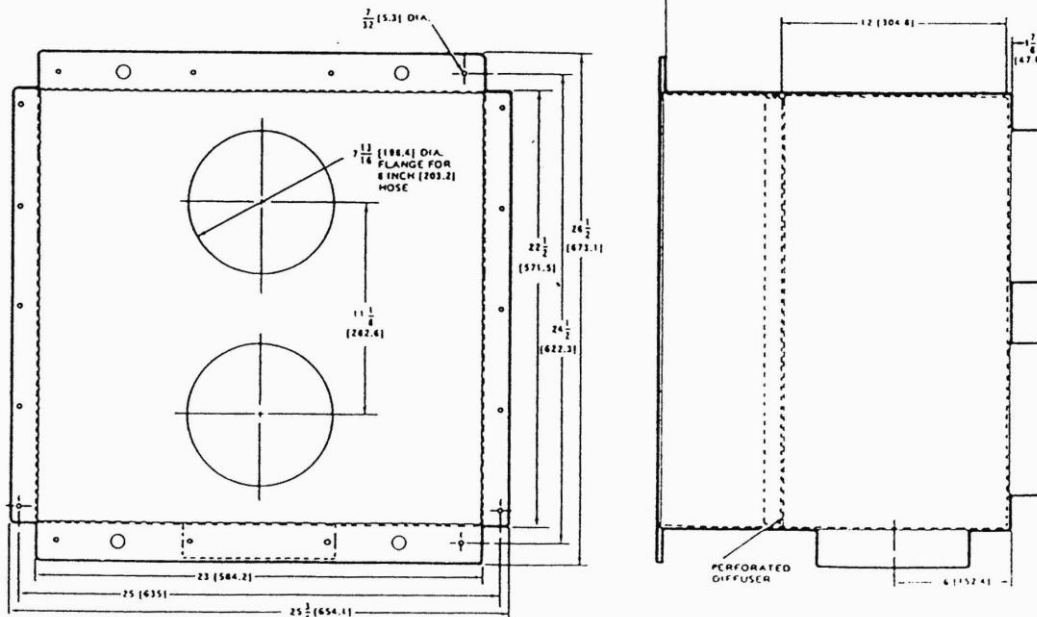

FIGURE 11 – 66 SIZE SOURCE CAPTURE PLENUM DIMENSION

- CAUTION -

This procedure should be attempted only by persons qualified to install electrical wiring.

ELECTRICAL INSTALLATION

Cord Connected

The power cord must not be concealed above the ceiling or behind the walls. Route the power cord so it will be out of the way of employees.

The air cleaner models have 10-foot power cords with standard three-prong plugs. There must be a standard grounded outlet provided within 10 feet of the air cleaner. Do not use an extension cord. The three phase air cleaner models have a 10-foot power cord. An appropriate plug is required since it is not standard with the air cleaner.

Conduit Connected

All wiring must comply with applicable codes and ordinances. Be sure the power source is compatible with the model ordered.

It is recommended that No. 12 gauge wire be used to complete the wiring from the air cleaner wiring compartment to the power source. However, be certain to comply with local codes. A green wire is provided in the wiring compartment for a

grounding connection. Proper grounding of this device is mandatory for operation and safety.

- a. Remove the wiring compartment cover and the 10-foot power cord.
- b. Run wires through the conduit. Attach the conduit to the desired 1/2 or 3/4" knockout.

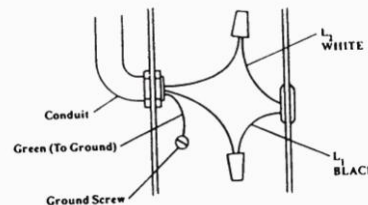

FIGURE 12 – SINGLE PHASE

- c. Use the wire nuts to make connections in the wiring compartment. See Fig. 12 for single phase models. See Fig. 13 for three phase models.
- d. Re-attach the wiring compartment cover.

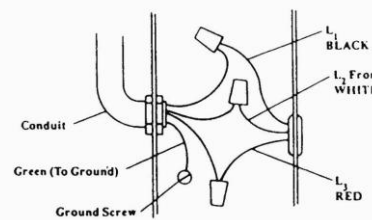

FIGURE 13 – THREE PHASE

CHECKOUT AND OPERATION

CHECKOUT

Before operating the air cleaner, check out the installation using the following procedures:

1. Make sure the air cleaner is oriented for good air circulation where it will not interfere with personnel and material traffic. Keep out of fire lanes and away from overhead cranes.
2. Make sure the air cleaner is securely mounted to the building structure.
3. Clean the inside of the cabinet, the outside of the cabinet and the installation area.
4. Make sure that the blower cover and the wiring compartment cover have been reinstalled securely.
5. Make sure the prefilter and the primary filter are properly oriented and the airflow arrows are pointing toward the blower.
6. Adjust the discharge grille to direct the airflow.

OPERATION

When the electronic air cleaner is energized, the blower produces an airflow which conveys contaminated air into the air cleaner inlet. Particles that are too small to be caught by the prefilter screen are given an intense electrical charge in the ionizing section of the electronic cell.

As the air carries these charged particles into the collecting section of the electronic cell, they are hurled against metal plates by the force of a powerful electrical field. These particles cling to the metal plates, and the clean air passes through a postfilter screen and the blower compartment and reenters the building space.

Turn on the air cleaner control switch. Make sure the blower is providing a strong discharge, and the indicator light is on. Pushing the test button will momentarily short out the collector section of the electronic cells. Arching indicates that the cells are energized properly.

On belt drive models, the blower should be rotating in the direction shown on Fig. 14. On direct drive models reference the arrow on the blower. **If the air cleaner is a three phase air cleaner, correct the rotation by interchanging any two power leads.**

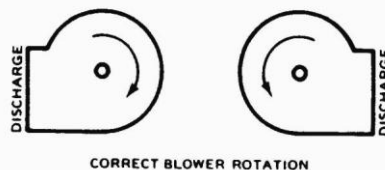

FIGURE 14 – BLOWER ROTATION

ADJUSTMENTS

The blower capacity of the air cleaner is factory-set at the maximum volume of air, considering the filter efficiency and other options ordered, such as impingers plenums and carbon.

On belt drive models if increased or decreased airflow is desired, it can be accomplished by adjusting the variable sheave on the motor. It is very important to measure the amperage before and after the adjustments are made on the variable motor sheave to insure that the motor is not overloaded. The rated amperage is listed on the schematic on motor itself.

1. Unplug the air cleaner and open the access door to the blower section of the air cleaner.
2. Loosen the two bolts locking the end of the motor rail in position. Remove the belt.
3. Loosen the Allen setscrew on the face of the motor sheave.

4. Rotate the sheave into a position that gives the desired blower capacity.
5. Measure the amperage after the sheave adjustment to insure that you do not exceed the rated amperage

NOTE: When the sheave is rotated all the way into the shaft, the blower capacity is at its maximum. When the sheave is rotated five turns out on the shaft, the blower capacity is at its minimum. **DO NOT ROTATE THE ADJUSTABLE SHEAVE MORE THAN FIVE TURNS OUT ON THE SHAFT.** The sheave may already be adjusted one or more turns out on the shaft.

SERVICE

- CAUTION -

Always disconnect the power to the air cleaner before working on or near the air cleaner.

Do not place a ladder against the air cleaner when it is mounted in an overhead position.

The air cleaner was designed to support only the weight of the internal components; motor, blower, and filters. Do not climb in or on the air cleaner.

WHEN TO WASH THE ELECTRONIC CELLS

To maintain peak performance and efficiency, the electronic cells and per/post filters in the electronic air cleaner must be washed regularly. This washing is necessary to remove the dirt particles accumulated during the air cleaning process. The cells and filters should be visually checked for dirt or lint. Experience will probably be the best indicator of how often the cells and screens should be cleaned. For example, when operating in a thick smoke or particularly dirty atmosphere, the cells may need washing twice a week. If the dirt accumulation is light, the period between washings can be lengthened.

Air Quality Engineering, Inc. recommends using an alkaline detergent, and offers part number 45008 detergent for washing cells. If the alkaline detergent proves inadequate because of excessive buildup of captured contaminants, the use of physical force (such as, high pressure air, water, or steam) may be required. Or depending on the application, Air Quality Engineering part number 45026 may be required.

CLEANING THE PRE/POST FILTERS

Remove the pre/post filter and shake out or vacuum the accumulated contaminants. The pre/post filter can also be soaked in the alkaline detergent solution, or use high pressure water, air or steam cleaning on the pre/post filter.

NOTE: If the pre/Postfilter needs washing, wash them after the cell(s) have been washed. The lint residue from the pre/post filter will contaminate the wash water and can deposit inside the cell(s).

- CAUTION -

Do *not* splash the cleaning solution in your eyes and avoid prolonged contact with your skin. Keep the detergent and solution out of the reach of children. Be sure to follow the cleaning solution label instructions for use or storage.

Be extremely careful when working with electronic cells and filters. The edges of the cells and filters may be sharp.

When cleaning the cells and filter be sure to wear appropriate protective gear, especially goggles and gloves. Skin contact with either alkaline or acid detergent solution should be avoided.

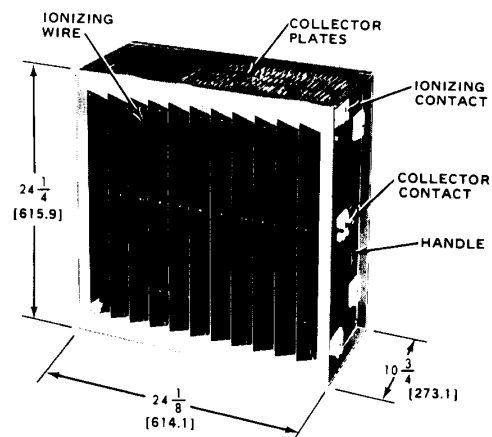

FIGURE 15 – PN 38010, ELECTRONIC CELL COMPONENTS. DIMENSIONS IN INCHES [MILLIMETERS SHOWN IN BRACKETS].

THE ALKALINE DETERGENT SOLUTION CLEANING METHOD

1. Mix the solution according to the instructions.
2. Soak the cells for the time indicated on the cleaning solution label. Before removing the cells, slosh them around several times.
3. Rinse the cells with a fine spray.
4. Soak the cells in HOT water and let the water drain. If the water draining from the cells feels slippery, they need more rinsing.
5. Inspect the cells for cleanliness. If any dirt remains, it probably indicates that the cells should be washed more frequently. Repeat this soaking procedure, if needed, to get the cells clean.

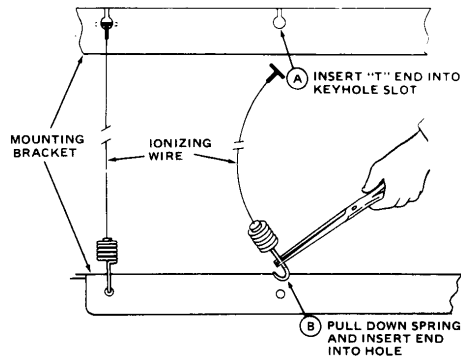

FIGURE 16 – METHOD OF REPLACING THE IONIZING WIRE

After routine washing, a noticeable buildup may remain on some parts of the cells. This is normal and has only a negligible effect on performance.

After a long period of service, perhaps every one to three years, the electronic cells should be removed from the cabinet and given an extra thorough washing. In many areas, professional cell cleaning services are available or they may be returned to Air Quality Engineering for a professional cleaning.

REPLACE THE ELECTRONIC CELLS AND PRE/POST FILTERS

Before replacing the electronic cells, be sure to visually check the cell for bent or damaged collector plates or broken ionizing wires.

1. Replace the electronic cell so that the arrow on the handle-side of the cell points in the direction of the airflow.
2. Insert the pre/post filters in the channels.
3. Close the filter access door.

NOTE: The washed cell may be replaced in the cabinet even though it is still wet. The system light may come on during the normal drying period.

IONIZING WIRE REPLACEMENT

To replace the ionizing wires, remove the electronic cell from the cabinet and proceed as follows:

1. Remove all of the broken wire from the cell mounting brackets. See Fig. 16.
2. Install the new wire. Insert the "T" end of the ionizing wire into the keyhole spring until the hooked end can be secured in the mounting bracket hole.
3. Use a long nose pliers and carefully pull the spring until the hooked end can be secured in the mounting bracket hole.

TROUBLESHOOTING

- WARNING -

The following instructions are intended for qualified service personnel only. Dangerous line voltage circuits are exposed during this procedure. Not normally lethal, the 10,000Vdc output from the power supply can produce a painful shock. Disconnect the power before servicing the unit.

INDICATOR LIGHT FLICKERS / UNIT MAKES ZAPPING NOISES

Some flicker is inherent in neon indicator lights and is not an indication that anything is wrong. If the indicator light blinks off and back on and is accompanied by a clicking or zapping noise that is frequent, it is an indication that the electronic collector cell(s) may be dirty or damaged. Washing the cells should clean the cell. An occasional blink or snapping is normal.

If washing the cells does not eliminate the noise remove the cells and investigate them looking for bent collector fins or a large particle stuck in the cells. Check the contacts on the cells and inside the unit for a possible bad connection. Remove any particles taking care not to bend the collector plates or break any ionizing wires.

If any ionizing wires are broken reference the parts list for replacement.

If a collector plate is bent causing the arcing (bug zapper noise), one may attempt to bend the plate back to an original position with a duckbilled pliers. Care must be used as further damage can be caused by stretching the aluminum plates, which can render the cell unrepairable. Air Quality Engineering will evaluate cells at no charge and provide free repair estimates. This is highly recommended before untrained personnel attempt repairs. Please contact Air Quality Engineering at 1-800-328-0787 for assistance.

INDICATOR LIGHT IS NOT ON

Check to see if the cell access door is closed properly. The indicator light will not be lit if the door is open and the electronic cells will not be energized.

Remove the electronic collector cell(s) and close the door. If the light comes back on, there is a short in at least one collector cell. A short can be a result of the cell(s) being excessively dirty, a large piece of contaminant shorting the fins, or a physical damage such as a collector fin being bent out of shape and touching an adjoining fin. Wash the cells to clean them if they appear dirty. Visually inspect the cell for large particulate that may be bridging two adjoining collector fins or for physical damage. If damage is identified, repairs should only be performed by trained personnel as improper repairs may result in unreparable damage. Please contact Air Quality Engineering, Inc. at 1-800-328-0787 for assistance.

If the indicator light does not come on with the cells removed and the door closed, use a voltmeter to confirm that there is indeed voltage at the input of the power supply. If there is voltage at the power supply, but no indicator light, the power supply should be replaced. The indicator light itself has a very low failure rate.

INDICATOR LIGHT IS OUT; BLOWER IS NOT DISCHARGING AIR

Most likely the problem is with the source voltage. Measure the voltage at the wiring compartment on the air cleaner. Check the circuit breaker or fuse are the source voltage. If proper voltage is measured at the air cleaner compartment, call Air Quality Engineering at 1-800-328-0787.

INDICATOR LIGHT IS ON AND THE BLOWER IS DISCHARGING AIR, BUT TEST BUTTON DOES NOT PRODUCE AN ARCING SOUND

The problem is with the high voltage contacts from the power door to the contacts on the electronic cells. Check that the cells are installed properly with the airflow arrows pointing towards the blower. If the problem is not with the contact points then the problem is with the collector plates on the cells. Check for bent or extremely dirty collector plates.

INDICATOR LIGHT IS ON; BLOWER IS NOT DISCHARGING AIR

The most likely cause would be that the motor is overheating. This would cause the thermal protection to shut the motor off until the motor cools. The thermal protection will not affect the high voltage power supply or electronic cells. If the motor sheave has been adjusted to increase airflow, the current will have to be measured to insure that the current is not exceeding the rating for the air cleaner. This would cause the motor to overheat.

ELECTRICAL SCHEMATICS

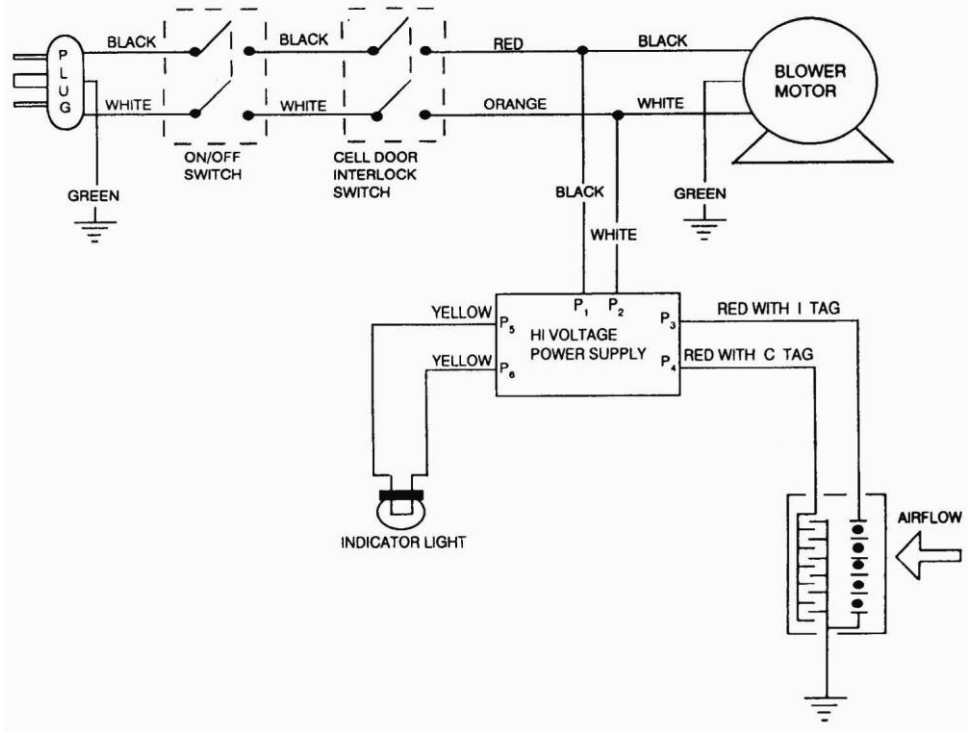

SINGLE PHASE

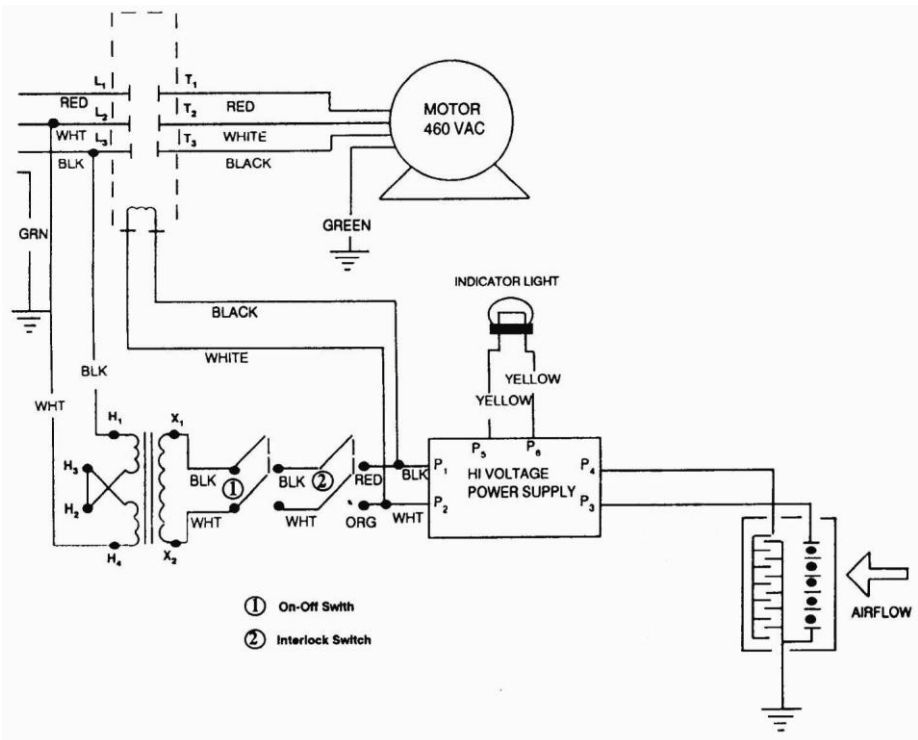

3 PHASE – 230V or 460V

PARTS LIST

F33 BELT DRIVE BLOWER SECTION

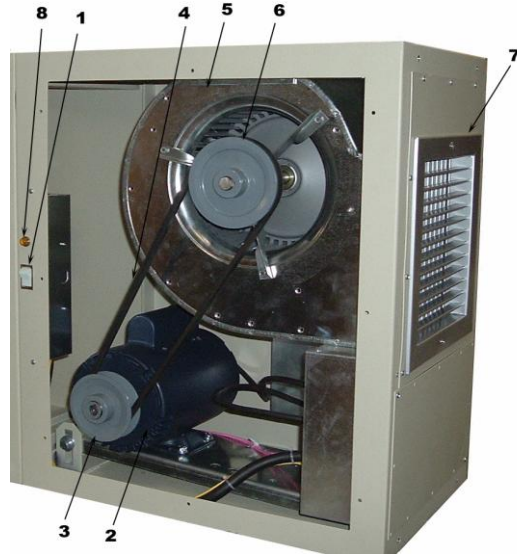

NO.	DESCRIPTION	PART NO.
1	On/Off Switch	10140
Not shown	Interlock switch	10079
Not shown	Power Supply 120V	07098
Not shown	Power Supply 230V	07100
Not shown	Aluminum Mesh Impinger for prefilter section 07072	41202
Not shown	Pre/Post Impinger F33	41075
Not shown	Electronic Cell 12" x 24" x 10-1/2"	38003
Not shown	Ionizing wire	38005
Not shown	Carbon Postfilter F33	41169
2	Motor 1 HP 115/208-240 single phase belt drive 5/8" shaft	40013
	Motor 1.5 HP 115/208-240 single phase belt drive 5/8" shaft	40037
	Motor 2 HP 208V-240V single phase belt drive 5/8" or 7/8" shaft	40039
	Motor 1 HP 208V-240V / 460V 3 phase, belt drive 5/8" shaft	40009
	Motor 2HP 208V-240V / 460V 3 phase, belt drive 5/8" or 7/8" shaft	40040
3	Motor Sheave Variable 1VL44-5/8	30166
	Motor Sheave Variable 1VM50-5/8	30583
	Motor Sheave Variable AK56-5/8	30577
	Motor Sheave Variable 1VL44-7/8	30534
	Motor Sheave Variable 1VL50-7/8	30362
	Motor Sheave Variable 1VL56-7/8	30715
4	Belt A40	30603
	Belt A41	30602
	Belt A42	30011
	Belt A43	30543
	Belt A44	30531
	Belt A45	30581
	Belt A46	30582
	Belt A47	30234
5	Blower 3/4" shaft	37020
6	Blower Pulley AK41-3/4	30601
	Blower Pulley AK46-3/4	30599
	Blower Pulley AK51-3/4	30600
	Blower Pulley AK56-3/4	30019
	Blower Pulley AK64-3/4	30167
7	Exhaust Grille	30530
8	Indicator Light	10097

F66 BELT DRIVE BLOWER SECTION



NO.	DESCRIPTION	PART NO.
1	On/Off Switch	10140
Not shown	Interlock switch	10079
Not shown	Contact Board assembly - Cabinet	46175
Not shown	Power Supply 120V single phase	07082
	Power Supply 240V single phase	07084
	Power Supply 3 phase	07082
Not shown	Pre/Post Impinger F66	41052
	Pre/Post Heavy Duty Impinger F66	41092
	Electronic Cell 12" x 24" x 10-1/2"	38003
	Ionizing wire	38005
2	Motor 1 HP 115/208-240 single phase belt drive 5/8" shaft	40013
	Motor 1.5 HP 115/208-240 single phase belt drive 5/8" shaft	40037
	Motor 2 HP 208V-240V single phase belt drive 5/8" or 7/8" drive	40039
	Motor 1 HP 208V-240V / 460V 3 phase, belt drive 5/8" shaft	40009
	Motor 2HP 208V-240V / 460V 3 phase, belt drive 5/8" or 7/8" shaft	40040
	Motor 3HP 208V-240V / 460V 3 phase, belt drive 7/8" shaft	40041
3	Motor Sheave Variable 1VL44-5/8	30166
	Motor Sheave Variable 1VM50-5/8	30583
	Motor Sheave Variable AK56-5/8	30577
	Motor Sheave Variable 1VL44-7/8	30534
	Motor Sheave Variable 1VL50-7/8	30362
	Motor Sheave Variable 1VL56-7/8	30715
4	Belt A40	30603
	Belt A41	30602
	Belt A42	30011
	Belt A43	30543
	Belt A44	30531
	Belt A45	30581
	Belt A46	30582
	Belt A47	30234
5	Blower 3/4" shaft	37012
6	Blower Pulley AK41-3/4	30601
	Blower Pulley AK46-3/4	30599
	Blower Pulley AK51-3/4	30600
	Blower Pulley AK56-3/4	30019
	Blower Pulley AK64-3/4	30167
7	Exhaust Grille	30486
8	Indicator Light	10097
9	Transformer (3Ph only)	10075
10	Relay, contact (3Ph only)	10078

F66 DIRECT DRIVE BLOWER SECTION



NO.	DESCRIPTION	PART NO.
1	On/Off Switch	10140
Not Shown	Interlock Switch	10079
Not Shown	Contact Board assembly - Cabinet	46175
Not Shown	Power Supply 120V single phase	07082
	Power Supply 240V single phase	07084
	Power Supply 3 phase	07082
Not Shown	Pre/Post Impinger F66	41052
	Pre/Post Heavy Duty Impinger F66	41092
	Electronic Cell 12" x 24" x 10-1/2"	38003
	Ionizing wire	38005
2	Inlet Cone, 2 Hp & 3 Hp	37036
	Inlet Cone, 5 Hp	37033
3	Wheel, 2 Hp	37040
	Wheel, 3 Hp	37035
	Wheel, 5 Hp	37032
4	Motor, 2 Hp 3 Ph	40071
	Motor, 3 Hp 3 Ph	40070
	Motor, 5 Hp 3 Ph	40056
5	Exhaust Grille	21782
6	Relay, Contact	10078
7	Transformer	10075

F73 BLOWER SECTION

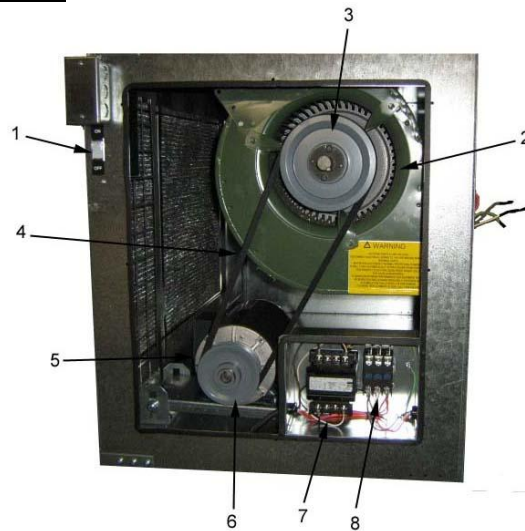

NO.	DESCRIPTION	PART NO.
1	On/Off Switch	10140
Not Shown	Interlock Switch	10079
Not Shown	Power Supply 120V single phase	07082
	Power Supply 240V single phase	07084
	Power Supply 3 phase	07082
Not Shown	Pre/Post Filter 24" x 24" x 1"	41113
	Pre/Post Filter 12" x 24" x 1"	41246
	Electronic Cell 24" x 24" x 10-1/2"	38010
	Electronic Cell 12" x 24" x 10-1/2"	38003
	Ionizing wire	38005
	Carbon Filter 24"x 24" x 1"	41171
2	Blower (2 & 3 HP belt drive) – 3/4" shaft	37027
	Blower (5HP belt drive) – 1" shaft	37037
3	Blower Pulley AK 41-3/4"	30601
	Blower Pulley AK 46-3/4"	30599
	Blower Pulley AK 51-3/4"	30600
	Blower Pulley AK 56-3/4"	30019
	Blower Pulley AK 64-3/4"	30167
	Blower Pulley BK60H (needs hub)	30701
	Blower Pulley BK70H (needs hub)	30716
	Hub 3/4"	30717
	Hub 1"	30702
4	Belt B46	30703
	Belt B47	30234
	Belt B48	30732
	Belt B49	30733
	Belt B50	30718
	Belt B51	30719
	Belt B52	30720
5	Motor 2HP 208V-240V single phase, belt drive 5/8" or 7/8" shaft	40039
	Motor 2HP 208V-240V / 460V 3 phase, belt drive 5/8" or 7/8" shaft	40040
	Motor 3HP 208V-240V / 460V 3 phase, belt drive 7/8" shaft	40041
	Motor 5HP 208V-240V / 460V 3 phase, belt drive 1-1/8" shaft	40061
6	Motor Sheave Variable 1VL44-5/8	30166
	Motor Sheave Variable 1VM50-5/8	30583
	Motor Sheave Variable AK56-5/8	30577
	Motor Sheave Variable 1VL44-7/8	30534
	Motor Sheave Variable 1VL50-7/8	30362
	Motor Sheave Variable 1VL56-7/8	30715
	Motor Sheave Variable 1VP68-1-1/8	30700
7	Transformer	10075
8	Relay, Contact	10078

CERTIFICATE OF WARRANTY

THREE-YEAR LIMITED WARRANTY

Air Quality Engineering, Inc. (AQE), warrants to the original purchaser, subject to the conditions below, that if the "Product" covered by this warranty should fail to perform by reason of improper workmanship or material, AQE will during the period of three (3) years from the date of original purchase either (i) replace the product or (ii) provide all necessary parts to repair the product without charge. The decision to replace the product or the necessary parts shall rest solely with AQE. This three-year limited warranty does not apply to main filter elements. AQE will replace without charge the main filter elements during the period of thirty (30) days from the date of original purchase if the main filter elements fail to perform by reason of improper workmanship or material. This warranty is valid only under the following conditions:

CONDITIONS

1. **REGISTRATION:** The purchaser's completion and mailing of the Registration Card to Air Quality Engineering, Inc., 7140 Northland Drive North, Minneapolis, Minnesota 55428-1520 within 30 days of original purchase.
2. **AUTHORIZATION:** The purchaser will contact AQE at (800) 328-0787 for authorization, returned goods number (RGA) and the shipping address. AQE will direct the purchaser to either return the necessary parts or the product at AQE's option.
3. **PROPER DELIVERY:** The shipping, freight prepaid or delivery of the parts or the product to AQE in either its original carton or in a carton assuring similar protection of the product with the returned goods number (RGA) clearly displayed on the outside of the carton.
4. **UNAUTHORIZED REPAIR:** A showing by the original purchaser that the product has not been altered, repaired or serviced by anyone other than an authorized service technician using genuine AQE parts.
5. **UNAUTHORIZED PARTS:** A showing by the original purchaser that the product has had only genuine AQE parts and filters used in its operation and maintenance.
6. **SERIAL NUMBER INTACT:** A showing by the original purchaser that the serial number has not been altered or removed.
7. **MISUSE:** A showing by the original purchaser that the product has not been involved in an accident, freight damaged, misused, abused or operated contrary to the instructions contained in the Owner's Manual.

Air Quality Engineering, Inc.'s, sole responsibility shall be to repair or replace the product within the terms stated above. AQE SHALL NOT BE LIABLE FOR ANY CONSEQUENTIAL DAMAGES RESULTING FROM ANY BREACH OF WARRANTY, EXPRESS OR IMPLIED, APPLICABLE TO THIS PRODUCT. Some states do not allow the exclusion or limitation of consequential damages so this limitation may not apply to you.

THIS WARRANTY IS IN LIEU OF ALL OTHER WARRANTIES, EXPRESS OR IMPLIED, AND THE WARRANTIES OF MERCHANTABILITY AND FITNESS FOR A PARTICULAR PURPOSE ARE HEREBY EXCLUDED BEYOND THE THREE-YEAR DURATION OF THIS WARRANTY. Some states do not allow limitations on how long an implied warranty lasts so the above limitation may not apply to you.

This warranty gives you specific legal rights and you may also have other rights that vary from state to state.

**AIR QUALITY ENGINEERING, INC.
7140 NORTHLAND DRIVE NORTH
BROOKLYN PARK, MINNESOTA 55428-1520**

**TOLL FREE: 1-800-328-0787
TELEPHONE: (763) 531-9823
FAX: (763) 531-9900**

MANUFACTURER & WORLDWIDE DISTRIBUTOR OF SMOKEMASTER® AIR CLEANING SYSTEMS