

## Supplying Clean Air to Industry

Let Air Quality Engineering use our decades of air cleaning experience to help solve your industrial air quality problems and improve your plant's productivity.



Air Quality Engineering uses proven technologies and a comprehensive range of equipment to handle harmful airborne industrial contaminants such as coolant mist, welding smoke, and grinding dust. Our industrial air cleaners are easily installed and available for general background air cleaning or source capture applications.



The M73 air cleaner is a media filtration unit featuring an ESF gradient density non-shedding polypropylene filter for long filter life and high efficiency to effectively remove smoke, mist, and dust particulate. It is designed for source capture and ambient air cleaning applications within environments such as grinding, welding, foam cutting, rubber extruding, injection molding and dust associated with warehousing facilities.

Air Quality Engineering has packed the M73 with standard features to extend filter life and reduce installation and maintenance costs:

- 5HP backward inclined blower assists in extended filter life
- Two extended service filters assists in reducing long term maintenance costs
- Motor circuitry included to reduce additional installation costs



The M73 provides a maximum recommended airflow of 5500 CFM. It is designed with multi-stage filtration: pleated pre-filtration, high efficiency long service life primary filtration, and an optional bulk refillable odor module containing up to 576 lbs. vapor filtration media.

**Air Quality Engineering stands behind the quality of the M73 with a limited 36 month warranty.**



**AIR QUALITY  
ENGINEERING**

Air Quality Engineering, founded in 1973, is proud to offer a continued, superior level of experience in manufacturing complete air filtration systems that provide the highest performance, efficiency, and capacity for the money. Our sales and engineering team's mission is to identify the most cost-effective, high-quality solutions for our customers' needs, whether commercial, industrial or residential.

# M73 - Media Air Cleaner

<b>Model</b>	<b>M73</b>
<b>Maximum Recommended Airflow</b>	5500 CFM
<b>Cabinet</b>	16 gauge steel
<b>Power Input</b>	208-240V/60/3 Phase 440-480V/60/3 Phase International voltages available
<b>Motor Options</b>	5HP
<b>Blower Options</b>	Direct drive backward inclined
<b>Standard Features</b>	Dirty filter gauge Motor starter and control circuitry
<b>Filter Options Prefilter</b>	Two 24" x 24" x 4" pleated prefilter Four 24" x 24" x 2" mist impingers
<b>Filter Options Primary</b>	Two 24" x 24" x 12" Polypropylene ESF
<b>Accessories</b>	Custom source capture plenum Additional prefiltration Odor module Electrostatic module Wall mount arms



## Weight Shipping

465 lbs.

## Installed

405 lbs.

Specifications subject to change without notice.

This unit is required to be used in source capture configurations only when installed in California. Units purchased for installation in California must be purchased with Air Quality Engineering supplied and installed source capture plenums.

## COMPLETE METALWORKING SOLUTIONS

(800) 991-4225

ISO Certified

[www.ahbinc.com](http://www.ahbinc.com)

[customerservice@ahbinc.com](mailto:customerservice@ahbinc.com)

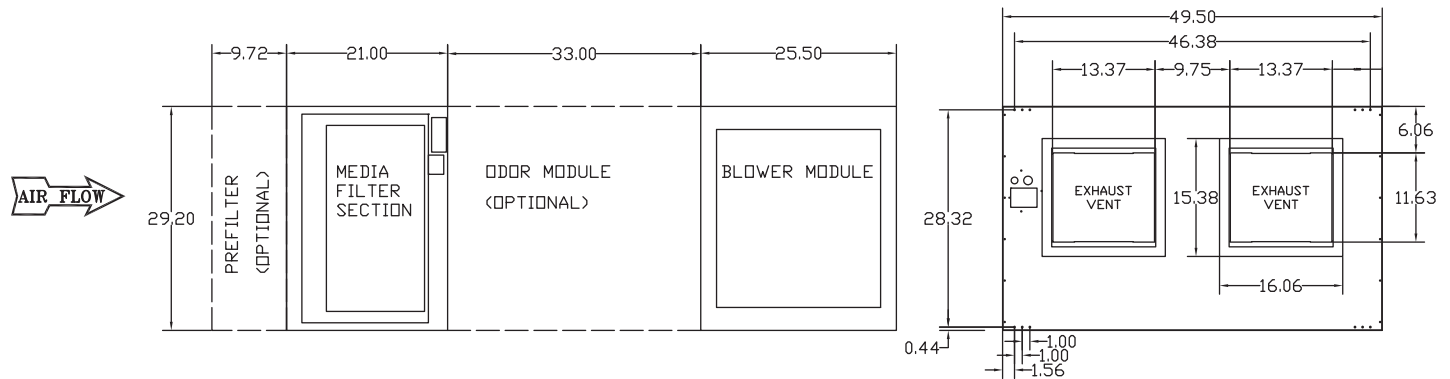

7140 Northland Drive North, Brooklyn Park, MN 55428-1520, USA

PHONE: 800-991-4225

EMAIL: [customerservice@ahbinc.com](mailto:customerservice@ahbinc.com)