



TYPHOON WX SERIES

WET DUST COLLECTORS



AHB

TOOLING & MACHINERY

COMPLETE METALWORKING SOLUTIONS
(800) 991-4225 www.ahbinc.com
ISO Certified customerservice@ahbinc.com



The stainless steel wet dust collector excels at capturing combustible/hazardous dust from your plant air. The blower draws air through DiversiTech's proprietary water-tree baffle design, creating a cascading water effect that removes particles as small as 3 micron from the airstream. Dust is filtered through contact with water droplets and contained in the bottom of the collector for safe removal at necessary maintenance intervals. Water levels are automatically controlled with valves and sensors, including interlock functions to meet NFPA and OSHA codes.

NFPA 484 Compliant

In 2015, NFPA updated the 484 standard requiring an interlocked offline vent fan, to prevent build-up of hydrogen gas. Optional HEPA filters also now require a high temperature alert. Diversitech's CSA/UL certified control panel now supports:

- Offline Vent Fan included
- HEPA Filter high temperature alert (option)

100% Duty Cycle

The Typhoon WX collector's new ultrasonic water sensor monitors and automatically adds water as needed, even while the machine is in operation.

- Online adaptive water-level control
- Automatically adds water, offline & online
- Safety overflow drain

Benefits:

- Capture-at-source for Cleaner Air
- Complies with NFPA guidelines for Combustible Dust

Features:

- Ultrasonic water level sensor
- NEMA 12 control panel w/LCD display
- Mainline Interlock Switch
- Anti-corrosion stainless steel #304 construction
- High efficiency, non-sparking blower wheel
- Transparent Lexan doors, with easy access clasps
- Low-cost mist eliminator afterfilters



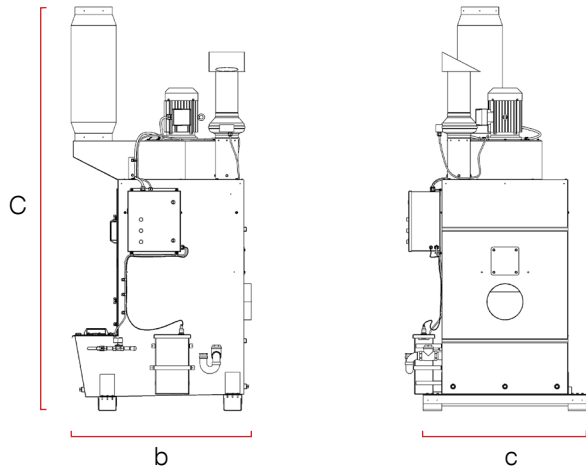

Options



Ducted downdraft table in four standard sizes



WV-55 Sludge-Vac Removal Vaccum



High-efficiency Hepa Afterfilter kit (MERV 17)



Bag strainer system to remove dust and sludge

*Custom configurations available on request.

Dimensions **

Model	Inlet Collar Diameter (in.)	Footprint (in.)			Net Weight (lbs.)	Water	
		Length [b]	Height [C]	Width [d]		Supply (in.)	Drain (in.)
WX-1200	6	34	86	32	395	1/2" NPT	1 1/2" NPT
WX-3000	10	47	109	44	738	1/2" NPT	1 1/2" NPT
WX-5000	16	61	117	57	923	1/2" NPT	1 1/2" NPT
WX-6500	16	67	129	67	1185	1/2" NPT	1 1/2" NPT

1. Water Level is marked on each unit.

** Product dimensions are based on base-models and may vary depending on selected product features. Please contact us for an accurate shipping quote.

Technical Specifications

Model	Water Fill System	Nominal Airflow (CFM)	Tank Capacity (Gallons)	Motor (H.P.)	Power				Noise @5ft. (dB)
					Phase (hz)	@230V (amps)	@460V (amps)	@575V (amps)	
WX-1200	auto	1200	16	3.0	3P / 60Hz	9.6	4.8	3.9	74
WX-3000	auto	2000-3500	40	5.0	3P / 60Hz	15.2	7.6	6.1	78
WX-5000	auto	3000-5000	80	10.0	3P / 60Hz	28.0	14.0	11.0	78
WX-6500	auto	4000-6500	80	15.0	3P / 60Hz	34.0	16.9	14.0	80

1. For 1200, Airflow @ 2" external static pressure.

2. For WX-3000, WX-5000, WX-6500, Airflow @ 2.5" external static pressure.

HEAD OFFICE

1200 55th Avenue
Montreal, QC H8T 3J8

DISTRIBUTION CENTERS

CANADA Montreal, QC Toronto, ON
UNITED STATES Trenton, NJ Chicago, IL Reno, NV

CONTACT US:

Toll Free: 800-991-4225