



COMPLETE  
METALWORKING  
SOLUTIONS

(800) 991-4225  
www.ahbinc.com  
ISO Certified  
customerservice@ahbinc.com



# Cartridge Series Filtration Systems

## PMF-623-D-P-T-3PH

The Ebbco 623 Series Filtration Systems are designed for Precision Machining Application to Keep Particulate From Building Up In The Machine Tool. Through a series of cartridge filters the 623 Series Filtration Units will Increase Oil or Coolant Life, Provide a Better Part Finish And Reduce Part Rejection.



### PMF-623 Filtration System Scope :

Fluid Enters the Filtration System dirty tank through a Prefilter Screen, A Vertical Seal-less Pump then send the fluid at the proper flow rate and pressure through a two 623 Filter Cartridge, where it is filtered to a set micron and then stored in the clean side of the tank. An Optional Machine Feed Pump supplies the clean fluid back to the machine tool at the proper flow rate and pressure specified by the machine tool manufacturer. An optional chiller will chill the fluid to set temperature to avoid thermal distortion.

### Standard Features:

- ◆ Retrofit to Existing Machine Tanks
- ◆ Heavy-Duty Filter Pump with Strainer Basket for Pump protection
- ◆ Dual Single Cartridge Filter Vessel Containing a Micron Rated Filter Cartridges
- ◆ Machine Feed Pump
- ◆ Optional Chiller Available
- ◆ Optional Filter Service Beacon

# Cartridge Series

## PMF-623-D-P-T-3PH

**Machine Capabilities:** 1- Single Machine Standard

**System Dimensions:** 69.25" L x 24" W x 36" H



### System Features:

- ◆ Self Cleaning Clean/Dirty Carbon Steel Tank with Prefilters
- ◆ Dual Filter Vessel Containing a Micron Rated Filter Cartridges
- ◆ Nema 12 Electrical Enclosure with Rotary Disconnect and Overload Protection
- ◆ Filter Service Beacon

### System Specifications

#### Tank

Gallon Capacity 75 gallons (Apporx)

#### Filter Vessel

Model PMF-MWF-623

Cartridge Quantity 2 (Two)

#### Filter Pump

Heavy-Duty Vertical Sealless

#### Machine Feed Pump

25 GPM @ 125 PSI

#### Chiller (Optional)

Model PMF-12000IL-3

BTU Rating 12,000 BTU/HR

#### Voltage

230 or 460 Vac Three Phase

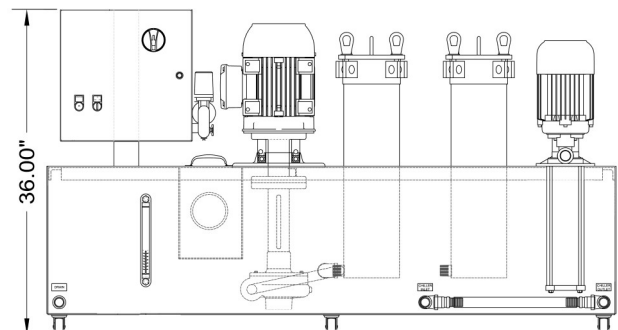
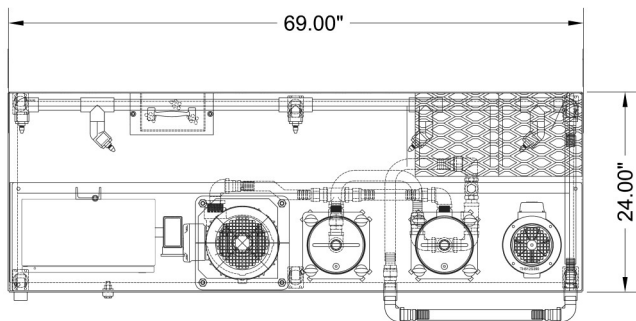

**COMPLETE  
METALWORKING  
SOLUTIONS**

(800) 991-4225  
www.ahbinc.com  
ISO Certified  
customerservice@ahbinc.com