

Coolant Clarification Systems

SludgeMasters Series- 70 GPM

Model: SMF-7030



**COMPLETE
METALWORKING
SOLUTIONS**

(800) 991-4225

www.ahbinc.com

ISO Certified

customerservice@ahbinc.com

Sludgemaster's Unique Approach To Coolant Management Will Extend Coolant Life By Preventing Contaminants From Accumulating Anywhere In The System. Sludgemasters Combines The Process Of Circulation, Filtration And Evacuation In A Continuous Coolant Management System That Has Few Moving Parts, No Media Replacement And Is Virtually Maintenance-Free. By Using The Unique Centrifugal-Action Of Lakos Separators, Solids Are Transferred Automatically Into A 55-Gallon Drum Or Hopper For Easy Disposal Or Resale As Scrap. All Of These Points Will Lead To Increased Production, Decreased Cost, And A Cleaner Working Environment.



Shown with optional Chiller for Temperature Control

Specifications

Tank Capacity	150 Gallons
Clean Coolant	30 Gallons
Flow Rate	70 GPM
System Pressures	40 PSI
Suction Size	2"
Discharge Size	1"
Filter Pump	Heavy Duty Vertical
Voltage	230 or 460 Three Phase
Dimensions	60" L x 36" W x 22" H
Clean Discharge	30 GPM Clean 40 GPM Dirty

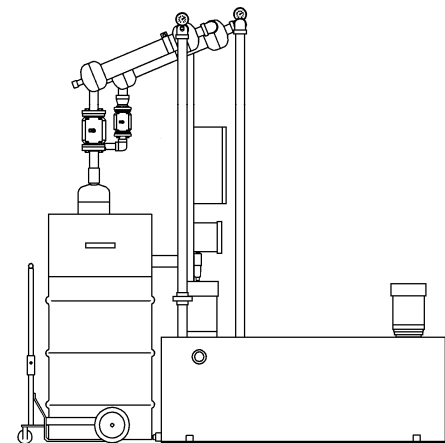
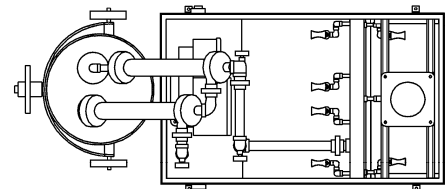

Shown with optional Clean Delivery Pump

