

Coolant Clarification Systems

SludgeMasters Series- 90 GPM

Model: SMF-9040



**COMPLETE
METALWORKING
SOLUTIONS**
(800) 991-4225
www.ahbinc.com
ISO Certified
customerservice@ahbinc.com

Sludgemaster's Unique Approach To Coolant Management Will Extend Coolant Life By Preventing Contaminants From Accumulating Anywhere In The System. Sludgemasters Combines The Process Of Circulation, Filtration And Evacuation In A Continuous Coolant Management System That Has Few Moving Parts, No Media Replacement And Is Virtually Maintenance-Free. By Using The Unique Centrifugal-Action Of Lakos Separators, Solids Are Transferred Automatically Into A 55-Gallon Drum Or Hopper For Easy Disposal Or Resale As Scrap. All Of These Points Will Lead To Increased Production, Decreased Cost, And A Cleaner Working Environment.



Shown with optional Chiller for Temperature Control

Specifications

Tank Capacity	255 Gallons
Clean Coolant	40 Gallons
Flow Rate	90 GPM
System Pressures	40 PSI
Suction Size	3"
Discharge Size	2"
Filter Pump	5 hp
Voltage	230 or 460 Three Phase
Dimensions	72" L x 48" W x 24" H
Clean Discharge	40 GPM Clean 60 GPM Dirty

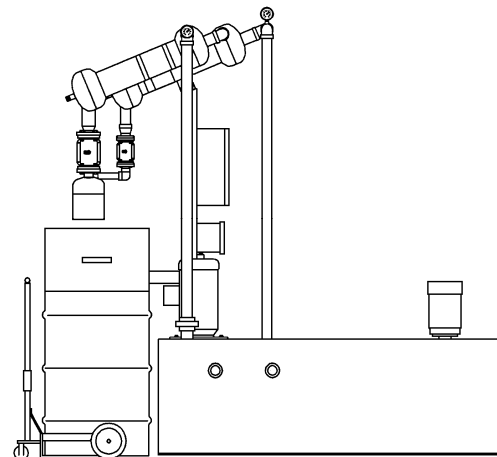
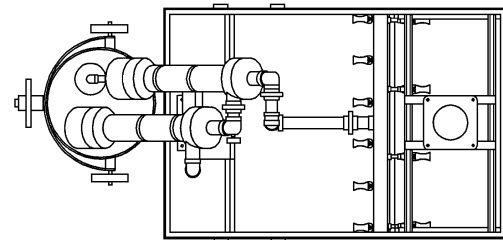

Shown with optional Clean Delivery Pump

