

# MistBuster® 2000 – Next Generation

<b>Model</b>	<b>MB2000</b>
<b>Airflow</b>	Variable to 1650 cfm @ .6" W.C.
<b>Cabinet</b>	16 gauge steel cabinet with powder coated chemical resistant baked enamel, available in ivory or gray textured finish
<b>Power Input</b>	115 Vac, 60 Hz, 1 ph, 4 amps 240 Vac, 60 Hz, 1 ph, 2 amps
<b>Efficiency</b>	Ultimate efficiency up to 99.6% on all submicron particles as measured by independent lab test in accordance with ASHRAE standard 52.2 at 1000 CFM.
<b>Filtration Stages</b>	1st Stage: 4" aluminum mesh impinger 2nd Stage: DuroClean (Long Life) Electronic Cell x 2 3rd Stage: MistBuster (High-Efficiency) Cell x 2 4th Stage: Optional MistBuster (High-Efficiency) Cell x 2 5th Stage: Optional HEPA filter 99.97% efficiency, ESF Filter, or Carbon Module
<b>Features</b>	Two self-regulating, dual voltage solid state power supply (standard) Patented water/oil coolant collector selector Backward curved, vibration-free, direct drive motorized impeller rated at 1950 cfm maximum Ten-foot power cord with molded plug
<b>Dimensions</b>	Cabinet: 26.00"L x 26.30"W x33.06"H
<b>Inlet Opening</b>	16" x 20.75"
<b>Weight</b>	203 lbs installed; 230 lbs shipping
<b>Accessories</b>	Machine Mount Stand   Pedestal Stand Ceiling Mount Kit   Wall Mount Kit Plenum   Diffuser   HEPA Postfilter ESF Postfilter   Carbon Module

Specifications subject to change without notice.



*DuroClean™ (Long Life) Electronic Cell*



*Patented coolant selector*

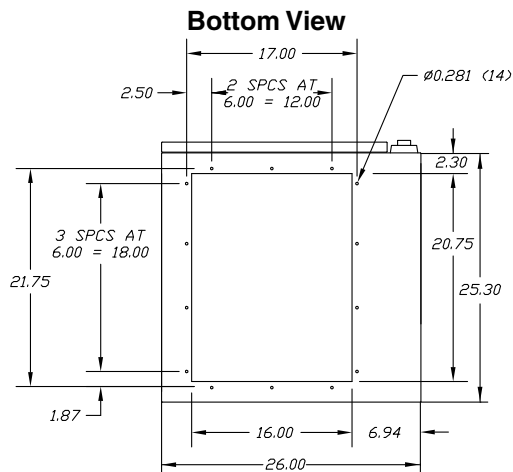
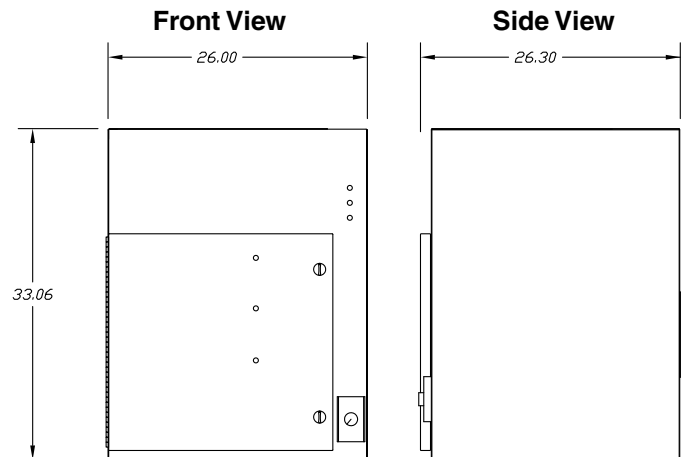

**COMPLETE METALWORKING SOLUTIONS**  
 (800) 991-4225 [www.ahbinc.com](http://www.ahbinc.com)  
 ISO Certified [customerservice@ahbinc.com](mailto:customerservice@ahbinc.com)



7140 Northland Drive North, Brooklyn Park, MN 55428-1520, USA  
**TOLL FREE: 800-991-4225 EMAIL: [customerservice@ahbinc.com](mailto:customerservice@ahbinc.com)**