

MistBuster® 500 – Next Generation

Model	MB500
Airflow	Variable to 500 cfm
Cabinet	16 gauge steel cabinet with powder coated chemical resistant baked enamel, available in ivory or gray textured finish
Power Input	115 Vac, 60 Hz, 1 ph, 2 amps 230 Vac, 60 Hz, 1 ph, 1 amp
Efficiency	Ultimate efficiency up to 97.8% on all submicron particles as measured by independent lab test in accordance with ASHRAE standard 52.2 at 500 CFM
Filtration Stages	1st Stage: 2" baffled inertial impinger 2nd Stage: 2" aluminum mesh impinger 3rd Stage: DuroClean (Long Life) Electronic Cell 4th Stage: Optional HEPA filter 99.97% efficiency, ESF Filter, or Carbon Module
Features	Self-regulating, dual voltage solid state power supply Patented water/oil coolant collector selector Patented design for long term high efficiency Backward curved, vibration-free, direct drive motorized impeller rated at 710 cfm Ten-foot power cord with molded plug Quick release connectors for fast, easy side panel access
Dimensions	Cabinet: 27.10 "L x 13.49 "W X 17.12"H
Inlet Opening	16.62" x 9.08"
Weight	65 lbs installed; 76 lbs shipping Capable of being shipped via UPS
Accessories	Machine Mount Stand Pedestal Stand Ceiling Mount Kit Wall Mount Kit Plenum Diffuser HEPA Postfilter ESF Postfilter Carbon Module Machine Tool Activated Control

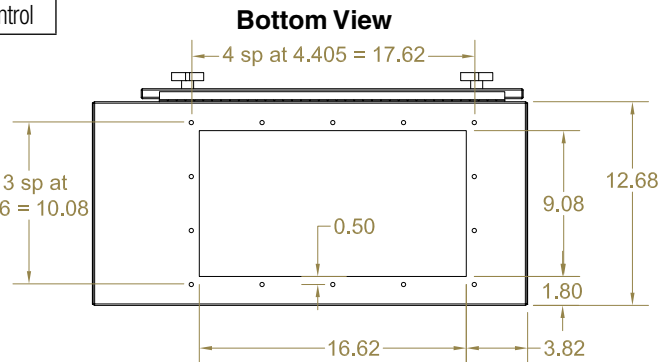

Specifications subject to change without notice.

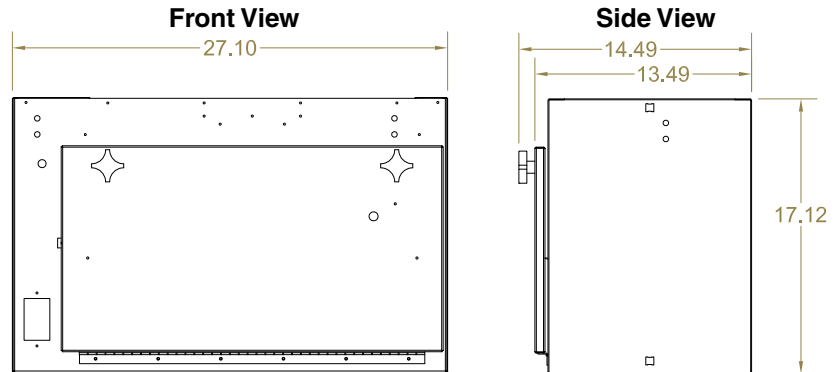

COMPLETE METALWORKING SOLUTIONS
 (800) 991-4225 www.ahbinc.com
 ISO Certified customerservice@ahbinc.com



7140 Northland Drive North, Brooklyn Park, MN 55428-1520, USA
TOLL FREE: 800-991-4225 EMAIL: customerservice@ahbinc.com