



COMPLETE  
METALWORKING  
SOLUTIONS

(800) 991-4225

[www.ahbinc.com](http://www.ahbinc.com)

ISO Certified

[customerservice@ahbinc.com](mailto:customerservice@ahbinc.com)

**Serv-O-Spray™** *Repeatable Precision*

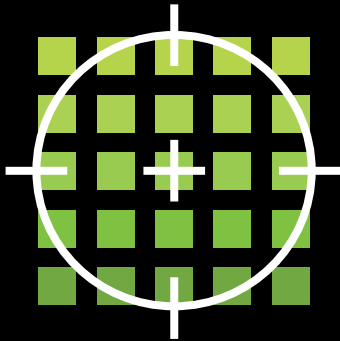



Serv-O-Spray™ delivers precise, repeatable shots of lubricant, and is ideal for any operation where controlled, intermittent fluid application is needed.

- Deliver a fixed amount of fluid with each and every shot
- Adjustable pumps deliver 0.003-0.100 mL per stroke
- Pumps are air actuated
- Easy adjustability and control over spray consistency
- Neat, clean fluid delivery - Eliminate the mess of flood coolants

## How It works:

The Serv-O-Spray™ pump is ready to dispense a shot of fluid.

**Note:** The system is full of fluid (green) all the way to the nozzle tip.

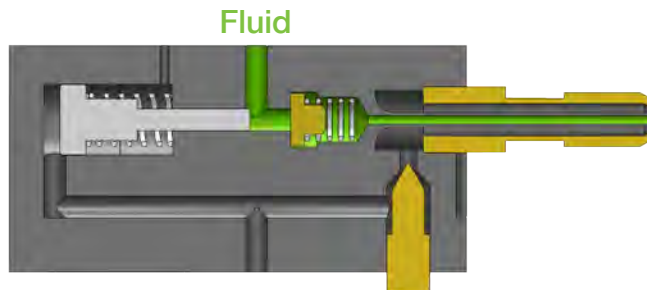

When an air signal (blue) is applied, the pump piston strokes, immediately pushing a fixed quantity of fluid out the nozzle tip. Simultaneously, an adjustable amount of air surrounds the fluid to break it up and propel it to the point of application.

The air will continue to flow out the nozzle tip until the air signal is released, which also allows the pump to refill, ready to dispense another shot of fluid.

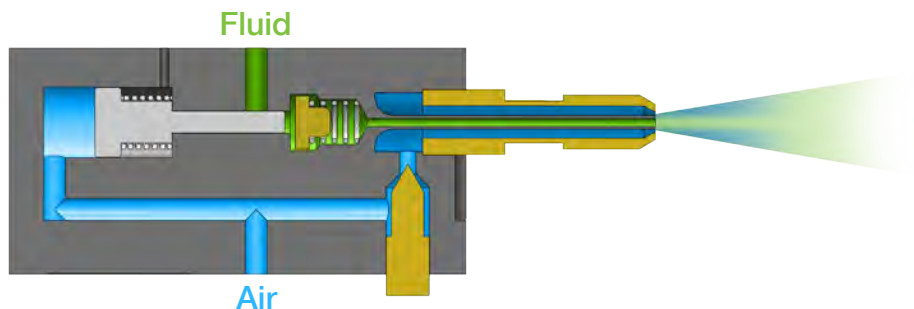

# Serv-O-Spray™ Features

## Intermittent Fluid Output

Actuating your Serv-O-Spray™ is easy. Every time a compressed air signal is supplied from an actuation valve, the pump will deliver one quick shot of fluid out the nozzle tip along with a controlled amount of air. Air continues to flow from the nozzle tip until the air actuation valve is closed. Each time air is supplied, the pump immediately fires another shot. The pumps can be cycled as often as needed, up to 150 times per minute.



## Separate Fluid & Air

Our coaxial nozzles keep the air and fluid separate right up to the spray tip. This unique configuration can deliver fluid over long distances without the need for excessive amounts of air. Each time the pump strokes, a metered amount of fluid sprays out the nozzle tip, and is immediately atomized by the outer jacket of air. This feature delivers a balanced spray pattern at the point of application.

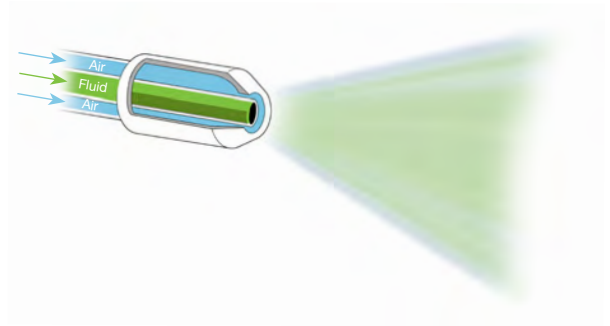

## Dial In The “Sweet Spot”

The Serv-O-Spray™ was designed for precise control over the fluid application with separate fluid and air volume adjustments. This means that finding the sweet spot for your application is a breeze and once it's set, the Serv-O-Spray™ will deliver the same amount of fluid again and again.



Easily adjust pump stroke and air flow for the perfect spray.

## Modular Design

The stackable, modular design of the Serv-O-Spray™ pumps make it easy to build a system for almost any application. Pumps can be actuated independently or in groups to spray multiple points with a single control valve.



## Serv-O-Spray™ Applications

## Repeatable Precision

The precise, repeatable fluid delivery of the Serv-O-Spray™ makes it the ideal choice for many fluid application needs!

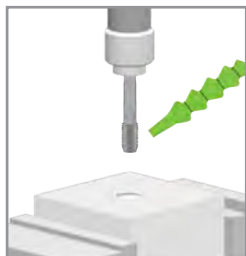

### Minimum Quantity Lubrication (MQL) For Short-Cycle Machining

The Serv-O-Spray™ system is great for applying a single shot of lubricant to smaller drills and taps, especially in automated operations. For larger tools that require more lubricant than a single shot can deliver, the pump can be pulsed multiple times per machining cycle.

### Why Use MQL?

- Increases Production Speed
- Eliminates Flood Coolant Mess
- Improves Tool Life
- Increases Chip Value
- Improves Surface Finish



Machining with flood coolant

### Why Serv-O-Spray™ For MQL?

With Minimum Quantity Lubrication (MQL), it's important to apply the proper amount of lubricant for each machining operation. The design of the Unist Serv-O-Spray™ assures consistent fluid delivery with an adjustable positive displacement pump and a precision air metering adjustment. The correct quantity of lubricant and air can easily be "dialed in" to achieve the perfect spray for each application.



Machining with MQL



*Coolube® is a  
USDA certified  
biobased product*

### Serv-O-Spray™ & Coolube®

Maximize the benefits of MQL by filling your Serv-O-Spray™ reservoir with Unist Coolube®. Coolube® is a 100% natural biodegradable lubricant derived from renewable vegetable products. This environmentally friendly cutting oil is completely safe for operators and when applied properly, Coolube® is completely consumed in the machining process, eliminating the mess of traditional flood coolant. As an added benefit, when a Serv-O-Spray™ is used exclusively with Coolube®, Unist guarantees the pumps forever!



## Punching

A Serv-O-Spray™ system works great for applying lubricant to punches. Use with any type of punching operation including turret presses. Improves finishes and increases punch life dramatically.

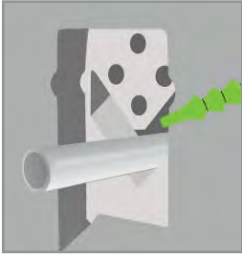

## Cut Off Knives And Shears

Apply a small amount of Coolube® to knives and shears to produce cleaner cuts and increase tool life.

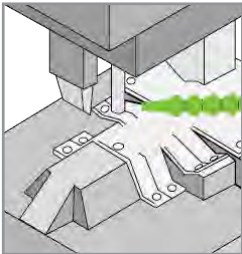

## Die Lubrication

Choose a Serv-O-Spray™ system when only a small amount of in-die lubrication is needed. This system is ideal for lubricating punches, forming dies, or in-die taps with single or multiple outlets. Individual nozzles on multiple output systems can be controlled independent of each other.



## Assembly Operations

Need to lube seals or other components prior to assembly? Use a Serv-O-Spray™ system with standard or custom designed nozzles for any lubrication requirement.

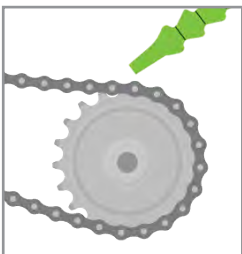

## Wearpoint And Chain Lubrication

Lubricating cams, bearings, chains, or other wearpoints can be a simple process with the Serv-O-Spray™ system. Replacing messy greases with precisely applied oil is an easy way to improve machine reliability and decrease down time.



The Serv-O-Spray's™ modular design can be configured for almost any application!



## Free 30 Day On-Site Trial

Experience the benefits of the Serv-O-Spray™ in your shop free for 30 days.

**Contact Unist today for details.**

800.991.4225  
U.S. & Canada



Testing a Serv-O-Spray™

## Unist Quality: Triple-Tested Performance

At Unist, the quality of our products is extremely important to all of us. That's why each Serv-O-Spray™ undergoes an extensive 3-step testing process. We begin by fluid testing each metering pump individually to ensure proper output and function. Following that, we test the entire pump assembly before verifying the operation of the finished Serv-O-Spray™ assembly for a third time with Unist Coolube® lubricant.

Need assistance configuring your system? We can help!

# Typical Serv-O-Spray™ System

**A. Air Filter**

Standard on every system

**B. Actuation Valve**

Options include solenoid valve (shown), air pilot valve, manual valve, or foot valve

**C. Positive Displacement Metering Pump**

Precise and reliable with outputs of up to 0.03 mL/stroke or 0.10 mL/stroke

**D. Nozzle Air Flow Adjustment**

Dial in the perfect spray pattern

**E. Pump Stroke Adjustment**

Dial in the perfect amount of lubricant per shot

**F. 16 Ounce (473 mL) Fluid Reservoir**

Additional sizes and styles available

**G. Rugged Steel Enclosure**

Removable cover for easy adjustment or maintenance (optional keyed lock)

## Semi-Automatic Lubrication

Serv-O-Spray™ features semi-automatic action: one signal, one shot of lubricant



For more info:  
[unist.com/serv-o-spray](http://unist.com/serv-o-spray)

## Configuration Options

### Multiple Outputs

Operate up to 16 pumps for 16 individual outputs. Outputs can be configured to operate independently or in multiples. Various sized enclosures are available depending on the number of pumps.



1-3 Outlet Enclosure



4-6 Outlet Enclosure



7-11 Outlet Enclosure



12-16 Outlet Enclosure

### Air Valve Options

Control Serv-O-Spray™ operation with the following valve options:

- **Solenoid Valve**

For actuation using an electrical signal from the machine



(Available in 24, 110, 220, 440 VAC and 12 or 24 VDC)

- **Multiple Solenoid Valves**

For actuation of multiple outputs using electrical signals



- **Air Pilot Valve**

For use with a low flow air signal



- **Foot Valve**

For hands-free manual operation



### Pump Options

Choose the appropriate pump output and type for each application.

- **Standard 1-Drop Pump**  
(0.03 mL per stroke)



- **Standard 3-Drop Pump**  
(0.10 mL per stroke)



- **Multi-Viscosity 1-Drop Pump**  
(0.045 mL per stroke)



- **Multi-Viscosity 2-Drop Pump**  
(0.10 mL per stroke)



The fluid viscosity will determine the type of Unist pump required.

For Coolube® and other fluids between 50 SUS and 1,000 SUS, choose the standard 1 or 3-Drop pump.

For fluids less than 50 SUS, choose the Multi-Viscosity (MV) 1 or 2-Drop pump.

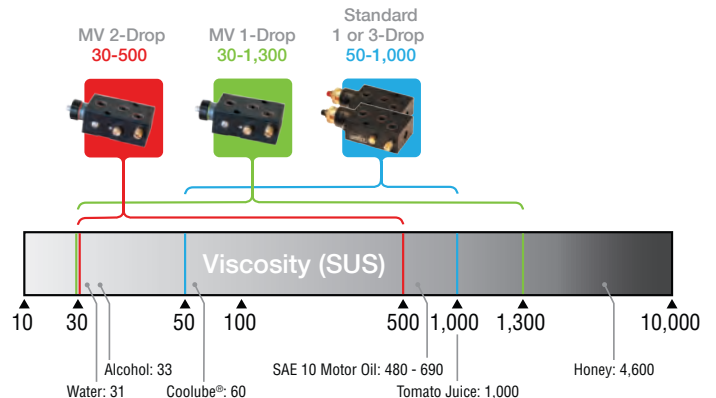





## Reservoir Options

A wide variety of fluid reservoirs are available.



10 oz. (296 mL)  
Nylon



16 oz. (473 mL)  
Polyethylene



32 oz. (946 mL)  
Polyethylene



64 oz. (1893 mL)  
Polyethylene  
(Available with a low level switch)



Air trap for use with a pressurized fluid supply



## Mounting Options

Magnetic mounts are available for both nozzles and system enclosures. The articulated arm mount makes nozzle positioning easy.



Nozzle Mounting Magnets



Enclosure Mounting Magnets



Articulating Arm Mount With Magnetic Base



## Enclosure Lock Option

Upgrade from the standard thumb latch to a keyed lock and prevent tampering.



## Nozzle Extension Options

Two types of hose/tubing are available for connecting nozzles to a Serv-O-Spray™ system. Standard length is 5 feet (1.5 m). Other lengths are available upon request.

- Coaxial Polyurethane



- Coaxial Braided Stainless Steel



## Nozzle Options

Unist has a wide variety of MQL nozzle types to fit each specific application.

- A. Semi-Rigid Copper Nozzle
- B. Flexible Plastic Nozzle
- C. Flexible Steel Nozzle
- D. Rigid Stainless Steel Nozzle



**Notes**

## Notes



COMPLETE  
METALWORKING  
SOLUTIONS

(800) 991-4225

[www.ahbinc.com](http://www.ahbinc.com)

ISO Certified

[customerservice@ahbinc.com](mailto:customerservice@ahbinc.com)

