

# Installation, Operation and Maintenance Manual

## Light Commercial Reverse Osmosis Systems

Models: LC-2514-01-1, LC-2521-01-1



LC-2521-01-1

## **THANK YOU**

Congratulations on your purchase of this Watts® LC-25 light commercial reverse osmosis system. You've made an excellent choice for delivering high-quality water while reducing contaminants that can impact your equipment and water quality. This system has been designed for reliable performance and built using premium components to ensure efficiency and durability. With user-friendly operation, corrosion-resistant materials, and a service-friendly design, your system is engineered for long-term, hassle-free maintenance.

Thank You!

The Watts Team

Reverse osmosis filtration offers a wide range of benefits, including reducing dissolved solids, reducing scale buildup in critical equipment, and providing clean, quality water. By protecting your plumbing and appliances from mineral deposits and other impurities, this system helps minimize maintenance costs and downtime while ensuring consistent water quality for your commercial applications.

## ⚠ WARNING



**Please read carefully before proceeding with installation. Your failure to follow any attached instructions or operating parameters may lead to the product's failure.**

**Keep this Manual for future reference.**



## ⚠ WARNING

If you are unsure about installing your Watts reverse osmosis system contact a Watts representative or consult a professional water treatment dealer or plumber.

You are required to thoroughly read all installation instructions and product safety information before beginning the installation of this product. FAILURE TO COMPLY WITH PROPER INSTALLATION AND MAINTENANCE INSTRUCTIONS COULD RESULT IN PRODUCT FAILURE WHICH CAN CAUSE PROPERTY DAMAGE, PERSONAL INJURY AND/OR DEATH. Watts is not responsible for damages resulting from improper installation and/or maintenance. Local building or plumbing codes may require modifications to the information provided. You are required to consult the local building and plumbing codes prior to installation. If this information is not consistent with local building or plumbing codes, the local codes should be followed.

Save manual for future reference.

Refer to the enclosed for operating parameters to ensure proper use with your water supply.

- As with all plumbing projects, it is recommended that a trained professional water treatment dealer or contractor install the water treatment system. Please follow all local plumbing codes for installing this water treatment system.
- Inspect the water treatment system for carrier shortage or shipping damage before beginning installation. Replace any damaged component immediately, before beginning installation.
- Use caution when installing soldered metal piping near the water treatment system. Heat can adversely affect the system's components.
- Use only lead-free solder and flux for sweat-solder connections, as required by state, province and federal codes.
- Handle all components of the system with care. Do not drop, drag or turn components upside down.
- Be sure the floor under the system is clean, level and strong enough to support the system while in operation.
- Install the system in a protected area.
- Do not attempt to treat water over 100°F (38°C) or under 34°F (1°C) with the system.
- Do not install in direct sunlight as overheating of electronics may occur and ultraviolet rays from the sun may cause damage. Exterior protection equipment is required for outdoor operation. Failure to follow outdoor installation requirements will void the warranty. Please consult Watts technicians before installing the system outside.
- Operating ambient temperature: 34° to 120°F (1° to 49°C).
- Operating water pressure range : 30 to 120 psi (2.1 bar to 8.3 bar).
- All plumbing connections to the system should be made using industry accepted best practices. Plumbing tape or paste may be used on metal inlet and outlet plumbing connections. Do not use paste type pipe thread sealants on the system's plastic plumbing connections.
- All electrical connections must be completed according to local codes.
- The power outlet must be grounded.

- For installations where plastic plumbing is used, install an appropriate grounding strap across the inlet and outlet piping of the building's metal plumbing to ensure that a proper ground is maintained.
- Always turn off the unit, shut off the feed water, and disconnect the electrical power when working on the unit.
- Observe drain line requirements.
- Never start the pump with the reject valve closed.
- Support the full weight of the plumbing system with pipe hangers or other means.
- Do not allow this water treatment system to freeze. Damage from freezing will void this water treatment system's warranty.
- Periodic cleaning and maintenance is required for system to function properly.
- Observe all warnings that appear in this manual.

## ⚠ WARNING

- Do not under any circumstance remove any caution, warning, or other descriptive labels from the system.
- Always turn off the unit, shut off the feedwater, relieve pressure, and disconnect the electrical power before working on the unit.
- Do not close the concentrate valve completely.
- Do not operate the system with insufficient feed flow. Never allow the pump to run dry.
- Do not shut down the system for extended periods. It is best to run the system as much as possible on a continuous basis.
- Recycling concentrate water will increase the dissolved solids in the water being processed by the membranes thus affecting the permeate quality. Excessive recycling may cause premature fouling or scaling of the membrane elements.
- The ph of the reverse osmosis permeate water will typically be 1-2 points lower than the feed water ph. A low ph can be very aggressive to some plumbing materials such as copper piping.
- Any restrictions or blockage in the drain line can cause backpressure, which will increase the system's operating pressure. This can result in damage to the system's membrane and components.

## How To Use This Manual

This installation manual is designed to guide the installer through the process of installing and starting up this light commercial reverse osmosis system.

This manual is a reference and will not include every system installation situation. The person installing this equipment should have:

- Training on the control panel with all control parameters.
- Knowledge of reverse osmosis systems and how to determine proper control settings.
- Adequate plumbing skills.

## ⚠ WARNING

**Do not use with water that is microbiologically unsafe or of unknown quality without adequate disinfection before or after the system.**

# Contents

How To Use This Manual .....	3
I. Introduction .....	4
A. Reverse Osmosis Overview.....	4
B. Specifications*.....	5
C. Operating Limits**.....	5
D. Pretreatment.....	5
II. Controls, Indicators, and Components.....	6
III. Operation.....	7
A. Installation.....	7
B. Plumbing Connections.....	7
C. Electrical.....	7
D. Startup .....	7
E. RO Shut-down procedure .....	7
F. Preparing Unit for Storage .....	7
G. Preparing Unit for Shipment.....	8
H. Replacing Filter Cartridges.....	8
IV. Electrical .....	8
A. LC-25 Series Wiring Diagram.....	8
B. LC-25 Process Flow Diagram.....	9
C. Operation and Maintenance Log.....	10
D. Troubleshooting .....	11
V. Replacement Parts List.....	12
VI. Membrane Element Specifications .....	13
VII. Membrane Installation and Replacement.....	14
VIII. Appendix .....	15
Temperature Correction Factors .....	15

# I. Introduction

The separation of dissolved solids and water using RO membranes is a pressure driven temperature dependent process. The membrane material is designed to be as permeable to water as possible, while maintaining the ability to reject dissolved solids.

The main system design parameters require the following:

- Internal flows across the membrane surface must be high enough to prevent the accumulation of fine suspended solids, fouling, and scaling, which could reduce membrane efficiency and damage the membrane.
- The concentration of each dissolved ionic species must not exceed the limits of solubility anywhere in the system.
- Pre-treatment must be sufficient to eliminate chemicals that would attack the membrane materials, particulates, organics, and chemicals that could attack or degrade the membrane material.

## A. Reverse Osmosis Overview

Reverse osmosis systems utilize semipermeable membrane elements to separate the feed water into two streams. The pressurized feed water is separated into permeate (product) water and concentrate (reject) water. The impurities contained in the feed water are carried to the drain by the reject water. It is critical to maintain adequate reject flow in order to prevent membrane scaling and/or fouling.

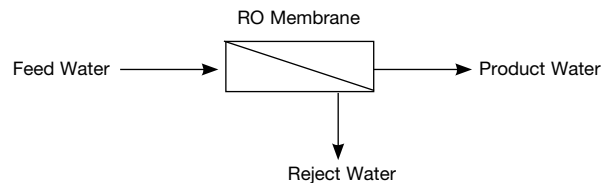

### NOTICE

Changes in operating variables are beyond the control of Watts. The end user is responsible for the safe operation of this equipment. The suitability of the product water for any specific application is the responsibility of the end user.

Successful long-term performance of an RO system depends on proper operation and maintenance of the system. This includes the initial system startup and operational startups and shutdowns. Prevention of fouling or scaling of the membranes is not only a matter of system design, but also a matter of proper operation. Record keeping and data normalization are required in order to know the actual system performance and to enable corrective measures when necessary. Complete and accurate records are also required in case of a system performance warranty claim.

Changes in the operating parameters of an RO system can be caused by changes in the feed water or can be a sign of trouble. Maintaining an operation and maintenance log is crucial in diagnosing and preventing system problems. For your reference, a typical log sheet is included in this manual.

## B. Specifications\*

Call customer service if you need assistance with technical details.

	LC-2514-01-1	LC-2521-01-1
Order code	68111200	68111201
Maximum Productivity (gallons per day)	200	300
Quality (average membrane rejection)	98.5%	
Recovery (user adjustable)	40%	50%
Membrane Size	2.5" x 14"	2.5" x 21"
Number Of Membranes	1	1
Filters (One 5 micron sediment and two 10 micron carbon filters)	10"	
Feed Water Connection	3/8" tubing	
Product Water Connection (tubing ID)	3/8" tubing	
Reject Water Connection (tubing ID)	3/8" tubing	
Permeate Water (maximum)	0.14 gpm	0.21 gpm
Minimum Concentrate Flow	0.21 gpm	
Feed Water Pressure (minimum)	30 psi	
Electrical Requirement	110V 1.0A	
Dimensions W x D x H (approximate inches)	9 x 20 x 19	9 x 27 x 19
Shipping Weight (estimated pounds)	42	50

### NOTICE

- Maximum production based on a feed water of 77°F, SDI < 1, 1000 ppm TDS, and pH 7. Individual membrane productivity may vary (± 15%). May be operated on other feed waters with reduced capacity.
- Percent rejection is based on membrane manufacturer's specifications; overall system percent rejection may be less.

## C. Operating Limits\*\*

PARAMETER	MAX	MIN
Design Temperature	77°F	
Feed Water Temperature†	85°F	40°F
Ambient Temperature	120°F	40°F†
Feed Pressure	85 psi	30 psi
Operating Pressure††	120 psi	80 psi
Turbidity	1 NTU	
SDI Rating	<3	
Free Chlorine	0 ppm	
TDS†	up to 1000 ppm	
Hardness	1 gpg	
pH (continuous)	11	2

† Low temperatures and feedwater quality, such as high TDS levels will significantly affect the systems production capabilities and performance. Computer projections must be run for individual applications which do not meet or exceed minimum and maximum operating limits for such conditions.

††The minimum inlet water pressure should be at least 30 psi. The system's minimum operating pressure is 80 psi, but the optimum operating pressure is 100 psi.

\* Product flow and recovery rates are based on feedwater conditions of 550 ppm TDS at 77F and 60 psi. Treatment ability of the RO system is dependent on feed water quality. Higher TDS and/or lower temperatures will reduce product flow. Performance projections should be run for each installation. If any of the feed water parameters are not within the limits given, consult your local dealer or distributor for assistance.

\*\*System pressure is variable due to water conditions. Permeate flow will increase at a higher temperature and will decrease at a lower temperature.

### CAUTION

**Higher TDS and/or lower temperatures will reduce the system's production.**

### WARNING

**Do not exceed the recommended permeate flow.**

### NOTICE

- Do not operate at a pressure exceeding 120 psi. The operating pressure can be increased on the face of the booster pump by turning the hex screw clockwise
- The tank pressure switch will shut the system off automatically when the bladder tank is full
- Any chlorine exposure will damage the membrane permanently.

## D. Pretreatment

The RO feed water must be pretreated in order to prevent membrane damage and/or fouling. Proper pretreatment is essential for reliable operation of any RO system. As light commercial units, LC-25 series products are bundled with pre-installed 5 micron sediment filter and 10 micron carbon block, which will suffice the pre-treatment requirement for most of municipal water. However, a set of thorough pre-treatment is always recommended. Since water quality application differs by location, it is important to contact your equipment dealer or service provider regarding specific settings appropriate to operating the reverse osmosis system consistent with the temperature and quality of your feed water source.

Below are the most common forms of pretreatment for your reference.

**Media Filter** - Used to reduce large suspended solids (sediment) from the feed water. Backwashing the media removes the trapped particles. Backwash can be initiated by time or differential pressure. A backwash interlock is necessary to ensure proper system operation and prevent disruptions.

**Water Softener** - Used to remove calcium and magnesium from the feed water in order to prevent hardness scaling. The potential for hardness scaling is predicted by the Langelier Saturation Index (LSI). The LSI should be zero or negative throughout the unit unless approved antiscalants are used. Softening is the preferred method of controlling hardness scale. Under certain conditions, the softener can be eliminated with proper antiscalant dosing. Consult a Watts technician for accurate sizing and dosage projection.

**Carbon Filter** - Used to reduce chlorine and organics from the feed water. Free chlorine will cause rapid irreversible damage to the membranes. Organics (TOC) can lead to fouling, reducing system efficiency and membrane lifespan. LC-25 products are equipped with two 10-micron carbon filters for pre and post treatment.

**The residual free chlorine present in most municipal water supplies will damage the thin film composite structure of the membranes used in this unit. Carbon filtration or sodium bisulfite injection should be used to completely remove the free chlorine residual.**

**Chemical Injection** - Typically used to feed antiscalant, coagulant, or bisulfite into the feed water or to adjust the feed water pH.

**Prefilter Cartridge** - Used to trap smaller suspended solids and any particles that may be generated by the other pretreatment. The cartridge(s) should be replaced when the pressure drop across the housing increases 5 - 10 psig over the clean cartridge pressure drop. The effect of suspended solids is measured by the silt density index (SDI) test. An SDI of five (5) or less is specified by most membrane manufacturers and three (3) or less is recommended. LC-25 products are equipped with a 5-micron sediment filter.

**Iron & Manganese** - These foulants should be removed. Special media filters and/or chemical treatment is commonly used.

**pH** - The pH is often lowered to reduce the scaling potential. If the feed water has zero hardness, the pH can be raised to eliminate CO<sub>2</sub>.

**Silica**: Reported on the analysis as SiO<sub>2</sub>. Silica forms a coating on membrane surfaces when the concentration exceeds its solubility. Additionally, the solubility is highly pH and temperature dependent. Silica fouling can be prevented with chemical injection and/or reduction in recovery.

## II. Controls, Indicators, and Components

The Dotted lines are items that are not visible in the image. Refer to page 12 for a detailed view of these components.

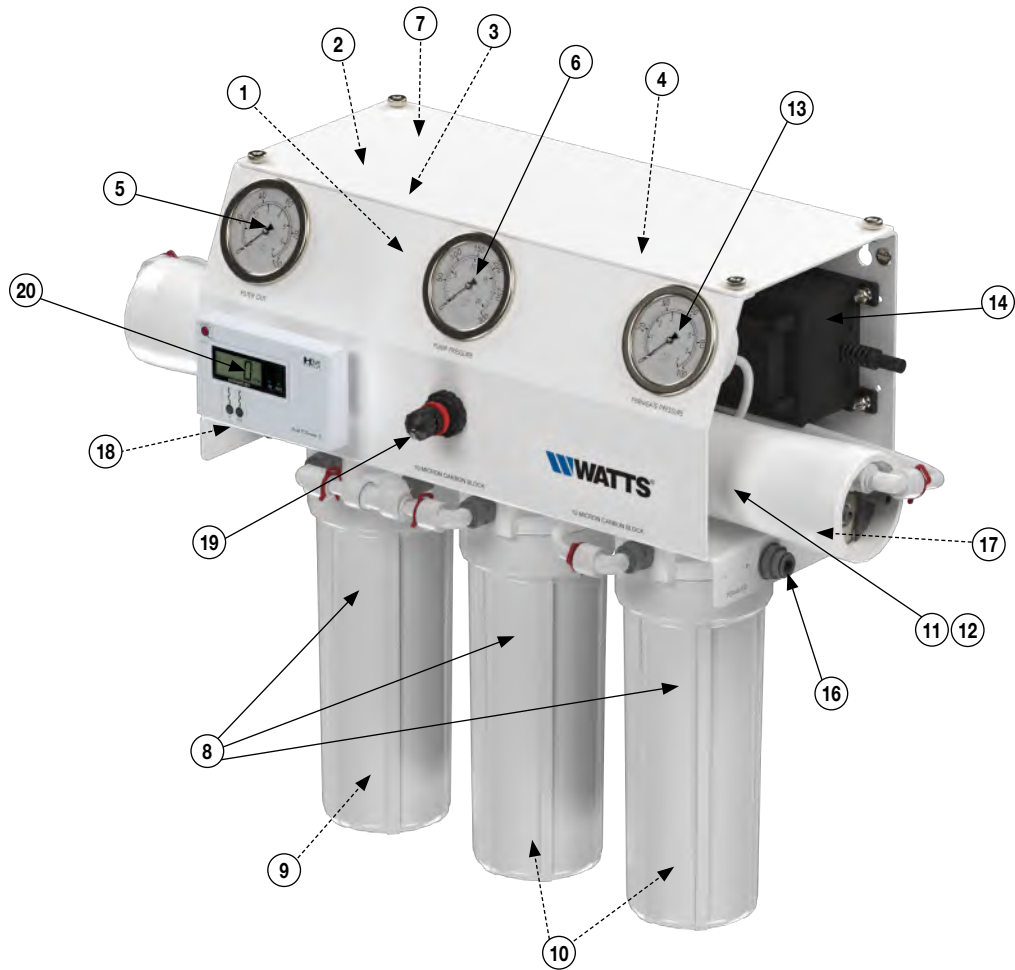

Figure 1

ITEM NO.	PART NAME	DESCRIPTION
1*	Flow Restrictor	Valve on concentrate line to regulate system recovery.
2*	Check Valve	Prevent backflow to RO unit
3*	Pressure switch	Turns off system when product pressure reaches 40 psi, and turns system on at 20 psi.
4*	Feed Water Inlet Isolation Valve	System inlet valve. Opens when system is in operation, closes when product tank is full or system is in non-operational mode.
5	Post-filter pressure gauge	Indicate pre-pump feed pressure
6	Pump Discharge Pressure Gauge	Indicates the membrane feed pressure
7*	RO Feed Pump	Pressurizes the RO feed water
8	Pre-Filter Housing	Housings for 5 micron sediment and 10 micron carbon filters
9	Sediment Filter	Filters out suspended solids larger than 5 microns in the feed water to the system
10	Carbon Block	Filters out free chlorine, improves taste and odor
11	Membrane Housing	Contains the RO membrane
12	RO Membrane	Reverse osmosis membrane filters out dissolved solids (TDS) to produce permeate.
13	Permeate pressure gauge	Indicate permeate product pressure
14	Transformer	Transforms incoming voltage to 24VAC to power R.O. motor/pump and system
15	Feed Connection Port	3/8" Quick Connect. Connect the feed source to this line
16	Permeate Connection Port	3/8" Quick Connect. Connect this line to end use.
17	Concentrate Connection Port	3/8" Quick Connect. Connect this to line drain.
18	Tank Connection Port	3/8" Quick Connect. Connect this line to the product water bladder tank.
19	Blending Valve	Adjust bypass/blending Flow based on water quality needs
20	TDS Monitor	Measure the TDS of permeate water

\* Items not visible are under the product cover.

## III. Operation

### A. Installation

1. Proper pretreatment must be determined and installed prior to the RO system.
2. The water supply and pretreatment equipment should be sufficient to provide a minimum of 30-psig at the maximum feed flow. The pressure shall not exceed 85 psi.
3. An electrical disconnect switch located within 10 feet of the unit is recommended.
4. Responsibility for meeting local electrical and plumbing codes lies with the owner / operator.
5. Install indoors in an area protected from freezing and direct sunlight. Space allowances for the removal of the membranes from the pressure vessels should be provided. Leave 6 inches of space below the filter housings for ease of maintenance.
6. Verify that a prefilter cartridge and carbon filter cartridges are installed in the housings. (See Figure #1, Item 9 and 10).

### B. Plumbing Connections

**Note: It is the responsibility of the end user to ensure that the installation is done according to local codes and regulations.**

1. Connect the  $\frac{3}{8}$ " tube fitting to an incoming water source. The minimum inlet water pressure should be at least 30 psi. The system's minimum operating pressure is 80 psi, but the optimum operating pressure is 100 psi.
2. Temporarily connect the permeate water outlet to a drain. The product water line should never be restricted. Membrane and/or system damage may occur if the product line is blocked. An inline check valve is located at the product line to prevent the backflow.
3. This system has been factory wired and preset with a pressure switch at 20-40 psi, which is only to be used with a pressurized bladder tank. When the system is used with a bladder tank, connect a  $\frac{3}{8}$ " tubing line to the "TANK" port on the back of the systems. If using an atmospheric storage tank, a float switch will be required to turn the system on and off.
4. Connect the concentrate  $\frac{3}{8}$ " tubing (waste) line to drain. This system has been designed with an auto-flush restrictor. This restrictor automatically flushes the reverse osmosis system for 30 seconds every time it starts up and once every hour when the system is producing water.

### C. Electrical

Watts LC-25 series systems come pre-wired, ready to plug and play. LC-25 Series systems are available in 110/60HZ/1PH.

It is best that the LC-25 Series system be wired to a dedicated electrical circuit. Ensure that the electrical circuit supplying the system is compatible with the requirements of the specific LC-25 Series model you are installing.

### D. Startup

1. Verify that the pretreatment equipment (besides the pre-installed sediment filter and carbon filters) is installed and working properly. Verify that no free chlorine is present in the feed water.
2. Direct the permeate water to drain during startup.
3. Close the blending valve located at the front of the cover (Figure #1, item 19).
4. Feed the  $\frac{3}{8}$ " QC inlet with source water at 40-60 psi.
5. Plug system into electrical outlet.
6. Run system while permeate and concentrate lines feed to the drain for 20-30 minutes to flush out preservative and any trapped air (Purge).

7. After 20-30 minutes, shut down the system and re-direct the permeate line back to final use location (i.e. faucet). Dispose of the product water until the conductivity of the product water reaches your desired level. Refer to the TDS meter on the system to monitor the product water quality. A minimum quality of 96% NaCl rejection is recommended.

#### NOTICE

If blending is desired, slowly open the blending valve while closely monitoring the TDS value from the TDS monitor and the flow rates until the desired target is reached.

8. Your start up is now complete. Make sure that the system pressures and flows are matching up with that of your specific system model, located on the System Information (pg. 4) of this manual. Record the readings daily for a full week, then record the readings weekly. This will assist you to determine when component maintenance and/or replacement is necessary.

### E. RO Shut-down procedure

1. Unplug the system power cord from the wall.
2. Turn off feed supply water from system
3. Purge the system. See Section D - startup
4. If the reverse osmosis unit is to be shut down for an extended period of time, a membrane preservative should be used to preserve the membranes.
5. When the unit is ready to restart please follow the initial startup procedures. The permeate line should be diverted to drain for 30 minutes.

### F. Preparing Unit for Storage

If the system is to be shut down for an extended period, a membrane preservative should be used to preserve the membranes.

#### NOTICE

Prior to storing your system, the system should be cleaned with membrane cleaners, flushed with permeate water and preservative solution for membranes to protect it from biological attack.

#### NOTICE

The pressure vessels and plumbing lines of the system must be completely drained or filled with 20-40% polyglycol mix (to prevent freezing). Any water remaining in the plumbing of a system may freeze, causing serious damage.

1. Completely immerse the elements in the membrane housings using 2% preservative solution. For cold weather/winter storage add 20 - 40% by weight Polyglycol to the 2% preservative solution. Add Polyglycol AFTER the 2% M -100 solution has been mixed.
2. Separate the preservative solution from the air outside by closing all valves. Any contact with oxygen will oxidize the preservative solution.
3. Check the pH once a week. When the pH becomes 3 or lower, change the preservation solution.
4. Repeat this process at least once a month.

## III. Operation (continued)

### G. Preparing Unit for Shipment

1. Disconnect the inlet, concentrate, and permeate plumbing.
2. Drain all water from the pre-filter cartridge housings by unscrewing the housings, removing the pre-filter cartridges, and drain the water from the housings.
3. Disconnect the tubing from the connectors on the permeate and concentrate inlets and outlets.
4. Fully open the concentrate valve.
5. Allow the system to drain for a minimum of eight hours or until the opened ports quit dripping.
6. After draining is complete, reconnect all of the plumbing.

### H. Replacing Filter Cartridges

The reverse osmosis unit uses sediment filter cartridge and carbon block that need to be replaced frequently.

1. Turn off and unplug reverse osmosis unit.
2. Turn off water supply to system.
3. Drain the product water tank. Make sure all pressure gauges read 0.
4. With a filter wrench, remove filter housing bottom.
5. Remove and discard the old filter cartridges.
6. Install new filter cartridges.
7. Re-assemble the filter housing.
8. Plug unit back in and turn on water supply to system inlet.
9. Turn on the RO unit and inspect filter housing for leaks.

## IV. Electrical

### A. LC-25 Series Wiring Diagram

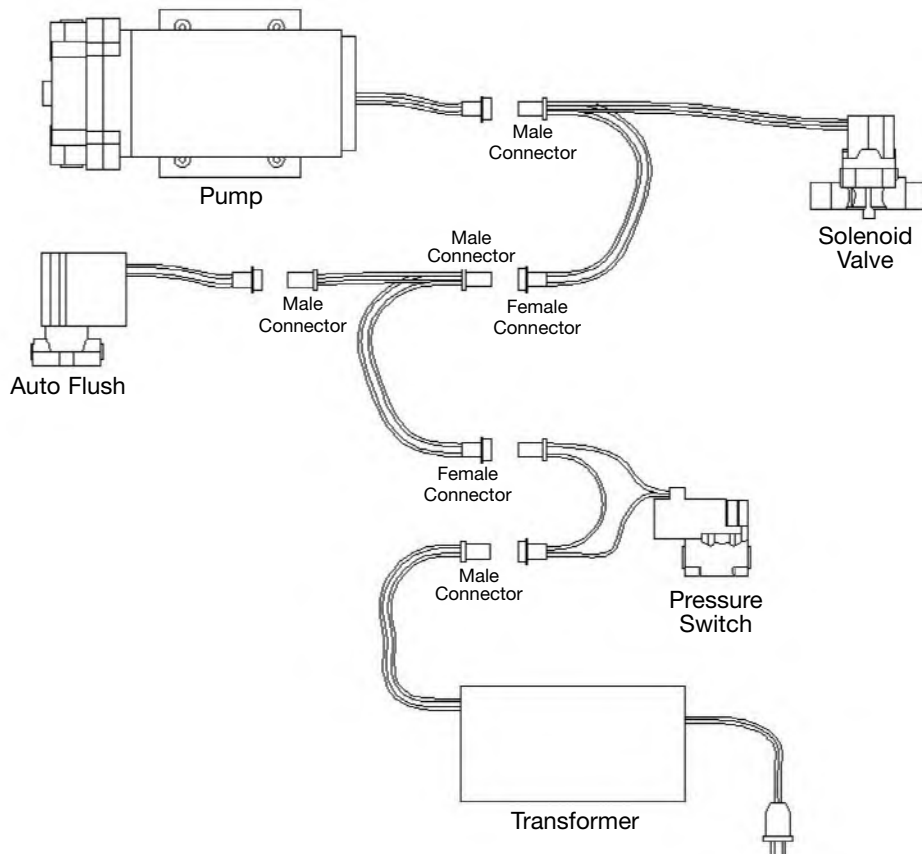

# B. LC-25 Process Flow Diagram

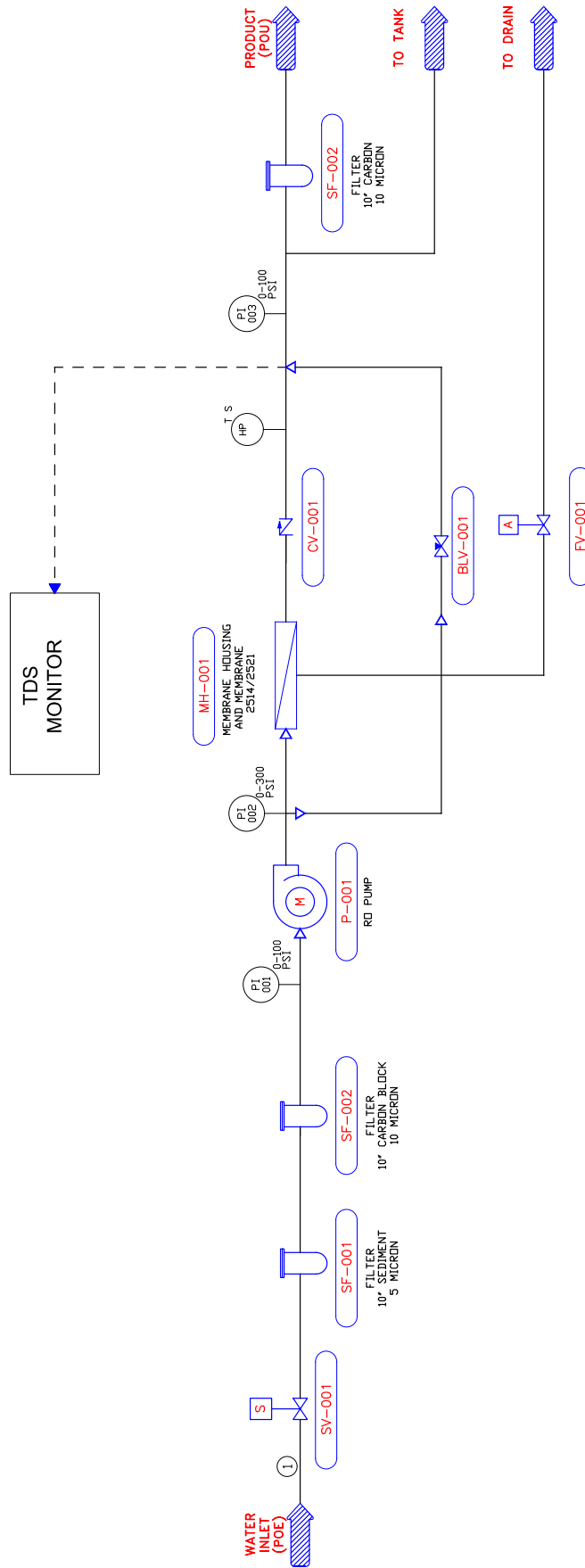



## D. Troubleshooting

### RO Membrane Troubleshooting Guide

SYMPTOMS			LOCATION	POSSIBLE CAUSES	VERIFICATION	CORRECTIVE ACTION
SALT PASSAGE	PERMEATE FLOW	PRESSURE DROP				
Normal to increased	Decreased	Normal to increased	Predominantly first stage	Metal oxide	Analysis of metal ions in cleaning solution.	Improved pretreatment to remove metals. Cleaning with acid cleaners.
Normal to increased	Decreased	Normal to increased	Predominantly first stage	Colloidal fouling	SDI measurement of feed/ X-ray diffraction analysis of cleaning sol. residue.	Optimize pretreatment system for colloid removal. Clean with high pH, anionic detergent formulation.
Increased	Decreased	Increased	Predominantly last stage	Scaling (CaSO <sub>4</sub> , CaSO <sub>3</sub> , BaSO <sub>4</sub> , SiO <sub>2</sub> )	Analysis of metal ions in cleaning sol. Check LSI of reject. Calculate maximum solubility for CaSO <sub>4</sub> , BaSO <sub>4</sub> , SiO <sub>2</sub> in reject analysis.	Increase acid addition and scale inhibitor for CaSO <sub>3</sub> and CaSO <sub>4</sub> . Reduce recovery. Clean with an acid formulation for CaCO <sub>3</sub> , CaSO <sub>4</sub> and BaSO <sub>4</sub> .
Normal to moderate increase	Decreased	Normal to moderate increase	Can occur in any stage	Biological fouling	Bacteria count in permeate and reject. Slime in pipes and vessels.	Shock dosage of sodium bisulfite. Continuous feed of low conc. bisulfite at reduced pH. Peracetic acid cleaning. Clean with alkaline anionic surfactant. Chlorine dosage upstream with dechlorination. Replace cartridge filters.
Decreased or moderately increased	Decreased	Normal	All stages	Organic fouling	Destructive testing, e.g. IR reflection analysis.	Optimization of pretreatment system (e.g. coagulation process.) Resin/ activated carbon treatment. Clean with high pH detergent.
Increased	Increased	Decreased	Most severe in the first stage	Chlorine oxidant attack	Chlorine analysis of feed. Destructive element test.	Check chlorine feed equipment and dechlorination equipment.
Increased	Increased	Decreased	Most severe in the first stage	Abrasion of membrane by crystalline material	Microscopic solids analysis of feed. Destructive element test.	Improved pretreatment. Check all filters for media leakage.
Increased	Normal to increased	Decreased	At random	O-ring leaks, End or side seal glue leaks.	Probe test. Vacuum test. Colloidal material passage.	Replace O-rings. Repair or replace elements.
Increased	Normal to low	Decreased	All stages	Conversion too high.	Check flows and pressures against design guidelines	Reduce conversion rate. Calibrate sensors. Increase analysis and data collection.

## RO System Troubleshooting

SYMPTOMS	POSSIBLE CAUSES	CORRECTIVE ACTION
Low Inlet Pressure	Low supply pressure	Increase inlet pressure
	Cartridge filters plugged	Change filters
	Solenoid valve malfunction	Replace solenoid valve and/or coil
	Leaks	Fix any visible leaks
Low Permeate Flow	Low inlet flow	Adjust concentrate valve
	Cold feedwater	See temperature correction sheet
	Low operating pressure	See low inlet pressure
	Defective membrane brine seal	Inspect and/or replace brine seal
	Fouled or scaled membrane	Clean membranes
High Permeate Flow	Damaged product tube o-rings	Inspect and/or replace
	Damaged or oxidized membrane	Replace membrane
	Exceeding maximum feedwater temperature	See temperature correction sheet
Poor Permeate Quality	Low operating pressure	See low inlet pressure
	Damage product tube o-rings	Inspect and/or replace
	Damaged or oxidized membrane	Replace membrane
Membrane Fouling	Metal oxide fouling	Improve pretreatment to remove metals. Clean with acid cleaners
	Colloidal fouling	Optimize pretreatment for colloid removal. Clean with high pH anionic cleaners
	Scaling (CaSO <sub>4</sub> , CaSO <sub>3</sub> , BaSO <sub>4</sub> , SiO <sub>2</sub> )	Increase acid addition and antiscalant dosage for CaCO <sub>3</sub> and CaCO <sub>4</sub> . Reduce recovery. Clean with acid cleaners
	Biological fouling	Shock dosage of sodium bi-sulfate. Continuous feed of sodium bi-sulfate at reduced pH. Chlorination and de-chlorination. Replace cartridge filters.
	Organic fouling	Activated carbon or another pretreatment. Clean with high pH cleaner
	Abrasion of membrane by crystalline material	Improve pretreatment. Check all filters for media leakage

## V. Replacement Parts List

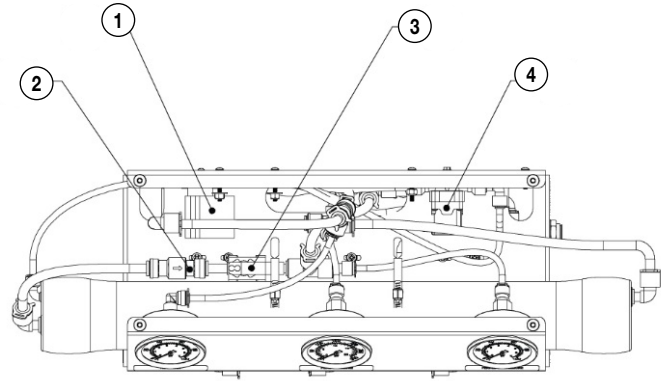
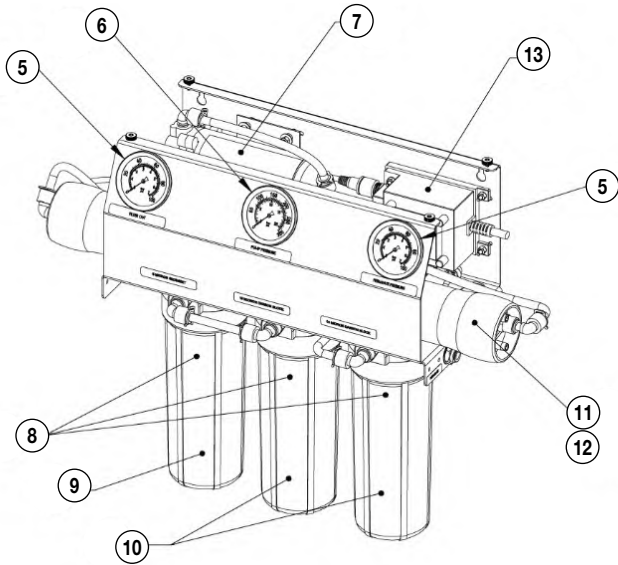

Top View  
Top Cover Removed for Clarity

A list of common replacement parts is provided below. Contact your Watts representative for replacement parts assistance.

ITEM NO.	ORDER CODE	DESCRIPTION
1	500000106	RESTRICTOR, FIXED, 800 ML/MIN, AUTO FLUSH, 1/4" QC
2	500000107	VALVE, CHECK, ACETAL, 3/8" QC X 3/8" QC
3	500000108	SWITCH, TANK, PRESSURE, 20-40 PSI, 3/8" QC
4	500000109	VALVE, SOLENOID, 3/8" QC, 24V
5	500000110	GAUGE, PM, GLY FILL, 0-100 PSI/BAR, 2.5" DIA, 1/4" MNPT
6	500000111	GAUGE, PM, GLY FILL, 0-300 PSI/BAR, 2.5" DIA, 1/4" MNPT
7	500000112	PUMP, BOOSTER, 8800, 3/8" QC
7	500000113	PUMP, BOOSTER, 5800, 1.0 GPM, 24VAC
8	500000114	HOUSING, FILTER, WHT/WHT, 2.5" X 10", SGL O-RING, NPR, 3/8" FNPT
9	500000115	CARTRIDGE, SEDIMENT, POLYPRO, 2.5" X 10", 5 MIC, SDF-25-1005
10	500000116	CARTRIDGE, CARBON, BLOCK, 2.5" X 10", 10 MIC, CBF-25-1010
11	500000117	HOUSING, MEMBRANE, FRP, 2514, 1/4" P X 1/4" C FNPT
11	500000118	HOUSING, MEMBRANE, FRP, 2521, 1/4" P X 1/4" C FNPT
12	68112303	MEMBRANE, WM5-2514, DRY
12	68112304	MEMBRANE, WM5-2521, DRY
13	500000119	TRANSFORMER, 110V 60HZ 24VAC, 4.0 AMP
14	500000133	TDS MONITOR
15	500000122	THREE WAY BLENDING VALVE
16*	500000123	(OPTIONAL) FLOOR-STAND LEG (LONG)
17*	500000124	(OPTIONAL) FLOOR-STAND LEG (SHORT)

\*Not shown

## VI. Membrane Element Specifications

LC-25 Series reverse osmosis systems come standard with WM5 Ultra Low Energy membranes. General membrane element performance characteristics are listed on the following membrane specification chart.

### WM5 Ultra Low Energy Membranes (Standard)

**Membrane Type:** Polyamide Thin – Film Composite

Maximum Operating Temperature: 113°F (45°C)

Maximum Operating Pressure: 400 psi (27.58 bar)

pH Range, Continuous Operation\*: 2 – 11

Maximum Feed Silt Density Index (SDI): 5

Chlorine Tolerance: 0 ppm

Maximum Feed Flow Rate (gpm): 6

\*Maximum temperature for continuous operations above pH 10 is 95°F (35°C).

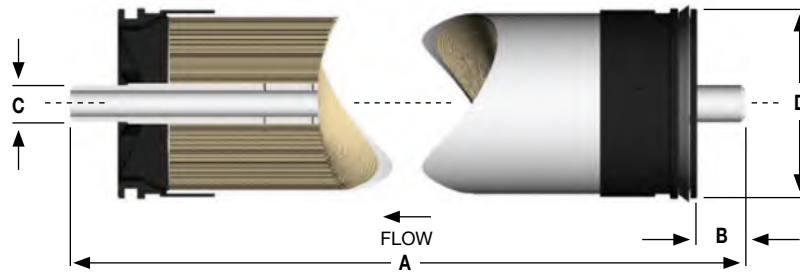

PRODUCT SPECIFICATIONS				DIMENSION INCH / MM			
PART NUMBER	DESCRIPTION	APPLIED PRESSURE PSI / BAR	PERMEATE FLOW RATE GPD / LPD	A	B	C	D
68112303	WM5-2514-ULE	100/6.89	225/0.85	14/355.60	1.10/27.94	0.75/19.05	2.40/60.96
68112304	WM5-2521-ULE	100/6.89	300/0.85	21/533.40	1.10/27.94	0.75/19.05	2.40/60.96

Warranty Evaluation Test Conditions: Permeate flow and salt rejection based on the following test conditions – 550 ppm, filtered and dechlorinated municipal tap water, 77°F / 25°C, 15% recovery and the specified operating pressure. Minimum salt rejection is 96%. Permeate flows for warranty evaluation may vary +/-20%. Maximum pressure drop at 15 psig / 0.9 bar.

Proper start-up of reverse osmosis water treatment systems is essential to prepare the membranes for operating service and to prevent membrane damage due to overfeeding or hydraulic shock. Before initiating system start-up procedures, membrane pretreatment, loading of the membrane elements, instrument calibration and other system checks should be completed.

Avoid any abrupt pressure or crossflow variations on the spiral elements during start-up, shutdown, cleaning or other sequences to prevent possible membrane damage. During start-up, a gradual change from a standstill to operating state is recommended as follows:

- Feed pressure should be increased gradually over a 30 – 60 second time frame.
- Cross – flow velocity at set operating point should be achieved gradually over 15 – 20 seconds.
- Permeate obtained from first hour of operation should be discarded.
- Maximum pressure drop across an entire single membrane pressure vessel (housing) can be up to 15 psi / 1.03 bar.
- Avoid static permeate – side backpressure at all times.

Under certain conditions, the presence of free chlorine, chloramines and other oxidizing agents will cause premature membrane failure. Since oxidation damage is not covered under warranty, the manufacturer recommends removing all oxidizing agents by pretreatment prior to membrane exposure. Please contact the manufacturer or your supplier for more information.

Do not use this initial permeate for drinking water or food preparation. Keep elements moist at all times after initial wetting. To prevent fouling during prolonged system shutdowns, it is recommended that membrane elements be immersed in a preservative solution. Rinse out the preservative before use. For membrane warranty details, please contact your equipment supplier for more information.

If operating limits and guidelines given in this product specification sheet are not strictly followed, the warranty will be null and void. The customer is fully responsible for the effects of incompatible chemicals and lubricants on elements. Use of any such chemicals or lubricants will void the warranty. These membranes may be subject to drinking water application restrictions in some countries; please check the application status before use and sale. The use of this product in and of itself does not necessarily guarantee the removal of cysts and pathogens from water.

No freedom from infringement of any patent owned by the manufacturer or others is to be inferred. Because use conditions and applicable laws may differ from one location to another and may change with time, customer is responsible for determining whether products and the information in this document are appropriate for customer's use and for ensuring that customer's workplace and disposal practices are in compliance with applicable laws and other governmental enactments. The claims made may not have been approved for use in all countries. The manufacturer assumes no obligation or liability for the information in this document. **NO WARRANTIES ARE GIVEN; ALL IMPLIED WARRANTIES OF MERCHANTABILITY OR FITNESS FOR A PARTICULAR PURPOSE ARE EXPRESSLY EXCLUDED.**

## VII. Membrane Installation and Replacement

Installation and replacing membranes in the membrane housings for LC-25 series is an easy process if you have the proper information and tools at hand. Please refer to the following instructions when removing and replacing membrane elements:

### **⚠ WARNING**

**All pressure gauges must read zero before proceeding. Before attempting, disconnect the power from the system and bleed all water pressure from the system.**

1. Remove the end cap from the right (feed water) side of the membrane housings. This is done by removing the two half-moon retaining disks using a #5 Allen wrench, the end plug should then freely slide out of the membrane housing.
2. Remove the membrane bag containing the membrane element from the shipping box. The membrane should be contained within a plastic oxygen barrier bag.

### **NOTICE**

Wear gloves for the following steps in order not to contaminate the membrane.

3. Cut the bag open as close as possible to the seal at one end of the bag, so the bag may be re-used if necessary.
4. Make sure that all parts are clean and free from dirt. Examine the brine seal and permeate tube for nicks or cuts. Replace the o-rings or brine seal if damaged.
5. Flow directions should be observed for installation of the membrane element into the pressure vessels.

### **⚠ WARNING**

**The brine seal must be in the same position as it was for factory pre-installed membrane element. The brine seal is a rubber seal that protrudes on one side of the membrane and is always on the feed side of the membrane element. For LC-25 series RO systems the brine seal should be on the right side of the membrane housing.**

1. Remove membrane element from the right (feed water) side of the membrane housing. Long nose pliers may be necessary to pull the old membrane element out of the membrane element housing.
2. Lubricate the brine seal and o-rings of the new membrane element with a non-petroleum based lubricant. Do not use a petroleum-based lubricant.
3. Install membrane through the right side (feed water) of the membrane housing with brine seal located on the feed water side.
4. With a smooth and constant motion, push the membrane element into the housing so the brine seal enters the housing without coming out of the brine seal groove.
5. Re-install the end plug on the right side by gently twisting the end cap, while pushing it onto the housing. Ensure that you do not pinch or fatigue any o-rings while re-installing the end plug. Push the end plug on until the outer diameter of the plug is flush with the outer diameter of the membrane housing.
6. Insert the two half-moon retaining disks until they are fully seated. Subsequently fasten using a #5 Allen wrench.
7. Reconnect any fittings that may have been disconnected when the membrane housings were disassembled.
8. To start-up the system, please refer to the Start-Up section of this manual.

### **⚠ CAUTION**

**Wet membranes are shipped in a preservative solution. The membranes must be flushed for at least 30 minutes to remove the preservative from the membrane. Discard all of the permeate, which is produced during the flush period.**

# VIII. Appendix

## Temperature Correction Factors

TEMPERATURE °F (°C)	TEMPERATURE CORRECTION FACTOR	TEMPERATURE °F (°C)	TEMPERATURE CORRECTION FACTOR	TEMPERATURE °F (°C)	TEMPERATURE CORRECTION FACTOR	TEMPERATURE °F (°C)	TEMPERATURE CORRECTION FACTOR	TEMPERATURE °F (°C)	TEMPERATURE CORRECTION FACTOR
50.0 (10.0)	1.711	57.2 (14.0)	1.475	64.4 (18.0)	1.276	71.6 (22.0)	1.109	78.8 (26.0)	0.971
50.2 (10.1)	1.705	57.4 (14.1)	1.469	64.6 (18.1)	1.272	71.8 (22.1)	1.105	79.0 (26.1)	0.968
50.4 (10.2)	1.698	57.6 (14.2)	1.464	64.8 (18.2)	1.267	72.0 (22.2)	1.101	79.2 (26.2)	0.965
50.5 (10.3)	1.692	57.7 (14.3)	1.459	64.9 (18.3)	1.262	72.1 (22.3)	1.097	79.3 (26.3)	0.962
50.7 (10.4)	1.686	57.9 (14.4)	1.453	65.1 (18.4)	1.258	72.3 (22.4)	1.093	79.5 (26.4)	0.959
50.9 (10.5)	1.679	58.1 (14.5)	1.448	65.3 (18.5)	1.254	72.5 (22.5)	1.090	79.7 (26.5)	0.957
51.1 (10.6)	1.673	58.3 (14.6)	1.443	65.5 (18.6)	1.249	72.7 (22.6)	1.086	79.9 (26.6)	0.954
51.3 (10.7)	1.667	58.5 (14.7)	1.437	65.7 (18.7)	1.245	72.9 (22.7)	1.082	80.1 (26.7)	0.951
51.4 (10.8)	1.660	58.6 (14.8)	1.432	65.8 (18.8)	1.240	73.0 (22.8)	1.078	80.2 (26.8)	0.948
51.6 (10.9)	1.654	58.8 (14.9)	1.427	66.0 (18.9)	1.236	73.2 (22.9)	1.075	80.4 (26.9)	0.945
51.8 (11.0)	1.648	59.0 (15.0)	1.422	66.2 (19.0)	1.232	73.4 (23.0)	1.071	80.6 (27.0)	0.943
52.0 (11.1)	1.642	59.2 (15.1)	1.417	66.4 (19.1)	1.227	73.6 (23.1)	1.067	80.8 (27.1)	0.940
52.2 (11.2)	1.636	59.4 (15.2)	1.411	66.6 (19.2)	1.223	73.8 (23.2)	1.064	81.0 (27.2)	0.937
52.3 (11.3)	1.630	59.5 (15.3)	1.406	66.7 (19.3)	1.219	73.9 (23.3)	1.060	81.1 (27.3)	0.934
52.5 (11.4)	1.624	59.7 (15.4)	1.401	66.9 (19.4)	1.214	74.1 (23.4)	1.056	81.3 (27.4)	0.932
52.7 (11.5)	1.618	59.9 (15.5)	1.396	67.1 (19.5)	1.210	74.3 (23.5)	1.053	81.5 (27.5)	0.929
52.9 (11.6)	1.611	60.1 (15.6)	1.391	67.3 (19.6)	1.206	74.5 (23.6)	1.049	81.7 (27.6)	0.926
53.1 (11.7)	1.605	60.3 (15.7)	1.386	67.5 (19.7)	1.201	74.7 (23.7)	1.045	81.9 (27.7)	0.924
53.2 (11.8)	1.600	60.4 (15.8)	1.381	67.6 (19.8)	1.197	74.8 (23.8)	1.042	82.0 (27.8)	0.921
53.4 (11.9)	1.594	60.6 (15.9)	1.376	67.8 (19.9)	1.193	75.0 (23.9)	1.038	82.2 (27.9)	0.918
53.6 (12.0)	1.588	60.8 (16.0)	1.371	68.0 (20.0)	1.189	75.2 (24.0)	1.035	82.4 (28.0)	0.915
53.8 (12.1)	1.582	61.0 (16.1)	1.366	68.2 (20.1)	1.185	75.4 (24.1)	1.031	82.6 (28.1)	0.913
54.0 (12.2)	1.576	61.2 (16.2)	1.361	68.4 (20.2)	1.180	75.6 (24.2)	1.028	82.8 (28.2)	0.910
54.1 (12.3)	1.570	61.3 (16.3)	1.356	68.5 (20.3)	1.176	75.7 (24.3)	1.024	82.9 (28.3)	0.908
54.3 (12.4)	1.564	61.5 (16.4)	1.351	68.7 (20.4)	1.172	75.9 (24.4)	1.021	83.1 (28.4)	0.905
54.5 (12.5)	1.558	61.7 (16.5)	1.347	68.9 (20.5)	1.168	76.1 (24.5)	1.017	83.3 (28.5)	0.902
54.7 (12.6)	1.553	61.9 (16.6)	1.342	69.1 (20.6)	1.164	76.3 (24.6)	1.014	83.5 (28.6)	0.900
54.9 (12.7)	1.547	62.1 (16.7)	1.337	69.3 (20.7)	1.160	76.5 (24.7)	1.010	83.7 (28.7)	0.897
55.0 (12.8)	1.541	62.2 (16.8)	1.332	69.4 (20.8)	1.156	76.6 (24.8)	1.007	83.8 (28.8)	0.894
55.2 (12.9)	1.536	62.4 (16.9)	1.327	69.6 (20.9)	1.152	76.8 (24.9)	1.003	84.0 (28.9)	0.892
55.4 (13.0)	1.530	62.6 (17.0)	1.323	69.8 (21.0)	1.148	77.0 (25.0)	1.000	84.2 (29.0)	0.889
55.6 (13.1)	1.524	62.8 (17.1)	1.318	70.0 (21.1)	1.144	77.2 (25.1)	0.997	84.4 (29.1)	0.887
55.8 (13.2)	1.519	63.0 (17.2)	1.313	70.2 (21.2)	1.140	77.4 (25.2)	0.994	84.6 (29.2)	0.884
55.9 (13.3)	1.513	63.1 (17.3)	1.308	70.3 (21.3)	1.136	77.5 (25.3)	0.991	84.7 (29.3)	0.882
56.1 (13.4)	1.508	63.3 (17.4)	1.304	70.5 (21.4)	1.132	77.7 (25.4)	0.988	84.9 (29.4)	0.879
56.3 (13.5)	1.502	63.5 (17.5)	1.299	70.7 (21.5)	1.128	77.9 (25.5)	0.985	85.1 (29.5)	0.877
56.5 (13.6)	1.496	63.7 (17.6)	1.294	70.9 (21.6)	1.124	78.1 (25.6)	0.982	85.3 (29.6)	0.874
56.7 (13.7)	1.491	63.9 (17.7)	1.290	71.1 (21.7)	1.120	78.3 (25.7)	0.979	85.5 (29.7)	0.871
56.8 (13.8)	1.486	64.0 (17.8)	1.285	71.2 (21.8)	1.116	78.4 (25.8)	0.977	85.6 (29.8)	0.869
57.0 (13.9)	1.480	64.2 (17.9)	1.281	71.4 (21.9)	1.112	78.6 (25.9)	0.974	85.8 (29.9)	0.866

$^{\circ}\text{F}=(^{\circ}\text{C} \times 9/5) + 32$

Corrected Flow Rate= (Measured Flow Rate) \* (TCF @ Feed Water Temp.)

## Watts Commercial RO System Limited Warranty

Watts Regulator Co. (the "Company") warrants each product to be free from defects in material and workmanship under normal usage for a period of one year from the date of original shipment. In the event of such defects within the warranty period, the Company will, at its option, replace or recondition the product without charge.

**THE WARRANTY SET FORTH HEREIN IS GIVEN EXPRESSLY AND IS THE ONLY WARRANTY GIVEN BY THE COMPANY WITH RESPECT TO THE PRODUCT. THE COMPANY MAKES NO OTHER WARRANTIES, EXPRESS OR IMPLIED. THE COMPANY HEREBY SPECIFICALLY DISCLAIMS ALL OTHER WARRANTIES, EXPRESS OR IMPLIED, INCLUDING BUT NOT LIMITED TO THE IMPLIED WARRANTIES OF MERCHANTABILITY AND FITNESS FOR A PARTICULAR PURPOSE.**

The remedy described in the first paragraph of this warranty shall constitute the sole and exclusive remedy for breach of warranty, and the Company shall not be responsible for any incidental, special or consequential damages, including without limitation, lost profits or the cost of repairing or replacing other property which is damaged if this product does not work properly, other costs resulting from labor charges, delays, vandalism, negligence, fouling caused by foreign material, damage from adverse water conditions, chemical, or any other circumstances over which the Company has no control, including without limitation the use of incompatible chemicals and lubricants. This warranty shall be invalidated by any abuse, misuse, misapplication, improper installation or improper maintenance or alteration of the product, as well as any failure to install, operate or maintain the product in strict accordance and adherence with the product's operating documentation and manuals.

Some States do not allow limitations on how long an implied warranty lasts, and some States do not allow the exclusion or limitation of incidental or consequential damages. Therefore the above limitations may not apply to you. This Limited Warranty gives you specific legal rights, and you may have other rights that vary from State to State. You should consult applicable state laws to determine your rights. **SO FAR AS IS CONSISTENT WITH APPLICABLE STATE LAW, ANY IMPLIED WARRANTIES THAT MAY NOT BE DISCLAIMED, INCLUDING THE IMPLIED WARRANTIES OF MERCHANTABILITY AND FITNESS FOR A PARTICULAR PURPOSE, ARE LIMITED IN DURATION TO ONE YEAR FROM THE DATE OF ORIGINAL SHIPMENT.**



USA: T: (800) 659-8400 • Watts.com

Canada: T: (905) 332-4090 • Watts.ca

Latin America: T: (52) 55-4122-0138 • Watts.com

