



AHB

TOOLING & MACHINERY

COMPLETE METALWORKING SOLUTIONS

(800) 991-4225

www.ahbinc.com

ISO Certified

customerservice@ahbinc.com

CUTTING TOOL STORAGE GUIDE

Since 1926, a commitment to you, our customer.

Nearly a century ago, Gene Huot (pronounced “Hewitt”) invented and marketed the famous Drill Index, a significant industry breakthrough and one which has successfully withstood the test of time.

Since the introduction of this remarkable product, Huot has grown to become one of the most respected names in its field, with a world-wide reputation for quality, innovation and service.

The products in this catalog are designed to efficiently and effectively meet your specific requirements. Each is quality-made to meet the highest standards of excellence. Only in this way can we earn your complete satisfaction and maintain your continued trust in our products and services.

All Huot products are proudly made in the U.S.A.

We're small enough to care and big enough to get it done.

5S Initiatives

We've all heard the term “5S”, but what is it and how does it work? In an effort to increase competitiveness, 5S was developed by the Japanese to cut costs, increase efficiency and quality, and ultimately become more profitable. Expanding on lean initiatives, this benchmark for quality programs is used by companies around the world. These simple ideas were developed for manufacturing purposes but can improve efficiency anywhere you apply them. Here are the 5 words and their meanings:

- SORT** – Determine what is needed for an area and remove what isn't.
- SET** (in order) – Designate a place for everything in the area, and keep it there when not in use.
- SHINE** – Always keep the area clean and organized.
- STANDARDIZE** – Make the area and processes efficient and visually obvious, and do the same for similar areas.
- SUSTAIN** – Ensure the initiatives are constantly followed in all areas.

Some say that the 6th and 7th initiatives are Safety and Security, but the developers wanted to keep it simple at 5. Huot Manufacturing makes the products that will help you meet your 5S goals in your shop, including the 6th and 7th initiatives.

If you are thinking 5S, think Huot.

Cuttings tools, wrenches and toolholders shown throughout this catalog are for pictorial use only and are not included with any Huot products.

SCOOTS

ToolScoot Tree..... 6-7
 SuperScoot 9
 ToolScoot 4
 TriScoot..... 5
 SpeedyScoot 11
 Limited..... 10

TOOLSCOOT ACCESSORIES

Doors 4
 Safety Covers..... 10
 Toolholder Vises 3 & 9

TOWERS

SuperTower 12
 ToolTower 12
 Stacking Kits..... 12
 Shop Tower 17

WALL MOUNTABLE

Wall or machine mount racks 14 & 16

BENCH TOP PLATFORMS

Racks 14-16

PORTABLE

Tool Totes 16

DRILL DISPENSERS

Fractional 18-20
 Wire 19
 Letter 19
 Silver Deming 19-20
 Taper Shank/Length 20
 Metric 19-20

TAP DISPENSERS

..... 20-21

TAP & DRILL DISPENSERS

..... 20-21

END MILL DISPENSERS

..... 22

REAMER DISPENSERS

..... 22

INSERT DISPENSERS

..... 23

BURR DISPENSER

..... 21

UNIVERSAL DISPENSER

..... 23

INDEX CASES & STANDS

Bit Buddy 26
 Drills 25-26
 Metric 26
 Reamers 25
 Stub/Screw machine length 27
 Silver Deming 27-28
 Screw Extractor 25
 Taper Shank/Taper Length 27
 Tap 28
 Burr 27
 Stands 29
 Tap & Drill 28
 Gauges 29

COLLET RACKS

..... 15-16

CAN RACK, SPRAY BOTTLE RACKS

..... 29

MOLDED INSERTS

..... 30

Workstation

*Vise sold separately

The Huot Workstation provides a solid, stable work location with plenty of functional top surface space and was designed with a machine shop environment in mind. Everything you need to be productive is stored and organized right at your fingertips, with the ability to lock it up when finished. Placed next to a machine, the workstation provides a valuable resource for a machine operator's daily functions.

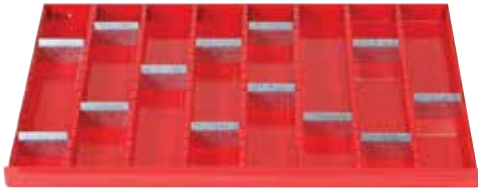

Interior view of top 2 drawers



Scan for YouTube video



EDP#	Description	Capacity
	34" L x 22.75" W x 39" H, 285 lbs	
77230	30 taper toolholders	30
77240	40 taper toolholders	30
77250	50 taper toolholders	18
77270	HSK63A toolholders	30
77280	HSK100A toolholders	18
79342	QG-42 Workstation	30
79365	QG-65 Workstation	16
79380	QG-80 Workstation	16
79399	QG-100 Workstation	11
79624	CAPTO C4 Workstation	30
79625	CAPTO C5 Workstation	30
79626	CAPTO C6 Workstation	30
79628	CAPTO C8 Workstation	30

- Durable hardwood butcher block top with plenty of work space
- Top 2 drawers utilize welded columns with dividers every 1" for customizing storage and organization (see inset photo).
- Larger 4" drawer is open for larger tools and miscellaneous items
- Bottom tooling drawer holds up to 30 toolholders depending on taper size
- Cabinet has threaded holes on both sides for mounting a Huot tool changing vise* horizontally or vertically (shown)
- Heavy duty welded steel construction
- Locking doors protect against chips & debris and keep valuable tools secure
- All drawers use full extension ball bearing slides
- Cabinet pockets allow for movement with a forklift

EDP #77277 Work-Surface Extension

This handy extension bolts to the side of the Workstation and effectively doubles the work surface. With a thick Maple top it makes an ideal base for a presetter or a shrink fit system. The lower shelf can be mounted at numerous heights to accommodate a CPU or a chiller, with adequate ventilation and cable/hose access. The outer leg is pre-punched to mount a Huot Machine Mount Rack (not included, see page 12) for even greater toolholder storage.

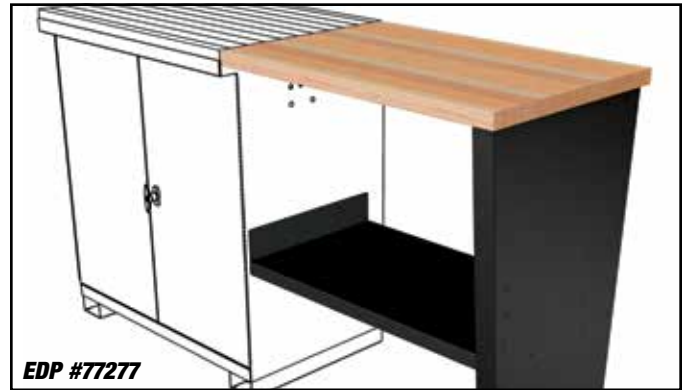

Toolholder Vises

Heavy duty vise designed to be bolted directly to our ToolScoat side shelves, work bench or any place heavy tool changing is performed. These unique products provide a quick and easy method for changing cutting tools and pull studs.

- EDP #50525 For 40 CAT-V EDP #50526 For 40 BT EDP #50527 For 50CAT-V EDP #50528 For 50 BT
 EDP #50563 For HSK63A and KM63 and HSK63F EDP #50523 For CAT-V 30 EDP #50524 For BT 30



ToolScoot™/Tool Cart for CNC V-Flange, HSK and CAPTO*



EDP #13940



Scan for
YouTube video

Quality and mobility at an affordable price. Molded inserts on both shelves help protect tool holders. Lower shelf angled for quick, easy tool access from either side. Solid, interlocking side panel construction for maximum strength and stability. Two end storage trays with universal mounting holes for toolholder vise. Heavy duty 5" x 1 1/4" casters load rated at 1000 lbs. All steel painted with our durable Ecolo-Clad in red and black.

EDP#	Description 18" W x 35.25" L x 35" H, 75 lbs.	Capacity
13930	BT, CAT "V" Flange, NMTB for 30 taper	48
13940	BT, CAT "V" Flange, NMTB for 40 taper	48
13949	HSK 40A, 40C, 40E and KM40 toolholders	36
13950	BT, CAT "V" Flange, NMTB For 50 taper	36
13955	16C collets	100
13960	5C collets	96
13965	R8 or #4 Morse Tape	96
13970	HSK 63A toolholders	48
13980	HSK 100A toolholders	36
13984	C4 CAPTO* style ToolScoot	48
13985	C5 CAPTO* style ToolScoot	48
13986	C6 CAPTO* style ToolScoot	48

*CAPTO Registered Trademark Sandvik Corp.

See #13778 C8 CAPTO style TriScoot on page 4

ToolScoot Accessories

EDP #14875 ToolScoot Cover

Cover for the original ToolScoot provides protection for your valuable CNC tooling. The See-through front and back panes provide at-a-glance locating of the right tools for your job while keeping them clean from chips and unintentional contact from a passerby. Cover comes with rigid metal support frames that bolt onto your Huot ToolScoot providing 18" of space between the top shelf and the cover. Covers are commercially sewn from 19 mil, double polished clear vinyl and black 18 oz. vinyl-coated nylon. Covers are for the Original Huot ToolScoot product only.



EDP #14875



EDP #50515

EDP #50515 ToolScoot Doors

Doors are built from 16 gauge steel for strength with a polycarbonate window for visibility and protection along with a cam style lock for security. A large barrel piano style hinge makes installation a snap. Order one set of doors per side of traditional 2-shelf ToolScoot.

EDP #14145 ToolScoot Top Doors

- Replaces top shelf on original ToolScoot
- May reduce likelihood of accidental contact with tooling
- Hinged doors allow for easy access
- Installs quickly and easily



EDP #14145

SecurityScoot

Store, organize, and lock up your CNC toolholders. The demand and need for locking up tools is increasing every day. The SecurityScoot provides a large, functional tray top, with toolholder storage and organization on 2nd and 3rd shelves, along with the added benefit of safety and security for your tooling. Enjoy the utility this unique product provides, and the peace of mind of knowing your tooling is locked up.

- Side tray allows for optional tool changing vise or collet racks
- Comes with 2 sets of doors to secure both sides
- Clear polycarbonate allows for easy at-a-glance tool identification
- Sturdy steel construction with scratch resistant powder finish
- Large open tray area for utility transport
- Doors are keyed alike for easy operation and security
- Shelves can be adjusted in 7 different mounting positions
- Heavy duty 5" locking casters provide stability

EDP#	Description 41" H x 35" W x 20" D, 127 lbs	Capacity
16930	30 taper toolholders	48
16940	40 taper toolholders	48
16950	50 taper toolholders	36
16970	HSK63A taper toolholders	48
16980	HSK100A taper toolholders	36



TriScoot

The world famous Huot ToolScoot is now available with 3 shelves for even more storage space in the same footprint. This cart is ruggedly built just like the original but with a third more capacity and standing almost 7" taller.



EDP#	Description 18" W x 20.25" L x 41" H, 75 lbs	Cap.
13309	BT, CAT "V" Flange, NMTB For 30 taper	72
13435	BT, CAT "V" Flange, NMTB For 35 taper	72
13409	BT, CAT "V" Flange, NMTB For 40 taper	72
13545	BT, CAT "V" Flange, NMTB For 45 taper	54
13509	BT, CAT "V" Flange, NMTB For 50 taper	54
13774	CAPTO style C4 toolholders	72
13775	CAPTO style C5 toolholders	72
13776	CAPTO style C6 toolholders	72
13778	CAPTO style C8 toolholders	54
13916	3J Collets	72
13962	HSK 100A toolholders	54
13963	KM63 or HSK63A toolholders	72
13964	HSK 40A toolholders	72
13968	HSK 63F toolholders	72
13993	#30 VDI toolholders (not V-flange)	72
13994	#40 VDI toolholders (not V-flange)	72
14865	Side Tray to store collets, wrenches & supplies	N/A
77342	#42 Quick grip collet TriScoot	54
77365	#65 Quick grip collet TriScoot	45
77380	#80 Quick grip collet TriScoot	39
77399	#100 Quick grip collet TriScoot	30

ToolScoot Tree

- Slotted uprights provide 35 possible shelf locations on each side of cart (70 total).
- Heavy 14 gauge unibody chassis with see through design.
- Includes 6 shelves - 5 for toolholders and 1 for utility.
- Molded inserts protect and securely hold toolholders.
- Every 5th slot marked for easy shelf positioning.
- Shelves can be positioned flat or at a -20° angle.
- 16 gauge steel shelves for strength and rugged durability.
- Casters are load rated to 1,600 pounds.
- Heavy duty 5" casters - two swivel with brakes and two stationary.



EDP#	Description	28.5" W x 57" H x 28" D, 135 lbs.	Cap.
55930	BT, CAT "V" flange, NMTB 30 taper toolholders		90
55940	BT, CAT "V" flange, NMTB 40 taper toolholders		90
55950	BT, CAT "V" flange, NMTB 50 taper toolholders		50
55955	16C collets		180
55964	HSK 40A toolholders		90
55970	HSK 63A toolholders		90
55973	R8 collets		250
55974	5C collets		250
55976	HSK 63F toolholders		90
55980	HSK 100A toolholders		50
55984	CAPTO C4 style toolholders		90
55985	CAPTO C5 style toolholders		90
55986	CAPTO C6 style toolholders		90
55988	CAPTO C8 style toolholders		50
EDP#	Accessories		
55110	Utility Shelf		N/A
55111	Maple Butcher Block Shelf Insert		N/A
55114	18 hole Custom-U-Size-It Shelf		18
55115	10 hole Custom-U-Size-It Shelf		10
55140	40 Taper Extra Shelf		18
55155	16C Extra Shelf		36
55164	HSK 40A Extra Shelf		18
55173	R8 shelf		50
55174	5C shelf		50
55170	HSK 63A Extra Shelf		18
55150	50 Taper Extra Shelf		10
55180	HSK 100A Extra Shelf		10
55242	Quick change #42 shelf		17
55265	Quick change #65 shelf		12
55280	Quick change #80 shelf		8
55299	Quick change #100 shelf		6



Utility Shelf comes standard with each Tree. We have created five new ER & TG Collet racks specifically designed to fit perfectly in this shelf. Please see page 15 for details.



**Proudly made
in the USA**



Scan for
YouTube video

Tall ToolScoot Tree



Our Tall ToolScoot Tree is 12" taller than our original model and offers many unique and useful features.

- Ergonomics. More comfortable shelf heights
- The tallest tree-type tool storage on the market
- High shelves offer access to mezzanine operators
- Six shelves are included
- Greater capacity in the same footprint
- Increased spacing between shelves



Built-in pegboard holes for hanging just about anything



Built-in slots provide easy and convenient storage for your spanner wrenches

EDP#	Description 28.5" W x 69" H x 28" D, 149 lbs.	Capacity
55330	holds 30 taper toolholders	90
55340	holds 40 taper toolholders	90
55350	holds 50 taper toolholders	50
55370	holds HSK 63A taper toolholders	90
55380	holds HSK 100A taper toolholders	50

Other sizes including CAPTO, VDI, HSK40A are also available.



Bigger, Badder, Beefier are just a few of the ways to describe the UltraScoot. Constructed of 12 gauge cold rolled steel, this monster leaves our factory with the chassis fully MIG welded so all you have to do is bolt on the casters and you're in business.

- UltraScoot comes with 4 adjustable shelves. Additional shelves may be ordered separately.
- Shelves have 11 possible mounting locations per side.
- Six casters, 4 swivel and 2 rigid load rated at a whopping 7,200 pounds.
- Strong tubular handle makes it easy to push or pull.
- Durable gold vein shelves with textured black chassis.
- Side shelf pre-punched for mounting a toolholder vise or universal dispenser.
- Tool changing vise sold separately (see page 9).
- Universal Master Dispenser fits perfectly in side shelf (see page 23).
- Customizable for live tooling heads. Contact the factory for details.
- See safety covers on page 4.



EDP#	Description	Capacity
	75.25" W x 42.25" H x 29.75" D, 254 lbs. (Width includes handle & tray. Ships LTL.)	
99940	BT, CAT "V" flange, NMTB 40 taper toolholders	176
99950	BT, CAT "V" flange, NMTB 50 taper toolholders	120
99960	CAT 60 toolholders	64
99970	HSK 63A toolholders	176
99980	HSK 100A toolholders	120
99125	HSK 125A toolholders	96
EDP#	Accessories	
14899	Extra side shelf (1 is included)	
13174	Battleship Grey Universal Master Dispenser (see page 23)	

UltraScoop II

Our heavy duty 12 gauge UltraScoop II is perfect for larger toolholders with long tools in them. Flat shelves are safer and sturdier for transporting and storing.

- Side shelf for dispenser or tool vise
- Eleven shelf mounting positions
- Heavy duty casters are chip resistant
- Tubular handle for ergonomic comfort
- Sturdy mig welded frame
- Outrigger design adds stability
- Molded inserts protect tool tapers
- Closed sides protect tools

EDP#	Description 45" W x 42" H x 26" D, 127 lbs. (Width includes handle & tray. Ships LTL.)	Capacity
99730	BT, CAT "V" flange, NMTB 30 taper toolholders	88
99740	BT, CAT "V" flange, NMTB 40 taper toolholders	88
99750	BT, CAT "V" flange, NMTB 50 taper toolholders	60
99760	CAT 60 toolholders	32
99770	HSK 63A toolholders	88
99780	HSK 100A toolholders	60
99725	HSK 125A toolholders	48



CNC V-Flange and HSK SuperScoop™



- Constructed of prime 12 gauge steel for rugged heavy duty use.
- Almost twice the storage capacity!
- Heavy duty, extra smooth rolling casters load rated to 1600 lbs. for long caster life, with locking caster mechanism.
- Baked on gold vein powder coating for lasting durability.
- Phosphate pretreatment undercoating for additional toughness.
- Designed for maximum toolholder capacity per square foot of cart space.
- Outrigger design for improved stability and easier maneuverability.



Scan for
YouTube video

EDP#	Description 45.25" W x 17.5" D x 40" H, 132 lbs. (width includes handle & tray)	Capacity
23930	30 taper toolholders, 45 per shelf	90
23940	40 taper toolholders, 45 per shelf	90
23950	50 taper toolholders, 26 per shelf	52
23970	HSK 63A taper, 45 per shelf	90
23980	HSK 100A taper, 26 per shelf	52

Toolholder Vises

Heavy duty vise designed to be bolted directly to our ToolScoop side shelves, work bench or any place heavy tool changing is performed. These unique products provide a quick and easy method for changing cutting tools and pull studs.

- EDP #50525** For 40 CAT-V
 EDP #50526 For 40 BT
 EDP #50527 For 50CAT-V
 EDP #50528 For 50 BT
EDP #50563 For HSK63A and KM63 and HSK63F
 EDP #50523 For CAT-V 30
 EDP #50524 For BT 30



ToolScoot Ltd

- Ideal for special ops applications
- Molded inserts protect and securely hold toolholders
- Sturdy steel construction with scratch resistant powder finish
- Drawers use full extension ball bearing slides
- 2" drawer with welded columns and adjustable dividers
- 6" drawer has two sets of ball bearing slides for larger tools and greater weight capacity
- Welded chassis adds strength and rigidity (ships LTL)
- Minimal assembly required, simply bolt on casters
- Side tray holds collet racks, tool changing vise or miscellaneous tools
- Grab handle for easy maneuverability
- Dimensions are 41" L x 35.25" H x 18" D
- Casters are load rated to 1600 lbs

EDP#	Description	Capacity
13640	Holds CAT 40 taper toolholders	24
13655	Holds CAT 50 taper toolholders	18
13670	Holds HSK63A toolholders	24
13680	Holds HSK100A toolholders	18

Custom sizes also available. Call or email the factory for assistance.



EDP #13640

CNC Tooling Safety Covers

- Protects your expensive tooling from getting nicked and marred.
- Tooling is kept clean and a dry marker can be used for set-ups.
- Covers are held in place with key-hole slots molded into the base.
- Protects operator from injuries and allows for tool visibility.
- Semi-transparent top reduces industrial espionage.

EDP#	Description	14" H, 0.5 lbs.
14000	Semi-transparent - 30, 35, 40 or HSK63A tapers	
14001	Clear - 30, 35, 40 or HSK63A tapers	
14015	Semi-transparent - 45, 50 or HSK100A tapers	
14016	Clear - 45, 50 or HSK100A tapers	



*Scan for
YouTube video*



V-Flange & HSK SpeedyScoat



- Only 15" wide, SpeedyScoat™ lets you easily move tooling through narrow spaces between machines and around tight corners.
- Built heavy duty for the factory floor, SpeedyScoat combines rugged quality and easy mobility at an affordable price.
- Solid side panel construction for maximum strength, stability and cleanliness.
- Durable nylon inserts to help prevent tooling damage.

- Heavy duty 4" x 1-1/2" casters load rated at 1000 lbs.
- All steel infrared-baked epoxy finish in textured black with phosphate pretreatment.
- Options to suit your production needs including middle shelves and drawers.



EDP#	V-Flange & HSK SpeedyScoat 15" W x 30" L x 35" H, 52 lbs	Capacity
33940	BT, CAT "V" Flange, NMTB For 40 taper	24 ¹
33950	BT, CAT "V" Flange, NMTB For 50 taper	15 ¹
33970	HSK 63A	24 ¹
33980	HSK 100A	15 ¹

1. Double tooling capacity with optional second shelf (see below).

SpeedyScoat™ Accessories



EDP#	SpeedyScoat Accessories	Capacity
30001	Tool drawer, ball bearing slides, built in cam lock ¹ . 14 lbs.	N/A
14190	2nd flat shelf without holes for bulk storage, 6 lbs.	N/A
14170	2nd shelf for 40 taper, 6 lbs.	24
14175	2nd shelf for 50 taper, 6 lbs.	15
14180	2nd shelf for HSK 63A, 6 lbs.	24
14185	2nd shelf for HSK 100A, 6 lbs.	15

1. Requires EDP #14190 2nd shelf without holes for mounting drawer.

Custom Scoot

We realize not everyone has machines that use common CAT, BT, HSK etc tooling. In an effort to help those who found that *great deal* on a machine that uses tooling from another planet, we've devised a method to accommodate their needs. Instead of using a molded insert to grip the toolholder, we use a sheet of 3/8" polycarbonate customized to your specific tool and mounted to a metal shelf. The shelf supports the weight of the toolholders and the polycarbonate acts as the insert. The toolholder is held by the D1 dimension of the tool, based on the toolholder's taper. It's that simple. Call or email us today for more information.

EDP #13914 24 holes per shelf, total of 72

EDP #13915 18 holes per shelf, total of 54

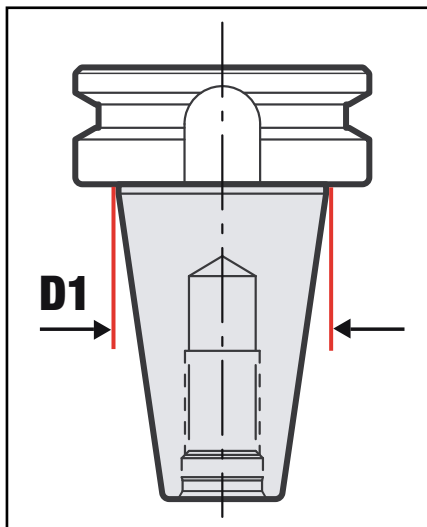

SuperTower

- Constructed of prime 12 gauge steel for rugged heavy duty use.
- Finished in beautiful gold vein powder coating, baked on for lasting durability.
- Phosphate pretreatment undercoating for additional toughness.
- Angled shelving for easier, quicker tool access.
- Additional shelves available.
- Can be stored inside a standard 36" x 18" wide cabinet.
- Almost twice the storage capacity for less!
- Heavier duty than others in its class.
- Tower is stackable two high to expand your storage area (see illustration).
- For added safety ToolTower should be bolted to a wall.

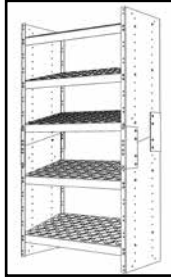

EDP#	Description	Capacity
	33.75" W x 17.5" D x 33.5" H, 95 lbs.	
23830	30 taper toolholders, 45 per shelf	135
23840	40 taper toolholders, 45 per shelf	135
23850	50 taper toolholders, 26 per shelf	78
23870	HSK 63A toolholders, 45 per shelf	135
23880	100A toolholders, 26 per shelf	78
EDP#	Accessories	Weight
24860	Stacking Kit - stack 2 SuperTowers together	10 lbs.

ToolTower for CNC V-Flange, HSK, VDI & CAPTO*



EDP #13840
Shown with two stacked

The Huot NC ToolTower provides an economical free standing storage unit for toolholders. It comes with 3 shelves and can be stacked to form a 5 or 6 shelf tower, providing a cost effective way to store and protect many NC toolholders in a compact space.

- Molded inserts protect each tool holder.
- Sturdy 16 gauge steel construction.
- Optional tool lock tray can be mounted on either side panel.
- ToolTower should be bolted to the floor for additional security.
- UPS shippable.



EDP#	Description	Capacity
	27.3125" W x 18.3125" D x 36" H, 65 lbs	
13830	30 taper toolholders, 24 per shelf	72
13840	40 taper toolholders, 24 per shelf	72
13850	50 taper toolholders, 18 per shelf	54
13858	20C collets, 24 per shelf	72
13860	5C collets, 50 per shelf	150
13864	HSK 40A, 40C, 40E, KM40	72
13865	R8 or #4 Morse Taper tools, 50 per shelf	150
13870	HSK 63A, 24 per shelf	72
13880	HSK 100A, 18 per shelf	54
13884	C4 (CAPTO style) ToolTower	72
13885	C5 (CAPTO style) ToolTower	72
13886	C6 (CAPTO style) ToolTower	72
13888	C8 (CAPTO style) ToolTower	54
13890	16C collets, 50 per shelf	150
13893	#30 VDI, 24 per shelf	72
13894	#40 VDI, 24 per shelf	72

*CAPTO Registered Trademark Sandvik Corp.

EDP#	Accessories	Weight
14860	Stacking Kit - stack two ToolTowers together	7 lbs.
14865	Tool Lock Tray	
50520	One set of doors for ToolTower	

CNC Wall Tree Locker



Also available for CAPTO®

The Huot Tree Lockers store, organize and protect your toolholders from dust, debris and theft. Increase your productivity and efficiency with other Huot products designed specifically for production shop use.

- Shelves mount flat or at a -20° angle for easy viewing and access
- Includes 5 toolholder shelves (Tall Tree Locker) or 3 toolholder shelves (Wall Tree Locker) available in all popular tapers
- Molded inserts protect and securely hold toolholders
- Toolholder shelves interchange with our ToolScoot Trees
- Frame and shelves made of rugged 12 and 16 gauge steel
- Different taper toolholder shelves can be used together
- Reinforced doors lock to keep valuable tools secure and protect against chips and debris
- Accessories for shelves are available for your specific needs
- Finished with a baked on powder coat for lasting durability
- Tall Tree Lockers should be securely fastened to a wall for added safety

EDP#	Description	34.25" W x 16.125" D x 74" H, 210 lbs.	Cap.
55631	30 taper toolholders		90
55641	40 taper toolholders		90
55651	50 taper toolholders		50
55671	HSK 63A toolholders		90
55681	HSK 100A toolholders		50



See page 6 for a complete listing of available extra shelves

EDP#	Description	31.25" W x 15.75" D x 46.5" H, 110 lbs.	Capacity
55731	30 taper toolholders		54
55741	40 taper toolholders		54
55751	50 taper toolholders		30
55771	HSK 63A toolholders		54
55781	HSK 100A toolholders		30

Machine Mount Rack



EDP #56740

- 14 slots per side for a variety of shelf height adjustments
- Shelves mount flat or at a -20° angle for easy tool presentation
- Molded inserts (included) protect and securely hold toolholders
- 6 mounting locations ensure a sturdy, solid fit to the machine
- Large capacity - up to 28 tools total
- Beveled corners
- Some additional sizes are available as special order.



Scan for
YouTube video



EDP #56777

EDP #56777 - Huot's handy Accessory tray is great for keeping your constantly needed tools right within hands reach and easily mounts in the existing slots in your Machine Mount Rack. Simply insert the built-in tabs directly into the slots of the rack!

Designed to mount on the front or side of your machine this rack enables you to store and organize toolholders at your fingertips. This small, secure rack increases your efficiency by storing your tools right where you want them.

- Heavy duty construction utilizing a 14 gauge steel base with 16 gauge steel shelves, finished with scratch resistant powder paint
- Low profile keeps shelves close to the machine - only protrudes 11"

EDP#	Description	Capacity
56740	18.25" H x 19" W x 11" D, 19 lbs. 40 taper toolholders	28
56744	CAPTO style C4 tooling	28
56745	CAPTO style C5 tooling	28
56746	CAPTO style C6 tooling	28
56750	CAT 50 toolholders	16
56770	HSK 63A toolholders	28
56780	HSK 100A toolholders	16
Accessories		
56777	Accessory Tray 17.375" W X 10.625" D X 10.5" H, 8 lbs.	

LatheScoat

EDP #77300

Store and organize your turning tooling. You've used Huot ToolScoots for over 25 years to store and organize your milling tooling. What about your turning tooling? Chances are, it's scattered all over the shop. Here's another Huot storage and organization solution to increase your shop's efficiency and profits. This unique product was designed to increase the set up and operating efficiency of any turning machine operation. See our website for more information on our complete line of storage and organization solutions.

- Handy cylindrical bins with belt clips for drills, set up tools or stick tools
- Top drawer utilizes welded columns with dividers for tool organization
- Large 6" deep drawer for storing live tooling heads and other large tools
- Open area for collet chucks, 3 jaw chucks, hard and soft jaws
- Removable top bins store and organize set up tools
- Side tray for optional collet racks, presetters, or miscellaneous items
- Welded frame for rigidity requires no assembly
- Blue and black paint combination differentiates milling and turning Scoots
- Live center shelf holds 3MT and 4MT taper centers by the shank
- Dimensions are 41" L x 35.25" H x 18" D.
- Shipping weight is 92 lbs, LTL only

EDP #77030 Optional Divider Kit for LatheScoat Bins



EDP #77300



Scan for
YouTube video

CNC, V-Flange, CAPTO, VDI, HSK ToolHolders & Collet Platform



EDP #14840

Conveniently holds your CNC toolholders or collets, at the ready, for quick access. Angled platform for 30-35-40-45-50, HSK63A-HSK100A taper tools and 5C or R8 collets. See website for additional sizes.

EDP#	Description	Capacity
14342	QG-42 Angled Platform	24
14365	QG-65 Angled Platform	24
14380	QG-80 Angled Platform	24
14399	QG-100 Angled Platform	24

EDP#	Description	Capacity
14858	20C collets	24
14863	KM63 toolholders	24
14880	HSK63A toolholders	24
14885	HSK100A toolholders	18
14830	30 taper toolholders	24
14835	35 taper toolholders	24
14840	40 taper toolholders	24
14844	HSK40A, 40C, 40E and KM40	24
14845	45 taper toolholders	18
14850	50 taper toolholders	18
14856	5C collets	48
14857	16C collets	50
14866	R8 or #4 morse taper	50
14822	HSK63F	24
EDP#	Collet Bench Top Platforms	Capacity
14824	C4 CAPTO style	24
14825	C5 CAPTO style	24
14826	C6 CAPTO style	24
14828	C8 CAPTO style	18
14833	#30 VDI (not V-flange)	24
14834	#40 VDI (not V-flange)	24

Collet Racks for ER/RD/DR/DA/TG



EDP #14812

- Heavy 14 gauge steel finished with durable epoxy, powder paint.
- Mountable on bench top.
- Protects, stores and organizes your valuable collets.
- Models 14800, 14801, 14802, 14810, 14811 and 14813 fit within 2.0" drawer

EDP#	Description	Hole Size	Capacity
14800	Holds 11 Series Collets ER/RD/DR.	27/64"	49
14801	Holds 16 Series ER/RD/DR	39/64"	49
14802	Holds 20 Series ER/RD/DR	49/64"	36
14810	Holds DA300 Collets	5/16"	49
14811	Holds DA200 Collets	15/32"	49
14813	Holds DA100 Collets	43/64"	36
EDP#	Description	Hole Size	Capacity
14803	Holds 25 Series Collets ER/RD/DR	61/64"	48
14804	Holds 32 Series Collets ER/RD/DR	1-13/64"	40
14805	Holds 40 Series ER/RD/DR	1-1/2"	27
14806	Holds 50 Series Collets ER/RD/DR	2"	21
14812	Holds DA180 Collets	29/32"	48
14820	Holds TG75 Collets	1-1/32"	40
14821	Holds TG100 Collets	1-5/16"	27
14822	Holds TG150 Collets	1-59/64"	21

Larger Collet Racks for ER/RD/DR/DA/TG

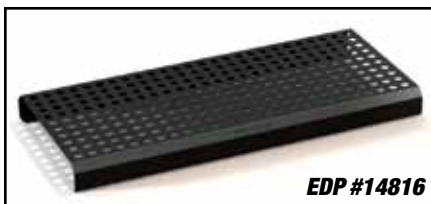

EDP #14816

EDP#	Description	Hole Size	Capacity
14816	ER16, 1" x 1" spacing	39/64"	260
14817	ER20, 1-3/16" x 1-1/4" spacing	49/64"	176
14818	ER25, 1-3/8" x 1-5/8" spacing	61/64"	114
14819	ER32, 1-21/32" x 1-3/4" spacing	1-13/64"	90
14827	TG100, 1-7/8" x 2" spacing	1-5/16"	70

New larger collet racks fit perfectly in the utility tray of the ToolScoot Tree on pages 5, 6 & 7 or can be used on a workbench as well.

V-Flange and HSK NC Racks



EDP #14728

- Holds NC Toolholders, Collets and Tap Adapters
- Angled for easier selection of stored tools.
- Mounts on bench top or fits neatly inside standard 36" industrial cabinet.
- Heavy gauge steel with epoxy powder finish

EDP#	Description 12.5" W x 16.5" D x 6.75" H	Weight
14725	40 Taper NC rack has 12 spaces for toolholders, 7 spaces for Tap Drivers or DA-180 Series Collets, 8 spaces for DA-180 Series, 10 spaces for DA-200 Series, 9 spaces for DA-300 Series.	5.5 lbs.
14728	40 Taper NC Tool Holder has 12 spaces for each of the following: 40 taper toolholders, ER16 Collets and ER32 Collets.	5.5 lbs.
14730	30 Taper NC Tool Holder has 12 spaces for toolholders, 7 spaces for Tap Drivers or DA-180 Series Collets, 8 spaces for DA-180 Series, 10 spaces for DA-200 Series, 9 spaces for DA-300 Series.	5.5 lbs.

CNC, HSK Tool Tote Rack for 40 and 50 Taper



EDP #14790

EDP#	Description 28.75" L x 5.25" W x 6" H, 6 lbs	Capacity
14765	30 taper tools	6
14780	40 taper tools	6
14790	50 taper tools	5
14770	HSK 63A	6
14775	HSK 100A	5

- Bench mount, hand carry, or mount on top of your shop cart.
- Heavy gauge steel with molded inserts to help protect your tooling
- Built-in handles for comfortable carrying
- Painted texture black with pollution free powder coating process.

5C, R8 Collet Racks

- Angled for visibility and easier selection of stored collets.
- Mountable on bench top.
- Tough, solvent free, epoxy finish Ecolo-Clad for long lasting protection.
- Heavy gauge steel.

EDP #14600 Holds up to 30 pieces 5C Collets.

Dimensions: Top 9" W x 12" D.

Weight: 3 lbs.

EDP #14625 Holds up to 17 R8 Collets.

Dimensions: Top 5 1/4" W x 9" D.

Weight: 2 lbs.



EDP #14600

Mountable to milling machine



EDP #14625

Machine or Wall Mount CNC ToolHolder Racks



EDP #14776

- Mounts on the CNC machine or on a wall in any handy location.

EDP#	Description 24" W x 5" L x 4.875" H, 7 lbs	Cap.
14763	KM63 toolholders	7
14771	40 taper V-flange CNC toolholders	7
14776	50 taper V-flange CNC toolholders	5
14777	30 taper toolholders	7
14781	HSK 63A CNC toolholders	7
14791	HSK 100A CNC toolholders	5
14784	CAPTO C4	7
14785	CAPTO C5	7
14786	CAPTO C6	7

Shop Tower

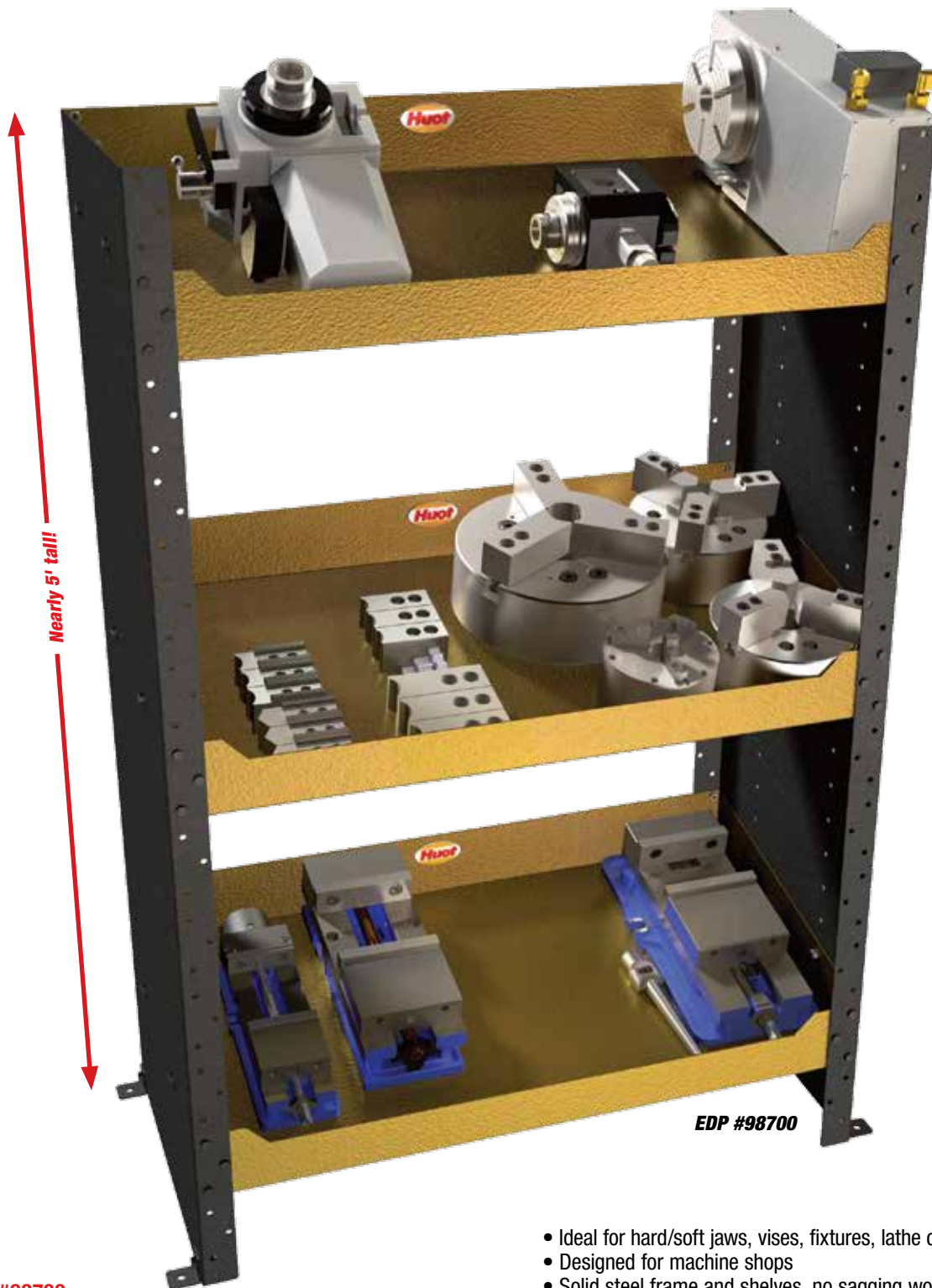

EDP #98700

EDP #98700

- 12 gauge cold roll steel construction
- 5/16" hardware provided for assembly
- Shelf tub depth is 4" on 3 sides with front notched to 2-5/8"
- Open design, stored products are easily visible
- Top shelf offers easy crane access
- Adjustable shelf heights. 12 possible locations.
- Shelves mount at a -13° angle
- Compact design fits in machining cell
- Universal design accommodates multiple types of tooling

- Ideal for hard/soft jaws, vises, fixtures, lathe chucks, tooling heads
- Designed for machine shops
- Solid steel frame and shelves, no sagging wood or mesh bottoms
- Ergonomic height allows for easy lifting of components
- Just what you need to achieve your 5S and/or Lean 6 Sigma initiatives
- Tabs on legs allow for bolting to shop floor for additional stability & safety
- Overall dimensions are 39.25" Wide X 20" Deep X 59.5" Tall
- Precision engineering makes for fast assembly
- Proudly made in the USA

Quick Grip Collet Solutions

Our TriScoot and Angled Platform provide the ideal place to store your Quick Grip collets. These sturdy American made shop accessories can substantially reduce your set up times. They make an excellent addition to your machine cell and will provide value for decades. Our TriScoot is constructed of 16 gauge steel with three flat shelves for maximum capacity. Fixed and locking/swivel casters make it easy to move from machine to machine. Our Angled Platform is constructed from cold rolled steel. Shelves at 13° angle to present tools. Stationary table top 13 design. Stores collets right where you need them.



EDP #14342

EDP#	Description	Cap.
14342	#42 Quick grip collet Angled Platform	18
14365	#65 Quick grip collet Angled Platform	15
14380	#80 Quick grip collet Angled Platform	13
14399	#100 Quick grip collet Angled Platform	10
EDP#	Tree Shelf Description	Cap.
55242	QG-42 Tree Shelf	17
55265	QG-65 Tree Shelf	12
55280	QG-80 Tree Shelf	8
55299	QG-100 Tree Shelf	6

Huot Tree Shelves can be ordered for ToolScoot Trees and Lockers as shown on pages 6, 7 and 13.



EDP #77342

EDP#	TriScoot Description	Cap.
77342	#42 Quick grip collet TriScoot	54
77365	#65 Quick grip collet TriScoot	45
77380	#80 Quick grip collet TriScoot	39
77399	#100 Quick grip collet TriScoot	30



EDP #55242



EDP #55265



EDP #55280



EDP #55299

Original Series

Most Original Series Dispensers Feature:

- Original series are as the name implies, the first style of dispensers that Huot created.
- Most models are 3, 4 or 5 drawers and weigh between 10 and 14 pounds.
- All models measure 14-5/8" W x 7-5/8" D x 7-3/4" H and utilize a compound type slide.
- Holds full packages of each size (12 pc. min.).
- Stackable for larger inventories.
- 4 indents on the top and 4 protrusions on the bottom to make stacking easier.
- One piece drawer slide for long useful life.
- Decimal equivalents.



Drill Dispensers, Original

- EDP #13000** Fractional drills 1/16" to 1/2" by 64ths. Weight 10 1/4 lbs.
- EDP #13025** Drills #1 to #60 Wire Gauge. Weight 13 1/4 lbs.
- EDP #13050** Drills A to Z letter size. Weight 10 1/4 lbs.
- EDP #13075** Drills 1mm to 13mm by 0.5mm. Weight 10 1/4 lbs.
- EDP #13100** Drills 1mm to 6.9mm by 0.1mm. Weight 13 3/4 lbs.
- EDP #13040** Drills #1 to #80 Wire Gauge. Weight 13 3/4 lbs.

Stub/Screw Machine Dispensers

- EDP #13015** Stub drills 1/16" to 1/2" x 64ths, 10 1/4 lbs. each
- EDP #13030** Stub drills 1-60, 13 1/4 lbs. each
- EDP #13060** Stub drills A-Z, 10 1/4 lbs. each
- EDP #13080** Stub drills 1mm-13mm x 0.5mm, 10 1/4 lbs. each
- EDP #13090** Stub drills 1mm-6.9mm x 0.1mm, 13 3/4 lbs. each

Silver Deming, Original

- EDP #13166** Holds 2 each reduced shank S/D bits from 33/64ths to 63/64ths by 64ths
Dimensions: 14-5/8" W x 7-3/8" D x 7-3/4" H.
Weight: 13-1/4 lbs.
- EDP #13167** Holds 2 each reduced shank S/D bits 1", 1-1/32, 1-1/16, 1-1/8, 1-5/32, 1-3/16, 1-1/4, 1-5/16, 1-3/8, 1-7/16, 1-1/2 • **Weight:** 10-3/4 lbs.

Master Series

Master Drill Dispensers Feature:

- Ball bearing drawer slides
- Lockable with built in cam lock and comes with two keys.
- Each drawer measures 23.125" wide; 11" front to back.
- 4 stacking clips mate with slots in the top of each Master. This makes stacking of dispensers a breeze.
- All steel cabinet with vinyl dividers helps protect and separate bits.



Scan for YouTube video



Drill Dispensers, Master

EDP #13175 • Drills, Fractional, Letter, Wire, Standard, All-In-One

Holds full packages (minimum of 12 pcs.) of jobber or screw machine length drills, fractional, letter and wire gauge sizes in one complete cabinet.

- Top drawer holds fractional drills 1/16" to 1/2" by 64th with 42 comp.
- 2nd drawer is for #1 to #60 wire gauge with 75 compartments.
- 3rd drawer for letter size A to Z with 42 compartments.
- Drawer Divider Kits available for lower drawer, see page 23.

Scan QR code for detail including drawer configuration photos.



EDP #13085

Holds metric drill bits from 1 mm to 25 mm x 0.5 mm.

Scan QR code for detail including drawer configuration photos.



EDP #13180

Holds metric drills from .35mm to 13.00mm. Sizes include: .35mm to 2.50mm by .05mm, 2.6mm to 10.0mm by .1mm, 10.2mm, 10.5mm, 10.8mm, 11.0mm, 11.2mm, 11.5mm, 11.8mm, 12.0mm, 12.2mm, 12.5mm, and 13.0mm.

138 compartments to store and inventory all your metric drill bits. Same great features as our #13175 jobbers length master cabinet.

Dimensions: 26" W x 12" D x 12 1/2" H.

Weight: 50 lbs.

Scan QR code for detail including drawer configuration photos.



EDP #13190 • Drills, Fractional, Letter, Wire, Metric, All-In-One

Cabinet holds fractional drills 1/16" to 1/2" by 64ths, 1 to 60 wire gauge, A to Z letter sizes and metric from 0.35mm to 13.00mm including 0.35mm to 2.50mm x .05mm, 2.6mm to 10.0mm x .1mm, and 10.2, 10.5, 10.8, 11.0, 11.2, 11.5, 11.8, 12.0, 12.2, 12.5, 13.0mm. Will hold a minimum of full packages of each size.

Scan QR code for detail including drawer configuration photos.



Tap Dispenser, Original



EDP #13500

EDP #13500

1/4"-20NC 1/4"-28NF 5/16"-18NC 5/16"-24NF
 3/8"-16NC 3/8"-24NF 7/16"-14NC 7/16"-20NF
 1/2"-13NC 1/2"-20NF 9/16"-12NC 9/16"-18NF
 5/8"-11NC 5/8"-18NF 3/4"-10NC 3/4"-16NF
 7/8"-9NC 7/8"-14NF 1"-8NC 1"-12NF

Weight: 10 1/2 lbs.

EDP #13550

Holds taper, plug, bottoming, and spiral point taps.
 60 compartments. Holds machine screw sizes:

2-56 3-48 3-56 4-40 4-48 5-40
 5-44 6-32 6-40 8-32 8-36 10-24
 10-32 12-24 12-28

Weight: 13 lbs.

EDP #13575

Holds 29 popular metric sizes:

3mm x .50 3mm x .60 4mm x .70
 4mm x .75 5mm x .80 5mm x .90
 6mm x 1.00 6.3mm x 1.00 7mm x 1.00
 8mm x 1.00 8mm x 1.25 9mm x .75
 9mm x 1.00 9mm x 1.25 10mm x 1.00
 10mm x 1.25 10mm x 1.50 11mm x 1.50
 12mm x 1.25 12mm x 1.50 12 mm x 1.75
 14mm x 1.25 14mm x 1.50 14mm x 2.00
 16mm x 1.50 16mm x 2.00 18 mm x 2.50
 20mm x 2.50 24mm x 3.00

Weight: 10 1/2 lbs.

National Pipe Tap Dispenser

EDP #13560

Top drawer has 13 compartments

Holds NPT from 1/16" to 2"
 Two for 1/16" - 27, Two for 1/8" - 27
 Three for 1/4" - 18, Three for 3/8" - 18
 Three for 1/2" - 14

Middle drawer has 6 compartments

Three for 3/4" - 14, Two for 1" - 11-1/2
 One oversized for 1-1/4" - 11-1/2

Bottom drawer has 2 oversized compartments

One for 1-1/2" - 11-1/2, One for 2" - 11-1/2

Dimensions: 14-5/8" W x 7-3/8" D x 7-3/4"H

Weight: 10-1/4 lbs.

Phosphate pretreatment and finished in Huot's battleship gray powder coating for good looking inventory control and long useful life.

Tap Dispensers, Master

EDP #13700 • Metric Drills, End Mills, Reamers, All-In-One

Metric - 4 in 1 Combination Dispenser

Drills-Metric .35mm to 2.5mm x .05mm, 2.6mm to 10mm x .1 and additional common sizes up to 13mm.

End Mills-Metric 2.0 to 7.0 x .5 and 8.0, 9.0, 10.0, 11.0, 12.0, 12.5, 13.0mm

Taps - 31 of most commonly used taps from 2.5mm x .45 to 30mm x 3.50mm

Reamers-Metric 1.0mm to 13.0mm x .5

Both models are 6 drawer cabinets measuring 26" W by 12" D by 15 13/16" H and ship at 80 lbs. Must ship via LTL, not via UPS. Drawers measure 23 1/8" W x 11" D x 2" H. Equipped with smooth ball bearing drawer slides. Weight 80 lbs.

Scan QR code for detail including drawer configuration photos.



EDP #13585

- Holds most common NC/NF sizes from 1/4" to 1-1/2".
- Holds metrics from 2.5 mm to 30 mm.
- Holds machine screw size 2-56 thru 12-28, taper, plug, bottom and spiral.
- Extruded vinyl drawer dividers protect taps.
- Top drawer has 40 compartments.
- Second drawer has 78 compartments.
- Third drawer has 21 compartments.
- Fourth drawer has 13 compartments.
- Stackable for larger inventories.
- Lockable.
- Ball bearing drawer slides.

Scan QR code for detail including drawer configuration photos.

Dimensions: 26" W x 12" D x 12 1/2" H. **Weight:** 50 lbs.



EDP #13580

- For sizes 1/4"-20 to 1"-14 taps
- Holds bottom, plug and taper of each size:
 1/4"-20 1/4"-28 5/16"-18 5/16"-24 3/8"-16 3/8"-24 7/16"-14 7/16"-20
 1/2"-13 1/2"-20 9/16"-12 9/16"-18 5/8"-11 5/8"-18 3/4"-10 3/4"-16
 7/8"-9 7/8"-14 1"-8 1"-14

- Holds taper, plug, bottom and spiral:

2-56 3-48 3-56 4-40 4-48 5-40 5-44
 6-32 6-40 8-32 8-36 10-24 10-32 12-24 12-28

Scan QR code for detail including drawer configuration photos.

Dimensions: 26" W x 12" D x 12.5" H. **Weight:** 50 lbs.



Taper Shank & Length Drill Dispenser

EDP #13185

- Conveniently stores Taper Length or Taper Shank Drills from 1/8" to 1" by 64ths.
- Vinyl drawer dividers separate and protect drills.
- Drawer dimensions: 23-1/8" L x 11" W (front to back).
- Stackable with other dispensers.
- Built-in cam lock with two keys.
- Equipped with smooth ball bearing drawer slides.

Scan QR code for detail including drawer configuration photos.

Dimensions: 26" W x 12" D x 12.5" H. **Weight:** 50 lbs.



Tap and Drill Dispenser, Original



EDP #13590

- Stores and organizes correct drill with corresponding size Tap.
- Holds approximately 1 dozen (min.) of each size.

TAP	DRILL	TAP	DRILL
6 - 32	#36	5/16 - 24	I
8 - 32	#29	3/8 - 16	5/16
10 - 24	#25	3/8 - 24	Q
10 - 32	#21	7/16 - 14	U
1/4 - 20	#7	7/16 - 20	25/64
1/4 - 28	#3	1/2 - 13	27/64
5/16 - 18	F	1/2 - 20	29/64

Weight: 10½ lbs.

Metric Taps, Drills & Dies



EDP #13595

Holds Metric taps, drill and dies. From 2.5 x .45 tap to 12.0 x 1.75 tap and holds the following sizes:

Top drawer: 2.5 x .45 tap - 2.05 drill, dies
 3.0 x .50 tap - 2.50 drill, dies
 3.5 x .60 tap - 2.90 drill, dies
 4.0 x .70 tap - 3.30 drill, dies

Middle drawer: 5.0 x .80 tap - 4.20 drill, dies
 6.0 x 1.0 tap - 5.00 drill, dies
 8.0 x 1.25 tap - 6.70 drill, dies

Bottom drawer: 10.0 x 1.50 tap - 8.50 drill, dies
 12.0 x 1.75 tap - 10.20 drill, dies

Weight: 10.25 lbs.

Phosphate pretreatment and finished in Huot's battleship gray powder coating for good looking inventory control and long useful life.

Counterbore Dispenser, Original

EDP #13570 Holds continuous pilot counterbores 4, 5, 6, 8, 10, 12, 1/4, 5/16, 3/8, 7/16 & 1/2"
Weight: 14 lbs.

Silver Deming, Master

EDP #13165

Cabinet holds the following Silver Deming drills:

33/64ths to 1" by 64ths, as well as 1-1/32", 1-1/16", 1-1/8", 1-3/16", 1-1/4", 1-3/8", 1-1/2".

- Lockable dispenser contains a total of 110 compartments.
- 103 identified for each size Silver Deming drill.
- An additional 7 compartments for specialized requirements.
- Equipped with smooth ball bearing drawer slides.
- Drawers measure 23.125" W x 11" D x 2" H.

Dimensions for 6 drawer cabinet: 26" W x 12" D x 15-13/16" H.

Weight: 80 lbs., must ship via LTL, not via UPS.

Scan QR code for detail including drawer configuration photos.



Tap & Drill Dispensers, Master

EDP #13597

Holds Tap & Drill sizes #0-80 3/64 to 1.5-12 1-27/64

- Conveniently holds tap with the corresponding tap drill. No wasted time looking for proper sizes as they'll be right at your fingertips.
- Holds approximately one dozen each of the smaller sizes and at least several of each of the larger sizes.
- Built in cam lock with two keys.
- Heavy duty ball-bearing drawer slides for easy use and long service life.

Scan QR code for detail including drawer configuration photos.

Dimensions: 26" L x 12" W x 12.5" H. **Weight:** 50 pounds.



EDP #13599

Same great features as above model but for metric taps and drills. M1.6x0.35 1.25mm to M24x2.0 22.00mm

Dimensions: 26" L x 12" W x 12.5" H. **Weight:** 50 pounds.

Scan QR code for detail including drawer configuration photos.



End Mill Dispenser



EDP #13350

EDP #13350

For Small Inventories

- 1 Compartment for 9/16", 11/16", 7/8"
- 2 Compartments for 3/16", 5/16", 7/16", 5/8", 1"
- 3 Compartments for 1/8", 1/4", 3/8", 3/4"
- 4 Compartments for 1/2"

Weight: 10.25 lbs.

Carbide Burr Dispenser

EDP #13200

Holds these sizes:

Cylindrical 1/4" x 5/8"	Cyl. Rad. End 1/4" x 5/8"
Ball 1/4" x 1/4"	Oval 1/4" x 3/8"
Tree Rad. 1/4" x 3/4"	Tree/Pointed 1/4" x 3/4"
Cone/Rad. End 1/4" x 5/8"	Cylindrical 3/8" x 3/4"
Cyl./Rad. End 3/8" x 3/4"	Ball 3/8"
Oval 3/8" x 5/8"	Tree/Rad. End 3/8" x 3/4"
Tree/Pointed 3/8" x 3/4"	Cone/Rad. End 3/8" x 1-1/16"
Cone/Flat End 1/4" x 1"	Cone/Rad. End 1/2" x 1-1/8"
Cone/Flat End 3/8" x 1"	Cylindrical 1/2" x 1"
Cyl./Rad. End 1/2" x 1"	Ball 1/2"
Oval 1/2" x 7/8"	Tree/Rad. End 1/2" x 1"
Tree/Pointed 1/2" x 1"	Cone/Flat End 1/2" x 1"

Weight: 10 1/2 lbs.

Reamer Cabinets, Dispenser

- 4 models for reamer organization.
- Ideal where compact space is a must.
- Decimal equivalents also listed.

EDP #13410

Fractional Reamers 1/16" to 1/2" by 64ths, Weighs 13 lbs.-4 drawers.

EDP #13415

A to Z Reamers
Weighs 13 lbs.-3 drawers.

EDP #13420

Wire gauge sizes #1 to #60,
Weighs 14 lbs.-5 drawers.

EDP #13425

Metric reamer dispenser holds 1mm to 13mm x 0.5mm. Weighs 14 lbs

EDP #13430

Combination cabinet for over/under and dowel pin sizes, Weighs 11 lbs.-3 drawers.

2 or 4 Flute & Metric End Mill Dispensers

EDP #13300

For 2-Flute End Mills, popular sizes 1/16" to 1" fractional. Lockable and stackable.

Scan QR code for detail including drawer configuration photos.



EDP #13325

For 4-Flute End Mills, popular sizes 1/16" to 1" fractional. Lockable and stackable.

Scan QR code for detail including drawer configuration photos.



EDP #13375

Metric end mills are separated and identified from 2.0mm to 25.0mm. 68 pre-labeled compartments help you quickly locate the proper cutting tool. Holds the following metric end mills: 2.0mm 2.5mm 3.0mm 3.5mm 4.0mm 4.5mm 5.0mm 5.5mm 6.0mm 7.0mm 8.0mm 9.00mm, 10.0mm 11.0mm 12.0mm 12.5mm 13.0mm 14.0mm 15.0mm 16.0mm 17.0mm 18.0mm 19.0mm 20.0mm 21.0mm 22.0mm 23.0mm 24.0mm 25.00mm

Top Drawer 41 Compartments (13300 & 13325)

Holds 6 each single end fractional end mills in following sizes: 1/8", 3/16", 1/4", 5/16", 3/8", 7/16" and 1/2". 3 each 5/8", 3/4", 7/8", and 1" with 6 extra compartments for specials.

Middle Drawer 41 Compartments

Holds 6 each double end fractional end mills in following sizes: 1/16", 3/32", 1/8" with 3/16" shank, 1/8" with 3/8" shank, 3/16", 3/16" with 3/16" shank, 3/16" with 3/8" shank, 1/4", 3/16", 3/8", 7/16" and 1/2". 3 each 5/8", 3/4", 7/8" and 1".

Lower Drawer Undivided

Use for extra end mills, cutters, drills, reamers and miscellaneous tools.

See page 23 for Optional Drawer Divider Kit #14030.

Dimensions: All models 26" W x 12" D x 9 5/16" H.

Each drawer measures 23 1/8" W x 11" D x 2" H.

Each drawer with ball bearing slides.

Weight: 40 lbs. ea.

Scan QR code for detail including drawer configuration photos.



Reamer Cabinets, Dispenser

EDP #13400

• Stores following reamers:

1/8"-4 ea., .1230 d/p, .1240 under, .1247 d/p, .1260 over, 3 ea. 3/16", .1855 d/p, .1865 under, .1870 d/p, .1885 over, 3 ea. 1/4"-4 ea., .2480 d/p, .2490 under, .2495 d/p, .2510 over, 3 ea. 5/16"-3 ea., .3105 d/p-3 ea., .3115 under 2 ea., .3120 d/p-2 ea., .3135 over-2 ea. 3/8"-4 ea., .3730 d/p, .3740 under, .3745 d/p, .3760 over, 3 ea. 7/16", .4355 d/p, .4365 under, .4370 d/p, .4385 over, 2 ea. 1/2"-4 ea., .4980 d/p-2 ea., .4990 under, .4995 d/p, .5010 over, 3 ea.

• Lockable, Stackable.

• Ball bearing drawer slides.

Dimensions: 26" W x 12" D x 9 5/16" H. **Weight:** 40 lbs.

Scan QR code for detail including drawer configuration photos.



EDP #13450

Fractional Reamers 1/16" to 1/2"

Over/Under Reamers from .1240 to .5010

Dowel Pin Reamers from .1230 to .4995

Metric Reamers from 1.0mm to 13.0mm x .5

Dimensions: 26" W x 12" D x 12.5" H. **Weight:** 50 lbs.

Scan QR code for detail including drawer configuration photos.



Insert Dispenser



EDP #13650

EDP #13650

- Designed to keep inserts at each work center.
- Compact size and affordable price lets the user keep the most frequently used inserts within fingertip reach.
- Three drawers have a moveable divider with a large fourth drawer to store tool holders and extra inserts.
- Label holders on drawer fronts permit easy, quick identification and inventory check.
- Stackable with other cutting tool storage cabinets to save space.

Weight: 13 lbs.

Master Dispenser Stands

Master Dispenser Stands are more ergonomic. Instead of taking up valuable space on that bench top, this stand allows you to put your cutting tools next to the bench, not on it.

- Our Master Dispensers fit easily and securely in the top
- Cold rolled steel construction
- Ergonomic position reduces bending
- Black texture powder coat finish
- A safe and efficient addition to any shop
- Available in 12" or 26" heights
- Adjustable feet allow for leveling
- Assembles in minutes



EDP #13333

Insert Dispenser Master



EDP #13600

EDP #13600

- Holds Square, Triangular, Diamond and Round Inserts, with additional space for Specials.
- 36 Compartments to hold packages or loose inserts. Measures 3-3/4" W x 5-1/2" D.
- Pre-labeled for insert shape.
- Label set included for your personalized marking of size, radius, grind and thickness.
- Lockable and comes with set of two keys.
- Stackable with other dispensers.
- Ball bearing drawer slides.

Dimensions: 26" W x 12" D x 12.5" H. **Weight:** 50 lbs.

Scan QR code for detail including drawer configuration photos.



Universal Master Dispenser



EDP #13174

- Full extension ball bearing slides with posi-lock catch.
- 72 movable dividers included.
- 3 drawers are divided, bottom drawer is open for larger tools.
- Key lock on all Master models.
- Steel construction

Dimensions: 12" W x 12" D x 12.5" H.

Weight: 50 lbs.

Super Chest and Super Cabinet

- Solid welded drawer dividers front to back provide a rigid smooth surface with no holes to lose parts.
- 24,000 combined cubic inches of usable storage space.
- Heavy duty cam lock and hidden locking mechanism.
- Rugged, exclusive I-beam doublewall construction.
- 18 gauge, all steel construction with Huot's Ecolo-Clad plastic paint. Environmentally safe finish.
- Steel skid keeps unit off floor and allows for stacking for even greater space savings.
- Stackable. Two high maximum.
- Label holders provide identification at a glance.
- Each drawer rigidly constructed of solid steel with no holes in drawer bottom to keep small parts inside of drawer. Will hold 150 lbs. supported on full extension ball bearings slides.
- Deeper drawers available.

EDP #13530

Super chest with 8 drawer capacity.
240 individual drawer dividers included.

Dimensions: 34" W x 19 $\frac{1}{8}$ " D x 23 $\frac{1}{8}$ " H.

Weight: 220 lbs.

EDP #13525

Super cabinet with 15 drawer capacity.
480 individual drawer dividers included.

Dimensions: 34" W x 19 $\frac{1}{8}$ " D x 38" H.

Each drawer measures 29" W x 18" D x 2" H.

Weight: 375 lbs.



Scan for
YouTube video



**EDP #13530
Super Chest
stacked on
EDP #13525
Super Cabinet**



EDP #13527



**No holes in
drawer bottom**

**3/4"
wide**

**Front to back dividers
welded into position**

**Metal drawer divider
Kit #8755**

EDP #13527

Super cabinet with 8 drawer capacity.
7 drawers 4" high, 1 drawer 2" high.

480 individual drawer dividers provided.

Dimensions: 34" W x 19 $\frac{1}{8}$ " D x 38" H.

Each drawer measures 29" W x 18" D x 2" H.

Weight: 375 lbs.

**Huot Mfg. Co. does not manufacture or
distribute cutting tools of any type.
Cutting tools shown in all photos are
for display purposes only.**

Drill Indexes/U.S.

EDP #12750

For jobbers length fractional drills $\frac{1}{16}$ " to $\frac{1}{4}$ " inclusive by 64ths.

Dimensions: 4" W x 5 $\frac{3}{8}$ " D x $\frac{5}{16}$ " H.

EDP #10350

For jobbers length fractional drills $\frac{1}{16}$ " to $\frac{1}{2}$ " inclusive by 32nds.

Dimensions: 4" W x 7" D x 1 $\frac{1}{4}$ " H.

EDP #10400

For wire gauge drills No. 61 to 80.

Dimensions: 1 $\frac{1}{2}$ " W x 2" D x $\frac{9}{32}$ " H.

EDP #10450

For jobbers length fractional drills $\frac{1}{16}$ " to $\frac{3}{8}$ " inclusive by 64ths.

Dimensions: 4" W x 6" D x 1 $\frac{1}{8}$ " H.

EDP #10500

For letter size drills A to Z inclusive.

Dimensions: 4" W x 7" D x 1 $\frac{3}{4}$ " H.

EDP #10550

For jobbers length fractional drills $\frac{1}{16}$ " to $\frac{1}{2}$ " by 64ths inclusive. Decimal equivalents and U.S.S. tap information included.

Dimensions: 4" W x 7" D x 1 $\frac{3}{4}$ " H.



EDP #12750

EDP #10600

For wire gauge drills #1 to #60 inclusive. Decimal equivalents and machine screw tap information included.

Dimensions: 3 $\frac{1}{4}$ " W x 4 $\frac{1}{2}$ " D x 1" H.

EDP #10700

For wire gauge drills 1 to 80 inclusive.

Dimensions: 3 $\frac{1}{4}$ " W x 4 $\frac{1}{2}$ " D x $\frac{15}{16}$ " H.

EDP #10800

For jobbers length fractional drills $\frac{1}{64}$ " to $\frac{1}{4}$ " by 64ths.

Dimensions: 4" W x 5 $\frac{3}{8}$ " D x $\frac{5}{16}$ " H.

EDP #12300

For $\frac{1}{16}$ " to $\frac{1}{4}$ " by 64ths and $\frac{3}{32}$ " to $\frac{1}{2}$ " by 32nds, jobbers length.

Dimensions: 4" W x 7" D x 1 $\frac{1}{4}$ " H.

EDP #10875

Maintenance Index

19 piece index holds every drill needed for frequent maintenance work in one handy index case. Holds $\frac{1}{16}$ ", $\frac{5}{64}$ ", $\frac{3}{32}$ ", $\frac{1}{8}$ ", #29, #25, $\frac{5}{32}$ ", #21, $\frac{3}{16}$ ", #7, $\frac{7}{32}$ ", $\frac{1}{4}$ ", #F, $\frac{5}{16}$ ", #U, $\frac{3}{8}$ ", $\frac{27}{64}$ ", $\frac{7}{16}$ ", $\frac{1}{2}$ ".

Dimensions: 4" W x 7" D x 1 $\frac{1}{4}$ " H.

EDP #11655

Holds 6" OAL aircraft extension bits from 1/16" to $\frac{1}{2}$ " by 64ths.

Dimensions: 4" W x 2" D x 8 $\frac{3}{4}$ " H.

Weight: 1.5 pounds.

EDP #15235

Holds jobber length drills $\frac{1}{8}$ ", $\frac{3}{16}$ ", $\frac{1}{4}$ ", $\frac{5}{16}$ ", $\frac{3}{8}$ ", $\frac{7}{16}$ ", $\frac{1}{2}$ ".

Dimensions: 4" W x 7" D x 1 $\frac{1}{4}$ " H.

For metric sizes see page 26

Screw Extractor & Drill Index

EDP #10200

Holds #1, #2, #3, #4, #5 screw extractor and corresponding size drill bit.

Dimensions: 4" W x 5-1/2" D x 1/2" H.

EDP #10200



Reamer Cases

These handy, all-steel reamer cases are designed to hold the reamer securely by the shank to help protect delicate cutting edges. Indexed for reamer size in decimal equivalents, with raised embossed lettering for permanent identification.

EDP #12100

Over and Under sizes .124 - .126 to .499-.501 by 16ths. Holds 14 reamers.

Dimensions: 4" W x 8-5/18" D x 13/16" H.

EDP #12125

For dowel pin reamers .123 to .4995.

Holds 14 reamers.

Dimensions: 4" W x 8-5/8" D x 13/16" H.



EDP #12050

EDP #12000

A to Z reamers.

Dimensions: 4" W x 8-5/8" D x 1-13/16" H.

EDP #12050

Chucking reamers 1/16" to 1/2" by 64ths.

Dimensions: 4" W x 8-5/8" D x 1-13/16" H.

EDP #12200

No.1 to 60 inclusive.

Dimensions: 3-3/8" W x 6-3/4" D x 13/16" H.

EDP #12130

For metric reamers 1.00mm to 13.00mm by 0.5mm. Holds 25 reamers in an all steel case with easy to read mylar identification labels to pick the right size quickly and easily.

Dimensions: 8-3/4" W x 4"D x 1-3/4"H.

Bit Buddy

Bit Buddy is all plastic, break resistant and water resistant, durable and holds Jobbers length or Mechanics length drill bits.

EDP #30550

For Jobbers length drills 1/16" to 1/2" by 64ths.

EDP #30650

For Mechanics length drills 1/16" to 1/2" by 64ths.

Huot Mfg. Co. does not manufacture or distribute cutting tools of any type. Cutting tools shown in all photos are for display purposes only.

Custom colors available in 1,000 piece minimum.



EDP #30550



Combination Indexes



EDP #11700

EDP #11700

Holds 115 drills-29 fractional, 26 letter and 60 wire gauge; 1/16" to 1/2" by 64ths, 1 to 60, A to Z letter size. (Stub version EDP #11550 available see page 27).

EDP #11750

Same features as Model #115 above but includes the #61-80 wire gauge sizes in one complete index. Holds 135 drills.

EDP #11800

Holds 134 drills-29 fractional, #80 wire gauge and 25 metric; 1/16" to 1/2" by 64ths #1 to #80 wire gauge, 1mm to 13mm by 0.5mm.

Dimensions: 13 1/2" W x 4 5/8" D x 2 1/4" H.

Weight: 4 lbs.

Ideal for keeping all of the most commonly used drills handy. Holds up to 135 drills in one combination case. Indexed for size and decimal equivalents.

EDP #11825

Holds 118 most popular metric bits from 1.0mm to 13.0mm. See metric indexes below for full description.

Dimensions: 13 5/16" L x 4 1/2" W x 2 3/4" H.

Weight: 4 lbs.

EDP #11550

Holds 115 stub screw machine length drills in one case. For stub drills 1/16" to 1/2" by 64ths, 1 to 60 wire gauge and A to Z letter size.

Dimensions: 13 1/2" W x 4 5/8" D x 2 1/4" H.

Drill Indexes/Metric

EDP #11825

Holds 118 most popular metric bits from 1.0mm to 13.0mm. Sizes include:

- 1.00mm to 2.50mm by .05mm
- 2.6mm to 10.0mm by .1mm
- 10.2mm 10.5mm 10.8mm
- 11.0mm 11.2mm 11.5mm
- 11.8mm 12.0mm 12.2mm
- 12.5mm 12.8mm 13.0mm

U.S. decimal equivalents are given for each size drill.

Dimensions: 13 5/16" L x 4 1/2" W x 2 3/4" H.

Weight: 4 lbs.

EDP #11000

1mm to 6mm inclusive by 0.5mm

Dimensions: 4" W x 5 1/2" D x 1 1/2" H.

EDP #11050

1mm to 7mm inclusive by 0.5mm

Dimensions: 4" W x 5 1/2" D x 1 1/2" H.



EDP #11825

EDP #11100

1mm to 10mm by 0.5mm inclusive.

Dimensions: 4" W x 6" D x 1 1/8" H.

EDP #11150

1mm to 13mm by 0.5mm inclusive.

Dimensions: 4" W x 7" D x 1 3/4" H.

EDP #11200

6mm to 10mm by 0.1mm inclusive.

Dimensions: 4 1/2" W x 7 1/8" D x 2 1/2" H.

EDP #11250

1mm to 5.9mm by 0.1mm inclusive.

Dimensions: 3 3/4" W x 4 1/2" D x 1" H.

Silver Deming

EDP #10760

For drills: 9/16" to 1" by 16ths. Holds eight S/D drills securely by the 1/2" shank.

Dimensions: 8½" L x 6¼" W x 2" H.

Weight: 2½ lbs.

(See page 28 for S/D stand)



EDP #10760

Three index cases to complete S/D drills from 1/2" to 1" by 64ths

EDP #10761

15 S/D drills 1/2" to 23/32" by 64ths

EDP #10762

10 S/D drills 47/64" to 7/8" by 64ths

EDP #10763

8 S/D drills 57/64" to 1" by 64ths

Dimensions: 8½" L x 6¼" W x 2" H.

Weight: 2½ lbs.

Taper Shank/Taper Length

EDP #10900

For Morse taper shank and taper length straight shank drills 33/64" to 3/4" by 64ths.

Dimensions: 5½" W x 12½" D x 3⅝" H.

EDP #10950

For Morse taper shank and taper length straight shank drills 49/64" to 1" by 64ths.

Dimensions: 6⅝" W x 15½" D x 3⅝" H.



EDP #10900

EDP #11525

A to Z letter size taper length.

Dimensions: 8¾" W x 4" D x 1¼" H.

EDP #11600

1/16" to 1/2" by 64ths taper length.

Dimensions: 8¾" W x 4" D x 1¼" H.

EDP #11650

1 to 60 wire gauge taper length.

Dimensions: 6¾" W x 3½" D x 1¼" H.

Stub Screw Machine Indexes

EDP #11300

Index for stub screw machine length fractional drills 1/16" to 1/4" by 64ths.

Dimensions: 4" W x 5⅝" D x ⅝" H.

EDP #11350

Index for stub screw machine length fractional drills 1/16" to 3/8" by 64ths.

Dimensions: 4" W x 4⅝" D x ⅝" H.

EDP #11375

For metric stub drills 1 to 13 mm by 0.5 mm. Decimal equivalents and screw information included.

Dimensions: 4" W x 7" D x 1¼" H.

EDP #11400

For stub screw machine letter drills A to Z.

Dimensions: 4" W x 7" D x 1¼" H.



EDP #11450

EDP #11450

Index for stub screw machine length fractional drills, 1/16" to 1/2" by 64ths.

Decimal equivalents and U.S.S. tap information included.

Dimensions: 4" W x 7" D x 1¼" H.

EDP #11500

For stub screw machine length drills wire gauge #1 to #60 inclusive, decimal equivalents and screw tap information.

Dimensions: 3¼" W x 4½" D x 1" H.

EDP #11550

Holds 115 stub screw machine length drills in one case. See the Combination Index section for additional details. For stub drills 1/16" to 1/2" by 64ths, 1 to 60 wire gauge and A to Z letter size.

Dimensions: 13½" W x 4⅝" D x 2¼" H.

Carbide Burr Indexes

Safely separates and holds carbide burrs of all types.

EDP #15030 Holds 8 pieces 1/4" shank.

EDP #15035 Holds 10 pieces 1/4" shank.

EDP #15040 Holds 8 pieces 1/8" shank.

Dimensions: 3¼" W x 4½" D x 1" H.



EDP #15035

Tap Indexes

EDP #12575

Holds coarse and fine

1/4" - 20	1/4" - 28
5/16" - 18	5/16" - 24
3/8" - 16	3/8" - 24
7/16" - 14	7/16" - 20
1/2" - 13	1/2" - 20

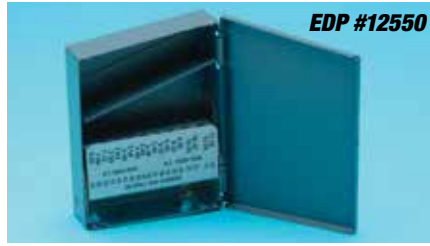

EDP #12550

EDP #12550

Holds fine and coarse

0 - 80	5 - 40	5 - 44	
1 - 72	1 - 64	6 - 32	6 - 40
2 - 56	2 - 64	8 - 32	8 - 36
3 - 48	3 - 56	10 - 24	10 - 32
4 - 40	4 - 48	12 - 24	12 - 28



EDP #12590

EDP #12590

Holds the following 10 U.S. tap sizes:

4-40NC	1/4"-20NC
6-32NC	5/16"-18NC
8-32NC	3/8"-16NC
10-24NC	1/2"-13NC
10-32NF	5/8"-11NC

Or the following 10 metric tap sizes:

16 x 2.0	5 x .8
12 x 1.75	4.5 x .75
10 x 1.5	4 x 7
8 x 1.25	3.5 x .6
6 x 1.0	3 x .5

Dimensions: All models measure 3 1/4" W x 4 1/2" D x 1" H.

Tap and Drill Indexes

EDP #12700

Conveniently combines taps with the corresponding tap drill alongside of one another.

- National Fine
- Holds sizes: 6-40 tap #33 drill, 8-36 #29, 10-32 #21, 12-28 #15, 1/4"-28 #3, 5/16"-24 #1, 3/8"-24 #Q, 7/16"-20 #25/64, 1/2"-20 #29/64.
- National Coarse
- Holds sizes: 6-32 tap #36 drill, 8-32 #29, 10-24 #25, 12-24 #16, 1/4"-20 #7, 5/16"-18 #F, 3/8"-16 #5/16, 7/16"-14 #U, 1/2"-13 #27/64.
- Clips mounted in the cover provide a handy place for securing your T-handle or adjustable tap wrench.

Dimensions: 13 1/2" W x 4 1/2" D x 2 3/4" H.



EDP #12700

EDP #12600

- National Coarse
- Holds sizes: 6-32 tap #36 drill, 8-32 #29, 10-24 #25, 10-32 #21, 1/4"-20 #7, 5/16"-18 #F, 3/8"-16 #5/16, 7/16"-14 #U, 1/2"-13 #27/64.

Dimensions: 4" W x 7" D x 1 1/4" H.

EDP #12650

- National Fine
- Holds sizes: 6-40 tap #33 drill, 8-36 #29, 10-24 #25, 10-32 #21, 1/4"-28 #3, 5/16"-24 #1, 3/8"-24 #Q, 7/16"-20 #25/64, 1/2"-20 #29/64.

Dimensions: 4" W x 7" D x 1 1/4" H.

EDP #12675

- I.S.O. 529 1975
- Holds Sizes: 2.5 x 0.45 tap 2.05 drill, 3.0 x 0.50 2.50, 3.5 x 0.60 2.90, 4.0 x 0.70 3.30, 5.0 x 0.80 4.20, 6.0 x 1.00 5.00, 8.00 x 1.25 6.70, 10.0 x 1.50 8.50, 12.0 x 1.75 10.20

Dimensions: 4" W x 7" D x 1 1/4" H.

Silver Deming

EDP #11980

Conveniently holds 8 most commonly used Silver Deming drills 9/16" to 1" by 64ths. Can be mounted to drill press or work bench. Textured black with sizes in white for easy reading.

Dimensions: 5-5/8" W x 2-5/8" D x 1-1/2" H **Weight:** 1 lb.

EDP #11985

For Silver Deming drills from 1/2" to 1" by 1/16ths held by shank.

Dimensions: 3" W x 5" D x 2" H **Weight:** 3 lbs.



EDP #11980

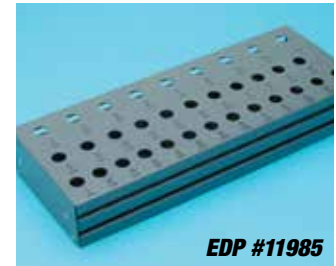

EDP #11985

Carbide Burr Stand

EDP #11875

Holds 24 each, 1/4" shank burrs. Holds up to 24, 1/4" shank burrs. Mounts on wall or drill press for easy accessibility. Made from a single piece of steel.

Dimensions: 5-5/8" W x 2-5/8" D x 1-1/2" H.

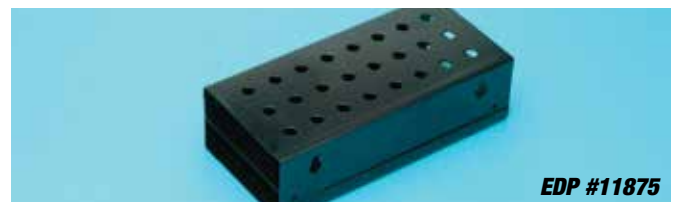

EDP #11875

Drill Stands, Jobber or Stub Screw

EDP #11850

Letter sizes A to Z inclusive

Dimensions: 5⁵/₈" W x 2⁵/₈" D x 1¹/₂" H, 3 lbs.

EDP #11900

Fractional drills 1/16" to 1/2" by 64ths inclusive.

Dimensions: 5⁵/₈" W x 2⁵/₈" D x 1¹/₂" H, 3 lbs.

EDP #11975

For jobbers and stub or screw machine length from 1/2" to 1" by 64ths "held by flute".

Dimensions: 13" W x 5" D x 2" H, 3 lbs.



EDP #11900

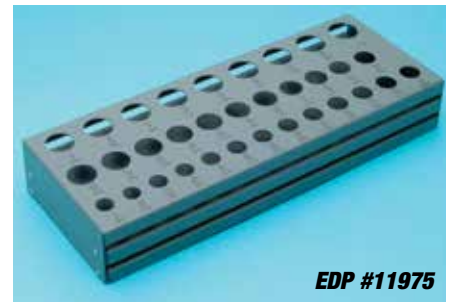

EDP #11975

Drill Gauges

EDP #12250

For measuring 1/16" to 1/2" by 64ths drill bits.

Dimensions: 6" W x 3" D.

EDP #12260

For measuring #1 to 60 wire gauge drill bits.

Dimensions: 5¹/₄" W x 2" D.

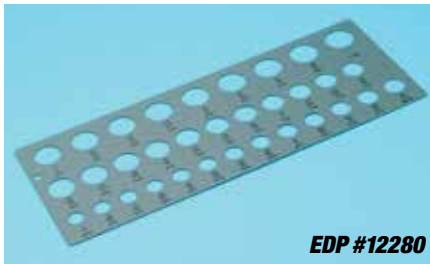

EDP #12280

EDP #12280

For measuring drills 1/2" to 1" by 64ths.

Dimensions: 13" W x 5" D.

Aerosol Can & Spray Bottle Racks



EDP #14757 Can Rack

The Can Rack easily mounts just about anywhere. Oils, aerosols, cleaners and "whatever" conveniently within your reach.



EDP #14760

Holds larger (24 oz.) spray bottle and cans with a 3.5" diameter hole. Reduces refill trips by accommodating larger bottles of sprays, liquids and lubricants.



EDP #14758



EDP #90332

EDP#	Description
90332	Double hole stainless steel spray bottle holder
90333	Single hole stainless steel spray bottle holder
14752	Double hole spray bottle holder in flat black
14758	Triple hole spray bottle holder in flat black
14760	Single hole spray bottle holder in flat black

WeldScoot

EDP #77400 - Red

EDP #77401 - Blue

Welding with organization on the go. The Huot WeldScoot facilitates storage and organization for all of your welding accessories in a portable design. This handy product allows you to bring everything you need to weld, regardless of where it is in your shop. Maximize your welding efficiency by having everything together in one portable place.

- Surface area for welder is 17.75" x 27"
- Hose winder handle keeps hose neat and secure
- Center shelf with columns and dividers for storing tips, o-rings nozzles, clamps and more
- Locking casters for stability
- Multiple trays included for securely mounting several different tank sizes.
- No flimsy loose chains here!
- Built in cups hold welding rods in upright and ready-to-use position
- Open area in center shelf for regulators, clamps, strikers and more
- Large area for welding hood, goggles and accessories

Dimensions: 35" H x 37" W x 18" D.

Weight: 77 lbs.



Scan for
YouTube video



EDP #77400

Welder, tank and accessories not included

UtilityScoot

EDP #16800

Simple, rigid, steel utility transporter. The Huot UtilityScoot is not your standard utility cart. Instead of plastic, it's built from premium cold rolled steel with the quality you would expect from Huot. Built to deliver the performance you've enjoyed from the rest of the carts in our Scoot line. For everything you need to move around your shop, the UtilityScoot delivers. See our website for more information on our complete line of storage and organization solutions.

- Tub depth is 2.25"
- Sturdy steel construction
- Scratch resistant powder paint finish
- Grab handle for easy maneuverability
- Lower shelf can be mounted in 2 positions
- Locking casters for stability
- Made in the USA!

Dimensions: 32.25" H x 27.25" W x 18.25" D.

Weight: 65 lbs.



Machine Tool Accessory Rack

EDP #14702

- Organizes components to simplify daily machine tool operation
- Mounts directly to machine tool or workbench
- Holds Bondhus 13 piece fractional and 9 piece metric hex key sets
- For use on any type or brand of machine tool for more efficient operation
- Decreases set up times of any process
- Open design, stored products are easily visible and accessible
- Compact design fits conveniently on machine tool or in machine cell
- Compatible with 5S and/or Lean 6 Sigma initiatives
- Dimensions are 17.5" L x 5.75" D x 2.75" H
- 16 gauge cold roll steel construction
- Made in USA

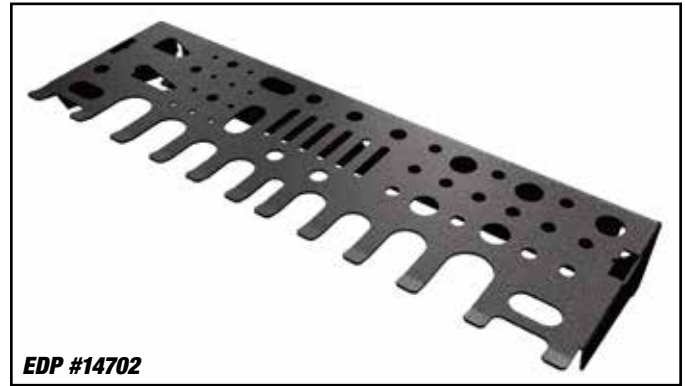

Drop-In Drawer Inserts

Have a cabinet or bench and want to store tool holders or ER collets in the drawers? These 23.5" x 23.5" drop-in inserts are designed to fit within the existing drawers of your current set up. Sturdy steel construction ensures the proper support and fit of your tools. This simple product allows for organization using the existing furnishings in your facility.

EDP#	Description 23.5" x 23.5"	Height	Capacity
22030	holds 30 taper toolholders	4"	42
22040	holds 40 taper toolholders	4"	42
22050	holds 50 taper toolholders	6"	23
22072	Divided tray	4"	N/A
22800	TG 100	4"	144
22816	ER 16	4"	361
22820	ER 20	4"	289
22825	ER 25	4"	196
22832	ER 32	4"	144

Also available for CAPTO®

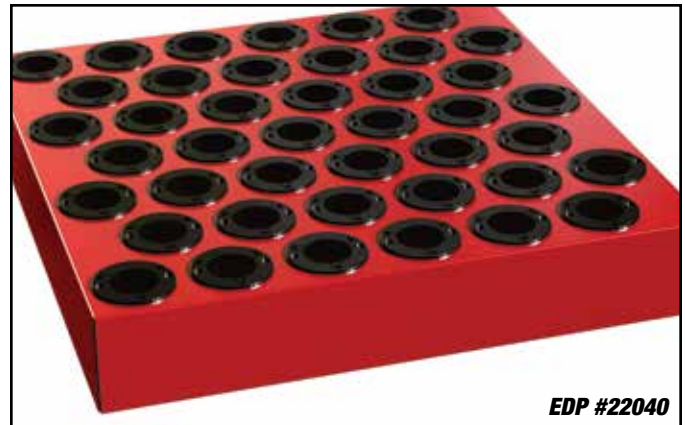
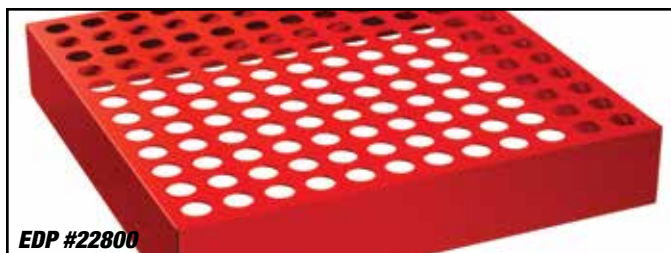

Webbing



EDP#	Description	Length
14025	For ¼" to ½" or ½" to 1" diameter tools	50'
14026	For ¼" to ½" diameter tools	100'
14027	For ½" to 1" diameter tools	100'
14028	For 1" to 1½" diameter tools	50'
14047	For 1½" to 2" diameter tools	50'
14048	For 2" to 2½" diameter tools	50'
14049	For 2½" to 3" diameter tools	50'
14050	For 3" to 4" diameter tools	50'
14051	For 4" to 5" diameter tools	50'

- Woven of tough, flexible and stretchable polyethylene.
- Great protection for delicate edges of cutting tools.
- Doubles/triples storage capacity of any drawer.
- Reusable. Slips on and off easily. Elasticity assures snug fit and non-slip grip.
- Easily cuts to any length.
- Inexpensive protection.

Molded Inserts for V-Flange, HSK and CAPTO Toolholders

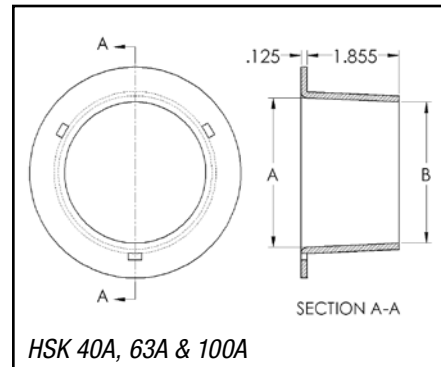

Toolholder inserts are molded using high impact plastic. The special plastic provides a highly durable material that is resistant to breakage and can withstand the weight of tooling over time without becoming brittle. With toolholder inserts 9615, 9616, 9617 and 9618, tapered tooling easily slips in to the form fitting holder, keeping the tooling safe from marring, nicks or chipping.

Item	Description	Dim. A	Dim. B
9612	30 Taper	1.298"	N/A
9613	HSK 40A	1.19"	N/A
9615	HSK 63A	1.946"	1.818"
9616	HSK 100A	3.007"	2.824"
9617	40 Taper	1.836"	1.252"
9618	50 Taper	2.835"	2.252"
2266	R8	1.125"	N/A
9624	CAPTO C4	N/A	N/A
9625	CAPTO C5	N/A	N/A
9626	CAPTO C6	N/A	N/A

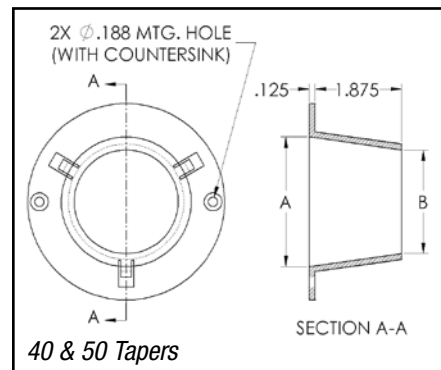

Please note that most inserts are not interchangeable. For example, if you have a 50 taper cart and you want to convert it to 40, simply ordering new inserts **will not work**. The hole in the sheet metal would be too large and the insert would drop right through. Please check with the factory before ordering.

Under-mount Drill Dispensers

- EDP# 30000** for fractional drills 1/16" to 1/2" x 64ths
- EDP# 30025** for wire gage drills #1 to #60
- EDP# 30050** for A to Z letter drills
- EDP# 30001** empty under-mount drawer, no dividers, for miscellaneous storage.

There just never seems to be an easy place to store and organize all of your drills. The Under-Mount Drill Dispenser can be mounted under a bench, attached to a desk or secured to a shelf. Ball bearing slides with built in cam locks ensure smooth operation. The keyed lock helps secure your drills where you need them.

Overall Dimensions: 26.125" W x 12.5" D x 4.5" H.

Drawer Dimensions: 23.125" W x 11" D x 3" H.

Weight: 14.5 lbs.

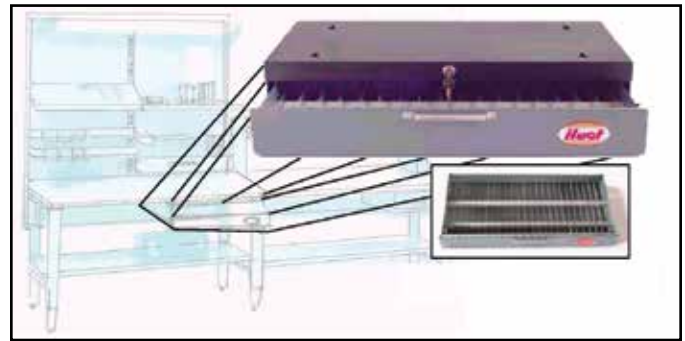

Wall Mounted Original Dispenser Cabinet

EDP #14100

Secure up to 3 original dispenser cabinets and locks using your own padlock with our wall mounted cabinet. Featuring heavy 18 gauge prime steel powder coated in our exclusive Huot battleship gray. Shipped KD and supplied with carriage bolts and nuts for easy assembly. Provide protected storage for your valuable cutting tool inventory. Wall mounted on 16" centers using your own mounting hardware.

Dimensions: 17.75" W x 9.25" D x 24.5" H.

Weight: 20 lbs.



Dispenser Drawer Divider kit

EDP #14030

- Four sections create 25 compartments in Huot Master Series standard 11" x 23-1/8" dispenser drawers and most tool boxes.
- Individual compartments are each 11" deep x 15/16" wide x 1" high.

EDP #14060

- Four sections create 17 compartments 1-1/4" wide and 11" deep.
- Vinyl compartments separate tools to prevent damage and organize inventory.
- Can be labeled for inventory control and tracking.
- Use in combination with Protective Vinyl Webbing to multiply drawer capacity.

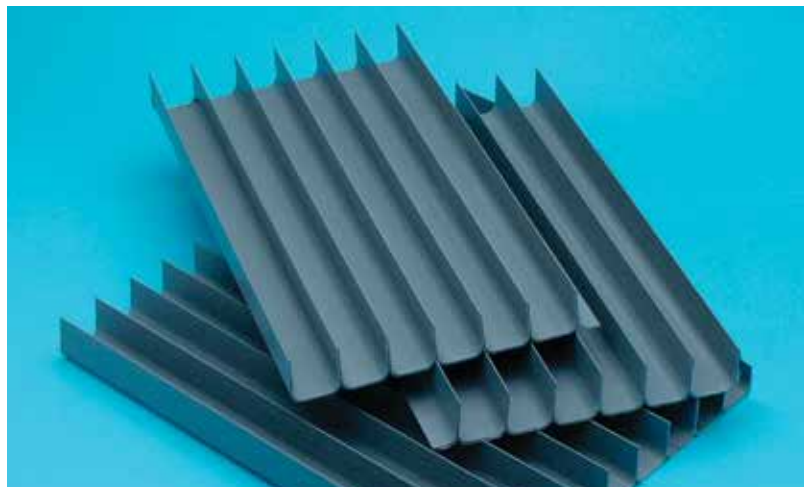

CNC Toolholder Identification

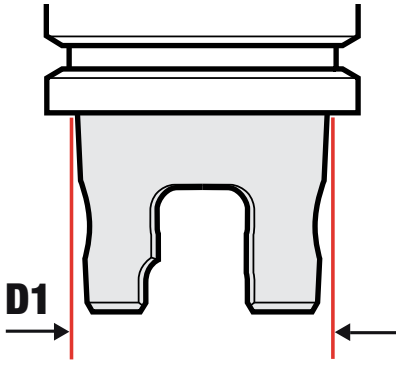

KM™ toolholders have two angled holes through the shank called “ball tracks” which act as a clamping mechanism.

KM™	
Size	D1
32	0.945 (24)
40	1.181 (30)
50	1.575 (40)
63	1.969 (50)
80	2.52 (64)

KM Registered Trademark Kennametal

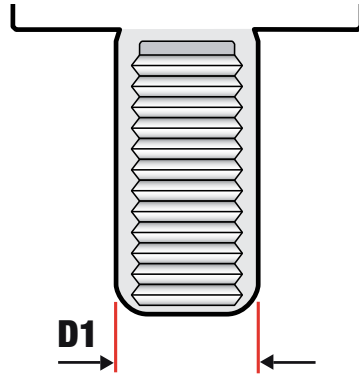

VDI toolholders come in many different shapes and sizes. One distinctive feature is the shaft is serrated on one side as shown in the illustration.

VDI Type	
Size	D1
25	0.983 (25)
30	1.181 (30)
40	1.575 (40)
50	1.969 (50)
60	2.362 (60)

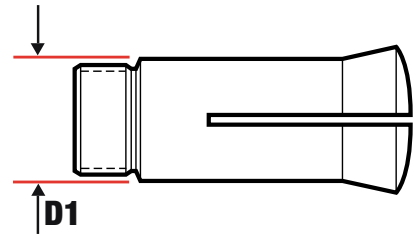

C series/3J/R8 collets have a narrow cylindrical body and a short tapered head.

C Series/3J/R8 Collets		
Size	D1	Length
5C	1.250	3.281
16C	1.889	4.312
20C	2.378	6.250
25C	2.930	6.480
3J	2.000	3.750
R8	.950	4.000

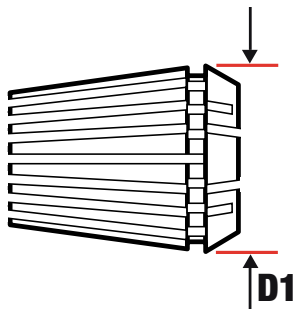

ER/RD/DR collets have a single shallow angled taper.

ER/RD/DR Collets		
Size	D1	Length
8	0.335	0.531
11	0.435	0.709
12	0.472	0.768
16	0.669	1.063
20	0.827	1.22
25	1.024	1.378
32	1.299	1.575
40	1.614	1.811
50	2.047	2.362

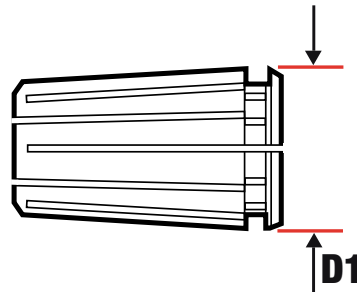

TG collets, short for tremendous grip, have a single shallow-angled taper similar to ER/RD/DR collets, but the difference between the types can be discerned by comparing dimensions.

TG Collets		
Size	D1	Length
TG50	0.76	1.438
TG75	1.062	1.844
TG100	1.379	2.375
TG150	2.001	3
TG200	2.671	3.25

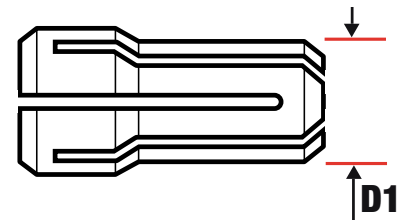

DA is short for double angle which refers to the two short angles which hold the tool in place.

DA Collets		
Size	D1	Length
DA100	0.769	1.44
DA180	1.035	1.62
DA200	0.539	1.18
DA300	0.375	1.08
DA400	1.455	2
DA500	2.255	2

Information and dimensions provided were compiled from multiple sources including but not limited to the following: "HSK Overview." Guhring The Tool Company. Guhring, Inc., n.d. Web. 31 May 2012. <<http://www.guhring.com/PS/Toolholders/Overview.htm>>. • Kennametal. Kennametal Inc., n.d. Web. 31 May 2012. <http://www.kennametal.com/en-US/home.jhtml?_requestid=904656>. • "Spindle Tooling for Manual and CNC Lathes." Hardinge. Hardinge Inc., 03 May 2010. Web. 31 May 2012. <http://www.hardinge.com/usr/pdf/collet/2348F_LR.pdf>. • Stovner, Steve. "Machine Tool Shanks (Tapers)." Tools-n-Gizmos, n.d.. Web. 31 May 2012.

CNC Toolholder Identification

When ordering Huot products it is important to determine what type and size toolholder you possess. Compare your toolholder to those illustrated, measure the D1 dimension and compare that to the dimension charts. The information and dimensions displayed are for part identification purposes only. Dimensions shown in (parentheses) are in millimeters, all others are in inches.

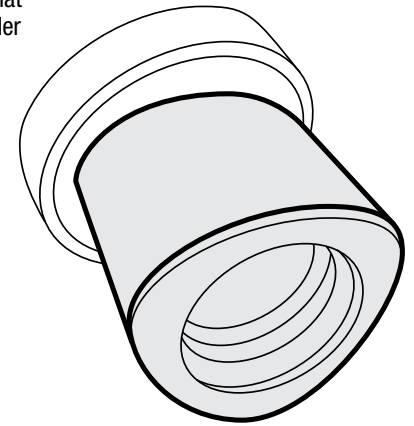
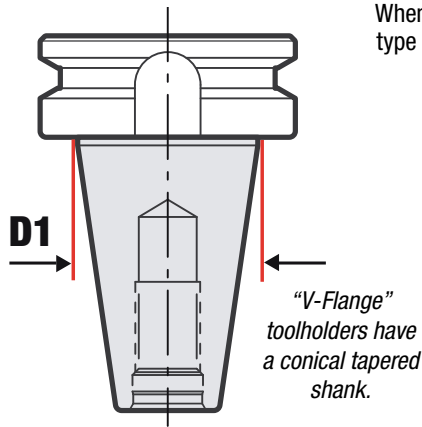

CAPTO™ including C4, C5, C6, and C8 are distinctively known for their tapered polygon shape as shown.

CAPTO Registered Trademark Sandvik Corp.

V-Flange Style				
Size	BT	CV (CAT)	DV	NMTB
25	N/A	N/A	N/A	N/A
30	1.25	1.25	1.25	1.25
32	N/A	N/A	N/A	N/A
35	1.5	N/A	N/A	N/A
40	1.75	1.75	1.75	1.75
45	2.25	2.25	2.25	N/A
50	2.75	2.75	2.75	2.75
60	N/A	4.25	N/A	N/A

CAPTO	
Size	D1
C3	(22)
C4	(28)
C5	(35)
C6	(44)
C8	(55)

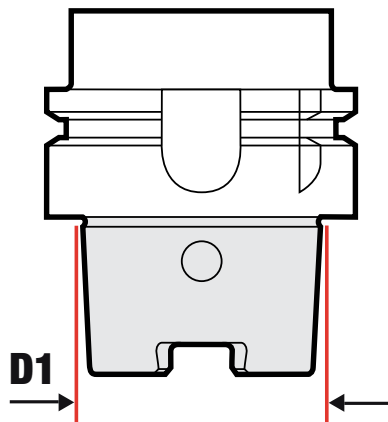
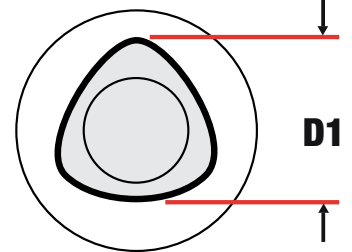

HSK's have a short hollow taper and we have identified 6 different styles.

HSK Style						
Size	HSK A	HSK B	HSK C	HSK D	HSK E	HSK F
25	N/A	N/A	N/A	N/A	0.748 (19)	N/A
30	N/A	N/A	N/A	N/A	N/A	N/A
32	0.945 (24)	N/A	0.945 (24)	N/A	0.945 (24)	N/A
35	N/A	N/A	N/A	N/A	N/A	N/A
40	1.181 (30)	0.945 (24)	1.181 (30)	0.945 (24)	1.181 (30)	N/A
45	N/A	N/A	N/A	N/A	N/A	N/A
50	1.496 (38)	1.181 (30)	1.496 (38)	1.181 (30)	1.496 (38)	1.181 (30)
60	N/A	N/A	N/A	N/A	N/A	N/A
63	1.89 (48)	1.496 (38)	1.89 (48)	1.496 (38)	1.89 (48)	1.496 (38)
80	2.362 (60)	1.89 (48)	2.362 (60)	1.89 (48)	N/A	N/A
100	2.952 (75)	2.362 (60)	2.952 (75)	2.362 (60)	N/A	N/A
125	3.740 (95)	2.952 (75)	N/A	N/A	N/A	N/A
160	4.724 (120)	3.740 (95)	N/A	N/A	N/A	N/A

See website for more sizes.

Demo Vans



Huot navigates the country with demo vans equipped with their most popular products and latest innovations. Let us come right to your shop and show you firsthand solutions for storing and organizing cutting tools and machine tool accessories. Go to our web page and click on the videos tab, then click on Huot Demo Van and enjoy the 90 second humorous and informational video. Afterwards email your address to van@huot.com and we'll let you know when we'll be in your area.



Find us on 

Huot Manufacturing

Industrial Code: 697764
 DUNS 081330734
 UPC #33603
 Tax ID #41-0653132
 SIC #3469
 ©2019 Huot Mfg.
 Form 21819
 Huot Manufacturing reserves the right to make changes and or improvements in design and dimensions without notice.

Distributed By:



**COMPLETE
 METALWORKING
 SOLUTIONS**

(800) 991-4225

www.ahbinc.com

ISO Certified

customerservice@ahbinc.com