



Vibratory Finishing Equipment

Since 1965, the founders of CLM VIBETECH, Inc. have produced, serviced, repaired and restored Vibratory Equipment. Drawing on the experience from working on almost every brand of vibratory machines, CLM VIBE TECH Inc. has designed a full line of vibratory equipment using the best features available in today's industry. As a customer said after seeing all the brands in the plant for repair, "Looks like you build the best and fix the rest". That statement is very true. From the inside out our machines are built with experience.



Model VTG-2810F

Model VT-8844
with special controls

Unbeatable Features...

- Industry's best designed and proven oil lubricated drive system incorporates double-row spherical bearings, large heavy-duty shaft and a thick-walled cartridge. (Grease lubrication system on small capacity models.)
- All heavy-duty welded construction.
- Minimum 1" thick premium polyurethane lining (three grades available including hot pour).
- Exterior mounted components provide easy access for maintenance and service.
- Extra large springs for durability.
- Most items needed for maintenance are available locally or on our shelf. We have the fewest custom made parts in the industry.
- All finishers are built strong enough to handle steel ball burnishing.
- Control panels are built to our customer's requirements, from simple push button starters to fully automated PLC controls with digital displays.
- On models with separation, there is a helical rise to aid unloading.
- Standard models, from 1.5 cu. ft. to 100 cu. ft., are custom designed to meet your application requirements.

Designed better to last longer..

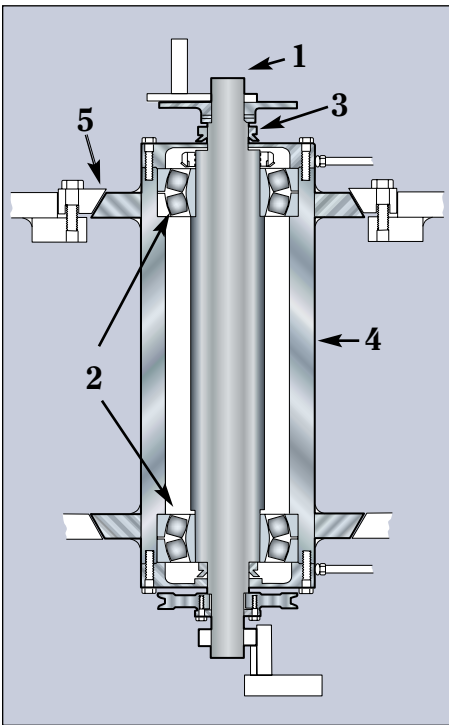

The heart of our oil lubricated vibratory finisher is the drive cartridge...

1. Heavy-duty, over-sized, precision machined drive shaft.
2. Highest quality double-row spherical bearings are fitted to drive shaft, with clearance to allow for heat expansion, unlike pressed bearings that can build-up heat and reduce bearing life.
3. Lightweight non-abrasive seals will never damage shaft.
4. For service, our extra-heavy walled cartridge is the most easily accessible and removable cartridge in the industry.
5. Tapered drive clips are pulled down with grade 9 bolts, superior to relying on bolt shear strength.

The conical structure and the center tube are designed to optimize the transfer of energy from the drive cartridge to the process channel by distributing it correctly and without unnecessary stress to the structure.

Finisher Options:

- Pneumatic Gates • PLC Automation
- Pneumatic Unload Doors • Rinse Bars
- Media Classifying • Extended Screen Decks
- Regenerative Blowers • Step-down Screens
- Gate Clearing • Material Handling
- Forward/Reversing Capabilities • Carousels
- Variable Speed • Noise Covers • Air Knife
- Settling Tanks • Shaker Screeners

Accessories for all makes:

- Drains • Gates • Compound System
- Screens • Noise and Dust Covers

Services:

- **Process Evaluation:** send us your sample parts for a free process evaluation.
- **System Design:** we can design and build custom systems from simple batch processes to fully automated systems.
- **Vibratory Equipment Repair:** we service all makes and models of vibratory equipment from basic repair to complete restoration.
- **Relining:** on all makes and models, 3 grades of urethane available from cold to hot pour.

For Service Call... 1-800-741-0670

Specification and Dimensions

	Capacity (cu. ft.)	Capacity (cu. ft.) F Models*	Motor hp (A)	No. of Drains	Lubrication System (C)	Discharge Height (D)	Channel Width (E)	Overall Diameter (F)	Overall Height (G)	Foot Print
VTG-2810 / F	1.5	1.6	2	1	Grease	33"	7.5"	28"	36"	3' x 3'
VTG-3816 / F	3.8	4	3	2	Grease	31"	9.5"	38"	36"	4' x 4'
VTG-5024 / F**	7	7.5	5	2	Grease	34"	11"	50"	42"	5' x 5'
VT-5024 / F	7	7.5	5	2	Auto Oil	34"	11"	50"	42"	5' x 5'
VTG-5524 / F**	9.5	10	7.5	2	Grease	35"	13.5"	55"	43"	5' x 5'
VT-5524 / F	9.5	10	7.5	2	Auto Oil	35"	13.5"	55"	43"	5' x 5'
VT-6026 / F	13	14	7.5	2	Auto Oil	37"	15"	60"	44"	6' x 6'
VT-6830 / F	19	20	15	2	Auto Oil	44"	17"	68"	53"	6.5' x 6.5'
VT-7230 / F	24	26	15	2	Auto Oil	44"	19"	72"	53"	7' x 7'
VT-8844 / F**	36	38	20	3	Auto Oil	56"	20"	88"	64"	8' x 8'
VT-9648 / F**	50	52	20	3	Auto Oil	56"	22"	96"	64"	9' x 9'
VT-12060 / F**	92	100	30	3	Auto Oil	65"	28"	120"	75"	11' x 11'

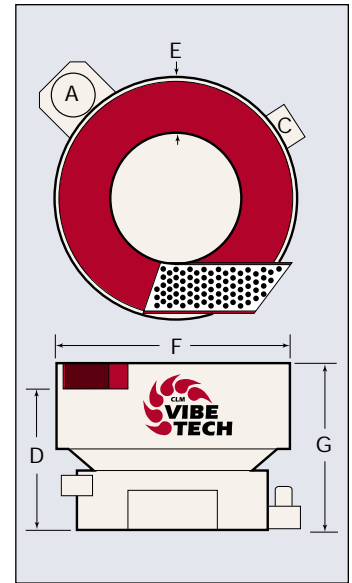

*No discharge on models ending in (F). **Not designed for steel ball burnishing. Ask about our long radius series. Due to on going design improvements, design and specifications are subject to change without notice.

In addition to our line of Finishers we have a full line of; **Vibratory Dryers, Vibratory Combos; Finisher/Dryer, Long Radius Finishers;** for excellent steel ball burnishing and longer cycle times, can be set up for continuous operations, **Helix Finishers;** for continuous operations, **Tub Finishers;** for batch processes