

AMADA MACHINE TOOLS AMERICA, INC.



AHB

TOOLING & MACHINERY

COMPLETE METALWORKING SOLUTIONS

(800) 991-4225

www.ahbinc.com

ISO Certified

customerservice@ahbinc.com

THE VISION OF PRECISION

Lineup of Grinders

 **AMADA**[®]

Amada Machine Tools America



With more than 70 years of industry experience, Amada Machine Tools America is committed to helping our customers deliver dependable service and top-quality work with exceptional grinding solutions.

Whether you need profile, forming, surface, or rotary grinding, we have the right solution for your specific needs.

Market-Leading Quality—We believe quality work begins with quality tools designed and built from the ground up to deliver outstanding performance, time after time.

Customer-Driven Innovation—Every feature, function and configuration we offer has been developed to address the needs of our customers.

Proven Accuracy—We help you take your work to the next level and exceed your customers' expectations.

Reliable Productivity—We understand productivity is the heart of your business, and we can help you optimize it in multiple ways.

Contents

Amada Machine Tools America	1
Amada Grinding Technology	2
OPTICAL GRINDERS	3
GLS 150GL Optical Profile Grinder	4
DV1 Digital Profile Grinder	10
CNC HIGH-SPEED GRINDERS	23
Meister G3 and Meister V3 High-Precision Forming Grinders	24
Winstar SP Ultra-High Precision Forming Grinder	30
ROTARY GRINDERS	43
SSR5 Rotary Surface Grinder	44
CNC SURFACE GRINDERS	49
Techster 52 and Techster 52S High-Capacity, Multi-Purpose High-Speed Grinders	50
Techster 64 and Techster 64S Saddle Type Precision Surface CNC Grinder	52
MID-SIZED CNC SURFACE GRINDERS	57
Techster 84, 104, and 126 Column Type Precision Surface Grinders	58
MULTI-FUNCTION GRINDING CENTERS	63
MX-150 Five-Axis Precision Grinding Center With Milling Capability	64

A History of Cutting-Edge Manufacturing

Since we began building profile grinders back in the 1940s, our goals have always been to provide our customers with increased accuracy and productivity. Throughout our history, we've maintained our time-honored tradition of hand-fitting our grinders to deliver the ultimate in quality and precision.

And, as technology has evolved, we've embraced CNC automation as a core strength, improving throughput and helping new operators become productive more quickly.

Today, we are uniquely positioned to help you expand your capabilities and grow your business.

Solutions Designed Around Customer Needs

No two manufacturing needs are exactly alike. Finding the right solution means thoroughly understanding your objectives and configuring a solution to match them precisely. Our engineers bring decades of industry experience to help you achieve your specified goals with a process that fits—and enhances—your workflow.

TECHNOLOGIES OF AMADA



GRINDING



MILLING



SAWING

Amada Grinding Technology



When the tightest tolerances and accurate repeatability matter, Amada is a world leader in optical profile grinding and high-precision surface and profile work. Suppliers to high-tech electronics and semiconductor manufacturers have trusted Amada grinders for years to deliver the flexibility, precision and productivity they need to stay ahead in a rapidly changing industry.

- Integrated measuring technology
- Award-winning innovation
- Maximum accuracy optimized through use of the most modern construction/design
- High speed for increased efficiency
- Integrated automation for higher efficiency
- Automatic swiveling grinding head during the grinding cycle
- External programming software to optimize part production
- Modular construction for versatile and economic specification

Engineered to Perform

Optimum Balance Supports High-Reciprocating Grinding—As a pioneer in high-reciprocating grinding and processing, we have achieved a superb, dynamic balance between the machine and the grindstone to deliver superior performance with the widest range of work materials.

High-Quality Grinding that Exceeds Specifications—The accuracy of our grinding and processing work goes beyond simply measuring RZ to deliver mark-less and sharp-edge mirror finishes.

Reliable, High-Rigidity Structure—The form of the machine has been developed by advanced three-dimensional design and finalized through a comprehensive series of demonstration tests to create high-dimensional rigidity.

Consistent Repeatability—Through superior design and meticulous assembly practices, Amada grinders are engineered to account for thermal displacement, ensuring maximum accuracy throughout the working process.

Advanced, Easy-to-Use CNC Software—Every Amada grinder has dedicated software to allow your operators to take full advantage of each machine's capabilities.

From Surface Grinding to Molding to Profile—Amada's exclusive WAPS platform gives you complete control of all forming processes—rough, semi-finish, and finish processing. It also prepares charts for optical profile grinding and data for profile dressing.

Original Measurement Technology on Equipment—Save time and steps while ensuring maximum accuracy with built-in measurement technology.



GRINDING TECHNOLOGY

Optical Grinders

Amada's optical grinders have set new standards in machining high-precision components for tool and die, mold shops, and the industry in general. With an uncompromising approach to manufacturing standards and extensive engineering expertise, we have helped our customers expand their capabilities and improve their productivity.



GLS 150GL Optical Profile Grinder

It took a fresh perspective—and 70 years of industry expertise—to deliver an advanced profile grinder with a light touch. Whether you're making mold slides, machine parts, punches and dies, or core pins, the GLS 150GL delivers the precision and efficiency you need to meet your customers' specifications.

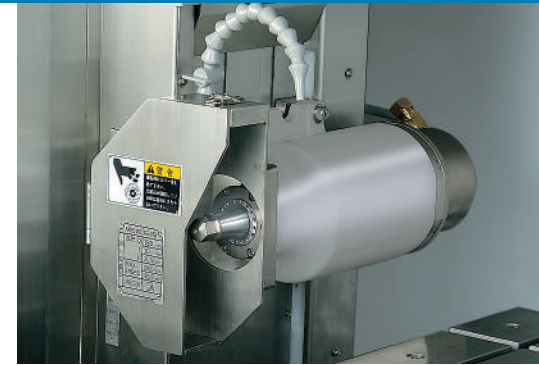

TS-6 High-Precision and High-Rigidity Spindle



Optional TC-20 High-Precision and High-Speed Spindle



Ultra-High Speed and High-Precision Wheel Heads

GLS 150GL Features

High-Accuracy/High-Definition LED Projector—A redesigned long-life LED lighting system increases brightness by approximately 15% compared to existing machines.

High-Reciprocating and High-Accuracy Wheel Heads—High-accuracy and high-resolution optical scales ensure ultra-precise feeding while an extremely rigid frame and a stable, balanced structure deliver high reciprocation rates of 400/min. Reciprocation stroke length is 6.1" (155mm). An oil-cooled inverter (allowing $\pm 0.1^\circ\text{C}$ control) is mounted as standard equipment.

Gravity Center Design Bed—The newly developed bed features an optimized allocation of jack bolts and ribbing, solving flexure at the center and supporting high static accuracy.

User-Friendly Controls—A large 10.4" screen LCD panel and easy-to-use software improve operability and support high-accuracy processing.

Shortened Setup Time—The positioning speed of each spindle axis is increased for improved efficiency, including their fast-forward speed (59"/min., 1,500 mm/min.) and table up-and-down speed (11.8"/min., 300 mm/min.). Dedicated software also enables automatic work setup.

Space-Saving Design—The GLS 150GL is approximately 25% smaller than the previous model, thanks to optimized design based on structural analysis.

High-Precision and High-Rigidity Spindle (TS-6)—The standard low-speed, high-power spindle delivers 6,000 RPM and supports a large-diameter grinding wheel.

Optional High-Precision and High-Speed Spindle (TC-20)—The TC-20 spindle provides high speed (20,000 RPM) and precision with low heat generation.

Newly Designed Ultra-High Speed and High-Precision Wheel Heads—Mirror surface finishing can be achieved in less time, and the 6.1" (155 mm) stroke accommodates a wide range of workpieces.

Tool Grinding Combining NC Swiveling Axis—The edge sensor and three-axis teaching function make grinding of blade edges with lead easy.

Coping with Wet Grinding—The newly designed wet grinding cover allows for bulk flow wet grinding of hard workpieces while reducing heat generation and wear on the grinding wheel.

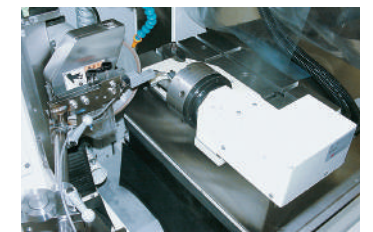

Tool Grinding Combining NC Swiveling Axis

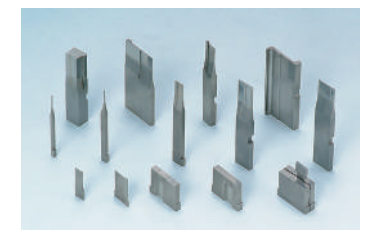

Shoulder Punch and Die



Core Pins



Ultra-High Speed and Coping with Wet Grinding



Hand Wheels



Using a High-Definition Projector



Control Panel

Optical Profile Grinding to Meet Your Highest Quality and Operation Demands

Operators can easily deliver ultra-precise machining with in-process optical inspection via the projector. This unique technology is what makes the GLS 150GL so popular. Contour accuracies down to 1µm can be achieved, and the operator can select the most suitable method of operation—manual, NC-assisted, or CNC controlled with up to three-axis interpolation. Using the teach-in playback function, even grinding wheel wear can be easily compensated.

- High-resolution projector with magnifying glass
- High-capacity and friendly FANUC CNC unit
- Fast-stroke system with up to 400 SPM
- Teach-in playback system/macro/external programming
- Built-in coolant systems for maximum accuracy (option)
- Optional C axis for three-axis interpolation



Cutting Tools

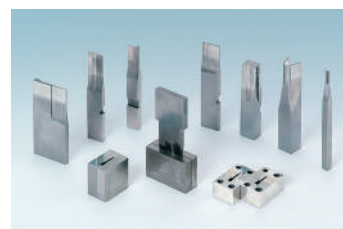

Shoulder Punch and Die

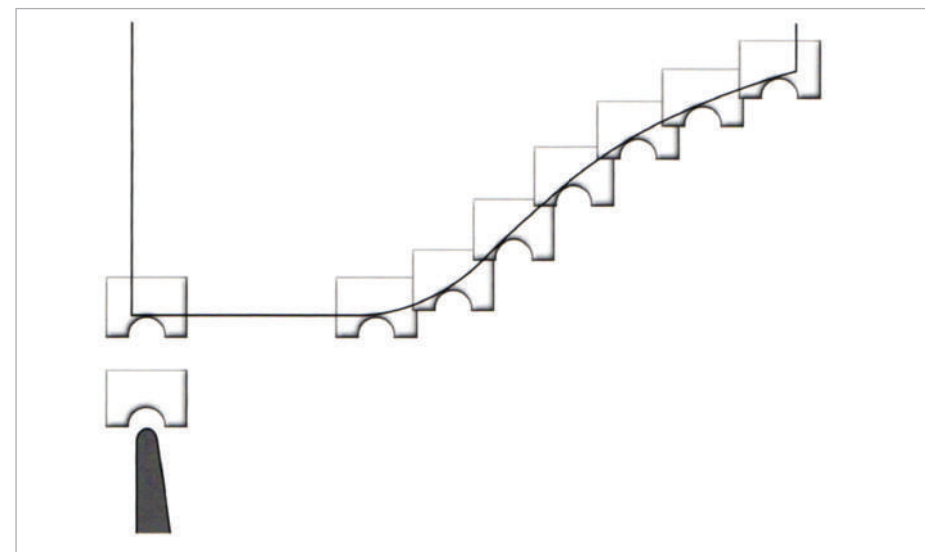

Teach-in Playback System

Examples of Mirrored Surface Polishing

Designed to deliver extreme precision, the GLS 150GL can consistently produce outstanding surface finishes to the tightest tolerances.

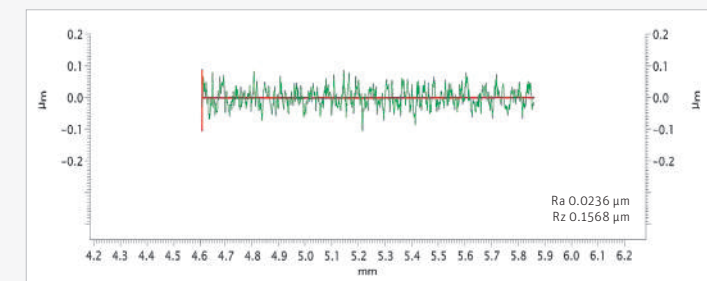

Grinding Surface Finish

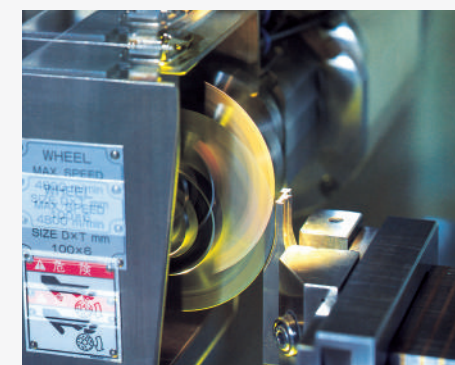

Wheel Head Design Based On Structure Analysis

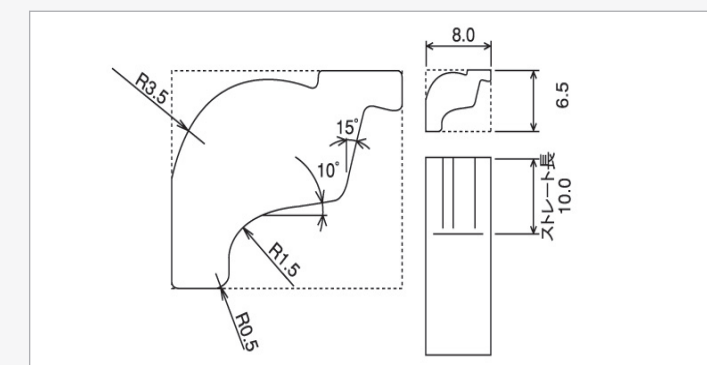

Sample Piece

Material: G5 (Cemented) Grinding Time: (Finish) 18 min
Reciprocation Stroke: 13 mm (Grinding Accuracy) ±0.001 mm



Auto Balancer

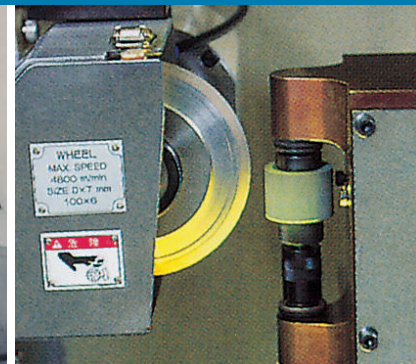

On-Board R-Form Dresser MRD-180

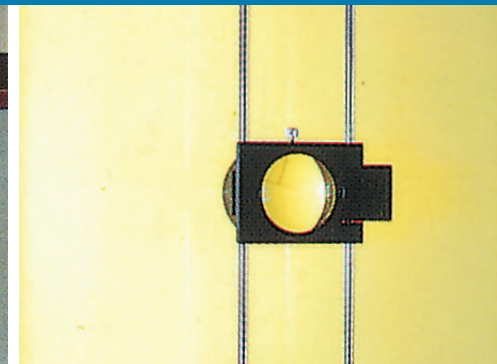

Screen Loupe

PROGRAMMING OF THE GLS 150GL

The GLS 150GL offers operators a choice of operating methods to match their desired way of control or operating skills.

- Manual operation using the hand wheels
- Using the teach-in playback system
- Using standard cycles (macro programming)
- Using external programming software

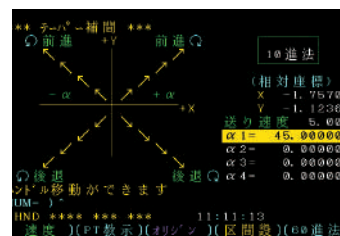

Taper Interpolation

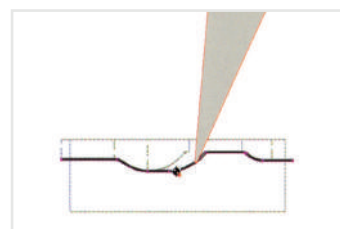

External Programming

Options for Specific Applications

Auto Balancer—This measuring instrument is used to adjust the balance of the wheel and spindle as a single unit. Perfect balancing improves the ground surface roughness.

On-Board R-Form Dresser MRD-180—This table-mount dresser is used for reforming the radius of the profiling wheel, and it's easily programmed by the operator.

Screen Loupe (P.A.T.)—The screen loupe is used to verify the work profile by partially magnifying its enlarged image and the chart for comparison. As it fits into the screen frame, both handles can be operated at the same time. Loupes are available in 2.2x and 4x magnification.

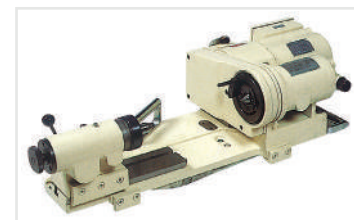

Circular Grinding Attachment—This attachment is used for grinding cylindrical parts/tools, etc.

- Swing: Ø7.87" (200 mm)
- Distance between centers: 7.87" (200 mm)
- Adaptable to dead or live centers



Automatic Work Swivel Unit (mounts to Ø1.26" [32 mm] hole)—

The automatic work swivel unit can be set to an indexable angle or to continuous feed applications. One setting can provide complete periphery processing of the work.

Machine Specifications

TABLE	Working surface (L x W)	15.7" x 9.8" (400 x 250 mm)	
	Travel	Traverse feed	11.8" (300 mm)
		Cross feed	5.9" (150 mm)
		Minimum input increment	0.000010" (0.0001 mm)
	Position detection system	Semi-closed loop	
WHEEL HEAD	Reciprocating slide stroke	0-6.1" (0-155 mm)	
	Reciprocation speed	30-400* SPM	
	Travel	Traverse feed	7.87" (200 mm)
		Cross feed	5.9" (150 mm)
		Minimum input increment	0.000010" (0.0001 mm)
		Position detection system	Full-closed loop
	Relief angle	Radial direction of wheel	-2~+20 °
		Axial direction of wheel	±15 °
		Swivel slide swiveling angle	±15 °
	PROJECTOR	Screen size (W x H)	21.25" x 16.5" (540 x 420 mm)
Magnification		20x, 50x	
WHEEL SPINDLE	Size (OD x width x bore)	Ø4.72"-7.08" x 0.12"-0.39" x Ø1.25" (Ø120-180 x 3-10 x Ø31.75 mm)	
	Wheel spindle speed	1000-6000 RPM (TS-6)	
	Motor capacity	2 HP-4 P (1.5-4 kW-P)	
FLOOR SPACE (WIDTH X DEPTH)	69.29" x 68.89" (1760 x 1750 mm)		
MACHINE WEIGHT	9900 lb (4500 kg)		
POWER CAPACITY	18 kVA		
CNC CONTROLLER	CNC unit model	FANUC	
	Display	10.4" (264 mm)	
	Manual handle	2 : X, Y (Z, V)	
	Pitch error modification	Standard	
	Number of axes	4 axis (simultaneous 2 axis)	

*Reciprocation process speed is changed by the time of reciprocation process.



DV1 Digital Profile Grinder

Take your optical profile grinding to the next level with a compact, chartless, and fully automated third-generation profile grinder. Available with five-axis control (for superior surface finishing), the DV1 can also be specified with 16 pallet stations for automatically changing out workpieces and grinding wheels, giving you the ultimate in truly “hands-off” productivity in one compact, user-friendly package.



Ultra-Precision Shoulder Punches



CCD Camera System

DV1 Features

Compact, Fully Enclosed Design—A full cover improves operational safety and environmental performance while still allowing easy access for operators.

Four-Sided Grinding for Maximum Efficiency—The CNC rotary table allows for full periphery processing with one chucking.

Automatic Measurement and Compensation Processing—The fully automated DV1 incorporates a state-of-the-art CCD camera system for automatic, on-machine measurement and compensation. That means improved precision and consistency on every job.

Process Stability—Through completely unmanned and chartless finish processing, variations in processing standards are remarkably reduced.

Verify Very Small, Fine Shapes—The automatic inspection system can qualify very small shapes of 1-degree angles or less, which cannot be easily measured with a projector.

Ideally Suited for Precision Carbide Punch Grinding—The DV1 can consistently deliver inside form tolerances of 0.0001”.

CCD Camera Automatic Instrumentation and Automatic Compensation Grinding System—Optical resolution of 10x and monitor resolution of 350x is standard equipment on the DV1. With the proven CCD camera image processing technology, full automation is achieved throughout measurement and automatic program editing.

Comparing Optical Grinding to Digital Grinding

If you use two machines for one worker, our optical profile grinder GLS 150GL requires manual form measurement and program correction, resulting in idle time for a machine. In contrast, the DV1 can perform this task automatically, resulting in shorter lead times and improved productivity.

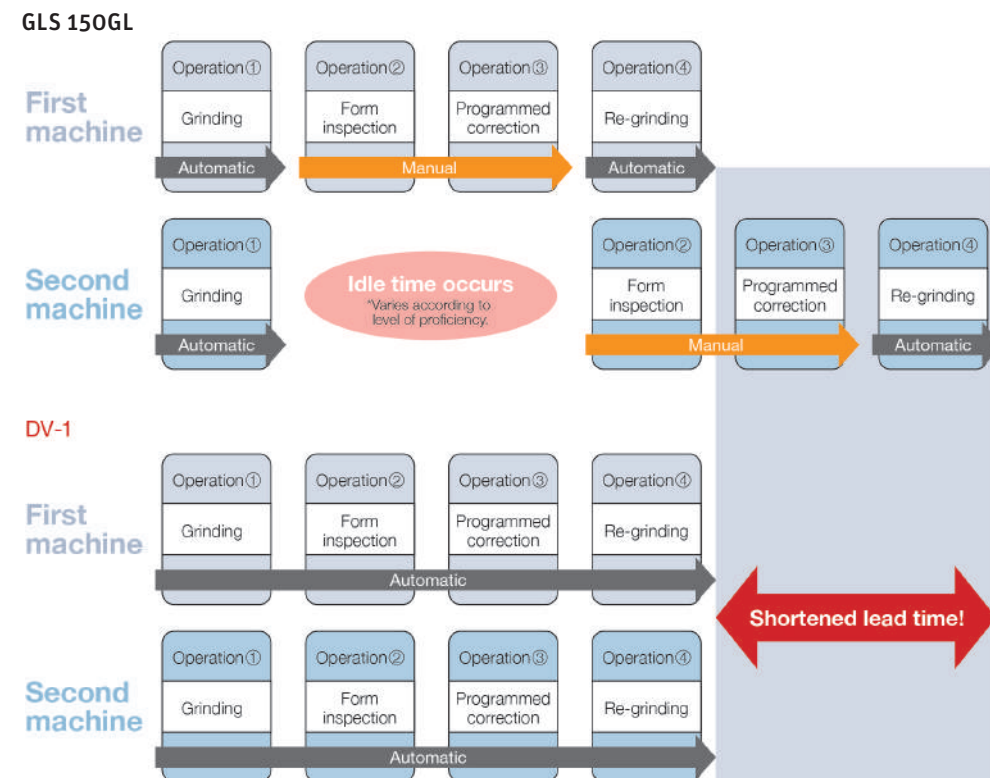

The Leader in Profile Grinding Goes Digital

Structural analysis, including 3D design, provides rigidity and compact design for the DV1. LCD displays and CCD cameras have replaced the traditional projection systems, and Mylar charts are replaced by CAD-based digital profiles. The net result is that program creation can now be based on actual digital data. Also, because the system is chartless, there's no need for a plotter. In addition, the original image teaching program function uses the CCD camera without a projector (as standard equipment), allowing for chartless instrumentation. This also allows the use of full-enclosure guards for high-performance design characteristics without any compromise in basic work efficiency.



CNC Rotary Table



Optional Full Automation Available



Operation Panel Screen

Productivity Made Easy

CNC Rotary Table Allows Four-Sided Grinding for Maximum Efficiency—With a CNC rotary table as standard equipment, the DV1 is capable of full periphery processing with one chucking. Multiple wheel operations for roughing all sides of the workpiece can be completed—completely unattended—before changing the wheel for finishing.

Easy-to-Use PC NC Interface—The PC NC operation software, accessed through a 12-inch color touch panel, significantly improves operability. The new layout of the operation panel organizes the function for both ease of use and clarity. Optimum usability makes this powerful grinder technology a pleasure to operate.

Optional Full Automation Available—With the addition of articulated robots for automated workpiece exchanges and wheel changes on the ATC spindle, the DV1 is capable of running completely unattended.

Automation that Drives Accuracy

The implementation of CCD camera systems puts the DV1 in a new class of grinding technology.

1 Automatic measurement of workpiece form with automatic re-grinding ensures repeatable precision.

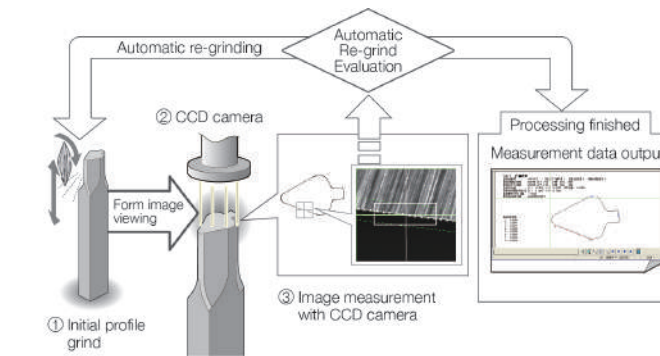

2 The DV1 can process ultra-small workpieces below an angle of 0.04" (1 mm), which is difficult to measure with a projector. In addition, the edge compensation function ensures consistency of inspection.

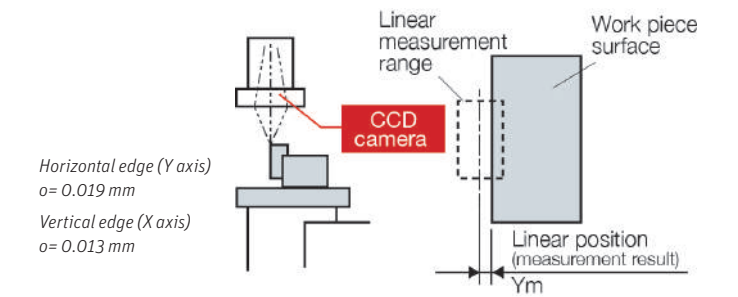

3 Automated CCD camera measurement eliminates subjective manual inspection, dramatically reducing variations in processing quality.

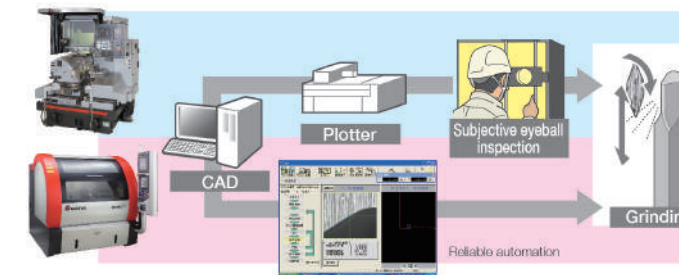

4 Measurement data can be output, providing documented part qualification.

5 Grinding wheel form measurement can be performed.

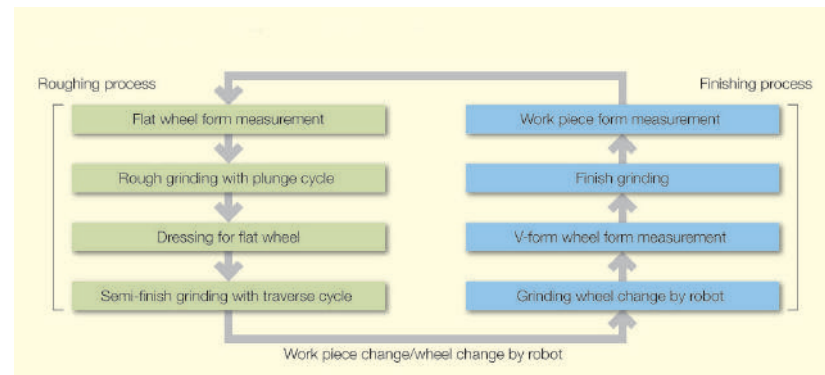

Full Automation for Roughing and Finishing Operations

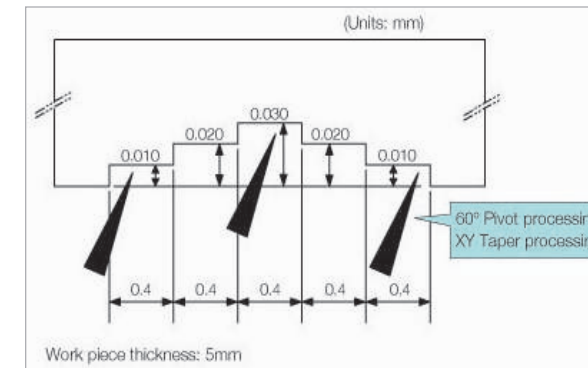

Grinding Step Profile

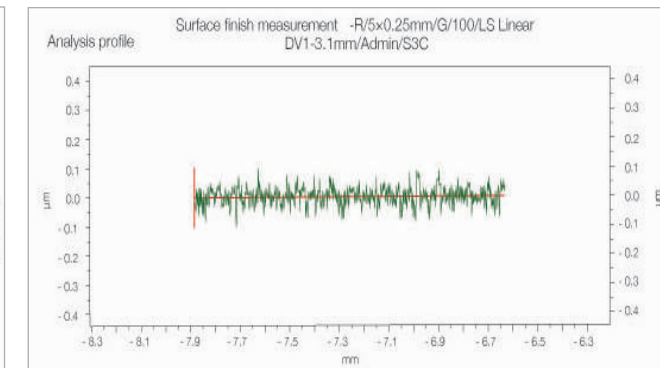

Surface Finish Measurement Data

Fully Automated Part Production with Articulated Robot and Stocker

Through automatic wheel changing, rough and finish operations are seamless and can be conducted completely unattended. The ATC spindle automatically clamps the necessary wheels to fully process workpieces, unattended. Measurement software for flat (1A1) grinding wheels automatically qualifies the wheel width/position, and an integrated rotary dresser provides peripheral, side, and corner radius dressing in flat wheels for semi-finish operations. Rough plunge cycles speed throughput.

Uncompromising Machine Design for High-Precision Form Processing

Five-Axis Controls for High-Quality Surface Finish—The DV1 employs a crank-motion elevating stand to achieve superior surface finish. The TC-20 spindle (developed by Amada for 20,000 RPM performance) supports high precision and high speed when creating small and medium shoulders. Integrated front and side clearance ensures angles that satisfy die specifications.



Five-Axis Controls For High-Quality Surface Finish

Precision in Part Processing

An ultra-hard workpiece 0.1" (2.5 mm) thick is precision-ground to within 1µm. Test piece is five steps of 10µm, as pictured, with grinding, measurement and compensated re-grind. A work surface finish of Rz0.16µm is achieved, showcasing the DV1's ability to produce "light" surface finishes.

10µm step grinding (5 steps) with automatic compensated re-grind

- Processing material: ultra-hard (G5 equivalent)
- Main spindle rotation speed: 12,000 RPM
- Reciprocation speed: 120 RPM
- Grinding wheel: TWD700R2
- Grindstone size: Ø3" x Ø0.87" (Ø75 x Ø22.23)
- Single V15°: R0.05

Straight processing (X-axis shift)

- Processing material: ultra-hard (G5 equivalent)
- Main spindle rotation speed: 12,000 RPM
- Reciprocation speed: 100 RPM
- Depth of cut: 0.0002" (0.005 mm)
- Feed speed: 0.04"/min. (1.0 mm/min.)
- Measuring machine: surface finish measuring instrument (Taylor Hobson)
- Grinding wheel: TWD700R2
- Grindstone size: Ø3" x Ø0.87" (Ø75 x Ø22.23)
- Single V15°: R0.05
- Wheel dressing device: MRD-180 dress after ~10 min. grinding time
- Dressing time: 5 min. (finish only)



Image-Based Teach and Playback

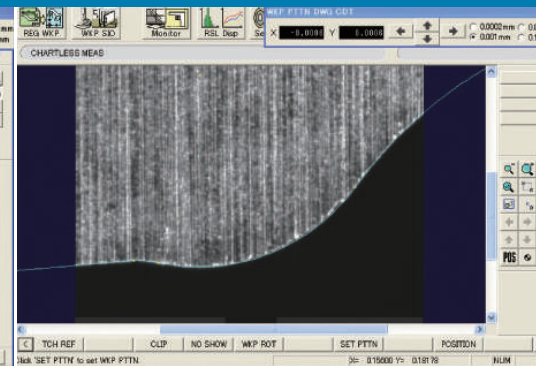

Chartless Measurement

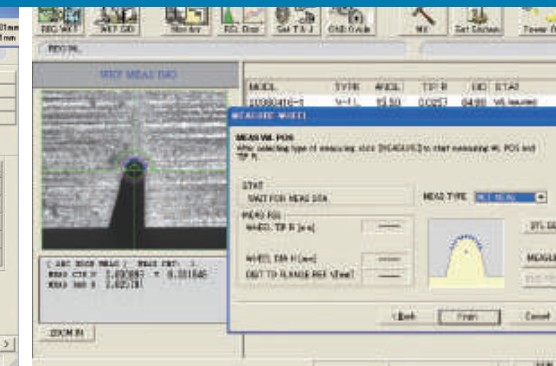

Automatic Workpiece Form Measurement/
Compensation Processing

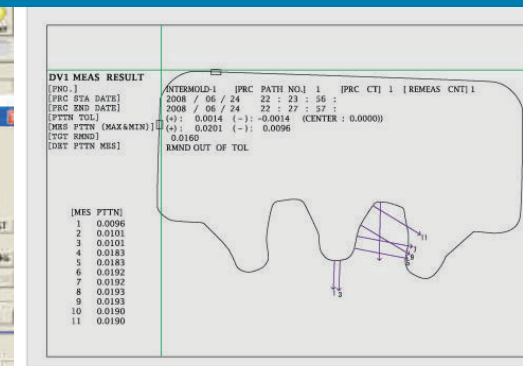

Grinding Wheel Position and Shape Measurement

Custom Software and Craftsmanship in a Digital World

The new operation panel is designed for ease of use, and the control system allows intuitive navigation through all the powerful functions.

FANUC Series 32i-B—Five-axis control specification:

- Table X, Y
- Headstock up/down (W)
- Table up/down (Z)
- Workpiece pivot (B)

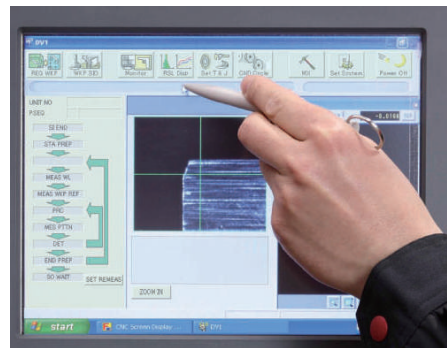

12-inch Color LCD Touch Panel (top)
USB Port (above)
Operation Panel (right)



Software

The custom software on the DV1 is designed for maximum productivity.

Image-Based Teach and Playback—

Image-based teach and playback software can create programs visually using monitor images of digital profiles, providing digital accuracy instead of projector-and-chart methods. Additionally, using digital profiles enables automatic measurement of the workpiece profile by measuring the CCD camera image of the workpiece against the actual digital image.

Image teaching provides an actual, wheel-based profile by capturing digital images of the wheel profile. Then the wheel image is used to “teach” the wheel path against the digital workpiece profile. Actual teaching is done by manipulating the handle.

Chartless Measurement—

CAD data (DXF) is loaded and, based on the processing data, the position of the workpiece image is set. When the manual handle is turned, the workpiece image moves. Similarly, by moving the cursor on the NC screen, the workpiece image moves, and the software can determine the difference.

Automatic Workpiece Form Measurement/Compensation Processing—

After the grind operation is finished, the standard position is confirmed and measurements are made to determine the deviation from the standard. This is done automatically—no operator intervention or programming is required.

At the time of measurement, multiple points are simultaneously inspected and large deviations from the standard are disregarded. The measured image area is as small as 0.019" (0.5 mm). In order to measure areas less than 1µm, the number of pixels and dots is set.

Grinding Wheel Position and Shape Measurement—

The on-board dresser unit re-trues the leading edge radius of the grinding wheel. The shape of the grinding wheel is plunged into the dummy workpiece fixtured to the table. Through the dummy, the profile of the grindstone radius is measured at multiple points, and determined by CCM calculations. Taking measurements at multiple points minimizes errors. This procedure automatically qualifies both the wheel radius and wheel position, greatly facilitating the setup process.

Machine Specifications

PROJECTOR	Screen size	12" LCD (CCD view range 0.5 x 0.4 mm)		
	Magnification	Optical magnification x10/monitor magnification x350		
	Lighting	Tapering lighting 150 W		
	Working surface	4.5" (Ø115 mm) (round table)		
	Distance from the table top to focus point	7.8" (200 mm)		
	Maximum loading weight	44 lb. (20 kg) (workpiece + fixture + chuck)		
	TABLE	Travel	Traverse feed (X axis)	11.8" (300 mm)
Cross feed (Y axis)			9.8" (250 mm)	
Vertical feed (Z axis)			3.1" (80 mm)	
Linear axis		Feedrate	Rapid traverse (G00)	XY: 78"/min, Z: 19.6"/min (XY: 2000 mm/min, Z: 500 mm/min)
			Linear interpolation (G01)	XY: 0.0004-39"/min (XY: 0.1-1000 mm/min, Z: 500 mm/min)
		Jog feed	XY: 78"/min (2000 mm/min), Z: 19.6"/min (500 mm/min)	
		Minimum input increment	0.000010" (0.0001 mm)	
Position detection/ scale resolution		X and Y axes	Full-closed/0.05 µm	
		Z axis	Semi-closed	
Rotary axis B		Travel	360°	
		Feedrate	Rapid traverse (G00)	1000°/min
			Linear interpolation (G01)	0.1-1000°/min
		Jog feed	1000°/min	
		Minimum input increment	(0.0001°)	
	Position detection/scale resolution	Full-closed/±5°		
WHEEL SPINDLE	Wheel size (outer diameter x width x hole diameter)	Ø2.5"-3.9" x 0.15"-0.25" x 0.875" (Ø65-100 x 4-6 x Ø22.23 mm)		
	Spindle nose	Ø1.0" (Ø25.4 mm) 1/4 taper		
	Spindle speed	2000-20000 min ⁻¹ (TC-20)		
WHEEL HEAD	Reciprocating axis	Reciprocating slide stroke (W axis)	0 - 3.14" (0-80* ¹ mm)	
		Drive system	Crank	
		Reciprocation speed	1.18"-15.7" (30-400 mm) (in case of 10st)* ²	
	Relief angle	Travel	Radial relief angle (V axis)	-1-2° (manual operation)
Axial relief angle (A axis)			±3° (manual operation)	

MOTOR	Wheel spindle	2 HP~4P (1.5~4 kW-P) (TC-20)
	X/Y axes	1 HP (0.75 kW)
	Z axis	.67 HP (0.5 kW)
	B axis	.06 HP (0.05 kW)
	Reciprocating axis (W axis)	2.5 HP (1.8 kW)
	Automatic lubrication	4 W
POWER CAPACITY	13 kVA	
MACHINE SIZE (WIDTH X DEPTH X HEIGHT)	64" x 93" x 67" (1630 x 2370 x 1717 mm)	
MACHINE WEIGHT	8800 lb (4000 kg)	

*¹ Length that can be processed will vary depending on the setting of relief angle.
*² There is limitation depending on the reciprocation stroke.

NC Control Specifications

CONTROL UNIT MODEL		FANUC SERIES 180i-MB
NUMBER OF CONTROL AXES	5-axis control specification	Table X, Y; table vertical Z; reciprocation W; workpiece rotary B
STANDARD FUNCTIONS	12" color LCD (touch panel)	Manual reference return
	PC NC (O/S Windows XP)	Memory-type pitch error compensation
	CNC screen display function	Feedrate override 0 to 200%
	Wheel spindle infinitely variable-speed drive (inverter control)	Tape memory 40m (16kB)
	Simple S command (7-speed)	Registerable programs 63
	Reciprocation 20-speed (servo control)	Total tool offset pairs 32
	Circuit breaker (30mA)	Tool length compensation
	Auto power off	Rapid speed override
	AC100V outlet (2P-1 outlet)	Warm-up timer (daily timer)
	3 manual handles	Memory card I/O
	(5-spindle control specification: common to X axis, Y axis, Z/B axis)	
	Handle magnification ratio Off, x1, x10, x100	Table setup function
OPTIONAL FUNCTIONS	Additional memory (80, 160, 320, 640, 1280m)	Run hour and parts count display
	Additional registerable programs (125, 200, 400)	Cycle time stamp function
	Additional tool offset pairs (64, 99, 200, 400)	Automatic corner override
	Weekly timer	
	I/O interface	
LAN connection (additional Ethernet function/connector for the PC part) * ³		

*³ Device for LAN connection is added. The network connection for the PC part should be set by customer.

Software

	DV1 SOFTWARE (APPLICATION FOR PC)	CONVERSATIONAL MICROSOFTWARE, ETC.
STANDARD FUNCTIONS	Image teaching playback	Wheel data recording function
	Chartless measurement	Fixture recording function
	Processing simulation display	Simple S command (7-speed)
	Workpiece standard measurement	Warm-up setting
	Processing actual performance display	
	Wheel position measurement (wheel transcription form measurement)	
	Automatic workpiece form measurement/correction processing software	
OPTIONAL FUNCTIONS	Rough grinding cycle	Taper interpolation
	R-forming dress software	Simple circular interpolation
	Outside auto programming software ASSIST DV*4	Repeat cycle
		Run hour display function

*4 Not compatible with WAPS WIN.

Floor Layout DV1 Stand-Alone Specification

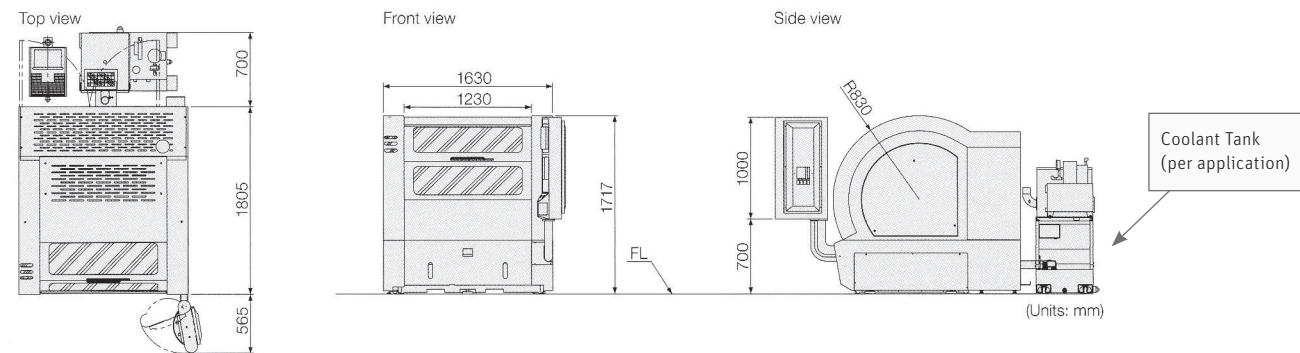

Multi-Axis Robot Stacker Specification

ROBOT	Robot	Manufacturer: FANUC	
	Number of controlled axes	6 axes	
	Maximum travel	35" (892 mm)	
	Maximum delivery weight	11 lb (5 kg)	Including robot hand
	Machine weight	63 lb (29 kg)	
STOCKER	Maximum number of stocked pallets	12 pieces	4 pallet x 3
	Maximum number of stocked wheel flanges	4 pieces	4 tools x 1
	Maximum workpiece size	4.5" x 3.5" (Ø115 mm x 90 mm) from pallet top surface	Pallet diameter 3.14" (Ø80 mm) is available
	Maximum wheel size	Ø2.9"-3.3" x 0.15"-0.23" (Ø75 mm-85 mm x 4 mm to 6 mm)	



GRINDING TECHNOLOGY

CNC Grinders

Amada's user-friendly software makes numeric control easy for operators with a wide range of experience. Coupled with the exceptional precision these machines deliver, Amada CNC grinders can help your business thrive.

Meister G3 and V3

Meister G3 and V3 HIGH-PRECISION FORMING GRINDERS



Core Pin Parts

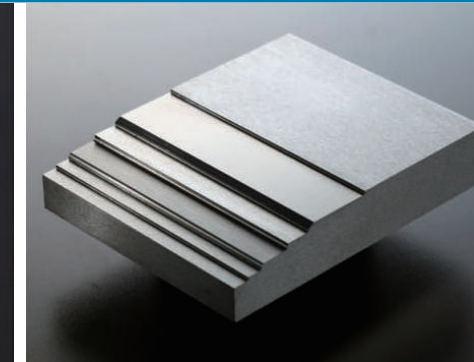

Contour Grinding

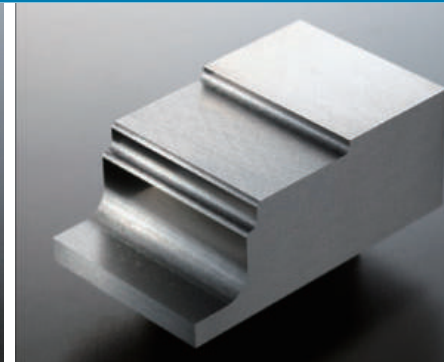

Contour Grinding



Meister G3 and Meister V3 High-Precision Forming Grinders

The Meister series of grinders offers outstanding versatility for every use—from simple to complex grinding tasks.

Steel, carbide, ceramics, and other materials can be ground in manual mode or in CNC mode. The machines come equipped with dressing and continuous path grinding technology and can be used for surface and profile grinding.

The Universally Recognized Masterpieces

The Meister G3 and Meister V3 deliver ultra-precision surface and profile grinding with a fast-stroke mechanism. Advanced standard equipment includes CNC units, high-precision dressing and continuous path grinding technology for Y and X axes, spindle and hydraulic cooling, ceramic spindle bearings, and full enclosures.

The control units of the Meister Series grinders offer optimum operability. Sophisticated macros make programming extremely convenient, even for inexperienced CNC users.

A touch probe mounted on the grinding head measures the workpiece. Residual grinding allowances are automatically calculated and the machine will repeat the grinding cycle in unattended operation until the finish dimension has been reached—quickly and safely. And, the touch probe can now determine the start position of the grinding wheel on the workpiece.

Four-Fold Increase in Productivity

By way of direct comparison, users analyzed the machining time for a pair of mold and die parts made of carbide. Thanks to the convenient programming of the Amada grinding software and the fast-stroke mechanism, time savings of 75% can be reached compared to a CNC profile grinding machine.



Automatic Measurement Equipment



Ultra-Precision Parts

Mold Tool Parts

Meister G3 and V3 Features

- Grinding area
 - Meister V3: 6" x 14" (152 mm x 355 mm)
 - Meister G3: 8" x 16" (203 mm x 406 mm)
- High-quality equipment for surface, plunge-cut, and continuous path grinding as well as dressing
- Fast-stroke system
- Spindle available with ceramic bearings and 8,000 RPM capacity (option)
- High-resolution measuring systems
- Contour dressing and contour grinding with external programming software
- Built-in touch probe technology
- Three separate hand wheels for easy setup and manual operation
- Built-in coolant system for increased thermal stability

Vertical Feed System—The column has a symmetrical structure to minimize thermal deformation and is covered with heat-insulating materials for protection against changes in temperature and other environmental factors.

The fully enclosed loop feedback system with the linear scale of 0.05µm resolution is standard for the Meister G3 (optional for others).

Wheel Spindle—The 3 HP (2.2 kW) spindle motor and inverter is standard on all models.

The spindle cooling system with oil color (±1°C) is standard on the Meister G3 (optional for others).

Table—The table features “V-V” slideways for exceptional straightness and features a servo-valve-controlled transverse drive system with teaching function.

The Meister V3 features V-flat slideways with hollow runners for high speed and high accuracy.

Bed—The position of the jack bolts and ribs on the bed are optimized to support high-speed table reciprocation.

New Model Control/Operation Panel—The space-saving control panel with original software can improve machining efficiency.

RAPID RECIPROICATION TABLE

Meister Series grinders support reciprocation speeds two to three times faster than any former model, greatly improving machining efficiency.

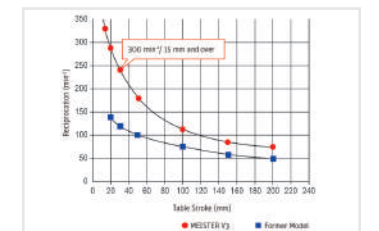

PROVISIONS TO PREVENT THERMAL DISPLACEMENT

The hydraulic unit is isolated from the main body and the hydraulic oil temperature is maintained at ±1°C by the built-in oil temperature controller.

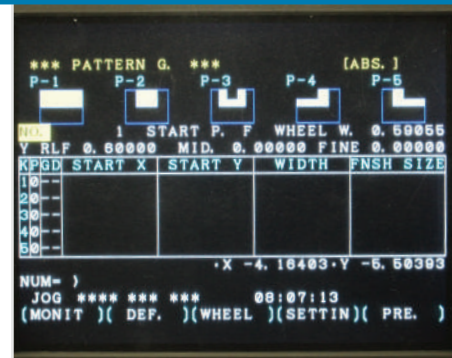

Pattern Grinding

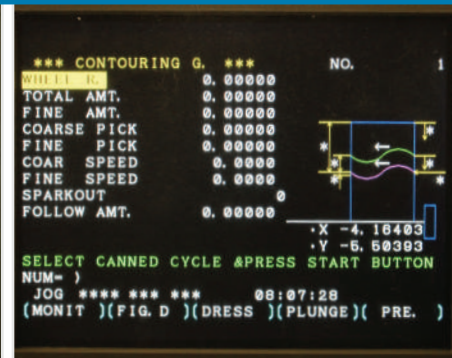

Contour Grinding

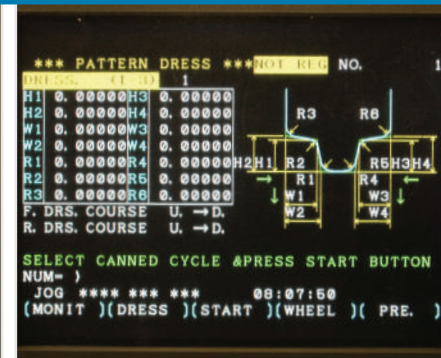

Pattern Dressing

Original Software

The software of Meister G3 and V3 grinders enables your operators to become productive without having to know complex NC programming.

Pattern Grinding—Complex shapes can be processed easily by combining five patterns. The combination of plunge and traverse options makes selecting the appropriate processing easy.

Contour Grinding—Molding grinding can be implemented by inputting the graphic data of arbitrary shapes. Rough grinding by plunge grinding can also be implemented, and the created data can be saved in the NC program area.

Pattern Dressing—By inputting the dimensions required for the basic shape on the screen, the grindstones perform the molding using a simple profile dresser, NC profile dresser, or high-speed wafer dresser. The grindstones can also perform the molding during processing and interrupt dressing.

Machine Specifications

	MEISTER G3	MEISTER V3		
CAPACITY	Table working surface (L x W)	21.6" x 7.8" (550 mm x 200 mm)	17.7" x 5.9" (450 mm x 150 mm)	
	Max. longitudinal travel	23.6" (600 mm)	19.6" (500 mm)	
	Max. cross travel	9.8" (250 mm)	7.8" (200 mm)	
	Spindle center height from table	15.7" (400 mm)	15.7" (400 mm)	
TRAVEL	Standard chuck size (L x W x H)	15.7" x 7.8" x 3.9" (400 mm x 200 mm x 100 mm)	13.7" x 5.9" x 3.9" (350 mm x 150 mm x 100)	
	Longitudinal feed	3-131 ft/min*		
SADDLE	Max. no. of reciprocation (15 mm stroke)	250 min ⁻¹ *	250 min ⁻¹ *	
	Rapid cross feed (jog)	0-1312 ft/min, 1640 ft/min, 3280 ft/min		
	Handle feed	Per rev.	0.0004", 0.004", 0.04", 0.15" (0.01 mm, 0.1 mm, 1.0 mm, 4.0 mm)	
		Per grad.	0.000004", 0.00004", 0.0004", 0.0015" (0.0001 mm, 0.001 mm, 0.01 mm, 0.04 mm)	
	Minimum input increment	0.000010" (0.0001 mm)		
	Position detection system	Glass scale/0.05µm		
WHEEL HEAD	Rapid wheel head feed (jog)	3.9"/min, 39"/min (100 mm/min, 1000 mm/min) (2 steps)		
	Handle feed	Per rev.	0.0004", 0.004", 0.04", 0.15" (0.01 mm, 0.1 mm, 1.0 mm, 4.0 mm)	
		Per grad.	0.000004", 0.00004", 0.0004", 0.0015" (0.0001 mm, 0.001 mm, 0.01 mm, 0.04 mm)	
	Minimum input increment	0.000010" (0.0001 mm)		
Position detection system	Linear scale 0.05 µm (standard)	Linear scale 0.05 µm (OP)		
WHEEL SPINDLE	Size (OD x width x bore)	Ø8" x 0.25"-1" x Ø1.25" (Ø205 mm x 6.4 mm-25 mm x Ø31.75 mm)		
	Wheel spindle speed	500 min ⁻¹ -5000 min ⁻¹		
	Motor requirement	3 HP-2 P (22-2 kW-P)		
NC CONTROL AXIS			Simultaneously 2 axis	
FLOOR SPACE (W X L X H)	105" x 80" x 74" (2670 mm x 2040 mm x 1900mm)	74" x 58" x 74" (1880 mm x 1475 mm x 1900mm)		
MACHINE NET WEIGHT	5280 lb (2400 kg)	4840 lb (2200 kg)		

* The table speed depends on work load on the table.

Winstar and Winstar SP

Winstar and Winstar SP ULTRA-HIGH PRECISION FORMING GRINDERS



Winstar and Winstar SP Ultra-High Precision Forming Grinders

The Winstar SP was specifically designed for users who push their demands for quality, dimensional accuracy, and flatness to the limits of technical feasibility.



NC Index Magnetic Chuck



High-Precision Rotary Dresser

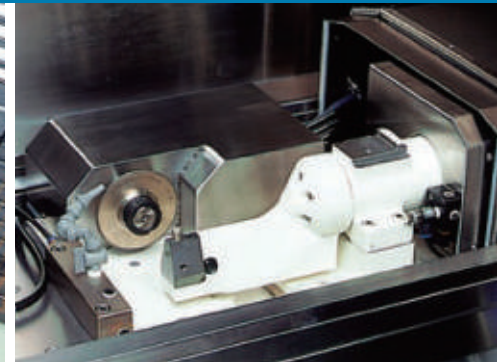

NC Profile Dresser

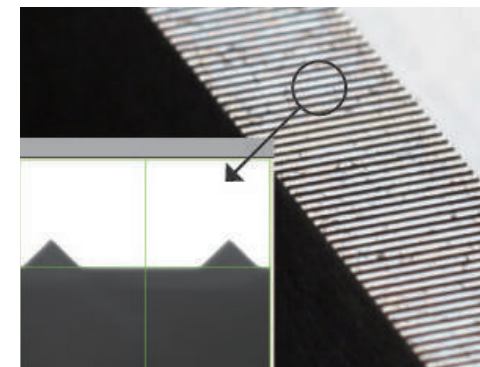

Micro Pitch Grinding (100 Slots), Height:
0.002" (0.05 mm) P 0.01" (0.3 mm)

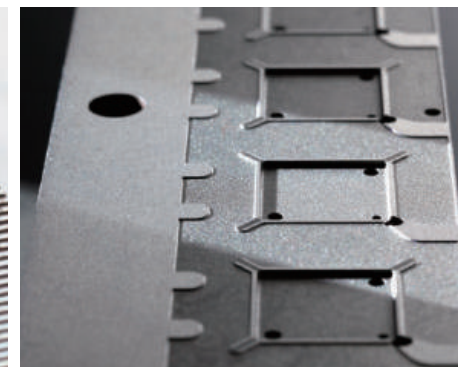

Air Vent Grinding

Solutions for Today's Grinding Needs

With a stable platform, reduced thermal displacement, and a space-saving full enclosure, the Winstar SP delivers outstanding repeatability. It also delivers short lead times and the unmatched grinding precision required in all technology-driven markets, including medical, semiconductor, and electronics.

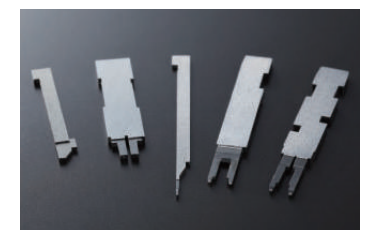

Core Pin Parts

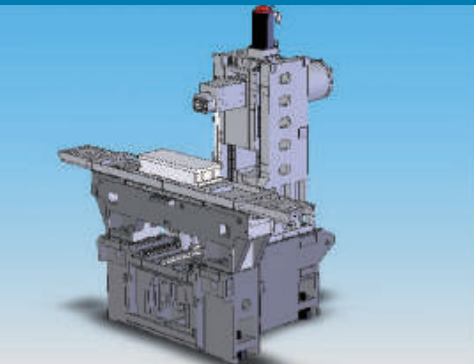

Proprietary Column Type



Ultra-Low Vibration Spindle Motor



Specifications Guarantee High Productivity



NC Swivel Rotary Dresser



Twin Dresser

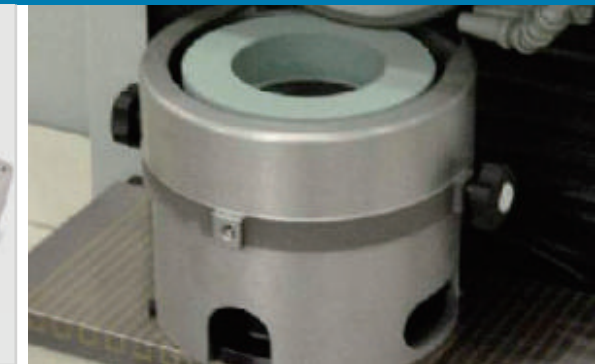

Vertical Rotary Dresser

Winstar Ultra-High Precision Forming Grinder

One of our best-selling forming grinders, the Winstar features an ultra-low vibration, oil-cooled spindle motor that delivers mirror-surface finishing for a wide range of applications.

Proprietary Column Type, Three-Plane Independent Structure—The Winstar’s foundation is a T-bed with an elongated slide and column base. High static accuracy is ensured through an independent moving column design that provides excellent operability. In addition, the V-V slideway is fully supported, eliminating overhang and maintaining superior straightness accuracy.

Table Reciprocating Specifications Guarantee High Productivity—The Winstar uses a high-speed servo valve for high-speed stroking. At a 0.59" (15 mm) stroke, it can achieve 200 SPM inverse velocity. All series models boast high stroke reversal accuracy for stop grinding and can supply accurate longitudinal processing.

Features for a Wide Range of Grinding Needs

NC Swivel Rotary Dresser—The swivel rotary dresser achieves high-precision form dressing by means of three-axis simultaneous control with “normal” position dress capability. Together, they provide a leap in wheel-forming accuracy, from taper to straight, and radius forming. High-speed diamond disk dressing also greatly reduces inaccuracies due to diamond wear.

Twin Dresser TD-100—Previously, thin wheel dressing with a conventional wheel required a high degree of skill. But, by using the TD-100, dressing efficiency has made a great leap forward. Through the use of new, thin grinding wheels, forming widths of 0.0019" (0.05 mm) can be done by operators of any skill level.

Vertical Rotary Dresser VRD-125—A motorized rotary dresser with a high-rigidity spindle delivers high-performance truing. Dressing can be performed on diamond and CBN wheels.

Automatic Measurement System (Touch Sensor)—The touch sensor automatically performs measurements after grinding to given dimensions within a canned cycle, enabling the machine to automatically re-grind surfaces when measurements are out of tolerance. Measurement resolution is 0.05µm (0.000002"), and it also supports multiple workpiece measurement. Automatic workpiece approach setting is an optional function.

High-Speed Spindle 10,000 min⁻¹—Equipped with an ultra-low vibration (V1) 2.2 kW oil-cooled high-speed motor. It provides 2.2 kW at 2500 min⁻¹ and covers a wide range from normal grinding to the high-speed range.

Both the spindle and motor use ceramic ball bearings, supporting high RPMs. While enabling wheels with smaller bores, it still provides power for high-speed grinding.

Canned Software Cycles Provide Simple Operation—Canned cycles are fixed cycles that give operators full command of the technology without the need to know complicated G-code programming.

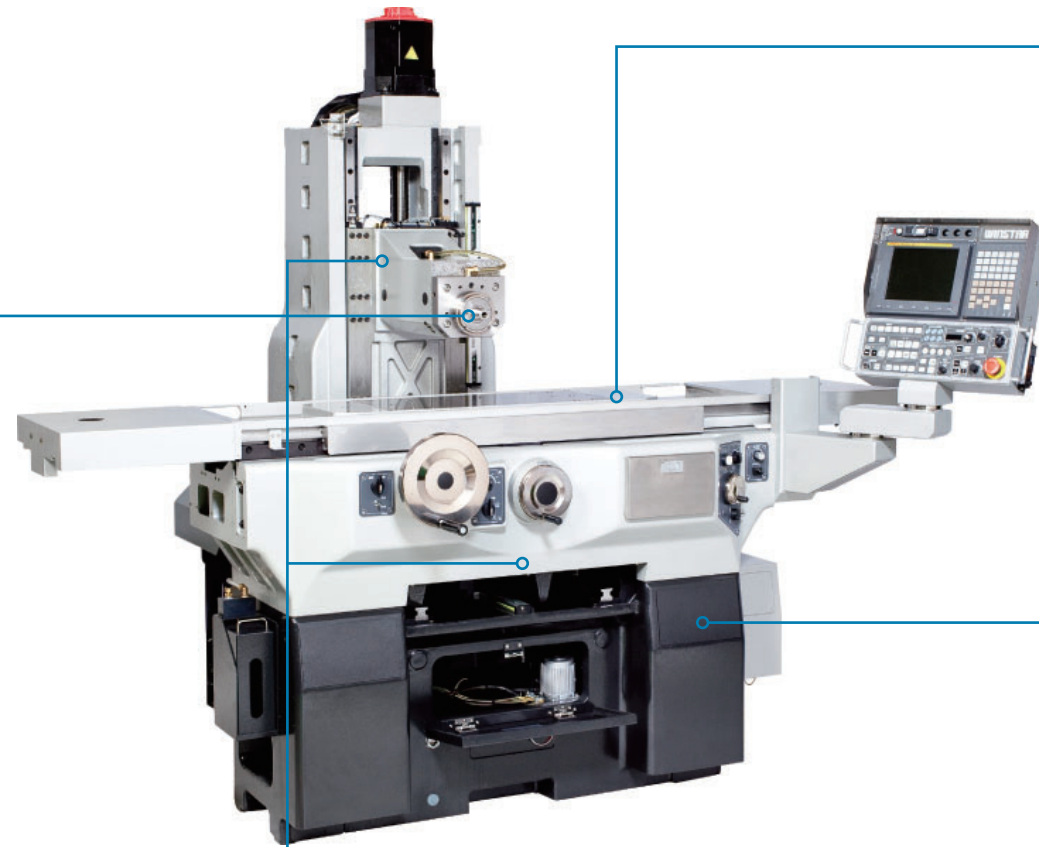

ULTRA-LOW VIBRATION SPINDLE MOTOR FOR ULTRA-MIRROR SURFACE FINISHES

The grinding spindle achieves ultra-mirror surface finishes through a class V1 ultra-low vibration, oil-cooled spindle motor. The motor is equipped with an extra oil bath cooling function as standard equipment, which provides great thermal stability.

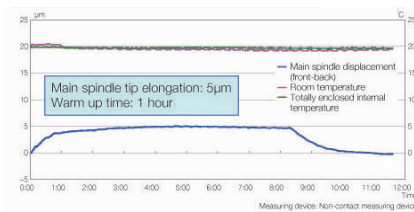

Main Spindle Thermal Displacement (Winstar Sp)

HYBRID GUIDE SURFACE WITH GLASS LINEAR SCALE

This system uses both a linear roller guide slideway (that achieves submicron accuracy) and a hybrid box way for sliding surfaces with enhanced vibration dampening for the vertical and cross axes. A 0.000002" (0.05µm) resolution scale is also included as standard equipment.

Less than 0.000004" (0.1µm) backlash capability (Winstar SP).

- X axis: 0.000026"/0.000027" (0.68 µm/0.7µm)
- Y axis: 0.000028"/0.000027" (0.71 µm/0.7µm)

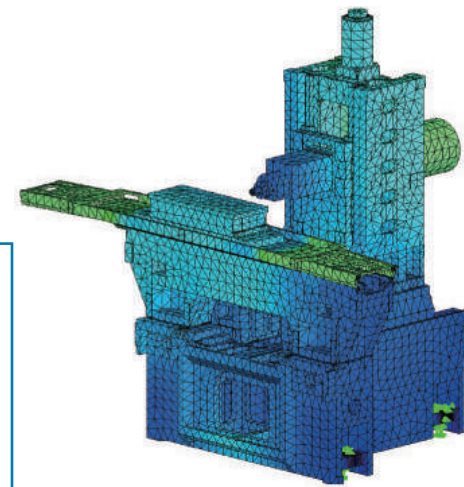
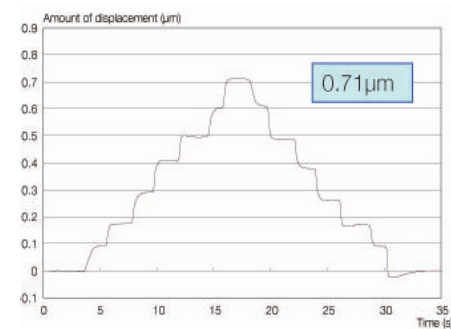

COLUMN TYPE THREE-FACE INDEPENDENT STRUCTURE

With Amada's unique three-face independent structure (the column moves front-to-back), the vertical, cross, and side-to-side axes are not dynamically affected by other moving axes, thus providing stable processing accuracy.

CAE structural analysis by 3D digital design

- Comprehensive analyses were conducted on the displacement of the structure caused by the machine's own weight, table movement, and column movement.
- The results of these analyses led to optimized rib placement, jack placement, and mass balance for repeatable precision.

HIGH-SPEED, NO-OVERHANG V-V SLIDING SURFACE

Superior straightness is achieved through the no-overhang design with a wide table base (Winstar SP: 52.75" [1,340 mm], Winstar: 55.11" [1,400 mm]) providing a maximum table stroke of 23.62" (600 mm) for the Winstar SP and 30.70" (780 mm) for the Winstar.

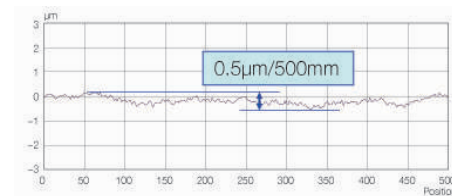

Table Straightness Accuracy (Winstar Sp)

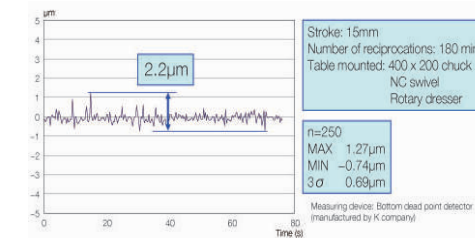

Table Reciprocation Accuracy (Winstar Sp)

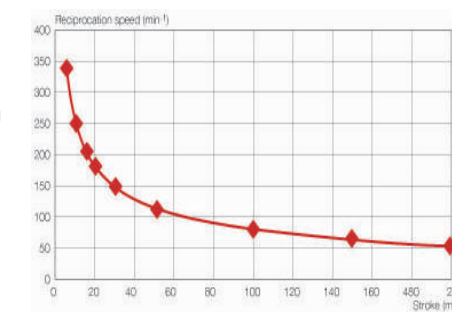
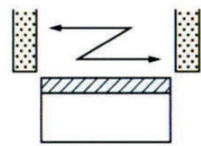
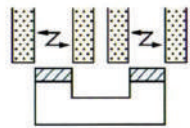

Table Reciprocation Speed (Winstar Sp)

Grinding Cycle (Standard)



Surface grinding—Traverse grinding is easy when it's digital. The front-back and side-to-side positions can be typed as dimensions or input by the electronic teaching button.



Traverse jump grinding—This cycle automatically jumps across a space between multiple surfaces on the same height. All surfaces can first be roughed, then all finished for more uniformity. (Optional on Winstar.)

Equal-depth slot grinding—Single or multiple

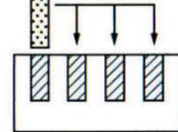

grooves can be easily input and ground. Equal pitch of 999 grooves or unequal pitch of 16 grooves can be set. (Optional on Winstar.)

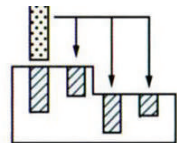

Unequal-depth slot grinding—Complex multiple grooves can be easily input and ground. Fifty grooves of unequal depth/unequal pitch can be set. (Optional on Winstar.)

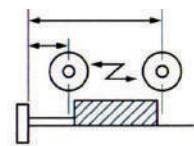

Table position setting—Table stroke position can be set on the screen. For workpieces on the chuck, end stroke positions can be set with the teaching button. The position setting screen enables changing centerline, length, and left and right position.

Taper mode—Set the taper angle, turn the handle, and the wheel moves on the angle. When re-grinding workpieces with unknown angles, the angle can be measured with two-point teaching. Using this function, any angle can be ground or dressed quickly, with no special fixtures.

R mode (radius)—Locate the front side and top of a workpiece and set the radius required. When you turn the handle, the wheel grinds a radius profile. The feed speed is controlled by the handle. There is no faster way to grind any radius.

Taper R—Grinding/dressing is performed by selecting six types of patterns and simply setting them. By setting rough or fine cut, grinding and wheel forming from a blank are possible.

Grinding Cycle (Optional)

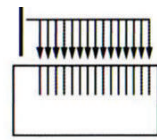

Tie bar grinding—Pitch data for multiple groove grinding can be edited easily. Finishing is done by grinding, leaving several μm each per groove. Creep grinding can also be supported. (Optional on Winstar.)

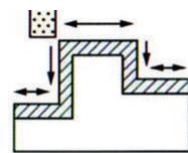

Pattern grinding—By combining the five most typical patterns, processing of complex shapes can be performed easily. Plunge/traverse can be combined for the most efficient grinding possible. (Optional on Winstar.)

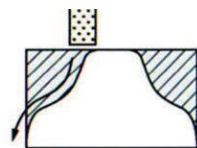

Pattern contouring—Contour grinding of simple shapes is as easy as inputting the required dimensions on the screen. Each shape is automatically displayed after input for operator review.

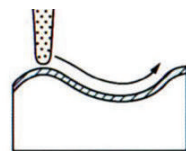

Contour grinding—Complex contour grinding can be performed by conversationally inputting figure data. A rough plunge cycle can be created and displayed automatically by the machine. G-code programs can also be uploaded and displayed for grinding.

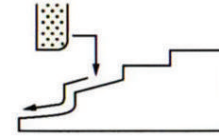

Terraced grinding—Step forms are combined and processed with ease. Forms can be set with five steps and four processes in one pattern. Dressing cycles have been built in, and grinding wheels can be dressed to radius or taper.

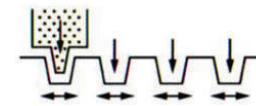

Trapezoidal groove grinding—Multiple-groove grinding can be performed on trapezoidal grooves. When the groove dimensions/pitch data are set, wheel forming and processing are performed automatically. Plunge, traverse, and contour grinding can be combined. Rough, medium, and fine processing are performed separately.

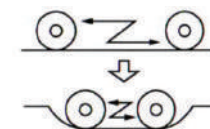
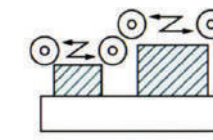
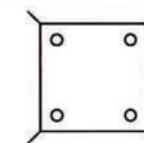

Table stroke—The speed switching function/plunge grinding/traverse grinding each have rough, medium, and fine grinding. Table speed and stroke length are adjusted automatically.



Multi-workpiece function—By setting multiple workpieces on the chuck, continuous grinding and processing can be performed. A maximum of five types of grinding data can be called up.



Air vent grinding (WAPS-WIN required)—Multiple grooves set on a plate can be processed while determining table strike position. This function processes by loading data created earlier with Amada's WAPS-WIN air vent cycles.

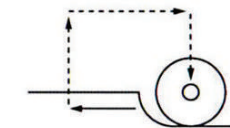

Hydraulic creep grinding—Using the table scale feedback, grinding can be performed setting table stroke shift speed to low speed. Both up-cut and down-cut are supported. Groove grinding software or tie bar grinding software is required.

Dress Cycle

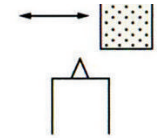

Straight dress—Dressing of wheel periphery is performed using a tabletop single-point dresser or high-speed disk dresser. This dressing cycle can be executed almost any time by the operator or a canned cycle.

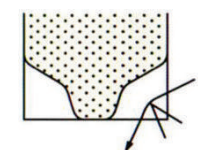

Pattern dress—Wheel forming is performed using a simple profile dresser, an NC profile dresser, or a high-speed disk dresser. Forms are created by simply inputting the dimensions required for basic shapes on the screen. This dressing cycle can be executed almost any time by the operator or a canned cycle.

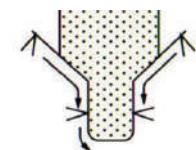

Profile dress—Wheel forming is performed on various shapes using a simple profile dresser, an NC profile dresser, or a high-speed disk dresser (oval fillister). Rough dress can also be performed. G-code programs can also be uploaded and displayed for dressing.

Overhead dress—Wheel periphery dress is performed using an overhead dresser. This dressing cycle can be executed almost anytime by the operator or a canned cycle.

Grooving dress—Wheel width is dressed to set values using a lateral face dresser and a high-speed wafer dresser. When the lateral face dresser is used, a back taper can be formed on the wheel.

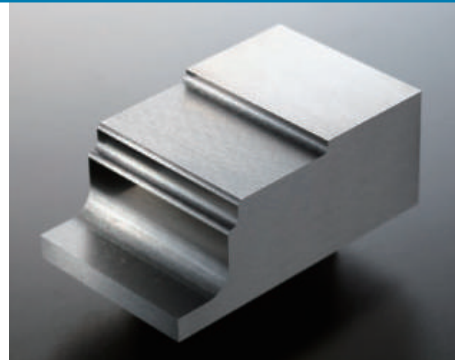

Contour Grinding

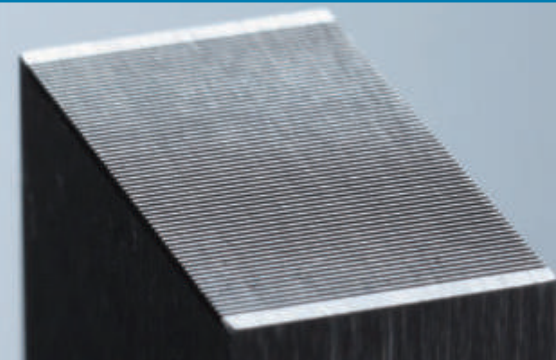

Angular Groove



Mirror Grinding

Unrivaled Grinding Precision by Design

STEP GRINDING ACCURACY

Grinding conditions

- Grinding wheel: CBN170 Ø7.87" x 0.39" x Ø1.25" (Ø200 mm x 10 mm x Ø31.75 mm)
- Table stroke: 4.72" (120 mm) 57 SPM
- Stock removal: 0.0008" (0.02 mm)
- Grinding processing time: 230 seconds
- Measuring device: Digital length measuring device (Nikon)

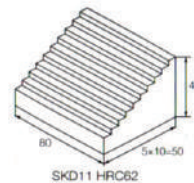

	CUMULATIVE ERRORS	PITCH ERROR
MINIMUM VALUE	-0.000008" (-0.0002 mm)	-0.000008" (-0.0002 mm)
MAXIMUM VALUE	0.00001" (0.0003 mm)	0.000008" (0.0002 mm)
MAXIMUM ERROR	0.00002" (±0.0005 mm)	

V GROOVE PITCH GRINDING PRECISION

Grinding conditions

- Grinding wheel: 89A400I (Tyrolit) 8.07" x 0.25" (V mountain forming) x Ø1.25" (Ø205 mm x 6.4 mm x Ø31.75 mm)
- Table stroke: 0.79" (20 mm) 150 SPM
- Number of grooves: 18
- Stock removal: 0.019" (0.5 mm)
- Times sparked out: 5
- Grinding processing time: 85 min. (including processing dress one time per groove)
- Measuring device: Non-contact laser 3D measuring device (Mitaka Kohki Co., Ltd.)

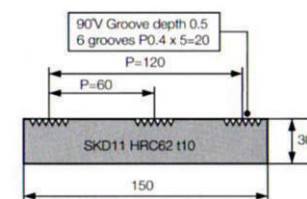

	CUMULATIVE ERRORS	PITCH ERROR
MINIMUM VALUE	-0.000012" (-0.0003 mm)	-0.000016" (-0.0004 mm)
MAXIMUM VALUE	0.000016" (0.0004 mm)	0.000016" (0.0004 mm)
MAXIMUM ERROR	0.000012" (±0.00035mm)	

MIRROR GRINDING

Grinding conditions

- Grinding wheel: D2000 Ø7.87" x 0.24" x Ø1.25" (Ø200 mm x 6 mm x Ø31.75 mm)
- Wheel speed: 900 RPM (peripheral speed: 1902 ft/min. (580 m/min.))
- Table stroke: 7.87" (200 mm)
- Table speed: 32.9'/min. (10 m/min.)
- Total grinding: 0.0003" (0.008 mm)
- Rough/fine: 0.00002"/0.000008" (0.0005 mm/0.0002 mm)
- Rough/fine in feed: 0.02"/0.008" (0.5 mm/0.2 mm) sync feeding
- Grinding time: 83 min.
- Measuring device: Surface roughness measuring device (Taylor Hobson)

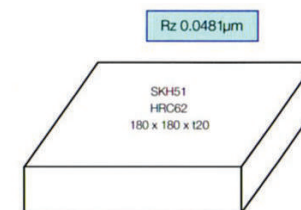

CONTOUR GRINDING

Grinding method

After forming the grindstone corner radius with the rotary dresser, contour grinding is performed.

Grinding conditions

- Grinding wheel: 1GB100 2 J 6VCSS Ø6.69" x 0.18" x Ø1.25" (Ø170 mm x 4.5 mm x Ø31.75 mm)
- Table stroke: 1.38" (35 mm) 120 SPM
- Number of grinding passes: 1
- Grinding time: 30 min.
- Measuring device: Non-contact laser 3D measuring device (Mitaka Kohki Co., Ltd.)

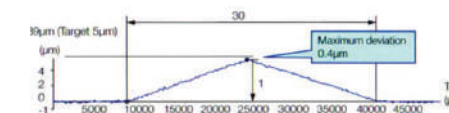

Machine Specifications

		WINSTAR SP	WINSTAR	
		Simultaneous 2 axis + 1 axis (hydraulic)	Simultaneous 2 axis + 1 axis (hydraulic)	
TYPE		Column type		
CAPACITY	Table working surface (length x width)	21.6" x 7.8" (550 x 200 mm)	24" x 10.6" (610 x 270 mm)	
	Table maximum side-to-side displacement	23.6" (600 mm)	30.7" (780 mm)	
	Column maximum front-back displacement	9.8" (250 mm)	13.3" (340 mm)	
	Spindle height (spindle C/L to table)	3.5"-15.7" (90-400 mm)	3.1"-17.7" (80-450 mm)	
	Chuck size (length x width x height)	19.6" x 7.8" x 3.9" (500 x 200 x 100 mm)	23.6" x 11.8" x 3.9" (600 x 300 x 100 mm)	
	Table height to floor	39.3" (1000 mm)		
	Maximum weight (chuck included)	330 lb (150 kg)	550 lb (250 kg)	
RECIPROICATION (RIGHT TO LEFT)	Manual	Handle feed rotation Normal	3.9" (100 mm)	
		Slight	0.19" (5 mm)	
	Automatic	Drive system	Hydraulic servo/mechanical manual pulse handle	Hydraulic servo/mechanical handle
		Feedrate	Normal 3-131 ft/min (1-40 m/min)	Hydraulic creep Low speed: 0.4"-7.8"/min (10-200 mm/min) High speed: 393"/min (10,000 mm/min)
	Automatic	Drive system	Servo valve + scale/hydraulic cylinder	Servo valve + scale/hydraulic cylinder
		Reciprocation speed (15 mm stroke)	200 min ⁻¹	200 min ⁻¹
	Minimum setting units		0.0004" (0.01 mm)	0.0004" (0.01)
	Position detection/scale resolution		Magnetically guided ABS scale/0.1 μm	Linear scale/1 μm
	Guide surface		W turcite	
	CROSS	Manual	Handle feed Magnification switch, x1, x10, x100, x400, automatic	One rotation 0.0004", 0.004", 0.04", 0.15" (0.01, 0.1, 1.0, 4.0 mm)
One scale			0.000004", 0.00004", 0.0004", 0.0015" (0.0001, 0.001, 0.01, 0.04 mm)	
Automatic		Drive system	Ball screw/mechanical manual pulse handle	
		Feedrate	Jog feed 0-15, 39, 78"/min (0-400 mm/min, 1000, 2000 mm/min)	0-15, 19, 39, 78"/min (0-400, 500, 1000, 2000 mm/min)
		Rapid traverse	157"/min (4000 mm/min)	
		Grinding feed	0.0004-157"/min (0.1-4000 mm/min)	
Minimum setting units		0.000010" (0.01 μm)		
Position detection/scale resolution		ABS linear scale/0.05 μm	Linear scale/0.05 μm	
Guide surface		Linear roller guide + slide (hybrid guide)		

Machine Specifications

		WINSTAR SP	WINSTAR	
		Simultaneous 2 axis + 1 axis (hydraulic)	Simultaneous 2 axis + 1 axis (hydraulic)	
WHEEL HEAD	Manual	Handle feed	One rotation 0.0004", 0.004", 0.04", 0.15" (0.01, 0.1, 1.0, 4.0 mm)	
			One scale 0.000004", 0.00004", 0.0004", 0.0015" (0.0001, 0.001, 0.01, 0.04 mm)	
	Automatic	Feedrate	Drive system	Ball screw/mechanical manual pulse handle
			Jog feed	3.9, 39, 78"/min (100, 1000, 2000 mm/min)
			Rapid traverse	78"/min (2000 mm/min)
			Grinding feed	0.004-19"/min (0.1-500 mm/min)
	Minimum setting units		0.000010" (0.01 μm)	
	Position detection/scale resolution		ABS linear scale/0.05 μm	Linear scale/0.05 μm
	Guide surface		Linear roller guide + slide (hybrid guide)	
	WHEEL	Outer diameter x width x bore diameter		Ø8 x 0.25-1 x Ø1.25" (Ø205 x 6.4-25 x Ø31.75 mm)
Spindle speed		500-5000 (inverter)		
HYDRAULIC	Hydraulic oil/lubrication oil/cooling oil		Hydraulic oil 40 (tank separated) Lubrication oil 12 (tank separated)	
	Hydraulic/cooling unit capacity (hydraulic oil not included)		286 lb (130 kg)	
	Oil cooler capacity (50/60Hz)		3.7/4.2 HP (2.8/3.2 kW)	
	Cooling medium		HCFC R410 (zero for ozone depletion potential)	
	Wheel spindle		5 HP (3.7 kW) (oil cooler)	
	Hydraulic pump		2 HP-4 P (1.5-4 kW-P)	
	Cross feed		1.3 HP (1.0 kW)	
MOTOR	Longitudinal feed		1.6 HP (1.2 kW)	
	Reciprocation feed		2.4 HP (1.8 kW) (β12is)	
	Automatic lubrication pump		25W	
	Cooling pump (50/60Hz)		0.4 shared with oil cooling pump (24/28.8L/min ⁻¹)	
	Cooling pump (24/28.8L/min ⁻¹)		0.4 shared with oil cooling pump (24/28.8L/min ⁻¹)	
POWER CAPACITY		12 kVA	14 kVA	
FLOOR SPACE	Width		106" (2700 mm)	
	Length		82" (2100 mm)	
	Height		77" (1975 mm)	
MACHINE TOTAL WEIGHT		8800 lb (4000 kg)	10,340 lb (4700 kg)	

Note: OP indicates an option.

Winstar SP Floor Space and Travel

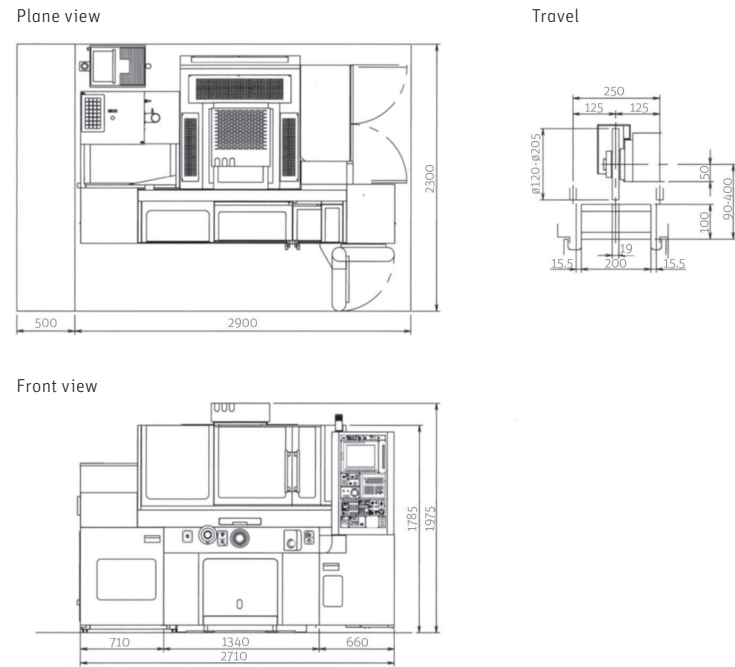

Winstar Floor Space and Travel

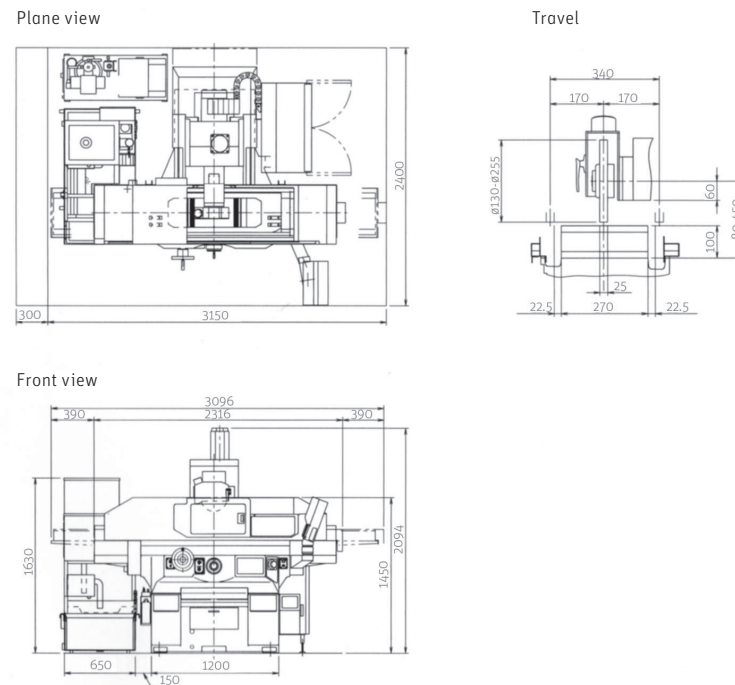

GRINDING TECHNOLOGY

Rotary Grinders

The high-accuracy ram design and servo motor-driven axes of Amada rotary grinders deliver high-precision grinding and smaller environmental impact. This series guarantees stable grinding through constant grind control.

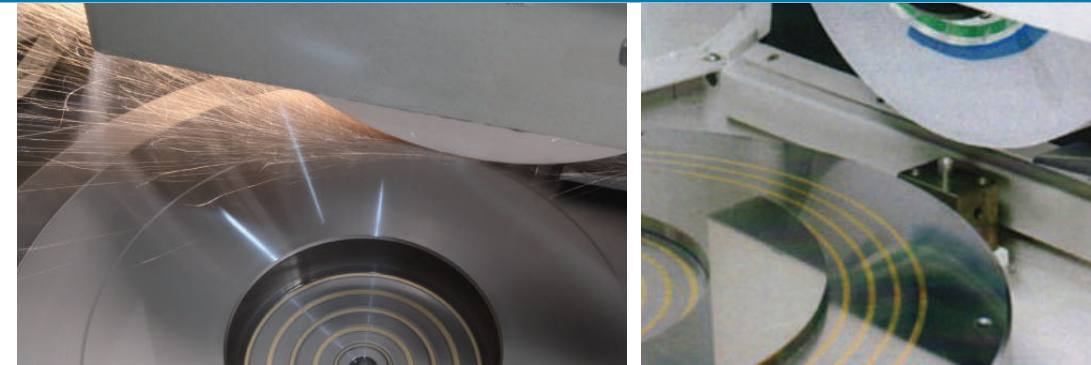

Surface Grinding

SSR5 Rotary Surface Grinder

The proven ram structure of this machine provides enhanced usability and exceptional efficiency while the enhanced feed axis speed shortens setup time. Linear guides on both vertical and horizontal axes improve straightness, while automatic table dressing enhances accuracy. Usability is improved with teaching functions on both the right and left sides, along with a manual pulse handle.

SSR5 Features

Three-Fold Productivity Rate Increase—The SSR5 has a three-fold productivity advantage compared to a horizontal-axis, square-table surface grinder with equivalent working area.

Low Environmental Load, Non-Hydraulic Pressure—Thermal displacement is remarkably reduced by an environment-responsive structure and non-hydraulic pressure NC specification, which also enables high accuracy.

Every Spindle Shifts to NC—Amada's dedicated rotary software allows automatic table dressing and automatic measurement functions.

Linear Guides—Both the vertical and horizontal axes feature linear guides for improved straightness.

Teaching Function—A teaching function on both the right and left sides, combined with a manual pulse handle, improves usability.

Automatic Table Dressing—Included as standard equipment, automatic table dressing functions enhance dimensional accuracy.

Servo Controlled Rotary Table—Enables superior surface finish over entire workpiece face through constant surface speed function.

Constant Surface Footage—Table rotation inverter enables synchronization of ram feed and table RPM. Feed speed and ram feed automatically increase to provide optimum surface footage across the face of the part for superior surface finish.

Machine Specifications

CAPACITY	Diameter of solenoid chuck valve		20" (508 mm)	
	Distance between chuck upper surface and grinding wheel lower surface		4.9" (125 mm)	
	Maximum swing in table cover		21.6" (550 mm)	
TABLE	Effective diameter of electromagnetic chuck		16.5" (420 mm)	
	Rotation speed/rotation speed range conversion number		50~300 min ⁻¹ /21 step	
	Vertical travel distance		7.4" (190 mm)	
	Maximum angle of inclination		±3°	
	Manual	Handle feed amount	Magnification Off, x0.1, x1, x10, x40	By a rotation 0.0004", 0.004", 0.04", 0.015" (0.01, 0.1, 1.0, 4.0 mm)
				By a scale 0.000004", 0.00004", 0.0004", 0.0015" (0.0001, 0.001, 0.01, 0.04 mm)
		Jog feed		328, 1640, 3280, 6560 ft/min (100, 500, 1000, 2000 m/min)
		Operation method		Jog lever pulse handle
	Automatic	Feed speed	Fast feed	78"/min (2000 mm/min)
			Grinding feed	0.004"-39" (0.1-1000 mm/min)
Minimum setting unit		0.000010" (0.0001 mm)		
RAM	Travel distance		13.1" (335 mm)	
	Manual	Handle feed amount	Magnification Off, x0.1, x1, x10, x40	By a rotation 0.0004", 0.004", 0.04", 0.015" (0.01, 0.1, 1.0, 4.0 mm [OP])
				By a scale 0.000004", 0.00004", 0.0004", 0.0015" (0.0001, 0.001, 0.01, 0.04 mm [OP])
		Jog feed		0~31", 39", 78", 157"/min (0~800, 1000, 2000, 4000 mm/min)
		Operation method		Jog lever pulse handle [OP]
	Automatic	Feed speed	Fast feed	196"/min (5000 mm/min)
			Grinding feed	0.004-196"/min (0.1~5000 mm/min)
	Minimum setting unit		0.000010" (0.0001 mm)	
	GRINDING WHEEL	Outside diameter x width x inside diameter		14" x 1.5" x 5" (355 x 38 x 127 mm)
		Rotation speed		0~2500 min ⁻¹
ELECTRIC DEVICE	Grinding wheel axis		10 HP/ 11 P (7.5 /11 kW-P)	
	For table rotation		2.4 HP (1.8 kW)	
	For vertical feed		1.8 HP (1.4 kW)	
	For ram actuation		1.6 HP (1.2 kW)	
	Automatic lubrication pump		0.03 HP (25 W)	
	Electric capacity		17 kVA	
Dimensions (length x width x height)		83" x 45" x 63" (2120 x 1154 x 1602 mm)		
DIMENSIONS / WEIGHT	Required floor space (including dust collection and coolant equipment and maintenance space)		110" x 82" (2800 x 2095)	
Machine total weight		5830 lb (2650 kg)		

Control Unit Specifications

CONTROL UNIT MODEL	F-0iT (FANUC)
CONTROLLED AXES	Single axis x 2, table rotation axis x 1 (X-axis: cross feed, Z-axis: vertical, B-axis: table rotation)

Standard Functions

- Automatic demagnetizing device
- Electromagnetic/permanent magnetic chuck supported
- Simplified permanent chuck demagnetizing function
- Stepless magnetic force adjustment knob
- Electric leakage breaker (sensed current: 30mA)
- 7.2-inch monochrome CD/MDI unit
- Dressing interval (in-grinding dressing)
- Z-axis (vertical) manual handle
- Manual reference point returning
- Stored stroke limit
- Table rotation override 0–100%
- Ram actuation override 0–100%
- Constant table rotation speed control
- Grinding wheel speed S command
- Self-diagnostic function
- Alarm and alarm history display
- Actual speed display
- Clock display
- Current position display
- Servo adjustment image
- Ram position teaching push button
- Operation time/number of parts display
- Chuck workpiece/workpiece reference push button
- Relative coordinate origin push button
- End message
- Buzzer (volume adjustable)
- Automatic table dressing function

Optional Functions

- X-axis (ram) manual handle
- Handle interruption
- Interruption dressing
- Running timer
- Warning light (1 color [yellow])
- Warning light (3 colors [red, yellow, green])
- Operation time display
- AC100V power outlet (2P)
- Imperial units available

Special Accessories

CHUCK	Electromagnetic chuck table (ring pole P = 8)
	Electromagnetic chuck table (star pole)
	Electromagnetic chuck table (star and ring pole)
	Vacuum adsorption chuck device (not including adapter plate)
COOLANT EQUIPMENT	Magnetic separator type dust collection and coolant device (150 liters) FW-152-GK
	Paper and magnetic separator type dust collection and coolant device (150 liters)
	Grinding fluid temperature control device
DRESSER	Electric dresser
SPINDLE	Balancing arbor
	Optional grinding wheel flange
	Gnding wheel width 50 mm
OTHER	Balance board
	Working lamp
	Specified color

External View

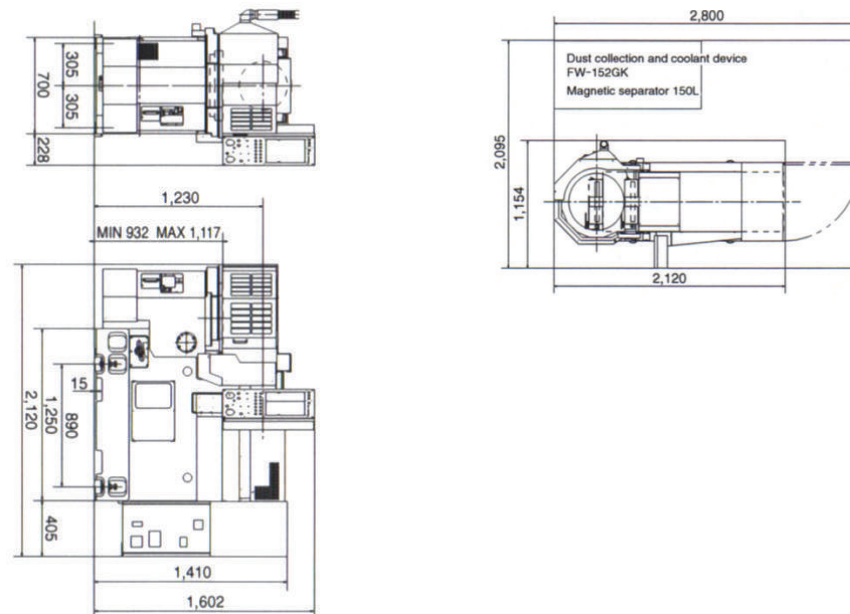

GRINDING TECHNOLOGY

CNC Surface Grinders

With the smallest footprint in their class, Amada surface grinders can boost your shop's productivity and efficiency. Integrated operation handles and a compact control panel allow for easy accessibility, while processing efficiency is enhanced by Amada's proven software.

Techster 52 and 52S

Techster 52 and 52S HIGH-SPEED CNC SURFACE GRINDERS



Techster 52 and 52S High-Capacity, Multi-Purpose High-Speed CNC Surface Grinders

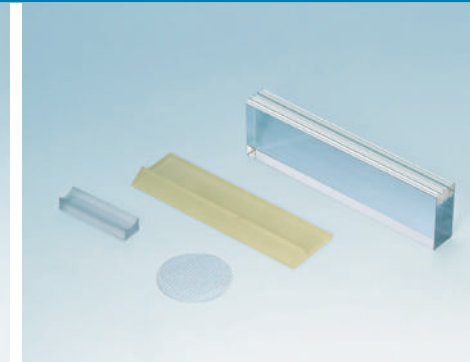
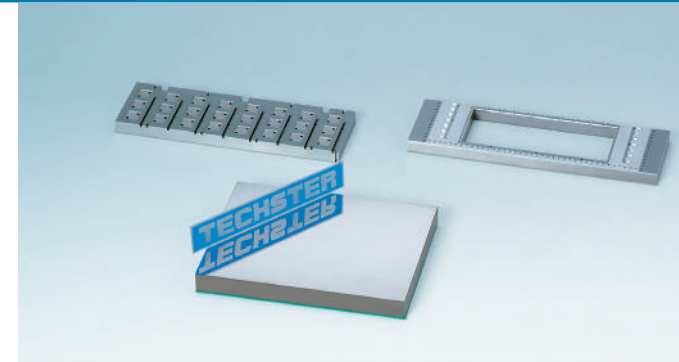

Techster 52 and 52S

Column—Built for high rigidity and exceptional straightness, the high column (4" higher than the Meister G3) provides greater flexibility in processing.

Table—V-V sliding surface structure provides high-precision operation while the rapid reciprocation rate allows for quick stock removal.

Bed and Saddle—The optimized rib layout and high-rigidity bed structure (with a low center of gravity) were developed through extensive structural analysis. The massive bed and thick saddle support heavier workpieces with outstanding precision and flatness.

Front-Side Operation—Axis movement can be controlled from the front of the machine, making column operations easy.

Wheel Spindle—A 5 HP (3.7 kW) spindle motor supports efficient stock removal with a 10" (254 mm) wheel. An 8" (203.2 mm) wheel is optional.

User-Friendly Control Panel—The space-saving control panel with Amada software improves overall efficiency.

- Large table traverse: 23.62" x 9.84" (600 mm x 250 mm)
- Table traverse way: double-V
- Servo valve-controlled traverse drive system

TECHSTER 52 CONTROL FANUC 32 IB

Two-axis simultaneous plus programmable table. The Meister operating system supports all canned cycle and G-code programming of the Meister series. Supports multiwork canned cycles and all dressing canned cycles.

Techster 64 and 64S

Techster 64 and 64S SADDLE TYPE CNC SURFACE GRINDERS

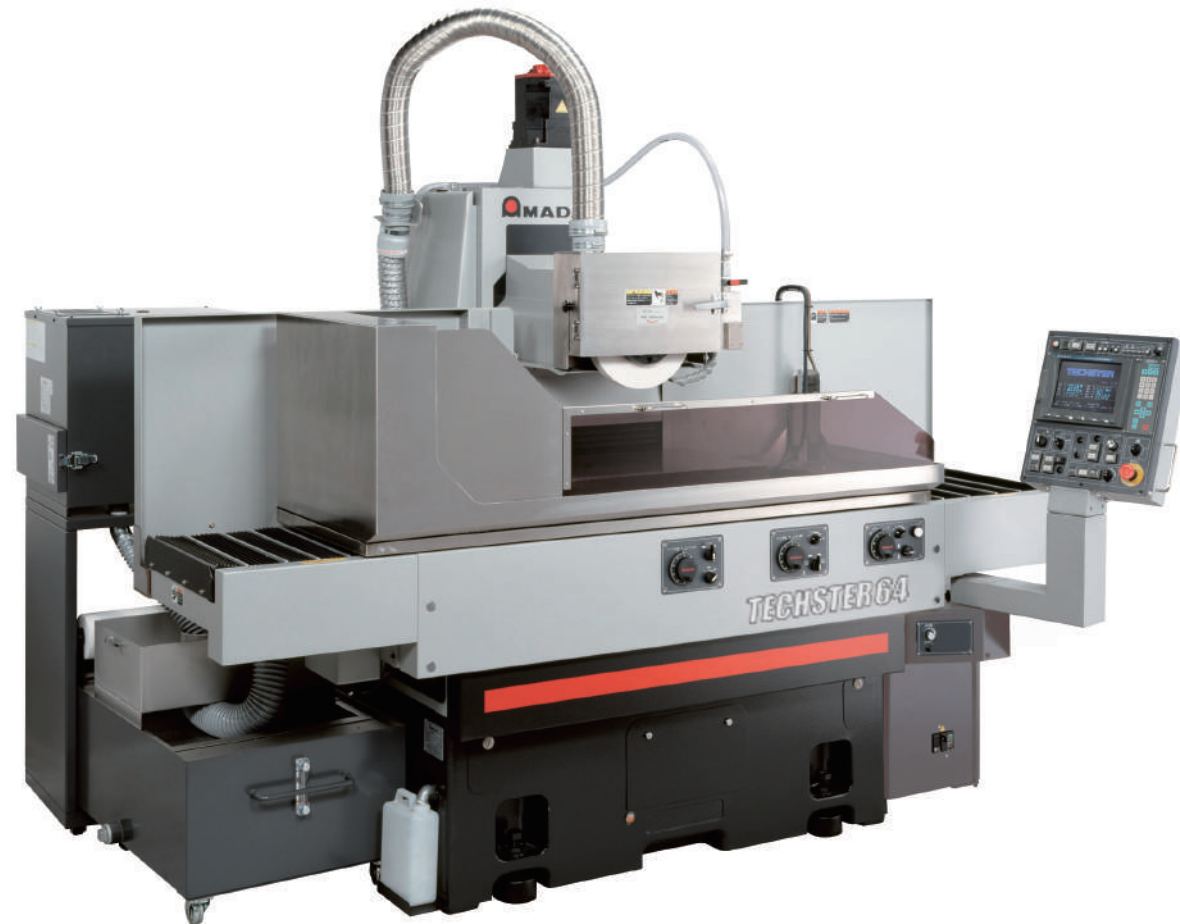

Techster 64 and 64S Saddle Type Precision Surface CNC Grinders



Mirror Finish Sample

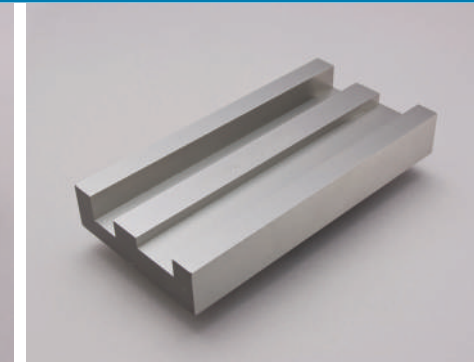

Slot Grinding Sample



Crowning Sample

Techster 64 and 64S

Column—The unique, isolated three-way sliding column on the Techster 64 and 64S was optimized through structural analysis to deliver maximum performance while requiring minimal floor space.

Table—The ball screw drive and no-overhang V-V sliding surface deliver high-precision operation in both high- and low-speed use. The non-hydraulic system is extremely environmentally friendly.

Bed and Saddle—The optimized rib layout and high-rigidity bed structure (with a low center of gravity) were developed through extensive structural analysis. The massive bed and thick saddle support heavier workpieces with outstanding precision and flatness.

Front-Side Operation—Axis movement can be controlled from the front of the machine, making column operations easy.

Wheel Spindle—The Ø4.93" (100 mm) high-rigidity spindle with quill ensures high-efficiency grinding.

User-Friendly Control Panel—The space-saving control panel with Amada software improves overall efficiency.

TECHSTER 64 CONTROL FANUC 32 IB

Three-axis control, two-axis simultaneous Meister operating system. Supports all canned cycles and G-code programming of the Meister series. Supports multiwork canned cycles and all dressing canned cycles. Supports creep feed canned cycle, providing high-precision, low-power creep feed.



CNC Profile Dresser

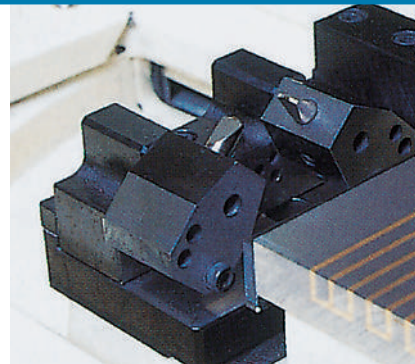

Simplified Profile Dresser



Automatic Measuring Device

Delivering a Wide Range of Processing Features and Dressing Systems

CNC Profile Dresser—The built-in servo motor swivels the dresser during wheel forming. With the simultaneous three-axis control of the machine’s X and Y, the dresser angle can be kept constant for normal line control. This makes it possible to dress a wheel with only one point of the dresser, providing high-precision profiles.

Simplified Profile Dresser—Two forming diamond tools are fitted to perform wheel form dressing at a fixed dresser angle.

Automatic Measuring Device (Touch Sensor)—After grinding to the specified dimensions during automatic (canned) cycle operation, this device measures the finished work and reference block, compares the results, and automatically performs follow-up grinding for correction if the workpiece size is out of tolerance. Tolerance for the pass/fail criteria can be set arbitrarily. As the machine’s Y-axis is used for measurement, the measuring resolution of this device is 0.000002" (0.05 µm).

HIGH-PRECISION SINGLE/TWIN ROTARY DRESSERS

- With a maximum 3,000 RPM, the high-precision single rotary dresser can be used for coarse dressing as well as for finish dressing of simple forms.
- The twin rotary dresser can accommodate two diamond rolls. One can be used for coarse and the other for fine dressing. Dresser width and form can also be changed to widen the scope of form dressing. The dresser spindle is supported on both sides for increased rigidity. It can also accommodate formed diamond rolls for wheel forming in plunge cut operations.

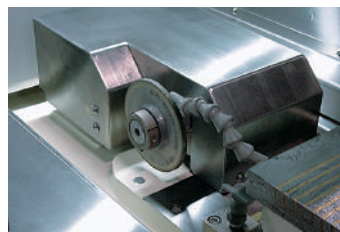

Machine Specifications

	TECHSTER 52	TECHSTER 52S		
CAPACITY	Table working surface (L x W)	21.6" x 7.8" (550 x 200 mm)		
	Max. longitudinal travel	23.6" (600 mm)		
	Max. cross travel	9.8" (250 mm)		
	Spindle center height from table	19.6" (500 mm)		
	Standard chuck size (L x W x H)	15.7" x 7.8" x 2.7" (400 x 200 x 70 mm)		
TRAVEL	Longitudinal feed	32-98 ft/min (1-30 m/min)		
	Max. no. of reciprocation (15 mm stroke)	150 min ⁻¹		
CROSS	Rapid cross feed (jog)	0-1300, 1600, 3200 ft/min (0-400, 500, 1000 m/min)	0-3200 ft/min (0-1000 m/min)	
	Handle feed	Per rev.	0.0004", 0.004", 0.04", 0.15" (0.01, 0.1, 1.0, 4.0 mm)	0.004", 0.15" (0.1, 4.0 mm) (OP)
		Per grad.	0.000004", 0.00004", 0.0004", 0.0015" (0.0001, 0.001, 0.01, 0.04 mm)	0.00004", 0.0015" (0.001, 0.04 mm) (OP)
	Minimum input increment	0.000010" (0.0001 mm)	—	
	Position detection system	Glass scale/0.05 µm (OP)	—	
	WHEEL HEAD	Rapid wheel head feed (jog)	3.9, 39"/min (100, 1000 mm/min) (2 steps)	
Handle feed		Per rev.	0.0004", 0.004", 0.04", 0.15" (0.01, 0.1, 1.0, 4.0 mm)	
		Per grad.	0.000004", 0.00004", 0.0004", 0.0015" (0.0001, 0.001, 0.01, 0.04 mm)	
Minimum input increment		0.000010" (0.0001 mm)	Manual 0.000010" (0.0001 mm) Counter 0.000039" (0.001 mm)	
Position detection system	Linear scale 0.05 µm (OP)	—		
WHEEL SPINDLE	Size (OD x width x bore)	Ø10 x 0.25-1 x Ø2" (Ø255 x 6.4-25 x Ø50.8 mm)		
	Wheel spindle speed	500-5000 min ⁻¹		
	Motor requirement	5 HP-2 P (3.7-2 kW-P)		
NC CONTROL AXIS	Singly 2 axis	Singly 1 axis		
FLOOR SPACE (W X L X H)	88" x 72" x 78" (2240 x 1840 x 2000 mm)	88" x 69" x 78" (2240 x 1770 x 2000 mm)		
MACHINE NET WEIGHT	5280 lb (2400 kg)			

*The table speed depends on work load on the table.

Machine Specifications

		TECHSTER 64	TECHSTER 64S	
CAPACITY	Table working surface (L x W)	27" x 15.7" (700 x 400 mm)		
	Max. longitudinal travel	30.7" (780 mm)		
	Max. cross travel	17.7" (450 mm)		
	Spindle center height from table	19.6" (500 mm)		
	Standard chuck size (L x W x H)	23.6" x 15.7" x 3.9" (600 x 400 x 100 mm)		
TRAVEL	Longitudinal feed	3.2-98 ft/min (1-30 m/min)		
	Max.no. of reciprocation (15 mm stroke)	150 min ⁻¹		
CROSS	Rapid cross feed (jog)	0-1300, 1600, 3200, 6400, 9800 ft/min (0-400, 500, 1000, 2000, 3000 m/min)	16-9800 ft/min (5-3000 m/min) (21 steps)	
	Handle feed	Per rev.	0.0004", 0.004", 0.04", 0.4" (0.01, 0.1, 1.0, 10.0 mm)	0.0004", 0.004", 0.04", 0.15" (0.01, 0.1, 1.0, 4.0 mm) (OP)
		Per grad.	0.000004", 0.00004", 0.0004", 0.0015" (0.0001, 0.001, 0.01, 10.0 mm)	0.000004", 0.00004", 0.0004", 0.0015" (0.0001, 0.001, 0.01, 0.04 mm) (OP)
	Minimum input increment	0.0" (0.0001 mm)	—	
	Position detection system	Glass scale/0.05 μm (OP)	—	
	Rapid wheel head feed (jog)	3.9, 39"/min (100, 1000) (2 steps)		
WHEEL HEAD	Handle feed	Per rev.	0.0004", 0.004", 0.04", 0.15" (0.01, 0.1, 1.0, 4.0 mm)	
		Per grad.	0.000001", 0.00001", 0.0001", 0.0015" (0.0001, 0.001, 0.01, 0.04 mm)	
	Minimum input increment	0.000010" (0.0001 mm)	Manual 0.000010" (0.0001 mm) Counter 0.000039" (0.001 mm)	
Position detection system	Linear scale 0.05 μm (OP)	—		
WHEEL SPINDLE	Size (OD x width x bore)	Ø14 x 1.5-2 x Ø5" (Ø355 x 38-50 x Ø127 mm)		
	Wheel spindle speed	1500/1800 min ⁻¹ (50/60Hz)		
	Motor requirement	5 HP-4P (3.7-4 kW-P)		
NC CONTROL AXIS		Simultaneously 2 axis	Singly 1 axis	
FLOOR SPACE (W X L X H)		94" x 88" x 81" (2400 x 2240 x 2080 mm)	96" x 85" x 81" (2440 x 2180 x 2080 mm)	
	MACHINE NET WEIGHT	8800 lb (4000 kg)		

*The table speed depends on work load on the table.



GRINDING TECHNOLOGY

Mid-Sized CNC Surface Grinders

Built to deliver consistent repeatability on larger projects, the Techster Series grinders feature high-rigidity beds with low centers of gravity and tables without overhangs, so you can handle heavy, high-accuracy grinding with ease.

Techster 84 • 104 • 126

Techster Series COLUMN TYPE PRECISION SURFACE GRINDERS



Techster Series 84, 104, and 126 Column Type Precision Surface Grinders



Ball Screw Drive Table



Operator Panel

Techster Series Features

Economy and Ecology

- The Techster 84, 104, and 126 grinders feature ball screw drive tables as standard. This non-hydraulic drive unit reduces noise and environmental burdens, reducing power consumption while delivering high speed and accuracy for reduced grinding times.
- The vertical axis has a linear guide way with 0.000004" (0.1µm) following for the mirror.
- A powerful 20 HP (15 kW) spindle motor delivers outstanding performance. (Optional on Techster 126.)

Techster Control

- Control FANUC Windows interface.
- Three-axis control, two-axis simultaneous.
- Meister operating system-compatible.
- Supports all canned cycles and G-code programming of Meister series.
- Supports multiple work cycles.
- Supports all dressing cycles.
- Supports creep feed canned cycle.
- Provides high precision mid-power creep feed.

Original Designed Structure

- The high-precision structure has increased mass for high rigidity.
- A long stroke cross axis on a T-type solid bed structure ensures maximum straightness over the life of the machine.
- A high-rigidity, C-type column reduces overhang on the wheel head.
- Table movement is fully guided by V-V slideways.

Safe and User-Friendly

- PC-type NC touchscreen.
- Interactive programming software.
- Three types of machine coverings.
- Supports all dressing cycles.

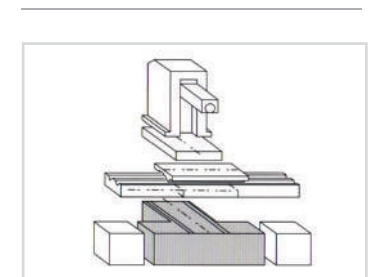

T-Frame Construction

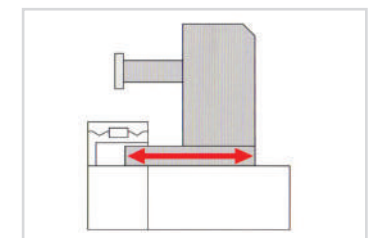

Zero Overhang



User-Friendly Interactive Programming Software



On-Board Measuring Touch Probe



CNC Swiveling Rotary Dresser

Wide Range of Optional Features

- Newly developed original software provides more efficient grinding.
- A quick and accurate on-board measuring device ensures the tightest tolerances are met.
- An automatic wheel balancer is available for Techster 104 and 126 grinders. This measuring instrument adjusts the balance of the wheel and spindle as an integral unit—perfect balancing improves the ground surface roughness.
- Each available dresser has an automatic dressing cycle program:
 - CNC swivel rotary dresser
 - High-speed rotary dresser
 - Single diamond profile dresser
 - Straight dresser

The Techster 126 in Action

The Techster Series' combination of environmental efficiency and grinding accuracy makes mid-sized jobs easy.

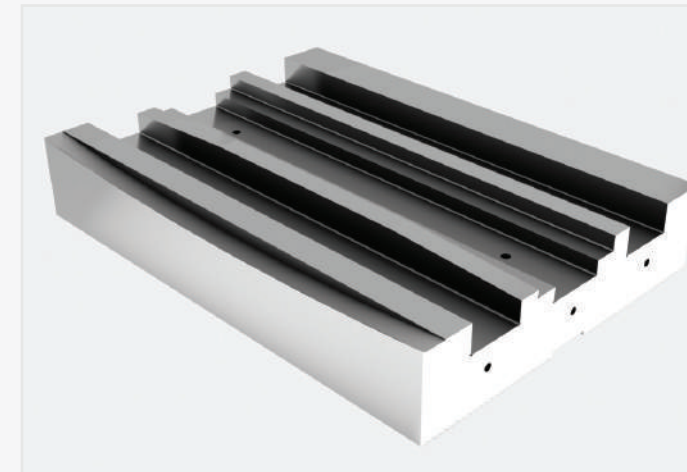

Machine Component

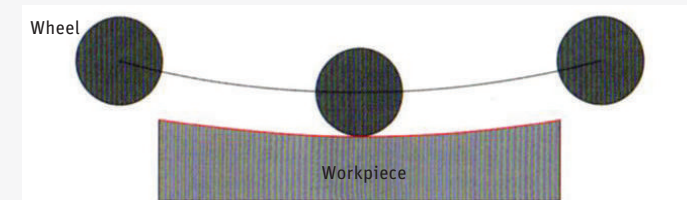

Crowning Grinding (Concave Curving)

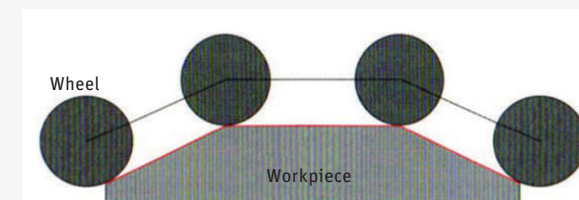

Crowning Grinding (Slant and Straight)

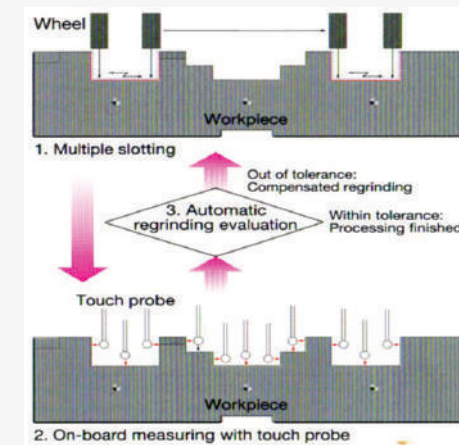

Programmable Measuring and Auto Re-Grinding



Mirror Finishing Example

GRINDING ACCURACY

15 pieces surface grinding	Parallelism 2.0 μm
Longest work surface grinding	Straightness 3.0 μm
Face grinding	Straightness 3.0 μm

Machine Specifications

	TECHSTER 84	TECHSTER 104	TECHSTER 126	
CAPACITY	Max. longitudinal travel	39.3" (1000 mm)	47.2" (1200 mm)	59" (1500 mm)
	Max. cross travel	17.7" (450 mm)	18.1" (460 mm)	25.9" (660 mm)
	Max. spindle center height from table	19.6" (500 mm)	29.5" (750 mm)	33.4" (850 mm)
	Standard chuck size (L x W x H)	31.4" x 15.7" x 3.9" (800 x 400 x 100 mm)	39.4" x 15.7" x 3.9" (1000 x 400 x 100 mm)	47.2" x 23.6" x 3.9" (1200 x 600 x 100 mm)
TRAVEL	Longitudinal feed	10-131 ft/min (3-40 m/min.)		
	Max. no. of reciprocation (15 mm stroke)	120 min ⁻¹		
	Traverse guide way/drive	V-V sliding guide way/ball screw direct drive		
CROSS	Rapid cross feed (jog)	0-15, 19, 78, 196 ft/min (0-400, 500, 2000, 5000 m/min.)		
	Handle feed	Per rev.	0.0004", 0.004", 0.04", 0.4" (0.01, 0.1, 1.0, 10.0 mm)	
		Per grad.	0.000004", 0.00004", 0.0004", 0.004" (0.0001, 0.001, 0.01, 0.1 mm)	
	Minimum input increment	0.000010" (0.0001 mm)		
	Position detection system	Linear scale/deviation: 0.05 µm (OP)		
	Cross guide way/drive	Linear roller guide way/ball screw direct drive		
WHEEL HEAD	Rapid wheel head feed (jog)	3.9, 78"/min (100, 2000 mm/min)		
	Handle feed	Per rev.	0.0004", 0.004", 0.04", 0.157" (0.01, 0.1, 1.0, 4.0 mm)	
		Per grad.	0.000004", 0.00004", 0.0004", 0.0015" (0.0001, 0.001, 0.01, 0.04 mm)	
	Minimum input increment	0.000010" (0.0001 mm)		
	Position detection system	Linear scale/deviation: 0.05 µm (OP)		
WHEEL SPINDLE	Size (OD x width x bore)	Ø14 x 1.5-2 x Ø5" (Ø355 x 38-50 x Ø127 mm)	Ø14 x 1.5-2 x Ø5" (Ø355 x 38-50 x Ø127 mm)	Ø20 x 38-50 x Ø5" (Ø510 x 38-50 x Ø127 mm)
		Wheel spindle speed	300-2500 min ⁻¹	300-2500 min ⁻¹
	Motor requirement	10HP-4P (7.5-4 kW)	10HP-4P (7.5-4 kW)	15HP-6P (11-6 kW)
			11-6 kW (option)	15-6 kW (option)
NC CONTROL AXIS	Simultaneous 2 axis + Table 1 axis			
FLOOR SPACE (W X L X H)	133" x 102" x 81" (3380 x 2615 x 2075 mm)	151" x 131" x 98" (3850 x 3330 x 2495 mm)	179" x 142" x 109" (4550 x 3630 x 2780 mm)	
MACHINE NET WEIGHT	11,000 lb (5000 kg)	16,500 lb (7500 kg)	27,500 lb (12,500 kg)	

*The table speed depends on work load on the table.

Dimensions

	TECHSTER 84	TECHSTER 104	TECHSTER 126
WIDTH	133" (3380 mm)	151" (3850 mm)	179" (4550 mm)
DEPTH	102" (2615 mm)	131" (3330 mm)	142" (3630 mm)
HEIGHT	81" (2075 mm)	98" (2495 mm)	109" (2780 mm)
OPENING		61" (1555 mm)	83" (2115 mm)
TO TOP OF COVER		86" (2190 mm)	98" (2490 mm)
REQUIRED FLOOR PLAN	29ft ² (9 m ²)	39ft ² (12 m ²)	52ft ² (16 m ²)



GRINDING TECHNOLOGY

Multi-Function Grinding Centers

The world-renowned precision that has made Amada Machine Tools a leader in grinder manufacturing is now available in a multifunction grinding center. The new MX 150 combines five-axis milling, turn milling, and grinding functions in one easy-to-use machine. Complete processing—from rough stock to finish surfaces—can be done in a single chucking, and the grinding feature offers super-fine finishing suitable for plastic injection molding and medical applications.



MX-150 Multi-Function Grinding Center



Powerful CNC Control



Automatic Tool Changer

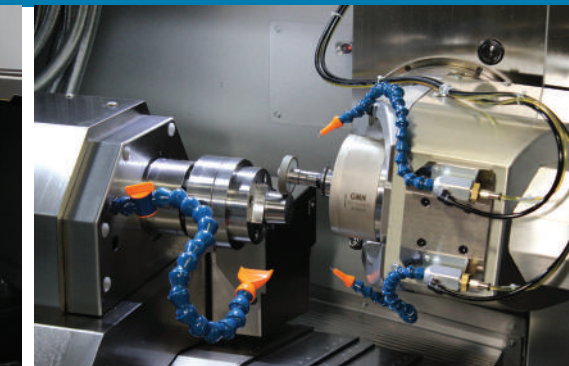

OD Taper Grinding

MX-150 Features

Outstanding Functionality

- Capacity to machine a wide variety of workpieces.
- Five-axis motion can be performed with a higher level of accuracy thanks to an independent structure that prevents incremental positioning errors from the pivot point.
- Very high machining accuracy is achieved by a design concept equivalent to that of a grinding machine.
- Positioning accuracy: Linear axis $\pm 1 \mu\text{m}$ or less, rotary axis $\pm 2''$ or less.

Turn Milling

- Workpieces can be machined at high speed by turning both the workpiece and the tool.
- Intermittent cutting provides a cooling effect and consequently improves tool life.

Integrated Grinding Process for Finish Machining

- The machine enclosure and way covers are designed with the grinding function in mind. This improves machine reliability and operator safety by keeping the cutting fluids contained within the machining area.
- Cutting fluid filter system designed exclusively for grinding (optional).
- The magnetic separator and the cyclone filter remove sludge and wheel grit.
- In-machine rotary dresser (optional).
- Grinding using a vitrified grinding wheel is possible.



Tool Magazine

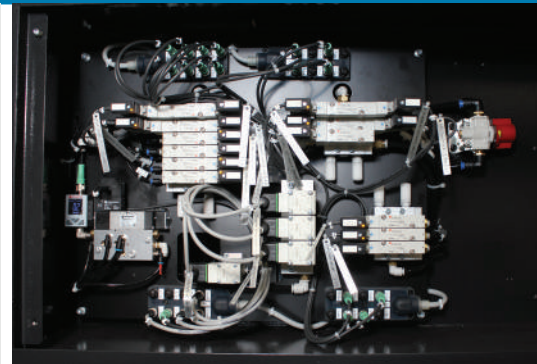

High Visibility for Easy Maintenance

Additional Features for Maximum Versatility

- Maximum workpiece: 6" x 7.8" (150 mm x 200 mm).
- Powerful 42,000 RPM, 20 HP (15 kW) spindle handles a wide range of tasks, from milling hard-to-machine materials to micromachining with small-diameter tools.
- Sub-micron precision for maintaining the tightest tolerances.
- Full enclosures contain cutting fluids to protect the operator and the equipment.



Semi-Dry Lubrication System for Milling



Easy Access to Regulators

MX-150 Machine Specifications

CAPACITY	Maximum workpiece size (including jig)	5.906" x 7.874" (150 x 200 mm)
	Maximum weight (including chuck - jig)	22.046 lb (10 kg)
TRAVEL	X axis (right/left)	13.78" (350 mm)
	Y axis (back/forth)	11.811" (300 mm)
	Z axis (up/down)	15.748" (400 mm)
	A axis (work rotation axis)	360°
	B axis (tool rotation axis)	110°
LINEAR AXIS (X/Y/Z AXIS)	Rapid traverse	131.234 ft/min (40 m/min)
	Maximum cutting feed	98.425 ft/min (30 m/min)
	Minimum setting unit	.000004" (0.0001 mm)
WORK ROTATION AXIS (A AXIS)	Rapid traverse	300 rev/min (at rotation control: 1000)
	Maximum cutting feed	250 rev/min
	Minimum setting unit	0.0001°
TOOL ROTATION AXIS (B AXIS)	Rapid traverse	55 rev/min
	Maximum cutting feed	25 rev/min
	Minimum setting unit	0.0001°
MAIN SPINDLE	Maximum rotation speed	42,000 rev/min
	Maximum output	20.115 HP (15 Kw)
	Maximum torque	6 μm
	Lubrication	Oil air lubrication
	Tool interface	HSK-E40
	No. of ATC	20
	Maximum tool diameter	1.969" (50 mm)
	Maximum tool length	5.906" (150 mm)
Maximum weight	2.205 lb (1 kg)	
FLOOR SPACE (W X D X H)	86.614" x 130.315" x 81.102" (2200 x 3310 x 2060 mm)	
MACHINE NET WEIGHT	11,024 lb (5000 kg)	

See Amada Grinders at Work



The AMTA Technical Center was created to provide a unique environment for visitors to experience the latest manufacturing technology in action. This stunning 40,000-square-foot facility houses the latest Amada technology in each product group. Much more than just an exhibit, every machine, automation accessory, and software program in the facility is fully operational and ready to empower customers to solve their most challenging manufacturing applications.



At **AMADA MACHINE TOOLS AMERICA**, we're committed to your success. More than just a provider of precision metalworking solutions, we're a partner who can help you meet the advanced engineering and manufacturing challenges unique to your industry. Together, we can create the right solution to meet your needs today and empower you to build your business for the future.

The information in this catalog is as of August 2013. Specifications and other contents are subject to change without notice.

There may be differences between the specifications described in this catalog and the Amada products actually shipped. Please ask our staff for more detail.

The products in the catalog may be subject to the provisions of foreign exchange and the Foreign Trade Law. When exporting cargo subject to such controls, permission pursuant to regulation is required. Please contact our business representative in advance when exporting products overseas.

When using our products, safety equipment is required depending on the operational task.

For safe and correct operation, ensure thorough reference to the Instruction Manual prior to operation.

The cutting performance data in this catalog may be affected by temperature, the cutting materials, tool materials, and cutting conditions, etc. Please note that such data are not guaranteed.

AMADA MACHINE TOOLS AMERICA, INC.

www.amadamt.com

MAIN OFFICE

2324 Palmer Drive
Schaumburg, IL 60173
tel (847) 285-4800
fax (847) 519-2127

BRANCH OFFICE

7025 Firestone Blvd
Buena Park, CA 90621
tel (714) 739-2111

BANDSAW AND BLADE BUSINESS

bandsaws@amadamt.com
bladeorders@amadamt.com
bandsawparts@amadamt.com
bandsawservice@amadamt.com

GRINDER BUSINESS

grinders@amadamt.com
grinderparts@amadamt.com
grinderservice@amadamt.com