

SOLUTION



COMPLETE
METALWORKING
SOLUTIONS

(800) 991-4225
www.ahbinc.com
ISO Certified
customerservice@ahbinc.com

VT SERIES

VT3850A (380APC) • VT3850S (380APCS)



Also Available In ▶
MARVEL CLASSIC



CAPACITY: 15" X 20"
1.25" BLADE WIDTH



AMADA[®]
AMADA MACHINERY AMERICA, INC.

DIRECT FORCE SENSING ELECTRIC BALL SCREW FEED

VT SERIES **VT3850**

VT3850A (3850APC) = AUTOMATIC
VT3850S (380APCS) = SERVO BAR FEED OPTIONAL

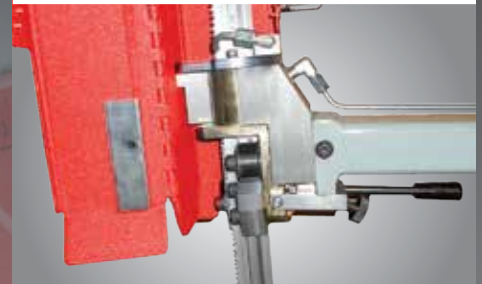

Also Available In
MARVEL CLASSIC



MAXIMUM LOAD CAPACITY
500 POUNDS/FOOT,
UP TO A MAXIMUM OF
7,000 LBS TOTAL WEIGHT.

FIRST SECTION DEAD ROLLER CONVEYOR W/ MANUAL LENGTH GAUGE ▶

Dead Stop, Tilting Type Gauge;
manually operated. Runs along tape
and rail fastened to front side of
Roller Table. Gauge can be locked in
place for gauging and tilted out of the
way to permit work passage.



STANDARD FEATURES

- **SPEED RANGE:** 60 to 400 FPM (18 to 122 m/min). Blade speed can be automatically set when material is selected.
- **TILTING COLUMN:** For miter cutting up to 60° left and right of vertical. Variable speed, inverter driven, electronic tilt- Includes encoder feedback and touch screen display & control, for precision miter positioning. Electrically powered with encoder feedback and PC3 Controller.
- **0° - 3° CANTED COLUMN:** Adjustable 0 or 3-degree forward approach angle, for notching, or increased efficiency in cutting of structural materials. Capacity at 0° 15" x 20". Capacity at 3° 14.5" x 20".
- **JAMMED BLADE PROTECTION:** Automatically senses resistance as the column returns and stops to prevent blade damage.
- **BLADE GUIDE:** Patent pending Rotating Easy Load Combination Carbide and Ball Bearing Roller guides with self-tensioning.
- **FLUSHING HOSE:** Washes chips from hard to get at places reducing clean-up time.
- **VICES:** Hydraulic 60° jaws are standard with Optional Variable Vise Pressure as well as square jaws.
- **PC3 PROGRAMMABLE CONTROL®:** Provides a Programmable Logic Control Unit with a 9" color, touch screen display. The control features graphical part programming with memory for up to 500 jobs and parts, as well as a material selection chart and customizable material library.
- **AUTOMATIC BAR FEED:** 48" double ball screw bar feed design with following support rollers, shuttle speeds up to 70fpm and repeatability tolerances of +/- .005". The VT3850 bar feed uses preloaded recirculating linear guides.
- **EAGLE BEAK VTR BLADE:** Eagle Beak VTR blade 16' long x 1.25" wide, with 3/6 tooth pitch. This is the standard blade that is included with machine purchase.

MOST POPULAR OPTIONAL FEATURES

- **F3: OUTBOARD VISE**
- **F12: WORK LIFT ROLLER**
- **SGA1: SMART GUIDE ARM**
- **F4: SECOND MACHINE VISE**
- **M9A: VARIABLE VISE PRESSURE**
- **PC3SBN: BULLET NOSE FEATURE**
- **F055L: DEAD ROLLER CONVEYORS**
- **M4A: OPPOSITE HAND WORK ENTRY**
- **M8M/M8: CHIP CONVEYOR - MANUAL or POWERED**
- **F8/F8A: HYDRAULIC HOLD DOWNS - MACHINE/SHUTTLE**

*Pictures may include some optional equipment.

*Some safety equipment may have been removed or opened to illustrate products clearly and must be in place, and functioning, prior to operation.



TILTING COLUMN



3° CANTED COLUMN



VICES



M8M: MANUAL CHIP CONVEYOR



M9A: VARIABLE VISE PRESSURE



F8A: SHUTTLE HOLD DOWN

PRODUCT SPECIFICATIONS & DIMENSIONS

MARVEL SERIES VT3850 (380APC)

Capacity	Rectangular Capacity	Round Capacity
Nominal 0° Cant	15" x 20" (381 mm x 508 mm)	15" (381 mm)
Blade 45° Right	15" x 14" (381 mm x 355 mm)	14" (355 mm)
Blade 60° Right	15" x 9.25" (381 mm x 235 mm)	9.25" (235 mm)
Blade 45° Left	15" x 13.25" (381 mm x 336 mm)	13.25" (336 mm)
Blade 60° Left	15" x 8" (381 mm x 203 mm)	8" (203 mm)
Capacity 3° Forward Cant	14.5" x 20" (368 mm x 508 mm)	14.5" (368 mm)
Blade 45° Right	14.5" x 13.5" (368 mm x 343 mm)	13.5" (343 mm)
Blade 60° Right	14.5" x 8.75" (368 mm x 222 mm)	8.75" (222 mm)
Blade 45° Left	14.5" x 12.75" (368 mm x 324 mm)	12.75" (324 mm)
Blade 60° Left	14.5" x 7.75" (368 mm x 197 mm)	7.75" (197 mm)

Blade Drive	5 H.P.
Speed Range	60 to 400 FPM (18 to 122 m/min)
Feed Force	0 - 300 lbs (0 - 1335 N)
Blade	16' (4877 mm) long x 1.25" (32 mm) wide, .042" (1.07 mm)
Blade Tension	35,000 psi max (241 MPa)
Main Drive	5 H.P. (3.75 kW)
Coolant Pump	1/8 H.P. (.1 kW)
Hydraulic Pump	2 H.P. (1.5 kW)
Hydraulic Oil	13 gallons (49 liters)
Cutting Fluid	26 gallons (98 liters)

VT3850A (380APC)

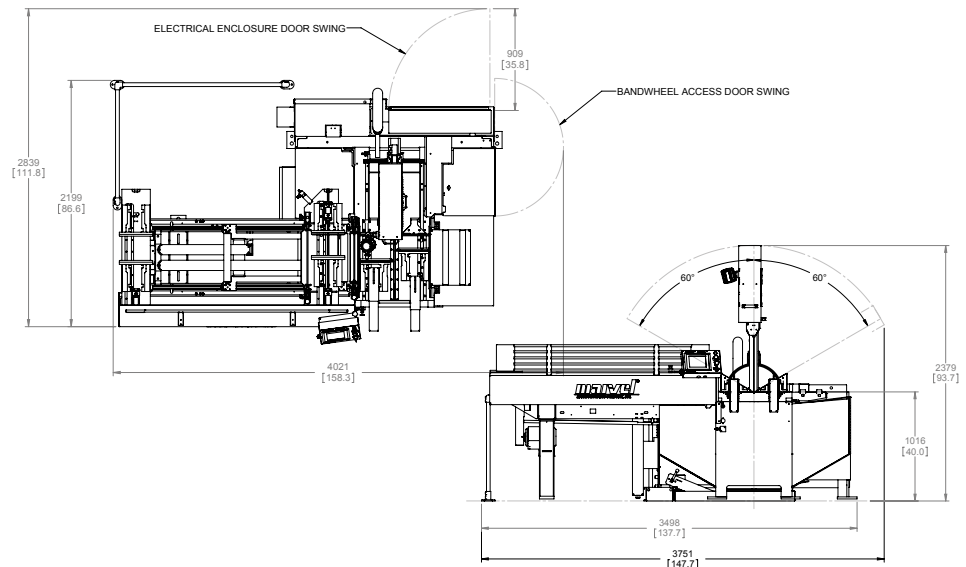

⚠ Before using this product, please read the operator's manual carefully and follow all applicable instructions.
 • When using our products, safety equipment is required depending on the operational task.

- * Specifications, appearance and equipment are subject to change without notice by reason of improvement.
- * Please use the machine model name as VT3850S or VT3850A, when applying for administration applications. Examples: installation report, export, and financing, ect. To make this catalog more legible, we have inserted hyphens in the model name such as 380A-PC3-60 and 380M-60.
- * For any inquires, please contact local Amada Machinery America, Inc. office.
- * The red color model name is reference for the MARVEL CLASSIC color scheme, which is an option.

© AMADA MACHINERY AMERICA, INC. All Rights Reserved.