



# Athens

Machine Builders

Quality Machines for Metal Working



Model CTR-12-12/2.6/26

## ATHENS CTR SERIES

Patents Pending

### 4 Roll Cone Bending Machine



COMPLETE  
METALWORKING  
SOLUTIONS

(800) 991-4225

[www.ahbinc.com](http://www.ahbinc.com)

ISO Certified

[customerservice@ahbinc.com](mailto:customerservice@ahbinc.com)

CTR-2013

**Athens CTR Series Cone Rolling Machine** was designed to meet the needs of various industries that require the rolling of symmetrical and asymmetrical cones rapidly and accurately. Machines are designed with typical Athens simplicity, strength, and accuracy using many off the shelf components. Although the design is new there are already many satisfied customers. Among them are :

**Honeyville Sheet Metal Works—**  
Asymmetrical/Symmetrical Cones for Grain Handling Distribution Heads

**Urshell Laboratories—**  
Food Processing Machinery

**Magic Valley Heli-Arc & Mfg.—**  
Pumping Equipment to Pump Live Fish

**Contec—**Transport Concrete Mixers

**Titan Flow Control—**  
Inline Strainer for Process Machinery



Vertical/Horizontal unit for concrete mixer drums



In feed area, notice work piece location pointer



Stainless steel components for food choppers & shredders



Asymmetrical cones for grain handling



Finished work piece

*Athens*  
Machine Builders



Spencer, Tennessee  
USA



Rapid roll change feature



Notice the forming quality of these straight sided asymmetrical cones

**Sizes & Capacities**

Machines are designed for rolling capacities down to 0" on small end, material thickness from 26 gauge to 1/4" in mild steel, stainless steel, AR Plate- solid & perforated from 9" to 12' in length.



Storage caddy & tool chest for additional roll sets



Tool chest open showing extra bearing holders & changing tools

**Cone Forming Cycle**

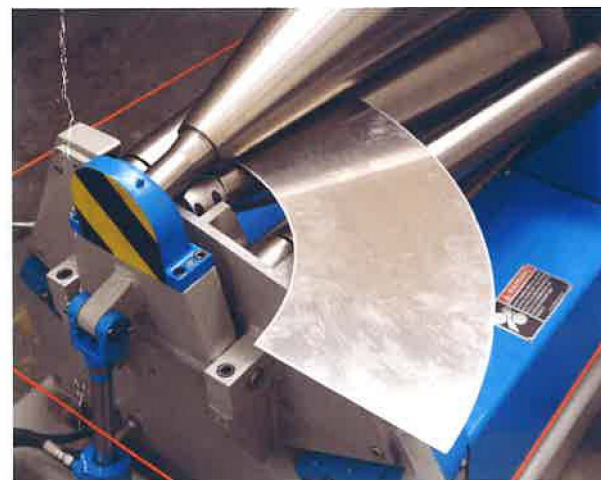

Work piece is entered into the machine & positioned via the calibrated pointer & gage roll.



Near forming roll is raised to form leading edge. Rolls rotate to complete bend.



Near forming roll lowers completely & far forming roll raises to position.

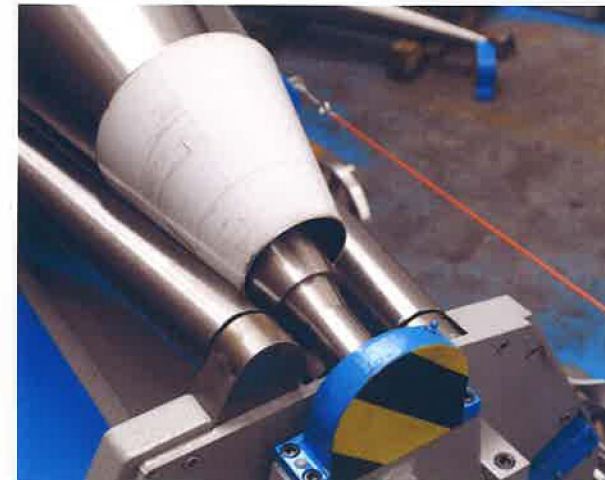

Rolls rotate to complete the forming cycle in 1 pass without any twist or edge deformation from a cone snubber (as with traditional rolls).

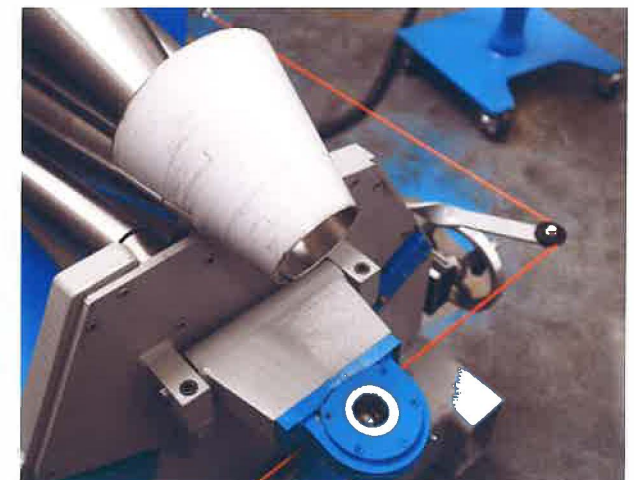

Far forming roll lowers, drop end lowers & finished work piece is removed. Drop end is raised in preparation for next cycle.

## OTHER MACHINES By *Athens*



101-10-8 (1/2" x 8') hydraulic pinch pyramid plate bending machine



B Series

403-7-5 (5/16 x 5') with digital readout and 421-3 control



AR-31 with 423-LP6 control



### MADE IN THE USA

For two generations the family of and Athens has been designing and manufacturing metal forming machines for the industry small and large. We build these machines in a simple setting, exercising serious craftsmanship and integrity. Many of the high quality components are manufactured in our shops in Tennessee, USA or purchased from a domestic or worldwide suppliers. Special attention is paid to quality, availability, and durability.

Your satisfaction and the performance of our machine is held in highest regard. Owners

### PUBLIC NOTICE

Some distributors including those listed, sell Athens machines via the internet. Athens however does not, nor does it have a website or fax. You may reach us by phone, mail, or courier. (We accept courier collect charges for urgent inquiries or drawings).

### ENGINEERING—MANUFACTURING—MAIN OFFICE

**Athens Machine Builders**

**600 Eagle Way**

**Spencer, TN 38585**

**(800) 991-4225**

**www.ahbinc.com • customerservice@ahbinc.com**

**ISO Certified**