

www.clausing-industrial.com



A Full Range of Precision, High Performance Geared-drive and Belt-drive Round-column Drills



Models with Autofeed Reversing Systems for Tapping Standard

DRILLING



Series T Geared-drive Round-column Drills

A heavy-duty Industrial Drilling Machine,
designed for easy operation with manual feed

Standard Features and Equipment:

- Drilling capacity in steel: 1" (25mm) maximum
- Drilling capacity in cast iron: 1.18" (30mm) maximum
- Tapping capacity in steel: .71" (18mm) maximum
- Tapping capacity in cast iron: .87" (22mm) maximum
- Depth scale and adjustable depth stop
- "RS" models are equipped with automatic feed reversing system for tapping
- Thermomagnetic switch
- Spindle reversing switch
- Automatic tool ejector
- Emergency STOP
- High/low speed range selector
- Drill guard with microswitch



Optional **MCC-KT**
13.8" x 10.8 cross
slide table



Controls mounted on the front
of the headstock for operator
convenience for fast and easy
speed selection

Capacities, Specifications and Dimensions

Models Auto feed reversing "RS" Models	TS18	TM18	TL18	TS25 TS25RS	TM25 TM25RS	TL25 TL25RS
Capacities:						
Maximum drilling capacity in steel	.71" (18mm)	.71" (18mm)	.71" (18mm)	1" (25mm)	1" (25mm)	1" (25mm)
Maximum drilling capacity in cast iron	1" (25mm)	1" (25mm)	1" (25mm)	1.18" (30mm)	1.18" (30mm)	1.18" (30mm)
Maximum tapping capacity in steel	.55" (14mm)	.55" (14mm)	.55" (14mm)	.71" (18mm)	.71" (18mm)	.71" (18mm)
Maximum tapping capacity in cast iron	.71" (18mm)	.71" (18mm)	.71" (18mm)	.87" (22mm)	.87" (22mm)	.87" (22mm)
Specifications:						
Spindle taper	3MT	3MT	3MT	3MT	3MT	3MT
Quill diameter	2.44" (62mm)	2.44" (62mm)	2.44" (62mm)	2.44" (62mm)	2.44" (62mm)	2.44" (62mm)
Spindle travel (drilling depth)	4.72" (120mm)	4.72" (120mm)	4.72" (120mm)	4.72" (120mm)	4.72" (120mm)	4.72" (120mm)
Main motor power	.75/1.1 Hp (.55/.80 Kw)			1/1.5 Hp (.73/1.1 Kw)		
No. of speeds (see speed charts)	8	8	8	8	8	8
Dimensions and Weights						
Height (A)	47.6" (1210mm)	48.4" (1230mm)	75.8" (1925mm)	47.6" (1210mm)	48.4" (1230mm)	75.8" (1925mm)
Height (A1)	79.1" (2010mm)	79.9" (2030mm)	-	79.1" (2010mm)	79.9" (2030mm)	-
Base: length x width (B)	22" x 15" (560x380mm)	22" x 15" (560x380mm)	24" x 15" (600x380mm)	22" x 15" (560x380mm)	22" x 15" (560x380mm)	24" x 15" (600x380mm)
Base to spindle (C)	See (E)	20.9" (530mm)	47.6" (1210mm)	See (E)	20.9" (530mm)	47.6" (1210mm)
Spindle center to column (D)	9.84" (250mm)	9.84" (250mm)	9.84" (250mm)	9.84" (250mm)	9.84" (250mm)	9.84" (250mm)
Spindle to Table (E)						
Minimum	4.33" (110mm)	1.18" (30mm)	4.13" (105mm)	4.33" (110mm)	1.18" (30mm)	4.13" (105mm)
Maximum	19.7" (500mm)	12.6" (320mm)	25.2" (640mm)	19.7" (500mm)	12.6" (320mm)	25.2" (640mm)
Worktable: length x width (F)	-	10.6" x 11.8" (270 x 300mm)	-	-	10.6" x 11.8" (270 x 300mm)	-
Base height (G)	3.1" (80mm)	3.1" (80mm)	3.7" (95mm)	3.1" (80mm)	3.1" (80mm)	3.7" (95mm)
Column diameter (H)	3.94" (100mm)	3.94" (100mm)	3.94" (100mm)	3.94" (100mm)	3.94" (100mm)	3.94" (100mm)
Floor to top of base (I)	34.6" (880mm)	34.6" (880mm)	-	34.6" (880mm)	34.6" (880mm)	-
Cabinet height (J)	31.5" (800mm)	31.5" (800mm)	-	31.5" (800mm)	31.5" (800mm)	-
Net weight	298 lbs (135kg)	364 lbs (165kg)	408 lbs (185kg)	298 lbs (135kg)	364 lbs (165kg)	408 lbs (185kg)
Shipping weight	353 lbs (160kg)	419 lbs (190kg)	496 lbs (225kg)	353 lbs (160kg)	419 lbs (190kg)	496 lbs (225kg)
Shipping dimension (length x width x height)	20" x 32" x 55" (.5 x .8 x 1.4m)	20" x 32" x 55" (.5 x .8 x 1.4m)	20" x 36" x 75" (.5 x .9 x 2.1m)	20" x 32" x 55" (.5 x .8 x 1.4m)	20" x 32" x 55" (.5 x .8 x 1.4m)	20" x 36" x 75" (.5 x .9 x 2.1m)

Standard motor: 1800/3600 rpm

Spindle speeds (rpm)

90-192-300-504-612-1020-1740-3360

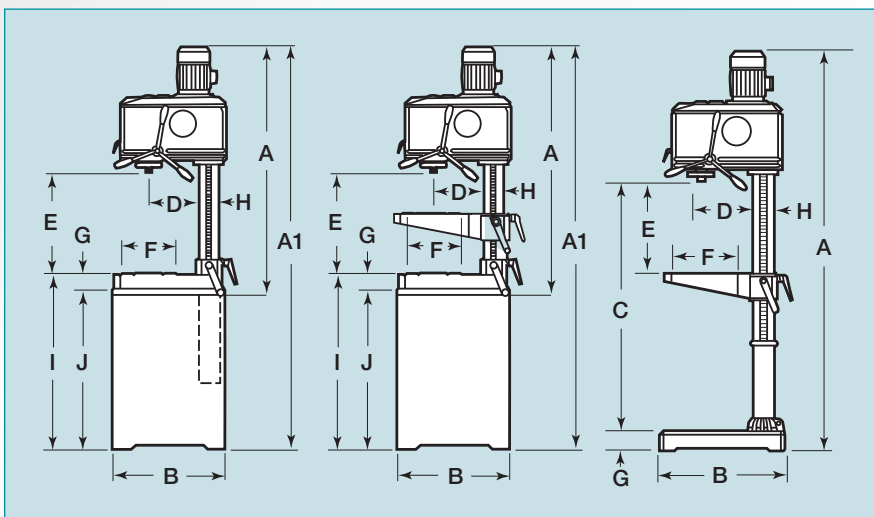

Optional
PKB
cabinets





Series K Belt-drive Round-column Drills

A heavy-duty Industrial Drilling Machine,
designed for easy operation with manual feed

Standard Features and Equipment:

- Drilling capacity in steel: 1" (25mm) maximum
- Drilling capacity in cast iron: 1.18" (30mm) maximum
- Tapping capacity in steel: .71" (18mm) maximum
- Tapping capacity in cast iron: .87" (22mm) maximum
- "RS" models are equipped with automatic feed reversing system for tapping
- "EV" models are equipped with electronic variable speed
- "EVRS" models are equipped with electronic variable speed and automatic feed reversing system for tapping
- Depth scale and adjustable depth stop
- Thermomagnetic switch
- Spindle reversing switch
- Automatic tool ejector
- Emergency STOP
- High/low speed range selector
- Drill guard with microswitch



Optional **MCC-KT**
13.8" x 10.8 cross
slide table



Capacities, Specifications and Dimensions

Step pulley & "EV" Models Auto feed reversing "EVRS" Models	KS18	KM18	KL18	KS25/EV KS25/EV/RS	KM25/EV KM25/EV/RS	KL25/EV KL25/EV/RS
Capacities:						
Maximum drilling capacity in steel	.71" (18mm)	.71" (18mm)	.71" (18mm)	1" (25mm)	1" (25mm)	1" (25mm)
Maximum drilling capacity in cast iron	1" (25mm)	1" (25mm)	1" (25mm)	1.18" (30mm)	1.18" (30mm)	1.18" (30mm)
Maximum tapping capacity in steel	.55" (14mm)	.55" (14mm)	.55" (14mm)	.71" (18mm)	.71" (18mm)	.71" (18mm)
Maximum tapping capacity in cast iron	.71" (18mm)	.71" (18mm)	.71" (18mm)	.87" (22mm)	.87" (22mm)	.87" (22mm)
Specifications:						
Spindle taper	3MT	3MT	3MT	3MT	3MT	3MT
Quill diameter	2.44" (62mm)	2.44" (62mm)	2.44" (62mm)	2.44" (62mm)	2.44" (62mm)	2.44" (62mm)
Spindle travel (drilling depth)	4.72" (120mm)	4.72" (120mm)	4.72" (120mm)	4.72" (120mm)	4.72" (120mm)	4.72" (120mm)
Main motor power	.5/.75 Hp (.40/.55 Kw)			1.5 Hp (1.1 Kw)		
No. of speeds (see speed charts)	10	10	10	10	10	10
Dimensions and Weights						
Height (A)	42.1" (1070mm)	42.9" (1090mm)	-	42.1" (1070mm)	42.9" (1090mm)	-
Height (A1)	73.6" (1870mm)	74.4" (1890mm)	70" (1780mm)	73.6" (1870mm)	74.4" (1890mm)	70" (1780mm)
Base: length x width (B)	22" x 15" (560x380mm)	22" x 15" (560x380mm)	24" x 15" (600x380mm)	22" x 15" (560x380mm)	22" x 15" (560x380mm)	24" x 15" (600x380mm)
Base to spindle (C)	See (E)	20.9" (530mm)	47.6" (1210mm)	See (E)	20.9" (530mm)	47.6" (1210mm)
Spindle center to column (D)	9.84" (250mm)	9.84" (250mm)	9.84" (250mm)	9.84" (250mm)	9.84" (250mm)	9.84" (250mm)
Spindle to Table (E)						
Minimum	4.33" (110mm)	1.18" (30mm)	4.13" (105mm)	4.33" (110mm)	1.18" (30mm)	4.13" (105mm)
Maximum	19.7" (500mm)	12.6" (320mm)	25.2" (640mm)	19.7" (500mm)	12.6" (320mm)	25.2" (640mm)
Worktable: length x width (F)	-	10.6" x 11.8" (270 x 300mm)	-	-	10.6" x 11.8" (270 x 300mm)	-
Base height (G)	3.1" (80mm)	3.1" (80mm)	3.7" (95mm)	3.1" (80mm)	3.1" (80mm)	3.7" (95mm)
Column diameter (H)	3.94" (100mm)	3.94" (100mm)	3.94" (100mm)	3.94" (100mm)	3.94" (100mm)	3.94" (100mm)
Floor to top of base (I)	34.6" (880mm)	34.6" (880mm)	-	34.6" (880mm)	34.6" (880mm)	-
Cabinet height (J)	31.5" (800mm)	31.5" (800mm)	-	31.5" (800mm)	31.5" (800mm)	-
Net weight	276 lbs (125kg)	330 lbs (150kg)	385 lbs (175kg)	276 lbs (125kg)	330 lbs (150kg)	385 lbs (175kg)
Shipping weight	330 lbs (150kg)	375 lbs (170kg)	374 lbs (215kg)	330 lbs (150kg)	375 lbs (170kg)	474 lbs (215kg)
Shipping dimension (length x width x height)	20" x 32" x 55" (.5 x .8 x 1.4m)	20" x 32" x 55" (.5 x .8 x 1.4m)	20" x 36" x 75" (.5 x .9 x 2.1m)	20" x 32" x 55" (.5 x .8 x 1.4m)	20" x 32" x 55" (.5 x .8 x 1.4m)	20" x 36" x 75" (.5 x .9 x 2.1m)

Standard motor: 1800/3600 rpm

Step pulley spindle speeds (rpm)

240-432-480-780-864-1404-1560-2400-2808-4800

Variable speed spindle speed range (rpm)

300-4800

Note: K25EV/RS models take a 1 speed motor of 1.5 Hp (1.1 Kw) and variable speed range 300-4800.

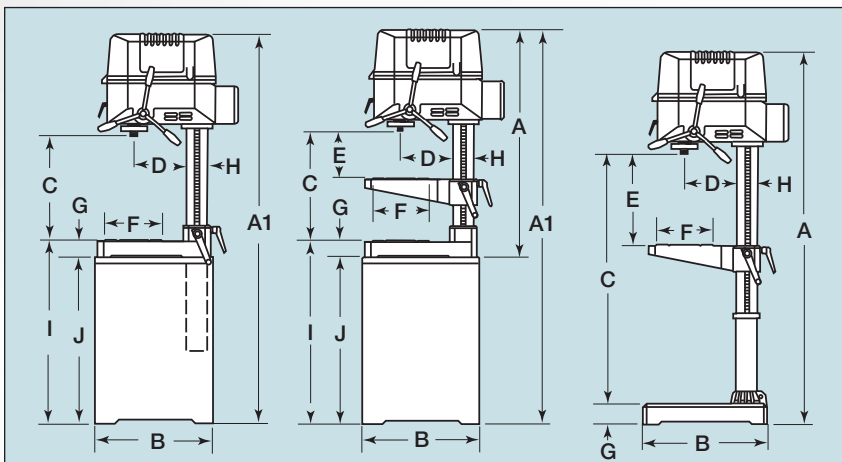

Optional
PKB
cabinets.





Series Z Belt-drive Round-column Drills

With Manual or Mechanical Clutch

Select the Z series step pulley or variable speed belt-drive Industrial Drilling Machine that is right for the job. The SZ-32 model is equipped with manual feed and step pulley drive, the AZ-32V model is equipped with a mechanical clutch and mechanical variable speed drive.

Standard Features and Equipment:

- Drilling capacity in steel: up to 1.26" (32mm) maximum
- Drilling capacity in cast iron: up to 1.38" (35mm) maximum
- Tapping capacity in steel: up to .87" (30mm) maximum
- Tapping capacity in cast iron: up to 1.18" (30mm) maximum
- Automatic feed reversing system for tapping on "RS" models
- Machine base with 2 T-slots, coolant tank and pump
- Large worktable with 3 T-slots,
- Feed crank wheel for manual feed
- Depth scale and adjustable depth stop
- Automatic tool ejector
- Spindle reversing switch
- Work Light
- Built-in low voltage electrical equipment in machine head
- Emergency STOP
- Drill guard with microswitch



*Optional **MCC-ZX**
15" x 8.7" cross
slide table for
model Z32*



*Optional **MG** rotating
table with 3 T-slots
for model Z32*



SZ-32

Capacities, Specifications and Dimensions

Standard Models Auto feed reversing "RS" Models	SZ32	AZ32V AZ32VRS
Capacities:		
Maximum drilling capacity in steel	1.26" (32mm)	1.26" (32mm)
Maximum drilling capacity in cast iron	1.38" (35mm)	1.38" (35mm)
Maximum tapping capacity in steel	.87" (22mm)	.87" (22mm)
Maximum tapping capacity in cast iron	1.18" (30mm)	1.18" (30mm)
Specifications:		
Spindle taper	3MT	3MT
Quill diameter	2.56" (65mm)	2.56" (65mm)
Spindle travel (drilling depth)	5.91" (150mm)	5.91" (150mm)
Main motor power	1.2/1.8 Hp (.9/1.3Kw)	1.2/1.8 Hp (.9/1.3Kw)
Coolant pump motor power	.1 Hp (.07Kw)	.1 Hp (.07Kw)
Number of speeds	10	Infinitely Variable
Number of automatic feeds	-	2
Auto feed range: in./rev. (mm/rev)	-	.0039/.0079 (0.1-0.2)
Dimensions and Weights		
Height (A)	76.8" (1950mm)	76.8" (1950mm)
Base: Length x Width (B)	26.8" x 16.5" (680 x 420mm)	26.8" x 16.5" (680 x 420mm)
Base to spindle (C)	50.59" (1285mm)	50.59" (1285mm)
Spindle center to column (D)	11.81" (300mm)	11.81" (300mm)
Spindle to Table (E)		
Minimum	6.7" (170mm)	6.7" (170mm)
Maximum	32.87" (835mm)	32.87" (835mm)
Worktable: Length x Width (F)	15.75" x 18.9" (400 x 480mm)	15.75" x 18.9" (400 x 480mm)
Base height (G)	4.72" (120mm)	4.72" (120mm)
Column diameter (H)	4.92" (125mm)	4.92" (125mm)
Net weight	573 lbs (260Kg)	639 lbs (290Kg)
Shipping weight	683 lbs (310Kg)	750 lbs (340Kg)
Shipping dimension (L x W x H)	24" x 44" x 91" (.6x1.1x2.3m)	24" x 44" x 91" (.6x1.1x2.3m)

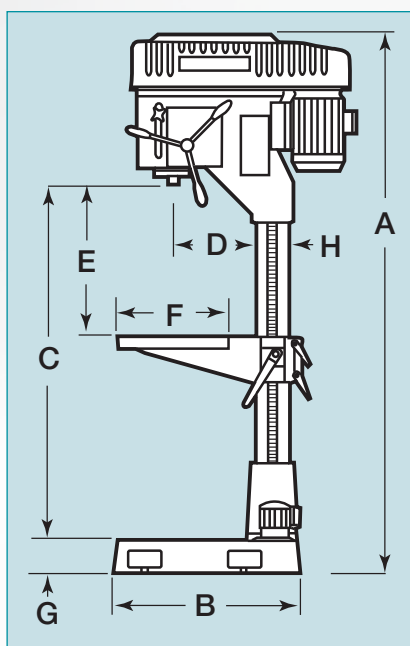

Standard motor: 2 Speed 900/1800 rpm

Model	Spindle speeds (rpm)
SZ32	900rpm: 170-265-415-650-1035 1800rpm: 340-530-830-1300-2070
AZ32V	Infinitely Variable: 96-1405 rpm

"RS" models are equipped with automatic feed reversing system for tapping.

Standard Fixed Table Models

Model	Description (Dimension see page 21)
1SZ32	23.6" (600mm) drill with Fixed Table
1AZ32V	23.6" (600mm) drill with Fixed Table
1AZ32VRS	23.6" (600mm) drill with Fixed Table and Tapping System



SZ-32 model is equipped with manual feed and step pulley drive



AZ-32V model is equipped with a mechanical clutch and mechanical variable speed drive



Series Z Belt-drive Round-column Drills

*With Manual, Mechanical Clutch or
Electromagnetic Clutch Feed Control*

Select the Z series electronic variable speed belt-drive Industrial Drilling Machine that is right for the job. SZ models are equipped with manual feed, AZ models are equipped with a mechanical clutch automatic feed control and the BZ models are equipped with electromagnetic automatic feed control.

Standard Features and Equipment:

- Drilling capacity in steel: up to 1.57" (40mm) maximum
- Drilling capacity in cast iron: up to 1.77" (45mm) maximum
- Tapping capacity in steel: up to 1.30" (33mm) maximum
- Tapping capacity in cast iron: up to 1.54" (39mm) maximum
- Automatic feed reversing system for tapping
- Digital rpm counter
- Machine base with 2 T-slots, coolant tank and pump
- Large rotating worktable with 3 T-slots,
- Feed crank wheel for manual feed
- Depth scale and adjustable depth stop
- Automatic tool ejector
- Spindle reversing switch
- Work Light
- Built-in low voltage electrical equipment in machine head
- Emergency STOP
- Drill guard with microswitch



*Optional **MCC-ZX**
15" x 8.7" cross
slide table For
model Z34*



*Optional **MGM**
rotating table with
3 T-slots on one
side and a vise on
the other for model Z34*



AZ-40

Capacities, Specifications and Dimensions

Standard Models	SZ/AZ/BZ34	SZ/AZ/BZ40
Capacities:		
Maximum drilling capacity in steel	1.34" (34mm)	1.57" (40mm)
Maximum drilling capacity in cast iron	1.57" (40mm)	1.77" (45mm)
Maximum tapping capacity in steel	1.06" (27mm)	1.30" (33mm)
Maximum tapping capacity in cast iron	1.30" (33mm)	1.54" (39mm)
Specifications:		
Spindle taper	3MT	3MT
Quill diameter	2.95" (75mm)	2.95" (75mm)
Spindle travel (drilling depth)	5.9" (150mm)	7.09" (180mm)
Main motor power	3 Hp (2.2Kw)	4 Hp (3Kw)
Coolant pump motor power	.1 Hp (.07Kw)	.1 Hp (.07Kw)
Spindle speeds (electronic variable speed)	100-2000 rpm	100-2000 rpm
Number of automatic feeds	3	3
Auto feed range: in./rev. (mm/rev)	.0039/.0079/.0118 (0.1-0.2-0.3)	.0039/.0079/.0118 (0.1-0.2-0.3)
Dimensions and Weights		
Height (A)	76.5" (1945mm)	76.8" (1950mm)
Base: Length x Width (B)	29.1" x 16.2" (740 x 412mm)	31.5" x 18.8" (800 x 476mm)
Base to spindle (C)	48.4" (1230mm)	48.4" (1230mm)
Spindle center to column (D)	11.81" (300mm)	13.78" (350mm)
Spindle to Table (E)		
Minimum	1.97" (50mm)	1.97" (50mm)
Maximum	28.5" (725mm)	27.2" (690mm)
Worktable: Length x Width (F)	15.75" x 18.9" (400 x 480mm)	18.9" x 22.05" (480 x 560mm)
Base height (G)	4.72" (120mm)	4.72" (120mm)
Column diameter (H)	4.92" (125mm)	5.91" (150mm)
Net weight	794 lbs (360Kg)	1,014 lbs (460Kg)
Shipping weight	904 lbs (410Kg)	1,124 lbs (510Kg)
Shipping dimension (L x W x H)	92" x 24" x 42" (2.34x.61x1.06m)	92" x 24" x 42" (2.34x.61x1.06m)

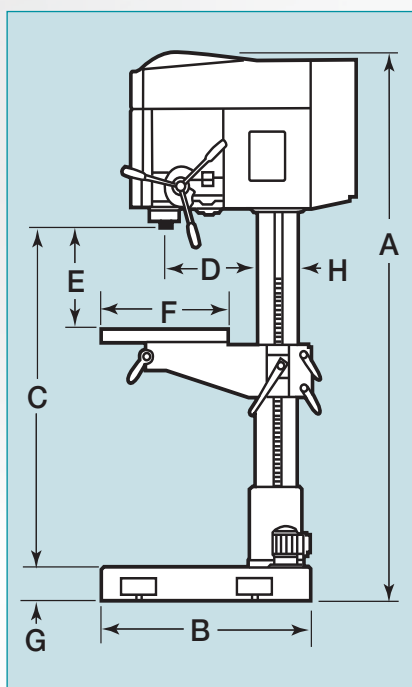

Standard motor: 1800 rpm

Model	Spindle speeds (rpm)
AZ34	Electronic Variable: 100-2000 rpm
AZ40	Electronic Variable: 100-2000 rpm

Optional spindle motors

Motor	Speed range
1800-3600 rpm	340-4140 rpm

Standard Fixed Table Models

Model	Description (Dimension see page 21)
1SZ-34	23.6" (600mm) drill with Fixed Table and Tapping System
1AZ-34	23.6" (600mm) drill with Fixed Table and Tapping System
1BZ-34	23.6" (600mm) drill with Fixed Table and Tapping System
1SZ-40	23.6" (600mm) drill with Fixed Table and Tapping System
1AZ-40	23.6" (600mm) drill with Fixed Table and Tapping System
1BZ-40	23.6" (600mm) drill with Fixed Table and Tapping System

"RS" models are equipped with automatic feed reversing system for tapping.



The A/BZ34/40 are equipped with a 3 feed rate, Mechanical Clutch Automatic Feed Control, the feed rate is easily selected by the Feed Selector



All Z34/40 are equipped with an Electronic Variable Speed Drive with a Digital Display on front of the headstock



Series X Gear-drive Round-column Drills

With Manual or Mechanical Clutch

The X series range of easy to operate Industrial Drilling Machines offer a variety of capacities and feeds. Engineered for a long work life the X series drills are a great value. SX models are equipped with manual feed, AX models are equipped with a mechanical clutch automatic feed control.

Standard Features and Equipment:

- Drilling capacity in steel: up to 1.26" (32mm) maximum
- Drilling capacity in cast iron: up to 1.38" (35mm) maximum
- Tapping capacity in steel: up to .87" (22mm) maximum
- Tapping capacity in cast iron: up to 1.18" (30mm) maximum
- Automatic feed reversing system for tapping on "RS" models
- Hardened and ground high quality steel gears
- Speed plate and selecting levers on front of head
- Gear box lubrication by automatic pump
- Machine base with 2 T-slots, coolant tank and pump
- Large worktable with 3 T-slots
- Feed crank wheel for manual feed
- Depth scale and adjustable depth stop
- Automatic tool ejector
- Work Light
- Built-in low voltage electrical equipment in machine head
- Emergency STOP
- Drill guard with microswitch

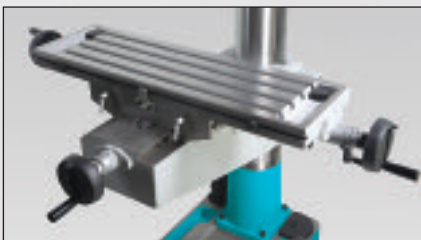

*Optional MCC-ZX
15" x 8.7" cross
slide table for
model X32*



*Optional MG
rotating table
with 3 T-slots for
model X32*



AX32

*Head mounted speed controls for
easy spindle speed setting*

Capacities, Specifications and Dimensions

Standard Models Auto feed reversing "RS" Models	SX32 SX32RS	AX32 AX32RS
Capacities:		
Maximum drilling capacity in steel	1.26" (32mm)	1.26" (32mm)
Maximum drilling capacity in cast iron	1.38" (35mm)	1.38" (35mm)
Maximum tapping capacity in steel	.87" (22mm)	.87" (22mm)
Maximum tapping capacity in cast iron	1.18" (30mm)	1.18" (30mm)
Specifications:		
Spindle taper	3MT	3MT
Quill diameter	2.56" (65mm)	2.56" (65mm)
Spindle travel (drilling depth)	5.91" (150mm)	5.91" (150mm)
Main motor power	1.5 Hp (1.1Kw)	1.5 Hp (1.1Kw)
Coolant pump motor power	.1 Hp (.07Kw)	.1 Hp (.07Kw)
Number of speeds	9	9
Number of automatic feeds	-	2
Auto feed range: in./rev. (mm/rev)	-	.0039/.0079 (0.1-0.2)
Dimensions and Weights		
Height (A)	87.4" (2220mm)	87.4" (2220mm)
Base: Length x Width (B)	26.8" x 16.5" (680 x 420mm)	26.8" x 16.5" (680 x 420mm)
Base to spindle (C)	50.39" (1280mm)	50.39" (1280mm)
Spindle center to column (D)	11.81" (300mm)	11.81" (300mm)
Spindle to Table (E)		
Minimum	5.71" (145mm)	5.71" (145mm)
Maximum	31.89" (810mm)	31.89" (810mm)
Worktable: Length x Width (F)	15.75" x 18.9" (400 x 480mm)	15.75" x 18.9" (400 x 480mm)
Base height (G)	4.72" (120mm)	4.72" (120mm)
Column diameter (H)	4.92" (125mm)	4.92" (125mm)
Net weight	694 lbs (315Kg)	728 lbs (330Kg)
Shipping weight	794 lbs (360Kg)	827 lbs (375Kg)
Shipping dimension (L x W x H)	24" x 44" x 91" (.6x1.1x2.3m)	24" x 44" x 91" (.6x1.1x2.3m)

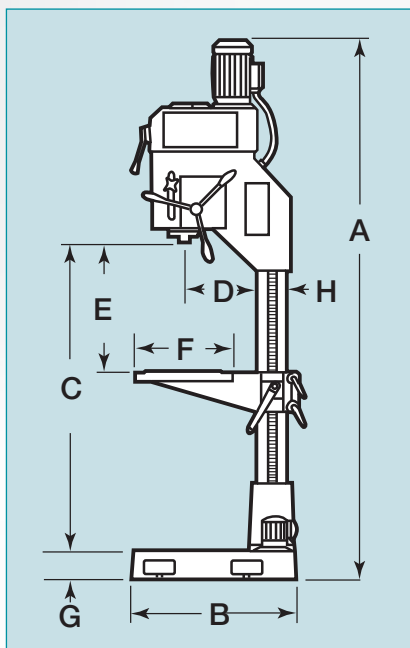

Standard motor: 1800 rpm

Spindle speeds SX32, AX32

123-180-257-295-432-617-820-1200-1714 rpm

Optional spindle motors

Motor	Speed range
1200 rpm	63-1000 rpm
3600 rpm	250-3480 rpm
900/1800 rpm	63-1000 rpm
1800-3600 rpm	123-3428 rpm

Standard Fixed Table Models

Model	Description (Dimension see page 21)
1SX32	23.6" (600mm) drill with Fixed Table
1SX32RS	23.6" (600mm) drill with Fixed Table and Tapping System
1AX32	23.6" (600mm) drill with Fixed Table
1AX32RS	23.6" (600mm) drill with Fixed Table and Tapping System

"RS" models are equipped with automatic feed reversing system for tapping.



Series X Gear-drive Round-column Drills

*With Manual, Mechanical Clutch or
Electromagnetic Clutch Feed Control*

The X series range of easy to operate Industrial Drilling Machines offer a variety of capacities and feeds. Engineered for a long work life the X series drills are a great value. SX models are equipped with manual feed, AX models are equipped with a mechanical clutch automatic feed control and the BX models are equipped with electromagnetic automatic feed control.

Standard Features and Equipment:

- Drilling capacity in steel: up to 1.57" (40mm) maximum
- Drilling capacity in cast iron: up to 1.77" (45mm) maximum
- Tapping capacity in steel: up to 1.30" (33mm) maximum
- Tapping capacity in cast iron: up to 1.54" (39mm) maximum
- Automatic feed reversing system for tapping on "RS" models
- Hardened and ground high quality steel gears
- Speed plate and selecting levers on front of head
- Gear box lubrication by automatic pump
- Machine base with 2 T-slots, coolant tank and pump
- Large rotating worktable with 3 T-slots
- Feed crank wheel for manual feed
- Depth scale and adjustable depth stop
- Automatic tool ejector • Work Light
- Built-in low voltage electrical equipment in machine head
- Emergency STOP • Drill guard with microswitch



*Optional 15" x 8.7"
cross slide table
MCC-ZX X34
MCC-X40 X40*



*Optional MGM
rotating table with
3 T-slots on one side
and a vise on the
other for model X34*



BX40

Capacities, Specifications and Dimensions

Standard Models Auto feed reversing "RS" Models	SX/AX/BX34 SX/AX/BX34RS	SX/AX/BX40 SX/AX/BX40RS
Capacities:		
Maximum drilling capacity in steel	1.34" (34mm)	1.57" (40mm)
Maximum drilling capacity in cast iron	1.57" (40mm)	1.77" (45mm)
Maximum tapping capacity in steel	1.06" (27mm)	1.30" (33mm)
Maximum tapping capacity in cast iron	1.30" (33mm)	1.54" (39mm)
Specifications:		
Spindle taper	4MT	4MT
Quill diameter	2.95" (75mm)	2.95" (75mm)
Spindle travel (drilling depth)	5.9" (150mm)	7.09" (180mm)
Main motor power	2 Hp (1.5Kw)	3 Hp (2.2Kw)
Coolant pump motor power	.1 Hp (.07Kw)	.1 Hp (.07Kw)
Number speeds	9	9
Number of automatic feeds	3	3
Auto feed range: in./rev. (mm/rev)	.0039/.0079/.0118 (0.1-0.2-0.3)	.0039/.0079/.0118 (0.1-0.2-0.3)
Dimensions and Weights		
Height (A)	86.4" (2195mm)	90" (2285mm)
Base: Length x Width (B)	29.1" x 16.2" (740 x 412mm)	31.5" x 18.8" (800 x 476mm)
Base to spindle (C)	48.4" (1230mm)	48.4" (1230mm)
Spindle center to column (D)	11.81" (300mm)	13.78" (350mm)
Spindle to Table (E)		
Minimum	1.97" (50mm)	1.97" (50mm)
Maximum	28.5" (725mm)	27.2" (690mm)
Worktable: Length x Width (F)	15.75" x 18.9" (400 x 480mm)	18.9" x 22.05" (480 x 560mm)
Base height (G)	4.72" (120mm)	4.72" (120mm)
Column diameter (H)	4.92" (125mm)	5.91" (150mm)
Net weight	882 lbs (400Kg)	1,081 lbs (490Kg)
Shipping weight	450 lbs (992Kg)	1,190 lbs (540Kg)
Shipping dimension (L x W x H)	92" x 24" x 42" (2.34x.61x1.06m)	92" x 24" x 42" (2.34x.61x1.06m)

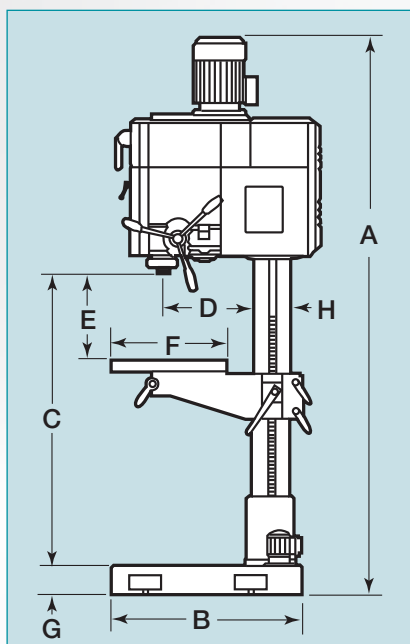

Standard motor: 1800 rpm

Spindle speeds Models SX/AXBX-34 & SX/AXBX-40

158-233-332-383-559-799-1060-1555-2222 rpm

Standard Fixed Table Models

Model	Description (Dimension see page 21)
1SX-34	23.6" (600mm) drill with Fixed Table
1AX-34	23.6" (600mm) drill with Fixed Table
1BX-34	23.6" (600mm) drill with Fixed Table
1SX-40	27.5" (700mm) drill with Fixed Table
1AX-40	27.5" (700mm) drill with Fixed Table
1BX-40	27.5" (700mm) drill with Fixed Table



The A/BX34/40 are equipped with a 3 feed rate, Mechanical Clutch Automatic Feed Control, the feed rate is easily selected by the Feed Selector

"RS" models are equipped with automatic feed reversing system for tapping.

All X34/40, Speed Selector Levers are mounted on the front of the headstock for operator convenience and fast and easy speed selection





Series A Geared-drive Round-column Drills

With Mechanical Clutch Automatic Feed Control

The A series of Industrial Drilling Machines are capable of handling heavier workpieces with a wide range of drilling and tapping capacities. Designed for easy operation with a mechanical clutch for precise automatic feed control that can be activated from the feed crank handle or by the lever on the front of machine head.

Standard Features and Equipment:

- Drilling capacity in steel: up to 1.97" (50mm) maximum
- Drilling capacity in cast iron: up to 2.36" (60mm) maximum
- Tapping capacity in steel: up to 1.42" (36mm) maximum
- Tapping capacity in cast iron: up to 1.65" (42mm) maximum
- Automatic feed reversing system for tapping on "RS" models
- Automatic feed and cut-off by mechanical clutch
- Hardened and ground high quality steel gears
- Speed plate and selecting levers on front of head
- Gear box lubrication by automatic pump
- Machine base with 2 T-slots, coolant tank and pump
- Large rotating table with 3 T-slots
- Feed crank wheel for manual feed
- Front hand wheel for fine feed work
- Depth scale and adjustable depth stop
- Automatic tool ejector
- Work Light
- Built-in low voltage electrical equipment in machine head
- Emergency STOP
- Drill guard with microswitch

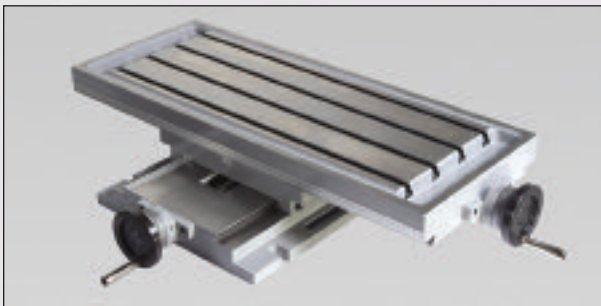

Optional **MB-5D** 18.5" x 11.5" cross slide table



A50

Built-in low voltage electrics, automatic tool ejection system lever and Speed Selector Levers are mounted on the front of the headstock for operator convenience for fast and easy speed selection

Capacities, Specifications and Dimensions

Standard Models Auto feed reversing "RS" Models	A35 A35RS	A40 A40RS	A45 A45RS	A50 A50RS
Capacities:				
Maximum drilling capacity in steel	1.38" (35mm)	1.57" (40mm)	1.77" (45mm)	1.97" (50mm)
Maximum drilling capacity in cast iron	1.77" (45mm)	2.17" (50mm)	2.17" (55mm)	2.36" (60mm)
Maximum tapping capacity in steel	1" (27mm)	1.3" (33mm)	1.3" (33mm)	1.42" (36mm)
Maximum tapping capacity in cast iron	1.3" (33mm)	1.57" (40mm)	1.57" (40mm)	1.65" (42mm)
Specifications:				
Spindle taper	4MT	4MT	4MT	4MT
Quill diameter	2.95" (75mm)	3.46" (88mm)	3.46" (88mm)	3.46" (88mm)
Spindle travel (drilling depth)	7.87" (200mm)	7.87" (200mm)	7.87" (200mm)	9.06" (230mm)
Main motor power	2 Hp (1.5Kw)	3 Hp (2.2Kw)	3 Hp (2.2Kw)	4 Hp (3Kw)
Coolant pump motor power	.1 Hp (.07Kw)	.1 Hp (.07Kw)	.1 Hp (.07Kw)	.1 Hp (.07Kw)
Number of speeds	9	9	9	9
Number of automatic feeds	3	4	4	4
Auto feed range: in./rev. (mm/rev)	.0039/.0079/.0118 (0.1-0.2-0.3)		.0039/.0079/.0118/.0157 (0.1-0.2-0.3-0.4)	
Dimensions and Weights				
Height (A)	81.2" (2265mm)	92.4" (2390mm)	92.4" (2390mm)	97.4" (2475mm)
Base: Length x Width (B)	31.5" x 18.5" (800x470mm)	31.9" x 21.3" (810x540mm)	31.9" x 21.3" (810x540mm)	33.9" x 21.7" (860x550mm)
Base to spindle (C)	47.24" (1200mm)	49.61" (1260mm)	49.61" (1260mm)	51.18" (1300mm)
Spindle center to column (D)	14.57" (370mm)	15.16" (385mm)	15.16" (385mm)	14.57" (370mm)
Spindle to Table (E)				
Minimum	4.72" (120mm)	5.51" (140mm)	5.12" (130mm)	5.91" (150mm)
Maximum	30.71" (780mm)	30.71" (780mm)	30.31" (770mm)	30.31" (770mm)
Worktable: Length x Width (F)	18.9" x 22.1" (480x560mm)	18.9" x 22.1" (480x560mm)	20.5" x 24.4" (520x620mm)	20.5" x 24.4" (520x620mm)
Base height (G)	4.72" (120mm)	5.31" (135mm)	5.31" (135mm)	5.71" (145mm)
Column diameter (H)	6.3" (160mm)	7.09" (180mm)	7.09" (180mm)	7.87" (200mm)
Net weight	1,080 lbs (490mm)	1,345 lbs (610mm)	1,411 lbs (640mm)	1,565 lbs (710mm)
Shipping weight	1,257 lbs (570mm)	1,532 lbs (695mm)	1,598 lbs (725mm)	1,725 lbs (795mm)
Shipping dimension (Length x Width x Height)	28" x 40" x 95" (.7x1x2.4m)	28" x 48" x 103" (.7x1.2x2.6m)	28" x 48" x 103" (.7x1.2x2.6m)	28" x 48" x 103" (.7x1.2x2.6m)

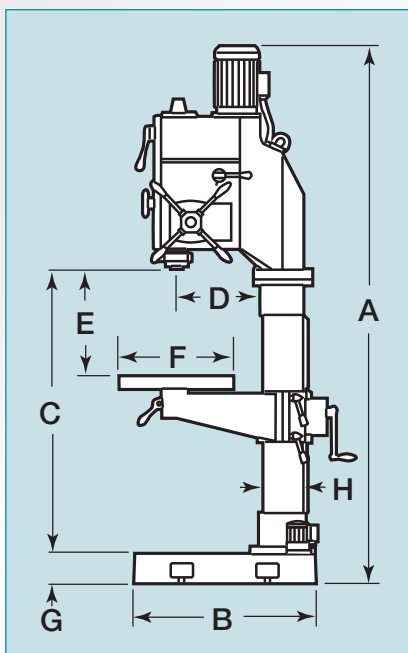

Standard motor: 1800 rpm

Model	Spindle speeds (rpm)
A35	95-135-190-267-380-534-750-1065-1500
A40/45	73-103-149-232-325-472-695-976-1415
A50	66-91-133-206-288-418-617-856-1255

Standard Fixed Table Models

Model	Description (Dimension see page 21)
1A35	29.1" (740mm) with Fixed Table
1A35RS	29.1" (740mm) with Fixed Table and Tapping
1A40	29.5" (750mm) with Fixed Table
1A40RS	29.5" (750mm) with Fixed Table and Tapping
1A45	29.1" (740mm) with Fixed Table
1A45RS	29.1" (740mm) with Fixed Table and Tapping
1A50	29.1" (740mm) with Fixed Table
1A50RS	29.1" (740mm) with Fixed Table and Tapping

Optional spindle motors

Model	Motor	Speed range
A35	1200 rpm	63-1000 rpm
A35	3600 rpm	190-3000 rpm
A35	900/1800 rpm	47-1500 rpm
A35	1800-3600 rpm	95-3000 rpm
A40/45	1200 rpm	50-948 rpm
A40/45	3600 rpm	146-2830 rpm
A40/45	900/1800 rpm	36-1415 rpm
A40/45	1800-3600 rpm	73-2830 rpm
A50	1200 rpm	46-878 rpm
A50	3600 rpm	132-2510 rpm
A50	900/1800 rpm	33-1255 rpm
A50	1800-3600 rpm	66-2510 rpm

"RS" models are equipped with automatic feed reversing system for tapping.



Series B Geared-drive Round-column Drills

With Push-button Electromagnetic Clutch Automatic Feed Control

The B series is a rugged built Industrial Drilling Machine designed to handle large workpieces and offers the widest range of large capacity drilling and tapping. The B series is equipped with an electromagnetic clutch for precise automatic feed control that can be activated from any of the 4 white push-buttons built into the end of the feed crank handles.

Standard Features and Equipment:

- Drilling capacity in steel: 2.75" (70mm) maximum
- Drilling capacity in cast iron: 3.15" (80mm) maximum
- Tapping capacity in steel: 2" (50mm) maximum
- Tapping capacity in cast iron: 2.36" (60mm) maximum
- Automatic feed reversing system for tapping on "RS" models
- Automatic feed and cut-off by electromagnetic clutch
- Hardened and ground high quality steel gears
- Speed plate and selecting levers on front of head
- Gear box lubrication by automatic pump
- Machine base with 2 T-slots, coolant tank and pump
- Large rotating table with 3 T-slots
- Feed crank wheel for manual feed
- Front hand wheel for fine feed work
- Depth scale and adjustable depth stop
- Automatic tool ejector
- Work Light
- Built-in low voltage electrical equipment in machine head
- Emergency STOP
- Drill guard with microswitch



Optional **MB-5D** 18.5" x 11.5" cross slide table



Built-in low voltage electrics, automatic tool ejection system lever and Speed Selector Levers are mounted on the front of the headstock for operator convenience for fast and easy speed selection

Capacities, Specifications and Dimensions

Standard Models Auto feed reversing "RS" Models	B35 B35RS	B40 B40RS	B45 B45RS	B50 B50RS	B60 B60RS	B70 B70RS
Capacities:						
Maximum drilling capacity in steel	1.38" (35mm)	1.57" (40mm)	1.77" (45mm)	1.97" (50mm)	2.36" (60mm)	2.75" (70mm)
Maximum drilling capacity in cast iron	1.77" (45mm)	2.17" (50mm)	2.17" (55mm)	2.36" (60mm)	2.75" (70mm)	3.15" (80mm)
Maximum tapping capacity in steel	1" (27mm)	1.3" (33mm)	1.3" (33mm)	1.42" (36mm)	1.65" (42mm)	2" (50mm)
Maximum tapping capacity in cast iron	1.3" (33mm)	1.57" (40mm)	1.57" (40mm)	1.65" (42mm)	2" (50mm)	2.36" (60mm)
Specifications:						
Spindle taper	4MT	4MT	4MT	4MT	5MT	5MT
Quill diameter	2.95" (75mm)	3.46" (88mm)	3.46" (88mm)	3.46" (88mm)	3.54" (90mm)	3.54" (90mm)
Spindle travel (drilling depth)	7.87" (200mm)	7.87" (200mm)	7.87" (200mm)	9.06" (230mm)	10.24" (260mm)	10.24" (260mm)
Main motor power	2 Hp (1.5Kw)	3 Hp (2.2Kw)	3 Hp (2.2Kw)	4 Hp (3Kw)	5.5 Hp (4Kw)	7.5 Hp (5.5Kw)
Coolant pump motor power	.1 Hp (.07Kw)	.1 Hp (.07Kw)	.1 Hp (.07Kw)	.1 Hp (.07Kw)	.12 Hp (.08Kw)	.12 Hp (.08Kw)
Number of speeds (see speed charts)	9	9	9	9	12	12
Number of automatic feeds	3	4	4	6	6	6
Auto feed range: in./rev. (mm/rev)	.0039/.0079/.0118 (0.1-0.2-0.3)	.0039/.0079/.0118/.0157 (0.1-0.2-0.3-0.4)	.0039/.0079/.0118/.0157 (0.1-0.2-0.3-0.4)	.0039/.0079/.0118/.0157/.0197/.0236 (0.1-0.2-0.3-0.4-0.5-0.6)	.0039/.0079/.0118/.0157/.0197/.0236 (0.1-0.2-0.3-0.4-0.5-0.6)	.0039/.0079/.0118/.0157/.0197/.0236 (0.1-0.2-0.3-0.4-0.5-0.6)
Dimensions and Weights						
Height (A)	81.2" (2285mm)	92.4" (2390mm)	92.4" (2390mm)	97.4" (2475mm)	103.9" (2640mm)	103.9" (2640mm)
Base: Length x Width (B)	31.5" x 18.5" (800x470mm)	31.9" x 21.3" (810x560mm)	31.9" x 21.3" (810x560mm)	33.9" x 21.7" (860x550mm)	35.8" x 23.2" (910x590mm)	35.8" x 23.2" (910x590mm)
Base to spindle (C)	47.24" (1200mm)	49.61" (1280mm)	49.61" (1280mm)	51.18" (1300mm)	49.21" (1250mm)	49.21" (1250mm)
Spindle center to column (D)	14.57" (370mm)	15.16" (385mm)	15.16" (385mm)	14.57" (370mm)	15.75" (400mm)	15.75" (400mm)
Spindle to Table (E)						
Minimum	4.72" (120mm)	5.51" (140mm)	5.12" (130mm)	5.91" (150mm)	3.15" (80mm)	3.15" (80mm)
Maximum	30.71" (780mm)	30.71" (780mm)	30.31" (770mm)	30.71" (770mm)	25.98" (660mm)	25.98"
Worktable: Length x Width (F)	18.9" x 22.1" (480x560mm)	18.9" x 22.1" (480x560mm)	20.5" x 24.4" (520x620mm)	20.5" x 24.4" (520x620mm)	23.6" x 27.6" (600x700mm)	23.6" x 27.6" (600x700mm)
Base height (G)	4.72" (120mm)	5.31" (135mm)	5.31" (135mm)	5.71" (145mm)	6.3" (160mm)	6.3" (160mm)
Column diameter (H)	6.3" (160mm)	7.09" (180mm)	7.09" (180mm)	7.87" (200mm)	8.66" (220mm)	8.66" (220mm)
Net weight	1,080 lbs (490Kg)	1,345 lbs (610Kg)	1,411 lbs (640Kg)	1,587 lbs (720Kg)	1,808 lbs (820Kg)	1,852 lbs (840Kg)
Shipping weight	1,257 lbs (570Kg)	1,532 lbs (695Kg)	1,598 lbs (725Kg)	1,725 lbs (805Kg)	2,025 lbs (920Kg)	2,072 lbs (940Kg)
Shipping dimension (Length x Width x Height)	28" x 40" x 95" (.7 x .1 x 2.4m)	28" x 40" x 103" (.7 x .1.2 x 2.6m)	28" x 40" x 103" (.7 x .1.2 x 2.6m)	28" x 40" x 103" (.7 x .1.2 x 2.6m)	32" x 52" x 111" (.8 x .1.3 x 2.8m)	32" x 52" x 111" (.8 x .1.3 x 2.8m)

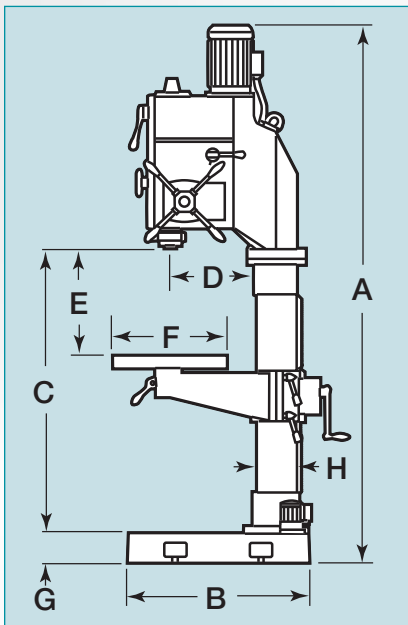

Standard motor: 1800 rpm

Model	Spindle speeds (rpm)
B35	95-135-190-267-380-534-750-1065-1500
B40/45	73-103-149-232-325-472-695-976-1415
B50	66-91-133-206-288-418-617-866-1255
B60	76-96-127-165-238-296-392-513-670-838-1107-1446
B70	62-81-104-133-191-250-321-410-532-683-878-1120

Standard Fixed Table Models

Model	Description (Dimension see page 21)
1B35	29.1" (740mm) with Fixed Table
1B35RS	29.1" (740mm) with Fixed Table and Tapping
1B40	29.5" (750mm) with Fixed Table
1B40RS	29.5" (750mm) with Fixed Table and Tapping
1B45	29.5" (750mm) with Fixed Table
1B45RS	29.5" (750mm) with Fixed Table and Tapping
1B50	29.1" (740mm) with Fixed Table
1B50RS	29.1" (740mm) with Fixed Table and Tapping

"RS" models are equipped with automatic feed reversing system for tapping.

Optional spindle motors

Model	Motor	Speed range
B35	1200 rpm	63-1000 rpm
B35	3600 rpm	190-3000 rpm
B35	900/1800 rpm	47-1500 rpm
B35	1800-3600 rpm	95-3000 rpm
B40/45	1200 rpm	50-948 rpm
B40/45	3600 rpm	146-2830 rpm
B40/45	900/1800 rpm	36-1415 rpm
B40/45	1800-3600 rpm	73-2830 rpm
B50	1200 rpm	46-878 rpm
B50	3600 rpm	132-2510 rpm
B50	900/1800 rpm	33-1255 rpm
B50	1800-3600 rpm	66-2510 rpm
B60	1200 rpm	54-1012 rpm
B60	3600 rpm	152-2892 rpm
B60	900/1800 rpm	38-1446 rpm
B60	1800-3600 rpm	76-2892 rpm
B70	1200 rpm	40-748 rpm
B70	3600 rpm	124-2440 rpm
B70	900/1800 rpm	31-1120 rpm
B70	1800/3600 rpm	62-2240 rpm



Series C Belt/Geared-drive Round-column Drills

With Push-button Electromagnetic Clutch Automatic Feed Control

The C-series of Industrial Drilling Machines are capable of handling heavier workpieces with a wide range of drilling and tapping capacities. Designed for easy operation with an electromagnetic clutch for precise automatic feed control that can be activated from the feed crank handle or by the lever on the front of machine head.

Standard Features and Equipment:

- Drilling capacity in steel: 1.97" (50mm) maximum
- Drilling capacity in cast iron: 2.36" (60mm) maximum
- Tapping capacity in steel: 1.68" (42mm) maximum
- Tapping capacity in cast iron: 2" (50mm) maximum
- Automatic feed reversing system for tapping
- Automatic feed and cut-off by electromagnetic clutch
- Hardened and ground high quality steel gears
- Speed plate and selecting levers on front of head
- Gear box lubrication by automatic pump
- Machine base with 2 T-slots, coolant tank and pump
- Large rotating table with 3 T-slots
- Feed crank wheel for manual feed
- Front hand wheel for fine feed work
- Depth scale and adjustable depth stop
- Automatic tool ejector
- Work Light
- Built-in low voltage electrical equipment in machine head
- Emergency STOP
- Drill guard with microswitch

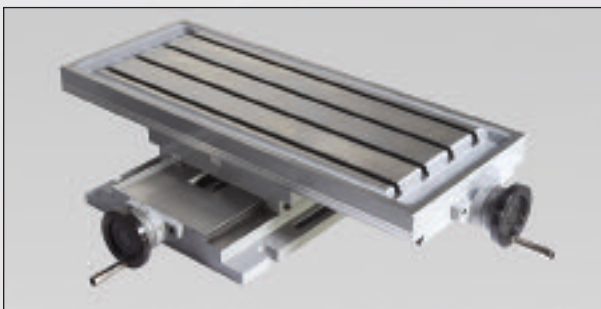

Optional **MB-5D** 18.5" x 11.5" cross slide table



BC50VE

Capacities, Specifications and Dimensions

Standard Models	BC40V	BC40VE	BC50V	BC50VE
Capacities:				
Maximum drilling capacity in steel	1.57" (40mm)	1.57" (40mm)	1.97" (50mm)	1.97" (50mm)
Maximum drilling capacity in cast iron	1.97" (50mm)	1.97" (50mm)	2.36" (60mm)	2.36" (60mm)
Maximum tapping capacity in steel	1.42" (36mm)	1.42" (36mm)	1.65" (36mm)	1.65" (36mm)
Maximum tapping capacity in cast iron	1.65" (36mm)	1.65" (36mm)	1.97" (50mm)	1.97" (50mm)
Specifications:				
Spindle taper	4MT	4MT	4MT	4MT
Quill diameter	3.46" (87.9mm)	3.46" (87.9mm)	3.46" (87.9mm)	3.46" (87.9mm)
Spindle travel (drilling depth)	7.87" (200mm)	7.87" (200mm)	7.87" (200mm)	7.87" (200mm)
Main motor power	4 Hp (3 Kw)	4 Hp (3 Kw)	5.5 Hp (4 Kw)	5.5 Hp (4 Kw)
Coolant pump motor power	.1 Hp (.07 Kw)	.1 Hp (.07 Kw)	.1 Hp (.07 Kw)	.1 Hp (.07 Kw)
No. of variable speeds ranges and type	3 mechanical	3 electronic	3 mechanical	3 electronic
Low range (rpm)	72-240	30-230	72-240	30-230
Med range (rpm)	240-720	90-730	240-720	90-730
High range (rpm)	720-2200	190-1500	720-2200	190-1500
Number of automatic feeds	4	4	4	4
Auto feed range	.0039/.0079/.118/.157 (in./rev.) (0.1/0.2/0.3/0.4 mm/rev)			
Floor Drill Dimensions and Weights				
Height (A)	81.9" (2080mm)	81.9" (2080mm)	83.5" (2120mm)	83.5" (2120mm)
Base: Length x Width (B)	31.9" x 26.3" (810x540mm)	31.9" x 26.3" (810x540mm)	33.9" x 21.7" (860x550mm)	33.9" x 21.7" (860x550mm)
Base to spindle (C)	46.1" (1170mm)	46.1" (1170mm)	49" (1246mm)	49" (1246mm)
Spindle center to column (D)	15.15" (385mm)	15.15" (385mm)	14.56" (370mm)	14.56" (370mm)
Spindle to Table (E)				
Minimum	1.97" (50mm)	1.97" (50mm)	1.57" (40mm)	1.57" (40mm)
Maximum	27.16" (690mm)	27.16" (690mm)	26" (660mm)	26" (660mm)
Worktable: Length x Width (F)	18.9" x 22" (480x560mm)	18.9" x 22" (480x560mm)	20.5" x 24.4" (520x620mm)	20.5" x 24.4" (520x620mm)
Base height (G)	5.31" (135mm)	5.31" (135mm)	5.71" (145mm)	5.71" (145mm)
Column diameter (H)	7.09" (180mm)	7.09" (180mm)	7.87" (200mm)	7.87" (200mm)
Net weight	1,455 lbs (660kg)	1,455 lbs (660kg)	1,675 lbs (760kg)	1,675 lbs (760kg)
Shipping weight	1,653 lbs (750kg)	1,653 lbs (750kg)	1,874 lbs (850kg)	1,874 lbs (850kg)
Shipping dimension (Length x Width x Height)	32" x 51" x 91" (.8 x 1.3 x 2.3m)		36" x 55" x 91" (.9 x 1.4 x 2.3m)	

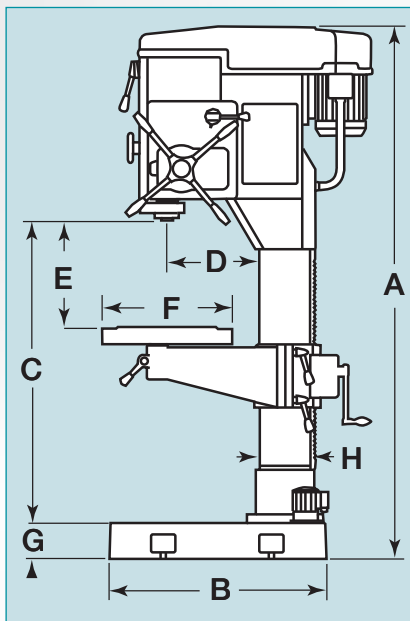

Standard motor: 1800 rpm

Model	Spindle speeds (rpm)
BC40V	Mechanical Variable Speed: 72-1800 rpm
BC50V	Mechanical Variable Speed: 36-1800 rpm

Standard Fixed Table Models

Model	Description
1BC40V	30.3" (770mm) drill with Fixed Table
1BC50V	29" (736mm) drill with Fixed Table
1BC40VE	30.3" (770mm) drill with Fixed Table
1BC50VE	29" (736mm) drill with Fixed Table

Headstock mounted Speed Selector Lever and Digital Display for operator convenience and fast and easy speed selection



Built-in low voltage electrics, automatic tool ejection system lever





Series T/Z/X/A/B

Round-column Multiple Head, Fixed Table and Oversized Table Drills

Clousing IBARMIA industrial drilling machines mounted to a fixed or oversized table offer greater ease in positioning the workpiece and the flexibility to handle bulky or heavy workpieces.

Multiple Head drilling machines are ideal for work where the workpiece requires more than one operation. Each drill head on a multiple head drill can be equipped differently to perform the operation required by that head such as... automatic drilling cycle, automatic tapping or any of the equipment offered. Drilling machines can be set-up with rotating heads adding flexibility.



3AX32



1B35

3AX32 23.6" (600mm) Geared-drive 3 head drill.

1B35 29.1" (740mm) Geared-drive drill mounted to standard fixed table.

Multiple Spindle Dimensional Drawings

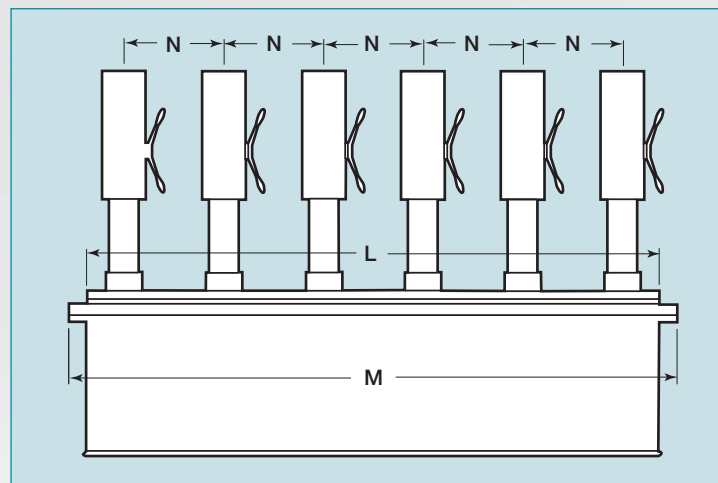
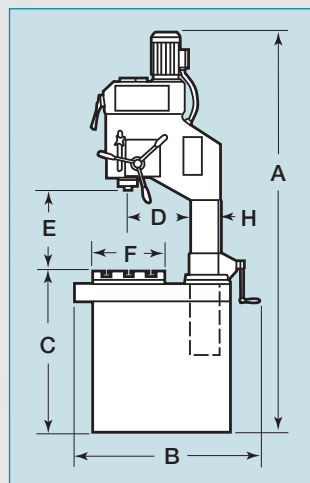
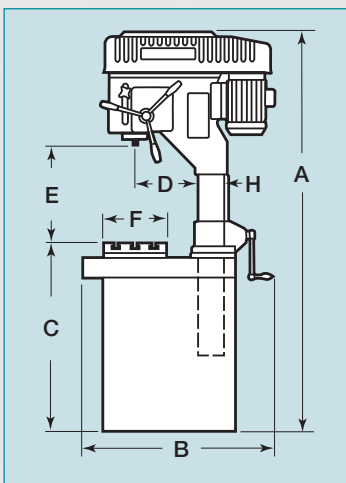



Series T/Z/X/A/B

Round-column Optional Equipment

Model	Description:
7044	Coolant System with separate tank (all models)
7022	Worklight with magnetic base (all models)
PST	Cycle or spindle turn START foot pedal
PSR	Spindle reverse foot pedal (for tapping)
MCC-KT	Cross Slide Table 13.8" x 10.8" (K/T Series)
MCC-ZX	Cross Slide Table 15" x 8.7" (Z/X Series)
MCC-X40	Cross Slide Table 15" x 8.7" (X40 Series)
MB-5D	Cross Slide Table 16" x 12" (X model 35/A/B Series)
SeriesT	<i>(Factory Installed only)</i>
MG-T	Rotating table
PKA	Floor Cabinet with 2 shelves
PKB	Floor Cabinet with door and drawer
SeriesZ	<i>(Factory Installed only)</i>
MG-Z	Rotating table
MGI-Z	Tilting Rotating Table
TAK-Z	Digital rpm read-out (V models only)
UC-Z	Union, dragging cone and assembly for multi-spindle head
SeriesX	<i>(Factory Installed only)</i>
MG-X	Rotating table (X-32 Models)
MGI-X	Tilting Rotating Table
RPF-X	Automatic pitch controlled tapping with single speed brake-motor
RPF-ANR-X	Automatic pitch controlled tapping with pneumatic rapid approach
HGP-X	Master guide spindle and nut set for automatic pitch controlled tapping
UC-X	Union, dragging cone and assembly for multi-spindle head
SeriesA/B	<i>(Factory Installed only)</i>
RPF-A	Automatic pitch controlled tapping with single speed brake-motor
RPF-ANR-A	Automatic pitch controlled tapping with pneumatic rapid approach
HGP-A	Master guide spindle and nut set for automatic pitch controlled tapping
ACNL-B	Pneumatic counterbalance with rapid approach and retreat
ACNL-S-B	Pneumatic counterbalance with rapid approach and retreat for tube and profile drilling
ACNL-RPF-B	Pneumatic counterbalance with rapid approach and retreat with controlled tapping
AR-A	50% lower feed rate range
DLM-A	Mechanical spotface device
CN-A	Pneumatic counterbalance for spindle return
UC-A	Union, dragging cone and assembly for multi-spindle head
GM-A	Multi-spindle head guide rod
PM-B	Start-stop and emergency stop pendant control
SC-B	8" column riser



PST
Cycle or spindle turn START foot pedal

PSR
Spindle reverse foot pedal (for tapping)



RS
Automatic feed reversing system for tapping. (standard on series T/Z/X/A/B-RS models)



TAK
Digital rpm display. (for series Z-V models)

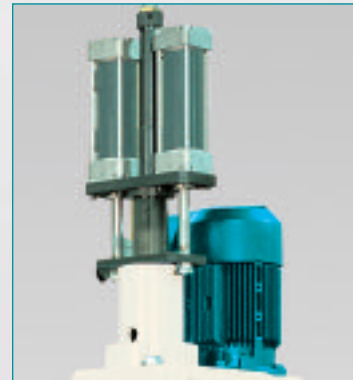

RPF-ANR
Automatic pitch controlled tapping with pneumatic rapid approach. (standard on series X/A/B models)



RPF
Automatic pitch controlled tapping with single speed brake-motor. (for series X/A/B models)



MGM rotating table with 3 T-slots on one side and a vise on the other for model Z34 & X34



MG
Rotating table with 3 T-slots. (for series Z/X-32 models standard on all other models)



MGI
Rotating table with 3 T-slots and tilting support. (for series Z/X/A/B models)



ACNL
Pneumatic counterbalance for automatic drilling cycle with rapid approach, working feed and rapid retract. (for series **B** models)

ACNL-S
Pneumatic counterbalance for automatic drilling cycle with two rapid approaches, and rapid retract, for tube and profile drilling. (for series **B** models)

Assembly for Multi-Spindle Heads

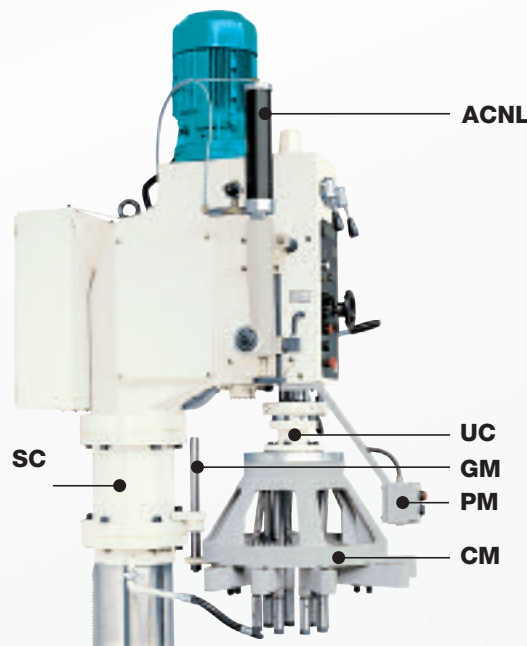

ACNL Automatic drilling cycle with rapid approach, working feed and rapid retract, with additional pneumatic counterweight function for the multi-spindle head.

UC Union, dragging cone and assembly of the multi-spindle head.

CM Multi-spindle head with fixed or adjustable spindle.

GM Multi-spindle head guide rod.

PM START/STOP and emergency STOP control extension.

SC 8" column riser for greater distance between spindle nose and worktable

Cross Slide Tables

Series K/L



MCC-KT 13.8" x 10.8" Cross Slide Table for KL & TL models

Series X/Z

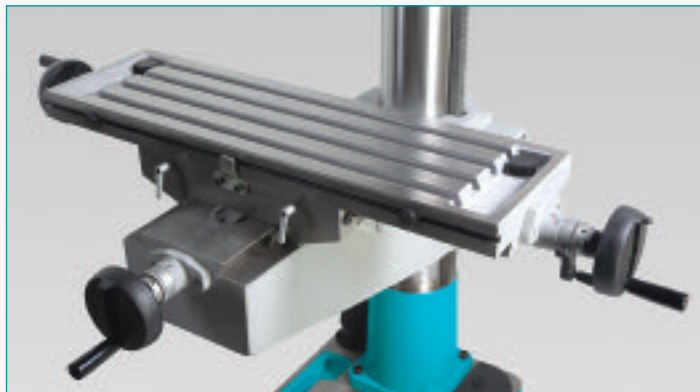

MCC-XZ 15" x 8.7" Cross Slide Table for X32/34 & Z32/34 models

Series K/L

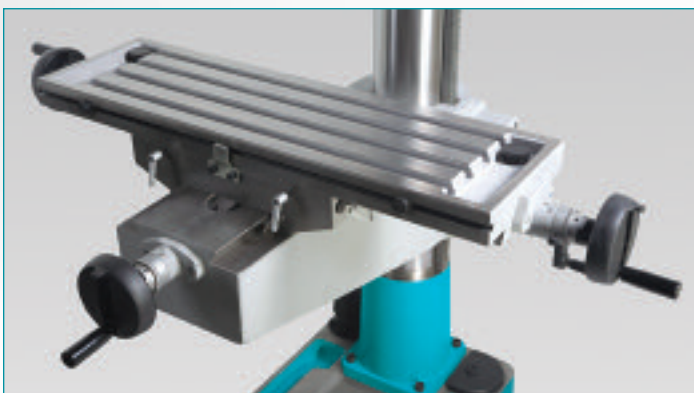

MCC-X40 15" x 8.7" Cross Slide Table for X40 & Z40 Models

Series K/L

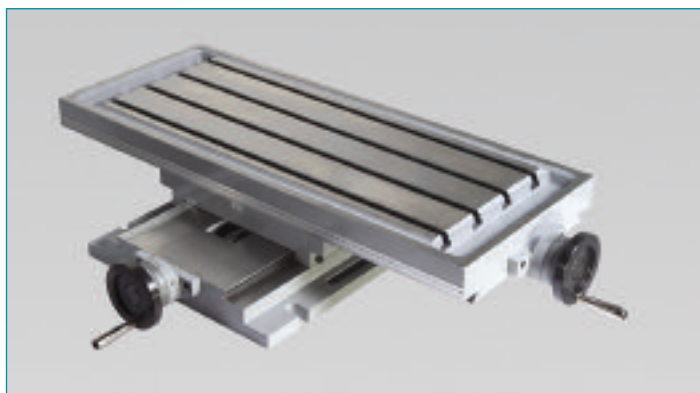

MB-5D 18.5" x 11.8" Cross Slide Table for A, B & C models



Your Single Source for Machine Tools

Clausing Precision Drills

- Clausing Belt-drive Drills
- Clausing Geared-head Drills
- Clausing Radial Drills

Clausing Precision Mills

- Clausing Bed Mills
- Clausing CNC Bed Mills
- Clausing Knee Mills
- Clausing CNC Knee Mills

Clausing Precision Lathes

- Clausing/Colchester Geared Head Lathes
- Clausing/Colchester Professional V.S. Lathes
- Clausing Large Swing Standard and CNC Lathes
- Clausing/Metosa Standard and CNC Lathes

Clausing Precision Grinders

- Clausing Manual Grinders
- Clausing 2 & 3 Axes Hydraulic Grinders
- Clausing ASDII Automatic Grinders
- Clausing ASDIII Automatic Grinders

Clausing Precision Cutting Machines

- Clausing/Kalamazoo Horizontal Bandsaws
- Clausing/Kalamazoo Vertical Bandsaws
- Clausing/Kalamazoo Tilt Frame Miter Bandsaws
- Clausing/Kalamazoo Cold Saws

For detailed catalogs of the full line of Clausing Machine Tools visit our Web Site:

www.clausing-industrial.com

or e-mail us and request an electronic (pdf) catalog at:

info@clausing-industrial.com

Your Authorized Clausing Precision Machine Tools Distributor



Clausing Industrial, Inc.
 1819 North Pitcher Street
 Kalamazoo, Michigan 49007-1886
 Phone: 269-345-7155
 Fax: 269-345-5945
 Information: info@clausing-industrial.com

Call Toll Free: 800-323-0972
or visit our website
www.clausing-industrial.com