

Clausing Horizontal Bandsaws

600Group

A Complete Line of Precision General Purpose Horizontal Bandsaws



- Precision Manual Bandsaws
- Precision Semi-Automatic Bandsaws
- Precision Fully-Automatic Bandsaws



Clausing 10" (254mm) Wet Cutting Bandsaw

Features:

- 2 Hp (1.5kw) drive motor with magnetic starter and overload protection
- Quick positioning 45° vise
- Cast iron bed
- Totally enclosed transmission
- Quick and simple speed change
- 1" (254mm) wide blade
- Blade cleaning brush
- Solid carbide blade guides with rollers
- Recirculating coolant system with application through both guides
- Stock stop
- Easily adjusted head feed
- Head control is hydraulic cylinder operated by needle valve
- Two (2) year limited warranty

Specifications

Model	HBS-1018
Type	Horizontal wet cut
Drive Motor	2 Hp. (1.5kw) 110v or 220v 1 Ph 230v or 460v 3 Ph
Blade Wheel Dia.	15.4" (391mm) flanged, cast iron
Blade	1" x .035" x 11'-4.5" (25 x .9 x 3645mm)
Bed Height	22" (559mm)
Blade Speeds	(4) 80, 200, 300, 430 fpm (24, 61, 91, 131 mpm)
90° Cutting Capacity	
Round	10" (254mm)
Rectangular	18" x 6" or 10" x 16" (457x152 or 254x 406mm)
45° Cutting Capacity	
Round	8" (203mm)
Rectangular	7"x 10" (179 x 254mm)
Width	80.25" (2038mm)
Depth	33.13" (842mm)
Height (head-up)	45.25" (1150mm)
Height (head-down)	45.25" (1150mm)
Net Weight	704 lbs (319kg)
Shipping Weight	900 lbs (408kg)

Accessories

P10	Stock Stand Assembly 21" - 30"
RT0516	Roller Table Assembly 5' x 16"
RT1016	Roller Table Assembly 10' x 16"
BT01	Bandsaw Blade Tension Gauge

Cutting Capacities:

Capacity at 90°

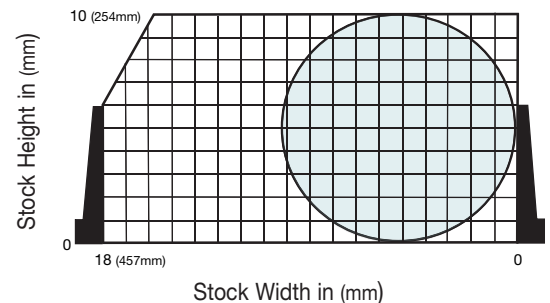

Capacity at 45°

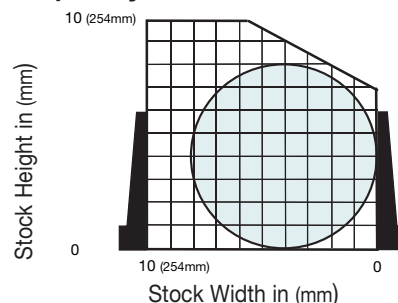



Clausing 11" (280mm) Manual & Semi-Automatic 13" (330mm) Semi-Automatic Bandsaw

Features:

- 2 Hp (1.5kw) drive motor with magnetic starter and overload protection
- Solid carbide blade guides with rollers
- 1" (25mm) wide blade
- Blade tension indicator
- Totally enclosed transmission
- Rapid clamp and quick release 45° vise
- Blade guards easily removed for easy blade loading from the top
- Low voltage and overload protection
- Infinitely variable blade speed
- Self-propelled blade cleaning brush
- Additional stop/start control at the rear of the machine
- Coolant application through both guides
- Removable coolant tank
- Easily adjusted hydraulic head feed with counter-balance spring
- Automatic blade shut-off at end of cut
- Heavy-duty cast iron vise bed
- Infinitely variable hydraulic head feed with electrical release mechanism, allows one-time setting of feed rate on each batch run SA models
- Stock stop assembly automatically swings clear of stock during cut SA models
- Two (2) year limited warranty

Specifications

Model	HB280M/HB280SA	HB330SA
Type	Horizontal wet cut	
Drive Motor	2 Hp. (1.5kw) 110v or 220v 1 Ph 230v or 460v 3 Ph	
Blade Wheel Dia.	14" (356mm)	16" (406mm)
Blade	1" x .035" x 11' (25 x .9 x 3353mm)	1.25" x .042" x 12'-6" (32 x 1 x 3810mm)
Bed Height	28" (711mm)	
Blade Speeds	Infinitely variable 85-400 fpm (26-122 mpm)	
90° Cutting Capacity		
Round	11" (280mm)	13" (330mm)
Rectangular	9" x 16" (228 x 406mm)	10" x 16" (254 x 406mm)
45° Cutting Capacity		
Round	8.5" (216mm)	9" (228mm)
Rectangular	7" x 8" (178 x 203mm)	8" x 9" (203 x 228mm)
Width	69" (1753mm)	70.75" (1797mm)
Depth	48" (1219mm)	48" (1219mm)
Height (head-up)	78.5" (1994mm)	79.87" (2028mm)
Height (head-down)	46.5" (1181mm)	48" (1219mm)
Net Weight	750 lbs (340kg)	960 lbs (435kg)
Shipping Weight	975 lbs (442kg)	1095 lbs (497kg)

Design and specifications are subject to change without notice.

Accessories

- P10 Stock Stand Assembly 21" - 30"
- RT0516 Roller Table Assembly 5' x 16"
- RT1016 Roller Table Assembly 10' x 16"
- BT01 Bandsaw Blade Tension Gauge

Cutting Capacities:

11" Capacity at 90° / Capacity at 45°

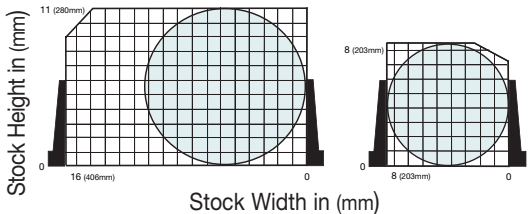

13" Capacity at 90° / Capacity at 45°

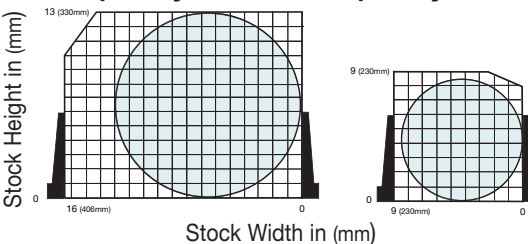



Clausing 12" (305mm) Wet Cutting Semi-Automatic Miter Bandsaw

Features:

- 0°-45° Miter cutting, make angle cuts without swinging material to be cut
- 2 Hp (1.5kw) main drive with magnetic starter and overload protection
- Variable speed drive
- 230/460 60 cycle 3 phase electricals
- Recirculating coolant system with application through both guides
- Solid carbide blade guides with rollers
- Quick position vise
- Automatic shut-off at end of cut
- Totally enclosed transmission
- Blade cleaning brush
- Cast iron bed
- 1" (254mm) wide blade
- Stock stop
- Easily adjusted head feed with power lift
- Two (2) year limited warranty

Specifications

Model	MS1218VS
Drive Motor	2 Hp, (1.5kw) 230/460v 3 phase
Hydraulic Motor	0.25 Hp (.19kw)
Coolant Pump	0.125 Hp (.1kw)
Band Wheel Dia.	15.4" (391mm)
Blade	1" x .035" x 11'-4.5" (25 x .9 x 3467mm)
Bed Height	21.75" (552mm)
Vise Opening	18" (457mm)
Blade Speeds	80-360 fpm (24-110 mfm) variable speed
90° Cutting Capacity	
Round	12" (305mm)
Square	10" x 10" (254 x 254mm)
Rectangular	10" x 16" (254 x 406mm)
45° Cutting Capacity	
Round	8" (203mm)
Square	8" x 8" (203 x 203mm)
Rectangular	8" x 12" (203 x 305mm)
Width	75" (1905mm)
Depth (with stock stop)	34" (49.5") (864(1257)mm)
Height (head-up)	64" (1626mm)
Height (head-down)	41" (1041mm)
Net Weight	880 lbs (400kg)
Shipping Weight	1,100 lbs (500kg)

Accessories

- P10 Stock Stand Assembly 21" - 30"
- RT0516 Roller Table Assembly 5' x 16"
- RT1016 Roller Table Assembly 10' x 16"
- BT01 Bandsaw Blade Tension Gauge

Cutting Capacities:

Capacity at 90°

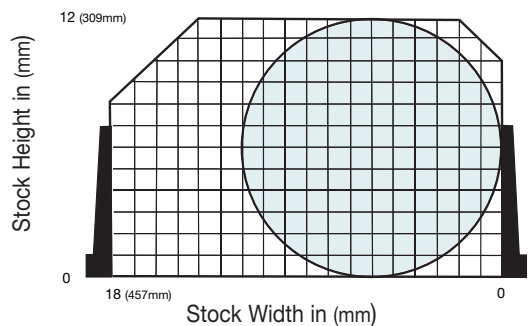

Capacity at 45°

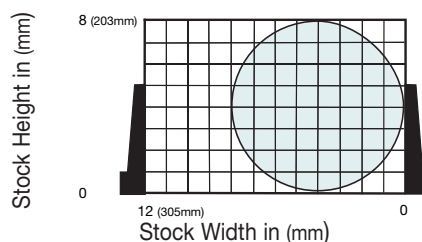

Clausing 13" (330mm) Semi-Automatic Swivel Head Miter Bandsaw

Features:

- Advanced hydraulic system provides dependable power for powered clamping and raising the saw head at end of cut
- Full stroke machine vise for tight clamping of any material from operator's panel
- Swivel sawhead allows the operator to accurately pivot head for angle cuts from 0°, for a 90° cut, to 60°
- Carbide blade guides provide excellent stability for the saw blade
- Variable blade speed
- Power chip brush removes chip from the blade extending blade life
- Integrated coolant system
- Cast iron moveable guide arms provide rigidity and stability for an accurate cut
- Flushing hose
- Adjustable work stop
- Tool box with tools
- Manual & parts list
- Two (2) year limited warranty

Available in Manual and Automatic Models

Accessories

- P10 Stock Stand Assembly 21" - 30"
- RT0516 Roller Table Assembly 5' x 16"
- RT1016 Roller Table Assembly 10' x 16"
- BT01 Bandsaw Blade Tension Gauge

Cutting Capacities:

MS1318SA Capacity at 90°

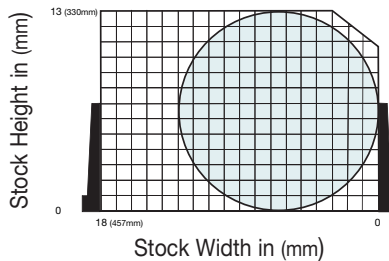

MS1318SA Capacity at 45°

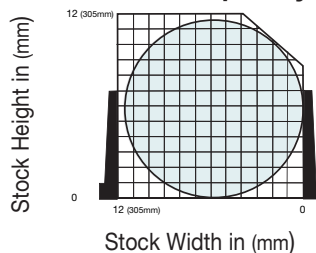

Specifications

Model	MS1318SA
Drive Motor	3 Hp (2.2kw)
Hydraulic Motor	.25 Hp (.19kw)
Hydraulic Oil Capacity	2 gallons (7.5 liters)
Coolant Motor	.125 Hp (.1kw)
Coolant Capacity	7.8 gallons (7.5 liters)
Blade Speeds (Inf. variable)	102-377 fpm (31-115 mpm)
Blade Size	1" x .035" x 13'-7" (25 x .9 x 4140mm)
Swivel Angle Range	0° to 60°
Cutting Capacity	
Round @ 90°	13" (330mm)
Round @ 45°	11.5" (292mm)
Round @ 60°	8.7" (220mm)
Square @ 90°	10.6" (270mm)
Square @ 45°	10.5" (268mm)
Square @ 60°	8.7" (221mm)
Rectangular @ 90°	18.5" x 10.6" (470 x 269mm)
Rectangular @ 45°	10.5" x 10.5" (268 x 268mm)
Rectangular @ 60°	8.7" x 8.7" (220 x 220mm)
Bed Height	27.5" (700mm)
Dimensions:	
Length	75" (1905mm)
Width	34" (863mm)
Height	55.5 (1410mm)
Net Weight	1,400 lbs (635kg)
Shipping Weight	1,850 lbs (839kg)

Design and specifications are subject to change without notice.



Clausing 12" (305mm), 18" (460mm) & 20" (508mm) Manual and Semi-Automatic Miter Bandsaws

Features:

- Variable speed drive, 82-260 fpm
- Automatic head elevation control
- Amplify valve/auto adjust cut feed rate
- Power-driven blade cleaning brush and coolant cleaning flush hose
- Carbide and roller blade guides to ensure perfect alignment and straight cuts
- Quick adjusting carbide saw guide
- Hydraulic quick-action vise with toothrack and push-jaw feature, easily adjusted to accommodate stock size.
- Motorized turntable
- Automatic motorized turntable on BS760MA
- Quick acting mechanical blade tension
- Pressure compensation feed-rate control
- Light to show cutting area
- Guarded blades and wheel covers
- Blade, tools and tool box, manual
- Two (2) year limited warranty

Specifications	BS450M	BS760M/BS760MA	BS1000M
Drive Motor*	5 Hp, (3.7kw) 230/460v	7.5 Hp, (5kw) 230/460v	15 Hp (10kw), 230/460v
Hydraulic Motor	1 Hp (.7kw)	2 Hp (1.4kw)	2 Hp (1.4kw)
Hydraulic oil capacity	11 gallons (42 liters)	14.4 gallons (55 liters)	14.4 gallons (55 liters)
Bandwheel Dia.	16.5" (420mm)	21.65" (550mm)	24.4" (620mm)
Blade Speeds V.S.	82-260 f/min (25-80 m/min) Variable Speed		
Blade	1.25" x .042" x 13'-6" (32 x 1 x 4115mm)	1.5" x .051" x 18'-5" (38 x 1.3 x 5300mm)	2.1" x .063 x 23'-.057" (53 x 1.3 x 7012mm)
Coolant	Recirculating	Recirculating	Recirculating
Coolant Capacity	16 gallons (60 liters)	17 gallons (64 liters)	18 gallons (68 liters)
90° Cutting Capacity			
Round	12.6" (320mm)	18" (457mm)	20" (508mm)
Square	12.6" (320mm)	18" (457mm)	20" (508mm)
H Beam	20" x 12.6" (508 x 320mm)	30" x 16" (762 x 406mm)	40" x 20" (1016 x 508mm)
60° Cutting Capacity			
Round Solid/Tube	11.8"/12.6" (300/320mm)	16.5"/18.1" (420/460mm)	16"/20" (406/508mm)
Square Solid/Tube	11.8"/12.6" (300/320mm)	16.5"/18.5" (420/460mm)	16"/20" (406/508mm)
H Beam	14" x 12.6" (356x320mm)	23.2" x 15.7" (590x400mm)	31.5" x 20" (800x508mm)
45° Cutting Capacity			
Round Solid/Tube	9"/9" (230/230mm)	13"/15.9" (330/404mm)	13.78"/20" (350/508mm)
Square Solid/Tube	9"/12.6" (230/320mm)	13"/15.75" (330/400mm)	13.78"/20" (350/508mm)
H Beam	9" x 12.6" (230 x 320mm)	16" x 15.75" (406x400mm)	23.2" x 20" (590/508mm)
30° Cutting Capacity			
Round Solid/Tube	3.27"/3.27" (83/83mm)	8.03"/8.03" (203/203mm)	13"/13" (330/330mm)
Square Solid/Tube	3.27"/3.27" (83/83mm)	8.03"/8.03" (203/203mm)	13"/13" (330/330mm)
H Beam	3.27" x 12.6" (83x320mm)	8.03" x 15.75" (203x400mm)	13" x 17.32" (330x440mm)
Height (head-up) (A)	71.3" (1811mm)	94.5" (2400mm)	113.9" (2893mm)
Height (head-down) (B)	44.6" (1132mm)	53.1" (1348mm)	56" (1422mm)
Width (C)	82.7" (2100mm)	102.4" (2600mm)	134" (3400mm)
Base Width (D)	76" (1930mm)	80.3" (2039mm)	104.7" (2660mm)
Bed Height (E)	25" (635mm)	24.8" (630mm)	25.6" (650mm)
Depth (F)	68.9" (1750mm)	86.6" (2200mm)	89.4" (2270mm)
Net Weight	3,902 lbs (1770kg)	5,731 lbs (2600kg)	7,040 lbs (3193kg)
Shipping Weight	4,343 lbs (1970kg)	6,393 lbs (2900kg)	7,700 lbs (3492kg)

*Other voltages optional.

Specifications are subject to change without notice.

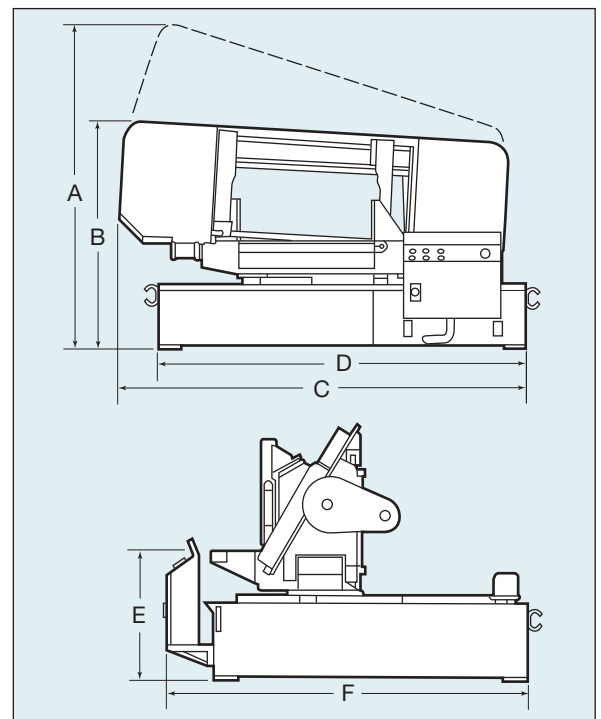

Clausing 12" (305mm) Automatic Bandsaw

Designed for rugged production use, the Clausing KC12AX bandsaw offers high production output and heavy duty performance in both semi-automatic and fully automatic operation. A powerful drive motor provides the power, and the optional hydraulic bundling attachment makes multiple cuts easy. The hydraulic shuttle feed system offers up to nine indexes.

Features:

- Full or semi-automatic operation
- Infinitely variable blade speeds
- LED blade speed readout
- Vise clamps work piece both sides of blade
- Hydraulic down feed
- Automatic height setting feature
- Auto shutoff at end of material or after preset number of cuts
- Front-mounted digital length gauge
- Blade breakage/stoppage switch
- 110v. control circuit
- Overload protection
- Recirculating coolant system
- Shuttle vise
- (1) general purpose bi-metal blade
- Flushing hose for cleanup
- Operator's manual
- Two (2) year limited warranty

Accessories

- CM1201 Chip Conveyor
- CM1202 Hydraulic Bundle Clamps
- CM1601 Variable Vise Pressure System
- SA13 Heavy-duty Roller Table 5' x 13"
- SA12 Heavy-duty Roller Table 10' x 13"
- P10 Stock Stand Assembly 21" - 30"

Cutting Capacities:

Capacity at 90°

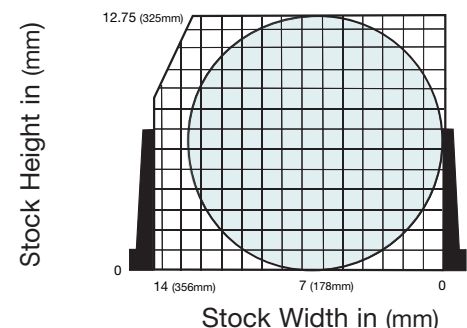

Specifications

Model	KC12AX
Motor	5 Hp (3.75 kw), 230/460v 3ph*
Hydraulic Pump Motor	1 Hp (.75 kw)
Hydraulic Oil Capacity	6.5 gallons (25 liters)
Band Wheel Dia.	16" (406mm)
Blade Speeds (Variable speed)	95-395 fpm (30-120 mpm)
Blade Size	1.25"x.042"x12'-6" (32x1x3810mm)
Coolant	Recirculating
Coolant Capacity	10 gallons (39 liters)
90° Cutting Capacity	
Round	12.75" (300 mm)
Rectangular	12.75" x 12.6" (300 x 320mm) 7.9" x 14.2" (200 x 360mm)
**Bundle Cutting Width	6.5" to 10" (165 to 254mm)
**Bundle Cutting Height	2" to 8" (51 to 203mm)
Feed Length/Index	15.75" (400mm)
Max.Feed (9 times)	141.75" (3600 mm)
Length	76.5" (1943 mm)
Width	76.5" (1943 mm)
Height (head-down)	57" (1449 mm)
Height (head-up)	73" (1854 mm)
Bed Height	26" (660 mm)
Net Weight	3,090 lbs (1388 kg)
Shipping Weight	3,400 lbs (1542 kg)

*Other voltages optional.

**When machine is equipped with optional hydraulic bundle cutting attachment.

Design and specifications are subject to change without notice.

Clausing 10" (254mm) & 13" (330mm) Automatic Bandsaw

Features:

- Variable speed drive
- LED blade speed display
- Precise cut off length setting
- Auto head-elevation and quick approach control
- Piece counter with auto shutoff
- Multiple stroke counter for long pieces, 9 -15.75" (230-400mm) strokes standard
- Amplify valve/auto adjust cut feed rate
- Power-driven blade cleaning brush and coolant cleaning flush hose
- Idle wheel motion detector provides auto shutoff for blade jams or breakage
- Carbide and roller blade guides
- Shuttle vise back-jaw feed method (no need for front stop)
- Split vise allows cutting to within 2" (50mm) of bar end, automatically
- Unique two-way vise jaw
- Hydraulic blade tension control
- Light to show cutting area
- Floating, two way open, rear vice jaws
- Guarded blades and wheel covers
- Blade, tools and tool box and manual
- Two (2) year limited warranty



Specifications	BS250HAS	BS300HAS
Drive Motor*	3 Hp, (2.2kw) 230/460v	5 Hp, (3.7kw) 230/460v
Hydraulic Motor	1 Hp (.75kw)	1 Hp (.75kw)
Hydraulic oil capacity	9.3 gallons (35 liters)	9.3 gallons (35 liters)
Bandwheel Dia.	16.5" (420mm)	16.5" (420mm)
Blade Speeds	65-260 f/min (20-80 m/min) Variable Speed	
Blade	1.25" x .042" x 12' (32 x 1 x 3658mm)	1.25" x .042" x 12'-6.5" (32 x 1 x 3823mm)
Coolant	Recirculating	Recirculating
Coolant Capacity	15 gallons (57 liters)	15 gallons (57 liters)
Vise Opening	12.5" (318mm)	13.78" (350mm)
90° Cutting Capacity		
Round	10.5" (268mm)	13" (330mm)
Square	10" x 10" (254 x 254mm)	12" x 12" (305 x 305mm)
Rectangular	12" x 7" (305 x 178mm)	13.5" x 9.84" (343 x 250mm)
Bundle Cutting**	8" x 5.5" (203 x 140mm)	10" x 6.5" (254 x 165mm)
Feed Length/Index	15.75" (400mm)	15.75" (400mm)
Max. Feed (9 times)	141.75" (3600mm)	141.75" (3600mm)
Height (head-up) (A)	62" (1575mm)	75" (1905mm)
Height (head-down) (B)	45" (1143mm)	51" (1295mm)
Width (C)	69" (1753mm)	74" (1880mm)
Base Width (D)	50" (1270mm)	55" (1397mm)
Bed Height (E)	22" (560mm)	23" (585mm)
Base Depth (F)	29" (737mm)	29" (737mm)
Depth (G)	44.17" (1120mm)	44.17" (1120mm)
Depth (H)***	77" (1955mm)	77" (1955mm)
Net Weight	2,795 lbs (1269kg)	2,895 lbs (1313kg)
Shipping Weight	3,295 lbs (1495kg)	3,395 lbs (1540kg)

Cutting Capacities:

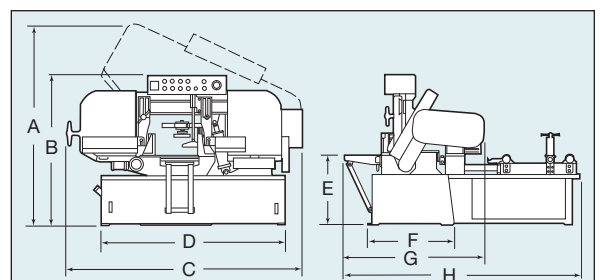
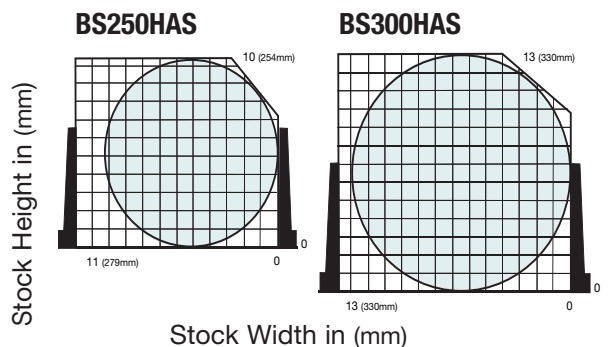

*Other voltages optional. **With optional Bundle Clamp.

*** Depth with optional infeed roller table. Specifications are subject to change without notice.

Clausing 15" (380mm) & 18" (460mm) Automatic Bandsaw

Features:

- Variable speed drive
- LED blade speed display
- Precise cut off length setting
- Auto head-elevation and quick approach control
- Piece counter with auto shutoff
- Multiple stroke counter for long pieces, 9 -15.75" (230-400mm) strokes standard
- Amplify valve/auto adjust cut feed rate
- Power-driven blade cleaning brush and coolant cleaning flush hose
- Idle wheel motion detector provides auto shutoff for blade jams or breakage
- Carbide and roller blade guides
- Shuttle vise back-jaw feed method (no need for front stop)
- Split vise allows cutting to within 2" (50mm) of bar end, automatically
- Unique two-way vise jaw
- Hydraulic blade tension control
- Light to show cutting area
- Floating, two way open, rear vise jaws
- Guarded blades and wheel covers
- Blade, tools and tool box and manual
- Two (2) year limited warranty



Specifications	BS400HAS	BS450HAS
Drive Motor*	5 Hp, (3.7kw) 230/460v	7.5 Hp, (3.7kw) 230/460v
Hydraulic Motor	1 Hp (.7kw)	2 Hp (1.5kw)
Hydraulic oil capacity	11 gallons (42 liters)	14 gallons (53 liters)
Bandwheel Dia.	18.5" (470mm)	21.65" (550mm)
Blade Speeds	65-260 f/min (20-80 m/min) Variable Speed	
Blade	1.25" x .042" x 13'-6" (32 x 1 x 4115mm)	1.25" x .042" x 16' (32 x 1 x 4877mm)
Coolant	Recirculating	Recirculating
Coolant Capacity	15 gallons (57 liters)	20 gallons (76 liters)
Vise Opening	16.5" (420mm)	18.5" (470mm)
90° Cutting Capacity		
Round	16" (406mm)	18.11" (460mm)
Square	12.5" x 12.5" (320x320mm)	16" x 16" (406x406mm)
Rectangular	16" x 12.5" (406x320mm)	18" x 16" (680x406mm)
Bundle Cutting**	13" x 8" (330x203mm)	14" x 10" (355x254mm)
Feed Length/Index	15.75" (400mm)	19.68" (500mm)
Max. Feed (9 times)	141.75" (3600mm)	177" (4500mm)
Height (head-up) (A)	80" (2032mm)	90" (2286mm)
Height (head-down) (B)	52" (1320mm)	65" (1650mm)
Width (C)	82" (2082mm)	94" (2390mm)
Base Width (D)	71" (1800mm)	78" (1980mm)
Bed Height (E)	23" (585mm)	27" (686mm)
Base Depth (F)	31" (787mm)	35" (889mm)
Depth (G)	45.75" (1162mm)	52.76" (1340mm)
Depth (H)***	89" (2260mm)	92" (2337mm)
Net Weight	3,376 lbs (1531kg)	6,500 lbs (2948kg)
Shipping Weight	4,081 lbs (1851kg)	7,380 lbs (3347kg)

*Other voltages optional. **With optional Bundle Clamp.

*** Depth with optional infeed roller table. *Specifications are subject to change without notice.*

Cutting Capacities:

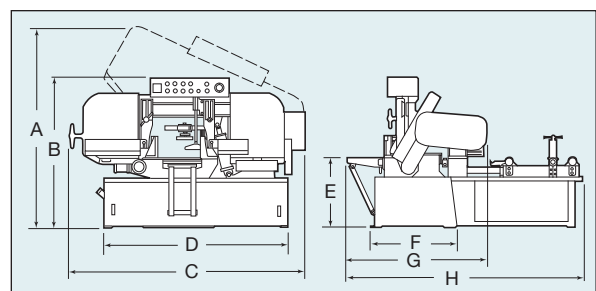
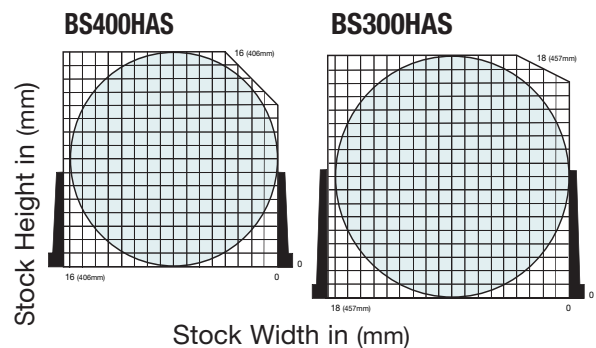

Clousing 13" (330mm) , 15" (380mm) & 18" (460mm) Automatic Bandsaw with Automatic NC Control

Features:

For GA-Series Models, input length and number of cuts data into the incorporated microcomputer with a easy-to-use keyboard, and the work-pieces will be automatically cut into the pre-set lengths and the required numbers...

- Variable speed drive
- LED blade speed display
- Precise cut off length setting
- Auto head-elevation and quick approach control
- Piece counter with auto shutoff
- Multiple stroke counter for long pieces, 9 -15.75" (230-400mm) strokes standard
- Amplify valve/auto adjust cut feed rate
- Power-driven blade cleaning brush and coolant cleaning flush hose
- Idle wheel motion detector provides auto shutoff for blade jams or breakage
- Carbide and roller blade guides
- Shuttle vise back-jaw feed method
- Split vise allows cutting to within 2" (50mm) of bar end, automatically
- Unique two-way vise jaw.
- Hydraulic blade tension control
- Light to show cutting area
- Floating, two way open, rear vice jaws
- Guarded blades and wheel covers
- Blade, tools and tool box and manual
- Two (2) year limited warranty



Specifications	BS300GA	BS400GA	BS450GA
Drive Motor*	5 Hp, (3.7kw) 230/460v	5 Hp, (3.7kw) 230/460v	7.5 Hp, (5kw) 230/460v
Hydraulic Motor	1 Hp (.7kw)	1 Hp (.7kw)	2 Hp (1.4kw)
Hydraulic oil capacity	9.3 gallons (35 liters)	11 gallons (42 liters)	14 gallons (53 liters)
Bandwheel Dia.	16.5" (420mm)	18.5" (470mm)	21.65" (550mm)
Blade Speeds	65-260 f/min (20-80 m/min) Variable Speed		
Blade	1.25" x .042" x 12'-6.5" (32 x 1 x 3823mm)	1.25" x .042" x 13'-6" (32 x 1 x 4115mm)	1.25" x .042" x 16' (32 x 1 x 4877mm)
Coolant	Recirculating	Recirculating	Recirculating
Coolant Capacity	15 gallons (57 liters)	20 gallons (76 liters)	25 gallons (95 liters)
Vise Opening	13.78" (350mm)	16.5" (420mm)	18.11" (460mm)
90° Cutting Capacity			
Round	13" (330mm)	16" (406mm)	18" (457mm)
Square	12" x 12" (305 x 305mm)	12.5" x 12.5" (318 x 318mm)	16" x 16" (406 x 406mm)
Rectangular	13" x 10" (330 x 254mm)	16" x 12.5" (406 x 318mm)	18" x 16" (457 x 406mm)
Bundle Cutting**	10" x 6.5" (254 x 165mm)	13" x 8" (330 x 203mm)	14" x 10" (355 x 254mm)
Feed Length/Index	15.75" (400mm)	15.75" (400mm)	19.68" (500mm)
Max. Feed (9 times)	141.75" (3600mm)	141.75" (3600mm)	177" (4500mm)
Height (head-up) (A)	75" (1905mm)	80" (2032mm)	90" (2286mm)
Height (head-down) (B)	51" (1295mm)	52" (1320mm)	65" (1651mm)
Width (C)	74" (1880mm)	82" (2083mm)	94" (2388mm)
Base Width (D)	55" (1400mm)	71" (1803mm)	78" (1981mm)
Bed Height (E)	23" (584mm)	23" (584mm)	27" (686mm)
Base Depth (F)	29" (737mm)	31" (787mm)	35" (889mm)
Depth (G)	44.17" (1122mm)	45.75" (1162mm)	52.76" (1340mm)
Depth (H)***	77" (1956mm)	89" (2260mm)	92" (2334mm)
Net Weight	2,655 lbs (1204kg)	3,376 lbs (1531kg)	6,500 lbs (12948kg)
Shipping Weight	3,205 lbs (1453kg)	4,081 lbs (1851kg)	7,380 lbs (3348kg)

Cutting Capacities:

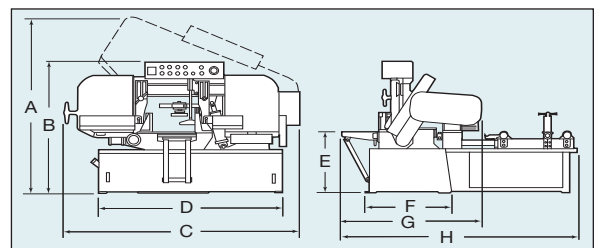
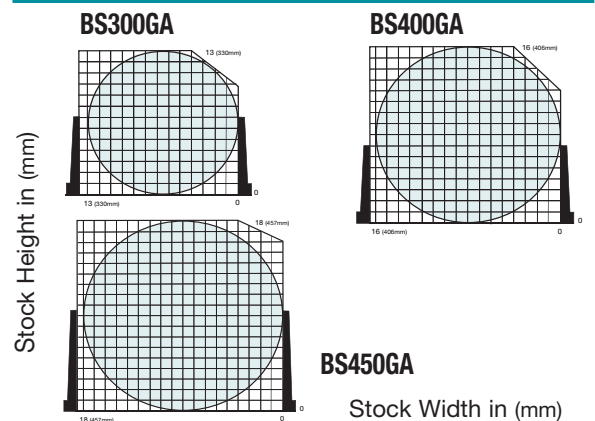

*Other voltages optional. **With optional Bundle Clamp.

*** Depth with optional infeed roller table. Specifications are subject to change without notice.

Clausing 15" (380mm) & 18" (460mm) Semi-Automatic Bandsaw

Features:

- Variable speed drive
- Automatic head elevation control
- Amplify valve/auto adjust cut feed rate
- Power-driven blade cleaning brush and coolant cleaning flush hose
- Carbide and roller blade guides to ensure perfect alignment and straight cuts
- Hydraulic quick-action vise with toothrack and push-jaw feature, easily adjusted to accommodate stock size.
- Floating roller feed mechanism
- Quick acting mechanical blade tension
- Pressure compensation feed-rate control
- Light to show cutting area
- Guarded blades and wheel covers
- Blade, tools and tool box and manual
- Two (2) year limited warranty



Specifications	BS400SA	BS450SA	BS760SA
Drive Motor*	5 Hp, (3.7kw) 230/460v	7.5 Hp, (5kw) 230/460v	7.5 Hp, (5kw) 230/460v
Hydraulic Motor	1 Hp (.1kw)	1 Hp (.1kw)	2 Hp (1.4kw)
Hydraulic oil capacity	7.5 gallons (28 liters)	9.3 gallons (35 liters)	9.3 gallons (35 liters)
Bandwheel Dia.	18.5" (470mm)	21.65" (216mm)	21.65" (216mm)
Blade Speeds	65-260 f/min (20-80 m/min) Variable Speed		
Blade	1.25" x .042" x 13'-6" (32 x 1 x 4115mm)	1.25" x .042" x 15'-4" (32 x 1 x 4674mm)	1.5" x .051" x 18'-5" (38 x 1.3 x 5500mm)
Coolant	Recirculating	Recirculating	Recirculating
Coolant Capacity	15 gallons (56 liters)	20 gallons (76 liters)	20 gallons (76 liters)
Vise Opening	16.5" (420mm)	18.11" (460mm)	30.5" (775mm)
90° Cutting Capacity			
Round	15.75" (400mm)	18" (457mm)	18" (457mm)
Square	12.5" x 12.5" (318 x 318mm)	16" x 16" (406 x 406mm)	18" x 18" (457 x 457mm)
Rectangular	16" x 12" (406 x 305mm)	18" x 16" (457 x 406mm)	30" x 16" (762 x 406mm)
Height (head-up) (A)	80" (2032mm)	90" (2286mm)	97" (2464mm)
Height (head-down) (B)	52" (1320mm)	65" (1651mm)	63" (1600mm)
Width (C)	82" (2083mm)	94" (2388mm)	107" (2718mm)
Base Width (D)	67" (1702mm)	71" (1803mm)	84" (2134mm)
Bed Height (E)	23" (584mm)	27" (686mm)	27" (686mm)
Base Depth (F)	29" (736mm)	33" (838mm)	33" (838mm)
Depth (G)	45.75" (1162mm)	52.56" (1335mm)	59.45" (1510mm)
Depth (H)**	72" (1829mm)	79" (2006mm)	99" (2515mm)
Net Weight	2,176 lbs (987kg)	3,080 lbs (1397kg)	3,310 lbs (1501kg)
Shipping Weight	2,651 lbs (1202kg)	3,630 lbs (1645kg)	3,885 lbs (1762kg)

Cutting Capacities:

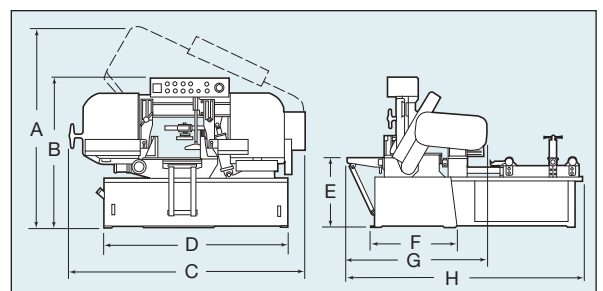
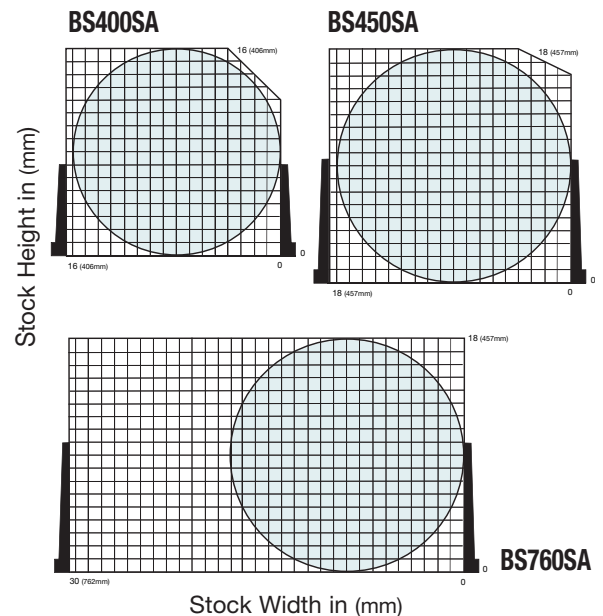

*Other voltages optional. ** Depth with optional infeed roller table.
Specifications are subject to change without notice.



Your Single Source for Machine Tools

Clausing Precision Drills

- Clausing Belt-drive Drills
- Clausing Geared-head Drills
- Clausing Radial Drills

Clausing Precision Mills

- Clausing Bed Mills
- Clausing CNC Bed Mills
- Clausing Knee Mills
- Clausing EVS Knee Mills

Clausing Precision Lathes

- Clausing/Colchester Geared Head Lathes
- Clausing/Colchester Professional V.S. Lathes
- Clausing/Harrison Standard Lathes
- Clausing Large Swing Standard and CNC Lathes

Clausing Precision Grinders

- Clausing Manual Grinders
- Clausing 2 Axes Hydraulic Grinders
- Clausing 3 Axes Hydraulic Grinders
- Clausing ASDII Automatic Grinders

Clausing Precision Cutting Machines

- Clausing Horizontal Bandsaws
- Clausing Vertical Bandsaws
- Clausing Tilt Frame Miter Bandsaws
- Clausing Cold Saws

For detailed catalogs of the full line of Clausing Machine Tools visit our Web Site:

www.clausing-industrial.com

or e-mail us and request an electronic (pdf) catalog at:

info@clausing-industrial.com

Your Authorized Clausing Precision Machine Tools Distributor



Clausing Industrial, Inc.
1819 North Pitcher Street
Kalamazoo, Michigan 49007-1886
Toll Free: 800-323-0972
Phone: 269-345-7155
Fax: 269-345-5945

Web Site: www.clausing-industrial.com
Information: info@clausing-industrial.com

Clausing Machine Tools used by:



To Build A Winning Race Car... You Need Precision Machine Tools!