

Clausing Heavy-duty Electronic Variable Speed (EVS) Vertical Knee Mills

Head mounted easy to use control



The LCD Display allows the operator to select spindle speeds quickly and accurately

Get the Advantages of an EVS Mill at a Very Affordable Price.

Clausing's line of Heavy Duty EVS Mills are easy to operate, require less maintenance than mechanical variable speed machines and offer features found only on higher priced EVS Mills...

- Quick and accurate rpm setting
- Convenient, head mounted, easy to use control panel
- LCD spindle speed display
- Up to 4 hp spindle motor standard
- Spindle brake with auto power off
- Totally enclosed electric's with Yaskawa A.C. inverter variable speed drive
- Carbon steel, hardened and ground, chrome plated quill
- Coolant system
- Up to 11" x 58" table size
- Meehanite castings for superior rigidity
- Hardened and ground table with 3 ground T-slots
- Double nuts for easy backlash adjustment
- Up to 38.2" X axis travel, 16" Y axis travel, 17.7" knee travel and 5" quill travel
- All ways are hardened and ground with Turcite B coating on X and Y axis ways for wear resistance and smooth operation



Standard Features...

- Meehanite castings for superior rigidity and wear resistance
- Hardened and ground ways
- Ground ram ways
- Column & knee way covers
- Hardened and ground table surface
- Ground T-slots to provide reference edge for positioning workpiece
- Hardened and ground spindle
- Hardened, ground and chromed quill
- Hardened X & Y axis leadscrew and Nickel Phosphorous treated
- Coolant system
- Flexible segmented coolant nozzle
- 3 hp AC motor on 400EVS & 450EVS, optional 4hp AC motor for 450EVS
- 4 hp AC motor on 500EVS
- Yaskawa inverter variable speed drive
- Dovetail X,Y & Z axis ways on 400EVS
- Square Y axis ways and dovetail X & Z axis ways on 450EVS
- Square Y & Z axis ways and dovetail X axis ways on 500EVS
- Lever operated manual rapid quill movement
- Handwheel for fine quill feed
- Adjustable automatic feed disengagement for quill feed in both directions
- Micrometer depth stop
- Reversing switch for clockwise or counter clockwise operation
- R-8 or ISO 30 spindle
- Spindle hand brake with auto power off
- One-shot lubrication
- Test and accuracy chart
- Tools, tool box, operation and parts manuals

SPECIFICATIONS	400EVS	450EVS	500EVS
TABLE			
Table Size	10" x 50" (254 x 1270mm)	10" x 54" (254 x 1372mm)	11" x 58" (254 x 11473mm)
No. of T-slots	3	3	3
T-slot width	.63" (16mm)	.63" (16mm)	.63" (16mm)
T-slot center distance	2.48" (63mm)	2.48" (63mm)	2.48" (63mm)
TRAVELS			
X axis, longitudinal	35" (889mm)	34.6" (879mm)	38.2" (970mm)
Y axis, cross	16" (406mm)	16" (406mm)	16" (406mm)
Z axis, knee	16" (406mm)	16" (406mm)	17.7" (450mm)
Ram travel	22" (559mm)	22" (559mm)	22" (559mm)
Ram swivel	360°	360°	360°
Spindle to column	5.9"-28.9" (150 - 734mm)	5.8"-28.9" (147 - 734mm)	5.3"-27.2" (135 - 691mm)
Spindle nose to table	3.54"-19.7" (90 - 500mm)	3.54"-19.7" (90 - 500mm)	1.57"-19.2" (40 - 489mm)
SPINDLE HEAD			
Spindle drive motor	3 hp (2.25 kw)	3 hp (2.25 kw)	4 hp (3 kw)
Spindle speed range	50-5000 rpm	50-5000 rpm	50-5000 rpm
Spindle taper	R-8 or ISO 30	R-8 or ISO 30	R-8 or ISO 30
Quill travel	5" (127mm)	5" (127mm)	5" (127mm)
Quill diameter	3.28" (83mm)	3.38" (83mm)	3.38" (83mm)
Quill feed (in/rev) (mm/rev)	.00157"/.00315"/.006" (.004"/.08"/.152)		
Head tilt (front or back)	45°	45°	45°
Head tilt (left or right)	90°	90°	90°
DIMENSIONS AND WEIGHT			
Column turret diameter	15.75" (400mm)	15.75" (400mm)	16.54" (420mm)
Knee width	13.75" (349mm)	15.35" (390mm)	15.35" (390mm)
Knee bearing length	17.72" (450mm)	17.72" (450mm)	19.69" (500mm)
Saddle length	20.08" (510mm)	25.59" (650mm)	25.59" (650mm)
Table bearing length	11.26" (286mm)	11.26" (286mm)	11.02" (280mm)
Ram/turret bearing length	17.72" (450mm)	17.72" (450mm)	17.72" (450mm)
Machine weight	2,640 lbs. (1198 kg)	2,750 lbs. (1247 kg)	3,300 lbs. (1497 kg)
Shipping weight	3,040 lbs. (1379 kg)	3,150 lbs. (1429 kg)	3,700 lbs. (1678 kg)

Specifications and design subject to change without notice.

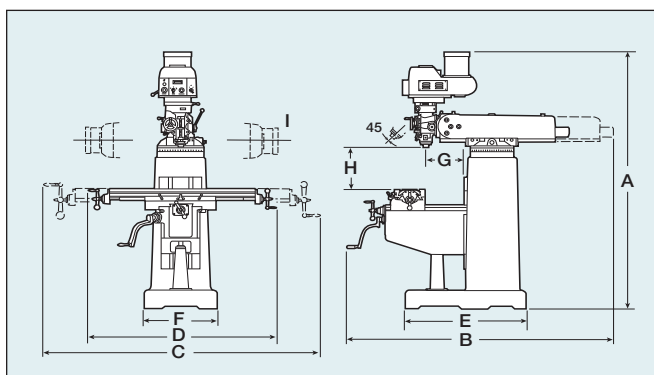

MODEL	400EVS	450EVS	500EVS
A Height	88.6"(2250mm)	88.6"(2250mm)	90.6"(2300mm)
B Depth w/ram travel	78"(1980mm)	78"(1980mm)	82.7"(2100mm)
C Width w/table travel	102"(2590mm)	105"(2667mm)	110"(2795mm)
D Width	66"(1676mm)	70"(1778mm)	74"(1880mm)
E Base depth	39"(990mm)	39"(990mm)	44"(1118mm)
F Base width	23.6"(600mm)	23.6"(600mm)	25"(635mm)
G Spindle to column	5.9"-28.9"(150-735mm)	5.9"-28.9"(150-735mm)	5.3"-27.2"(135-690mm)
H Spindle to table	3.54"-19.7"(90-500mm)	3.54"-19.7"(90-500mm)	1.57"-19.2"(40-488mm)
I Head tilt	90° right or left		